



PICO-RAP4

PICO-ITX Single Board Computer

User's Manual 5th Ed

Copyright Notice

This document is copyrighted, 2026. All rights are reserved. The original manufacturer reserves the right to make improvements to the products described in this manual at any time without notice.

No part of this manual may be reproduced, copied, translated, or transmitted in any form or by any means without the prior written permission of the original manufacturer. Information provided in this manual is intended to be accurate and reliable. However, the original manufacturer assumes no responsibility for its use, or for any infringements upon the rights of third parties that may result from its use.

The material in this document is for product information only and is subject to change without notice. While reasonable efforts have been made in the preparation of this document to assure its accuracy, AAEMON assumes no liabilities resulting from errors or omissions in this document, or from the use of the information contained herein.

AAEMON reserves the right to make changes in the product design without notice to its users.

Acknowledgement

All other products' name or trademarks are properties of their respective owners.

- Microsoft Windows® is a registered trademark of Microsoft Corp.
- Intel® is a registered trademark of Intel Corporation
- Intel® Core™ is a trademark of Intel Corporation
- ITE is a trademark of Integrated Technology Express, Inc.
- IBM, PC/AT, PS/2, and VGA are trademarks of International Business Machines Corporation.
- Ubuntu and Canonical are registered trademarks of Canonical Ltd.
- Linux® is the registered trademark of Linus Torvalds in the U.S. and other countries.
- Realtek is a trademark of Realtek Semiconductor Corporation

All other product names or trademarks are properties of their respective owners.

Omission of a product name from this list does not imply any claim to ownership by the publisher of this document.

Packing List

Before setting up your product, please make sure the following items have been shipped:

Item	Quantity
● PICO-RAP4	1

If any of these items are missing or damaged, please contact your distributor or sales representative immediately.

About this Document

This User's Manual contains all the essential information, such as detailed descriptions and explanations on the product's hardware and software features (if any), its specifications, dimensions, jumper/connector settings/definitions, and driver installation instructions (if any), to facilitate users in setting up their product.

Users may refer to the product page on AAEON.com for the latest version of this document.

Safety Precautions

Please read the following safety instructions carefully. It is advised that you keep this manual for future references

1. All cautions and warnings on the device should be noted.
2. Make sure the power source matches the power rating of the device.
3. Position the power cord so that people cannot step on it. Do not place anything over the power cord.
4. Always completely disconnect the power before working on the system's hardware.
5. No connections should be made when the system is powered as a sudden rush of power may damage sensitive electronic components.
6. If the device is not to be used for a long time, disconnect it from the power supply to avoid damage by transient over-voltage.
7. Always disconnect this device from any AC supply before cleaning.
8. While cleaning, use a damp cloth instead of liquid or spray detergents.
9. Make sure the device is installed near a power outlet and is easily accessible.
10. Keep this device away from humidity.
11. Place the device on a solid surface during installation to prevent falls
12. Do not cover the openings on the device to ensure optimal heat dissipation.
13. Watch out for high temperatures when the system is running.
14. Do not touch the heat sink or heat spreader when the system is running
15. Never pour any liquid into the openings. This could cause fire or electric shock.
16. As most electronic components are sensitive to static electrical charge, be sure to ground yourself to prevent static charge when installing the internal components. Use a grounding wrist strap and contain all electronic components in any static-shielded containers.

17. If any of the following situations arises, please contact our service personnel:
 - i. Damaged power cord or plug
 - ii. Liquid intrusion to the device
 - iii. Exposure to moisture
 - iv. Device is not working as expected or in a manner as described in this manual
 - v. The device is dropped or damaged
 - vi. Any obvious signs of damage displayed on the device

18. **DO NOT LEAVE THIS DEVICE IN AN UNCONTROLLED ENVIRONMENT WHERE THE STORAGE TEMPERATURE IS BELOW -20° C (-4°F) OR ABOVE 60°C (140°F) TO PREVENT DAMAGE.**

Warning!



This device complies with Part 15 FCC Rules. Operation is subject to the following two conditions: (1) this device may not cause harmful interference, and (2) this device must accept any interference received including interference that may cause undesired operation.

Caution:

There is a danger of explosion if the battery is incorrectly replaced. Replace only with the same or equivalent type recommended by the manufacturer. Dispose of used batteries according to the manufacturer's instructions and your local government's recycling or disposal directives.

Attention:

Il y a un risque d'explosion si la batterie est remplacée de façon incorrecte. Ne la remplacer qu'avec le même modèle ou équivalent recommandé par le constructeur. Recycler les batteries usées en accord avec les instructions du fabricant et les directives gouvernementales de recyclage.

产品中有毒有害物质或元素名称及含量

AAEON 主板/子板/背板

QO4-381 Rev.A2

部件名称	有毒有害物质或元素					
	铅 (Pb)	汞 (Hg)	镉 (Cd)	六价铬 (Cr(VI))	多溴联苯 (PBB)	多溴二苯醚 (PBDE)
印刷电路板 及其电子组件	×	○	○	○	○	○
外部信号 连接器及线材	×	○	○	○	○	○

本表格依据 SJ/T 11364 的规定编制。

○：表示该有毒有害物质在该部件所有均质材料中的含量均在GB/T 26572标准规定的限量要求以下。

×：表示该有害物质的某一均质材料超出了GB/T 26572的限量要求，然而该部件仍符合欧盟指令2011/65/EU 的规范。

环保使用期限(EFUP (Environmental Friendly Use Period)) : 10年

备注：此产品所标示之环保使用期限，系指在一般正常使用状况下。

China RoHS Requirement (EN)

Name and content of hazardous substances in product

AAEON Main Board/ Daughter Board/ Backplane

QO4-381 Rev.A2

Part Name	Hazardous Substances					
	铅 (Pb)	汞 (Hg)	镉 (Cd)	六价铬 (Cr(VI))	多溴联苯 (PBB)	多溴二苯醚 (PBDE)
PCB Assemblies	×	○	○	○	○	○
Connector and Cable	×	○	○	○	○	○

The table is prepared in accordance with the provisions of SJ/T 11364.

○: Indicates that said hazardous substance contained in all of the homogenous materials for this product is below the limit requirement of GB/T 26572.

×: Indicates that said hazardous substance contained in at least one of the homogenous materials used for this part is above the limit requirement of GB/T 26572. But this product still be compliance with 2011/65/EU Directive. (allowed with 2011/65/EU Annex III of RoHS exemption with number 6(c),7(a),7(c)-1).

EFUP (Environment Friendly Use Period) value: 10 years

Notes: This product defined period of use is under normal condition.

Table of Contents

Chapter 1 - Product Specifications	1
1.1 Specifications.....	2
1.2 Function Block Diagram.....	5
Chapter 2 – Hardware Information	6
2.1 Dimensions.....	7
2.2 Jumpers and Connectors	8
2.3 List of Jumpers.....	10
2.3.1 Clear CMOS Jumper & Auto Power Button Enable/Disable (JP5)	10
2.4 List of Connectors	11
2.4.1 +5V Output for SATA HDD (CN1)	12
2.4.2 SATA Port (CN2).....	12
2.4.3 DC Jack Power Input [Reserved] (CN3)	13
2.4.4 Front Panel (CN4).....	13
2.4.5 Mini Card Slot (CN6).....	14
2.4.6 LVDS Inverter/Backlight Connector (CN7)	16
2.4.7 IMVP9 FW Reflash (CN8)	17
2.4.8 Audio In/Out (CN9)	17
2.4.9 DDR5 SODIMM (CN10)	18
2.4.10 4-Pin Fan Connector (CN11).....	19
2.4.11 61-Pin MIPI CSI-2 Connector (CN13).....	19
2.4.12 GPIO (CN14)	20
2.4.13 COM Port 1 (CN15).....	21
2.4.14 SPI Flash Programming Port (CN16).....	22
2.4.15 LVDS/eDP Connector (CN17).....	23
2.4.16 COM Port 2 (CN18).....	24

2.4.17	M.2 2280 M-Key (CN19).....	26
2.4.18	Dual RJ-45 LAN Port (CN20)	28
2.4.19	HDMI Port (CN21).....	29
2.4.20	Port 80 Debug Port/SMBus/I2C (CN22).....	30
2.4.21	RTC Battery Connector (CN24).....	31
2.4.22	Dual USB 3.2 Port (CN30).....	31
2.4.23	Terminal Block DC Input Connector (CN36).....	32
2.4.24	USB 2.0 Port 1/Port 2 (CN38).....	33
2.5	Thermal Assembly Options.....	34
2.5.1	Fan Assembly	34
2.5.2	Heatspreader Assembly	35
Chapter 3 - AMI BIOS Setup		36
3.1	System Test and Initialization	37
3.2	AMI BIOS Setup.....	38
3.3	Setup Submenu: Main.....	39
3.4	Setup Submenu: Advanced	40
3.4.1	CPU Configuration	41
3.4.2	PCH-FW Configuration	42
3.4.3	Firmware Update Configuration.....	43
3.4.4	PTT Configuration	44
3.4.5	Trusted Computing	45
3.4.6	SATA Configuration	47
3.4.7	NVMe Configuration	48
3.4.8	Hardware Monitor	49
3.4.8.1	Smart Fan Mode Configuration.....	50
3.4.9	SIO Configuration	51
3.4.9.1	Serial Port 1 Configuration.....	52

3.4.9.2	Serial Port 2 Configuration	53
3.4.10	Serial Port Console Redirection	54
3.4.11	Legacy Console Redirection Settings	55
3.4.12	GPIO Port Configuration.....	56
3.4.13	Power Management	57
3.4.14	AAEON Smart Boost	58
3.4.15	AAEON BIOS Robot.....	59
3.5	Setup Submenu: Chipset.....	61
3.5.1	System Agent (SA) Configuration	62
3.5.2	Memory Configuration	63
3.5.3	LVDS Panel Configuration.....	64
3.5.4	PCH-IO Configuration.....	67
3.6	Setup Submenu: Security	68
3.6.1	Secure Boot	69
3.6.2	Key Management.....	70
3.7	Setup Submenu: Boot.....	72
3.7.1	BBS Priorities.....	73
3.8	Setup Submenu: Save & Exit	74
3.9	Setup Submenu: Firmware Update	75
3.10	Setup Submenu: MEBx.....	76
3.10.1	Intel® AMT Configuration	77
3.10.2	Redirection features	78
3.10.3	User Consent.....	79
3.10.4	Power Control	80
Chapter 4	– Driver Installation	81
4.1	Driver Download/Installation	82
Appendix A	– Mating Connectors	84
A.1	List of Mating Connectors and Cables	85

Appendix B - I/O Information 86

- B.1 I/O Address Map..... 87
- B.2 IRQ Mapping Chart..... 89
- B.3 Large Memory Map..... 91
- B.4 Memory Address Map..... 92

Chapter 1

Product Specifications

1.1 Specifications

System

Form Factor	Pico-ITX
CPU	13th Generation Intel® Core™/U-series Processors: Intel® Core™ i7-1360P (4P+8E/16T, 2.20 GHz, 28W) Intel® Core™ i7-1370PE (6P+8E/20T, 1.90 GHz, 28W) Intel® Core™ i7-1370PRE (6P+8E/20T, 1.90 GHz, 28W) Intel® Core™ i5-1340PE (4P+8E/16T, 1.80 GHz, 28W) Intel® Core™ i3-1320PE (4P+4E/12T, 1.70 GHz, 28W) Intel® Processor U300E (1P+4E/6T, 1.10 GHz, 15W)
Chipset	Integrated with Intel® SoC
Memory Type	DDR5 5200, SODIMM x 1, Non-ECC (Max. 32GB)
BIOS	UEFI
Wake on LAN	Yes
Watchdog Timer	255 Levels
Security	TPM 2.0
RTC Battery	Lithium Battery 3V/240mAh
Dimension	3.94" x 2.84" (100mm x 72mm)
Gross Weight	0.18 lb. (0.08Kg)
OS Support	Windows® 10/11 (64-bit) Ubuntu 22.04.2 (eDP is verified on Ubuntu 23.10.1)

Power

Power Requirement	12V only
Power Supply Type	AT/ATX
Connector	2-pin Phoenix Connector (Default) Lockable DC Jack Connector (Optional)

Power

Power Consumption	Intel® Core™ i7-1370PE, DDR5 32GB, 4.51A @+12V (Typical) Intel® Core™ i7-1370PE, DDR5 32GB, 7.46A @+12V (Max)
--------------------------	--

Display

Controller	Intel® UHD Graphics
LVDS/eDP	LVDS x 1 (18/24-bit 2CH), 1920 x 1200 @60Hz eDP 1.4 x 1, up to 3840 x 2160 (Optional)
Display Interface	HDMI 1.4 x 1, 3840 x 2160 @30Hz
Multiple Display	Up to 2 Simultaneous Displays

Audio

Codec	Realtek ALC256
Audio Interface	Line-in/Line-out/Mic (Optional, Audio function not available for WiTAS SKU)
Speaker	—

External I/O

Ethernet	Intel® Ethernet Controller I226, 2.5GbE RJ-45 x 1 Intel® Ethernet Connection I219, 1GbE RJ-45 x 1
USB	USB 3.2 Gen 2 x 2
Serial Port	—
Video	HDMI 1.4 x 1

Internal I/O

USB	USB 2.0 x 2
Serial Port	COM 1~2 (RS-232/422/485, supports 5V/12V/RI)
Video	LVDS/eDP x 1 (Default: LVDS) Inverter x 1 (12V/2A)

Internal I/O

SATA	SATA 6Gb/s x 1 +5V SATA Power Connector x 1
Audio	Audio Header (Optional, Audio function not available for WiTAS SKU)
DIO/GPIO	GPIO 8-bit
SMBus/I2C	SMBus/I2C x 1 (Default: SMBus)
Touch	—
Fan	4-pin Smart Fan x 1
SIM	—
Front Panel	HDD LED, PWR LED, Power Button, Buzzer, Reset
Others	—

Expansion

Mini PCI-E/mSATA	Half-size mSATA/mPCIe x 1 (default: mSATA, select with BIOS)
M.2	M.2 2280 M-Key x 1 (PCIe 4.0 [x4])
Others	MIPI-CSI via 61-Pin FPC Connector

Environmental

Operating Temperature	32°F – 140°F (0°C – 60°C) WiTAS 2: -40°F – 185°F (-40°C – 85°C)
Storage Temperature	-40°F – 185°F (-40°C – 85°C)
Operating Humidity	0% – 90% relative humidity, non-condensing
MTBF (Hours)	1,087,053
EMC	CE/FCC Class A

1.2 Function Block Diagram

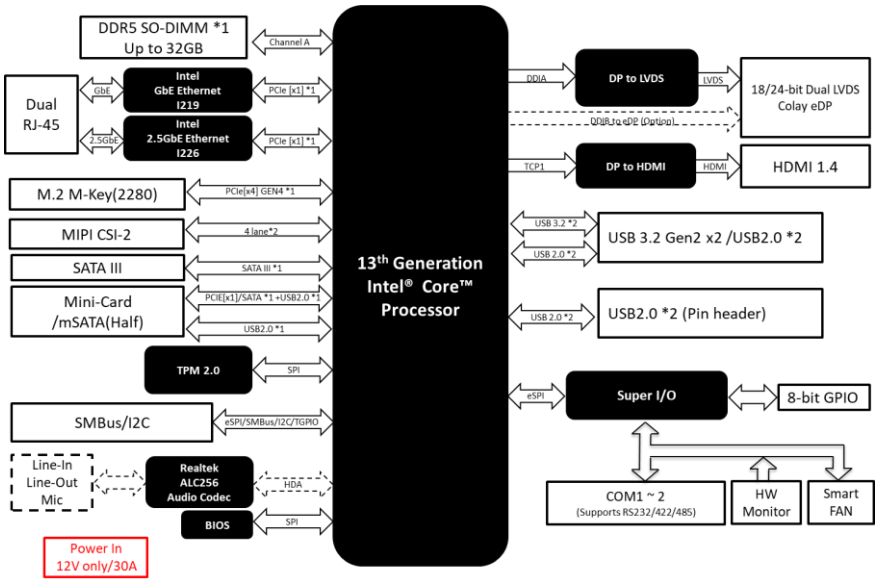

PICO-ITX Board

PICO-RAP4

Chapter 2

Hardware Information

2.1 Dimensions

Top View

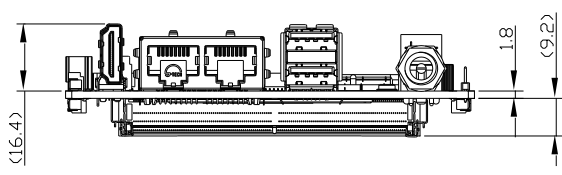
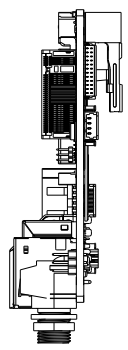
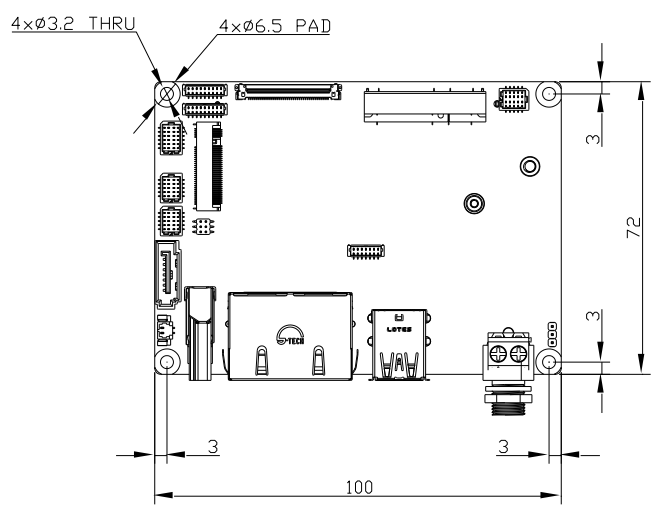

Bottom View

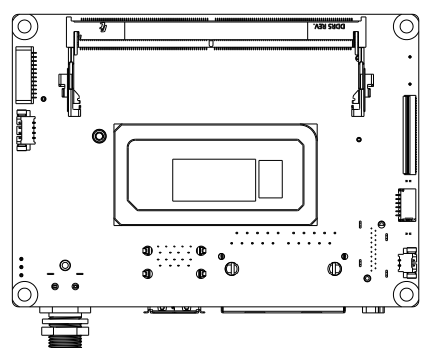

2.2 Jumpers and Connectors

Top View

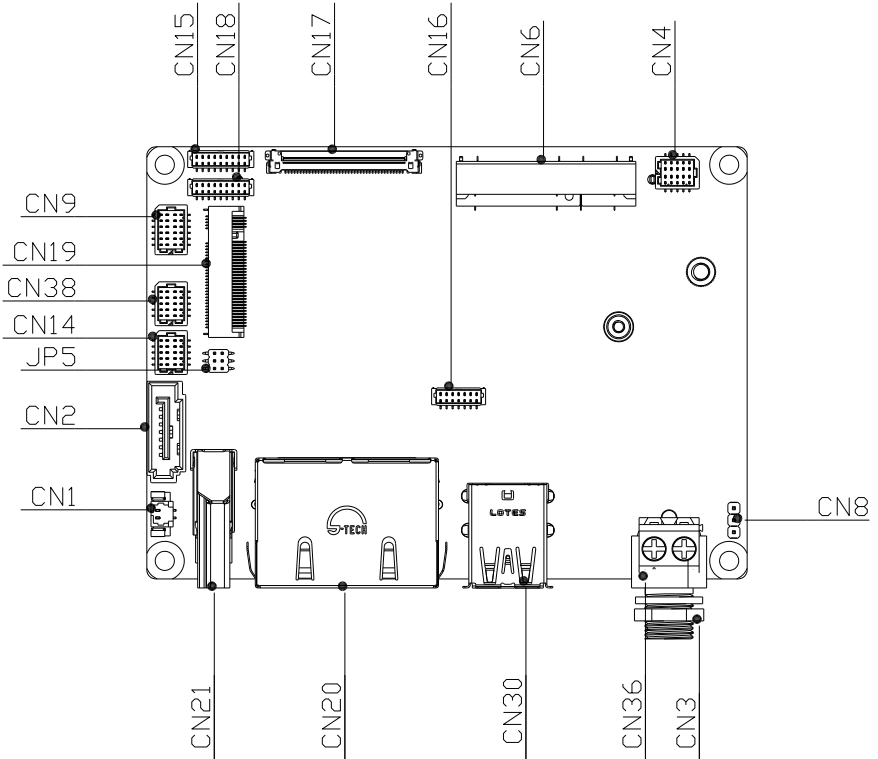

Bottom View

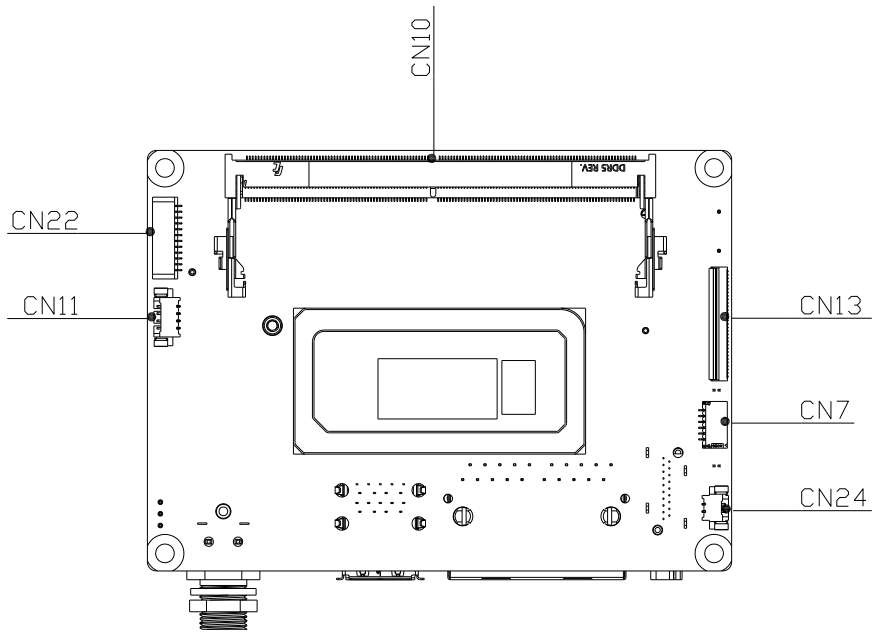

2.3 List of Jumpers

Jumpers allow users to manually customize system configurations to their suitable application needs.

Please refer to the table below for all of the board's jumpers that you can configure for your application

Label	Function
JP5	Clear CMOS Jumper & Auto Power Button Enable/Disable

2.3.1 Clear CMOS Jumper & Auto Power Button Enable/Disable (JP5)

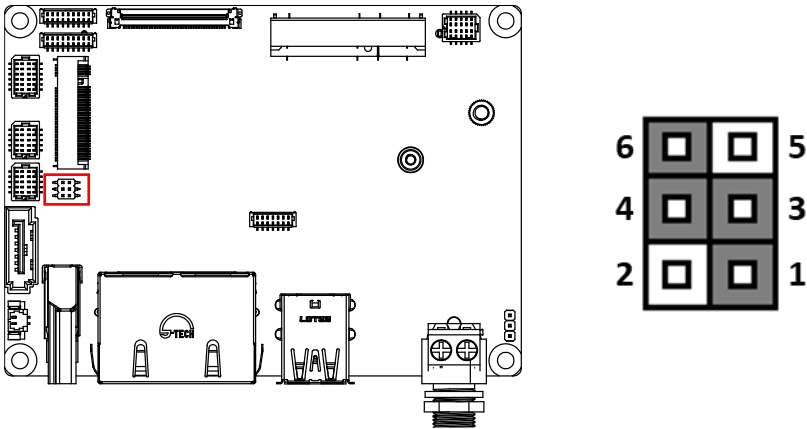

Clear CMOS Jumper	
Pin	Function
1-3	Save CMOS (Default)
3-5	Clear CMOS
Auto Power Button Enable/Disable	
Pin	Function
2-4	Disable
4-6	Enable (Default)

2.4 List of Connectors

Please refer to the table below for all of the board's connectors that you can configure for your application

Label	Function
CN1	+5V Output for SATA HDD
CN2	SATA Port
CN3	DC Jack Power Input [Reserved]
CN4	Front Panel
CN6	Mini Card Slot
CN7	LVDS Inverter/Backlight Connector
CN8	IMVP9 FW Reflash
CN9	Audio In/Out
CN10	DDR5 SODIMM
CN11	4-Pin Fan Connector
CN13	61-Pin MIPI CSI-2 Connector
CN14	GPIO
CN15	COM Port 1
CN16	SPI Flash Programming Port
CN17	LVDS/eDP Connector
CN18	COM Port 2
CN19	M.2 2280 M-Key
CN20	Dual RJ-45 LAN Port
CN21	HDMI Port
CN22	Port 80 Debug Port/SMBus/I2C
CN24	RTC Battery Connector
CN30	Dual USB 3.2 Port
CN36	Terminal Block DC Input Connector
CN38	USB 2.0 Port 1/Port 2

2.4.1 +5V Output for SATA HDD (CN1)

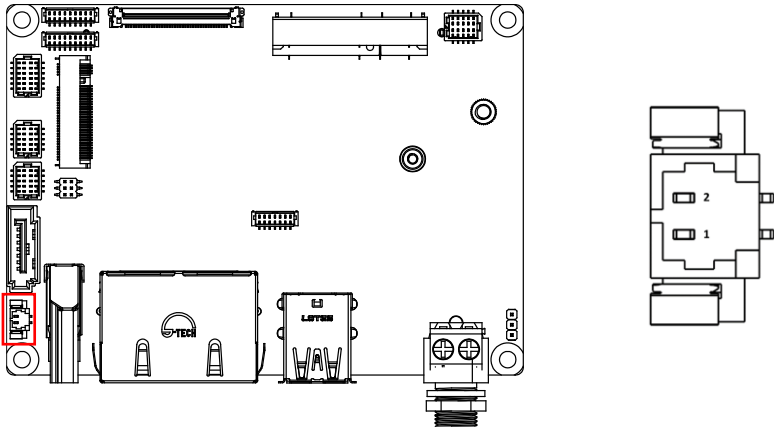

Pin	Pin Name	Signal Type	Signal Level
1	+V5S	PWR	+5V
2	GND	GND	GND

Note: The driving current of +V5S supports up to 1A.

2.4.2 SATA Port (CN2)

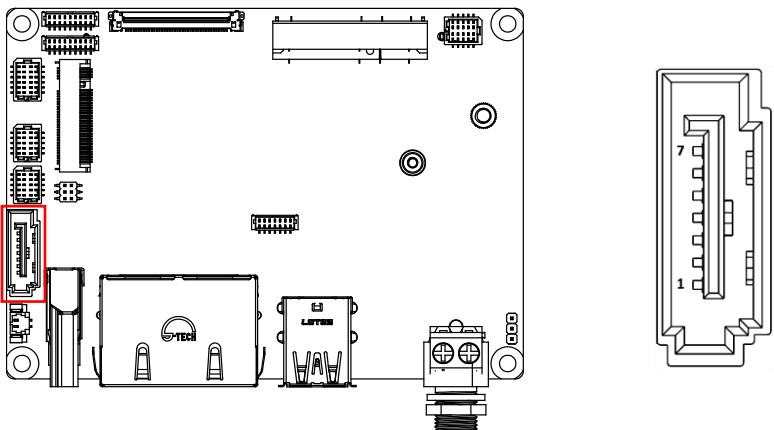

Pin	Pin Name	Signal Type	Signal Level
1	GND	GND	GND
2	SATA_TXP	DIFF	-
3	SATA_TXN	DIFF	-

Pin	Pin Name	Signal Type	Signal Level
4	GND	GND	GND
5	SATA_RXN	DIFF	-
6	SATA_RXP	DIFF	-
7	GND	GND	GND

2.4.3 DC Jack Power Input [Reserved] (CN3)

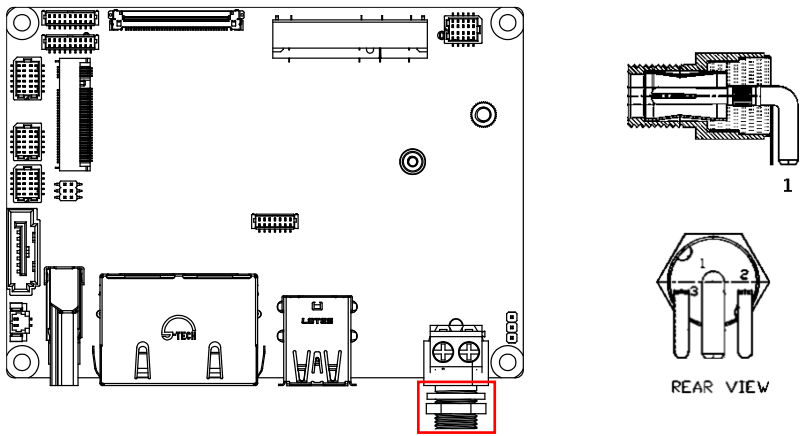

Pin	Pin Name	Signal Type	Signal Level
1	+V_IN	PWR	+12V
2	GND	GND	GND
3	GND	GND	GND

2.4.4 Front Panel (CN4)

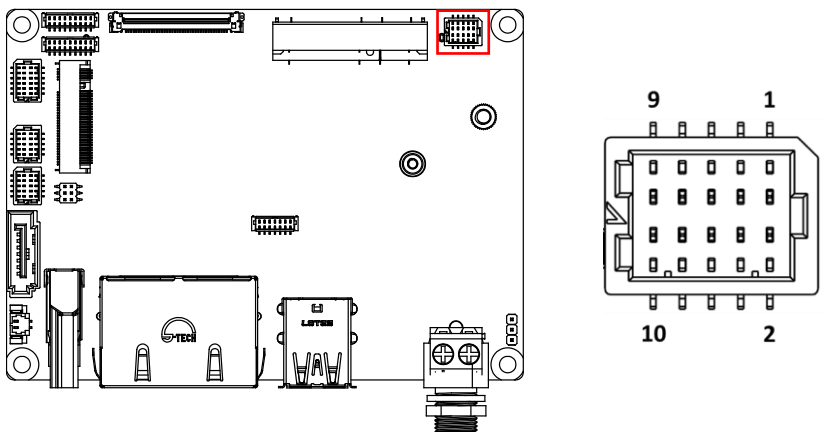

Pin	Pin Name	Signal Type	Signal Level
1	GND	GND	GND
2	EXT_PWRBTN#	IN	-
3	SATA_LED-	OUT	-
4	SATA_LED+	OUT	-
5	BUZZER-	OUT	-
6	BUZZER+	OUT	-
7	GND	GND	GND
8	PWR_LED+	OUT	-
9	GND	GND	GND
10	HWRST#	IN	-

2.4.5 Mini Card Slot (CN6)

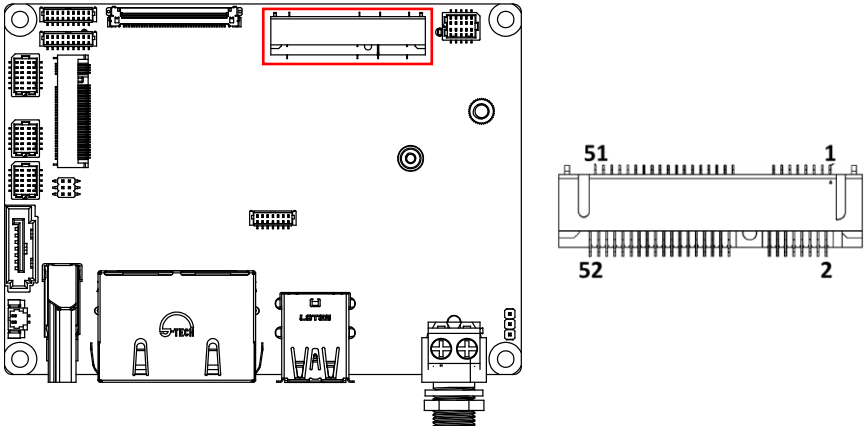

Pin	Pin Name	Signal Type	Signal Level
1	PCIE_WAKE#	IN	-
2	+3.3V	PWR	+3.3V
3	NC	NC	NC
4	GND	GND	GND
5	NC	NC	NC
6	+1.5V	PWR	+1.5V
7	PCIE_CLK_REQ#	IN	-
8	NC	NC	NC
9	GND	GND	GND
10	NC	NC	NC
11	PCIE_REF_CLK-	DIFF	-
12	NC	NC	NC

Pin	Pin Name	Signal Type	Signal Level
13	PCIE_REF_CLK+	DIFF	-
14	NC	NC	NC
15	GND	GND	GND
16	NC	NC	NC
17	NC	NC	NC
18	GND	GND	GND
19	NC	NC	NC
20	W_DISABLE#	OUT	+3.3V
21	GND	GND	GND
22	PCIE_RST3	OUT	+3.3V
23	PCIE_RX-/SATA_RX-	DIFF	GND
24	+3.3V	PWR	+3.3V
25	PCIE_RX+/SATA_RX+	DIFF	-
26	GND	GND	GND
27	GND	GND	GND
28	+1.5V	PWR	+1.5V
29	GND	GND	GND
30	SMB_CLK	IN/OUT	+3.3V
31	PCIE_TX-/SATA_TX-	DIFF	-
32	SMB_DATA	IN/OUT	+3.3V
33	PCIE_TX+/SATA_TX+	DIFF	-
34	GND	GND	GND
35	GND	GND	GND
36	USB_D-	DIFF	-
37	GND	GND	GND
38	USB_D+	DIFF	-
39	+3.3V	PWR	+3.3V
40	GND	GND	GND
41	+3.3V	PWR	+3.3V
42	NC	NC	NC
43	GND	GND	GND
44	NC	NC	NC
45	NC	NC	NC
46	NC	NC	NC
47	NC	NC	NC
48	+1.5V	PWR	+1.5V
49	NC	NC	NC
50	GND	GND	GND
51	NC	NC	NC

Pin	Pin Name	Signal Type	Signal Level
52	+3.3V	PWR	+3.3V

Note: This is a co-lay design from PICO-V2K4, check pin define before use.

Note: Mini-Card/mSATA function can be set by BIOS. Default is mSATA.

2.4.6 LVDS Inverter/Backlight Connector (CN7)

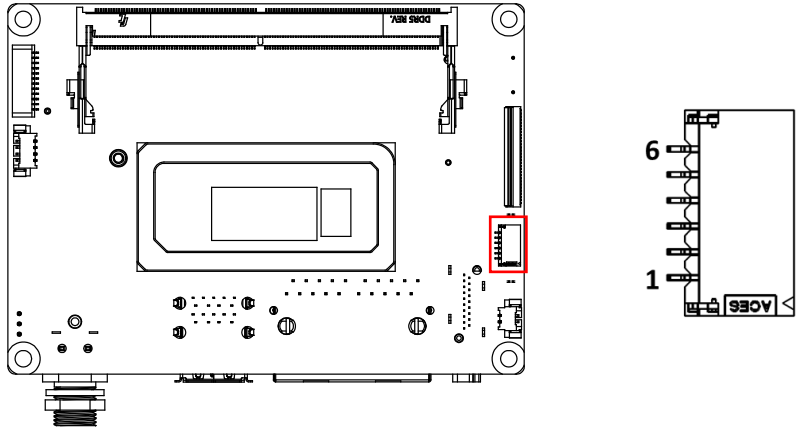

Pin	Pin Name	Signal Type	Signal Level
1	BKL_PWR	PWR	+5V/+12V(Default)
2	BKL_PWR	PWR	+5V/+12V(Default)
3	BKL_CONTROL	OUT	-
4	GND	GND	GND
5	GND	GND	GND
6	BKL_ENABLE	OUT	+3.3V

Note: LVDS/BKL_PWR can be set to +12V or +5V by BOM.

Populate R107 with a 0-ohm resistor and remove R93 to enable 5V [Default: 12V].

Note: The driving current of BKL_PWR supports up to 2A..

2.4.7 IMVP9 FW Reflash (CN8)

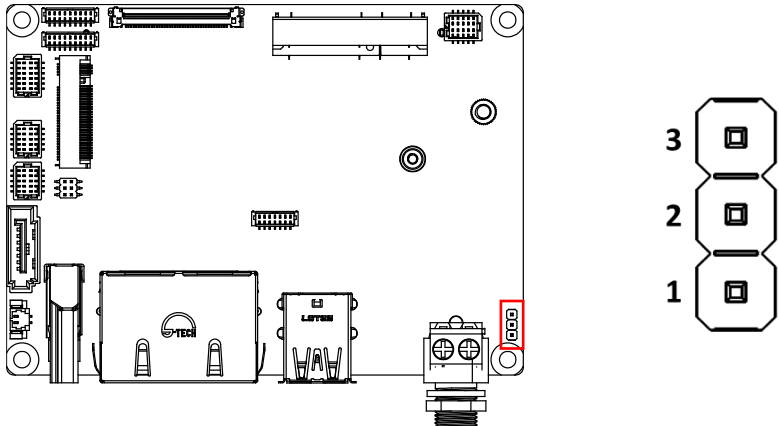

Pin	Pin Name	Signal Type	Signal Level
1	PM_SCL	I/O	+3.3V
2	PM_DAT	OUT	+3.3V
3	GND	GND	

2.4.8 Audio In/Out (CN9)

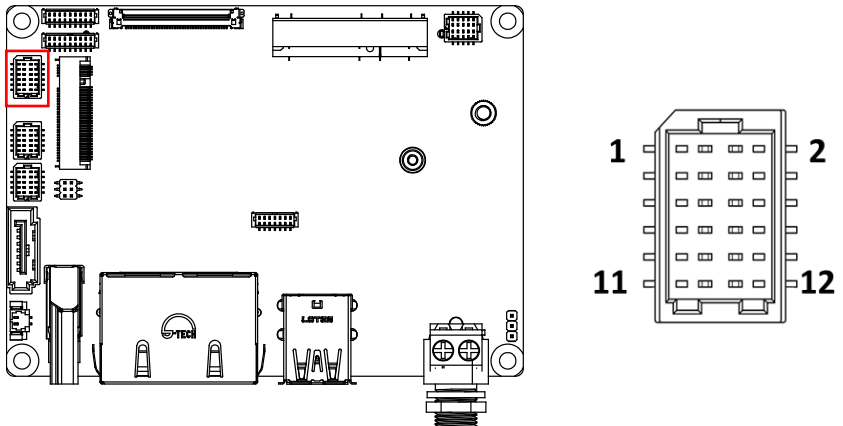

Pin	Pin Name	Signal Type	Signal Level
1	RIGHT_OUT	OUT	-
2	MIC_R	IN	-
3	LEFT_OUT	OUT	-
4	MIC_L	IN	-

Pin	Pin Name	Signal Type	Signal Level
5	JD_LOUT	IN	-
6	JD_MIC	IN	-
7	GND_AUDIO	GND	GND
8	GND_AUDIO	GND	GND
9	JD_LIN	IN	-
10	LINE_R_IN	IN	-
11	+VDD_AUDIO	PWR	+5V
12	LINE_L_IN	IN	-

2.4.9 DDR5 SODIMM (CN10)

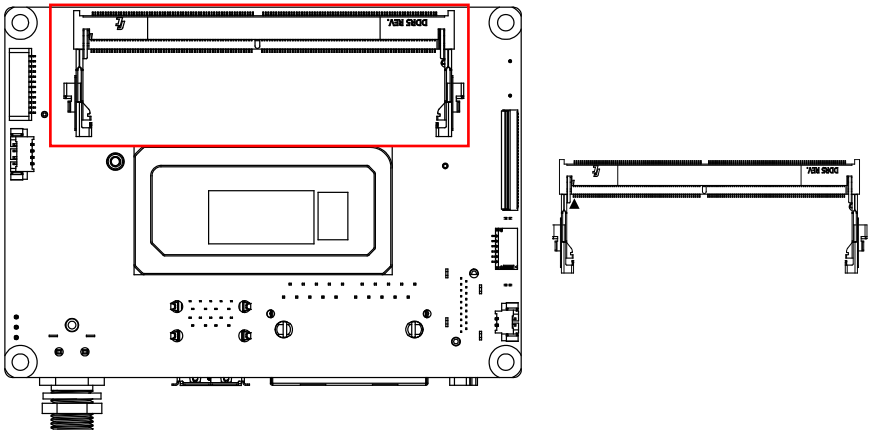

Standard specification.

2.4.10 4-Pin Fan Connector (CN11)

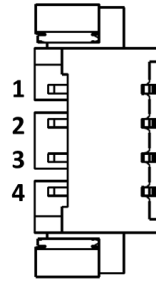
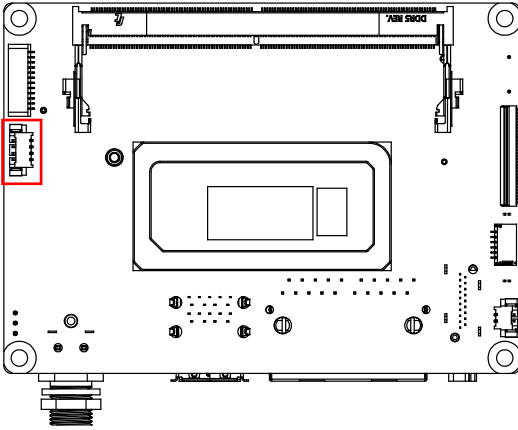

Pin	Pin Name	Signal Type	Signal Level
1	GND	GND	GND
2	FAN_POWER	PWR	+12V
3	FAN_TAC	IN	-
4	FAN_CTL	OUT	-

Note: The driving current of FAN_POWER supports up to 1A.

2.4.11 61-Pin MIPI CSI-2 Connector (CN13)

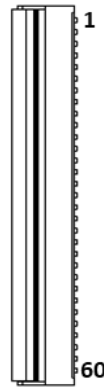
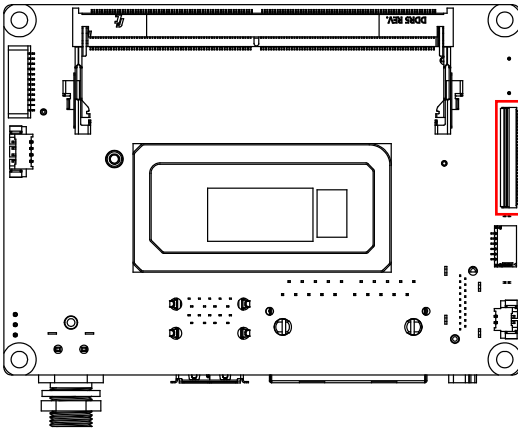

Standard specification.

2.4.12 GPIO (CN14)

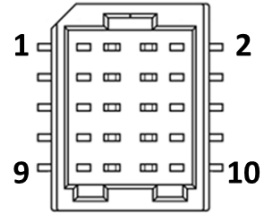
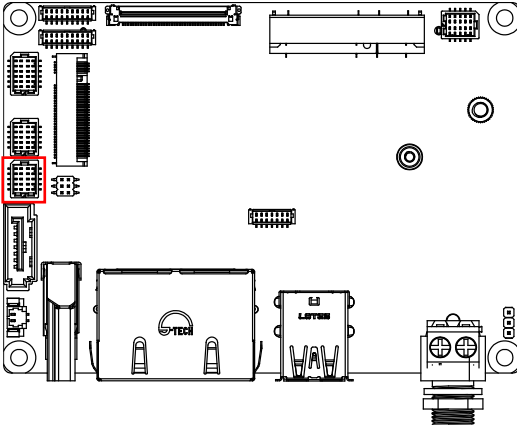

Pin	Pin Name	Signal Type	Signal Level
1	GPIO_0	IN/OUT	-
2	GPIO_1	IN/OUT	-
3	GPIO_2	IN/OUT	-
4	GPIO_3	IN/OUT	-
5	GPIO_4	IN/OUT	-
6	GPIO_5	IN/OUT	-
7	GPIO_6	IN/OUT	-
8	GPIO_7	IN/OUT	-
9	+V5S	PWR	+5V
10	GND	GND	GND

Note: The driving current of +V5S supports up to 0.5A.

2.4.13 COM Port 1 (CN15)

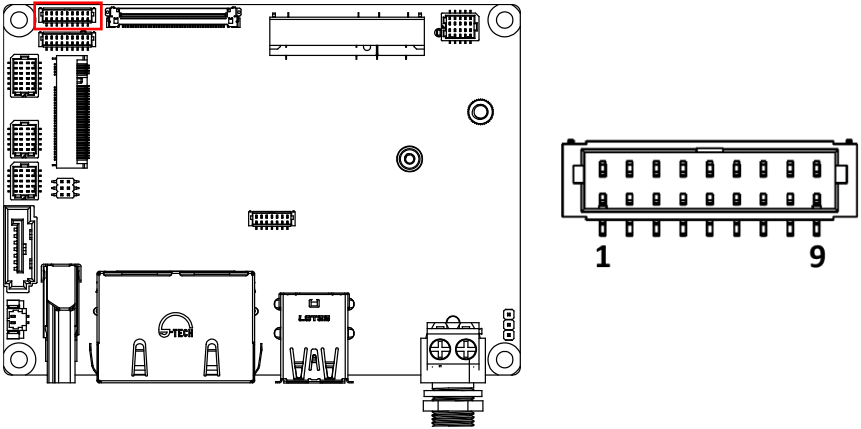

COM Port 1 RS-232 (Default)

Pin	Pin Name	Signal Type	Signal Level
1	DCD1	IN	-
2	DSR1	IN	-
3	RX1	IN	-
4	RTS1	OUT	±9V
5	TX1	OUT	±9V
6	CTS1	IN	-
7	DTR1	OUT	±9V
8	RI1/ +5V/ +12V	IN/ PWR	+5V/+12V
9	GND	GND	GND

COM Port 1 RS-422

Pin	Pin Name	Signal Type	Signal Level
1	RS422_TX-	OUT	±9V
2	NC	-	-
3	RS422_TX+	OUT	±9V
4	NC	-	-
5	RS422_RX+	IN	-
6	NC	-	-
7	RS422_RX-	IN	-
8	NC	-	-
9	GND	GND	GND

COM Port 1 RS-485			
Pin	Pin Name	Signal Type	Signal Level
1	RS485_D-	IN/OUT	±9V
2	NC	-	-
3	RS485_D+	IN/OUT	±9V
4	NC	-	-
5	NC	-	-
6	NC	-	-
7	NC	-	-
8	NC	-	-
9	GND	GND	GND

Note: COM 1 RS-232/422/485 can be set by BIOS setting. Default is RS-232.

Note: Pin 8 function can be set by BOM.

2.4.14 SPI Flash Programming Port (CN16)

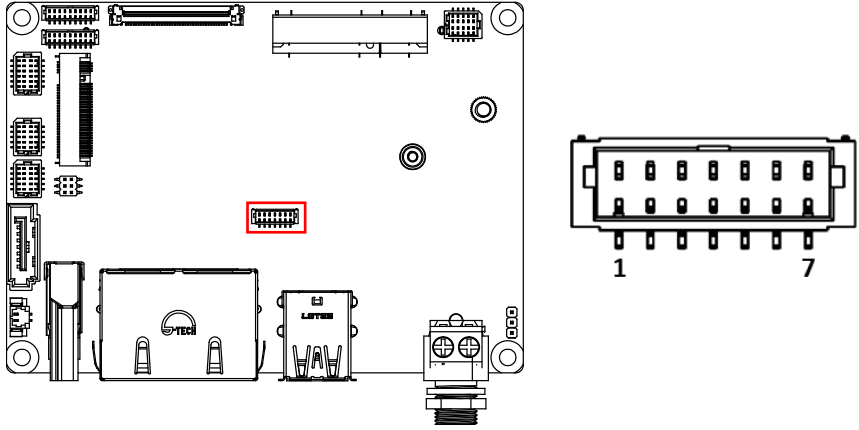

Pin	Pin Name	Signal Type	Signal Level
1	SPI_MISO	OUT	-
2	GND	GND	GND
3	SPI_CLK	IN	-
4	+V3P3A_SPI	PWR	+3.3V
5	SPI_MOSI	IN	-
6	SPI_CS	IN	-
7	NC	-	-

2.4.15 LVDS/eDP Connector (CN17)

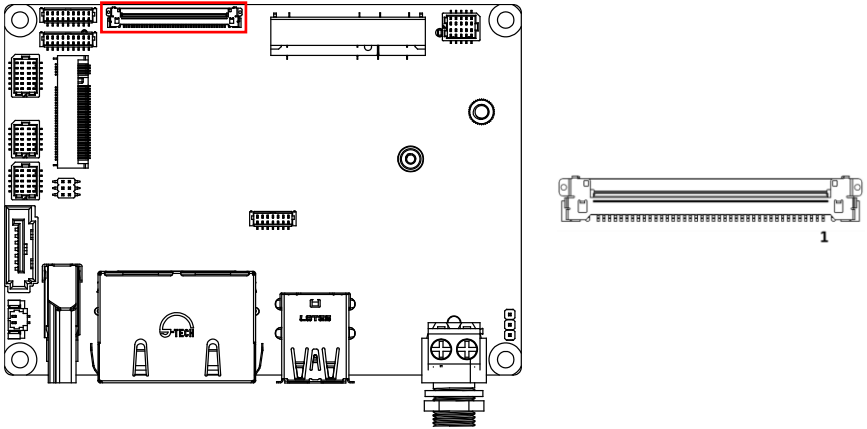

Pin	Pin Name	Signal Type	Signal Level
1	GND	GND	
2	LVD1_CB_3_DP	DIFF	
3	LVD1_CB_3_DN	DIFF	
4	GND	GND	
5	LVD1_CB_CLKP	DIFF	
6	LVD1_CB_CLKN	DIFF	
7	GND	GND	
8	LVD1_CB_2_DP	DIFF	
9	LVD1_CB_2_DN	DIFF	
10	GND	GND	
11	LVD1_CB_1_DP	DIFF	
12	LVD1_CB_1_DN	DIFF	
13	GND	GND	
14	LVD1_CB_0_DP	DIFF	
15	LVD1_CB_0_DN	DIFF	
16	GND	GND	
17	+V3P3S	PWR	+3.3V
18	LVD1_DDC_CLK/ DDIO_HPD	Signal	
19	LVD1_BKLTEN/DDIO_BKLTEN	Signal	
20	LVD1_DDC_DATA	Signal	
21	LVD1_BKLCTL/DDIO_BKLTCTL	Signal	
22	GND	GND	
23	LVD1_CA_CLKP/ DDIO_AUX_DP	DIFF	
24	LVD1_CA_CLKN/DDIO_AUX_DN	DIFF	

Pin	Pin Name	Signal Type	Signal Level
25	GND	GND	
26	LVD1_CA_3_DP/DDIO_LANE3_DP	DIFF	
27	LVD1_CA_3_DN/DDIO_LANE3_DN	DIFF	
28	GND	GND	
29	LVD1_CA_0_DP/DDIO_LANE0_DP	DIFF	
30	LVD1_CA_0_DN/DDIO_LANE0_DN	DIFF	
31	GND	GND	
32	LVD1_CA_1_DP/DDIO_LANE1_DP	DIFF	
33	LVD1_CA_1_DN/DDIO_LANE1_DN	DIFF	
34	GND	GND	
35	LVD1_CA_2_DP/DDIO_LANE2_DP	DIFF	
36	LVD1_CA_2_DN/DDIO_LANE2_DN	DIFF	
37	GND	GND	
38	+VDD	PWR	+3.3V
39	+VDD	PWR	+3.3V
40	+VDD	PWR	+3.3V

Note: The driving current of +VCC_EDP_BKLT supports up to 1.2A.

Note: The driving current of +VDD supports up to 1A.

2.4.16 COM Port 2 (CN18)

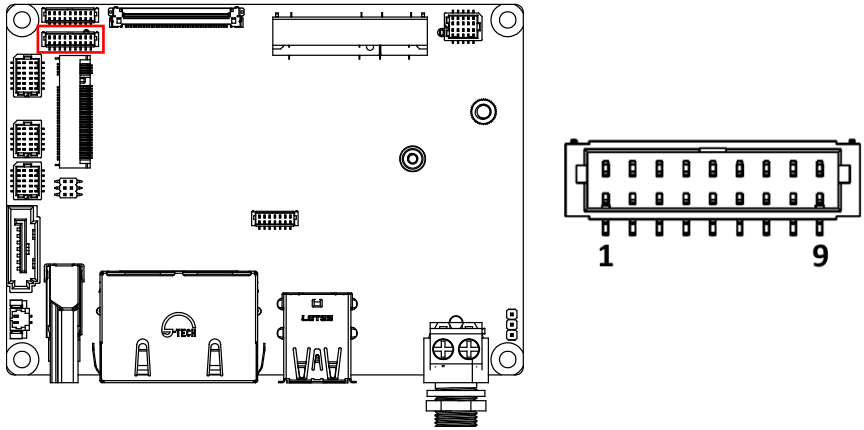

COM Port 2 RS-232 (Default)			
Pin	Pin Name	Signal Type	Signal Level
1	DCD1	IN	-
2	DSR1	IN	-

COM Port 2 RS-232 (Default)

Pin	Pin Name	Signal Type	Signal Level
3	RX1	IN	-
4	RTS1	OUT	±9V
5	TX1	OUT	±9V
6	CTS1	IN	-
7	DTR1	OUT	±9V
8	RI1/ +5V/ +12V	IN/ PWR	+5V/+12V
9	GND	GND	GND

COM Port 2 RS-422

Pin	Pin Name	Signal Type	Signal Level
1	RS422_TX-	OUT	±9V
2	NC	-	-
3	RS422_TX+	OUT	±9V
4	NC	-	-
5	RS422_RX+	IN	-
6	NC	-	-
7	RS422_RX-	IN	-
8	NC	-	-
9	GND	GND	GND

COM Port 2 RS-485

Pin	Pin Name	Signal Type	Signal Level
1	RS485_D-	IN/OUT	±9V
2	NC	-	-
3	RS485_D+	IN/OUT	±9V
4	NC	-	-
5	NC	-	-
6	NC	-	-
7	NC	-	-
8	NC	-	-
9	GND	GND	GND

Note: COM 2 RS-232/422/485 can be set by BIOS setting. Default is RS-232.

Note: Pin 8 function can be set by BOM.

2.4.17 M.2 2280 M-Key (CN19)

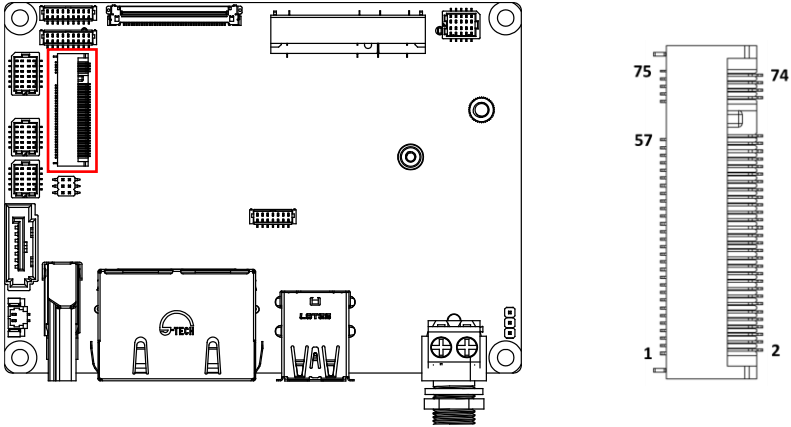

Pin	Pin Name	Signal Type	Signal Level
1	GND	GND	GND
2	+V3P3S	PWR	+3.3V
3	GND	GND	GND
4	+V3P3S	PWR	+3.3V
5	PCIE_12_RXN	DIFF	-
6	CARD_PWR_OFF_N	IN	-
7	PCIE_12_RXP	DIFF	-
8	NC	-	-
9	GND	GND	GND
10	PCH_SATA_LED_N	OUT	+3.3V
11	PCIE_12_TXN	DIFF	-
12	+V3P3S	PWR	+3.3V
13	PCIE_12_TXP	DIFF	-
14	+V3P3S	PWR	+3.3V
15	GND	GND	GND
16	+V3P3S	PWR	+3.3V
17	PCIE_11_RXN	DIFF	-
18	+V3P3S	PWR	+3.3V
19	PCIE_11_RXP	DIFF	-
20	NC	-	-
21	GND	GND	GND
22	KEYM_SSD_VIO	IN	-
23	PCIE_11_TXN	DIFF	-
24	NC	-	-

Pin	Pin Name	Signal Type	Signal Level
25	PCIE_11_TXP	DIFF	-
26	NC	-	-
27	GND	GND	GND
28	NC	-	-
29	PCIE_10_RXN	DIFF	-
30	NC	-	-
31	PCIE_10_RXP	DIFF	-
32	NC	-	-
33	GND	GND	GND
34	NC	-	-
35	PCIE_10_TXN	DIFF	-
36	NC	-	-
37	PCIE_10_TXP	DIFF	-
38	NC	-	-
39	GND	GND	GND
40	NC	-	-
41	PCIE_9_RXN/ SATA_1_RXP	DIFF	-
42	NC	-	-
43	PCIE_9_RXP/ SATA_1_RXN	DIFF	-
44	NC	-	-
45	GND	GND	GND
46	NC	-	-
47	PCIE_9_TXN/ SATA_1_TXN	DIFF	-
48	NC	-	-
49	PCIE_9_TXP/ SATA_1_TXP	DIFF	-
50	BUF_PLT_RST#	IN	-
51	GND	GND	GND
52	M2M_CLKREQ#	OUT	-
53	PCIE_5_CLK_DN	DIFF	-
54	PCIE_WAKE#	OUT	-
55	PCIE_5_CLK_DP	DIFF	-
56	NC	-	-
57	GND	GND	GND
58	NC	-	-
67	NC	-	-

Pin	Pin Name	Signal Type	Signal Level
68	SUS_CLK	IN	-
69	KEYM_DET	IN	-
70	+V3P3S	PWR	+3.3V
71	GND	GND	GND
72	+V3P3S	PWR	+3.3V
73	GND	GND	GND
74	+V3P3S	PWR	+3.3V
75	GND	GND	GND

2.4.18 Dual RJ-45 LAN Port (CN20)

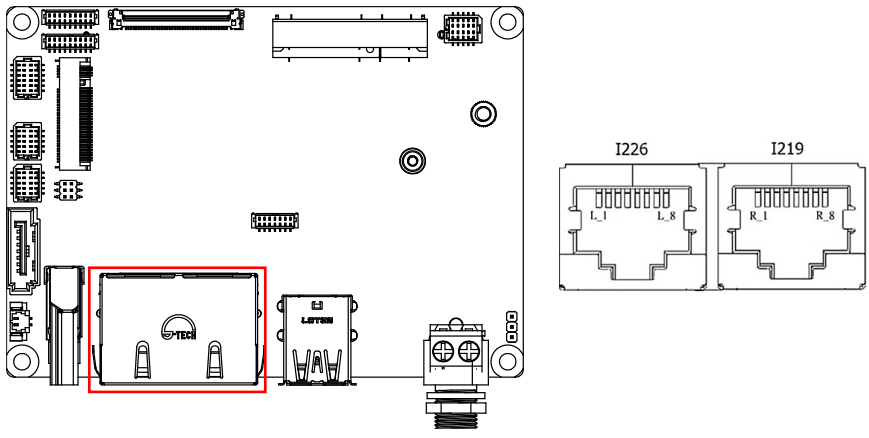

Pin	Pin Name	Signal Type	Signal Level
L_1	LAN1_MDI0_P	DIFF	-
L_2	LAN1_MDI0_N	DIFF	-
L_3	LAN1_MDI1_P	DIFF	-
L_4	LAN1_MDI1_N	DIFF	-
L_5	LAN1_MDI2_P	DIFF	-
L_6	LAN1_MDI2_N	DIFF	-
L_7	LAN1_MDI3_P	DIFF	-
L_8	LAN1_MDI3_N	DIFF	-
R_1	LAN2_MDI0_P	DIFF	-
R_2	LAN2_MDI0_N	DIFF	-
R_3	LAN2_MDI1_P	DIFF	-
R_4	LAN2_MDI1_N	DIFF	-
R_5	LAN2_MDI2_P	DIFF	-
R_6	LAN2_MDI2_N	DIFF	-

Pin	Pin Name	Signal Type	Signal Level
R_7	LAN2_MDI3_P	DIFF	-
R_8	LAN2_MDI3_N	DIFF	-

Note: Left port: Intel® Ethernet Controller I226.

Note: Right port: Intel® Ethernet Connection I219.

2.4.19 HDMI Port (CN21)

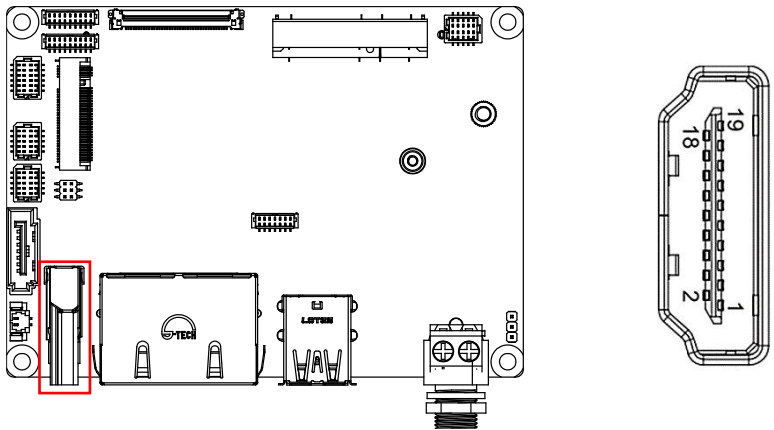

Pin	Pin Name	Signal Type	Signal Level
1	HDMI_TX2+	DIFF	-
2	GND	GND	GND
3	HDMI_TX2-	DIFF	-
4	HDMI_TX1+	DIFF	-
5	GND	GND	GND
6	HDMI_TX1-	DIFF	-
7	HDMI_TX0+	DIFF	-
8	GND	GND	GND
9	HDMI_TX0-	DIFF	-
10	HDMI_CLK+	DIFF	-
11	GND	GND	GND
12	HDMI_CLK-	DIFF	-
13	N/A	N/A	N/A
14	N/A	N/A	N/A
15	DDC_CLK	IN/OUT	-
16	DDC_DATA	IN/OUT	-
17	GND	GND	GND

Pin	Pin Name	Signal Type	Signal Level
18	+V5S	PWR	+5V
19	HDMI_HPD	IN	-

2.4.20 Port 80 Debug Port/SMBus/I2C (CN22)

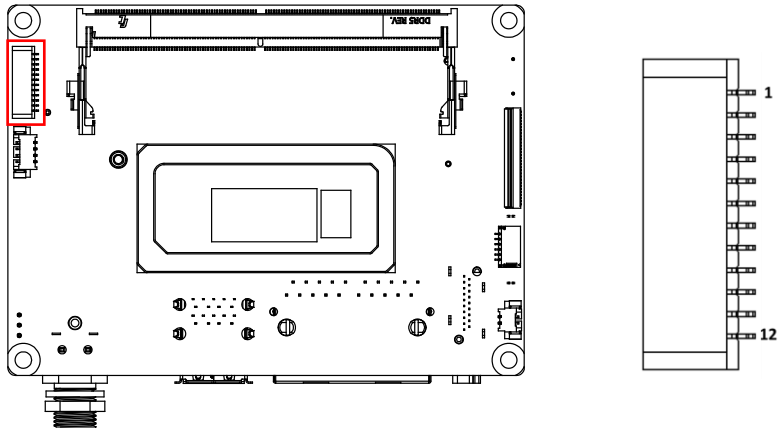

Pin	Pin Name	Signal Type	Signal Level
1	ESPI_IO0	IN/OUT	+1.8V
2	ESPI_IO1	IN/OUT	+1.8V
3	ESPI_IO2	IN/OUT	+1.8V
4	ESPI_IO3	IN/OUT	+1.8V
5	+V3P3S	PWR	+3.3V
6	ESPI_CS	IN	-
7	ESPI_RST#	OUT	+3.3V
8	GND	GND	GND
9	ESPI_CLK	OUT	+1.8V
10	SMB_DATA/ I2C_SDA	IN/OUT	+3.3V
11	SMB_CLK/ I2C_CLK	OUT	+3.3V
12	SMB_ALERT/ INT_SERIRQ	IN	+3.3V

2.4.21 RTC Battery Connector (CN24)

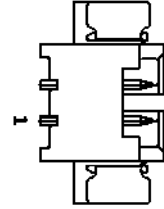
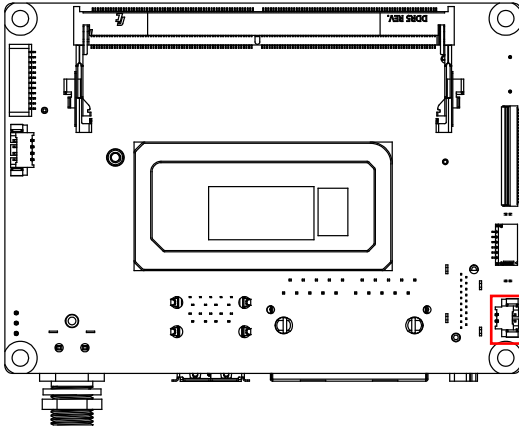

Pin	Pin Name	Signal Type	Signal Level
1	+3.3V	PWR	+3.3V
2	GND	GND	GND

2.4.22 Dual USB 3.2 Port (CN30)

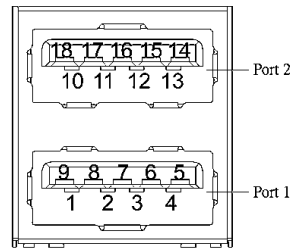
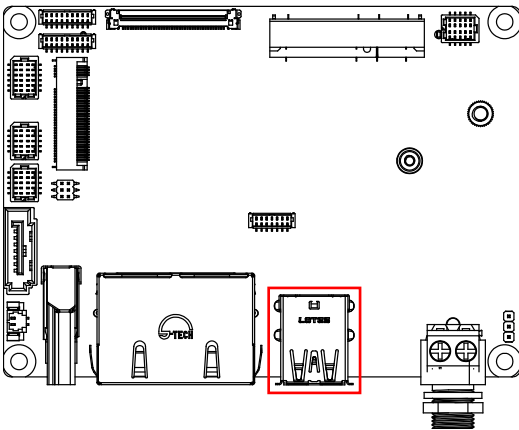

Pin	Pin Name	Signal Type	Signal Level
1	+5VSB	PWR	+5V
2	USB2_1_DN	DIFF	-
3	USB2_1_DP	DIFF	-
4	GND	GND	GND
5	USB3_1_RXN	DIFF	-

Pin	Pin Name	Signal Type	Signal Level
6	USB3_1_RXP	DIFF	-
7	GND	GND	GND
8	USB3_1_TXN	DIFF	-
9	USB3_1_TXP	DIFF	-
10	+5VSB	PWR	+5V
11	USB2_2_DN	DIFF	-
12	USB2_2_DP	DIFF	-
13	GND	GND	GND
14	USB3_2_RXN	DIFF	-
15	USB3_2_RXP	DIFF	-
16	GND	GND	GND
17	USB3_2_TXN	DIFF	-
18	USB3_2_TXP	DIFF	-

Note: The driving current of +5VSB supports up to 0.9A/Port.

2.4.23 Terminal Block DC Input Connector (CN36)

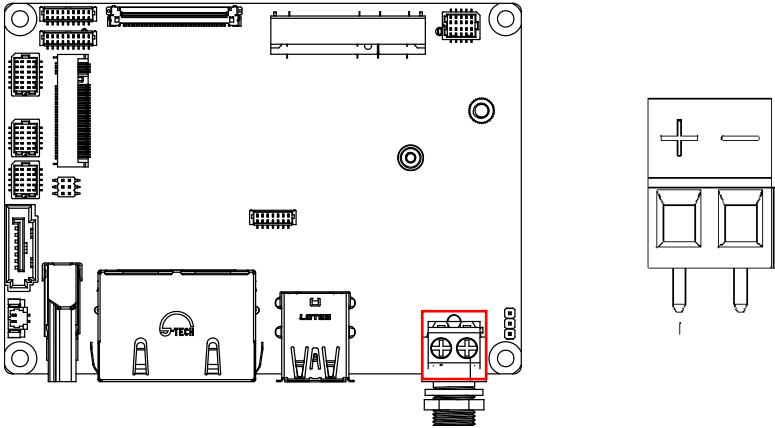

Pin	Pin Name	Signal Type	Signal Level
1	+VIN	PWR	+12V
2	GND	GND	GND

2.4.24 USB 2.0 Port 1/Port 2 (CN38)

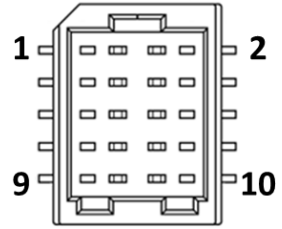
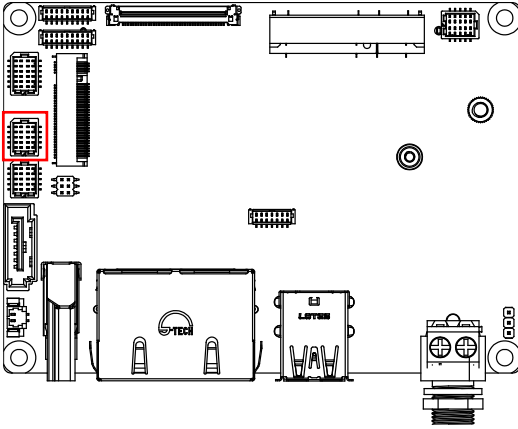

Pin	Pin Name	Signal Type	Signal Level
1	+5VSB	PWR	+5V
2	+5VSB	PWR	+5V
3	USB2_5_DN	DIFF	-
4	USB2_6_DN	DIFF	-
5	USB2_5_DP	DIFF	-
6	USB2_6_DP	DIFF	-
7	GND	GND	GND
8	GND	GND	GND
9	GND	GND	GND
10	GND	GND	GND

Note: The driving current of +5VSB supports up to 0.5A/Port.

2.5 Thermal Assembly Options

2.5.1 Fan Assembly

Fan Part Number: PICO-RAP4-FAN01.

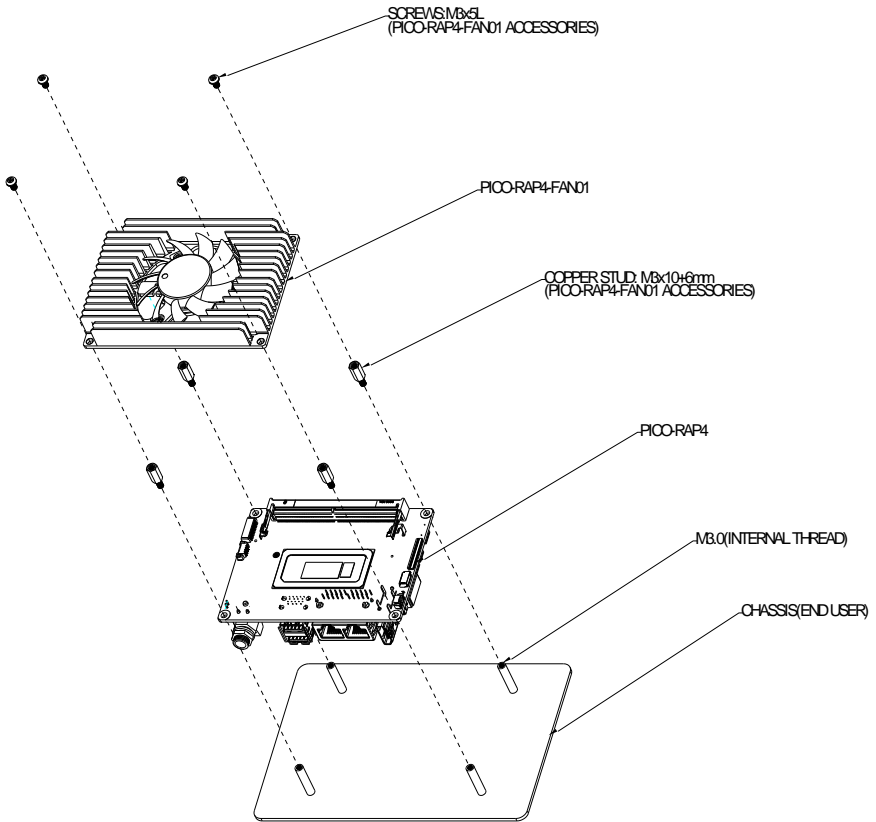

2.5.2 Heatspreader Assembly

Heatspreader Part Number: PICO-RAP4-HSP01.

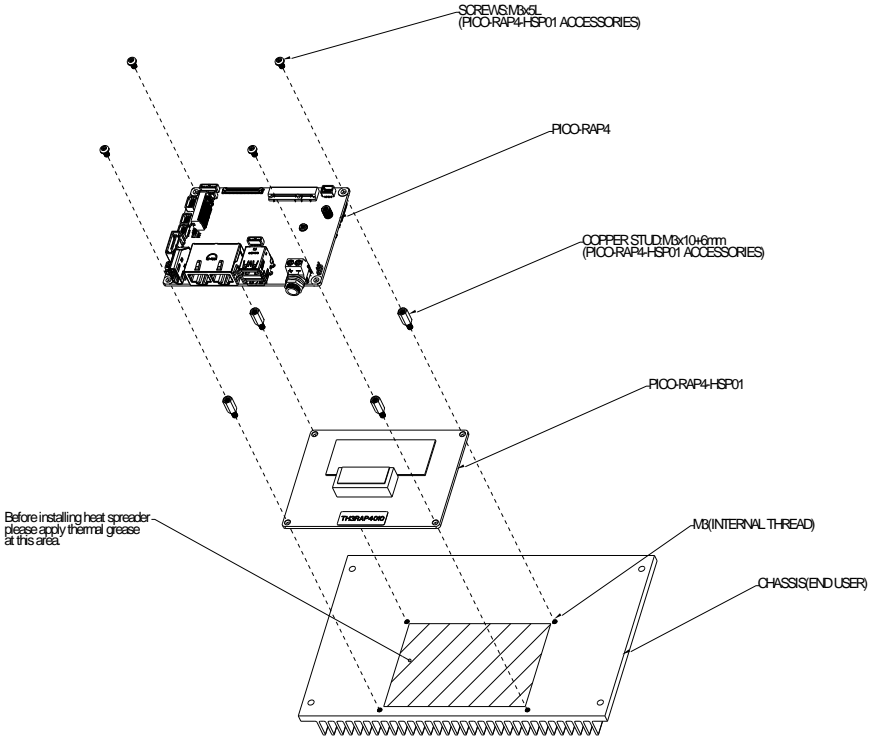

Chapter 3

AMI BIOS Setup

3.1 System Test and Initialization

These routines test and initialize board hardware. If the routines encounter an error during the tests, you will either hear a few short beeps or see an error message on the screen. There are two kinds of errors: fatal and non-fatal. The system can usually continue the boot up sequence with non-fatal errors.

System configuration verification

These routines check the current system configuration stored in the CMOS memory and BIOS NVRAM. If system configuration is not found or system configuration data error is detected, system will load optimized default and re-boot with this default system configuration automatically.

There are four situations in which you will need to setup system configuration:

1. You are starting your system for the first time
2. You have changed the hardware attached to your system
3. The system configuration is reset by Clear-CMOS jumper
4. The CMOS memory has lost power and the configuration information has been erased.

The PICO-RAP4 CMOS memory has an integral lithium battery backup for data retention. However, you will need to replace the battery when it finally runs down.

3.2 AMI BIOS Setup

AMI BIOS ROM has a built-in Setup program that allows users to modify the basic system configuration. This type of information is stored in battery-backed CMOS RAM and BIOS NVRAM so that it retains the Setup information when the power is turned off.

Entering Setup

Power on the computer and press or <ESC> immediately. This will allow you to enter Setup.

Main

Set the date, use tab to switch between date elements.

Advanced

Enable/disable boot option for legacy network devices.

Chipset

Host bridge parameters.

Security

Set setup administrator password.

Boot

Enables/disables quiet boot option.

Save & Exit

Exit system setup after saving the changes.

Intel® AMT Configuration

Configure user content preferences.

3.3 Setup Submenu: Main

Aptio Setup - AMI

Main Advanced Chipset Security Boot Save & Exit MEBx

BIOS Information PICO-RAP4 R1.0 (ZRP4AM10) (04/26/2024)	Set the Date. Use Tab to switch between Date elements. Default Ranges: Year: 1998-9999 Months: 1-12 Days: Dependent on month Range of Years may vary.
BIOS Vendor Compliance	American Megatrends UEFI 2.8; PI 1.7
System Date System Time	[Mon 04/29/2024] [00:27:56]
Access Level	Administrator

+ -: Select Screen
t1: Select Item
Enter: Select
+/-: Change Opt.
F1: General Help
F2: Previous Values
F3: Optimized Defaults
F4: Save & Exit
ESC: Exit

Version 2.22.1290 Copyright (C) 2024 AMI

3.4 Setup Submenu: Advanced

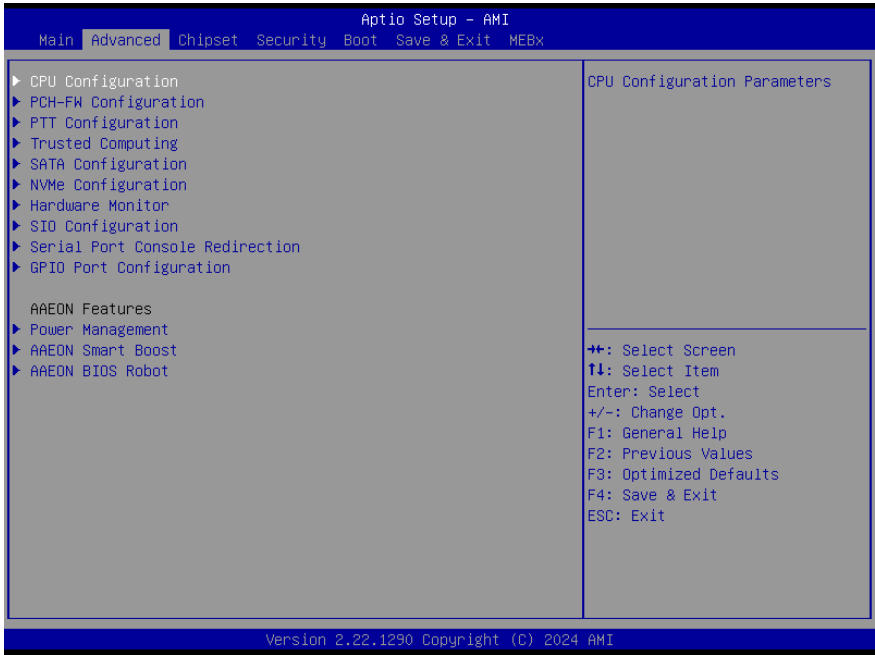

3.4.1 CPU Configuration

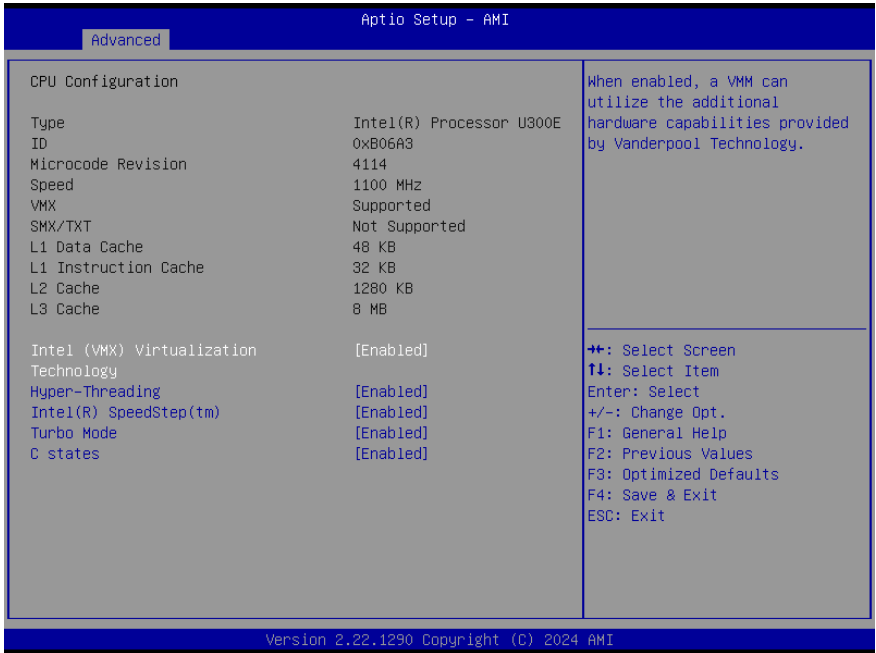

Options Summary		
Intel (VMX) Virtualization Technology	Disabled	
	Enabled	Optimal Default, Failsafe Default
When enabled, a VMM can utilize the additional hardware capabilities provided by Vanderpool Technology.		
Hyper-Threading	Disabled	
	Enabled	Optimal Default, Failsafe Default
Enable or Disable Hyper-Threading Technology.		
Intel(R) SpeedStep(tm)	Disabled	
	Enabled	Optimal Default, Failsafe Default
Allows more than two frequency ranges to be supported		
Turbo Mode	Disabled	
	Enabled	Optimal Default, Failsafe Default
Enable or Disable processor Turbo Mode (requires EMTTM enable too). AUTO means enabled.		

Options Summary		
C states	Disabled	
	Enabled	Optimal Default, Failsafe Default
Enable/Disable CPU Power Management. Allows CPU to go to C states when it's not 100% utilized		

3.4.2 PCH-FW Configuration

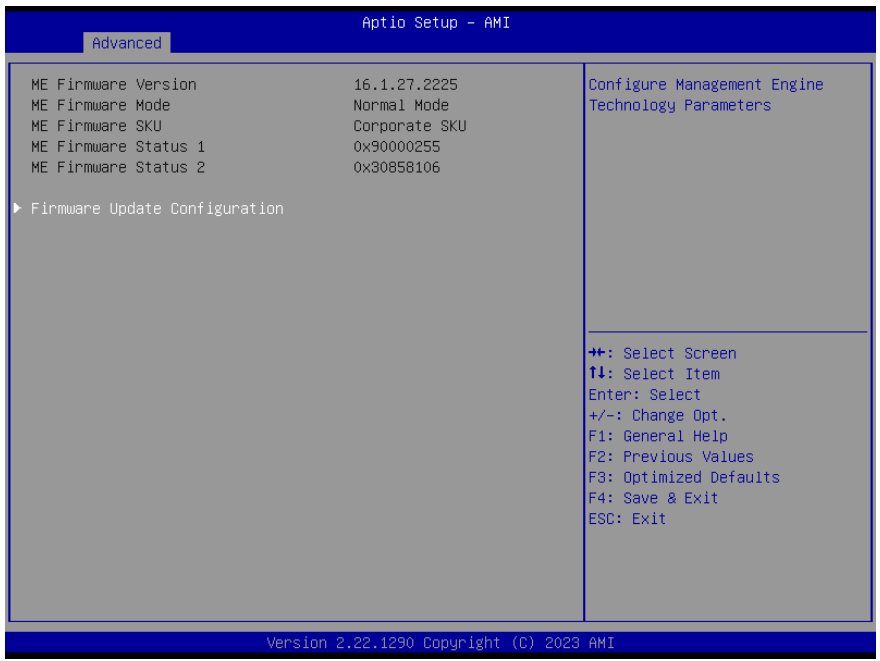

3.4.3 Firmware Update Configuration

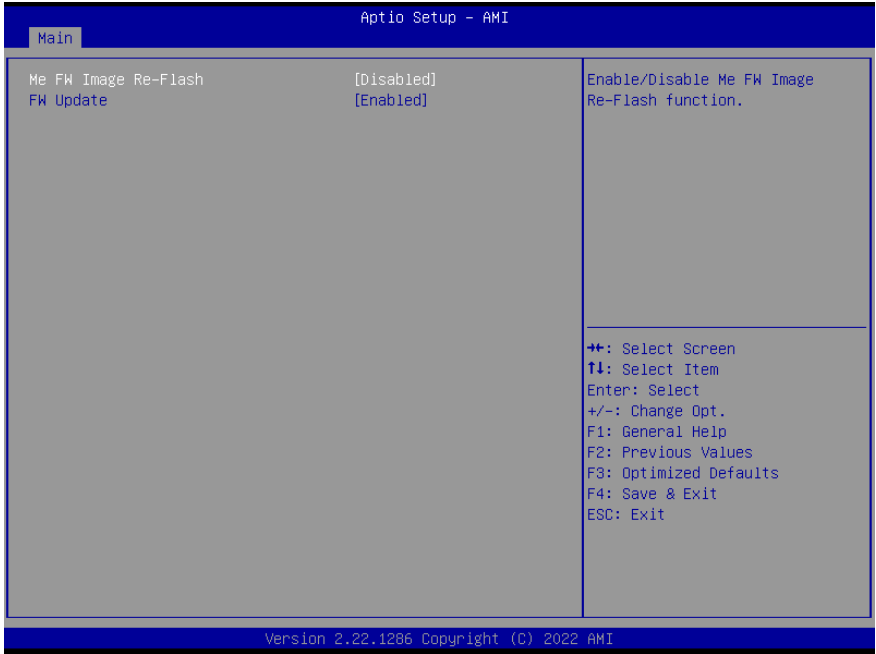

Options Summary		
Me FW Image Re-Flash	Enabled	
	Disabled	Optimal Default, Failsafe Default
Enable/Disable Me FW Image Re-Flash function.		
FW Update	Disabled	
	Enabled	Optimal Default, Failsafe Default
Enable/Disable ME FW Update function.		

3.4.4 PTT Configuration



Options Summary		
TPM Device Selection	dTPM	Optimal Default, Failsafe Default
	PTT	
<p>Selects TPM device: PTT or discrete TPM. PTT - enables PTT in SkuMgr dTPM - disables PTT in SkuMgr. Warning: PTT/dTPM will be disabled and all data saved on it will be lost.</p>		

3.4.5 Trusted Computing



Options Summary		
Security Device Support	Enable	Optimal Default, Failsafe Default
	Disable	
Enables or Disables BIOS support for security device. O.S. will not show Security Device. TCG EFI protocol and INT1A interface will not be available.		
SHA256 PCR Bank	Enabled	Optimal Default, Failsafe Default
	Disabled	
Enable or Disable SHA256 PCR Bank.		
SHA384 PCR Bank	Enabled	Optimal Default, Failsafe Default
	Disabled	
Enable or Disable SHA384 PCR Bank.		
Pending operation	None	Optimal Default, Failsafe Default
	TPM Clear	
Schedule an Operation for the Security Device. NOTE: Your Computer will reboot during restart in order to change State of Security Device.		

Options Summary		
Platform Hierarchy	Enabled	Optimal Default, Failsafe Default
	Disabled	
Enable or Disable Platform Hierarchy		
Storage Hierarchy	Enabled	Optimal Default, Failsafe Default
	Disabled	
Enable or Disable Storage Hierarchy		
Endorsement Hierarchy	Enabled	Optimal Default, Failsafe Default
	Disabled	
Enable or Disable Endorsement Hierarchy		
Physical Presence Spec Version	1.3	Optimal Default, Failsafe Default
	1.2	
Select to Tell O.S. to support PPI Spec Version 1.2 or 1.3. Note some HCK tests might not support 1.3		
Device Select	Auto	
	TPM 1.2	
	TPM 2.0	Optimal Default, Failsafe Default
TPM 1.2 will restrict support to TPM 1.2 devices. TPM 2.0 will restrict support to TPM 2.0 devices. Auto will support both with the default set to TPM 2.0 devices if not found. TPM 1.2 devices will be enumerated.		

3.4.6 SATA Configuration

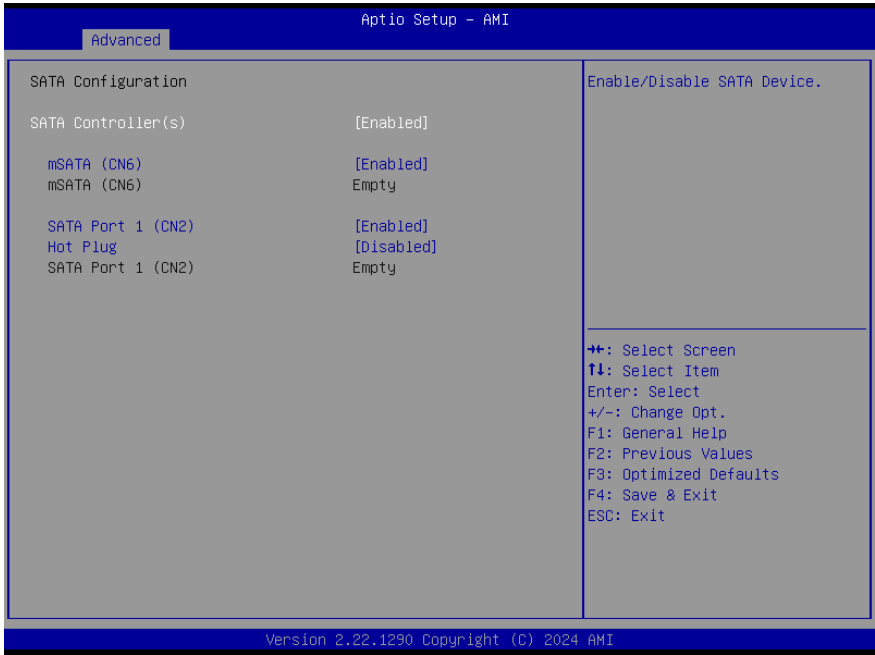

Options Summary		
SATA Controller(s)	Enabled	Optimal Default, Failsafe Default
	Disabled	
Enable/Disable SATA Device.		
mSATA (CN6)	Enabled	Optimal Default, Failsafe Default
	Disabled	
Enable or Disable SATA Port.		
SATA Port 1 (CN2)	Enabled	Optimal Default, Failsafe Default
	Disabled	
Enable or Disable SATA Port.		
Hot Plug	Disabled	Optimal Default, Failsafe Default
	Enabled	
Designates this port as Hot Pluggable.		

3.4.7 NVMe Configuration

PICO-ITX Board

PICO-RAP4

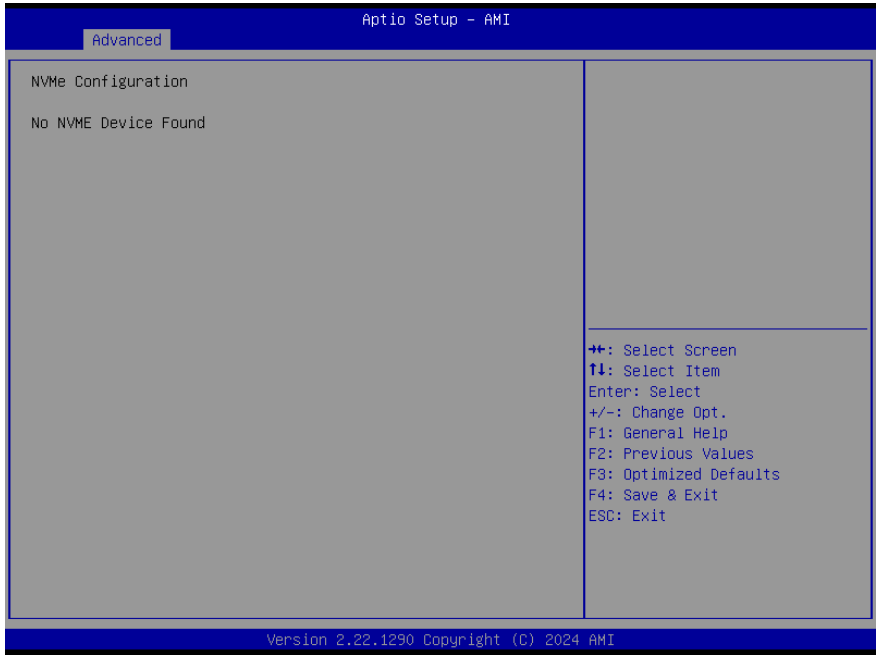

3.4.8 Hardware Monitor

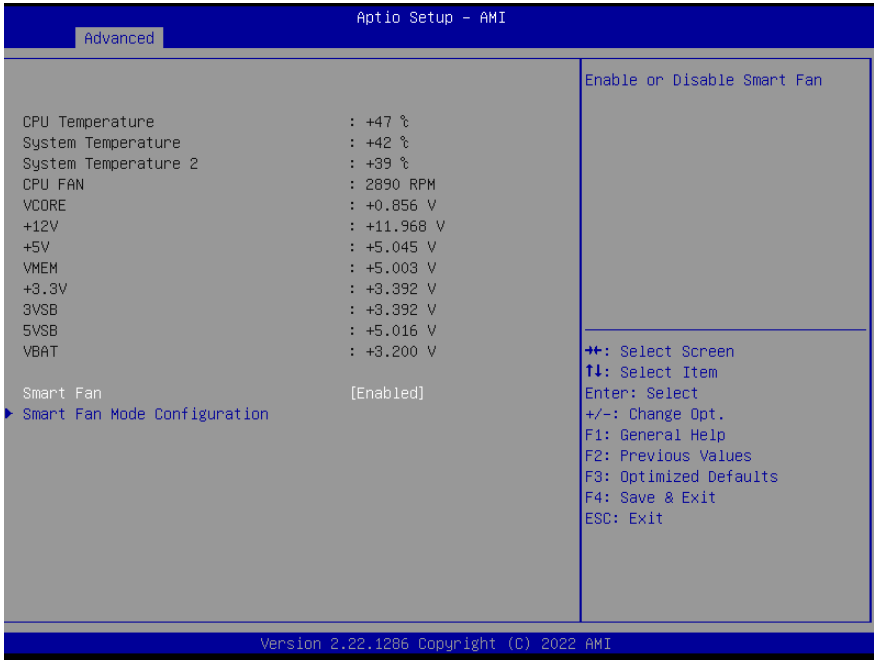

Options Summary		
Smart Fan	Disable	
	Enable	Optimal Default, Failsafe Default
Enables or Disables Smart Fan.		

3.4.8.1 Smart Fan Mode Configuration

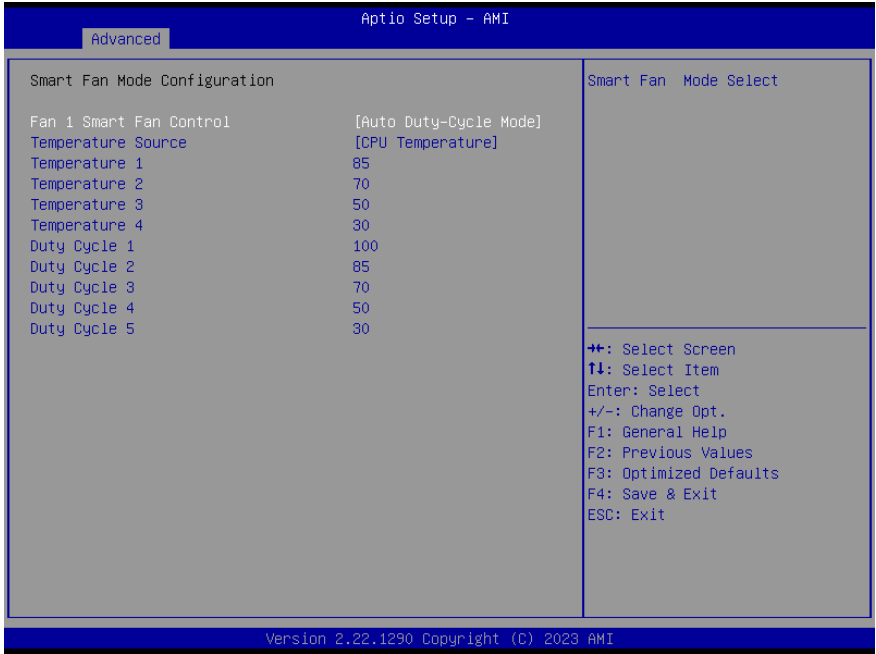

Options Summary		
Fan 1 Smart Fan Control	Manual Duty Mode	
	Auto Duty-Cycle Mode	Optimal Default, Failsafe Default
Smart Fan Mode Select.		
Temperature Source	CPU Temperature	
	System Temperature	
	System Temperature 2	Optimal Default, Failsafe Default
Select the monitored temperature source for this fan.		
Temperature 1	60	
Duty Cycle 1	85	
Auto fan speed control. Fan speed will follow different temperature by different duty cycle 1-100.		

3.4.9 SIO Configuration



3.4.9.1 Serial Port 1 Configuration

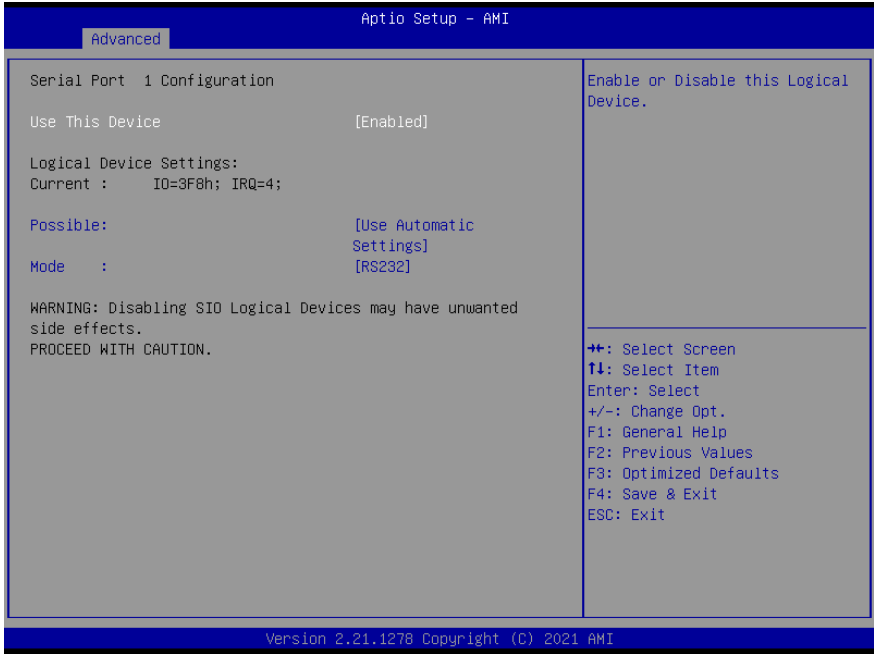

Options Summary		
Use This Device	Disable	
	Enable	Optimal Default, Failsafe Default
Enable or Disable this Logical Device.		
Possible:	Use Automatic Settings	Optimal Default, Failsafe Default
	IO=3F8h; IRQ=4	
	IO=2F8h; IRQ=3	
Allows user to change Device's Resource settings. New settings will be reflected on This Setup Page after System restarts.		
Mode:	RS232	Optimal Default, Failsafe Default
	RS422	
	RS485	
UART RS232, 422, 485 selection.		

3.4.9.2 Serial Port 2 Configuration

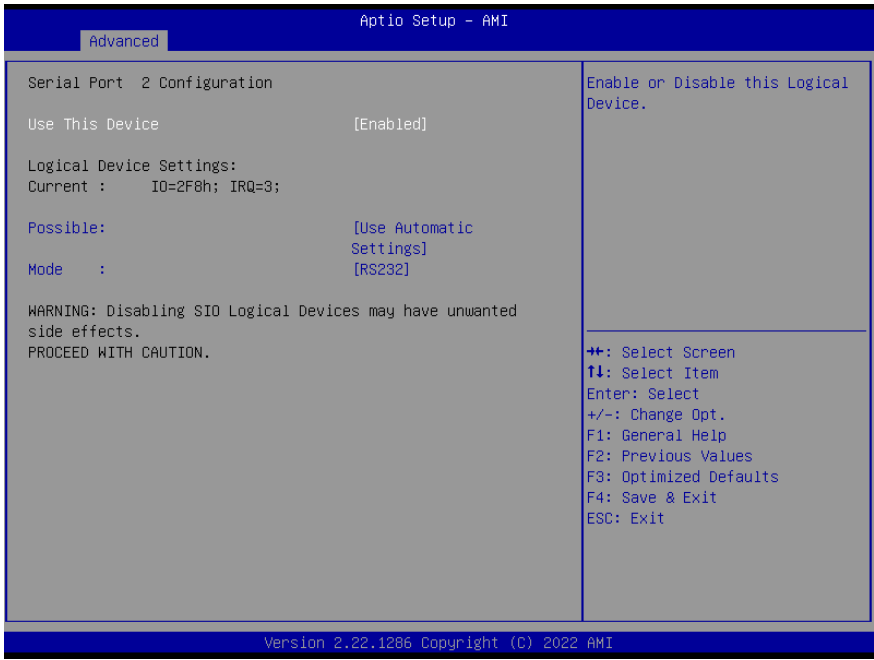

Options Summary		
Use This Device	Disable	
	Enable	Optimal Default, Failsafe Default
Enable or Disable this Logical Device.		
Possible:	Use Automatic Settings	Optimal Default, Failsafe Default
	IO=3F8h; IRQ=4	
	IO=2F8h; IRQ=3	
Allows user to change Device's Resource settings. New settings will be reflected on This Setup Page after System restarts.		
Mode:	RS232	Optimal Default, Failsafe Default
	RS422	
	RS485	
UART RS232, 422, 485 selection.		

3.4.10 Serial Port Console Redirection

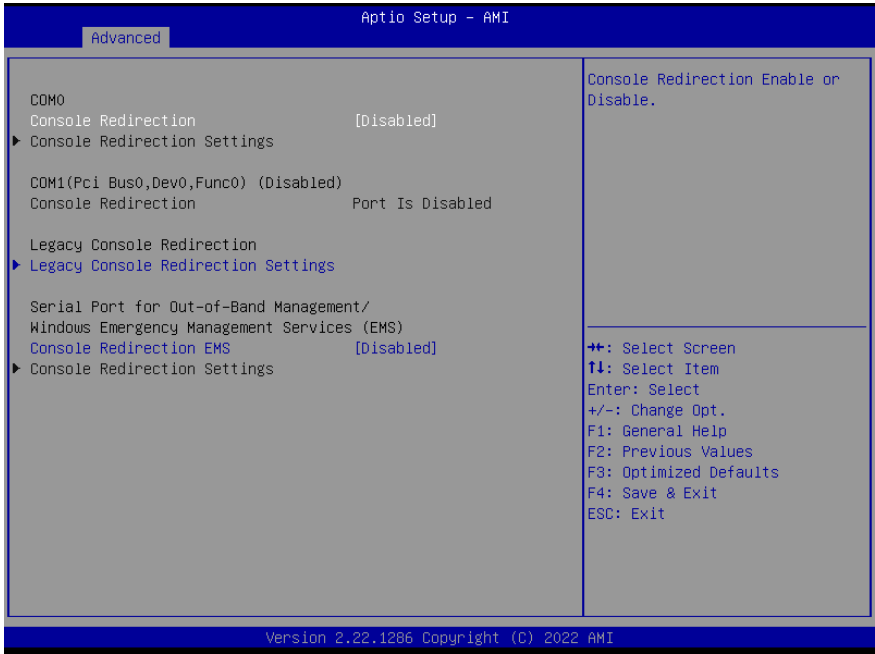

Options Summary		
Console Redirection	Disabled	Optimal Default, Failsafe Default
	Enabled	
Console Redirection Enable or Disable.		
Console Redirection EMS	Disabled	Optimal Default, Failsafe Default
	Enabled	
Console Redirection Enable or Disable.		

3.4.11 Legacy Console Redirection Settings

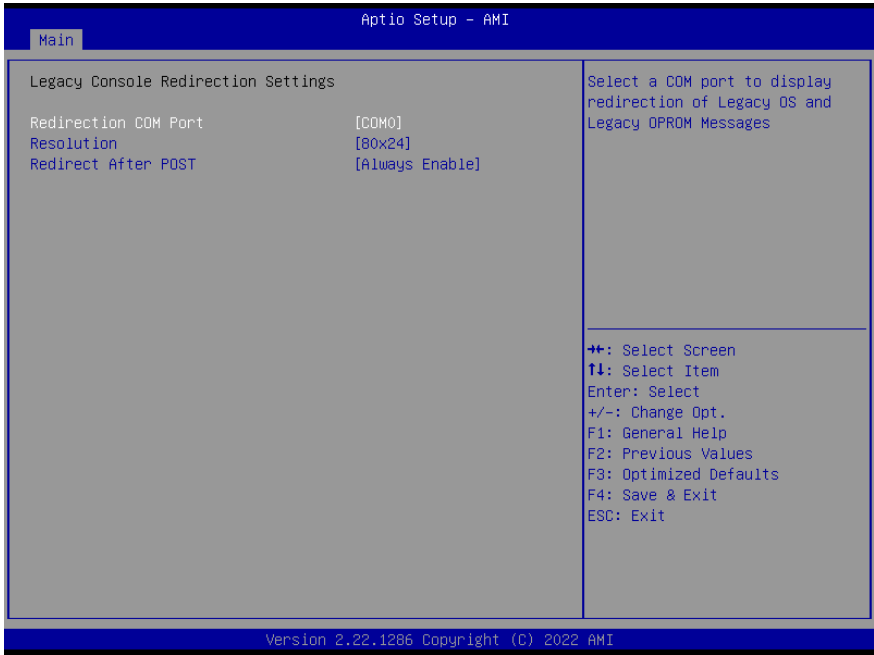

Options Summary		
Redirection COM Port	COM0	Optimal Default, Failsafe Default
	COM1(Pci Bus0, Dev0, Func0) (Disabled)	
Select a COM Port to display redirection of Legacy OS and Legacy OPRM message.		
Resolution	80x24	Optimal Default, Failsafe Default
	80x25	
On Legacy OS, the number of Rows and Columns supported redirection.		
Redirect After POST	Always Enable	Optimal Default, Failsafe Default
	BootLoader	
<p>Legacy Console Redirection behavior after POST.</p> <p>BootLoader – Legacy Console Redirection is disabled before booting to a legacy operating system.</p> <p>Always Enable – Legacy Console Redirection remains enabled when booting to a legacy operating system.</p> <p>The default setting for this option is Always Enable.</p>		

3.4.12 GPIO Port Configuration



Options Summary		
GPIO Port*	Output	
	Input	
Set GPIO as Input or Output.		
Output Level	High	
	Low	
Set output level when GPIO pin is output.		

3.4.13 Power Management

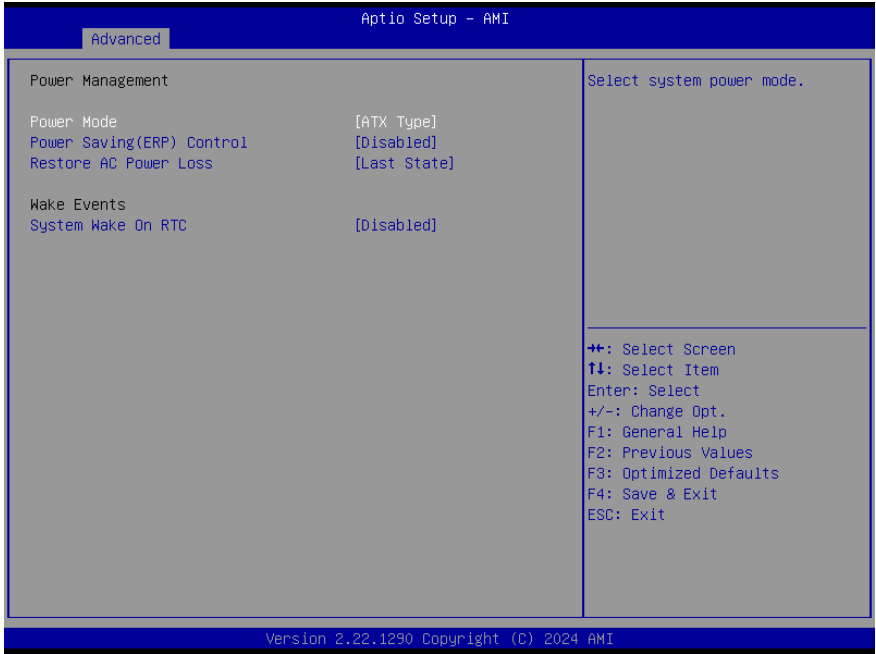

Options Summary		
Power Mode	ATX Type	Optimal Default, Failsafe Default
	AT Type	
Select power supply mode.		
Restore AC Power Loss	Last State	Optimal Default, Failsafe Default
	Always On	
	Always Off	
Select power state when power is re-applied after a power failure.		
RTC wake system from S5	Disable	Optimal Default, Failsafe Default
	Fixed Time	
	Bypass	
Fixed Time: System will wake on the hr::min::sec specified.		
Bypass: BIOS will not control RTC wake function during system shutdown.		

3.4.14 AAEON Smart Boost

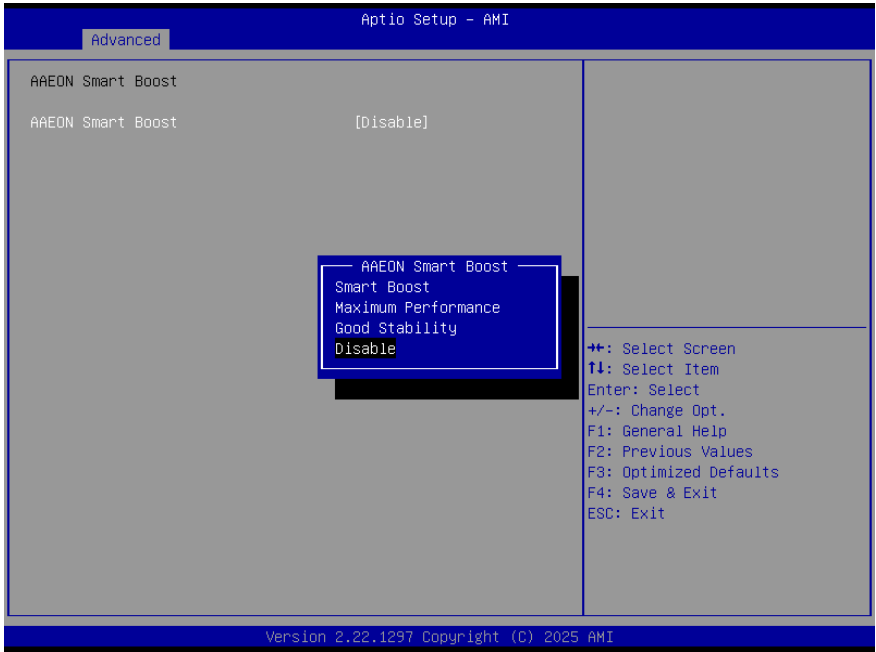

Options Summary		
AAEON Smart Boost	Disable	Optimal Default, Failsafe Default
	Smart Boost	
	Maximum Performance	
	Good Stability	
Control AAEON Smart Boost feature.		

3.4.15 AAEON BIOS Robot

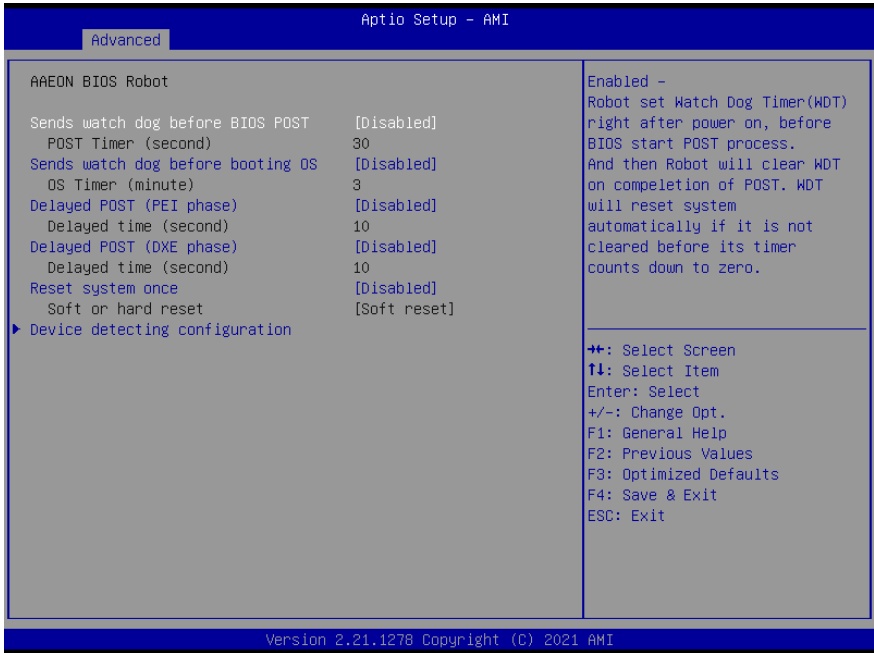

Options Summary		
Sends watch dog before BIOS POST	Disabled	Optimal Default, Failsafe Default
	Enabled	
Enabled – The robot sets the WDT immediately after power-on, before the BIOS starts the POST process. The robot clears the WDT after POST is completed. If the WDT is not cleared before the timer expires, the system will automatically reset.		
POST Timer (second)	30	Optimal Default, Failsafe Default
Set the Watchdog Timer (WDT) duration for POST in seconds.		
Warning: Do not set this value equal to or shorter than the normal POST time, as the system may fail to complete POST unless BIOS settings are cleared. A value greater than 2× the normal POST time is recommended.		
Sends watch dog before booting OS	Disabled	Optimal Default, Failsafe Default
	Enabled	

Options Summary

Enable or disable sending the Watchdog Timer (WDT) after POST completion and before the BIOS transfers control to the operating system.

Enabled – The robot sets the WDT after POST is completed. The operating system must run a program to regularly clear the WDT.

Warning: Disable this function during OS updates, as the system may reset if the WDT is not cleared.

OS Timer (minute)	3	Optimal Default, Failsafe Default

Timer count set to Watch Dog Timer for OS loading.

Delayed POST (PEI phase)	Disabled	Optimal Default, Failsafe Default
	Enabled	

Enabled – The robot holds the BIOS from starting POST immediately after power-on. This ensures POST begins with stable power or after the system is physically warmed up.

Note: This action occurs before sending the Watchdog Timer.

Delayed time (second)	10	Optimal Default, Failsafe Default

Period of time for Robot to hold BIOS from POST.

Delayed POST (DXE phase)	Disabled	Optimal Default, Failsafe Default
	Enabled	

Enable or disable delayed POST during the DXE phase.

Enabled – The robot holds the BIOS before POST completion. This allows POST to start with stable power or after the system is physically warmed up.

Note: This action occurs after sending the Watchdog Timer before BIOS POST.

Delayed time (second)	10	Optimal Default, Failsafe Default

Period of time for Robot to hold BIOS from POST.

Reset system once	Disabled	Optimal Default, Failsafe Default
	Enabled	

Enabled - Robot resets system for one time on each boot. This will send a soft or hard reset to onboard devices, thus puts devices to more stable state.

Soft or hard reset	Soft reset	Optimal Default, Failsafe Default
	Hard reset"	

Select reset type robot should send on each boot.

3.5 Setup Submenu: Chipset



3.5.1 System Agent (SA) Configuration



Options Summary		
VT-d	Disabled	Optimal Default, Failsafe Default
	Enabled	
VT-d capability.		

3.5.2 Memory Configuration

The screenshot shows the BIOS setup interface for the PICO-RAP4 board. The title bar reads "Aptio Setup - AMI". A "Chipset" tab is selected. The "Memory Configuration" section is active, displaying the following information:

Memory Configuration	
Memory RC Version	0.0.4.133
Total Memory	8192 MB
MC 0 Ch 0 DIMM 0	Populated & Enabled
Size	8192 MB (DDR5)
Number of Ranks	1

Navigation instructions are listed in the bottom right corner:

- ←→: Select Screen
- ↑↓: Select Item
- Enter: Select
- +/-: Change Opt.
- F1: General Help
- F2: Previous Values
- F3: Optimized Defaults
- F4: Save & Exit
- ESC: Exit

At the bottom of the screen, the text "Version 2.22.1290 Copyright (C) 2024 AMI" is displayed.

3.5.3 LVDS Panel Configuration

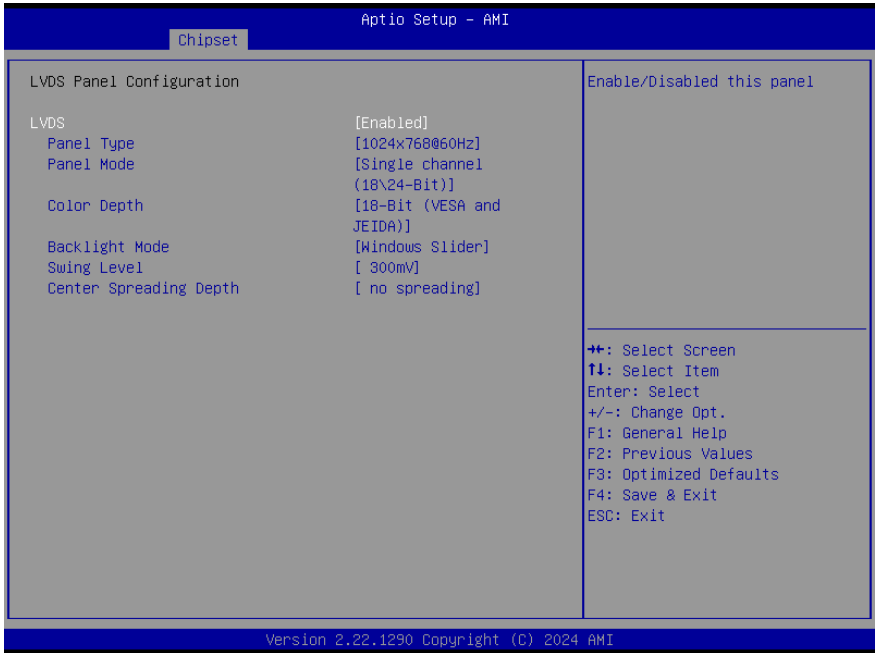

Options Summary		
LVDS	Disabled	
	Enabled	Optimal Default, Failsafe Default
Enable/Disabled this panel.		
LVDS Panel Type	640X480@60HZ	
	800X480@60HZ	
	800X600@60HZ	
	1024X600@60HZ	
	1024X768@60HZ	Optimal Default, Failsafe Default
	1280X768@60HZ	
	1280X800@60HZ	
	1280X1024@60HZ	
	1366X768@60HZ	
	1440X900@60HZ	
	1600X1200@60HZ	
	1920X1080@60HZ	

Options Summary		
LVDS Panel Type (Cont.)	1920X1200@60HZ	
Select LCD panel used by Internal Graphics Device by selecting the appropriate setup item.		
Panel Mode	Single channel (18\24-Bit)	Optimal Default, Failsafe Default
	Dual channel (36/48-Bit)	
Panel mode selection for single channel and dual channel.		
Color Depth	18-bit (VESA and JEIA)	Optimal Default, Failsafe Default
	24-bit (VESA)	
	24-bit (JEIDA)	
Select color depth.		
Backlight Mode	BIOS & Application	
	Windows Slider	Optimal Default, Failsafe Default
Select backlight control signal type.		
Backlight Type	Normal	Optimal Default, Failsafe Default
	Inverted	
Select backlight control signal type.		
Backlight Level	0%	
	10%	
	20%	
	30%	
	40%	
	50%	
	60%	
	70%	
	80%	Optimal Default, Failsafe Default
	90%	
100%		
Select backlight control level.		
Backlight PWM Freq	100Hz	
	200Hz	
	220Hz	Optimal Default, Failsafe Default
	500Hz	
	1.1KHz	
	2.2KHz	
	6.5KHz	
Select PWM frequency of backlight control signal.		
Swing Level	150mV	
	200mV	

Options Summary		
Swing Level (Cont.)	250mV	
	300mV	Optimal Default, Failsafe Default
	350mV	
	400mV	
	450mV	
Select Swing Level.		
Center Spreading Depth	no spreading	Optimal Default, Failsafe Default
	0.5%	
	1.0%	
	1.5%	
	2.0%	
	2.5%	
Select Center Spreading Depth.		

3.5.4 PCH-IO Configuration

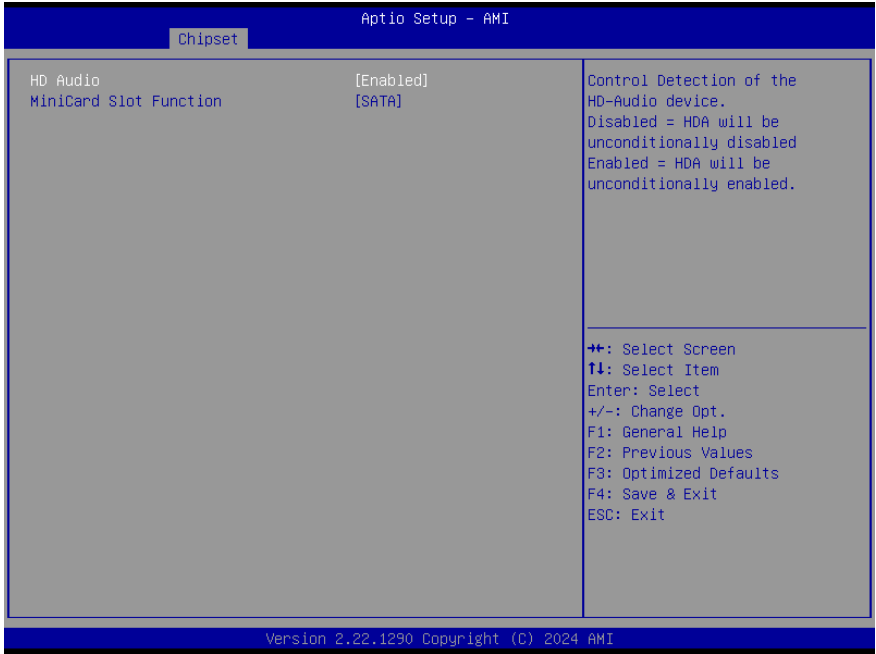

Options Summary		
HD Audio	Disabled	
	Enabled	Optimal Default, Failsafe Default
Control Detection of the HD-Audio device. Disabled = HDA will be unconditionally disabled. Enabled = HDA will be unconditionally enabled.		
MiniCard Slot Function	SATA	Optimal Default, Failsafe Default
	PCIe	
Select function enabled for mini card slot (CN6).		

3.6 Setup Submenu: Security

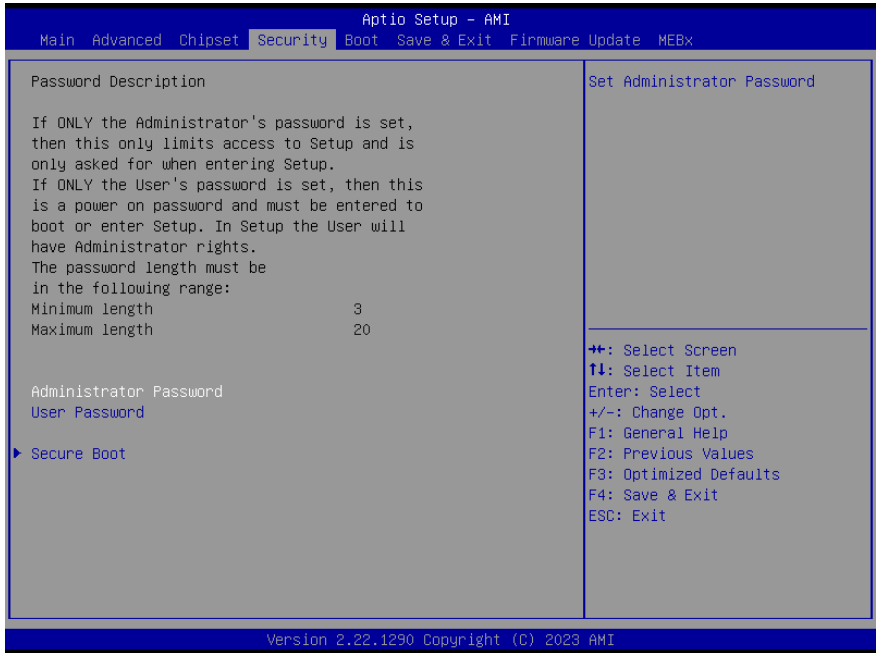

Change User/Supervisor Password

You can install a Supervisor password, and if you install a supervisor password, you can then install a user password. A user password does not provide access to many of the features in the Setup utility.

If you highlight these items and press Enter, a dialog box appears which lets you enter a password. You can enter no more than six letters or numbers. Press Enter after you have typed in the password. A second dialog box asks you to retype the password for confirmation. Press Enter after you have retyped it correctly. The password is required at boot time, or when the user enters the Setup utility.

Removing the Password

Highlight this item and type in the current password. At the next dialog box press Enter to disable password protection.

3.6.1 Secure Boot

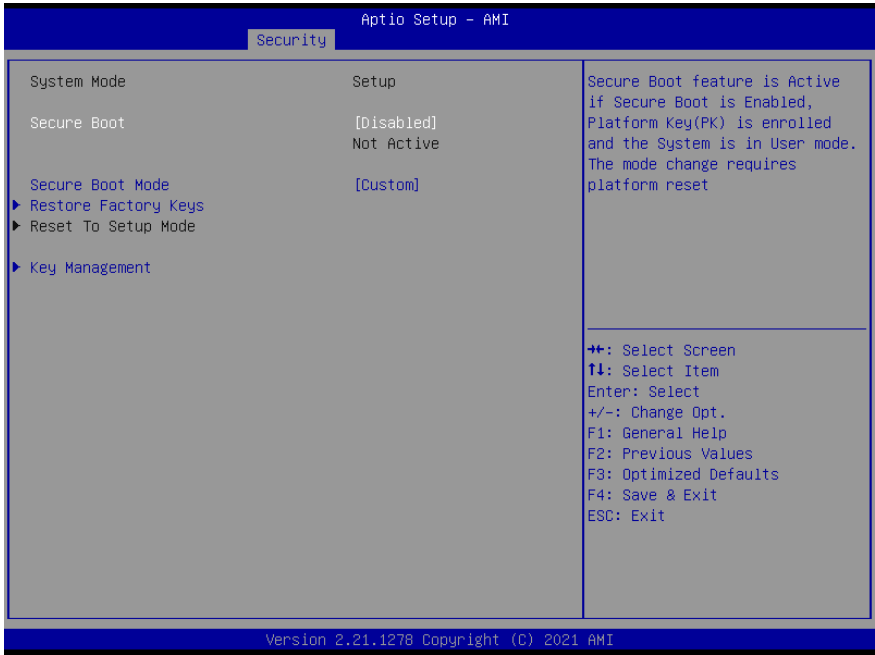

Options Summary		
Secure Boot	Disabled	Optimal Default, Failsafe Default
	Enabled	
Secure Boot feature is Active if Secure Boot is Enabled, Platform Key (PK) is enrolled and the System is in User mode. The mode change requires platform reset.		
Secure Boot Mode	Custom	Optimal Default, Failsafe Default
	Standard	
Secure Boot mode options: Standard or Custom. In Custom mode, Secure Boot Policy variables can be configured by a physically present user without full authentication.		
Restore Factory Keys		
Force System to User Mode. Install factory default Secure Boot key databases		
Reset to Setup Mode		
Delete all Secure Boot key databases from NVRAM		

3.6.2 Key Management

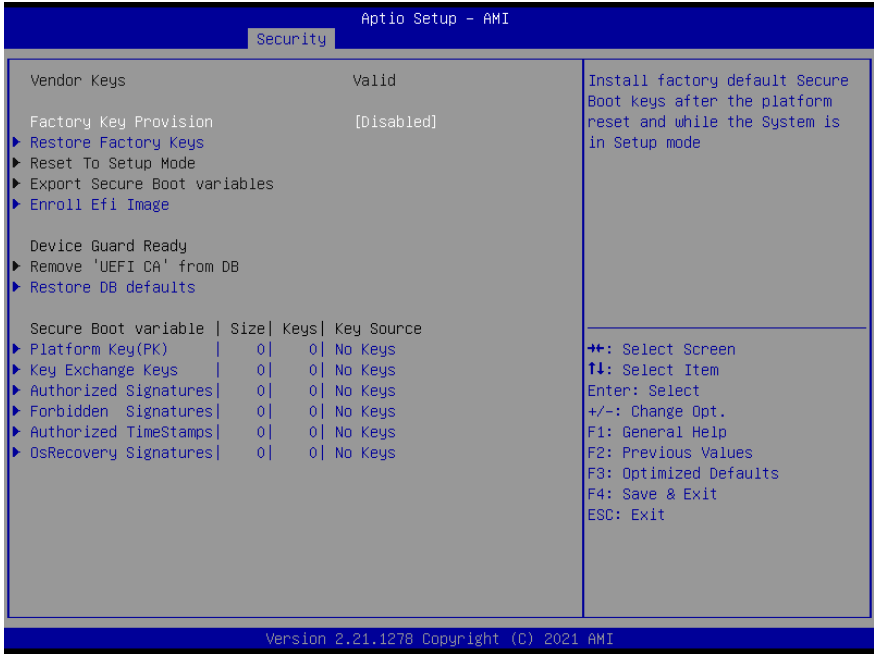

Options Summary		
Factory Key Provision	Disabled	Optimal Default, Failsafe Default
	Enabled	
Secure Boot feature is Active if Secure Boot is Enabled, Platform Key (PK) is enrolled and the System is in User mode. The mode change requires platform reset.		
Restore Factory Keys		
Force System to User Mode. Install factory default Secure Boot key databases.		
Reset to Setup Mode		
Delete all Secure Boot key databases from NVRAM.		
Export Secure Boot variables		
Copy NVRAM content of Secure Boot variables to files in a root folder on a file system device.		
Enroll Efi Image		
Allow the image to run in Secure Boot mode. Enroll SHA256 Hash certificate of a PE image into Authorized Signature Database (db).		
Remove 'UEFI CA' from DB		

Options Summary	
Device Guard ready system must not list 'Microsoft UEFI CA' Certificate in Authorized Signature database (db).	
Restore DB defaults	
Restore DB variable to factory defaults.	
Platform Key (PK)	Details
	Export
	Update
	Delete
Key Exchange Keys	Details
	Export
	Update
	Append
	Delete
Authorized Signatures	Details
	Export
	Update
	Append
	Delete
Forbidden Signatures	Details
	Export
	Update
	Append
	Delete
Authorized TimeStamps	Update
	Append
OsRecovery Signatures	Update
	Append
Enroll Factory Defaults or load certificates from a file: <ol style="list-style-type: none"> Public Key Certificate: <ol style="list-style-type: none"> EFI_SIGNATURE_LIST EFI_CERT_X509 (DER) EFI_CERT_RSA2048 (bin) EFI_CERT_SHAXXX Authenticated UEFI Variable EFI PE/COFF Image (SHA256) Key Source: Factory, External, Mixed.	

3.7 Setup Submenu: Boot



Options Summary		
Quiet Boot	Disabled	
	Enabled	Optimal Default, Failsafe Default
Enable or Disable Quiet Boot option.		
UEFI PXE Support	Disabled	Optimal Default, Failsafe Default
	Enabled	
Enable/Disable UEFI Network Stack.		
FIXED BOOT ORDER Priorities		
Sets the system boot order.		

3.7.1 BBS Priorities

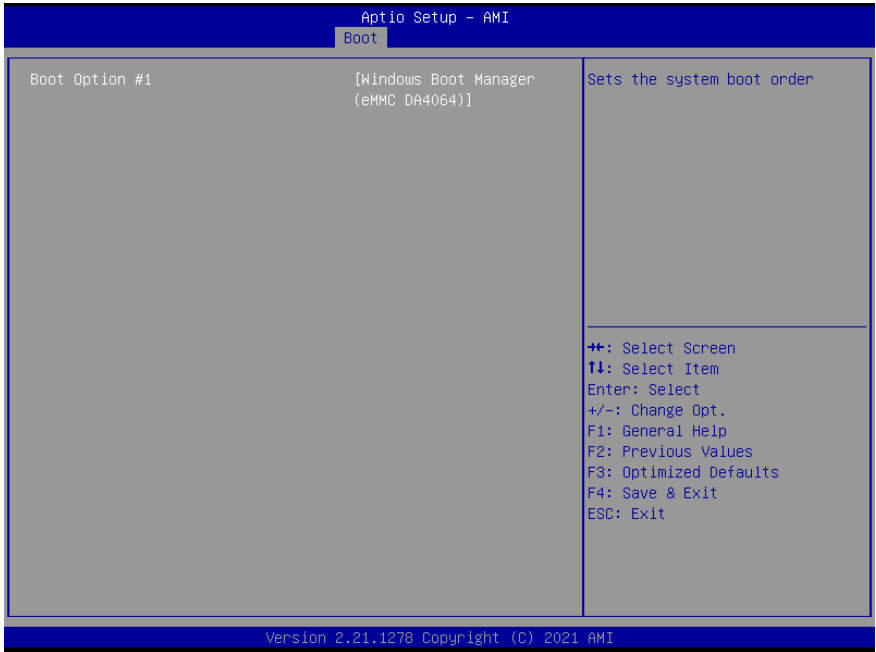

3.8 Setup Submenu: Save & Exit

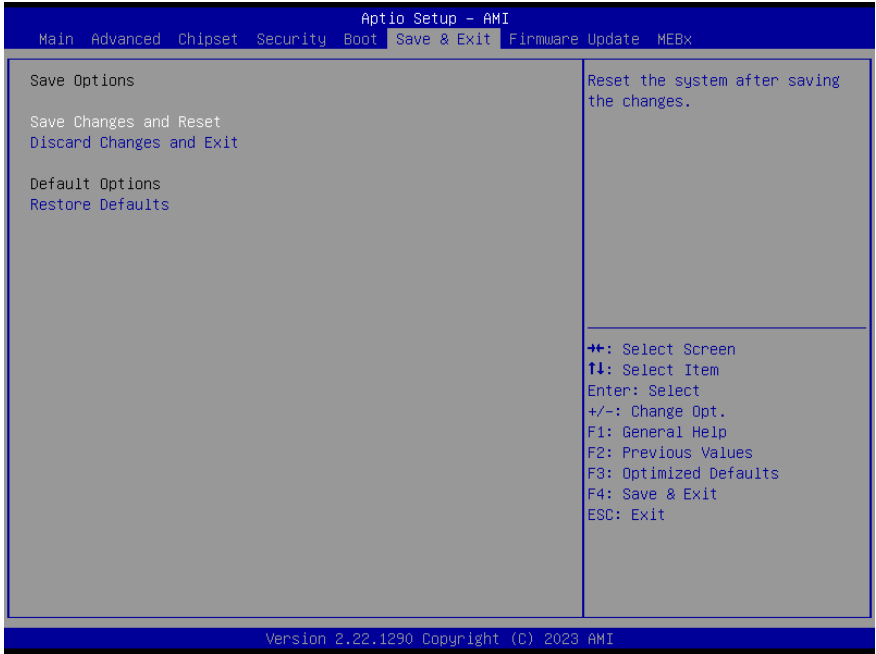

Options Summary	
Save Changes and Reset	Reset the system after saving the changes.
Discard Changes and Exit	Exit system setup without saving any changes.
Restore Defaults	Restore/Load Default values for all the setup options.

3.9 Setup Submenu: Firmware Update

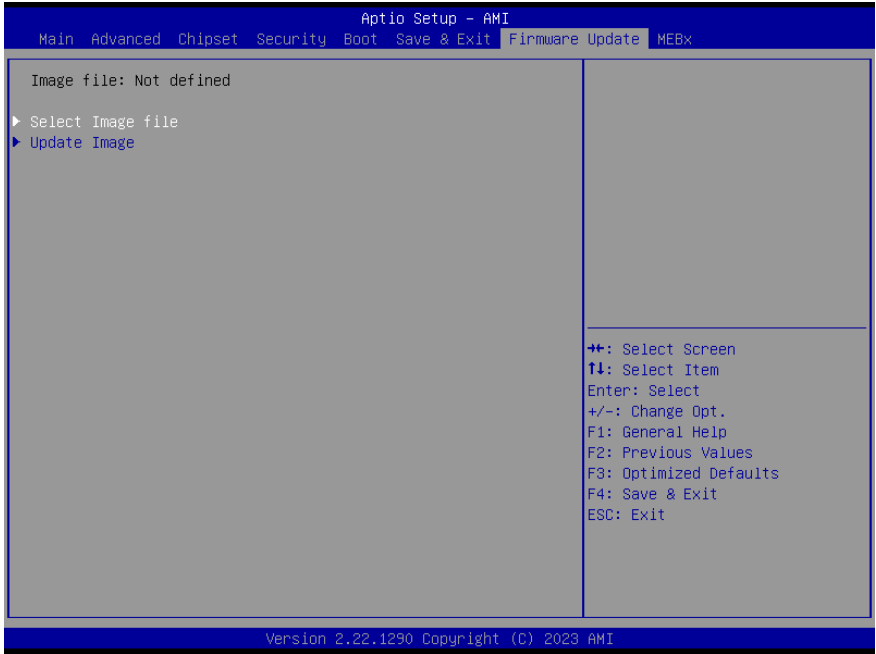

Options Summary	
Select Image file	Select Image file for Firmware Update.
Update Image	Update selected firmware file to update.

3.10 Setup Submenu: MEBx



3.10.1 Intel® AMT Configuration

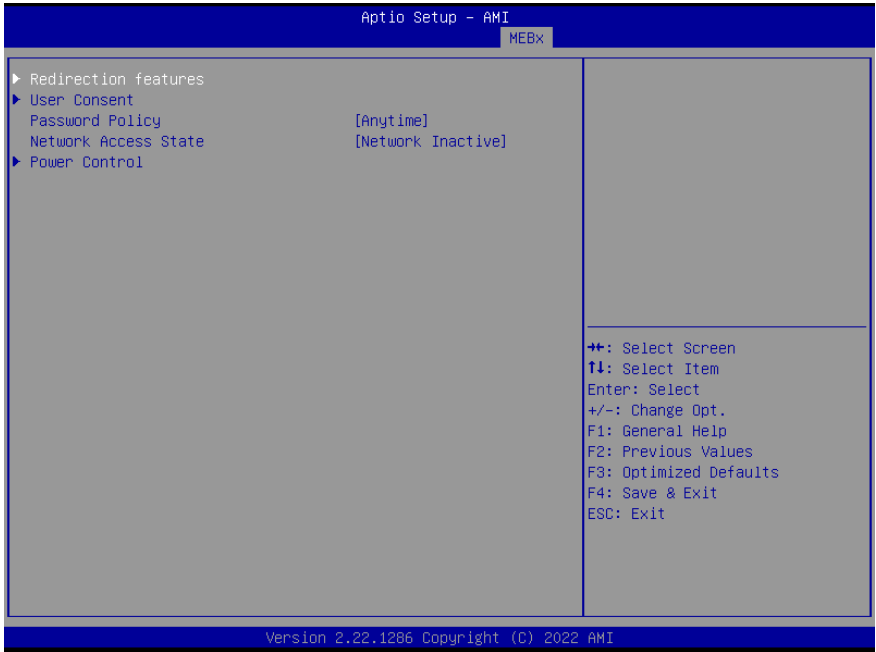

Options Summary

Password Policy	Default Password Only	
	During Setup and Configuration	
	Anytime	Optimal Default, Failsafe Default
Network Access State	Network Active	
	Network Inactive	Optimal Default, Failsafe Default
	Full Unprovision	
Changes network state of ME. When disabling, it will also clear some other settings.		

3.10.2 Redirection features

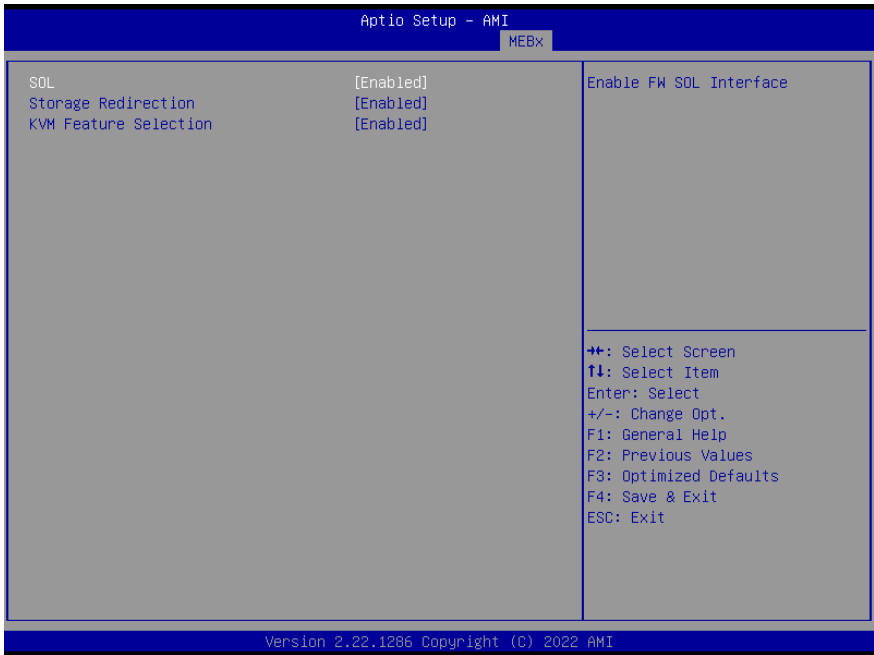

Options Summary		
SOL	Disabled	
	Enabled	Optimal Default, Failsafe Default
Enable FW SOL Interface.		
Storage Redirection	Disabled	
	Enabled	Optimal Default, Failsafe Default
Enable FW Remote – Storage Redirection.		
KVM Features Selection	Disabled	
	Enabled	Optimal Default, Failsafe Default
Enable FW KVM Feature.		

3.10.3 User Consent

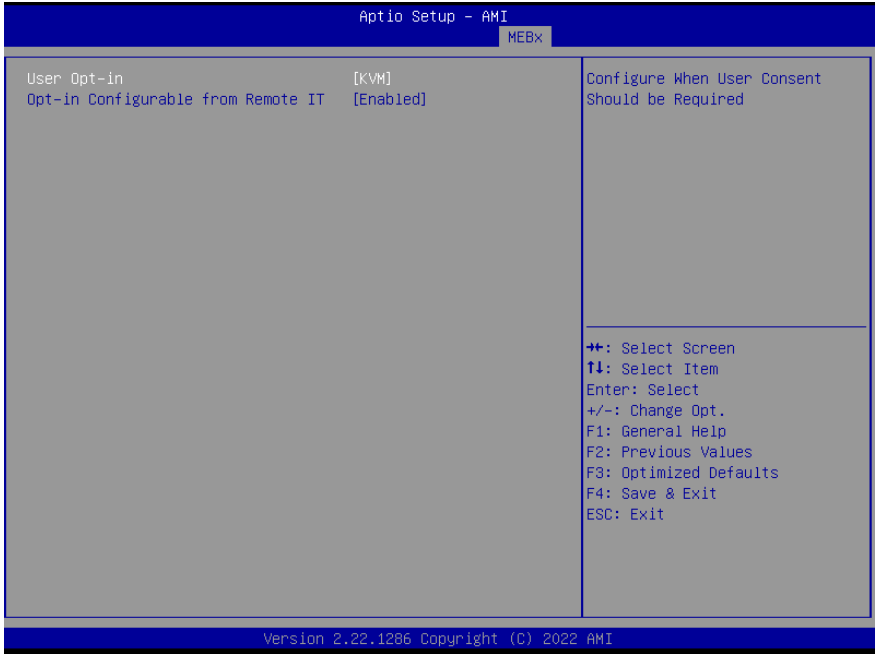

Options Summary		
User Opt-in	None	
	KVM	Optimal Default, Failsafe Default
	ALL	
Configure When User Consent Should be Required.		
Opt-in Configurable from Remote IT	Disabled	
	Enabled	Optimal Default, Failsafe Default
Enable/Disable Remote Change Capability of User Consent Feature.		

3.10.4 Power Control

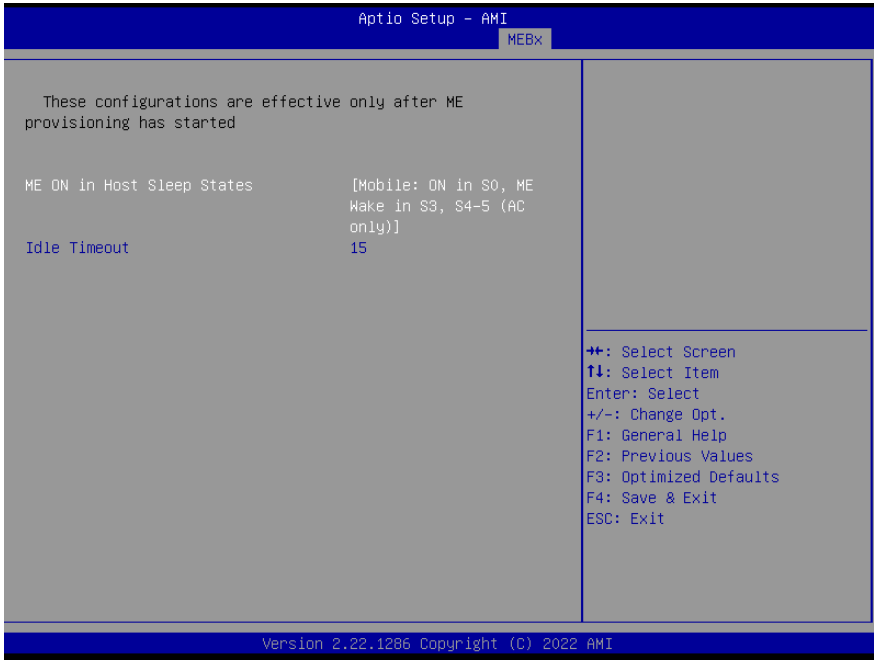

Options Summary		
ME ON in Host Sleep States	Mobile: ON in S0	Optimal Default, Failsafe Default
	Mobile: ON in S0, ME Wake in S3, S4-5(AC only)	
Idle Timeout	15	
Timeout Value (1-65536).		

Chapter 4

Driver Installation

4.1 Driver Download/Installation

Drivers for the PICO-RAP4 can be downloaded from the product page on the AAEON website by following this link:

<https://www.aaeon.com/en/p/pico-itx-boards-pico-rap4>

Download the driver(s) you need and follow the steps below to install them.

Chipset Driver

1. Open the folder where you unzipped the **Chipset Drivers**.
2. Run the **SetupChipset.exe** file in the folder.
3. Follow the instructions.
4. Drivers will be installed automatically.

Graphics Driver

1. Open the folder where you unzipped the **Graphics Drivers**.
2. Run the **gfx_win_101.4502.exe** file in the folder.
3. Follow the instructions.
4. Drivers will be installed automatically.

LAN Drivers (Windows 10)

1. Open the folder where you unzipped the **LAN Drivers**.
2. Run the **Autorun.exe** file in the folder.
3. Follow the instructions.
4. Drivers will be installed automatically.

Install Audio Drivers

Note: Ensure Intel Smart Sound Driver (**RPL_v10.29.00.8102**) is installed before the Realtek Audio driver (**Realtek Audio 6.0.9034.2**)

Install Intel Smart Sound Driver

1. Open the **Audio Drivers** folder and unzip the **Intel_SST_RPL_v10.29.00.8102** folder.
2. Install BUS driver (**IntcAudioBus.inf**) from the subfolder Drivers over **High-Definition Audio Controller** or **Multimedia Audio Controller** in the Device Manager.

Name of the device before installing driver: **High-Definition Audio Controller** or **Multimedia Audio Controller**.

Name of the device after installing the driver: **Intel® Smart Sound Technology (Intel® SST) Audio Controller** or **Intel® Smart Sound Technology BUS**.

3. Install OED driver (**IntcOED.inf**) from the subfolder **Drivers over Intel High-Definition DSP** in the **Device Manager**.

Name of the device before installing driver: **Intel High-Definition DSP**.

Name of the device after installing the driver: **Intel® Smart Sound Technology (Intel® SST) OED**.

Install Realtek Audio Driver

1. Open the **Intel Smart Sound Driver (Realtek Audio 6.0.9034.2)** folder
2. Run the **Setup.exe** file in the folder
3. Follow the instructions
4. Driver will be installed automatically

ME & TXE Drivers (Windows 10)

1. Open the **ME & TXE Driver** folder.
2. Run the **SetupME.exe** file in the folder.
3. Follow the instructions.
4. Drivers will be installed automatically.

Serial IO Driver

1. Open the **Peripheral Driver** folder.
2. Run the **SetupSerialIO.exe** file in the folder.
3. Follow the instructions.
4. Drivers will be installed automatically.

Linux Peripheral Drivers

1. Open the **Linux Driver-Peripheral** folder.
2. Follow the instructions provided in the **aaeon_wmi_all_V2.6.0.3.zip**. If you have any questions about the supported functions, please contact your regional FAE for more details.

Appendix A

Mating Connectors

A.1 List of Mating Connectors and Cables

The following table lists mating connectors and available cables.

Label	Function	Mating Connector		Available Cable	AAEON Cable P/N
		Vendor	Model no		
CN1	SATA Power	Molex	51021-0200	SATA Power Cable	170X000322
CN2	SATA	Molex	887505318	SATA Cable	1709070500
CN3	DC Jack Power Input	HUANG JI	5525C257-3T00-R1-7.5	Power Cable	1702041004
CN4	Front Panel	ACES	50247-010H0H0-001	Front Panel Cable	1709100108
CN7	LVDS Back Light Inverter	JST	SHR-06V-S-B	LVDS Inverter Cable	170X000152
CN9	Audio	ACES	50247-012H0H0-001	Audio cable	170X000156
CN11	4-pin Smart FAN	Molex	51021-0400	N/A	N/A
CN14	GPIO	ACES	50247-010H0H0-001	N/A	N/A
CN15 / CN18	COM Header	JST	SHR-09V-S-B	COM Port Cable	1701090122
CN17	LVDS	I-PEX	20453-040T-11	LVDS Cable	170X000532
	EDP			EDP Cable	170X000531
CN22	eSPI debug Header	JST	SHR-12V-S-B	eSPI debug Cable	1703120130
CN24	RTC Battery	Molex	51021-0200	Battery Cable	175011301K
CN36	Power Input	Molex	19211-0003	Power Cable	170204010R
CN38	USB2.0 Header	ACES	50247-010H0H0-001	USB Wafer Cable	170010010D

Appendix B

I/O Information

B.1 I/O Address Map

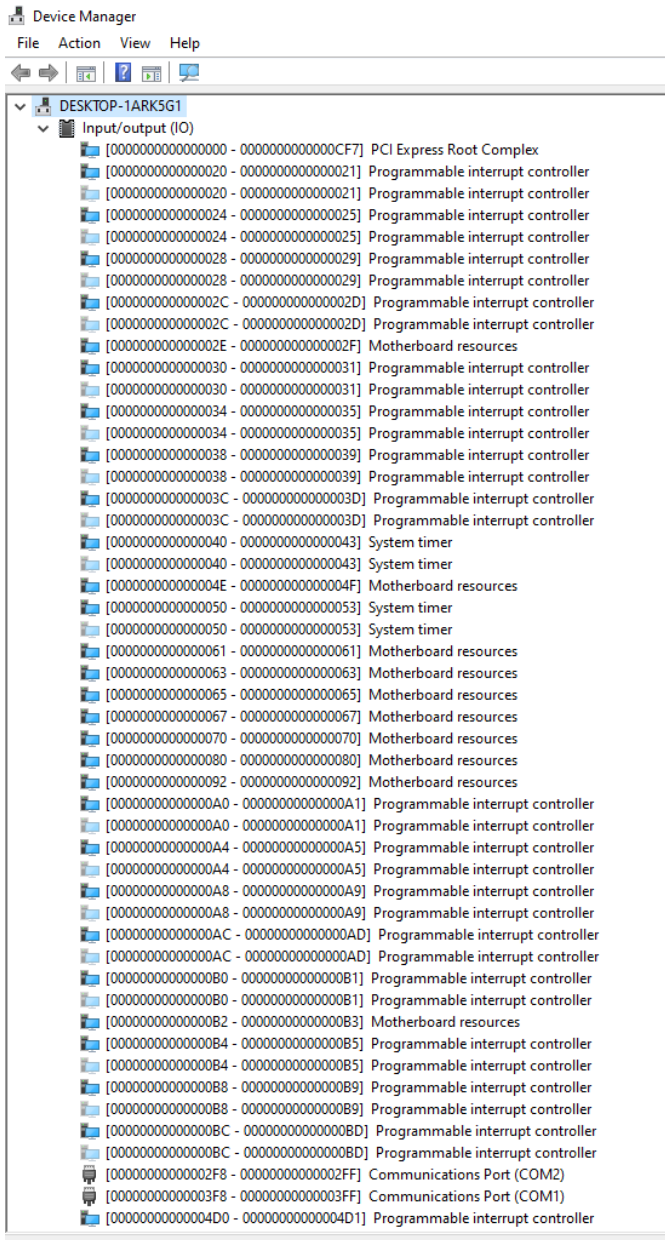

Device Manager

File Action View Help

	[0000000000000061 - 0000000000000061]	Motherboard resources
	[0000000000000063 - 0000000000000063]	Motherboard resources
	[0000000000000065 - 0000000000000065]	Motherboard resources
	[0000000000000067 - 0000000000000067]	Motherboard resources
	[0000000000000070 - 0000000000000070]	Motherboard resources
	[0000000000000080 - 0000000000000080]	Motherboard resources
	[0000000000000092 - 0000000000000092]	Motherboard resources
	[0000000000000A0 - 0000000000000A1]	Programmable interrupt controller
	[0000000000000A0 - 0000000000000A1]	Programmable interrupt controller
	[0000000000000A4 - 0000000000000A5]	Programmable interrupt controller
	[0000000000000A4 - 0000000000000A5]	Programmable interrupt controller
	[0000000000000A8 - 0000000000000A9]	Programmable interrupt controller
	[0000000000000A8 - 0000000000000A9]	Programmable interrupt controller
	[0000000000000A0 - 0000000000000AD]	Programmable interrupt controller
	[0000000000000AC - 0000000000000AD]	Programmable interrupt controller
	[0000000000000B0 - 0000000000000B1]	Programmable interrupt controller
	[0000000000000B0 - 0000000000000B1]	Programmable interrupt controller
	[0000000000000B2 - 0000000000000B3]	Motherboard resources
	[0000000000000B4 - 0000000000000B5]	Programmable interrupt controller
	[0000000000000B4 - 0000000000000B5]	Programmable interrupt controller
	[0000000000000B8 - 0000000000000B9]	Programmable interrupt controller
	[0000000000000B8 - 0000000000000B9]	Programmable interrupt controller
	[0000000000000BC - 0000000000000BD]	Programmable interrupt controller
	[0000000000000BC - 0000000000000BD]	Programmable interrupt controller
	[00000000000002F8 - 00000000000002FF]	Communications Port (COM2)
	[00000000000003F8 - 00000000000003FF]	Communications Port (COM1)
	[00000000000004D0 - 00000000000004D1]	Programmable interrupt controller
	[00000000000004D0 - 00000000000004D1]	Programmable interrupt controller
	[0000000000000680 - 000000000000069F]	Motherboard resources
	[0000000000000A00 - 0000000000000ADF]	Motherboard resources
	[0000000000000A10 - 0000000000000A1F]	Motherboard resources
	[0000000000000A20 - 0000000000000A2F]	Motherboard resources
	[0000000000000D00 - 0000000000000FFF]	PCI Express Root Complex
	[000000000000164E - 000000000000164F]	Motherboard resources
	[0000000000001854 - 000000000000185F]	Motherboard resources
	[0000000000001854 - 000000000000185F]	Motherboard resources
	[0000000000002000 - 00000000000020FF]	Motherboard resources
	[0000000000003000 - 000000000000303F]	Intel(R) UHD Graphics
	[0000000000003000 - 00000000000030FF]	PCI-to-PCI Bridge
	[0000000000003060 - 000000000000307F]	Standard SATA AHCI Controller
	[0000000000003080 - 0000000000003083]	Standard SATA AHCI Controller
	[0000000000003090 - 0000000000003097]	Standard SATA AHCI Controller
	[0000000000004000 - 000000000000403F]	Intel(R) UHD Graphics 770
	[0000000000004060 - 000000000000407F]	Standard SATA AHCI Controller
	[0000000000004080 - 0000000000004083]	Standard SATA AHCI Controller
	[0000000000004090 - 0000000000004097]	Standard SATA AHCI Controller
	[000000000000EFA0 - 000000000000EFBF]	Intel(R) SMBus - 51A3
	[000000000000EFA0 - 000000000000EFBF]	SM Bus Controller
	[000000000000FF8 - 000000000000FFFF]	Intel(R) Active Management Technology - SOL (COM3)
>		Interrupt request (IRQ)
>		Large Memory
>		Memory

B.2 IRQ Mapping Chart

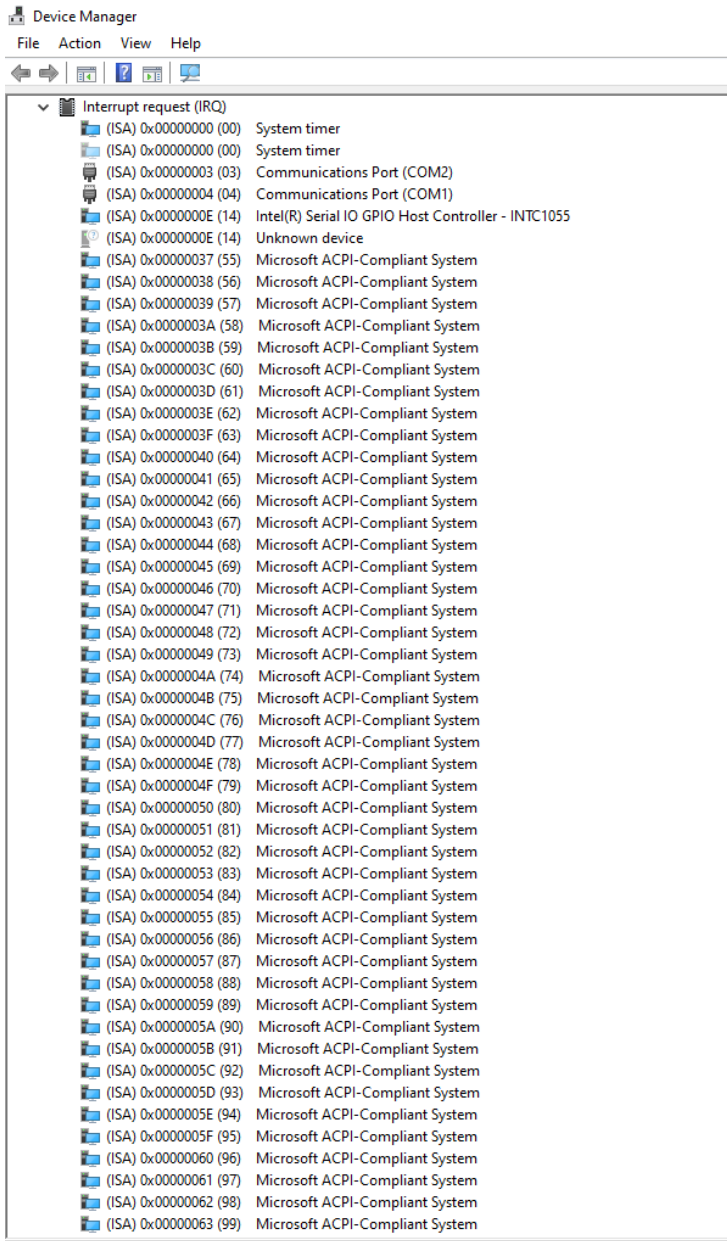

The screenshot displays the Windows Device Manager window, specifically the 'Interrupt request (IRQ)' section. The window title is 'Device Manager' and it includes a menu bar with 'File', 'Action', 'View', and 'Help'. Below the menu bar are navigation icons for back, forward, and search. The main content area shows a tree view under 'Interrupt request (IRQ)' with a list of devices and their corresponding IRQ numbers. The devices are listed in ascending order of their IRQ numbers, starting from 00 and ending at 99. Most devices are identified as 'Microsoft ACPI-Compliant System', while a few are specifically named: 'System timer', 'Communications Port (COM2)', 'Communications Port (COM1)', and 'Intel(R) Serial IO GPIO Host Controller - INTC1055'. There is also one entry for an 'Unknown device'.

Device Name	IRQ
System timer	00
System timer	00
Communications Port (COM2)	03
Communications Port (COM1)	04
Intel(R) Serial IO GPIO Host Controller - INTC1055	14
Unknown device	14
Microsoft ACPI-Compliant System	55
Microsoft ACPI-Compliant System	56
Microsoft ACPI-Compliant System	57
Microsoft ACPI-Compliant System	58
Microsoft ACPI-Compliant System	59
Microsoft ACPI-Compliant System	60
Microsoft ACPI-Compliant System	61
Microsoft ACPI-Compliant System	62
Microsoft ACPI-Compliant System	63
Microsoft ACPI-Compliant System	64
Microsoft ACPI-Compliant System	65
Microsoft ACPI-Compliant System	66
Microsoft ACPI-Compliant System	67
Microsoft ACPI-Compliant System	68
Microsoft ACPI-Compliant System	69
Microsoft ACPI-Compliant System	70
Microsoft ACPI-Compliant System	71
Microsoft ACPI-Compliant System	72
Microsoft ACPI-Compliant System	73
Microsoft ACPI-Compliant System	74
Microsoft ACPI-Compliant System	75
Microsoft ACPI-Compliant System	76
Microsoft ACPI-Compliant System	77
Microsoft ACPI-Compliant System	78
Microsoft ACPI-Compliant System	79
Microsoft ACPI-Compliant System	80
Microsoft ACPI-Compliant System	81
Microsoft ACPI-Compliant System	82
Microsoft ACPI-Compliant System	83
Microsoft ACPI-Compliant System	84
Microsoft ACPI-Compliant System	85
Microsoft ACPI-Compliant System	86
Microsoft ACPI-Compliant System	87
Microsoft ACPI-Compliant System	88
Microsoft ACPI-Compliant System	89
Microsoft ACPI-Compliant System	90
Microsoft ACPI-Compliant System	91
Microsoft ACPI-Compliant System	92
Microsoft ACPI-Compliant System	93
Microsoft ACPI-Compliant System	94
Microsoft ACPI-Compliant System	95
Microsoft ACPI-Compliant System	96
Microsoft ACPI-Compliant System	97
Microsoft ACPI-Compliant System	98
Microsoft ACPI-Compliant System	99

Device Manager

File Action View Help

← → [Refresh] [Help] [Details]

Microsoft ACPI-Compliant System	(ISA) 0x000001E2 (482)
Microsoft ACPI-Compliant System	(ISA) 0x000001E3 (483)
Microsoft ACPI-Compliant System	(ISA) 0x000001E4 (484)
Microsoft ACPI-Compliant System	(ISA) 0x000001E5 (485)
Microsoft ACPI-Compliant System	(ISA) 0x000001E6 (486)
Microsoft ACPI-Compliant System	(ISA) 0x000001E7 (487)
Microsoft ACPI-Compliant System	(ISA) 0x000001E8 (488)
Microsoft ACPI-Compliant System	(ISA) 0x000001E9 (489)
Microsoft ACPI-Compliant System	(ISA) 0x000001EA (490)
Microsoft ACPI-Compliant System	(ISA) 0x000001EB (491)
Microsoft ACPI-Compliant System	(ISA) 0x000001EC (492)
Microsoft ACPI-Compliant System	(ISA) 0x000001ED (493)
Microsoft ACPI-Compliant System	(ISA) 0x000001EE (494)
Microsoft ACPI-Compliant System	(ISA) 0x000001EF (495)
Microsoft ACPI-Compliant System	(ISA) 0x000001F0 (496)
Microsoft ACPI-Compliant System	(ISA) 0x000001F1 (497)
Microsoft ACPI-Compliant System	(ISA) 0x000001F2 (498)
Microsoft ACPI-Compliant System	(ISA) 0x000001F3 (499)
Microsoft ACPI-Compliant System	(ISA) 0x000001F4 (500)
Microsoft ACPI-Compliant System	(ISA) 0x000001F5 (501)
Microsoft ACPI-Compliant System	(ISA) 0x000001F6 (502)
Microsoft ACPI-Compliant System	(ISA) 0x000001F7 (503)
Microsoft ACPI-Compliant System	(ISA) 0x000001F8 (504)
Microsoft ACPI-Compliant System	(ISA) 0x000001F9 (505)
Microsoft ACPI-Compliant System	(ISA) 0x000001FA (506)
Microsoft ACPI-Compliant System	(ISA) 0x000001FB (507)
Microsoft ACPI-Compliant System	(ISA) 0x000001FC (508)
Microsoft ACPI-Compliant System	(ISA) 0x000001FD (509)
Microsoft ACPI-Compliant System	(ISA) 0x000001FE (510)
Microsoft ACPI-Compliant System	(ISA) 0x000001FF (511)
High Definition Audio Controller	(PCI) 0x00000010 (16)
Intel(R) Serial IO UART Host Controller - 51A8	(PCI) 0x00000010 (16)
Intel(R) Active Management Technology - SOL (COM3)	(PCI) 0x00000013 (19)
Intel(R) Serial IO I2C Host Controller - 51E8	(PCI) 0x0000001B (27)
Intel(R) Serial IO I2C Host Controller - 51EA	(PCI) 0x0000001D (29)
Intel(R) Serial IO I2C Host Controller - 51C5	(PCI) 0x0000001F (31)
Intel(R) Serial IO I2C Host Controller - 51C6	(PCI) 0x00000020 (32)
Intel(R) Serial IO SPI Host Controller - 51AB	(PCI) 0x00000025 (37)
Intel(R) Serial IO I2C Host Controller - 51E9	(PCI) 0x00000028 (40)
Intel(R) Management Engine Interface #1	(PCI) 0xFFFFFFF4 (-12)
Intel(R) Ethernet Controller I226-V	(PCI) 0xFFFFFFF5 (-11)
Intel(R) Ethernet Controller I226-V	(PCI) 0xFFFFFFF6 (-10)
Intel(R) Ethernet Controller I226-V	(PCI) 0xFFFFFFF7 (-9)
Intel(R) Ethernet Controller I226-V	(PCI) 0xFFFFFFF8 (-8)
Intel(R) Ethernet Controller I226-V	(PCI) 0xFFFFFFF9 (-7)
Intel(R) Ethernet Controller I226-V	(PCI) 0xFFFFFFFA (-6)
Intel(R) USB 3.10 eXtensible Host Controller - 1.20 (Microsoft)	(PCI) 0xFFFFFFFB (-5)
Intel(R) UHD Graphics	(PCI) 0xFFFFFFF4 (-4)
Intel(R) Ethernet Connection (16) I219-LM	(PCI) 0xFFFFFFF4 (-3)
Standard SATA AHCI Controller	(PCI) 0xFFFFFFF4 (-2)
> Large Memory	
> Memory	

B.3 Large Memory Map

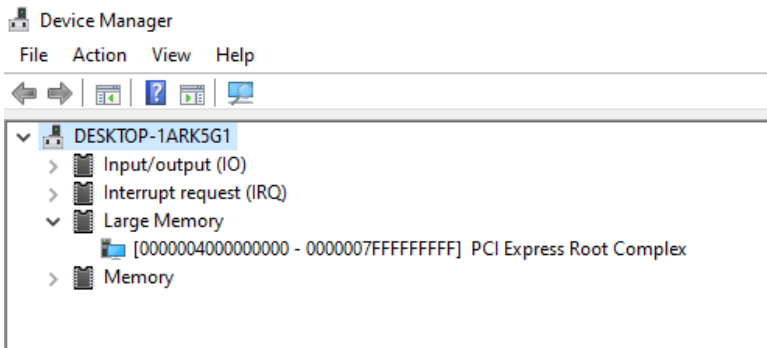

B.4 Memory Address Map

Device Manager

File Action View Help

Memory

- [0000000000A0000 - 0000000000BFFFF] PCI Express Root Complex
- [00000000050400000 - 000000000504FFFFF] Intel(R) Ethernet Controller I226-V
- [00000000050400000 - 000000000505FFFFF] Intel(R) PCI Express Root Port #8 - 51BF
- [00000000050400000 - 00000000050503FFF] PCI Express Root Complex
- [00000000050500000 - 00000000050503FFF] Intel(R) Ethernet Controller I226-V
- [00000000050600000 - 0000000005061FFFF] Intel(R) Ethernet Connection (16) I219-LM
- [00000000050622000 - 00000000050621FFF] Standard SATA AHCI Controller
- [00000000050622000 - 00000000050622FFF] Standard SATA AHCI Controller
- [00000000050623000 - 000000000506230FF] Standard SATA AHCI Controller
- [00000000080400000 - 00000000080DFFFFF] PCI-to-PCI Bridge
- [00000000080E00000 - 00000000080FFFFF] PCI-to-PCI Bridge
- [00000000081020000 - 00000000081021FFF] Standard SATA AHCI Controller
- [00000000081022000 - 000000000810227FF] Standard SATA AHCI Controller
- [00000000081023000 - 000000000810230FF] Standard SATA AHCI Controller
- [00000000BFFFF0000 - 00000000BFFFFFFF] Intel(R) Active Management Technology - SOL (COM3)
- [00000000C00000000 - 00000000C0FFFFFFF] Motherboard resources
- [00000000E06900000 - 00000000E069FFFFF] Unknown device
- [00000000E06A00000 - 00000000E06AFFFFF] Unknown device
- [00000000E06B00000 - 00000000E06BFFFFF] Unknown device
- [00000000E06D00000 - 00000000E06DFFFFF] Unknown device
- [00000000E06E00000 - 00000000E06EFFFFF] Unknown device
- [00000000FD6900000 - 00000000FD69FFFFF] Intel(R) Serial IO GPIO Host Controller - INTC1055
- [00000000FD6A00000 - 00000000FD6AFFFFF] Intel(R) Serial IO GPIO Host Controller - INTC1055
- [00000000FD6D00000 - 00000000FD6DFFFFF] Intel(R) Serial IO GPIO Host Controller - INTC1055
- [00000000FD6E00000 - 00000000FD6EFFFFF] Intel(R) Serial IO GPIO Host Controller - INTC1055
- [00000000FE0100000 - 00000000FE010FFFF] Intel(R) SPI (flash) Controller - 51A4
- [00000000FE0100000 - 00000000FE010FFFF] PCI Device
- [00000000FED000000 - 00000000FED003FFF] High precision event timer
- [00000000FED200000 - 00000000FED77FFFF] Motherboard resources
- [00000000FED400000 - 00000000FED44FFFF] Trusted Platform Module 2.0
- [00000000FED450000 - 00000000FED8FFFFF] Motherboard resources
- [00000000FED900000 - 00000000FED93FFFF] Motherboard resources
- [00000000FEDA00000 - 00000000FEDA0FFFF] Motherboard resources
- [00000000FEDA10000 - 00000000FEDA1FFFF] Motherboard resources
- [00000000FEDC00000 - 00000000FEDC7FFFF] Motherboard resources
- [00000000FEE000000 - 00000000FEEFFFFF] Motherboard resources
- [00000040000000000 - 00000040000000000] Intel(R) UHD Graphics
- [00000040000000000 - 00000040000000000] Intel(R) UHD Graphics 770
- [00000060000000000 - 00000060000000000] Intel(R) UHD Graphics
- [00000060000000000 - 00000060000000000] Intel(R) UHD Graphics 770
- [00000060011000000 - 0000006001100FFFF] Intel(R) USB 3.1 eXtensible Host Controller - 1.20 (Microsoft)
- [00000060011000000 - 0000006001100FFFF] Intel(R) USB 3.20 eXtensible Host Controller - 1.20 (Microsoft)
- [00000060011100000 - 0000006001117FFFF] Intel(R) Crashlog - A77D
- [00000060011180000 - 00000060011180FFF] SM Bus Controller
- [00000060011280000 - 00000060011280FFF] Intel(R) SMBus - 51A3
- [0000007FFFEF40000 - 0000007FFFEF44FFF] Intel(R) Serial IO UART Host Controller - 51A8
- [0000007FFFEF50000 - 0000007FFFEF55FFF] Intel(R) Serial IO I2C Host Controller - 51C6
- [0000007FFFEF60000 - 0000007FFFEF66FFF] Intel(R) Serial IO I2C Host Controller - 51C5
- [0000007FFFEF70000 - 0000007FFFEF77FFF] Intel(R) Management Engine Interface #1
- [0000007FFFEF80000 - 0000007FFFEF88FFF] Intel(R) Serial IO I2C Host Controller - 51EA

Device Manager

File Action View Help

< > [Refresh] [Help] [Log] [Details]

- > Large Memory
 - > Memory
 - [Icon] [0000000000A0000 - 00000000008BFFF] PCI Express Root Complex
 - [Icon] [000000005040000 - 00000000504FFFF] Intel(R) Ethernet Controller I226-V
 - [Icon] [000000005040000 - 00000000505FFFF] Intel(R) PCI Express Root Port #8 - 51BF
 - [Icon] [000000005040000 - 00000000BFFFFFF] PCI Express Root Complex
 - [Icon] [000000005050000 - 0000000050503FF] Intel(R) Ethernet Controller I226-V
 - [Icon] [000000005060000 - 000000005061FFF] Intel(R) Ethernet Connection (16) I219-LM
 - [Icon] [000000005062000 - 0000000050621FF] Standard SATA AHCI Controller
 - [Icon] [000000005062200 - 00000000506227FF] Standard SATA AHCI Controller
 - [Icon] [000000005062300 - 00000000506230FF] Standard SATA AHCI Controller
 - [Icon] [000000008040000 - 0000000080DFFFF] PCI-to-PCI Bridge
 - [Icon] [0000000080E0000 - 0000000080BFFFF] PCI-to-PCI Bridge
 - [Icon] [000000008102000 - 0000000081021FF] Standard SATA AHCI Controller
 - [Icon] [000000008102200 - 00000000810227FF] Standard SATA AHCI Controller
 - [Icon] [000000008102300 - 00000000810230FF] Standard SATA AHCI Controller
 - [Icon] [00000000BFFF000 - 00000000BFFFFFF] Intel(R) Active Management Technology - SOL (COM3)
 - [Icon] [00000000C000000 - 00000000CFFFFFF] Motherboard resources
 - [Icon] [00000000E069000 - 00000000E069FFF] Unknown device
 - [Icon] [00000000E06A000 - 00000000E06AFFF] Unknown device
 - [Icon] [00000000E06B000 - 00000000E06BFFF] Unknown device
 - [Icon] [00000000E06D000 - 00000000E06DFFF] Unknown device
 - [Icon] [00000000E06E000 - 00000000E06EFFF] Unknown device
 - [Icon] [00000000FD690000 - 00000000FD69FFF] Intel(R) Serial IO GPIO Host Controller - INTC1055
 - [Icon] [00000000FD6A0000 - 00000000FD6AFFF] Intel(R) Serial IO GPIO Host Controller - INTC1055
 - [Icon] [00000000FD6D0000 - 00000000FD6DFFF] Intel(R) Serial IO GPIO Host Controller - INTC1055
 - [Icon] [00000000FD6E0000 - 00000000FD6EFFF] Intel(R) Serial IO GPIO Host Controller - INTC1055
 - [Icon] [00000000FE010000 - 00000000FE010FF] Intel(R) SPI (flash) Controller - 51A4
 - [Icon] [00000000FE010000 - 00000000FE010FF] PCI Device
 - [Icon] [00000000FED0000 - 00000000FED003FF] High precision event timer
 - [Icon] [00000000FED20000 - 00000000FED7FFF] Motherboard resources
 - [Icon] [00000000FED40000 - 00000000FED44FFF] Trusted Platform Module 2.0
 - [Icon] [00000000FED45000 - 00000000FED8FFF] Motherboard resources
 - [Icon] [00000000FED90000 - 00000000FED93FFF] Motherboard resources
 - [Icon] [00000000FEDA0000 - 00000000FEDA0FFF] Motherboard resources
 - [Icon] [00000000FEDA1000 - 00000000FEDA1FFF] Motherboard resources
 - [Icon] [00000000FEDC0000 - 00000000FEDC7FFF] Motherboard resources
 - [Icon] [00000000FEE00000 - 00000000FEE0FFF] Motherboard resources
 - [Icon] [0000004000000000 - 000000400FFFFFF] Intel(R) UHD Graphics
 - [Icon] [0000004000000000 - 000000400FFFFFF] Intel(R) UHD Graphics 770
 - [Icon] [0000006000000000 - 0000006000FFFFFF] Intel(R) UHD Graphics
 - [Icon] [0000006000000000 - 0000006000FFFFFF] Intel(R) UHD Graphics 770
 - [Icon] [0000006001100000 - 000000600110FFFF] Intel(R) USB 3.1o eXtensible Host Controller - 1.20 (Microsoft)
 - [Icon] [0000006001100000 - 000000600110FFFF] Intel(R) USB 3.2o eXtensible Host Controller - 1.20 (Microsoft)
 - [Icon] [0000006001110000 - 0000006001117FFF] Intel(R) Crashlog - A77D
 - [Icon] [0000006001118000 - 00000060011180FF] SM Bus Controller
 - [Icon] [0000006001128000 - 00000060011280FF] Intel(R) SMBus - 51A3
 - [Icon] [0000007FFFEF4000 - 0000007FFFEF4FFF] Intel(R) Serial IO UART Host Controller - 51A8
 - [Icon] [0000007FFFEF5000 - 0000007FFFEF55FF] Intel(R) Serial IO I2C Host Controller - 51C6
 - [Icon] [0000007FFFEF6000 - 0000007FFFEF65FF] Intel(R) Serial IO I2C Host Controller - 51C5
 - [Icon] [0000007FFFEF7000 - 0000007FFFEF75FF] Intel(R) Management Engine Interface #1
 - [Icon] [0000007FFFEF8000 - 0000007FFFEF85FF] Intel(R) Serial IO I2C Host Controller - 51EA