



HPC-RPSC

COM HPC Client

User's Manual 5th Ed

Copyright Notice

This document is copyrighted, 2026. All rights are reserved. The original manufacturer reserves the right to make improvements to the products described in this manual at any time without notice.

No part of this manual may be reproduced, copied, translated, or transmitted in any form or by any means without the prior written permission of the original manufacturer. Information provided in this manual is intended to be accurate and reliable. However, the original manufacturer assumes no responsibility for its use, or for any infringements upon the rights of third parties that may result from its use.

The material in this document is for product information only and is subject to change without notice. While reasonable efforts have been made in the preparation of this document to assure its accuracy, AAEMON assumes no liabilities resulting from errors or omissions in this document, or from the use of the information contained herein.

AAEMON reserves the right to make changes in the product design without notice to its users.

Acknowledgements

All other products' name or trademarks are properties of their respective owners.

- Microsoft Windows is a registered trademark of Microsoft Corp.
- Intel® is a registered trademark of Intel Corporation
- Core™ is a trademark of Intel Corporation
- IBM, PC/AT, PS/2, and VGA are trademarks of International Business Machines Corporation.
- Linux® is a registered trademark of Linus Torvalds in the United States and other countries

All other product names or trademarks are properties of their respective owners.

Omission from this list does not imply any claim of ownership by the publisher of this document.

Packing List

Before setting up your product, please make sure the following items have been shipped:

Item	Quantity
● HPC-RPSC	1

If any of these items are missing or damaged, please contact your distributor or sales representative immediately.

About this Document

This User's Manual contains all the essential information, such as detailed descriptions and explanations on the product's hardware and software features (if any), its specifications, dimensions, jumper/connector settings/definitions, and driver installation instructions (if any), to facilitate users in setting up their product.

Users may refer to the product page at AAEON.com for the latest version of this document.

Safety Precautions

Please read the following safety instructions carefully. It is advised that you keep this manual for future references

1. All cautions and warnings on the device should be noted.
2. Make sure the power source matches the power rating of the device.
3. Position the power cord so that people cannot step on it. Do not place anything over the power cord.
4. Always completely disconnect the power before working on the system's hardware.
5. No connections should be made when the system is powered as a sudden rush of power may damage sensitive electronic components.
6. If the device is not to be used for a long time, disconnect it from the power supply to avoid damage by transient over-voltage.
7. Always disconnect this device from any AC supply before cleaning.
8. While cleaning, use a damp cloth instead of liquid or spray detergents.
9. Make sure the device is installed near a power outlet and is easily accessible.
10. Keep this device away from humidity.
11. Place the device on a solid surface during installation to prevent falls
12. Do not cover the openings on the device to ensure optimal heat dissipation.
13. Watch out for high temperatures when the system is running.
14. Do not touch the heat sink or heat spreader when the system is running
15. Never pour any liquid into the openings. This could cause fire or electric shock.
16. As most electronic components are sensitive to static electrical charge, be sure to ground yourself to prevent static charge when installing the internal components. Use a grounding wrist strap and contain all electronic components in any static-shielded containers.

17. If any of the following situations arises, please the contact our service personnel:
 - i. Damaged power cord or plug
 - ii. Liquid intrusion to the device
 - iii. Exposure to moisture
 - iv. Device is not working as expected or in a manner as described in this manual
 - v. The device is dropped or damaged
 - vi. Any obvious signs of damage displayed on the device
18. **DO NOT LEAVE THIS DEVICE IN AN UNCONTROLLED ENVIRONMENT WITH TEMPERATURES BEYOND THE DEVICE'S PERMITTED STORAGE TEMPERATURES (SEE CHAPTER 1) TO PREVENT DAMAGE.**

Warning!



This device complies with Part 15 FCC Rules. Operation is subject to the following two conditions: (1) this device may not cause harmful interference, and (2) this device must accept any interference received including interference that may cause undesired operation.

Caution:

There is a danger of explosion if the battery is incorrectly replaced. Replace only with the same or equivalent type recommended by the manufacturer. Dispose of used batteries according to the manufacturer's instructions and your local government's recycling or disposal directives.

Attention:

Il y a un risque d'explosion si la batterie est remplacée de façon incorrecte. Ne la remplacer qu'avec le même modèle ou équivalent recommandé par le constructeur. Recycler les batteries usées en accord avec les instructions du fabricant et les directives gouvernementales de recyclage.

产品中有毒有害物质或元素名称及含量

AAEON 主板/子板/背板

QQ04-381 Rev.A2

部件名称	有毒有害物质或元素					
	铅 (Pb)	汞 (Hg)	镉 (Cd)	六价铬 (Cr(VI))	多溴联苯 (PBB)	多溴二苯醚 (PBDE)
印刷电路板 及其电子组件	×	○	○	○	○	○
外部信号 连接器及线材	×	○	○	○	○	○

本表格依据 SJ/T 11364 的规定编制。

○：表示该有毒有害物质在该部件所有均质材料中的含量均在GB/T 26572标准规定的限量要求以下。

×：表示该有害物质的某一均质材料超出了GB/T 26572的限量要求，然而该部件仍符合欧盟指令2011/65/EU 的规范。

环保使用期限(EFUP (Environmental Friendly Use Period))：10年

备注：此产品所标示之环保使用期限，系指在一般正常使用状况下。

China RoHS Requirement (EN)

Name and content of hazardous substances in product

AAEON Main Board/Daughter Board/Backplane

QO4-381 Rev.A2

Part Name	Hazardous Substances					
	铅 (Pb)	汞 (Hg)	镉 (Cd)	六价铬 (Cr(VI))	多溴联苯 (PBB)	多溴二苯醚 (PBDE)
PCB Assemblies	×	○	○	○	○	○
Connector and Cable	×	○	○	○	○	○

The table is prepared in accordance with the provisions of SJ/T 11364.

○: Indicates that said hazardous substance contained in all of the homogenous materials for this product is below the limit requirement of GB/T 26572.

×: Indicates that said hazardous substance contained in at least one of the homogenous materials used for this part is above the limit requirement of GB/T 26572. But this product still be compliance with 2011/65/EU Directive (allowed with 2011/65/EU Annex III of RoHS exemption with number 6(c),7(a),7(c)-1).

EFUP (Environment Friendly Use Period) value: 10 years

Notes: This product defined period of use is under normal condition.

Table of Contents

Chapter 1 - Product Specifications	1
1.1 Specifications	2
1.2 Block Diagram	4
Chapter 2 – Hardware Information	5
2.1 Dimensions	6
2.2 Jumpers and Connectors.....	8
2.3 List of Connectors.....	10
2.3.1 Row A/B/C/D Connector (J1).....	10
2.3.2 Row E/F/G/H Connector (J2).....	14
2.3.3 LPC (LPC1)	17
2.3.4 Battery (JRTC1).....	18
2.3.5 M.2 2280 M-Key (M2).....	18
Chapter 3 - AMI BIOS Setup	21
3.1 System Test and Initialization	22
3.2 AMI BIOS Setup	23
3.3 Setup Submenu: Main.....	24
3.4 Setup Submenu: Advanced.....	25
3.4.1 Graphics Configuration	26
3.4.2 CPU Configuration	27
3.4.2.1 Efficient-Core Information	28
3.4.2.2 Performance-Core Information	29
3.4.2.3 View/Configure Turbo Options.....	30
3.4.2.4 Custom P-state Table.....	31
3.4.3 Memory Configuration.....	32
3.4.4 On-Module H/W Monitor.....	33
3.4.4.1 Smart Fan Mode Configuration.....	34

3.4.5	PCH-FW Configuration.....	37
3.4.5.1	Firmware Update Configuration.....	38
3.4.6	On-Module Configuration.....	39
3.4.7	Power Management.....	40
3.4.8	AAEON BIOS Robot.....	41
3.4.9	AAEON Smart Boost.....	43
3.5	Setup Submenu: System I/O.....	47
3.5.1	PCI Express Configuration.....	48
3.5.2	Storage Configuration.....	58
3.5.3	VMD Setup Menu.....	59
3.5.4	NMVe Configuration.....	60
3.5.5	SATA Configuration.....	61
3.5.6	HD Audio Configuration.....	62
3.5.7	Digital IO Port Configuration.....	63
3.5.8	Legacy Logical Devices Configuration.....	64
3.5.8.1	Serial Port 1 Configuration.....	65
3.5.8.2	Serial Port 2 Configuration.....	66
3.5.9	Serial Port Console Redirection.....	67
3.6	Setup Submenu: Security.....	68
3.6.1	Secure Boot.....	69
3.6.1.1	Key Management.....	70
3.6.2	Trusted Computing.....	71
3.7	Setup Submenu: Boot.....	73
3.8	Setup Submenu: Save & Exit.....	74
Chapter 4 – Drivers Installation.....		75
4.1	Drivers Download and Installation.....	76
Appendix A - I/O Information.....		78
A.1	I/O Address Map.....	79

A.2	Memory Address Map	80
A.3	Large Memory Address Map	81
A.4	IRQ Mapping Chart.....	82

Chapter 1

Product Specifications

1.1 Specifications

System

Form Factor	COM HPC Client Size C
CPU	12th/13th/14th Gen Intel® Core™ Processors Intel® Core™ processors (Series 2)
Chipset	Intel® R680E Chipset
Memory	DDR5 5600MHz, Dual Channel SODIMM x 2, up to 64GB (ECC)
Onboard Storage	—
BIOS	AMI UEFI
Wake on LAN	Yes
Watchdog Timer	255 Levels
Dimension	6.30" x 4.72" (160mm x 120mm)
Security	TPM 2.0

Power

Power Requirement	+12V and +5VSB for ATX, +12V for AT
Power Type	AT/ATX
Power Consumption (Typical)	Intel® Core™ i9-13900E, 7.13A @+12V

Display

Graphics Controller	Intel® UHD Graphics 770
Video Output	4 Simultaneous Displays: eDP x 1, up to 3840 x 2160 @60Hz DDI x 3, up to 3840 x 2160 @144Hz

I/O

Ethernet	Intel® Ethernet Controller I226-LM 2.5GbE x 2
Audio	High Definition Audio Interface
USB Port	USB 2.0 x 8 USB 3.2 Type-C x 2 (20Gbps x 2) USB 3.2 Type-A x 4 (10Gbps)
Serial Port	4-Wire UART x 2 (Tx/Rx)
HDD Interface	SATA 6Gb/s x 2
Expansion	PEG 5.0 [x16] x 1 PCIe 4.0 [x4] x 3 PCIe 3.0 [x1] x 8 eSPI x 1 LPC x 1 M.2 2280 M-Key x 1
GPIO	12-bit
SMBus/I2C	I2C x 2 SMBus x 1

Environmental

Operating Temperature	32°F – 140°F (0°C – 60°C)
Storage Temperature	-40°F – 185°F (-40°C – 85°C)
Operating Humidity	0% – 90% relative humidity, non-condensing
EMC	CE/FCC Class A
OS Support	Windows® 10 (64-bit) Linux Ubuntu 20.04.1/Kernel 5.15
Weight	0.66 lb (0.30 kg)

1.2 Block Diagram

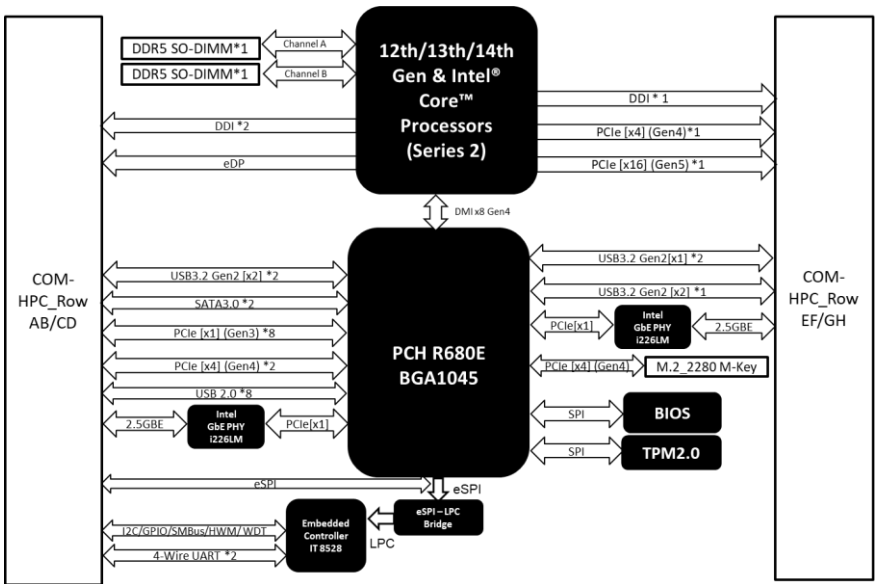

Chapter 2

Hardware Information

2.1 Dimensions

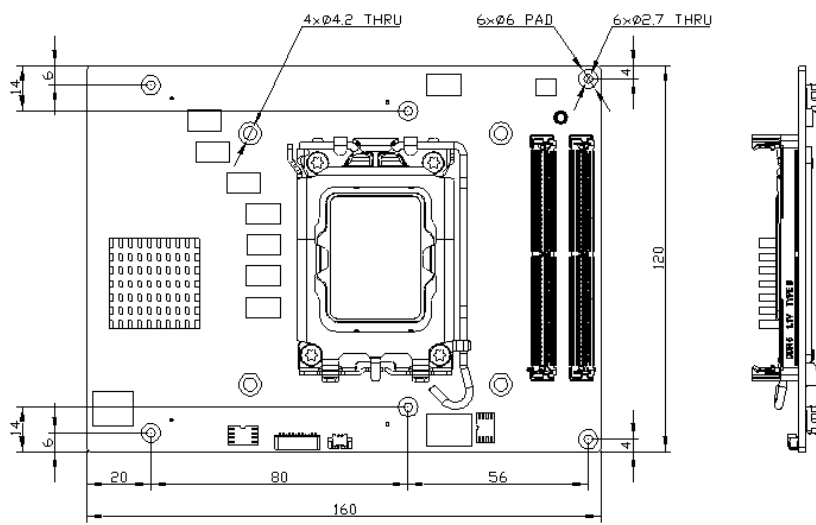

Top Side

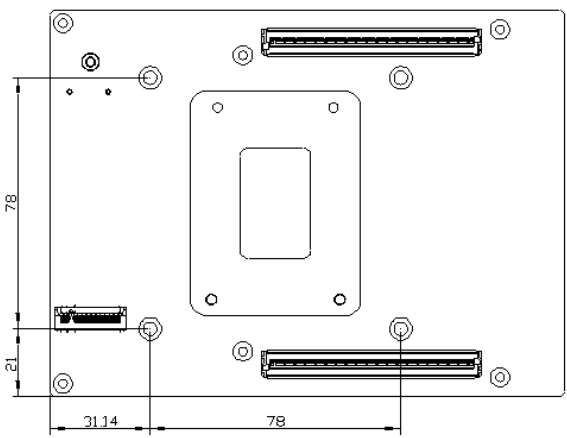
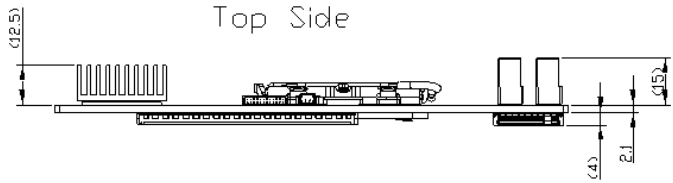

Bottom Side

With Active Cooler (P/N HPC-RPSC-FAN01)

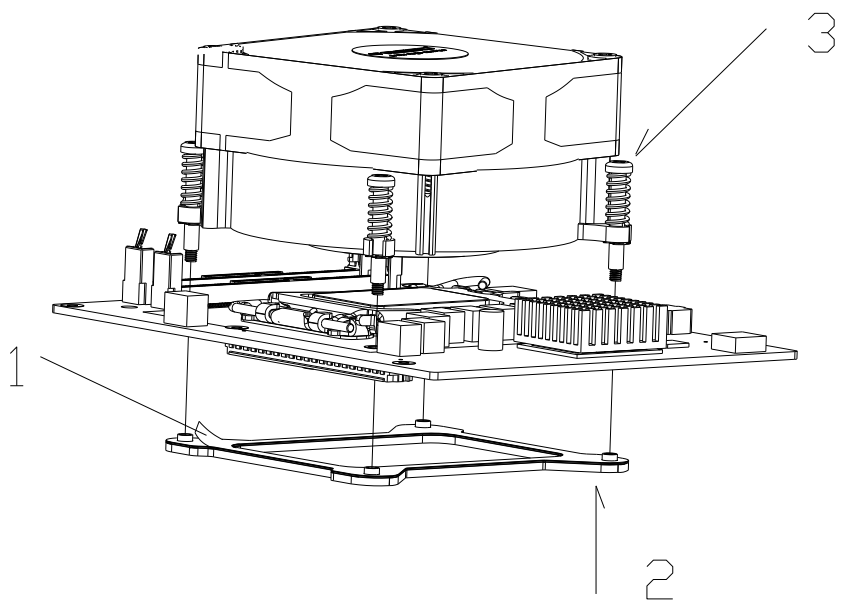
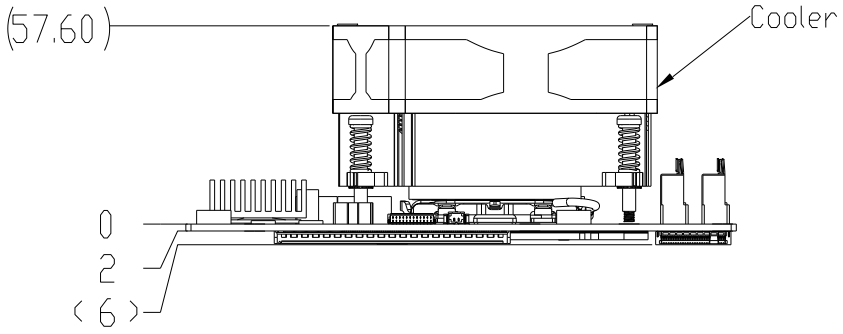

2.2 Jumpers and Connectors

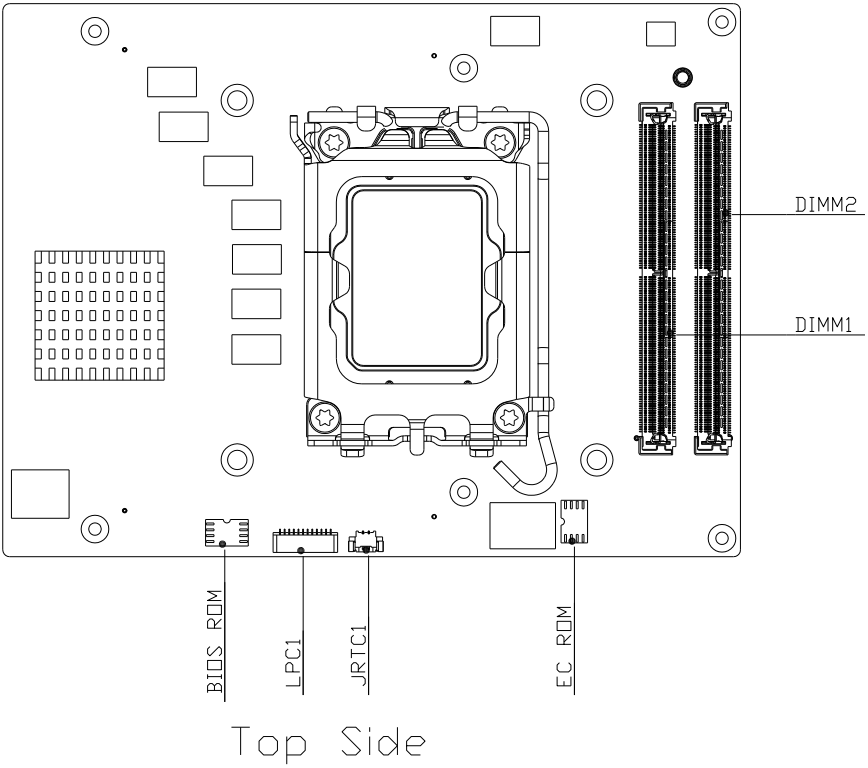

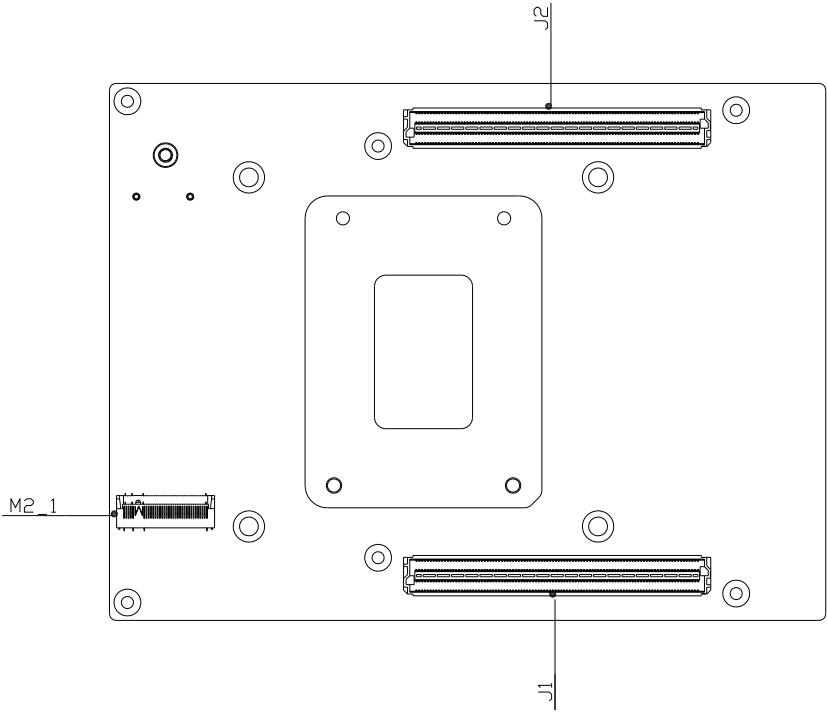

Bottom Side

2.3 List of Connectors

Please refer to the table below for all of the board's connectors that you can configure for your application

Label	Function
J1	Row A/B/C/D
J2	Row E/F/G/H
LPC1	LPC
JRTC1	Battery
M2	M.2 2280 M-Key
DIMM1	DDR5 SODIMM
DIMM2	DDR5 SODIMM

2.3.1 Row A/B/C/D Connector (J1)

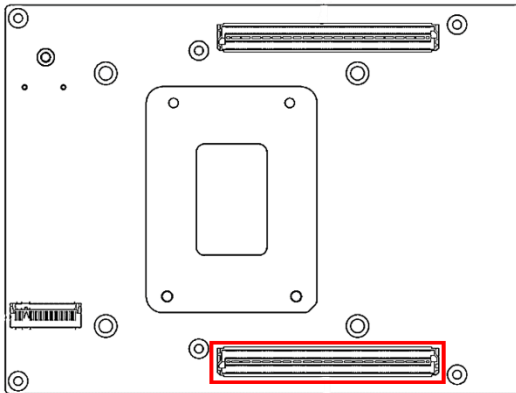

Client	Row A	Row B	Row C	Row D
01	VCC	VCC	VCC	VCC
02	VCC	PWRBTN#	RSTBTN#	VCC
03	VCC	VCC	VCC	VCC
04	VCC	THERMTRIP#	CARRIER_HOT#	VCC
05	VCC	VCC	VCC	VCC
06	VCC	TAMPER#	VIN_PWR_OK	VCC
07	VCC	VCC	VCC	VCC
08	VCC	SUS_S3#	SUS_S4_S5#	VCC
09	VCC	VCC	VCC	VCC
10	GND	WD_STROBE#	GND	WAKE0#

Client	Row A	Row B	Row C	Row D
11	BATLOW#	WD_OUT	FAN_PWMOUT	WAKE1#
12	PLTRST#	GND	FAN_TACHIN	GND
13	GND	USB5-	GND	USB1-
14	USB7-	USB5+	USB3-	USB1+
15	USB7+	GND	USB3+	GND
16	GND	USB4-	GND	USB0-
17	USB6-	USB4+	USB2-	USB0+
18	USB6+	GND	USB2+	GND
19	GND	I2S_LRCLK/SNDW_CLK3/HDA_SYNC	GND	DDI0_SDA_AUX-
20	DDI1_SDA_AUX-	I2S_DOUT/SNDW_DAT3/HDA_SDO	SNDW_DMIC_CLK1	DDI0_SCL_AUX+
21	DDI1_SCL_AUX+	I2S_MCLK/HDA_RST#	SNDW_DMIC_DAT1	GND
22	GND	I2S_DIN/SNDW_DAT2/HDA_SDI	GND	DDI0_PAIR0-
23	DDI1_PAIR0-	I2S_CLK/SNDW_CLK2/HDA_BCLK	SNDW_DMIC_CLK0	DDI0_PAIR0+
24	DDI1_PAIR0+	VCC_5V_SBY	SNDW_DMIC_DAT0	GND
25	GND	USB67_OC#	GND	DDI0_PAIR1-
26	DDI1_PAIR1-	USB45_OC#	DDI0_DDC_AUX_SEL	DDI0_PAIR1+
27	DDI1_PAIR1+	USB23_OC#	DDI1_DDC_AUX_SEL	GND
28	GND	USB01_OC#	DDI0_HPD	DDI0_PAIR2-
29	DDI1_PAIR2-	SML1_CLK	DDI1_HPD	DDI0_PAIR2+
30	DDI1_PAIR2+	SML1_DAT	eDP_HPD	GND
31	GND	PMCALERT#	eDP_VDD_EN	DDI0_PAIR3-
32	DDI1_PAIR3-	SML0_CLK	eDP_BKLT_EN	DDI0_PAIR3+
33	DDI1_PAIR3+	SML0_DAT	eDP_BKLTCTL	GND
34	GND	USB_PD_ALERT#	GND	AC_PRESENT
35	eDP_AUX-	USB_PD_I2C_CLK	USB1_AUX-	RSVD
36	eDP_AUX+	USB_PD_I2C_DAT	USB1_AUX+	GND
37	GND	USB_RT_ENA	GND	USB1_SSTX0-
38	eDP_TX0-	USB1_LSRX	USB1_SSRX0-	USB1_SSTX0+
39	eDP_TX0+	USB1_LSTX	USB1_SSRX0+	GND
40	GND	USB0_LSRX	GND	USB1_SSTX1-
41	eDP_TX1-	USB0_LSTX	USB1_SSRX1-	USB1_SSTX1+
42	eDP_TX1+	GND	USB1_SSRX1+	GND

Client	Row A	Row B	Row C	Row D
43	GND	USB0_AUX-	GND	USB0_SSTX0-
44	eDP_TX2-	USB0_AUX+	USB0_SSRX0-	USB0_SSTX0+
45	eDP_TX2+	LID#	USB0_SSRX0+	GND
46	GND	SLEEP#	GND	USB0_SSTX1-
47	eDP_TX3-	VCC_BOOT_SPI	USB0_SSRX1-	USB0_SSTX1+
48	eDP_TX3+	BOOT_SPI_CS#	USB0_SSRX1+	GND
49	GND	BSEL0	GND	SATA0_RX-
50	eSPI_IO0	BSEL1	BOOT_SPI_IO0	SATA0_RX+
51	eSPI_IO1	BSEL2	BOOT_SPI_IO1	GND
52	eSPI_IO2	eSPI_ALERT0#	BOOT_SPI_IO2	SATA0_TX-
53	eSPI_IO3	eSPI_ALERT1#	BOOT_SPI_IO3	SATA0_TX+
54	eSPI_CLK	eSPI_CS0#	BOOT_SPI_CLK	GND
55	GND	eSPI_CS1#	GND	SATA1_RX-
56	PCIe_CLKREQ0_LO#	eSPI_RST#	PCIe_REFCLK0_HI-	SATA1_RX+
57	PCIe_CLKREQ0_HI#	GND	PCIe_REFCLK0_HI+	GND
58	GND	PCIe_BMC_RX-	GND	SATA1_TX-
59	PCIe_BMC_TX-	PCIe_BMC_RX+	PCIe_REFCLK0_LO-	SATA1_TX+
60	PCIe_BMC_TX+	GND	PCIe_REFCLK0_LO+	GND
61	GND	PCIe08_RX-	GND	PCIe00_TX-
62	PCIe08_TX-	PCIe08_RX+	PCIe00_RX-	PCIe00_TX+
63	PCIe08_TX+	GND	PCIe00_RX+	GND
64	GND	PCIe09_RX-	GND	PCIe01_TX-
65	PCIe09_TX-	PCIe09_RX+	PCIe01_RX-	PCIe01_TX+
66	PCIe09_TX+	GND	PCIe01_RX+	GND
67	GND	PCIe10_RX-	GND	PCIe02_TX-
68	PCIe10_TX-	PCIe10_RX+	PCIe02_RX-	PCIe02_TX+
69	PCIe10_TX+	GND	PCIe02_RX+	GND
70	GND	PCIe11_RX-	GND	PCIe03_TX-
71	PCIe11_TX-	PCIe11_RX+	PCIe03_RX-	PCIe03_TX+
72	PCIe11_TX+	GND	PCIe03_RX+	GND
73	GND	PCIe12_RX-	GND	PCIe04_TX-
74	PCIe12_TX-	PCIe12_RX+	PCIe04_RX-	PCIe04_TX+
75	PCIe12_TX+	GND	PCIe04_RX+	GND
76	GND	PCIe13_RX-	GND	PCIe05_TX-
77	PCIe13_TX-	PCIe13_RX+	PCIe05_RX-	PCIe05_TX+
78	PCIe13_TX+	GND	PCIe05_RX+	GND

Client	Row A	Row B	Row C	Row D
79	GND	PCle14_RX-	GND	PCle06_TX-
80	PCle14_TX-	PCle14_RX+	PCle06_RX-	PCle06_TX+
81	PCle14_TX+	GND	PCle06_RX+	GND
82	GND	PCle15_RX-	GND	PCle07_TX-
83	PCle15_TX-	PCle15_RX+	PCle07_RX-	PCle07_TX+
84	PCle15_TX+	GND	PCle07_RX+	GND
85	GND	TEST#	GND	NBASET0_MDI0-
86	VCC_RTC	RSMRST_OUT#	SMB_CLK	NBASET0_MDI0+
87	SUS_CLK	UART1_TX	SMB_DAT	GND
88	GPIO_00	UART1_RX	SMB_ALERT#	NBASET0_MDI1-
89	GPIO_01	UART1_RTS#	UART0_TX	NBASET0_MDI1+
90	GPIO_02	UART1_CTS#	UART0_RX	GND
91	GPIO_03	IPMB_CLK	UART0_RTS#	NBASET0_MDI2-
92	GPIO_04	IPMB_DAT	UART0_CTS#	NBASET0_MDI2+
93	GPIO_05	GP_SPI_MOSI	I2C0_CLK	GND
94	GPIO_06	GP_SPI_MISO	I2C0_DAT	NBASET0_MDI3-
95	GPIO_07	GP_SPI_CS0#	I2C0_ALERT#	NBASET0_MDI3+
96	GPIO_08	GP_SPI_CS1#	I2C1_CLK	GND
97	GPIO_09	GP_SPI_CS2#	I2C1_DAT	NBASET0_LINKMA X
98	GPIO_10	GP_SPI_CS3#	NBASET0_SDP	BASET0_LINK_ID#
99	GPIO_11	GP_SPI_CLK	NBASET0_CTREF	NBASET0_LINK_AC T#
100	TYPE0	GP_SPI_ALERT#	TYPE1	TYPE2

2.3.2 Row E/F/G/H Connector (J2)

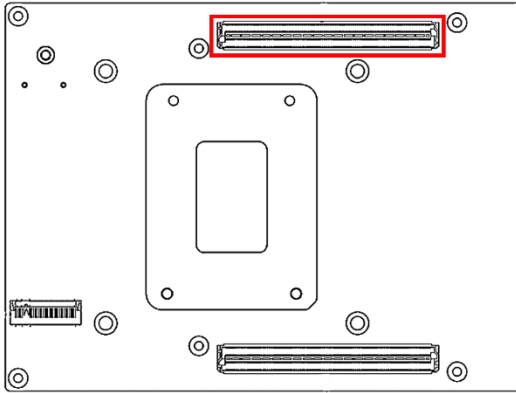

Client	Row E	Row F	Row G	Row H
01	RAPID_SHUTDOWN	FUSA_STATUS0	VCC_5V_SBY	GND
02	GND	FUSA_STATUS1	GND	USB2_SSTX0-
03	DDI2_SDA_AUX-	FUSA_ALERT#	USB2_SSRX0-	USB2_SSTX0+
04	DDI2_SCL_AUX+	FUSA_SPI_CS#	USB2_SSRX0+	GND
05	GND	FUSA_SPI_CLK	GND	USB2_SSTX1-
06	DDI2_PAIR0-	FUSA_SPI_MISO	USB2_SSRX1-	USB2_SSTX1+
07	DDI2_PAIR0+	FUSA_SPI_MOSI	USB2_SSRX1+	GND
08	GND	FUSA_SPI_ALERT	GND	USB3_SSTX0-
09	DDI2_PAIR1-	FUSA_VOLTAGE_ERR#	USB3_SSRX0-	USB3_SSTX0+
10	DDI2_PAIR1+	PROCHOT#	USB3_SSRX0+	GND
11	GND	CATERR#	GND	USB3_SSTX1-
12	DDI2_PAIR2-	RSVD	USB3_SSRX1-	USB3_SSTX1+
13	DDI2_PAIR2+	RSVD	USB3_SSRX1+	GND
14	GND	RSVD	GND	USB2_AUX-
15	DDI2_PAIR3-	RSVD	USB3_LSRX	USB2_AUX+
16	DDI2_PAIR3+	RSVD	USB3_LSTX	GND
17	GND	RSVD	USB2_LSRX	USB3_AUX-
18	DDI2_DDC_AUX_SEL	RSVD	USB2_LSTX	USB3_AUX+
19	DDI2_HPD	GND	PEG_LANE_REV#	GND
20	GND	PCIe32_RX-	GND	NC
21	PCIe32_TX-	PCIe32_RX+	NC	NC
22	PCIe32_TX+	GND	NC	NC

Client	Row E	Row F	Row G	Row H
23	GND	PCle33_RX-	NC	NC
24	PCle33_TX-	PCle33_RX+	NC	NC
25	PCle33_TX+	GND	NC	NC
26	GND	PCle34_RX-	NC	NC
27	PCle34_TX-	PCle34_RX+	NC	NC
28	PCle34_TX+	GND	NC	NC
29	GND	PCle35_RX-	NC	NC
30	PCle35_TX-	PCle35_RX+	NC	NC
31	PCle35_TX+	GND	NC	NC
32	NC	NC	NC	NC
33	NC	NC	NC	NC
34	NC	NC	NC	NC
35	NC	NC	NC	NC
36	NC	NC	NC	NC
37	NC	NC	NC	NC
38	NC	NC	NC	NC
39	NC	NC	NC	NC
40	NC	NC	NC	NC
41	NC	NC	NC	NC
42	NC	NC	NC	NC
43	NC	NC	NC	NC
44	GND	PCle16_RX-	GND	PCle24_TX-
45	PCle16_TX-	PCle16_RX+	PCle24_RX-	PCle24_TX+
46	PCle16_TX+	GND	PCle24_RX+	GND
47	GND	PCle17_RX-	GND	PCle25_TX-
48	PCle17_TX-	PCle17_RX+	PCle25_RX-	PCle25_TX+
49	PCle17_TX+	GND	PCle25_RX+	GND
50	GND	PCle18_RX-	GND	PCle26_TX-
51	PCle18_TX-	PCle18_RX+	PCle26_RX-	PCle26_TX+
52	PCle18_TX+	GND	PCle26_RX+	GND
53	GND	PCle19_RX-	GND	PCle27_TX-
54	PCle19_TX-	PCle19_RX+	PCle27_RX-	PCle27_TX+
55	PCle19_TX+	GND	PCle27_RX+	GND
56	GND	PCle20_RX-	GND	PCle28_TX-
57	PCle20_TX-	PCle20_RX+	PCle28_RX-	PCle28_TX+
58	PCle20_TX+	GND	PCle28_RX+	GND
59	GND	PCle21_RX-	GND	PCle29_TX-
60	PCle21_TX-	PCle21_RX+	PCle29_RX-	PCle29_TX+
61	PCle21_TX+	GND	PCle29_RX+	GND

Client	Row E	Row F	Row G	Row H
62	GND	PCle22_RX-	GND	PCle30_TX-
63	PCle22_TX-	PCle22_RX+	PCle30_RX-	PCle30_TX+
64	PCle22_TX+	GND	PCle30_RX+	GND
65	GND	PCle23_RX-	GND	PCle31_TX-
66	PCle23_TX-	PCle23_RX+	PCle31_RX-	PCle31_TX+
67	PCle23_TX+	GND	PCle31_RX+	GND
68	GND	RSVD	GND	RSVD
69	RSVD	RSVD	RSVD	RSVD
70	RSVD	GND	RSVD	GND
71	RSVD	NBASET1_MDI0-	GND	CSI1_RX0-
72	RSVD	NBASET1_MDI0+	CSI0_RX0-	CSI1_RX0+
73	RSVD	GND	CSI0_RX0+	GND
74	RSVD	NBASET1_MDI1-	GND	CSI1_RX1-
75	RSVD	NBASET1_MDI1+	CSI0_RX1-	CSI1_RX1+
76	RSVD	GND	CSI0_RX1+	GND
77	RSVD	NBASET1_MDI2-	GND	CSI1_RX2-
78	NBASET1_CTREF	NBASET1_MDI2+	CSI0_RX2-	CSI1_RX2+
79	NBASET1_SDP	GND	CSI0_RX2+	GND
80	NBASET1_LINK_MID#	NBASET1_MDI3-	GND	CSI1_RX3-
81	NBASET1_LINK_ACT#	NBASET1_MDI3+	CSI0_RX3-	CSI1_RX3+
82	NBASET1_LINK_MAX#	GND	CSI0_RX3+	GND
83	GND	RSVD	GND	CSI1_CLK-
84	RSVD	RSVD	CSI0_CLK-	CSI1_CLK+
85	RSVD	GND	CSI0_CLK+	GND
86	GND	ETH0_TX-	GND	CSI1_I2C_CLK
87	ETH0_RX-	ETH0_TX+	CSI0_I2C_CLK	CSI1_I2C_DAT
88	ETH0_RX+	GND	CSI0_I2C_DAT	CSI1_MCLK
89	GND	ETH1_TX-	CSI0_MCLK	CSI1_RST#
90	ETH1_RX-	ETH1_TX+	CSI0_RST#	CSI1_ENA
91	ETH1_RX+	GND	CSI0_ENA	GND
92	GND	PCle_REFCLK2-	GND	PCle_REFCLKIN0-
93	PCle_REFCLK1-	PCle_REFCLK2+	RSVD	PCle_REFCLKIN0+
94	PCle_REFCLK1+	GND	RSVD	GND
95	GND	RSVD	GND	PCle_REFCLKIN1-
96	PCle_CLKREQ1#	ETH0-1_PRSN#	ETH0-1_I2C_CLK	PCle_REFCLKIN1+
97	PCle_CLKREQ2#	ETH0-1_PHY_RST#	ETH0-1_I2C_DAT	GND

Client	Row E	Row F	Row G	Row H
98	PCIe_CLKREQ_OU T0#	ETH0_SDP	ETH0-1_PHY_INT#	ETH0-1_MDIO_CLK
99	PCIe_CLKREQ_OU T1#	ETH1_SDP	ETH0-1_INT#	ETH0-1_MDIO_DAT
100	PCIe_PERST_IN0#	PCIe_PERST_IN1#	PCIe_WAKE_OUT0 #	PCIe_WAKE_OUT1 #

2.3.3 LPC (LPC1)

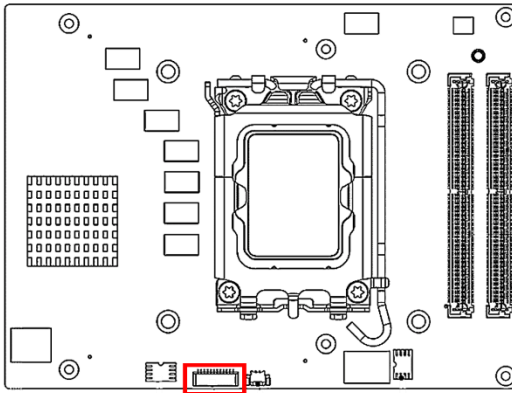

Pin	Pin Name	Signal Type
1	LPC_AD0	I/O
2	LPC_AD1	I/O
3	LPC_AD2	I/O
4	LPC_AD3	I/O
5	+V3P3S	PWR
6	LPC_FRAME#	I/O
7	BUF_PLT_RST#	I/O
8	GND	GND
9	CLK_PCI_COM	I/O
10	NC	-
11	NC	-
12	INT_SERIRQ	I/O

Note: Onboard LPC connector is for debug purposes only.

2.3.4 Battery (JRTC1)

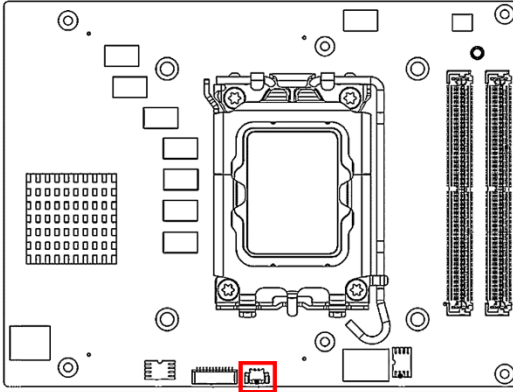

Pin	Pin Name	Signal Type
1	+VRTC_BATT	PWR
2	GND	GND

2.3.5 M.2 2280 M-Key (M2)

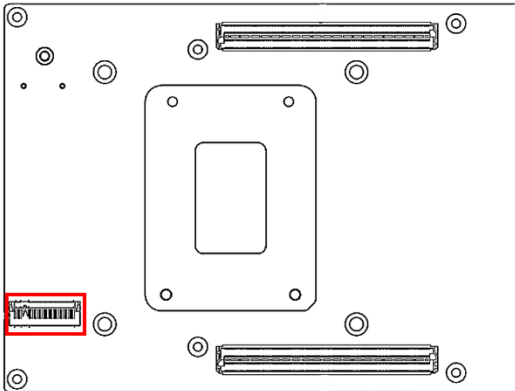

Pin	Pin Name	Signal Type
1	GND	GND
2	+V3P3S_NGFF	PWR
3	GND	GND
4	+V3P3S_NGFF	PWR
5	NC	-
6	CARD_PWR_OFF_N	I/O

Pin	Pin Name	Signal Type
7	NC	-
8	NC	-
9	GND	GND
10	M.2_LED#	I/O
11	NC	-
12	+V3P3S_NGFF	PWR
13	NC	-
14	+V3P3S_NGFF	PWR
15	GND	GND
16	+V3P3S_NGFF	PWR
17	NC	-
18	+V3P3S_NGFF	PWR
19	NC	-
20	NC	-
21	GND	GND
22	NC	-
23	NC	-
24	NC	-
25	NC	-
26	NC	-
27	GND	GND
28	NC	-
29	PCIE14_M.2_RXN	I/O
30	NC	-
31	PCIE14_M.2_RXP	I/O
32	NC	-
33	GND	GND
34	NC	-
35	PCIE14_M.2_TXN	I/O
36	NC	-
37	PCIE14_M.2_TXP	I/O
38	NC	-
39	GND	GND
40	SMB_CLK_2280	I/O
41	PCIE13_M.2_RXN	I/O
42	SMB_DATA_2280	I/O
43	PCIE13_M.2_RXP	I/O
44	NC	-
45	GND	GND

Pin	Pin Name	Signal Type
46	NC	-
47	PCIE13_M.2_TXN	I/O
48	NC	-
49	PCIE13_M.2_TXP	I/O
50	M.2_SSD_RST#	I/O
51	GND	GND
52	PCIE_M.2_CLKREQ#	I/O
53	PCIECLK_M.2_DN	I/O
54	PCIE_WAKE#	I/O
55	PCIECLK_M.2_DP	I/O
56	NC	-
57	GND	GND
58	NC	-
59	NC	-
60	-	-
61	-	-
62	-	-
63	-	-
64	-	-
65	-	-
66	-	-
67	NC	-
68	PCH_SUSCLK	I/O
69	GND	GND
70	+V3P3S_NGFF	PWR
71	GND	GND
72	+V3P3S_NGFF	PWR
73	GND	GND
74	+V3P3S_NGFF	PWR
75	GND	GND
76	GND	-
77	GND	-

Chapter 3

AMI BIOS Setup

3.1 System Test and Initialization

The board uses certain routines to test and initialize board hardware. If the routines encounter an error during the tests, you will either hear a few short beeps or see an error message on the screen. There are two kinds of errors: fatal and non-fatal. The system can usually continue the boot up sequence with non-fatal errors.

System configuration verification routines check the current system configuration stored in the CMOS memory and BIOS NVRAM. If a system configuration is not found or a system configuration data error is detected, the system will load the optimized default and re-boot with this default system configuration automatically.

There are four situations in which you will need to setup system configuration:

You are starting your system for the first time.

You have changed the hardware attached to your system.

The CMOS memory has lost power and the configuration information has been erased.

The HPC-RPSC CMOS memory uses a backup battery for data retention. The battery must be replaced if it runs out of power.

3.2 AMI BIOS Setup

The AMI BIOS ROM has a built-in Setup program that allows users to modify the basic system configuration. This information is stored in the battery-backed CMOS RAM and BIOS NVRAM so it retains the Setup information when the power is turned off.

To enter Setup, power on the computer and press immediately.

The function of each menu is as follows:

Main – Date and time can be set here. Use <Tab> to switch between date elements.

Advanced – Enable/disable boot option for legacy network devices.

System I/O – Enable/ Disable System input and output port.

Security – Password for setup administrator can be set here.

Boot – Enable/disable Quiet Boot option.

Save & Exit – Save changes and exit Setup.

3.3 Setup Submenu: Main

The screenshot displays the Aptio Setup - AMI Main menu. The menu is divided into two columns. The left column lists system information categories and their details, while the right column provides instructions and a legend for navigation keys.

Aptio Setup - AMI	
Main Advanced System I/O Security Boot Save & Exit	
== BIOS Information == HPC-RPSC R2.1 (HRPSAM21) (04/03/2024)	Set the Date. Use Tab to switch between Date elements. Default Ranges: Year: 1998-2199 Months: 1-12 Days: dependent on month
== EC Information == (HPC_E014) (12/22/2023)	
== CPU Information == 13th Gen Intel(R) Core(TM) i7-13700TE	++: Select Screen t1: Select Item Enter: Select +/-: Change Opt. F1: General Help F2: Previous Values F3: Optimized Defaults F4: Save & Exit ESC: Exit
== MEM Information == Total Memory 8192 MB Memory Frequency 4800 MHz	
== SATA Information == Serial ATA Port 0 Empty Serial ATA Port 1 Empty System Date [Thu 06/20/2024] System Time [17:30:15]	
Access Level Administrator	
Version 2.22.1293 Copyright (C) 2024 AMI	

3.4 Setup Submenu: Advanced

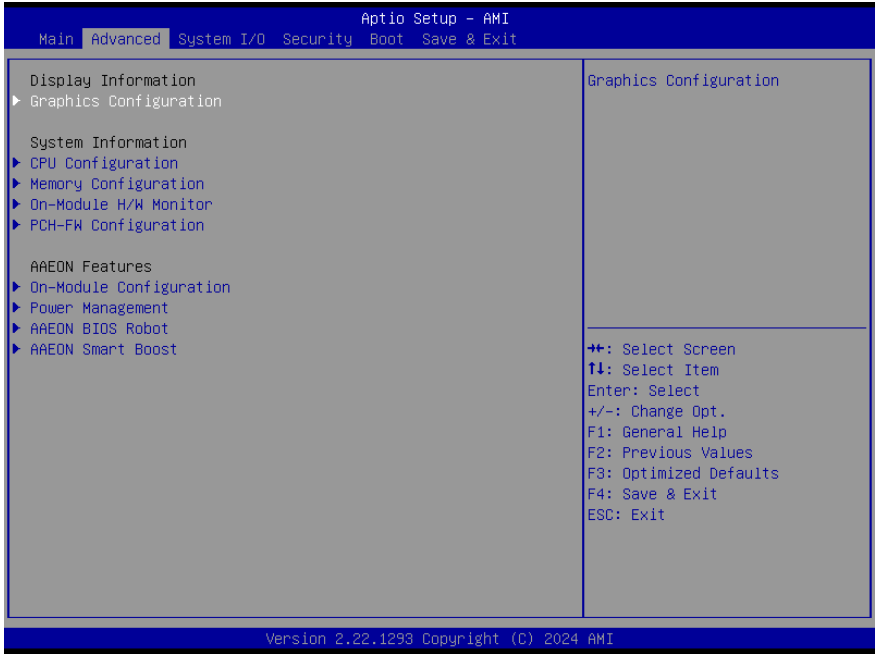

3.4.1 Graphics Configuration

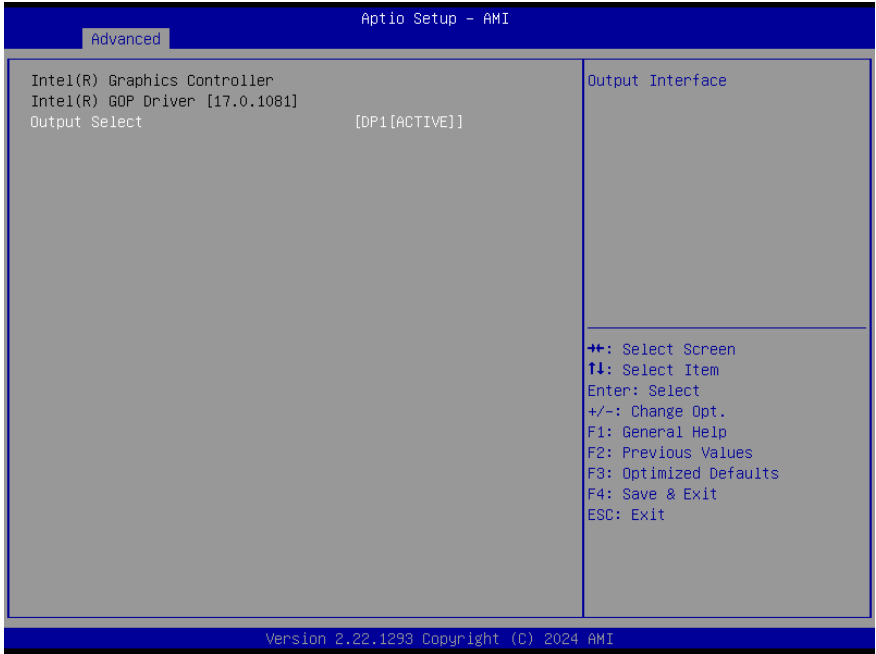

Options Summary		
Output Select	HDMI2[ACTIVE]	Optimal Default, Failsafe Default
Select HDMI2 for GOP Driver.		

3.4.2 CPU Configuration

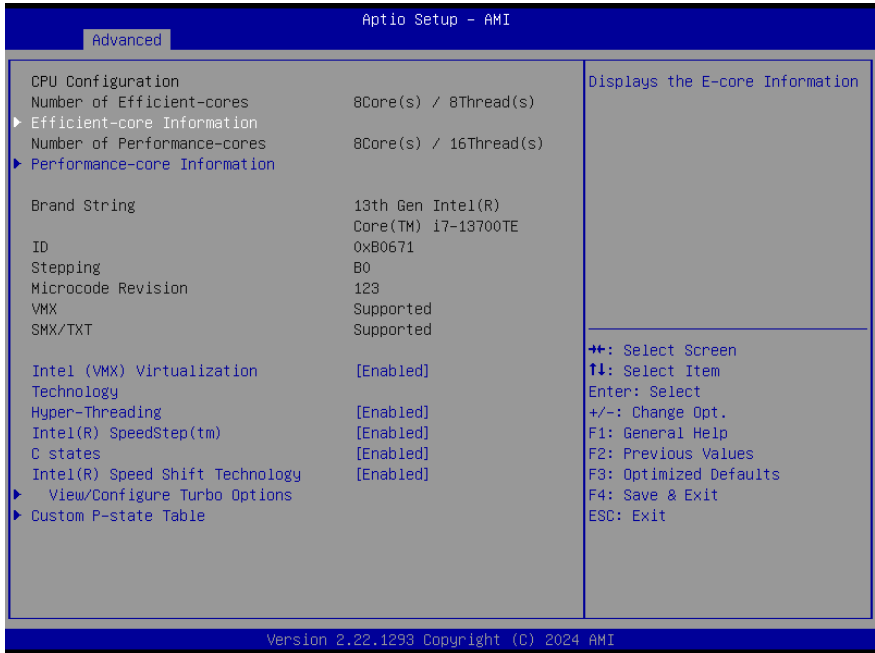

Options Summary		
Intel (VMX) Virtualization Technology	Disabled	
	Enabled	Optimal Default, Failsafe Default
When enabled, a VMM can utilize the additional hardware capabilities provided by Vanderpool Technology.		
Hyper-Threading	Disabled	
	Enabled	Optimal Default, Failsafe Default
Enable or Disable Hyper-Threading Technology.		
Intel(R) SpeedStep(tm)	Disabled	
	Enabled	Optimal Default, Failsafe Default
Allows more than two frequency ranges to be supported.		
C states	Disabled	
	Enabled	Optimal Default, Failsafe Default
Enable/Disable CPU Power Management. Allows CPU to go to C states when it's not 100% utilized		

Options Summary

Intel(R) Speed Shift Technology	Disabled	
	Enabled	Optimal Default, Failsafe Default
Enable/Disable Intel(R) Speed Shift Technology support. Enabling will expose the CPPC v2 interface to allow for hardware-controlled P-states.		

3.4.2.1 Efficient-Core Information

The screenshot shows the 'Advanced' menu of the Aptio Setup - AMI BIOS. The 'Efficient-core Information' section displays the following cache details:

L1 Data Cache	32 KB x 8
L1 Instruction Cache	64 KB x 8
L2 Cache	4096 KB x 2
L3 Cache	30 MB

Navigation instructions are listed on the right side of the screen:

- ++: Select Screen
- ↑↓: Select Item
- Enter: Select
- +/-: Change Opt.
- F1: General Help
- F2: Previous Values
- F3: Optimized Defaults
- F4: Save & Exit
- ESC: Exit

At the bottom of the screen, the text reads: Version 2.22.1293 Copyright (C) 2024 AMI

3.4.2.2 Performance-Core Information

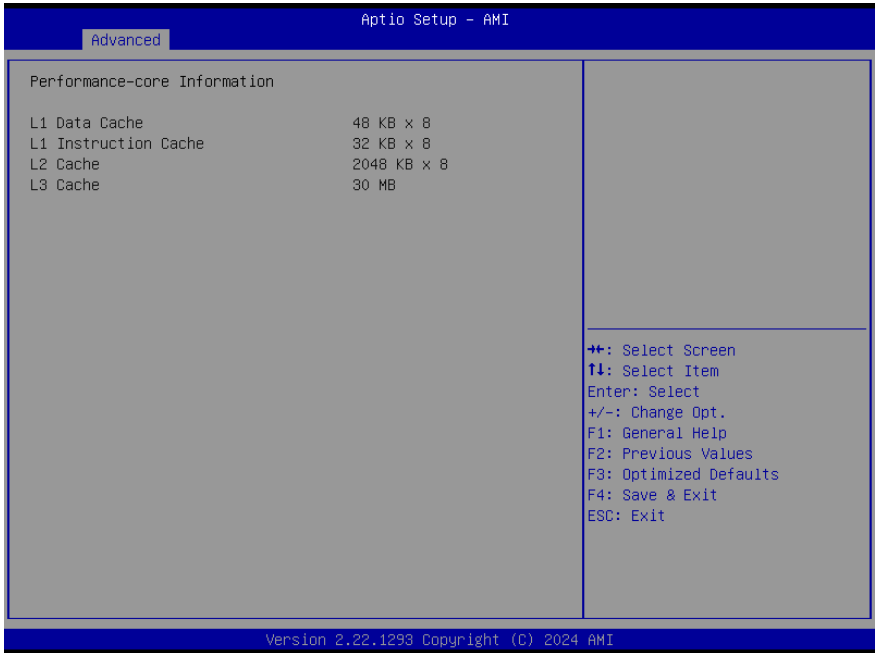

3.4.2.3 View/Configure Turbo Options

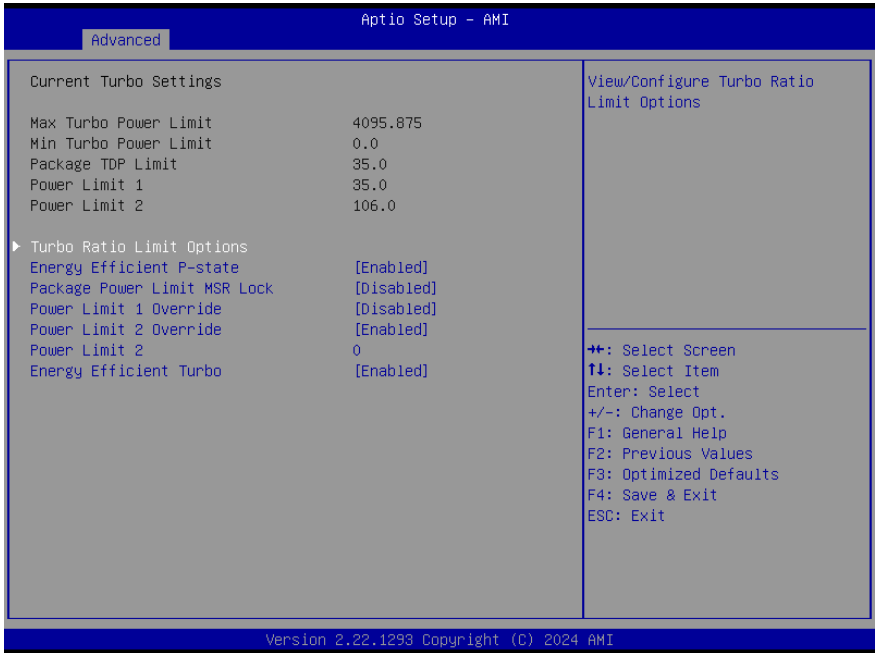

Options Summary		
Energy Efficient P-state	Disabled	
	Enabled	Optimal Default, Failsafe Default
Enable/Disable Energy Efficient P-state feature.		
Package Power Limit MSR Lock	Disabled	Optimal Default, Failsafe Default
	Enabled	
Enable/Disable locking of Package Power Limit settings.		
Power Limit 1 Override	Disabled	Optimal Default, Failsafe Default
	Enabled	
Enable/Disable Power Limit 1 override.		
Power Limit 2 Override	Disabled	
	Enabled	Optimal Default, Failsafe Default
Enable/Disable Power Limit 2 override.		
Power Limit 2	0	Optimal Default, Failsafe Default
Power Limit 2 value in Milli Watts.		

Options Summary		
Energy Efficient Turbo	Disabled	
	Enabled	Optimal Default, Failsafe Default
Enable/Disable Energy Efficient Turbo Feature.		

3.4.2.4 Custom P-state Table

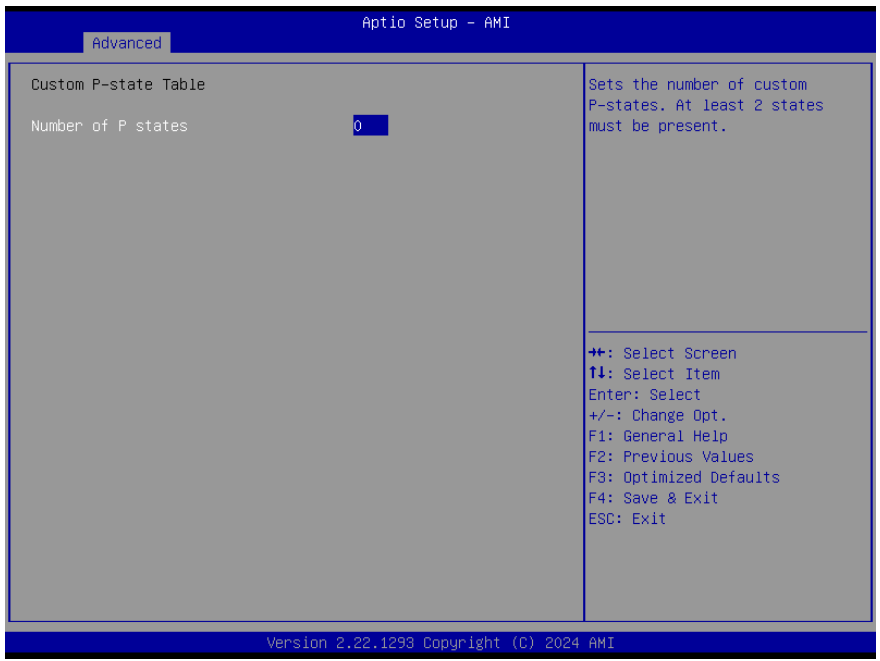

Options Summary		
Number of P states	0	Optimal Default, Failsafe Default
Sets the number of custom P-states.		

3.4.3 Memory Configuration

Aptio Setup - AMI

Advanced

Memory Configuration	
Memory RC Version	0.0.4.204
Total Memory	8192 MB
Memory Frequency	4800 MHz
tCL-tRCD-tRP-tRAS	40-39-39-77
MC 0 Ch 0 DIMM 0	Not Populated / Disabled
MC 1 Ch 0 DIMM 0	Populated & Enabled
Size	8192 MB (DDR5)
Number of Ranks	1
Manufacturer	Micron

++: Select Screen
↑↓: Select Item
Enter: Select
+/-: Change Opt.
F1: General Help
F2: Previous Values
F3: Optimized Defaults
F4: Save & Exit
ESC: Exit

Version 2.22.1293 Copyright (C) 2024 AMI

3.4.4 On-Module H/W Monitor

The screenshot displays the 'Advanced' menu of the Aptio Setup - AMI BIOS. The menu is divided into two columns. The left column lists various hardware monitoring parameters and their current values. The right column contains a legend for navigation keys. At the bottom of the screen, the version number and copyright information are displayed.

Aptio Setup - AMI	
Advanced	
CPU Temperature (PECI)	: +48 ℃
Thermal Sensor 1(T1)	: +33 ℃
Thermal Sensor 2(T2)	: +30 ℃
5VSB	: +5.149 V
+12V	: +12.072 V
VMEM	: +1.107 V
Smart Fan Configuration	
FAN 1	: 3564 RPM
FAN 1	[Auto - Slope Linear]
PWM signal	[Non-inverting]
Thermal Monitoring	[CPU Temperature (PECI)]
Start-Up temperature	10
Shut-Off temperature	0
START PWM	30
Slope (PWM)	[1 (PWM)]

Legend:

- ↔: Select Screen
- ↑↓: Select Item
- Enter: Select
- +/-: Change Opt.
- F1: General Help
- F2: Previous Values
- F3: Optimized Defaults
- F4: Save & Exit
- ESC: Exit

Version 2.22.1293 Copyright (C) 2024 AMI

3.4.4.1 Smart Fan Mode Configuration

FAN 1: Full Mode

The screenshot shows the BIOS 'Advanced' menu with the following settings:

- CPU Temperature (PECI) : +47 °C
- Thermal Sensor 1(T1) : +33 °C
- Thermal Sensor 2(T2) : +30 °C
- 5VSB : +5.149 V
- +12V : +12.053 V
- VMEM : +1.107 V
- Smart Fan Configuration :
 - FAN 1 : 3422 RPM
 - FAN 1 : [Full Mode]

Navigation keys listed at the bottom right:

- +/: Select Screen
- ↑↓: Select Item
- Enter: Select
- +/-: Change Opt.
- F1: General Help
- F2: Previous Values
- F3: Optimized Defaults
- F4: Save & Exit
- ESC: Exit

Version 2.22.1293 Copyright (C) 2024 AMI

Options Summary		
FAN 1	Full Mode	Optimal Default, Failsafe Default
	Manual Mode by PWM	
	Auto -Slope Linear	
Smart Fan Mode Select.		
PWM signal	Non-inverting	Optimal Default, Failsafe Default
	Inverting	
Select output PWM of inverting or non-inverting signal.		

FAN 1: Manual Mode by PWM

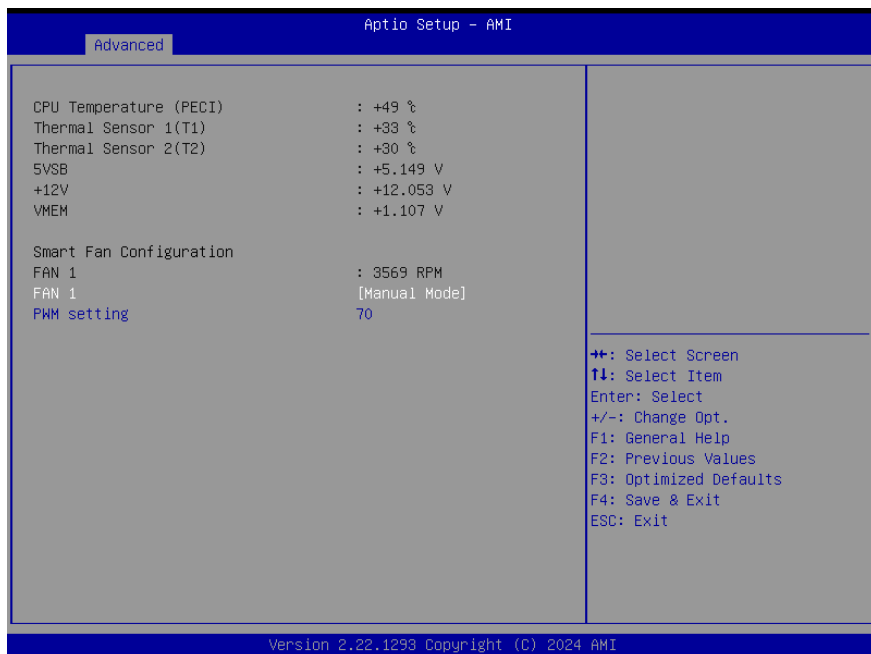

Options Summary		
FAN 1	Full Mode	
	Manual Mode	Optimal Default, Failsafe Default
	Auto -Slope Linear	
Set Fan at fixed Duty-Cycle Min=0 Max=100 Please input Dec number:		
Manual Setting	70	Optimal Default, Failsafe Default
Set Fan at fixed Duty-Cycle Min=0 Max=100 Please input Dec number:		

FAN 1: Auto Mode by PWM

Aptio Setup - AMI

Advanced

CPU Temperature (PECI)	: +31 ℃	
Thermal Sensor 1(T1)	: +28 ℃	
Thermal Sensor 2(T2)	: +26 ℃	
5VSB	: +5.144 V	
+12V	: +12.128 V	
VMEM	: +1.104 V	
Smart Fan Configuration		
FAN 1	: 2139 RPM	
FAN 1	[Auto - Slope Linear]	
PWM signal	[Non-inverting]	
Thermal Monitoring	[CPU Temperature (PECI)]	
Start-Up temperature	10	
Shut-Off temperature	0	
START PWM	30	
Slope (PWM)	[1 (PWM)]	
		++: Select Screen ↓↑: Select Item Enter: Select +/-: Change Opt. F1: General Help F2: Previous Values F3: Optimized Defaults F4: Save & Exit ESC: Exit

Version 2.22.1287 Copyright (C) 2023 AMI

Options Summary		
FAN 1	Full Mode	
	Manual Mode	
	Auto -Slope Linear	Optimal Default, Failsafe Default
Smart Fan Mode Select.		
PWM signal	Non-inverting	Optimal Default, Failsafe Default
	Inverting	
Select output PWM of inverting or non-inverting signal.		
Thermal Monitoring	CPU Temperature (PECI)	Optimal Default, Failsafe Default
	Thermal Source 1(T1)	
	Thermal Source 2(T2)	
Select thermal monitoring source.		
Start-Up temperature	10	Optimal Default, Failsafe Default
Start-Up temperature		
Start-Off temperature	0	Optimal Default, Failsafe Default
Start-Off temperature		
Start PWM	30	Optimal Default, Failsafe Default

Options Summary

Start PWM.

Slope (PWM)	0 (PWM)	
	1 (PWM)	Optimal Default, Failsafe Default
	2 (PWM)	
	4 (PWM)	
	8 (PWM)	
	16 (PWM)	
	32(PWM)	
	64(PWM)	

Slope (PWM)

3.4.5 PCH-FW Configuration

Aptio Setup - AMI

Advanced

ME Firmware Version	16.1.30.2330	Configure Management Engine Technology Parameters
▶ Firmware Update Configuration		
		++: Select Screen ↑↓: Select Item Enter: Select +/-: Change Opt. F1: General Help F2: Previous Values F3: Optimized Defaults F4: Save & Exit ESC: Exit

Version 2.22.1293 Copyright (C) 2024 AMI

3.4.5.1 Firmware Update Configuration

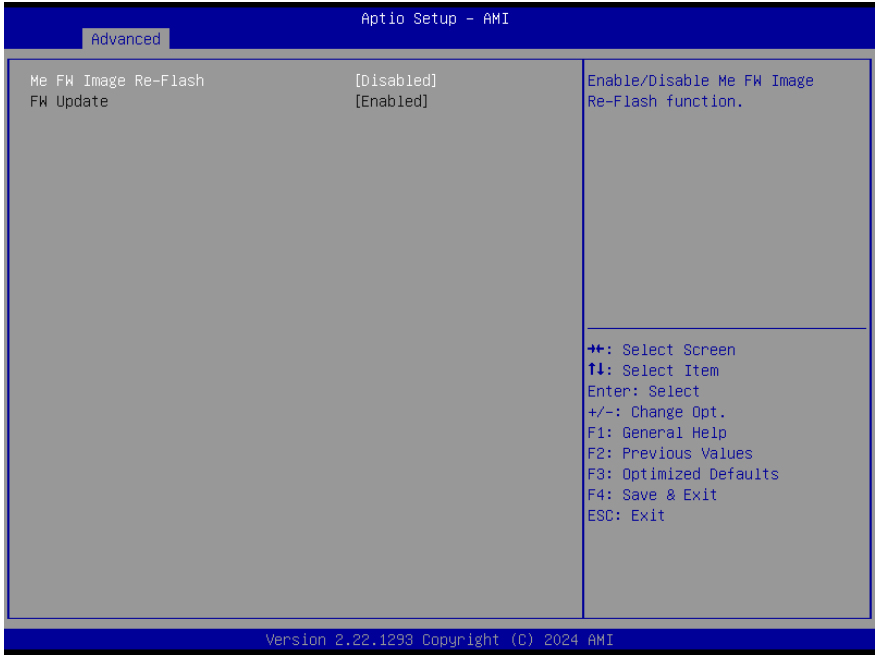

Options Summary		
Me FW Image Re-Flash	Disabled	Optimal Default, Failsafe Default
	Enabled	
Enable/ Disable Me FW Image Re-Flash Function.		

3.4.6 On-Module Configuration



Options Summary		
Battery Management	Disabled	Optimal Default, Failsafe Default
	One Battery	
Enable to support battery in ACPI OS by I2C_CK, I2C_DAT (B33, B34)		

3.4.7 Power Management

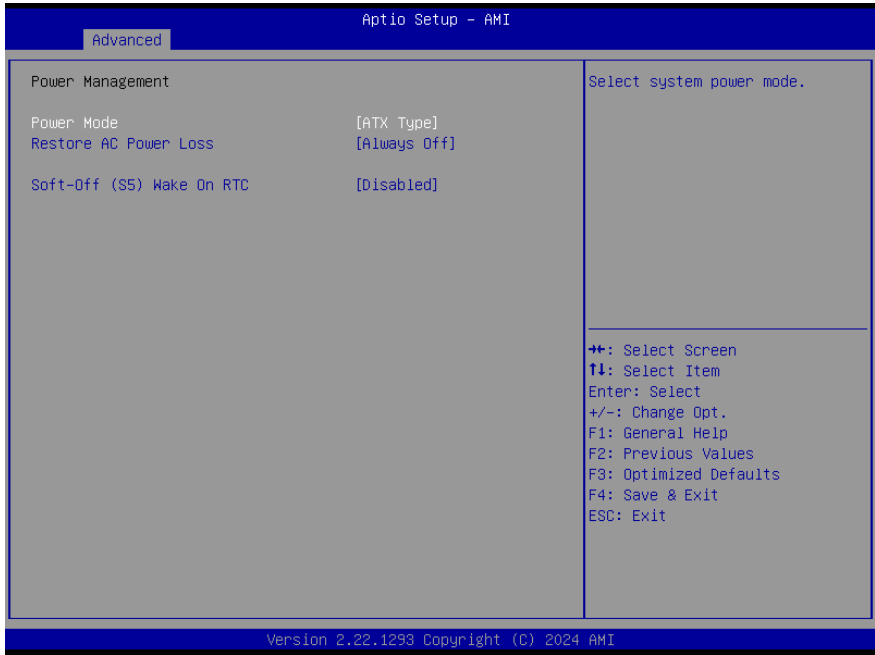

Options Summary		
Power Mode	ATX Type	Optimal Default, Failsafe Default
	AT Type	
Select system power mode.		
Restore AC Power Loss	Last State	
	Always On	
	Always Off	Optimal Default, Failsafe Default
SIO Restore AC Power Loss: To decide the behavior after system power cut then resupply. Note: The CMOS battery must be present.		
Soft-Off (S5) Wake On RTC	Disabled	Optimal Default, Failsafe Default
	Fixed Time	
	Dynamic Time	
	Bypass	
Fixed Time: System will wake on the hr::mn::sec Specified.		
Dynamic Time: System will wake on the current time + Increase minute(s)		
Bypass: BIOS will not control RTC wake function during system shutdown.		

3.4.8 AAEON BIOS Robot



Options Summary		
Sends watch dog before BIOS POST	Disabled	Optimal Default, Failsafe Default
	Enabled	
Enabled - Robot set Watch Dog Timer (WDT) right after power on, before BIOS start POST process. And then Robot will clear WDT on completion of POST. WDT will reset system automatically if it is not cleared before its timer counts down to zero.		
Sends watch dog before booting OS	Disabled	Optimal Default, Failsafe Default
	Enabled	
Enabled - Robot set Watch Dog Timer (WDT) after POST completion before BIOS transfer control to OS. Warning: Before enabling this function, a program in OS must be in responsible for clearing WDT. Also, this function should be disabled if OS is going to update itself.		
Delayed POST (PEI phase)	Disabled	Optimal Default, Failsafe Default
	Enabled	
Enabled - Robot holds BIOS from starting POST, right after power on. This allows BIOS POST to start with stable power or start after system is physically warmed-up.		

Options Summary

Note: Robot does this before 'Send watch dog'.

Delayed POST (DXE phase)	Disabled	Optimal Default, Failsafe Default
	Enabled	

Enabled - Robot holds BIOS before POST completion. This allows BIOS POST to start with stable power or start after system is physically warmed-up.

Note: Robot does this after 'Send watch dog before BIOS POST'.

Reset system once	Disabled	Optimal Default, Failsafe Default
	Enabled	

Enabled - Robot resets system for one time on each boot. This will send a soft or hand reset to onboard devices, thus puts devices to more stable state.

3.4.9 AAEON Smart Boost

AAEON Smart Boost: Smart Boost

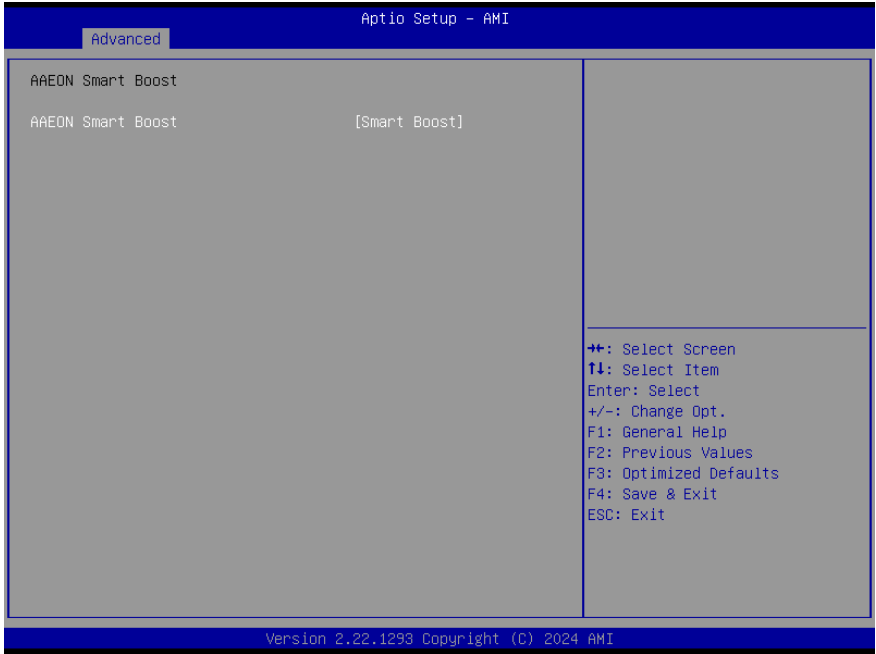

Options Summary		
AAEON Smart Boost	Smart Boost	Optimal Default, Failsafe Default
	Maximum Performance	
	Good Stability	
	Disable	
AAEON Smart Boost Mode Select.		

AAEON Smart Boost: Maximum Performance

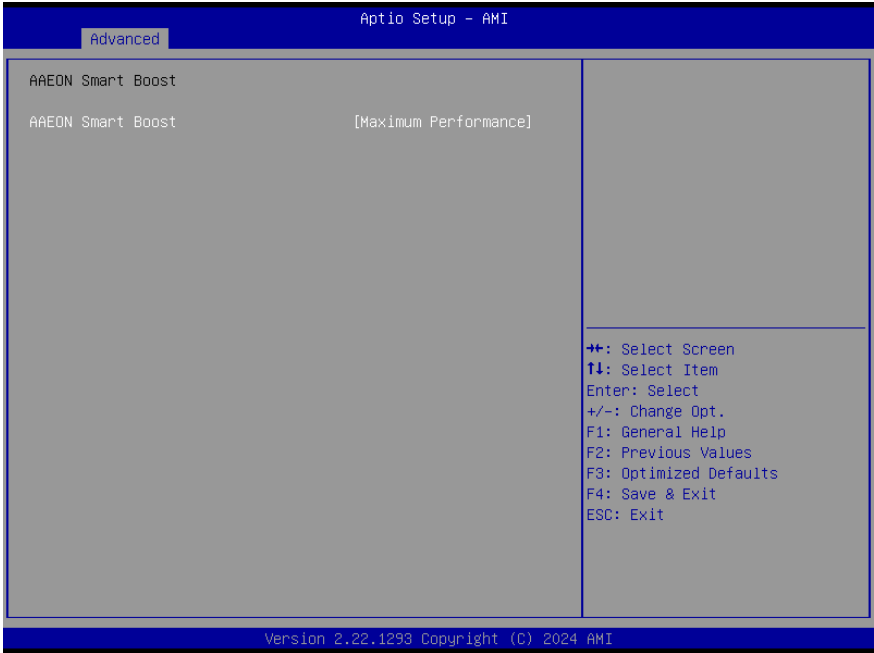

Options Summary		
AAEON Smart Boost	Smart Boost	
	Maximum Performance	Optimal Default, Failsafe Default
	Good Stability	
	Disable	
AAEON Smart Boost Mode Select.		

AAEON Smart Boost: Good Stability



Options Summary		
AAEON Smart Boost	Smart Boost	
	Maximum Performance	
	Good Stability	Optimal Default, Failsafe Default
	Disable	
AAEON Smart Boost Mode Select.		
CPU Performance	50%	
	60%	
	70%	
	80%	
	90%	
	100%	Optimal Default, Failsafe Default
CPU Performance.		

AAEON Smart Boost: Disable

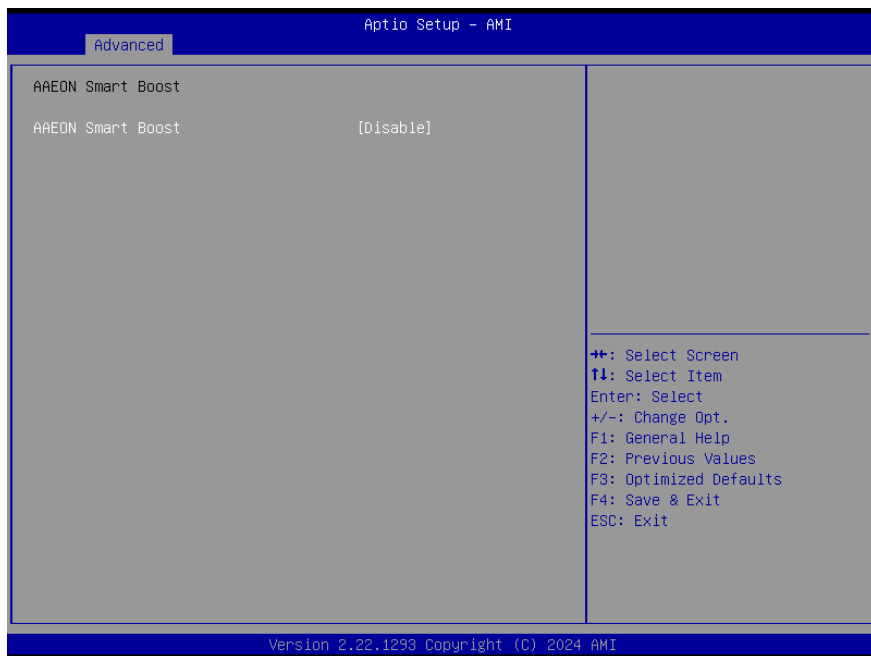

Options Summary		
AAEON Smart Boost	Smart Boost	
	Maximum Performance	
	Good Stability	
	Disable	Optimal Default, Failsafe Default
AAEON Smart Boost Mode Select.		

3.5 Setup Submenu: System I/O

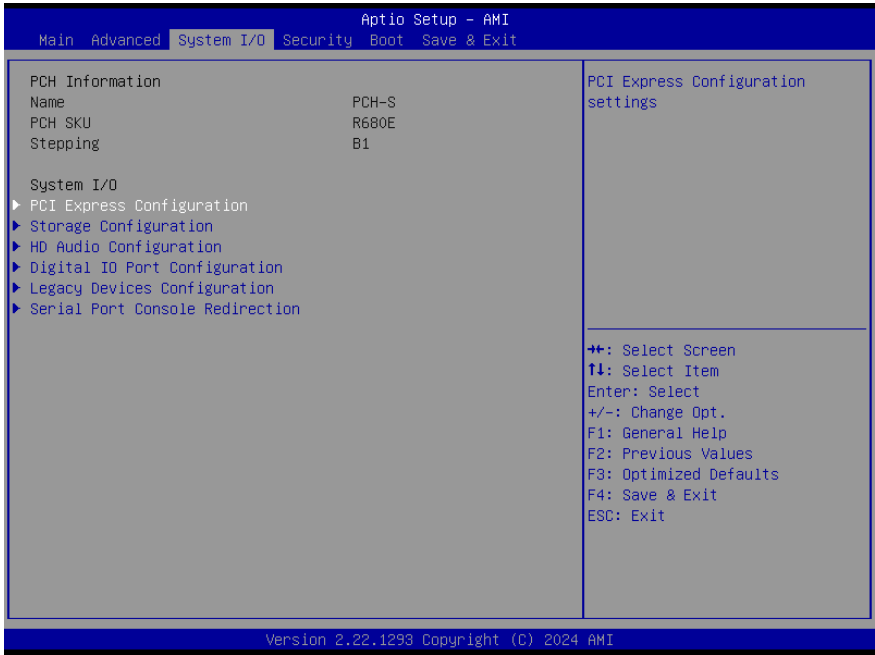

3.5.1 PCI Express Configuration

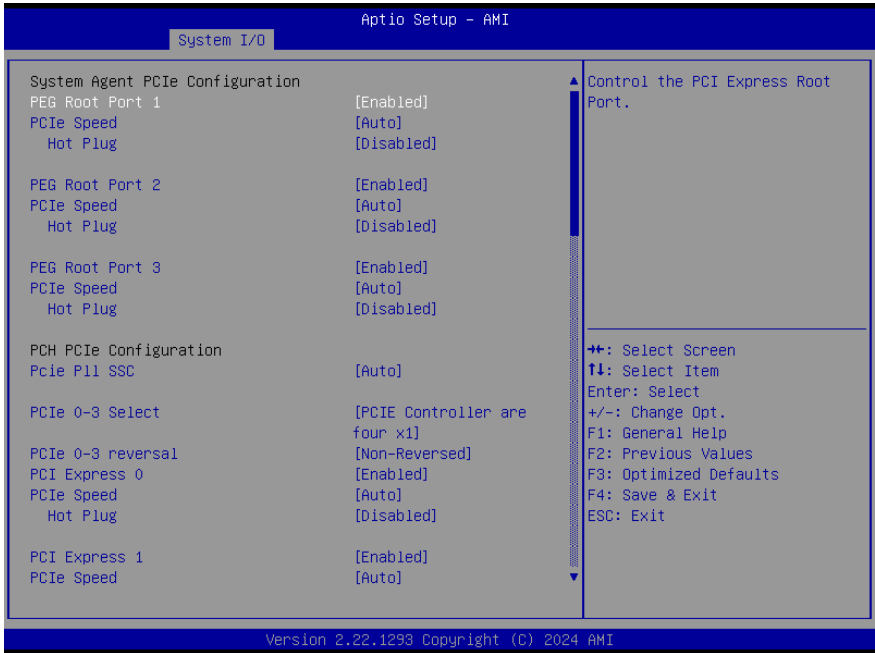

Options Summary		
PEG Root Port 1	Disabled	
	Enabled	Optimal Default, Failsafe Default
Control the PCI Express Root Port.		
PCIe Speed	Auto	Optimal Default, Failsafe Default
	Gen1	
	Gen2	
	Gen3	
	Gen4	
Configure PCIe Speed.		
Hot Plug	Disabled	Optimal Default, Failsafe Default
	Enabled	
PCI Express Hot Plug Enable/Disable.		
PEG Root Port 2	Disabled	
	Enabled	Optimal Default, Failsafe Default
Control the PCI Express Root Port.		

Options Summary		
PCIe Speed	Auto	Optimal Default, Failsafe Default
	Gen1	
	Gen2	
	Gen3	
	Gen4	
Configure PCIe Speed.		
Hot Plug	Disabled	Optimal Default, Failsafe Default
	Enabled	
PCI Express Hot Plug Enable/Disable.		
PEG Root Port 3	Disabled	
	Enabled	Optimal Default, Failsafe Default
Control the PCI Express Root Port.		
PCIe Speed	Auto	Optimal Default, Failsafe Default
	Gen1	
	Gen2	
	Gen3	
	Gen4	
Configure PCIe Speed.		
Hot Plug	Disabled	Optimal Default, Failsafe Default
	Enabled	
PCI Express Hot Plug Enable/Disable.		
Pcie Pll SSC	Auto	Optimal Default, Failsafe Default
	0.0%	
	0.1%	
	0.2%	
	0.3%	
	0.4%	
	0.5%	
	0.6%	
	0.7%	
	0.8%	
	0.9%	
	1.0%	
	1.1%	
	1.2%	
	1.3%	
	1.4%	
	1.5%	
1.6%		

Options Summary		
Pcie Pll SSC	1.7%	
	1.8%	
	1.9%	
	2.0%	
	Disable	
Pcie Pll SSC.		
PCIe 0-3 Select	PCIe Controller are four ×1	Optimal Default, Failsafe Default
	PCIe Controller are one ×2 and two ×1	
	PCIe Controller are two ×2	
	PCIe Controller are one ×4	
PCIe Controller Setting.		
PCIe 0-3 reversal	Non-Reversed	Optimal Default, Failsafe Default
	Reversed	
PCIe Lane reversal		
PCI Express 0	Disabled	
	Enabled	Optimal Default, Failsafe Default
Control the PCI Express Root Port.		
PCIe Speed	Auto	Optimal Default, Failsafe Default
	Gen1	
	Gen2	
	Gen3	
Configure PCIe Speed.		
Hot Plug	Disabled	Optimal Default, Failsafe Default
	Enabled	
PCI Express Hot Plug Enable/Disable.		
PCI Express 1	Disabled	
	Enabled	Optimal Default, Failsafe Default
Control the PCI Express Root Port.		
PCIe Speed	Auto	Optimal Default, Failsafe Default
	Gen1	
	Gen2	
	Gen3	
Configure PCIe Speed.		

Options Summary

Hot Plug	Disabled	Optimal Default, Failsafe Default
	Enabled	
PCI Express Hot Plug Enable/Disable.		

System I/O

Aptio Setup - AMI

PCI Express 2	[Enabled]	Control the PCI Express Root Port.
PCIe Speed	[Auto]	
Hot Plug	[Disabled]	
PCI Express 3	[Enabled]	
PCIe Speed	[Auto]	
Hot Plug	[Disabled]	
PCIe 4-7 Select	[PCIe Controller are four x1]	
PCIe 4-7 reversal	[Non-Reversed]	
PCI Express 4	[Enabled]	
PCIe Speed	[Auto]	
Hot Plug	[Disabled]	++: Select Screen ↑↓: Select Item Enter: Select +/-: Change Opt. F1: General Help F2: Previous Values F3: Optimized Defaults F4: Save & Exit ESC: Exit
PCI Express 5	[Enabled]	
PCIe Speed	[Auto]	
Hot Plug	[Disabled]	
PCI Express 6	[Enabled]	
PCIe Speed	[Auto]	
Hot Plug	[Disabled]	
PCI Express 7	[Enabled]	

Version 2.22.1293 Copyright (C) 2024 AMI

Options Summary

PCI Express 2	Disabled	
	Enabled	Optimal Default, Failsafe Default
Control the PCI Express Root Port.		
PCIe Speed	Auto	Optimal Default, Failsafe Default
	Gen1	
	Gen2	
	Gen3	
Configure PCIe Speed.		
Hot Plug	Disabled	Optimal Default, Failsafe Default
	Enabled	
PCI Express Hot Plug Enable/Disable.		

Options Summary		
PCI Express 3	Disabled	
	Enabled	Optimal Default, Failsafe Default
Control the PCI Express Root Port.		
PCIe Speed	Auto	Optimal Default, Failsafe Default
	Gen1	
	Gen2	
	Gen3	
Configure PCIe Speed.		
Hot Plug	Disabled	Optimal Default, Failsafe Default
	Enabled	
PCI Express Hot Plug Enable/Disable.		
PCIe 4-7 Select	PCIe Controller are four ×1	Optimal Default, Failsafe Default
	PCIe Controller are one ×2 and two ×1	
	PCIe Controller are two ×2	
	PCIe Controller is one ×4	
PCIe Controller Setting.		
PCIe 4-7 reversal	Non-Reversed	Optimal Default, Failsafe Default
	Reversed	
PCIe Lane reversal		
PCI Express 4	Disabled	
	Enabled	Optimal Default, Failsafe Default
Control the PCI Express Root Port.		
PCIe Speed	Auto	Optimal Default, Failsafe Default
	Gen1	
	Gen2	
	Gen3	
Configure PCIe Speed.		
Hot Plug	Disabled	Optimal Default, Failsafe Default
	Enabled	
PCI Express Hot Plug Enable/Disable.		
PCI Express 5	Disabled	
	Enabled	Optimal Default, Failsafe Default
Control the PCI Express Root Port.		

Options Summary		
PCIe Speed	Auto	Optimal Default, Failsafe Default
	Gen1	
	Gen2	
	Gen3	
Configure PCIe Speed.		
Hot Plug	Disabled	Optimal Default, Failsafe Default
	Enabled	
PCI Express Hot Plug Enable/Disable.		
PCI Express 6	Disabled	
	Enabled	Optimal Default, Failsafe Default
Control the PCI Express Root Port.		
PCIe Speed	Auto	Optimal Default, Failsafe Default
	Gen1	
	Gen2	
	Gen3	
Configure PCIe Speed.		
Hot Plug	Disabled	Optimal Default, Failsafe Default
	Enabled	
PCI Express Hot Plug Enable/Disable.		

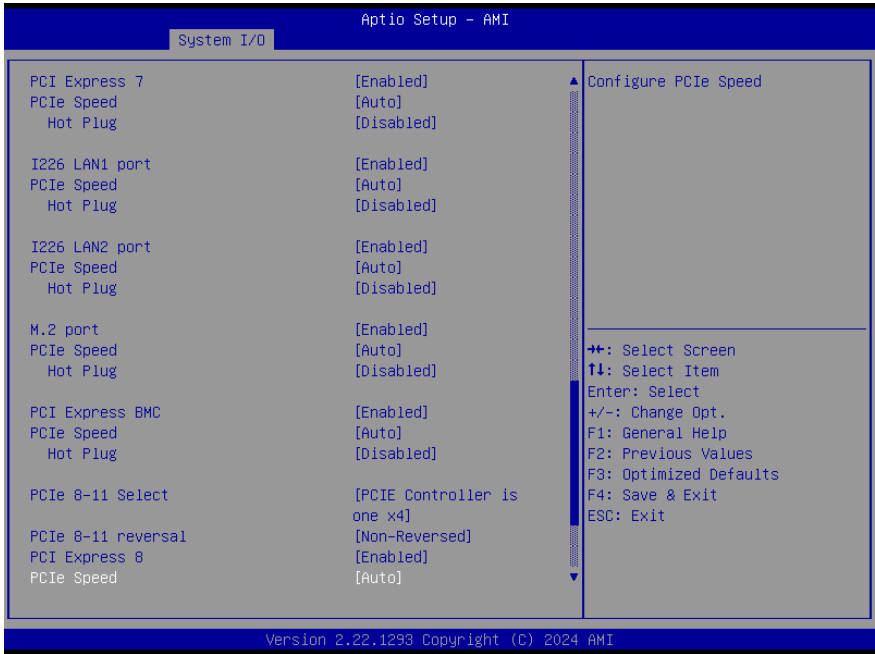

Options Summary

PCI Express 7	Disabled	
	Enabled	Optimal Default, Failsafe Default
Control the PCI Express Root Port.		
PCIe Speed	Auto	Optimal Default, Failsafe Default
	Gen1	
	Gen2	
	Gen3	
Configure PCIe Speed.		
Hot Plug	Disabled	Optimal Default, Failsafe Default
	Enabled	
PCI Express Hot Plug Enable/Disable.		
I226 LAN1 port	Disabled	
	Enabled	Optimal Default, Failsafe Default
Control the PCI Express Root Port.		
PCIe Speed	Auto	Optimal Default, Failsafe Default
	Gen1	
	Gen2	
	Gen3	

Options Summary		
Configure PCIe Speed.		
Hot Plug	Disabled	Optimal Default, Failsafe Default
	Enabled	
PCI Express Hot Plug Enable/Disable.		
I226 LAN2 port	Disabled	
	Enabled	Optimal Default, Failsafe Default
Control the PCI Express Root Port.		
PCIe Speed	Auto	Optimal Default, Failsafe Default
	Gen1	
	Gen2	
	Gen3	
Configure PCIe Speed.		
Hot Plug	Disabled	Optimal Default, Failsafe Default
	Enabled	
PCI Express Hot Plug Enable/Disable.		
M.2 port	Disabled	
	Enabled	Optimal Default, Failsafe Default
Control the PCI Express Root Port.		
PCIe Speed	Auto	Optimal Default, Failsafe Default
	Gen1	
	Gen2	
	Gen3	
Configure PCIe Speed.		
Hot Plug	Disabled	Optimal Default, Failsafe Default
	Enabled	
PCI Express Hot Plug Enable/Disable.		
PCI Express BMC	Disabled	
	Enabled	Optimal Default, Failsafe Default
Control the PCI Express Root Port.		
PCIe Speed	Auto	Optimal Default, Failsafe Default
	Gen1	
	Gen2	
	Gen3	
Configure PCIe Speed.		
Hot Plug	Disabled	Optimal Default, Failsafe Default
	Enabled	
Configure PCIe Speed.		
PCIe 8-11 Select	PCIe Controller are four ×1	

Options Summary		
PCIe 8-11 Select	PCIe Controller are one x2 and two x1	
	PCIe Controller are two x2	
	PCIe Controller is one x4	Optimal Default, Failsafe Default
PCIe Controller Setting.		
PCIe 8-11 reversal	Non-Reversed	Optimal Default, Failsafe Default
	Reversed	
PCIe Lane reversal		
PCI Express 8	Disabled	
	Enabled	Optimal Default, Failsafe Default
Control the PCI Express Root Port.		
PCIe Speed	Auto	Optimal Default, Failsafe Default
	Gen1	
	Gen2	
	Gen3	
Configure PCIe Speed.		
Hot Plug	Disabled	Optimal Default, Failsafe Default
	Enabled	
PCI Express Hot Plug Enable/Disable.		

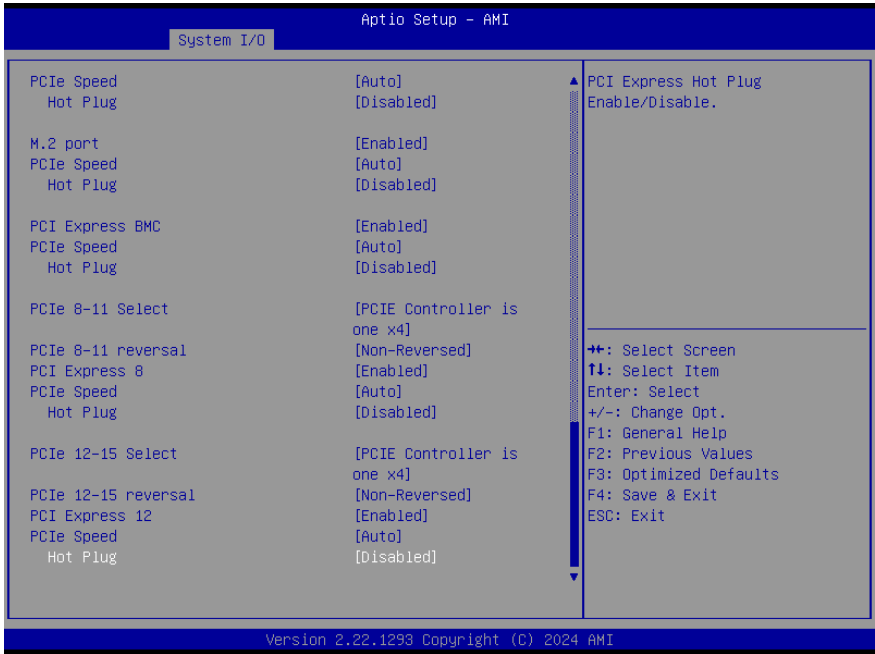

Options Summary

PCIe 12-15 Select	PCIe Controller are four x1	
	PCIe Controller are one x2 and two x1	
	PCIe Controller are two x2	
	PCIe Controller is one x4	Optimal Default, Failsafe Default
PCIe Controller Setting.		
PCIe 12-15 reversal	Non-Reversed	Optimal Default, Failsafe Default
	Reversed	
PCIe Lane reversal		
PCI Express 12	Disabled	
	Enabled	Optimal Default, Failsafe Default
Control the PCI Express Root Port.		
PCIe Speed	Auto	Optimal Default, Failsafe Default
	Gen1	
	Gen2	

Options Summary

PCIe Speed	Gen3	
Configure PCIe Speed.		
Hot Plug	Disabled	Optimal Default, Failsafe Default
	Enabled	
PCI Express Hot Plug Enable/Disable.		

3.5.2 Storage Configuration

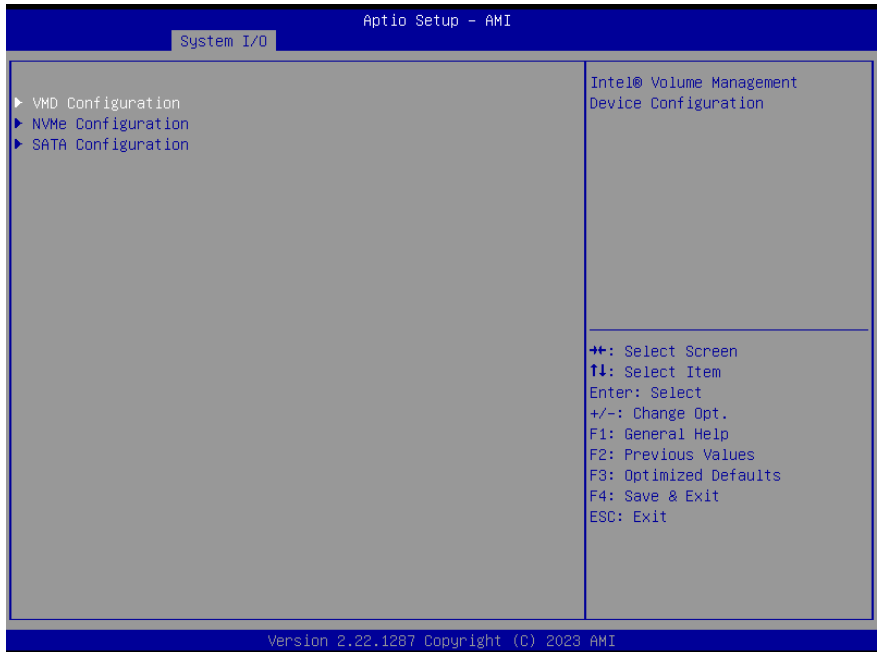

3.5.3 VMD Setup Menu

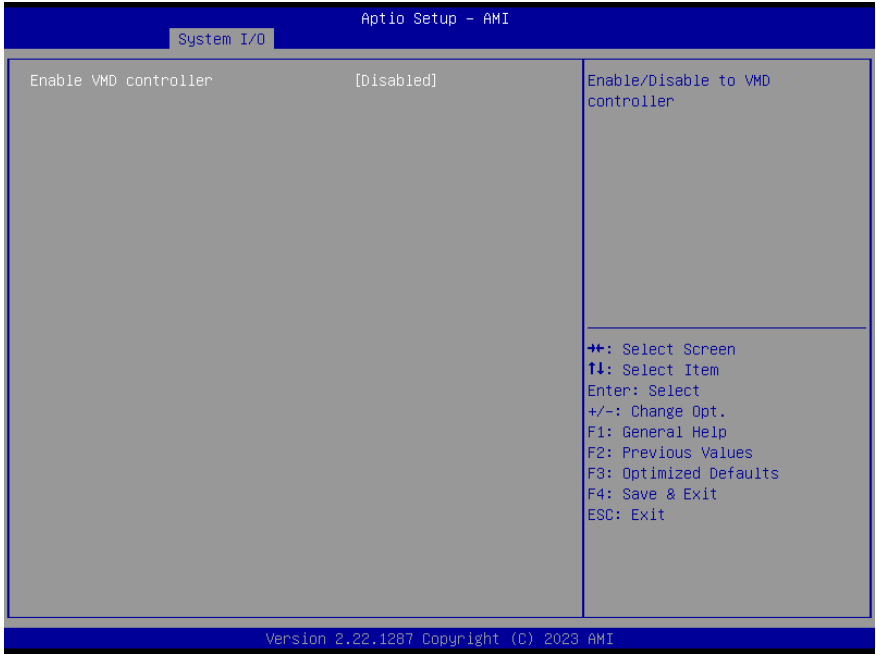

Options Summary		
Enable VMD controller	Disabled	Optimal Default, Failsafe Default
	Enabled	
Enable/Disable to VMD controller.		

3.5.4 NVMe Configuration

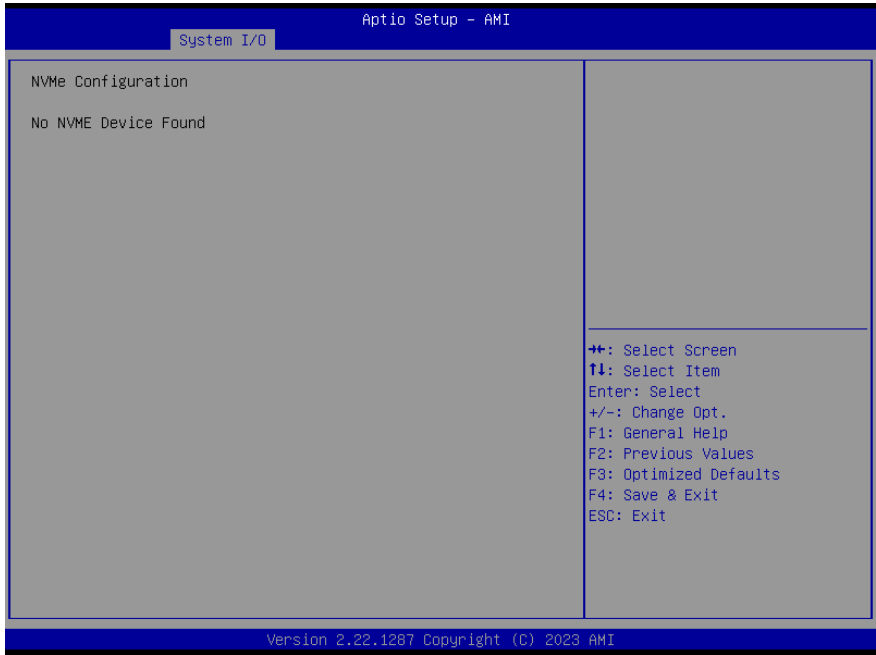

3.5.5 SATA Configuration

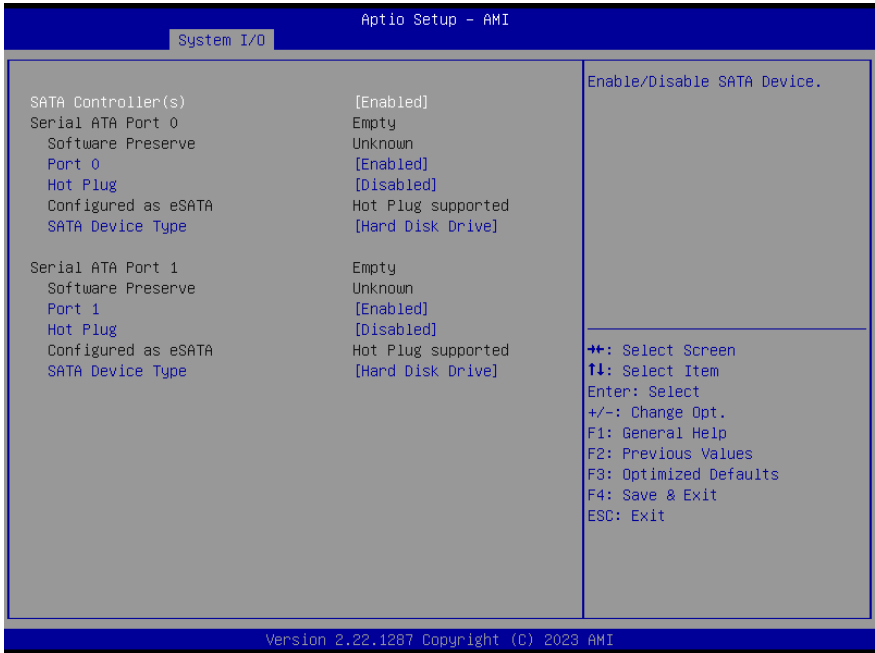

Options Summary		
SATA Controller(s)	Enabled	Optimal Default, Failsafe Default
	Disabled	
Enable/Disable SATA Device.		
Port 0	Disabled	
	Enabled	Optimal Default, Failsafe Default
Enable or Disable SATA Port.		
Hot Plug	Disabled	Optimal Default, Failsafe Default
	Enabled	
Designates this port as Hot Pluggable.		
SATA Device Type	Hard Disk Drive	Optimal Default, Failsafe Default
	Solid State Drive	
Identify the SATA port is connected to Solid State Drive or Hard Disk Drive.		
Port 1	Disabled	
	Enabled	Optimal Default, Failsafe Default
Enable or Disable SATA Port.		

Options Summary		
Hot Plug	Disabled	Optimal Default, Failsafe Default
	Enabled	
Designates this port as Hot Pluggable.		
SATA Device Type	Hard Disk Drive	Optimal Default, Failsafe Default
	Solid State Drive	
Identify the SATA port is connected to Solid State Drive or Hard Disk Drive.		

3.5.6 HD Audio Configuration

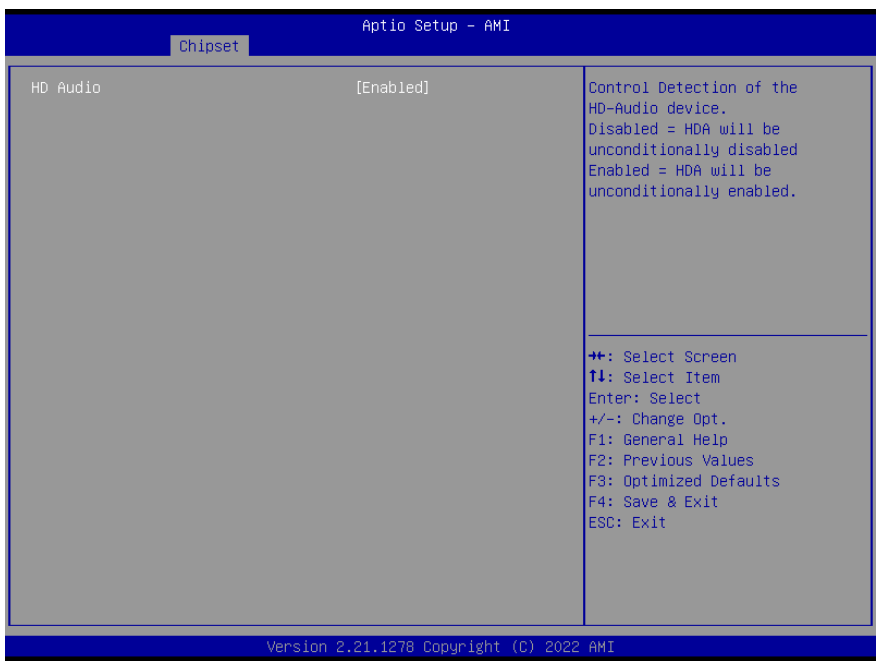

Options Summary		
HD Audio	Disabled	
	Enabled	Optimal Default, Failsafe Default
Control Detection of the HD-Audio device. Disabled = HDA will be unconditionally disabled. Enabled = HDA will be unconditionally enabled.		

3.5.7 Digital IO Port Configuration

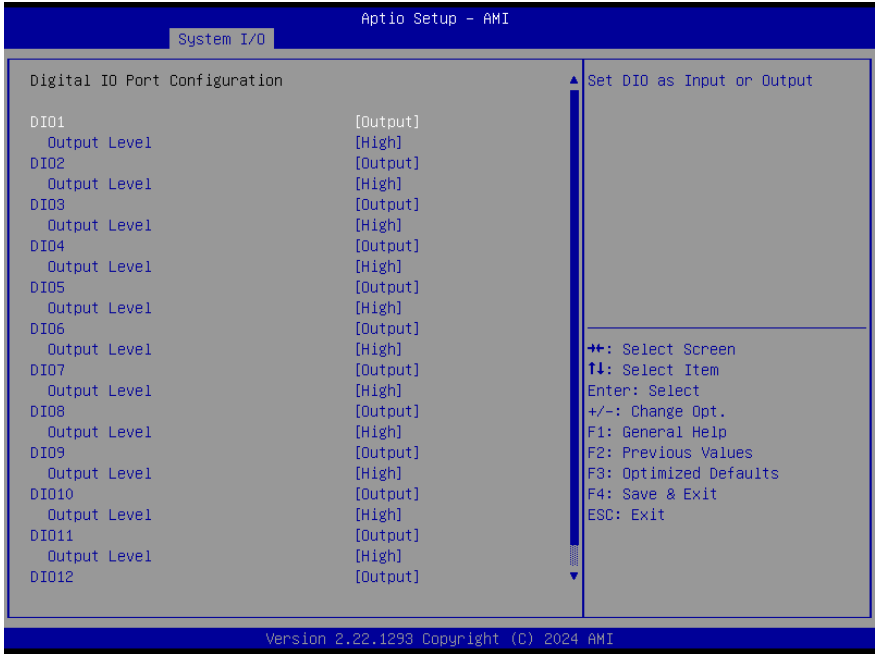

Options Summary		
DIO 1-12	Input	
	Output	Optimal Default, Failsafe Default
Set DIO as Input or Output.		
Output Level	Low	
	High	Optimal Default, Failsafe Default
Set output level when DIO pin is output.		

3.5.8 Legacy Logical Devices Configuration

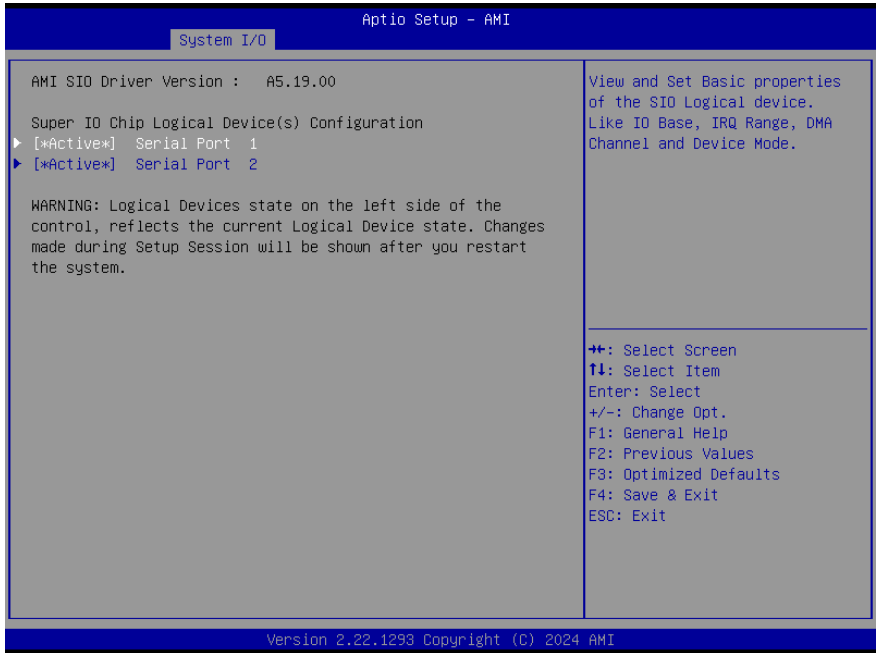

3.5.8.1 Serial Port 1 Configuration

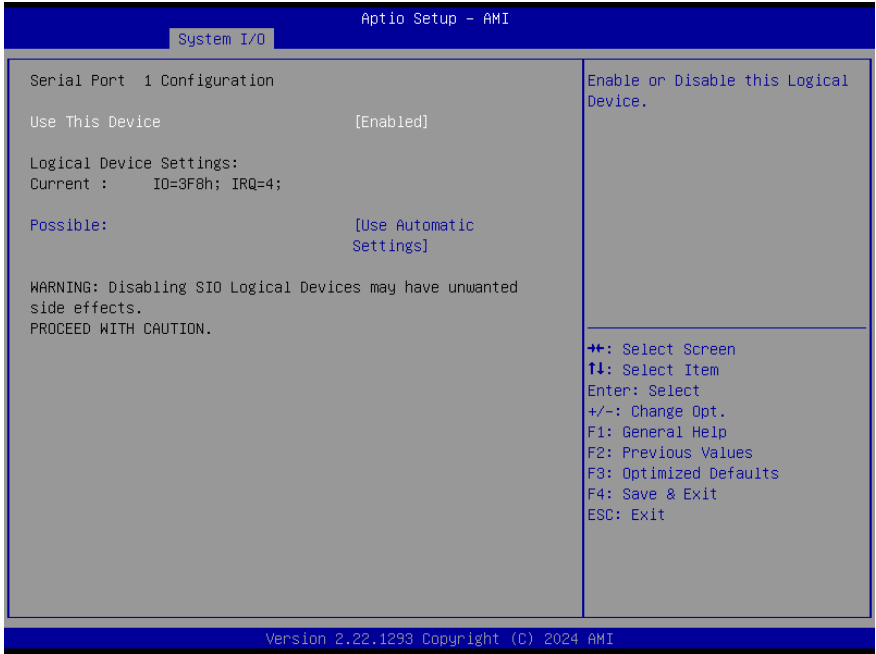

Options Summary		
Use This Device	Disabled	
	Enabled	Optimal Default, Failsafe Default
Enable or Disable this Logical Device.		
Possible:	Use Automatic Settings	Optimal Default, Failsafe Default
	IO=3F8h; IRQ=4; DMA;	
	IO=2C8h; IRQ=11; DMA;	
Allows the user to change the device resource settings. New settings will be reflected on this setup page after system restarts.		

3.5.8.2 Serial Port 2 Configuration

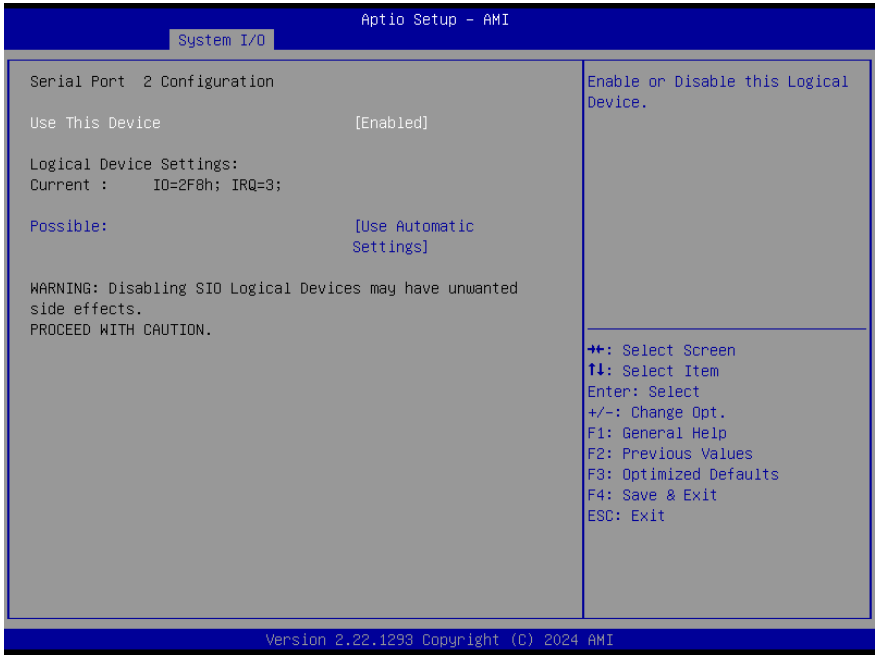

Options Summary		
Use This Device	Disabled	Optimal Default, Failsafe Default
	Enabled	
Enable or Disable this Logical Device.		
Possible:	Use Automatic Settings	Optimal Default, Failsafe Default
	IO=2F8h; IRQ=3 DMA;	
	IO=2D8h; IRQ=10; DMA;	
Allows the user to change the device resource settings. New settings will be reflected on this setup page after system restarts.		

3.5.9 Serial Port Console Redirection

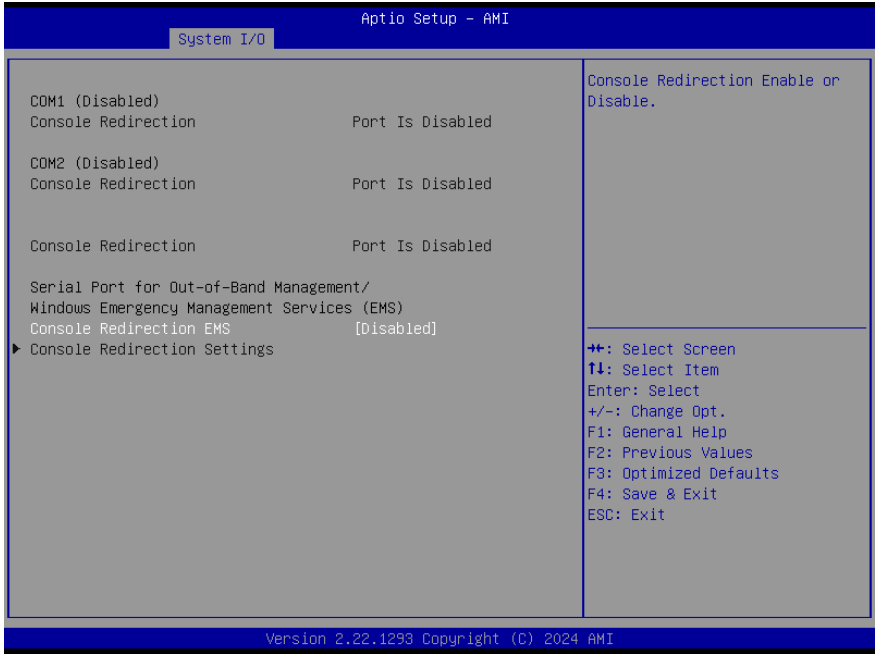

Options Summary		
Console Redirection	Disabled	Optimal Default, Failsafe Default
EMS	Enabled	
Console Redirection Enable or Disable.		

3.6 Setup Submenu: Security

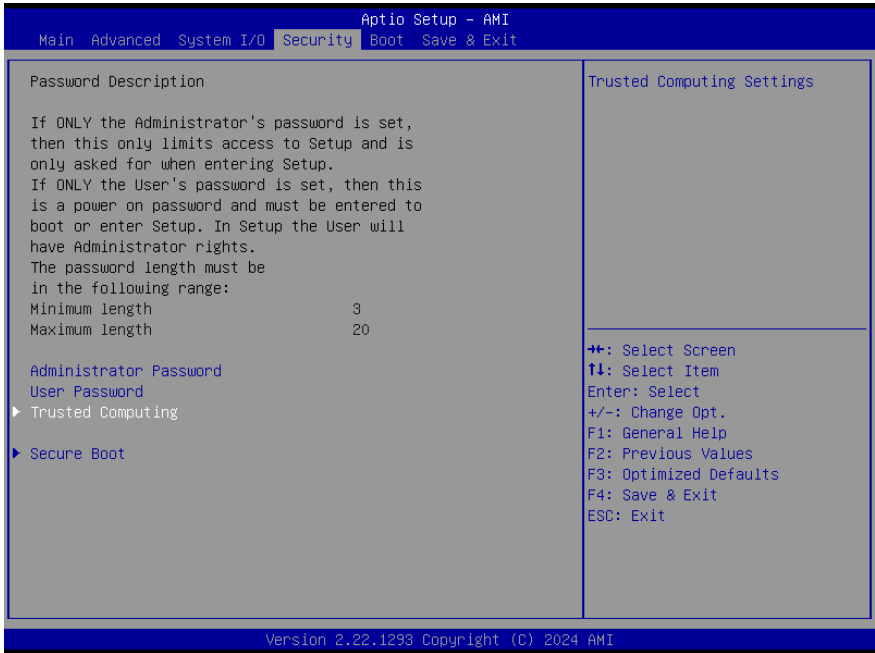

Change Administrator/User Password

You can set an Administrator password. If you set an Administrator password, you can then set a User password. User passwords do not have access to many of the features in the Setup utility.

Select the password you want to set and press <Enter>. A dialog box will appear which lets you set the password. Passwords must be between 3 and 20 letters or numbers. Press <Enter> and re-enter the password into the next dialog box that appears. Press <Enter> after you have retyped it correctly. The password is required at boot time, or when the user enters the Setup utility.

Remove Password

Highlight this item and type in the current password. At the next dialog box press <Enter> to disable password protection.

3.6.1 Secure Boot

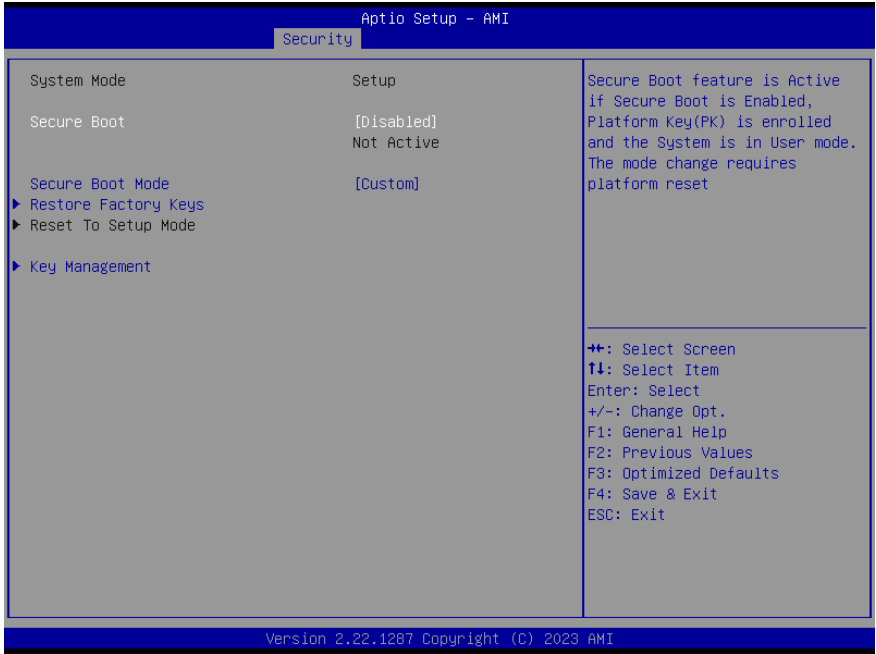

Options Summary		
Secure Boot	Disabled	Optimal Default, Failsafe Default
	Enabled	
Secure Boot feature is Active if Secure Boot is Enabled, Platform Key (PK) is enrolled and the System is in User mode. The mode change requires platform reset		
Secure Boot Mode	Standard	
	Custom	Optimal Default, Failsafe Default
Secure Boot mode options: Standard or Custom. In Custom mode, Secure Boot Policy variables can be configured by a physically present user without full authentication		

3.6.1.1 Key Management



Options Summary		
Factory Key Provision	Disabled	Optimal Default, Failsafe Default
	Enabled	
Install factory default Secure Boot keys after the platform reset and while the System is in Setup mode.		

3.6.2 Trusted Computing

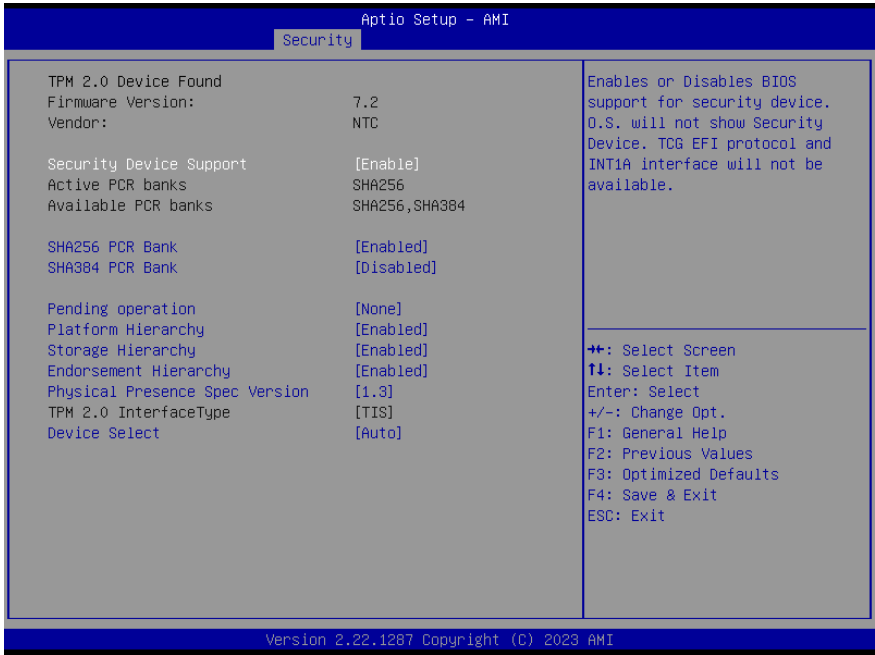

Options Summary		
Security Device Support	Disable	
	Enable	Optimal Default, Failsafe Default
Enables or Disables BIOS support for security device. O.S. will not show Security Device. TGU EFI protocol and INT1A interface will not be available.		
SHA 256 PCR Bank	Disabled	
	Enabled	Optimal Default, Failsafe Default
Enable or Disable SHA256 PCR Bank.		
SHA 384 PCR Bank	Disabled	Optimal Default, Failsafe Default
	Enabled	
Enable or Disable SHA384 PCR Bank.		
Pending operation	None	Optimal Default, Failsafe Default
	TPM Clear	

Options Summary		
Schedule an Operation for the Security Device. Note: Your Computer will reboot during restart in order to change State of Security Device.		
Platform Hierarchy	Disabled	
	Enabled	Optimal Default, Failsafe Default
Enable or Disable Platform Hierarchy.		
Storage Hierarchy	Disabled	
	Enabled	Optimal Default, Failsafe Default
Enable or Disable Storage Hierarchy.		
Endorsement Hierarchy	Disabled	
	Enabled	Optimal Default, Failsafe Default
Enable or Disable Endorsement Hierarchy.		
Physical Presence	1.2	
Spec Version	1.3	Optimal Default, Failsafe Default
Select to Tell O.S. to support PPI Spec Version 1.2 or 1.3. Note some HCK tests might not support 1.3.		
Device Select	TPM 1.2	
	TPM 2.0	
	Auto	Optimal Default, Failsafe Default
TPM 1.2 will restrict support to TPM 1.2 devices. TPM 2.0 will restrict support to TPM 2.0 Devices. Auto will support both with the default set to TPM 2.0 devices if not found. TPM 1.2 devices will be enumerated.		

3.7 Setup Submenu: Boot

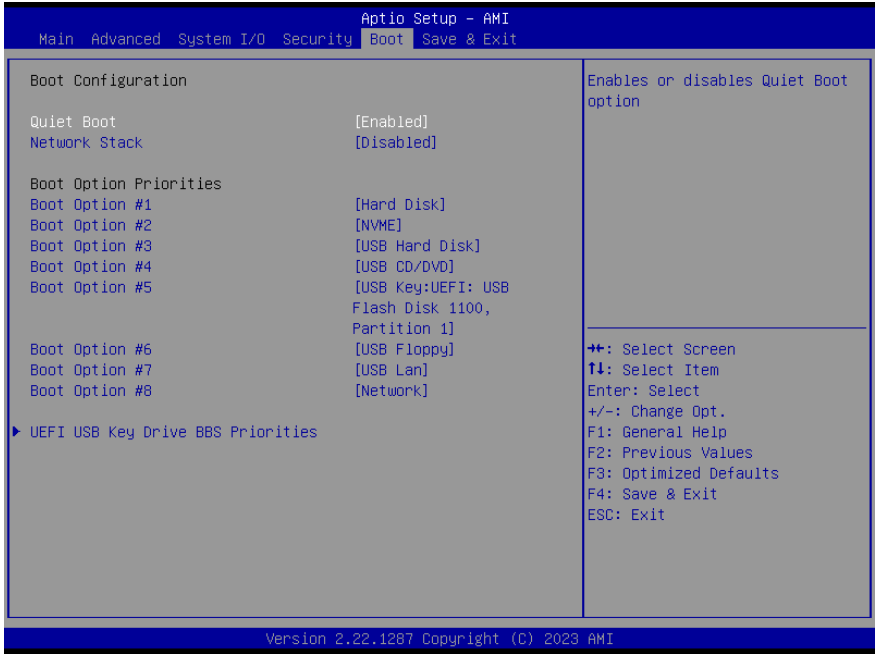

Options Summary		
Quiet Boot	Disabled	
	Enabled	Optimal Default, Failsafe Default
Enables or Disables Quite Boot option.		
Network Stack	Disabled	Optimal Default, Failsafe Default
	UEFI	
Enable/Disable UEFI Network Stack.		

3.8 Setup Submenu: Save & Exit

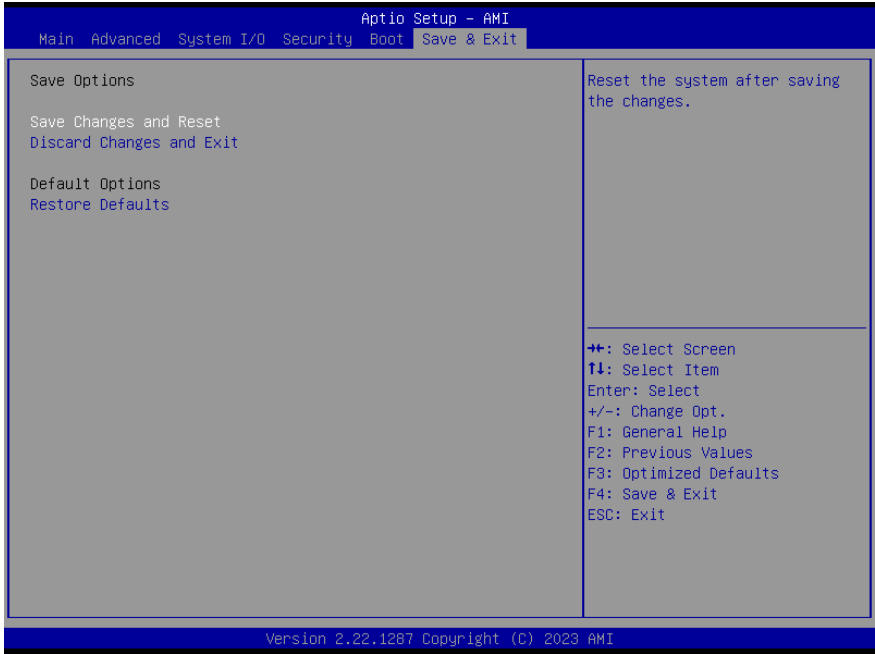

Chapter 4

Drivers Installation

4.1 Drivers Download and Installation

Drivers for the HPC-RPSC can be downloaded from the product page on the AAEON website by following this link:

<https://www.aaeon.com/en/product/detail/com-expresscpu-module-hpc-adsc-hpc-rpsc/download>

Download the driver(s) you need and follow the steps below to install them.

Chipset Driver

1. Open the folder where you unzipped the **Chipset Drivers**
2. Run the **SetupChipset.exe** file in the folder
3. Follow the instructions
4. Drivers will be installed automatically

Graphics Driver

1. Open the folder where you unzipped the **Graphics Drivers**
2. Run the **Installer.exe** file in the folder
3. Follow the instructions
4. Drivers will be installed automatically
5. Refer to the ReadMe.txt for any assistance.

LAN Drivers

1. Open the folder where you unzipped the **LAN Drivers**
2. Read the ReadMe.txt file before proceeding. **Caution:** Be sure to install the driver package before installing the Intel® PROSet package.
3. Open the **Wired_driver_26.8_x64** folder
4. Run the **Wired_driver_26.8_x64.exe** file in the folder
5. Follow the instructions, drivers will be installed automatically.
6. After installing the LAN driver, install Intel® PROSet package (optional)
7. Open the **Wired_PROSet_26.8_x64** folder
8. Run the **Wired_PROSet_26.8_x64.exe** file in the folder
9. Follow the instructions
10. Drivers will be installed automatically

Peripheral Driver (Linux)

1. Open the folder where you unzipped the **Peripheral Drivers**
2. Follow the instructions contained within the user guides to install the related drivers.

RAID Driver

1. Open the folder where you unzipped the **RAID Driver**
2. Run the **SetupRST.exe** file in the folder
3. Follow the instructions
4. Drivers will be installed automatically
5. Refer to the ReadMe.txt for any assistance.

Appendix A

I/O Information

A.1 I/O Address Map

Device Name	Address Range
Input/output (IO)	
PCI Express Root Complex	[0000000000000000 - 000000000000CF7]
Programmable interrupt controller	[0000000000000020 - 0000000000000021]
Programmable interrupt controller	[0000000000000024 - 0000000000000025]
Programmable interrupt controller	[0000000000000028 - 0000000000000029]
Programmable interrupt controller	[000000000000002C - 000000000000002D]
Motherboard resources	[000000000000002E - 000000000000002F]
Programmable interrupt controller	[0000000000000030 - 0000000000000031]
Programmable interrupt controller	[0000000000000034 - 0000000000000035]
Programmable interrupt controller	[0000000000000038 - 0000000000000039]
Programmable interrupt controller	[000000000000003C - 000000000000003D]
System timer	[0000000000000040 - 0000000000000043]
Motherboard resources	[000000000000004E - 000000000000004F]
System timer	[0000000000000050 - 0000000000000053]
Motherboard resources	[0000000000000061 - 0000000000000061]
Motherboard resources	[0000000000000063 - 0000000000000063]
Motherboard resources	[0000000000000065 - 0000000000000065]
Motherboard resources	[0000000000000067 - 0000000000000067]
Microsoft ACPI-Compliant Embedded Controller	[0000000000000068 - 0000000000000068]
Microsoft ACPI-Compliant Embedded Controller	[000000000000006C - 000000000000006C]
Motherboard resources	[0000000000000070 - 0000000000000070]
Motherboard resources	[0000000000000080 - 0000000000000080]
Motherboard resources	[0000000000000092 - 0000000000000092]
Programmable interrupt controller	[00000000000000A0 - 00000000000000A1]
Programmable interrupt controller	[00000000000000A4 - 00000000000000A5]
Programmable interrupt controller	[00000000000000A8 - 00000000000000A9]
Programmable interrupt controller	[00000000000000AC - 00000000000000AD]
Programmable interrupt controller	[00000000000000B0 - 00000000000000B1]
Motherboard resources	[00000000000000B2 - 00000000000000B3]
Programmable interrupt controller	[00000000000000B4 - 00000000000000B5]
Programmable interrupt controller	[00000000000000B8 - 00000000000000B9]
Programmable interrupt controller	[00000000000000BC - 00000000000000BD]
Numeric data processor	[00000000000000F0 - 00000000000000F0]
Communications Port (COM2)	[0000000000002F8 - 0000000000002FF]
Communications Port (COM1)	[0000000000003F8 - 0000000000003FF]
Programmable interrupt controller	[0000000000004D0 - 0000000000004D1]
Motherboard resources	[000000000000680 - 00000000000069F]
PCI Express Root Complex	[000000000000D00 - 000000000000FFFF]
Motherboard resources	[000000000000164E - 000000000000164F]
Motherboard resources	[0000000000001800 - 00000000000018FE]
Motherboard resources	[0000000000001854 - 0000000000001857]
Motherboard resources	[0000000000002000 - 00000000000020FE]
Intel(R) UHD Graphics	[0000000000003000 - 000000000000303F]
Standard SATA AHCI Controller	[0000000000003060 - 000000000000307F]
Standard SATA AHCI Controller	[0000000000003080 - 0000000000003083]
Standard SATA AHCI Controller	[0000000000003090 - 0000000000003097]
Intel(R) SMBus - 43A3	[000000000000EFA0 - 000000000000EFBF]
Intel(R) Active Management Technology - SOL (COM3)	[000000000000FFFB - 000000000000FFFF]

A.2 Memory Address Map



















































▼	Memory	
📁	[0000000000A0000 - 0000000000BFFFF]	PCI Express Root Complex
📁	[000000005040000 - 00000000504FFFF]	Intel(R) Ethernet Controller (3) I225-LM
📁	[000000005040000 - 00000000505FFFF]	Intel(R) PCI Express Root Port #9 - 43B0
📁	[000000005040000 - 00000000BFFFFFF]	PCI Express Root Complex
📁	[000000005050000 - 000000005053FFF]	Intel(R) Ethernet Controller (3) I225-LM
📁	[000000005060000 - 0000000050601FFF]	Standard SATA AHCI Controller
📁	[000000005060200 - 0000000050602FFF]	Standard SATA AHCI Controller
📁	[000000005060300 - 00000000506030FFF]	Standard SATA AHCI Controller
📁	[00000000BFFFFFF00 - 00000000BFFFFFFF]	Intel(R) Active Management Technology - SOL (COM3)
📁	[00000000C000000 - 00000000CFFFFFFF]	Motherboard resources
📁	[00000000FD00000 - 00000000FD68FFFF]	Motherboard resources
📁	[00000000FD69000 - 00000000FD69FFFF]	Intel(R) GPIO Controller - 34C6
📁	[00000000FD6A000 - 00000000FD6AFFFF]	Intel(R) GPIO Controller - 34C6
📁	[00000000FD6B000 - 00000000FD6BFFFF]	Intel(R) GPIO Controller - 34C6
📁	[00000000FD6C000 - 00000000FD6CFFFF]	Motherboard resources
📁	[00000000FD6D000 - 00000000FD6DFFFF]	Intel(R) GPIO Controller - 34C6
📁	[00000000FD6E000 - 00000000FD6EFFFF]	Intel(R) GPIO Controller - 34C6
📁	[00000000FD6F000 - 00000000FD6FFFFF]	Motherboard resources
📁	[00000000FE00000 - 00000000FE01FFFF]	Motherboard resources
📁	[00000000FE01000 - 00000000FE010FFF]	Intel(R) SPI (flash) Controller - 43A4
📁	[00000000FE04C00 - 00000000FE04FFFF]	Motherboard resources
📁	[00000000FE05000 - 00000000FE0AFFFF]	Motherboard resources
📁	[00000000FE0D000 - 00000000FE0FFFFF]	Motherboard resources
📁	[00000000FE20000 - 00000000FE7FFFFF]	Motherboard resources
📁	[00000000FED0000 - 00000000FED003FF]	High precision event timer
📁	[00000000FED2000 - 00000000FED7FFFF]	Motherboard resources
🔑	[00000000FED4000 - 00000000FED44FFF]	Trusted Platform Module 2.0
📁	[00000000FED4500 - 00000000FED8FFFF]	Motherboard resources
📁	[00000000FED9000 - 00000000FED93FFF]	Motherboard resources
📁	[00000000FEDA000 - 00000000FEDA0FFF]	Motherboard resources
📁	[00000000FEDA100 - 00000000FEDA1FFF]	Motherboard resources
📁	[00000000FEDC000 - 00000000FEDC7FFF]	Motherboard resources
📁	[00000000FEE0000 - 00000000FEEFFFFF]	Motherboard resources
📁	[00000000FF00000 - 00000000FFFFFFFF]	Motherboard resources
📁	[000000400000000 - 000000400FFFFFFF]	Intel(R) UHD Graphics
📁	[000000600000000 - 0000006000FFFFFFF]	Intel(R) UHD Graphics
🔌	[000000600110000 - 000000600110FFFF]	Intel(R) USB 3.2o eXtensible Host Controller - 1.20 (Microsoft)
📁	[000000600111000 - 0000006001117FFF]	Intel(R) Tigerlake Telemetry Aggregator Driver
📁	[000000600112000 - 00000060011200FF]	Intel(R) SMBus - 43A3
📁	[00000077FFEFB00 - 00000077FFEFBFFF]	Intel(R) Management Engine Interface #1
📁	[00000077FFFC000 - 00000077FFFCFFFF]	High Definition Audio Controller
📁	[00000077FFF0000 - 00000077FFF0FFFF]	High Definition Audio Controller



















































A.3 Large Memory Address Map



















































- ▼  Large Memory
 -  [0000004000000000 - 0000007FFFFFFFFF] PCI Express Root Complex



















































A.4 IRQ Mapping Chart



















































Interrupt request (IRQ)	
(ISA) 0x00000000 (00)	System timer
(ISA) 0x00000003 (03)	Communications Port (COM2)
(ISA) 0x00000004 (04)	Communications Port (COM1)
(ISA) 0x0000000D (13)	Numeric data processor
(ISA) 0x0000000E (14)	Intel(R) GPIO Controller - 34C6
(ISA) 0x0000001C (28)	Trusted Platform Module 2.0
(ISA) 0x00000037 (55)	Microsoft ACPI-Compliant System
(ISA) 0x00000038 (56)	Microsoft ACPI-Compliant System
(ISA) 0x00000039 (57)	Microsoft ACPI-Compliant System
(ISA) 0x0000003A (58)	Microsoft ACPI-Compliant System
(ISA) 0x0000003B (59)	Microsoft ACPI-Compliant System
(ISA) 0x0000003C (60)	Microsoft ACPI-Compliant System
(ISA) 0x0000003D (61)	Microsoft ACPI-Compliant System
(ISA) 0x0000003E (62)	Microsoft ACPI-Compliant System
(ISA) 0x0000003F (63)	Microsoft ACPI-Compliant System
(ISA) 0x00000040 (64)	Microsoft ACPI-Compliant System
(ISA) 0x00000041 (65)	Microsoft ACPI-Compliant System
(ISA) 0x00000042 (66)	Microsoft ACPI-Compliant System
(ISA) 0x00000043 (67)	Microsoft ACPI-Compliant System
(ISA) 0x00000044 (68)	Microsoft ACPI-Compliant System
(ISA) 0x00000045 (69)	Microsoft ACPI-Compliant System
(ISA) 0x00000046 (70)	Microsoft ACPI-Compliant System
(ISA) 0x00000047 (71)	Microsoft ACPI-Compliant System
(ISA) 0x00000048 (72)	Microsoft ACPI-Compliant System
(ISA) 0x00000049 (73)	Microsoft ACPI-Compliant System
(ISA) 0x0000004A (74)	Microsoft ACPI-Compliant System
(ISA) 0x0000004B (75)	Microsoft ACPI-Compliant System
(ISA) 0x0000004C (76)	Microsoft ACPI-Compliant System
(ISA) 0x0000004D (77)	Microsoft ACPI-Compliant System
(ISA) 0x0000004E (78)	Microsoft ACPI-Compliant System
(ISA) 0x0000004F (79)	Microsoft ACPI-Compliant System
(ISA) 0x00000050 (80)	Microsoft ACPI-Compliant System
(ISA) 0x00000051 (81)	Microsoft ACPI-Compliant System
(ISA) 0x00000052 (82)	Microsoft ACPI-Compliant System
(ISA) 0x00000053 (83)	Microsoft ACPI-Compliant System
(ISA) 0x00000054 (84)	Microsoft ACPI-Compliant System
(ISA) 0x00000055 (85)	Microsoft ACPI-Compliant System
(ISA) 0x00000056 (86)	Microsoft ACPI-Compliant System
(ISA) 0x00000057 (87)	Microsoft ACPI-Compliant System
(ISA) 0x00000058 (88)	Microsoft ACPI-Compliant System
(ISA) 0x00000059 (89)	Microsoft ACPI-Compliant System
(ISA) 0x0000005A (90)	Microsoft ACPI-Compliant System
(ISA) 0x0000005B (91)	Microsoft ACPI-Compliant System
(ISA) 0x0000005C (92)	Microsoft ACPI-Compliant System
(ISA) 0x0000005D (93)	Microsoft ACPI-Compliant System
(ISA) 0x0000005E (94)	Microsoft ACPI-Compliant System
(ISA) 0x0000005F (95)	Microsoft ACPI-Compliant System
(ISA) 0x00000060 (96)	Microsoft ACPI-Compliant System
(ISA) 0x00000061 (97)	Microsoft ACPI-Compliant System
(ISA) 0x00000062 (98)	Microsoft ACPI-Compliant System



















































 (ISA) 0x00000062 (98)	Microsoft ACPI-Compliant System
 (ISA) 0x00000063 (99)	Microsoft ACPI-Compliant System
 (ISA) 0x00000064 (100)	Microsoft ACPI-Compliant System
 (ISA) 0x00000065 (101)	Microsoft ACPI-Compliant System
 (ISA) 0x00000066 (102)	Microsoft ACPI-Compliant System
 (ISA) 0x00000067 (103)	Microsoft ACPI-Compliant System
 (ISA) 0x00000068 (104)	Microsoft ACPI-Compliant System
 (ISA) 0x00000069 (105)	Microsoft ACPI-Compliant System
 (ISA) 0x0000006A (106)	Microsoft ACPI-Compliant System
 (ISA) 0x0000006B (107)	Microsoft ACPI-Compliant System
 (ISA) 0x0000006C (108)	Microsoft ACPI-Compliant System
 (ISA) 0x0000006D (109)	Microsoft ACPI-Compliant System
 (ISA) 0x0000006E (110)	Microsoft ACPI-Compliant System
 (ISA) 0x0000006F (111)	Microsoft ACPI-Compliant System
 (ISA) 0x00000070 (112)	Microsoft ACPI-Compliant System
 (ISA) 0x00000071 (113)	Microsoft ACPI-Compliant System
 (ISA) 0x00000072 (114)	Microsoft ACPI-Compliant System
 (ISA) 0x00000073 (115)	Microsoft ACPI-Compliant System
 (ISA) 0x00000074 (116)	Microsoft ACPI-Compliant System
 (ISA) 0x00000075 (117)	Microsoft ACPI-Compliant System
 (ISA) 0x00000076 (118)	Microsoft ACPI-Compliant System
 (ISA) 0x00000077 (119)	Microsoft ACPI-Compliant System
 (ISA) 0x00000078 (120)	Microsoft ACPI-Compliant System
 (ISA) 0x00000079 (121)	Microsoft ACPI-Compliant System
 (ISA) 0x0000007A (122)	Microsoft ACPI-Compliant System
 (ISA) 0x0000007B (123)	Microsoft ACPI-Compliant System
 (ISA) 0x0000007C (124)	Microsoft ACPI-Compliant System
 (ISA) 0x0000007D (125)	Microsoft ACPI-Compliant System
 (ISA) 0x0000007E (126)	Microsoft ACPI-Compliant System
 (ISA) 0x0000007F (127)	Microsoft ACPI-Compliant System
 (ISA) 0x00000080 (128)	Microsoft ACPI-Compliant System
 (ISA) 0x00000081 (129)	Microsoft ACPI-Compliant System
 (ISA) 0x00000082 (130)	Microsoft ACPI-Compliant System
 (ISA) 0x00000083 (131)	Microsoft ACPI-Compliant System
 (ISA) 0x00000084 (132)	Microsoft ACPI-Compliant System
 (ISA) 0x00000085 (133)	Microsoft ACPI-Compliant System
 (ISA) 0x00000086 (134)	Microsoft ACPI-Compliant System
 (ISA) 0x00000087 (135)	Microsoft ACPI-Compliant System
 (ISA) 0x00000088 (136)	Microsoft ACPI-Compliant System
 (ISA) 0x00000089 (137)	Microsoft ACPI-Compliant System
 (ISA) 0x0000008A (138)	Microsoft ACPI-Compliant System
 (ISA) 0x0000008B (139)	Microsoft ACPI-Compliant System
 (ISA) 0x0000008C (140)	Microsoft ACPI-Compliant System
 (ISA) 0x0000008D (141)	Microsoft ACPI-Compliant System
 (ISA) 0x0000008E (142)	Microsoft ACPI-Compliant System
 (ISA) 0x0000008F (143)	Microsoft ACPI-Compliant System
 (ISA) 0x00000090 (144)	Microsoft ACPI-Compliant System
 (ISA) 0x00000091 (145)	Microsoft ACPI-Compliant System
 (ISA) 0x00000092 (146)	Microsoft ACPI-Compliant System
 (ISA) 0x00000093 (147)	Microsoft ACPI-Compliant System
 (ISA) 0x00000094 (148)	Microsoft ACPI-Compliant System



















































 (ISA) 0x00000095 (149)	Microsoft ACPI-Compliant System
 (ISA) 0x00000096 (150)	Microsoft ACPI-Compliant System
 (ISA) 0x00000097 (151)	Microsoft ACPI-Compliant System
 (ISA) 0x00000098 (152)	Microsoft ACPI-Compliant System
 (ISA) 0x00000099 (153)	Microsoft ACPI-Compliant System
 (ISA) 0x0000009A (154)	Microsoft ACPI-Compliant System
 (ISA) 0x0000009B (155)	Microsoft ACPI-Compliant System
 (ISA) 0x0000009C (156)	Microsoft ACPI-Compliant System
 (ISA) 0x0000009D (157)	Microsoft ACPI-Compliant System
 (ISA) 0x0000009E (158)	Microsoft ACPI-Compliant System
 (ISA) 0x0000009F (159)	Microsoft ACPI-Compliant System
 (ISA) 0x000000A0 (160)	Microsoft ACPI-Compliant System
 (ISA) 0x000000A1 (161)	Microsoft ACPI-Compliant System
 (ISA) 0x000000A2 (162)	Microsoft ACPI-Compliant System
 (ISA) 0x000000A3 (163)	Microsoft ACPI-Compliant System
 (ISA) 0x000000A4 (164)	Microsoft ACPI-Compliant System
 (ISA) 0x000000A5 (165)	Microsoft ACPI-Compliant System
 (ISA) 0x000000A6 (166)	Microsoft ACPI-Compliant System
 (ISA) 0x000000A7 (167)	Microsoft ACPI-Compliant System
 (ISA) 0x000000A8 (168)	Microsoft ACPI-Compliant System
 (ISA) 0x000000A9 (169)	Microsoft ACPI-Compliant System
 (ISA) 0x000000AA (170)	Microsoft ACPI-Compliant System
 (ISA) 0x000000AB (171)	Microsoft ACPI-Compliant System
 (ISA) 0x000000AC (172)	Microsoft ACPI-Compliant System
 (ISA) 0x000000AD (173)	Microsoft ACPI-Compliant System
 (ISA) 0x000000AE (174)	Microsoft ACPI-Compliant System
 (ISA) 0x000000AF (175)	Microsoft ACPI-Compliant System
 (ISA) 0x000000B0 (176)	Microsoft ACPI-Compliant System
 (ISA) 0x000000B1 (177)	Microsoft ACPI-Compliant System
 (ISA) 0x000000B2 (178)	Microsoft ACPI-Compliant System
 (ISA) 0x000000B3 (179)	Microsoft ACPI-Compliant System
 (ISA) 0x000000B4 (180)	Microsoft ACPI-Compliant System
 (ISA) 0x000000B5 (181)	Microsoft ACPI-Compliant System
 (ISA) 0x000000B6 (182)	Microsoft ACPI-Compliant System
 (ISA) 0x000000B7 (183)	Microsoft ACPI-Compliant System
 (ISA) 0x000000B8 (184)	Microsoft ACPI-Compliant System
 (ISA) 0x000000B9 (185)	Microsoft ACPI-Compliant System
 (ISA) 0x000000BA (186)	Microsoft ACPI-Compliant System
 (ISA) 0x000000BB (187)	Microsoft ACPI-Compliant System
 (ISA) 0x000000BC (188)	Microsoft ACPI-Compliant System
 (ISA) 0x000000BD (189)	Microsoft ACPI-Compliant System
 (ISA) 0x000000BE (190)	Microsoft ACPI-Compliant System
 (ISA) 0x000000BF (191)	Microsoft ACPI-Compliant System
 (ISA) 0x000000C0 (192)	Microsoft ACPI-Compliant System
 (ISA) 0x000000C1 (193)	Microsoft ACPI-Compliant System
 (ISA) 0x000000C2 (194)	Microsoft ACPI-Compliant System
 (ISA) 0x000000C3 (195)	Microsoft ACPI-Compliant System
 (ISA) 0x000000C4 (196)	Microsoft ACPI-Compliant System
 (ISA) 0x000000C5 (197)	Microsoft ACPI-Compliant System
 (ISA) 0x000000C6 (198)	Microsoft ACPI-Compliant System
 (ISA) 0x000000C7 (199)	Microsoft ACPI-Compliant System



















 (ISA) 0x000000C8 (200)	Microsoft ACPI-Compliant System
 (ISA) 0x000000C9 (201)	Microsoft ACPI-Compliant System
 (ISA) 0x000000CA (202)	Microsoft ACPI-Compliant System
 (ISA) 0x000000CB (203)	Microsoft ACPI-Compliant System
 (ISA) 0x000000CC (204)	Microsoft ACPI-Compliant System
 (ISA) 0x00000100 (256)	Microsoft ACPI-Compliant System
 (ISA) 0x00000101 (257)	Microsoft ACPI-Compliant System
 (ISA) 0x00000102 (258)	Microsoft ACPI-Compliant System
 (ISA) 0x00000103 (259)	Microsoft ACPI-Compliant System
 (ISA) 0x00000104 (260)	Microsoft ACPI-Compliant System
 (ISA) 0x00000105 (261)	Microsoft ACPI-Compliant System
 (ISA) 0x00000106 (262)	Microsoft ACPI-Compliant System
 (ISA) 0x00000107 (263)	Microsoft ACPI-Compliant System
 (ISA) 0x00000108 (264)	Microsoft ACPI-Compliant System
 (ISA) 0x00000109 (265)	Microsoft ACPI-Compliant System
 (ISA) 0x0000010A (266)	Microsoft ACPI-Compliant System
 (ISA) 0x0000010B (267)	Microsoft ACPI-Compliant System
 (ISA) 0x0000010C (268)	Microsoft ACPI-Compliant System
 (ISA) 0x0000010D (269)	Microsoft ACPI-Compliant System
 (ISA) 0x0000010E (270)	Microsoft ACPI-Compliant System
 (ISA) 0x0000010F (271)	Microsoft ACPI-Compliant System
 (ISA) 0x00000110 (272)	Microsoft ACPI-Compliant System
 (ISA) 0x00000111 (273)	Microsoft ACPI-Compliant System
 (ISA) 0x00000112 (274)	Microsoft ACPI-Compliant System
 (ISA) 0x00000113 (275)	Microsoft ACPI-Compliant System
 (ISA) 0x00000114 (276)	Microsoft ACPI-Compliant System
 (ISA) 0x00000115 (277)	Microsoft ACPI-Compliant System
 (ISA) 0x00000116 (278)	Microsoft ACPI-Compliant System
 (ISA) 0x00000117 (279)	Microsoft ACPI-Compliant System
 (ISA) 0x00000118 (280)	Microsoft ACPI-Compliant System
 (ISA) 0x00000119 (281)	Microsoft ACPI-Compliant System
 (ISA) 0x0000011A (282)	Microsoft ACPI-Compliant System
 (ISA) 0x0000011B (283)	Microsoft ACPI-Compliant System
 (ISA) 0x0000011C (284)	Microsoft ACPI-Compliant System
 (ISA) 0x0000011D (285)	Microsoft ACPI-Compliant System
 (ISA) 0x0000011E (286)	Microsoft ACPI-Compliant System
 (ISA) 0x0000011F (287)	Microsoft ACPI-Compliant System
 (ISA) 0x00000120 (288)	Microsoft ACPI-Compliant System
 (ISA) 0x00000121 (289)	Microsoft ACPI-Compliant System
 (ISA) 0x00000122 (290)	Microsoft ACPI-Compliant System
 (ISA) 0x00000123 (291)	Microsoft ACPI-Compliant System
 (ISA) 0x00000124 (292)	Microsoft ACPI-Compliant System
 (ISA) 0x00000125 (293)	Microsoft ACPI-Compliant System
 (ISA) 0x00000126 (294)	Microsoft ACPI-Compliant System
 (ISA) 0x00000127 (295)	Microsoft ACPI-Compliant System
 (ISA) 0x00000128 (296)	Microsoft ACPI-Compliant System
 (ISA) 0x00000129 (297)	Microsoft ACPI-Compliant System
 (ISA) 0x0000012A (298)	Microsoft ACPI-Compliant System
 (ISA) 0x0000012B (299)	Microsoft ACPI-Compliant System
 (ISA) 0x0000012C (300)	Microsoft ACPI-Compliant System
 (ISA) 0x0000012D (301)	Microsoft ACPI-Compliant System

 (ISA) 0x0000012E (302)	Microsoft ACPI-Compliant System
 (ISA) 0x0000012F (303)	Microsoft ACPI-Compliant System
 (ISA) 0x00000130 (304)	Microsoft ACPI-Compliant System
 (ISA) 0x00000131 (305)	Microsoft ACPI-Compliant System
 (ISA) 0x00000132 (306)	Microsoft ACPI-Compliant System
 (ISA) 0x00000133 (307)	Microsoft ACPI-Compliant System
 (ISA) 0x00000134 (308)	Microsoft ACPI-Compliant System
 (ISA) 0x00000135 (309)	Microsoft ACPI-Compliant System
 (ISA) 0x00000136 (310)	Microsoft ACPI-Compliant System
 (ISA) 0x00000137 (311)	Microsoft ACPI-Compliant System
 (ISA) 0x00000138 (312)	Microsoft ACPI-Compliant System
 (ISA) 0x00000139 (313)	Microsoft ACPI-Compliant System
 (ISA) 0x0000013A (314)	Microsoft ACPI-Compliant System
 (ISA) 0x0000013B (315)	Microsoft ACPI-Compliant System
 (ISA) 0x0000013C (316)	Microsoft ACPI-Compliant System
 (ISA) 0x0000013D (317)	Microsoft ACPI-Compliant System
 (ISA) 0x0000013E (318)	Microsoft ACPI-Compliant System
 (ISA) 0x0000013F (319)	Microsoft ACPI-Compliant System
 (ISA) 0x00000140 (320)	Microsoft ACPI-Compliant System
 (ISA) 0x00000141 (321)	Microsoft ACPI-Compliant System
 (ISA) 0x00000142 (322)	Microsoft ACPI-Compliant System
 (ISA) 0x00000143 (323)	Microsoft ACPI-Compliant System
 (ISA) 0x00000144 (324)	Microsoft ACPI-Compliant System
 (ISA) 0x00000145 (325)	Microsoft ACPI-Compliant System
 (ISA) 0x00000146 (326)	Microsoft ACPI-Compliant System
 (ISA) 0x00000147 (327)	Microsoft ACPI-Compliant System
 (ISA) 0x00000148 (328)	Microsoft ACPI-Compliant System
 (ISA) 0x00000149 (329)	Microsoft ACPI-Compliant System
 (ISA) 0x0000014A (330)	Microsoft ACPI-Compliant System
 (ISA) 0x0000014B (331)	Microsoft ACPI-Compliant System
 (ISA) 0x0000014C (332)	Microsoft ACPI-Compliant System
 (ISA) 0x0000014D (333)	Microsoft ACPI-Compliant System
 (ISA) 0x0000014E (334)	Microsoft ACPI-Compliant System
 (ISA) 0x0000014F (335)	Microsoft ACPI-Compliant System
 (ISA) 0x00000150 (336)	Microsoft ACPI-Compliant System
 (ISA) 0x00000151 (337)	Microsoft ACPI-Compliant System
 (ISA) 0x00000152 (338)	Microsoft ACPI-Compliant System
 (ISA) 0x00000153 (339)	Microsoft ACPI-Compliant System
 (ISA) 0x00000154 (340)	Microsoft ACPI-Compliant System
 (ISA) 0x00000155 (341)	Microsoft ACPI-Compliant System
 (ISA) 0x00000156 (342)	Microsoft ACPI-Compliant System
 (ISA) 0x00000157 (343)	Microsoft ACPI-Compliant System
 (ISA) 0x00000158 (344)	Microsoft ACPI-Compliant System
 (ISA) 0x00000159 (345)	Microsoft ACPI-Compliant System
 (ISA) 0x0000015A (346)	Microsoft ACPI-Compliant System
 (ISA) 0x0000015B (347)	Microsoft ACPI-Compliant System
 (ISA) 0x0000015C (348)	Microsoft ACPI-Compliant System
 (ISA) 0x0000015D (349)	Microsoft ACPI-Compliant System
 (ISA) 0x0000015E (350)	Microsoft ACPI-Compliant System
 (ISA) 0x0000015F (351)	Microsoft ACPI-Compliant System
 (ISA) 0x00000160 (352)	Microsoft ACPI-Compliant System

 (ISA) 0x00000161 (353)	Microsoft ACPI-Compliant System
 (ISA) 0x00000162 (354)	Microsoft ACPI-Compliant System
 (ISA) 0x00000163 (355)	Microsoft ACPI-Compliant System
 (ISA) 0x00000164 (356)	Microsoft ACPI-Compliant System
 (ISA) 0x00000165 (357)	Microsoft ACPI-Compliant System
 (ISA) 0x00000166 (358)	Microsoft ACPI-Compliant System
 (ISA) 0x00000167 (359)	Microsoft ACPI-Compliant System
 (ISA) 0x00000168 (360)	Microsoft ACPI-Compliant System
 (ISA) 0x00000169 (361)	Microsoft ACPI-Compliant System
 (ISA) 0x0000016A (362)	Microsoft ACPI-Compliant System
 (ISA) 0x0000016B (363)	Microsoft ACPI-Compliant System
 (ISA) 0x0000016C (364)	Microsoft ACPI-Compliant System
 (ISA) 0x0000016D (365)	Microsoft ACPI-Compliant System
 (ISA) 0x0000016E (366)	Microsoft ACPI-Compliant System
 (ISA) 0x0000016F (367)	Microsoft ACPI-Compliant System
 (ISA) 0x00000170 (368)	Microsoft ACPI-Compliant System
 (ISA) 0x00000171 (369)	Microsoft ACPI-Compliant System
 (ISA) 0x00000172 (370)	Microsoft ACPI-Compliant System
 (ISA) 0x00000173 (371)	Microsoft ACPI-Compliant System
 (ISA) 0x00000174 (372)	Microsoft ACPI-Compliant System
 (ISA) 0x00000175 (373)	Microsoft ACPI-Compliant System
 (ISA) 0x00000176 (374)	Microsoft ACPI-Compliant System
 (ISA) 0x00000177 (375)	Microsoft ACPI-Compliant System
 (ISA) 0x00000178 (376)	Microsoft ACPI-Compliant System
 (ISA) 0x00000179 (377)	Microsoft ACPI-Compliant System
 (ISA) 0x0000017A (378)	Microsoft ACPI-Compliant System
 (ISA) 0x0000017B (379)	Microsoft ACPI-Compliant System
 (ISA) 0x0000017C (380)	Microsoft ACPI-Compliant System
 (ISA) 0x0000017D (381)	Microsoft ACPI-Compliant System
 (ISA) 0x0000017E (382)	Microsoft ACPI-Compliant System
 (ISA) 0x0000017F (383)	Microsoft ACPI-Compliant System
 (ISA) 0x00000180 (384)	Microsoft ACPI-Compliant System
 (ISA) 0x00000181 (385)	Microsoft ACPI-Compliant System
 (ISA) 0x00000182 (386)	Microsoft ACPI-Compliant System
 (ISA) 0x00000183 (387)	Microsoft ACPI-Compliant System
 (ISA) 0x00000184 (388)	Microsoft ACPI-Compliant System
 (ISA) 0x00000185 (389)	Microsoft ACPI-Compliant System
 (ISA) 0x00000186 (390)	Microsoft ACPI-Compliant System
 (ISA) 0x00000187 (391)	Microsoft ACPI-Compliant System
 (ISA) 0x00000188 (392)	Microsoft ACPI-Compliant System
 (ISA) 0x00000189 (393)	Microsoft ACPI-Compliant System
 (ISA) 0x0000018A (394)	Microsoft ACPI-Compliant System
 (ISA) 0x0000018B (395)	Microsoft ACPI-Compliant System
 (ISA) 0x0000018C (396)	Microsoft ACPI-Compliant System
 (ISA) 0x0000018D (397)	Microsoft ACPI-Compliant System
 (ISA) 0x0000018E (398)	Microsoft ACPI-Compliant System
 (ISA) 0x0000018F (399)	Microsoft ACPI-Compliant System
 (ISA) 0x00000190 (400)	Microsoft ACPI-Compliant System
 (ISA) 0x00000191 (401)	Microsoft ACPI-Compliant System
 (ISA) 0x00000192 (402)	Microsoft ACPI-Compliant System
 (ISA) 0x00000193 (403)	Microsoft ACPI-Compliant System

 (ISA) 0x00000194 (404)	Microsoft ACPI-Compliant System
 (ISA) 0x00000195 (405)	Microsoft ACPI-Compliant System
 (ISA) 0x00000196 (406)	Microsoft ACPI-Compliant System
 (ISA) 0x00000197 (407)	Microsoft ACPI-Compliant System
 (ISA) 0x00000198 (408)	Microsoft ACPI-Compliant System
 (ISA) 0x00000199 (409)	Microsoft ACPI-Compliant System
 (ISA) 0x0000019A (410)	Microsoft ACPI-Compliant System
 (ISA) 0x0000019B (411)	Microsoft ACPI-Compliant System
 (ISA) 0x0000019C (412)	Microsoft ACPI-Compliant System
 (ISA) 0x0000019D (413)	Microsoft ACPI-Compliant System
 (ISA) 0x0000019E (414)	Microsoft ACPI-Compliant System
 (ISA) 0x0000019F (415)	Microsoft ACPI-Compliant System
 (ISA) 0x000001A0 (416)	Microsoft ACPI-Compliant System
 (ISA) 0x000001A1 (417)	Microsoft ACPI-Compliant System
 (ISA) 0x000001A2 (418)	Microsoft ACPI-Compliant System
 (ISA) 0x000001A3 (419)	Microsoft ACPI-Compliant System
 (ISA) 0x000001A4 (420)	Microsoft ACPI-Compliant System
 (ISA) 0x000001A5 (421)	Microsoft ACPI-Compliant System
 (ISA) 0x000001A6 (422)	Microsoft ACPI-Compliant System
 (ISA) 0x000001A7 (423)	Microsoft ACPI-Compliant System
 (ISA) 0x000001A8 (424)	Microsoft ACPI-Compliant System
 (ISA) 0x000001A9 (425)	Microsoft ACPI-Compliant System
 (ISA) 0x000001AA (426)	Microsoft ACPI-Compliant System
 (ISA) 0x000001AB (427)	Microsoft ACPI-Compliant System
 (ISA) 0x000001AC (428)	Microsoft ACPI-Compliant System
 (ISA) 0x000001AD (429)	Microsoft ACPI-Compliant System
 (ISA) 0x000001AE (430)	Microsoft ACPI-Compliant System
 (ISA) 0x000001AF (431)	Microsoft ACPI-Compliant System
 (ISA) 0x000001B0 (432)	Microsoft ACPI-Compliant System
 (ISA) 0x000001B1 (433)	Microsoft ACPI-Compliant System
 (ISA) 0x000001B2 (434)	Microsoft ACPI-Compliant System
 (ISA) 0x000001B3 (435)	Microsoft ACPI-Compliant System
 (ISA) 0x000001B4 (436)	Microsoft ACPI-Compliant System
 (ISA) 0x000001B5 (437)	Microsoft ACPI-Compliant System
 (ISA) 0x000001B6 (438)	Microsoft ACPI-Compliant System
 (ISA) 0x000001B7 (439)	Microsoft ACPI-Compliant System
 (ISA) 0x000001B8 (440)	Microsoft ACPI-Compliant System
 (ISA) 0x000001B9 (441)	Microsoft ACPI-Compliant System
 (ISA) 0x000001BA (442)	Microsoft ACPI-Compliant System
 (ISA) 0x000001BB (443)	Microsoft ACPI-Compliant System
 (ISA) 0x000001BC (444)	Microsoft ACPI-Compliant System
 (ISA) 0x000001BD (445)	Microsoft ACPI-Compliant System
 (ISA) 0x000001BE (446)	Microsoft ACPI-Compliant System
 (ISA) 0x000001BF (447)	Microsoft ACPI-Compliant System
 (ISA) 0x000001C0 (448)	Microsoft ACPI-Compliant System
 (ISA) 0x000001C1 (449)	Microsoft ACPI-Compliant System
 (ISA) 0x000001C2 (450)	Microsoft ACPI-Compliant System
 (ISA) 0x000001C3 (451)	Microsoft ACPI-Compliant System
 (ISA) 0x000001C4 (452)	Microsoft ACPI-Compliant System
 (ISA) 0x000001C5 (453)	Microsoft ACPI-Compliant System
 (ISA) 0x000001C6 (454)	Microsoft ACPI-Compliant System

 (ISA) 0x000001C7 (455)	Microsoft ACPI-Compliant System
 (ISA) 0x000001C8 (456)	Microsoft ACPI-Compliant System
 (ISA) 0x000001C9 (457)	Microsoft ACPI-Compliant System
 (ISA) 0x000001CA (458)	Microsoft ACPI-Compliant System
 (ISA) 0x000001CB (459)	Microsoft ACPI-Compliant System
 (ISA) 0x000001CC (460)	Microsoft ACPI-Compliant System
 (ISA) 0x000001CD (461)	Microsoft ACPI-Compliant System
 (ISA) 0x000001CE (462)	Microsoft ACPI-Compliant System
 (ISA) 0x000001CF (463)	Microsoft ACPI-Compliant System
 (ISA) 0x000001D0 (464)	Microsoft ACPI-Compliant System
 (ISA) 0x000001D1 (465)	Microsoft ACPI-Compliant System
 (ISA) 0x000001D2 (466)	Microsoft ACPI-Compliant System
 (ISA) 0x000001D3 (467)	Microsoft ACPI-Compliant System
 (ISA) 0x000001D4 (468)	Microsoft ACPI-Compliant System
 (ISA) 0x000001D5 (469)	Microsoft ACPI-Compliant System
 (ISA) 0x000001D6 (470)	Microsoft ACPI-Compliant System
 (ISA) 0x000001D7 (471)	Microsoft ACPI-Compliant System
 (ISA) 0x000001D8 (472)	Microsoft ACPI-Compliant System
 (ISA) 0x000001D9 (473)	Microsoft ACPI-Compliant System
 (ISA) 0x000001DA (474)	Microsoft ACPI-Compliant System
 (ISA) 0x000001DB (475)	Microsoft ACPI-Compliant System
 (ISA) 0x000001DC (476)	Microsoft ACPI-Compliant System
 (ISA) 0x000001DD (477)	Microsoft ACPI-Compliant System
 (ISA) 0x000001DE (478)	Microsoft ACPI-Compliant System
 (ISA) 0x000001DF (479)	Microsoft ACPI-Compliant System
 (ISA) 0x000001E0 (480)	Microsoft ACPI-Compliant System
 (ISA) 0x000001E1 (481)	Microsoft ACPI-Compliant System
 (ISA) 0x000001E2 (482)	Microsoft ACPI-Compliant System
 (ISA) 0x000001E3 (483)	Microsoft ACPI-Compliant System
 (ISA) 0x000001E4 (484)	Microsoft ACPI-Compliant System
 (ISA) 0x000001E5 (485)	Microsoft ACPI-Compliant System
 (ISA) 0x000001E6 (486)	Microsoft ACPI-Compliant System
 (ISA) 0x000001E7 (487)	Microsoft ACPI-Compliant System
 (ISA) 0x000001E8 (488)	Microsoft ACPI-Compliant System
 (ISA) 0x000001E9 (489)	Microsoft ACPI-Compliant System
 (ISA) 0x000001EA (490)	Microsoft ACPI-Compliant System
 (ISA) 0x000001EB (491)	Microsoft ACPI-Compliant System
 (ISA) 0x000001EC (492)	Microsoft ACPI-Compliant System
 (ISA) 0x000001ED (493)	Microsoft ACPI-Compliant System
 (ISA) 0x000001EE (494)	Microsoft ACPI-Compliant System
 (ISA) 0x000001EF (495)	Microsoft ACPI-Compliant System
 (ISA) 0x000001F0 (496)	Microsoft ACPI-Compliant System
 (ISA) 0x000001F1 (497)	Microsoft ACPI-Compliant System
 (ISA) 0x000001F2 (498)	Microsoft ACPI-Compliant System
 (ISA) 0x000001F3 (499)	Microsoft ACPI-Compliant System
 (ISA) 0x000001F4 (500)	Microsoft ACPI-Compliant System
 (ISA) 0x000001F5 (501)	Microsoft ACPI-Compliant System
 (ISA) 0x000001F6 (502)	Microsoft ACPI-Compliant System
 (ISA) 0x000001F7 (503)	Microsoft ACPI-Compliant System
 (ISA) 0x000001F8 (504)	Microsoft ACPI-Compliant System
 (ISA) 0x000001F9 (505)	Microsoft ACPI-Compliant System

	(ISA) 0x000001FA (506)	Microsoft ACPI-Compliant System
	(ISA) 0x000001FB (507)	Microsoft ACPI-Compliant System
	(ISA) 0x000001FC (508)	Microsoft ACPI-Compliant System
	(ISA) 0x000001FD (509)	Microsoft ACPI-Compliant System
	(ISA) 0x000001FE (510)	Microsoft ACPI-Compliant System
	(ISA) 0x000001FF (511)	Microsoft ACPI-Compliant System
	(PCI) 0x00000010 (16)	High Definition Audio Controller
	(PCI) 0x00000013 (19)	Intel(R) Active Management Technology - SOL (COM3)
	(PCI) 0xFFFFFFF3 (-13)	Intel(R) Management Engine Interface #1
	(PCI) 0xFFFFFFF4 (-12)	Intel(R) Ethernet Controller (3) I225-LM
	(PCI) 0xFFFFFFF5 (-11)	Intel(R) Ethernet Controller (3) I225-LM
	(PCI) 0xFFFFFFF6 (-10)	Intel(R) Ethernet Controller (3) I225-LM
	(PCI) 0xFFFFFFF7 (-9)	Intel(R) Ethernet Controller (3) I225-LM
	(PCI) 0xFFFFFFF8 (-8)	Intel(R) Ethernet Controller (3) I225-LM
	(PCI) 0xFFFFFFF9 (-7)	Intel(R) Ethernet Controller (3) I225-LM
	(PCI) 0xFFFFFFFA (-6)	Intel(R) Ethernet Controller (3) I225-LM
	(PCI) 0xFFFFFFFB (-5)	Intel(R) UHD Graphics
	(PCI) 0xFFFFFFFC (-4)	Intel(R) USB 3.20 eXtensible Host Controller - 1.20 (Microsoft)
	(PCI) 0xFFFFFFFD (-3)	Standard SATA AHCI Controller
	(PCI) 0xFFFFFFF0 (-2)	Intel(R) PCI Express Root Port #9 - 43B0