

FWS-7520

Network Appliance

User's Manual 1st Ed

Copyright Notice

This document is copyrighted, 2019. All rights are reserved. The original manufacturer reserves the right to make improvements to the products described in this manual at any time without notice.

No part of this manual may be reproduced, copied, translated, or transmitted in any form or by any means without the prior written permission of the original manufacturer. Information provided in this manual is intended to be accurate and reliable. However, the original manufacturer assumes no responsibility for its use, or for any infringements upon the rights of third parties that may result from its use.

The material in this document is for product information only and is subject to change without notice. While reasonable efforts have been made in the preparation of this document to assure its accuracy, AAEMON assumes no liabilities resulting from errors or omissions in this document, or from the use of the information contained herein.

AAEMON reserves the right to make changes in the product design without notice to its users.

Acknowledgement

All other products' name or trademarks are properties of their respective owners.

- Microsoft Windows is a registered trademark of Microsoft Corp.
- Intel, Pentium, Celeron, and Xeon are registered trademarks of Intel Corporation
- Core, Atom is a trademark of Intel Corporation
- ITE is a trademark of Integrated Technology Express, Inc.
- IBM, PC/AT, PS/2, and VGA are trademarks of International Business Machines Corporation.

All other product names or trademarks are properties of their respective owners.

Packing List

Before setting up your product, please make sure the following items have been shipped:

Item	Quantity
● FWS-7520	1
● EAR bracket kit	1
● Console cable	1
● Product DVD	1

If any of these items are missing or damaged, please contact your distributor or sales representative immediately.

About this Document

This User's Manual contains all the essential information, such as detailed descriptions and explanations on the product's hardware and software features (if any), its specifications, dimensions, jumper/connector settings/definitions, and driver installation instructions (if any), to facilitate users in setting up their product.

Users may refer to the product page on AAEON.com for the latest version of this document.

Safety Precautions

Please read the following safety instructions carefully. It is advised that you keep this manual for future references

1. All cautions and warnings on the device should be noted.
2. All cables and adapters supplied by AAEON are certified and in accordance with the material safety laws and regulations of the country of sale. Do not use any cables or adapters not supplied by AAEON to prevent system malfunction or fires.
3. Make sure the power source matches the power rating of the device.
4. Position the power cord so that people cannot step on it. Do not place anything over the power cord.
5. Always completely disconnect the power before working on the system's hardware.
6. No connections should be made when the system is powered as a sudden rush of power may damage sensitive electronic components.
7. If the device is not to be used for a long time, disconnect it from the power supply to avoid damage by transient over-voltage.
8. Always disconnect this device from any AC supply before cleaning.
9. While cleaning, use a damp cloth instead of liquid or spray detergents.
10. Make sure the device is installed near a power outlet and is easily accessible.
11. Keep this device away from humidity.
12. Place the device on a solid surface during installation to prevent falls
13. Do not cover the openings on the device to ensure optimal heat dissipation.
14. Watch out for high temperatures when the system is running.
15. Do not touch the heat sink or heat spreader when the system is running
16. Never pour any liquid into the openings. This could cause fire or electric shock.

17. As most electronic components are sensitive to static electrical charge, be sure to ground yourself to prevent static charge when installing the internal components. Use a grounding wrist strap and contain all electronic components in any static-shielded containers.
18. If any of the following situations arises, please contact our service personnel:
 - i. Damaged power cord or plug
 - ii. Liquid intrusion to the device
 - iii. Exposure to moisture
 - iv. Device is not working as expected or in a manner as described in this manual
 - v. The device is dropped or damaged
 - vi. Any obvious signs of damage displayed on the device
19. **DO NOT LEAVE THIS DEVICE IN AN UNCONTROLLED ENVIRONMENT WITH TEMPERATURES BEYOND THE DEVICE'S PERMITTED STORAGE TEMPERATURES (SEE CHAPTER 1) TO PREVENT DAMAGE.**

Warning!



This device complies with Part 15 FCC Rules. Operation is subject to the following two conditions: (1) this device may not cause harmful interference, and (2) this device must accept any interference received including interference that may cause undesired operation.

Caution:

There is a danger of explosion if the battery is incorrectly replaced. Replace only with the same or equivalent type recommended by the manufacturer. Dispose of used batteries according to the manufacturer's instructions and your local government's recycling or disposal directives.

Attention:

Il y a un risque d'explosion si la batterie est remplacée de façon incorrecte. Ne la remplacer qu'avec le même modèle ou équivalent recommandé par le constructeur. Recycler les batteries usées en accord avec les instructions du fabricant et les directives gouvernementales de recyclage.

China RoHS Requirements (CN)

产品中有毒有害物质或元素名称及含量

AAEON Embedded Box PC/ Industrial System

部件名称	有毒有害物质或元素					
	铅 (Pb)	汞 (Hg)	镉 (Cd)	六价铬 (Cr(VI))	多溴联苯 (PBB)	多溴二苯醚 (PBDE)
印刷电路板 及其电子组件	○	○	○	○	○	○
外部信号 连接器及线材	○	○	○	○	○	○
外壳	○	○	○	○	○	○
中央处理器 与内存	○	○	○	○	○	○
硬盘	○	○	○	○	○	○
电源	○	○	○	○	○	○
<p>O: 表示该有毒有害物质在该部件所有均质材料中的含量均在 SJ/T 11363-2006 标准规定的限量要求以下。</p> <p>X: 表示该有毒有害物质至少在该部件的某一均质材料中的含量超出 SJ/T 11363-2006 标准规定的限量要求。</p> <p>备注:</p> <p>一、此产品所标示之环保使用期限，系指在一般正常使用状况下。</p> <p>二、上述部件物质中央处理器、内存、硬盘、光驱、触控模块为选购品。</p>						

China RoHS Requirement (EN)

Poisonous or Hazardous Substances or Elements in Products
 AAEON Embedded Box PC/ Industrial System

Component	Poisonous or Hazardous Substances or Elements					
	Lead (Pb)	Mercury (Hg)	Cadmium (Cd)	Hexavalent Chromium (Cr(VI))	Polybrominated Biphenyls (PBB)	Polybrominated Diphenyl Ethers (PBDE)
PCB & Other Components	○	○	○	○	○	○
Wires & Connectors for External Connections	○	○	○	○	○	○
Chassis	○	○	○	○	○	○
CPU & RAM	○	○	○	○	○	○
Hard Disk	○	○	○	○	○	○
PSU	○	○	○	○	○	○

O: The quantity of poisonous or hazardous substances or elements found in each of the component's parts is below the SJ/T 11363-2006-stipulated requirement.

X: The quantity of poisonous or hazardous substances or elements found in at least one of the component's parts is beyond the SJ/T 11363-2006-stipulated requirement.

Note: The Environment Friendly Use Period as labeled on this product is applicable under normal usage only

Table of Contents

Chapter 1 - Product Specifications	1
1.1 Specifications.....	2
Chapter 2 – Hardware Information	5
2.1 Dimensions	6
2.2 Jumpers and Connectors	11
2.3 List of Jumpers	14
2.3.1 CFD Voltage 3.3V/5V Selection (JP1).....	15
2.3.2 Auto PWRBTN Selection (JP2).....	15
2.3.3 IPMI PWRBTN Setting Selection (JP3).....	15
2.3.4 CMOS Setting Selection (CMOS1).....	15
2.4 List of Connectors.....	16
2.4.1 Power Switch Header (CN1)	17
2.4.2 Digital I/O (DIO1)	17
2.4.3 Front Panel Connector 1 (FP1).....	18
2.4.4 Front Panel Connector 2 (FP2).....	18
2.4.5 USB3.0 Box Header (USB1)	19
2.4.6 USB3.0 Box Header (USB2)	19
2.5 List of Connectors (PER-T362).....	21
2.6 Installing 2.5" Hard Disk Drives (2 Pieces).....	22
2.7 Installing 2.5" Hard Disk Drives (4 Pieces).....	27
2.8 Installing 3.5" Hard Disk (1 Piece).....	34
2.9 Installing Expansion Card	37
2.10 Installing Network Interface Module.....	39
Chapter 3 - AMI BIOS Setup	41
3.1 System Test and Initialization.....	42
3.2 AMI BIOS Setup.....	43

3.3	Setup Submenu: Main.....	44
3.4	Setup Submenu: Advanced.....	45
3.4.1	Advanced: Trusted Computing.....	46
3.4.2	Advanced: Hardware monitor.....	47
3.4.2.1	Hardware monitor: Smart Fan Mode Configuration (Manual Mode)	48
3.4.2.2	Hardware monitor: Smart Fan Mode Configuration (Automatic Mode).....	49
3.4.3	Advanced: JMB36X ATA controller Configuration.....	50
3.4.4	Advanced: Serial Port Console Redirection	51
3.4.4.1	Serial Port Console Redirection: COM0 Console Redirection Settings.....	52
3.4.4.2	Serial Port Console Redirection: Console Redirection Settings.....	54
3.4.5	Advanced: SIO Configuration.....	55
3.4.5.1	SIO Configuration: Serial Port1 Configuration.....	56
3.4.5.2	SIO Configuration: Serial Port2 Configuration	57
3.4.5.3	SIO Configuration: Parallel Port Configuration.....	58
3.4.6	Advanced: USB Configuration.....	59
3.4.7	Advanced: Digital IO Port Configuration.....	60
3.4.8	Advanced: Power Management.....	61
3.4.9	Advanced: LAN Bypass Configuration	62
3.5	Setup submenu: IntelRCSetup.....	63
3.5.1	IntelRCSetup: Processor Configuration	64
3.5.2	IntelRCSetup: Memory Configuration	65
3.5.3	IntelRCSetup: PCH Configuration.....	66
3.5.3.1	PCH Configuration: PCH Devices	67
3.5.3.2	PCH Configuration: PCI Express Configuration.....	68

3.5.3.3	PCH Configuration: SATA Configuration (IDE).....	69
3.5.3.4	PCH Configuration: SATA Configuration (AHCI).....	70
3.5.3.5	PCH Configuration: SATA Configuration (RAID).....	71
3.6	Setup submenu: Server Mgmt (Option).....	72
3.6.1	Server Mgmt: System Event Log.....	74
3.6.2	Server Mgmt: BMC self test log.....	75
3.6.2	Server Mgmt: View FRU information.....	76
3.6.3	Server Mgmt: BMC network configuration.....	77
3.6.3.1	BMC network configuration: View System Event Log.....	78
3.6.3.2	BMC network configuration: BMC User Settings.....	79
3.7	Setup submenu: Security.....	80
3.8	Setup submenu: Boot.....	81
3.9	Setup submenu: Save & Exit.....	82
Chapter 4	– Drivers Installation.....	83
4.1	Drivers Installation.....	84
Appendix A	- Watchdog Timer Programming.....	85
A.1	Watchdog Timer Initial Program.....	86
Appendix B	- I/O Information.....	92
B.1	I/O Address Map.....	93
B.2	Memory Address Map.....	95
B.3	IRQ Mapping Chart.....	98
Appendix C	- Standard LAN Bypass Platform Setting.....	115
C.1	Status LED.....	116
C.2	LAN Bypass.....	119
C.3	Software Reset Button (General Propose Input).....	122

Chapter 1

Product Specifications

1.1 Specifications

System

- **Processor** Intel® FCBGA Xeon D-1548/D-1518 (Optional)
SOC
- **System Memory** 4 x 288-pin DDR4 1600/1867/2133MHz RDIMM
up to 128GB
- **Chipset** -
- **Ethernet** Intel® Ethernet Controller I210-AT
Up to 24 x 10/100/1000Base-TX Ethernet port
(Optional w/ NIM),
- **BIOS** AMI BIOS
- **Serial ATA** SATA III ports on board x 5
- **SSD** -
- **Expansion Interface** 1 x PCIe [x4] slot (with [x8] connector)
(optional)
1 x Mini-PCIe slot
- **Watchdog Timer** System reset: 1~255 steps by software
programming
- **RTC** Internal RTC
- **Storage** 2.5" SATA HDD bay x 2
CompactFlash™ socket x 1
- **Front Panel I/O** Power LED x 1
Status LED x 1
HDD Active LED x 1
USB 3.0 Ports x 2

	NIM slots x 3
	RJ45 IPMI x 1
	10GbE SFP+ x 2
	RJ45 Console x 1
	LCM display and 4 keypad x 1
	Software Programmable Switch x 1
● Rear Panel I/O	AC power input x 1
	Power Switch x 1
	Expansion Slot x 1 (optional 1 x PCIe [x4], with PCIe [x8] connector)
	VGA port (optional)
● Color	Black
● Power Supply	250W x1 AC Power Input / 220W Redundant
● Dimension (W x D x H)	430 x 44 x 475 mm (16.9 x 1.73 x 18.7")

Graphics

● Chipset	SoC integrated
● Graphic Engine	Gen 7 with 4 Eus
● Resolution	2560 x 1600
● Output Interface	Optional w/ IPMI or add-on Mini PCI-E VGA card

I/O

● Serial Port	RJ-45 console x 1
● Keyboard and Mouse	2x4 Pin Header (2.54mm) x1
● USB	USB 3.0 Type A on I/O side x 2

Environmental

- **Operating Temperature** 0 ~40°C (32 ~ 104°F)
- **Storage Temperature** -20 ~60°C (-4 ~140°F)
- **Operating Humidity** 10%~80% relative humidity, non-condensing
- **Storage Humidity** 10%~80% @ 40°C, non-condensing
- **Anti-Vibration** 0.5 Grms/5~500Hz/ operation
1.5 Grms/5~500Hz/ non-operation
- **Anti-Shock** 10G peak acceleration (11m sec. duration),
operation
20G peak acceleration (11m sec. duration), non
operation

Chapter 2

Hardware Information

2.1 Dimensions

System

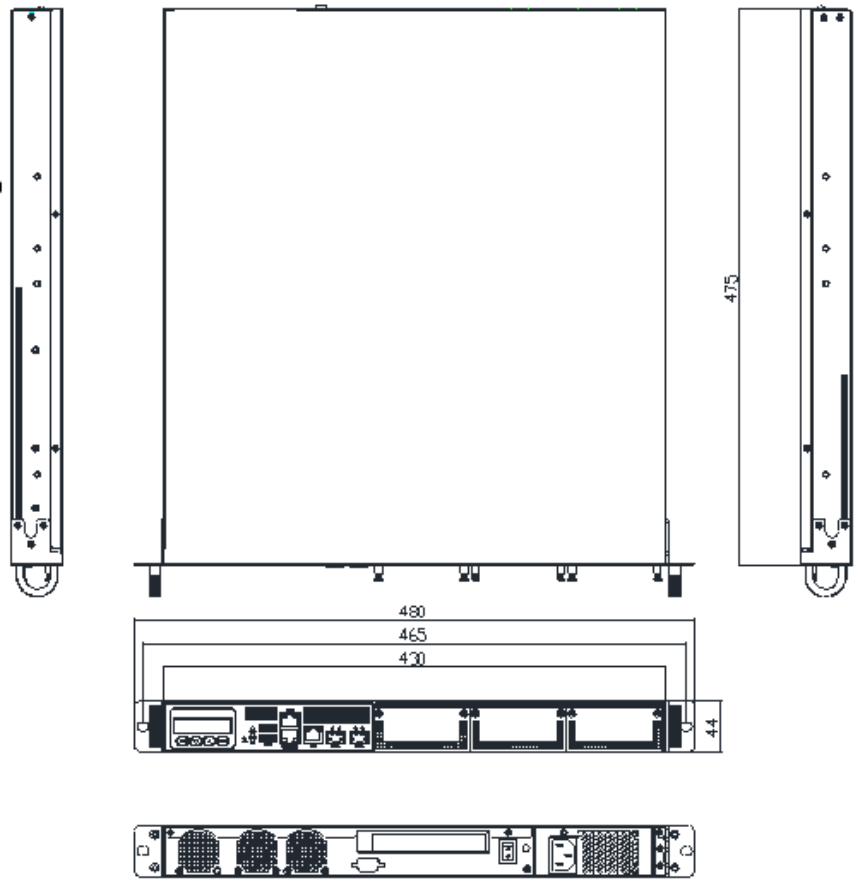

Board

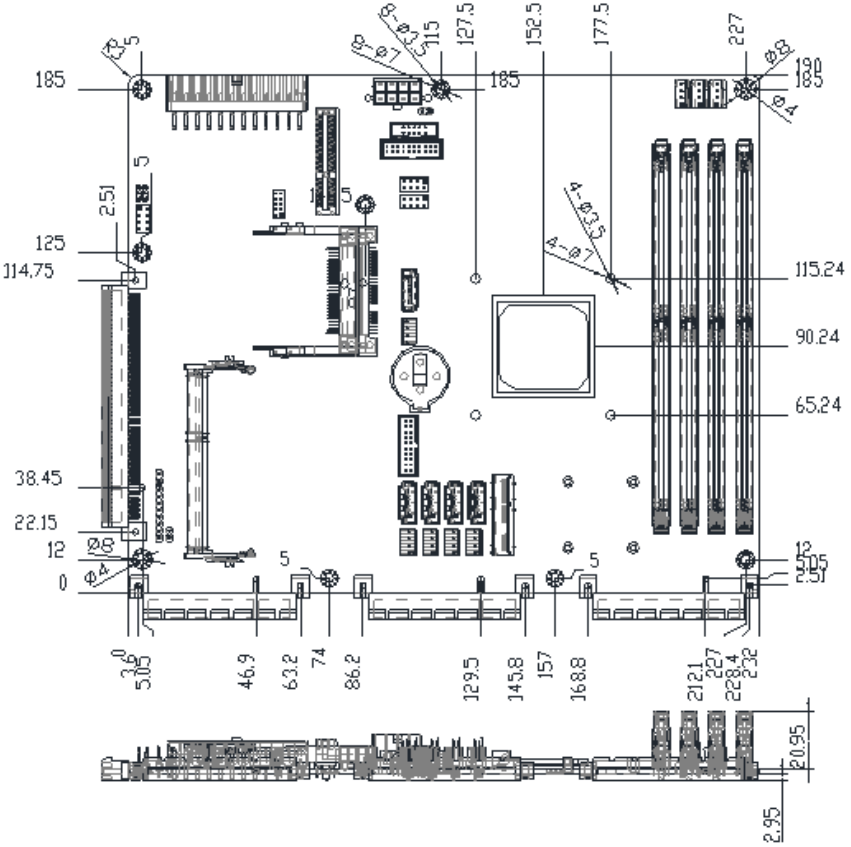

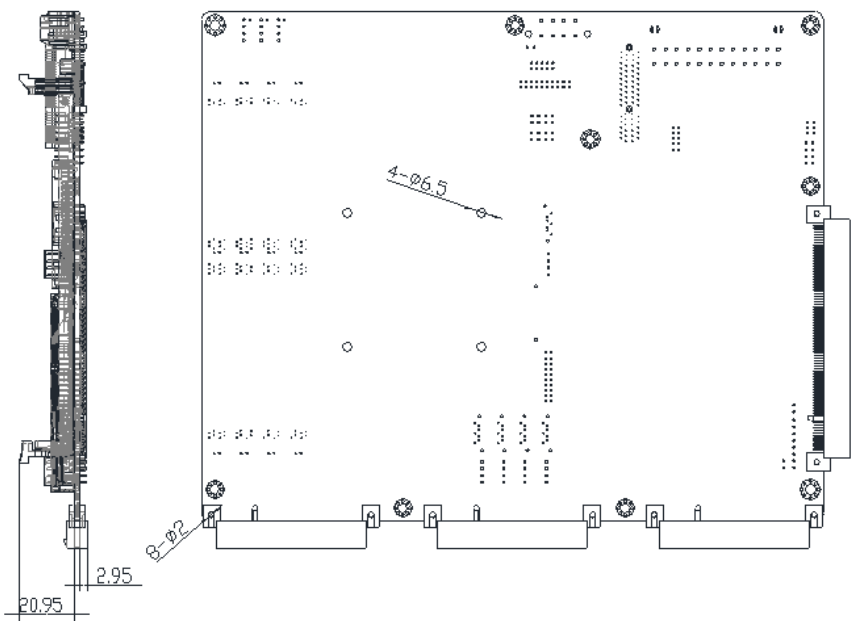

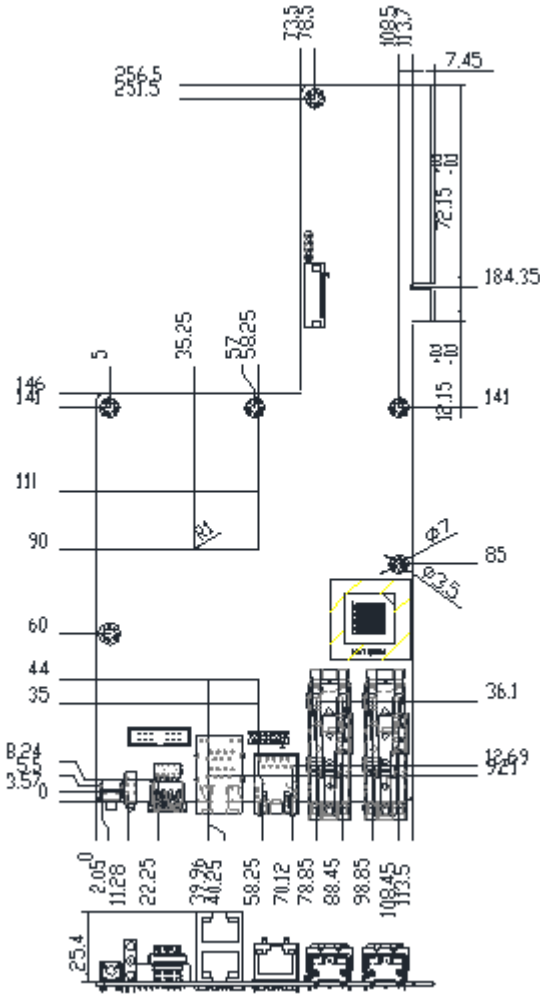

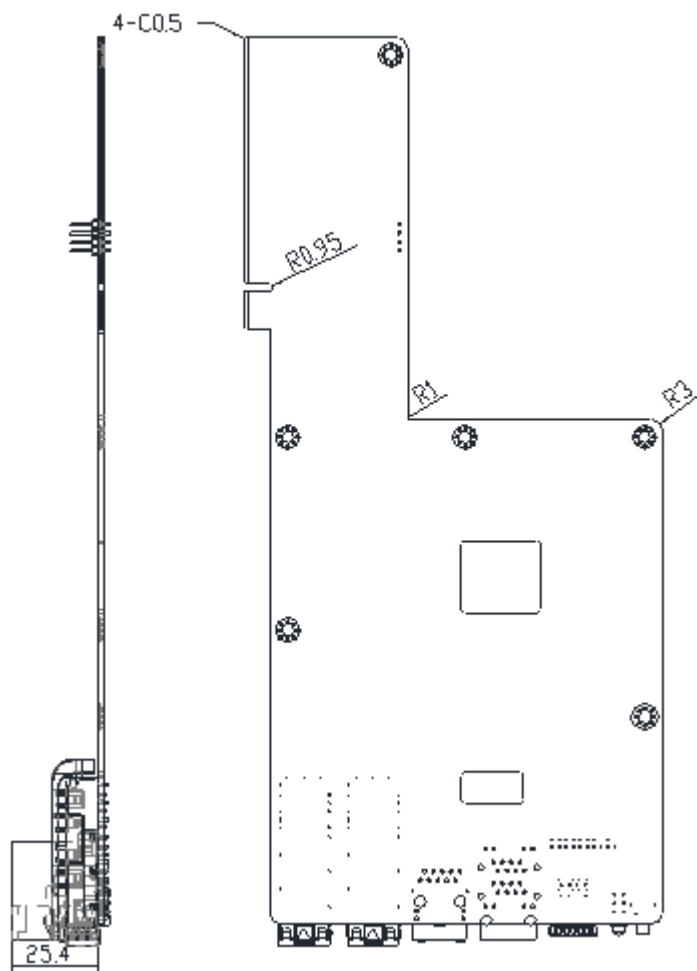

2.2 Jumpers and Connectors

Component Side

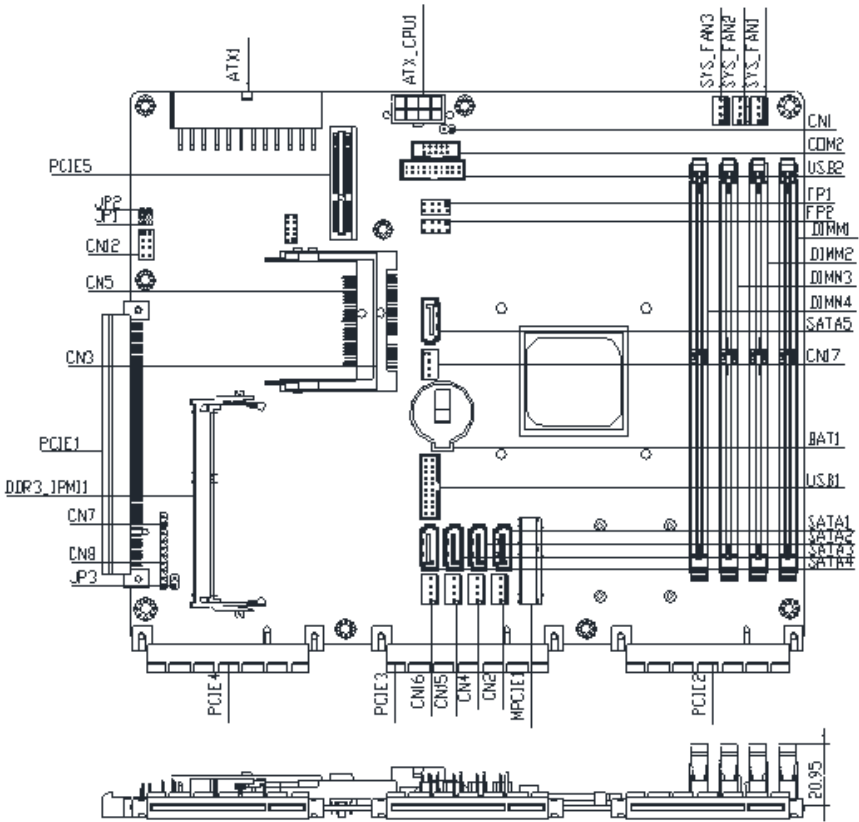

Solder Side

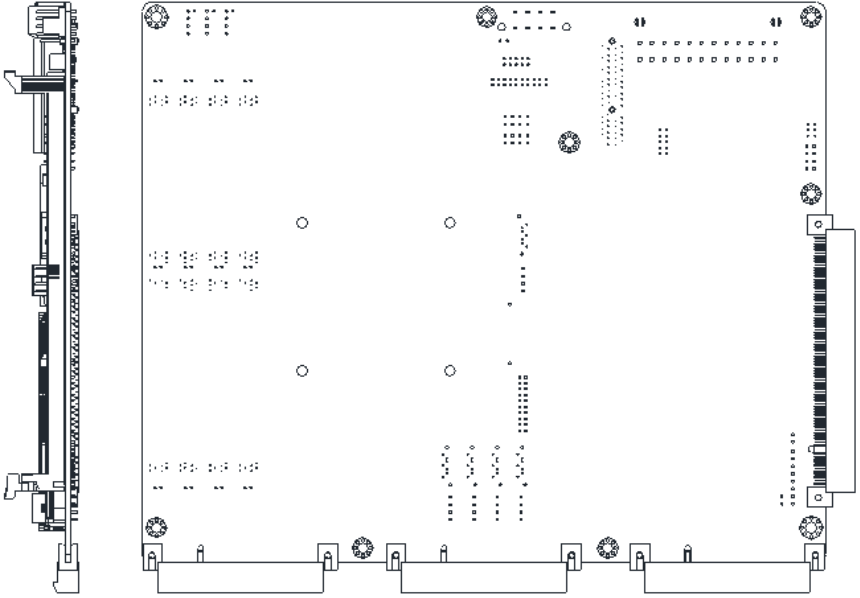

PER-T362

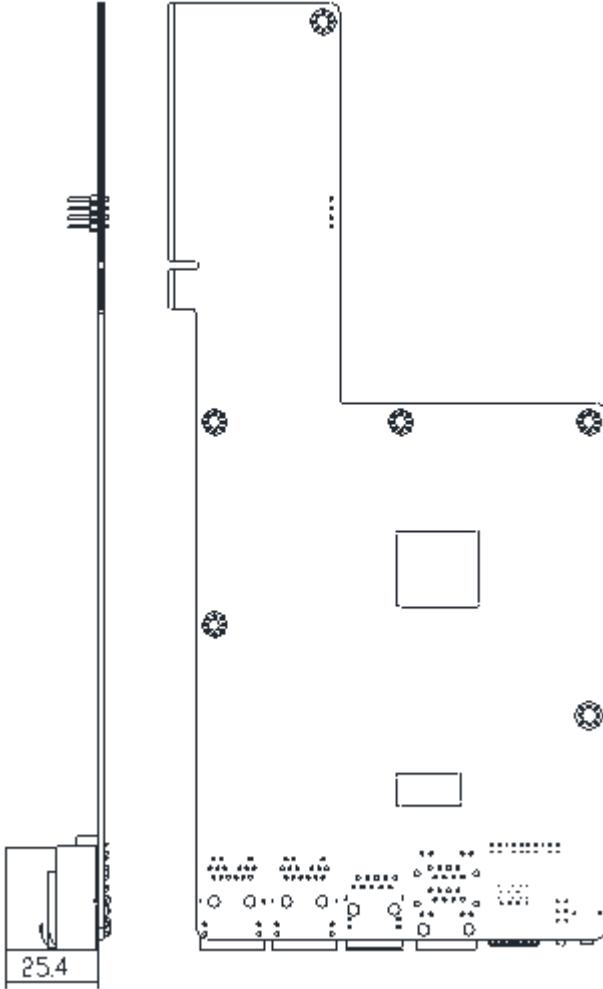

2.3 List of Jumpers

Please refer to the table below for all of the board's jumpers that you can configure for your application

Label	Function
JP1	CF POWER Selection
JP2	Auto PWRBTN Selection
JP3	IPMI PWRBTN Setting Selection
CMOS1	CMOS setting selection

2.3.1 CFD Voltage 3.3V/5V Selection (JP1)

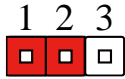

+5V (Default)

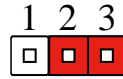

+3.3 V

2.3.2 Auto PWRBTN Selection (JP2)

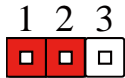

Don't use Auto PWRBTN (Default)

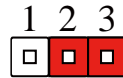

Use Auto PWRBTN

2.3.3 IPMI PWRBTN Setting Selection (JP3)



W/O IPMI Card (Default)



W/ IPMI Card

2.3.4 CMOS Setting Selection (CMOS1)

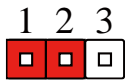

Normal (Default)

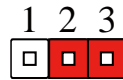

Clear CMOS

2.4 List of Connectors

Please refer to the table below for all of the board's connectors that you can configure for your application

Label	Function
DIMM1~4	DDR4 RDIMM socket
ATX1	24-pin ATX power supply input
ATX_CPU1	8P ATX power supply input
SYS_FAN1,3,5	4-pin smart fan
CN12	KB/MS
COM2	COM port
SATA1~5	SATA6G interface
CN2, 4, 15, 16, 17	SATA power
MPCIE1	Mini PCIe socket
CN3	CF card socket
CN1	Power switch
FP1	Front panel connector 1
FP2	Front panel connector 2
USB1	USB2.0/USB3.0 Port Box Header
USB2	Only USB3.0 Port Box Header
DIO1	Digital I/O

2.4.1 Power Switch Header (CN1)

Pin	Signal	Pin	Signal
1	Power Button	2	GND

2.4.2 Digital I/O (DIO1)

This connector offers 4-pair of digital I/O functions and address is 801H. The pin definitions are illustrated below:

Pin	Signal	Pin	Signal
1	Digital- IN/OUT (Port1 Bit 1)	2	Digital- IN/OUT (Port1 Bit 2)
3	Digital- IN/OUT (Port1 Bit 4)	4	Digital- IN/OUT (Port1 Bit 5)
5	Digital- IN/OUT (Port3 Bit 4)	6	Digital- IN/OUT (Port3 Bit 5)
7	Digital- IN/OUT (Port6 Bit 3)	8	Digital- IN/OUT (Port4 Bit 7)
9	+3.3V	10	GND

The pin definitions and registers mapping are illustrated below:

Address: 801H

4 in/ 4 out							
Pin 1	Pin 2	Pin 3	Pin 4	Pin 5	Pin 6	Pin 7	Pin 8
GPI 11	GPI 12	GPI 14	GPI 15	GPO 34	GPO 35	GPO 63	GPO 47

8 in							
Pin 1	Pin 2	Pin 3	Pin 4	Pin 5	Pin 6	Pin 7	Pin 8
GPI 11	GPI 12	GPI 14	GPI 15	GPO 34	GPO 35	GPO 63	GPO 47

8 out							
Pin 1	Pin 2	Pin 3	Pin 4	Pin 5	Pin 6	Pin 7	Pin 8
GPI 11	GPI 12	GPI 14	GPI 15	GPO 34	GPO 35	GPO 63	GPO 74

2.4.3 Front Panel Connector 1 (FP1)

Pin	Signal	Pin	Signal
1	Power On Button (+)	2	Reset Switch (+)
3	Power On Button (-)	4	Reset Switch (-)
5	HDD LED (+)	6	Power LED (+)
7	HDD LED (-)	8	Power LED (-)

2.4.4 Front Panel Connector 2 (FP2)

Pin	Signal	Pin	Signal
1	N/A	2	Keyboard Lock (+)
3	N/A	4	GND
5	N/A	6	I2C Bus SMB Clock
7	N/A	8	I2C Bus SMB Data

*Close Pin 5, 7 to enable internal buzzer

2.4.5 USB3.0 Box Header (USB1)

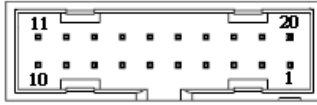

Pin	Signal	Pin	Signal
1	+5V_USB	11	USBP_1P
2	USB3_RX1_DN	12	USBP_1N
3	USB3_RX1_DP	13	GND
4	GND	14	USB3_TX2_DP
5	USB3_TX1_DN	15	USB3_TX2_DN
6	USB3_TX1_DP	16	GND
7	GND	17	USB3_RX2_DP
8	USBP_ON	18	USB3_RX2_DN
9	USBP_OP	19	+5V_USB
10	N.C.	20	N.C.

2.4.6 USB3.0 Box Header (USB2)

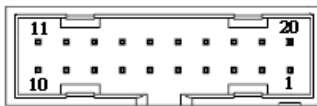

Pin	Signal	Pin	Signal
1	+5V_USB	11	N.C.
2	USB3_RX1_DN	12	N.C.
3	USB3_RX1_DP	13	GND
4	GND	14	USB3_TX2_DP
5	USB3_TX1_DN	15	USB3_TX2_DN

6	USB3_TX1_DP	16	GND
7	GND	17	USB3_RX2_DP
8	N.C.	18	USB3_RX2_DN
9	N.C.	19	+5V_USB
10	N.C.	20	N.C.

2.5 List of Connectors (PER-T362)

Please refer to the table below for all of the module's connectors that you can configure for your application



Label	Function
SW1	Reset Switch (By Control)
USB	USB 3.0 Connector
IPMI	IPMI Connector
CONSOLE	CONSOLE Connector
LAN	10/100/1000 Base Ethernet Connector
SFP+1	10G SFP+ Fiber Connector
SFP+2	10G SFP+ Fiber Connector

2.6 Installing 2.5" Hard Disk Drives (2 Pieces)

1. Remove the highlighted screws



2. From the front of the system, slide it upwards to remove



3. Remove the four highlighted screws to remove the HDD bracket

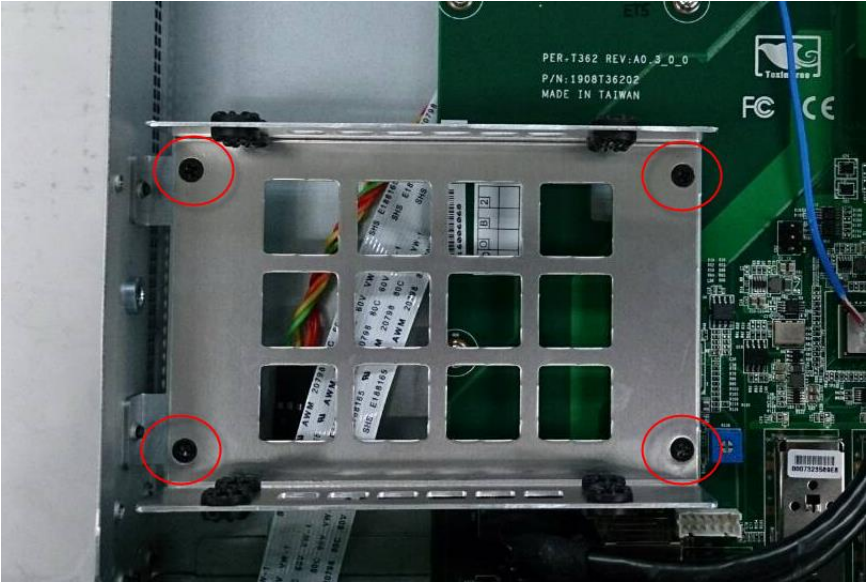

4. Place the HDDs into the bracket, tighten the screws to secure

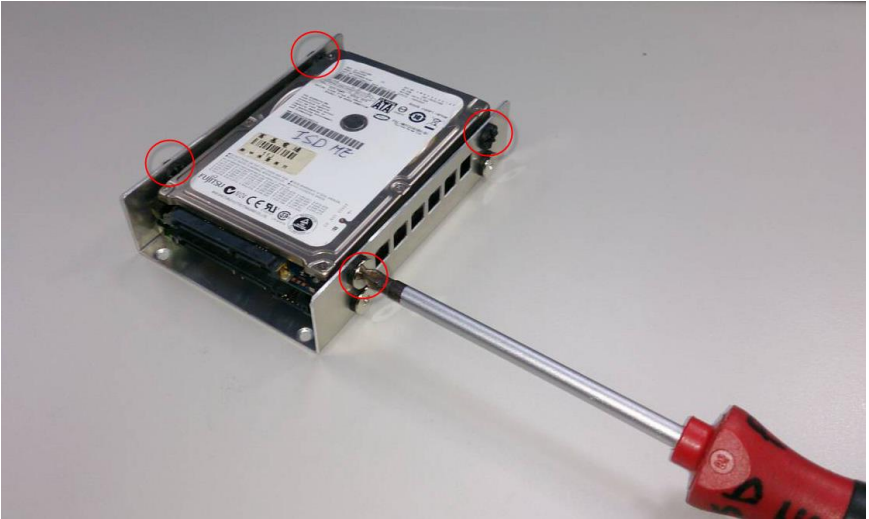

- 5. Place the assembled HDDs back into the system, secure with screws and reattach the SATA and power cables.



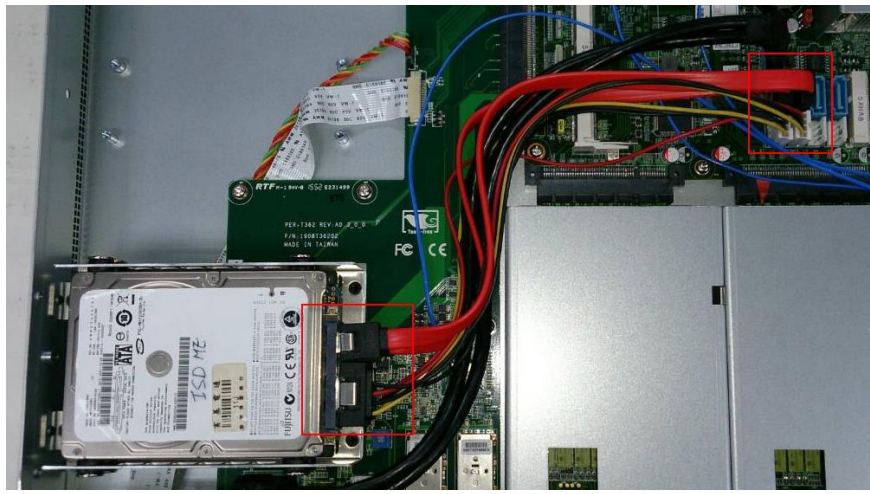
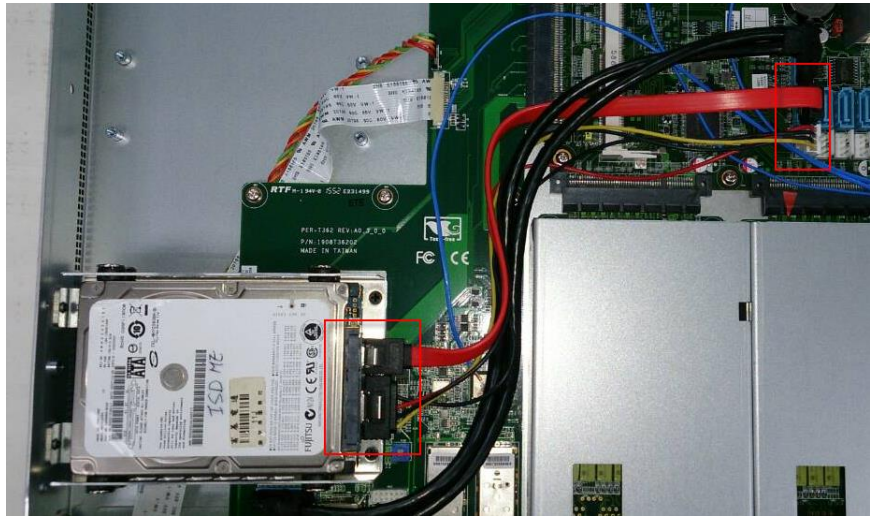

2.7 Installing 2.5" Hard Disk Drives (4 Pieces)

1. Remove the highlighted screws



2. From the front of the system, slide it upwards to remove



3. Remove the eight highlighted screws to remove the HDD brackets

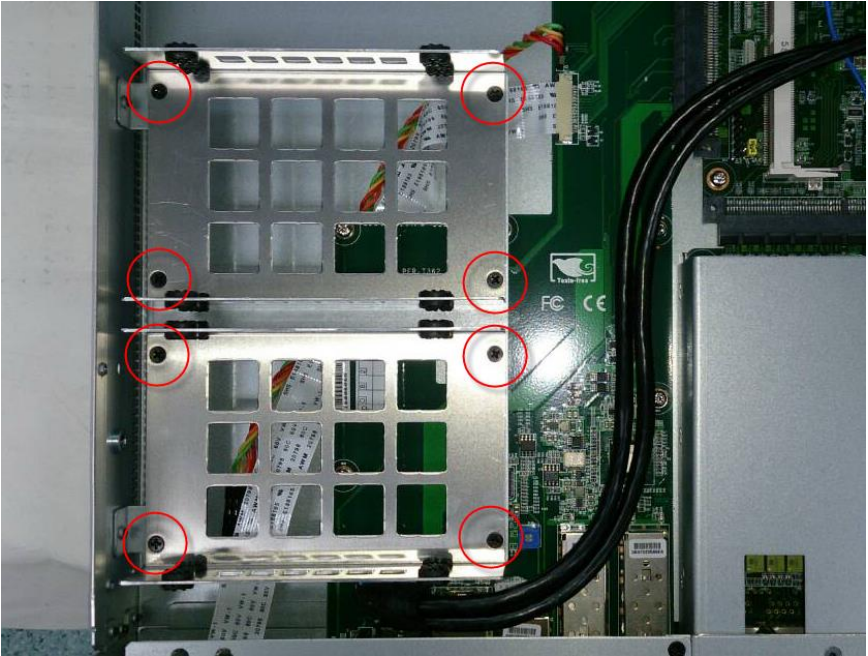

4. Place the HDDs into the bracket, tighten the screws to secure

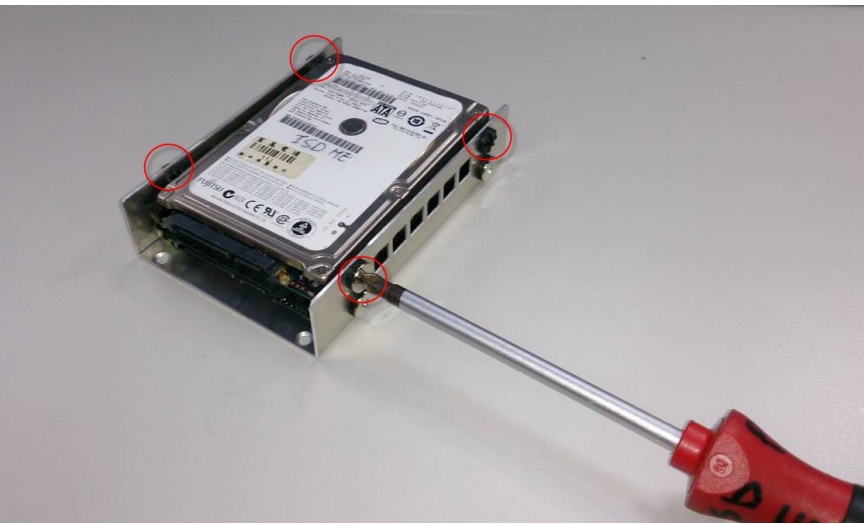

- 5. Place the assembled HDDs back into the system, secure with screws and reattach the SATA and power cables.





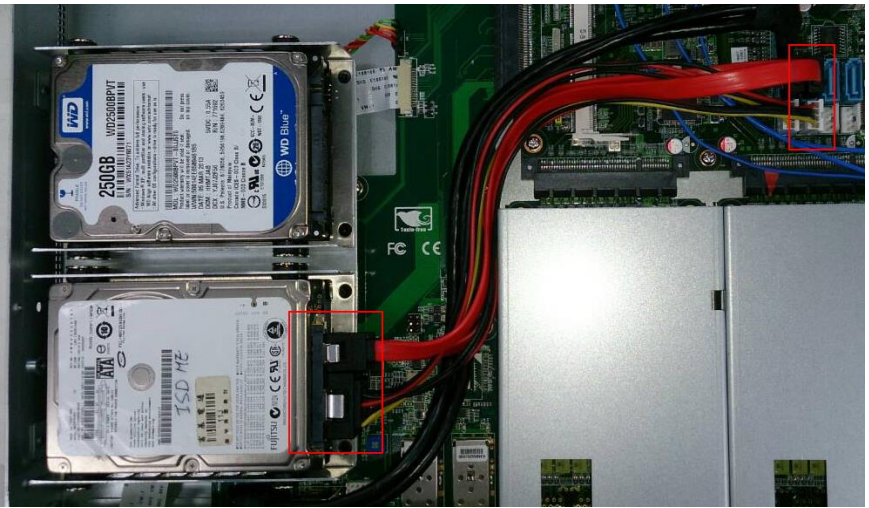

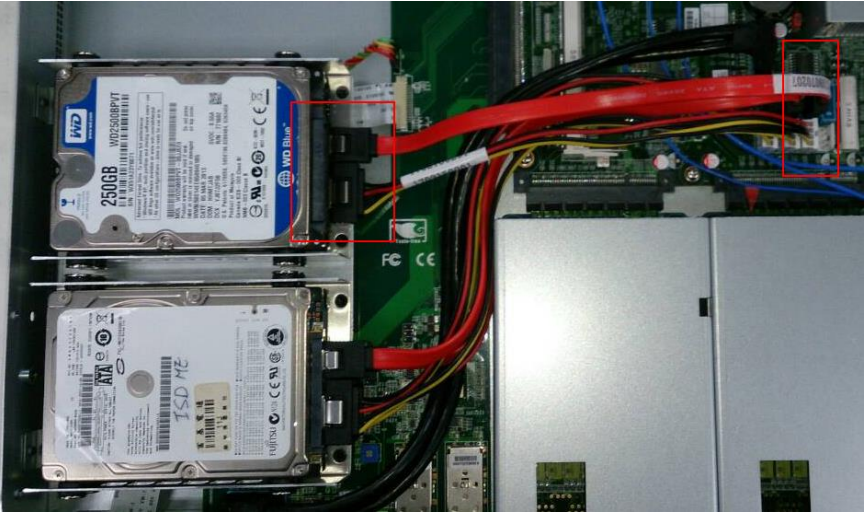

2.8 Installing 3.5" Hard Disk (1 Piece)

1. Remove the highlighted screws



2. From the front of the system, slide it upwards to remove



3. Remove the screws to remove the bracket

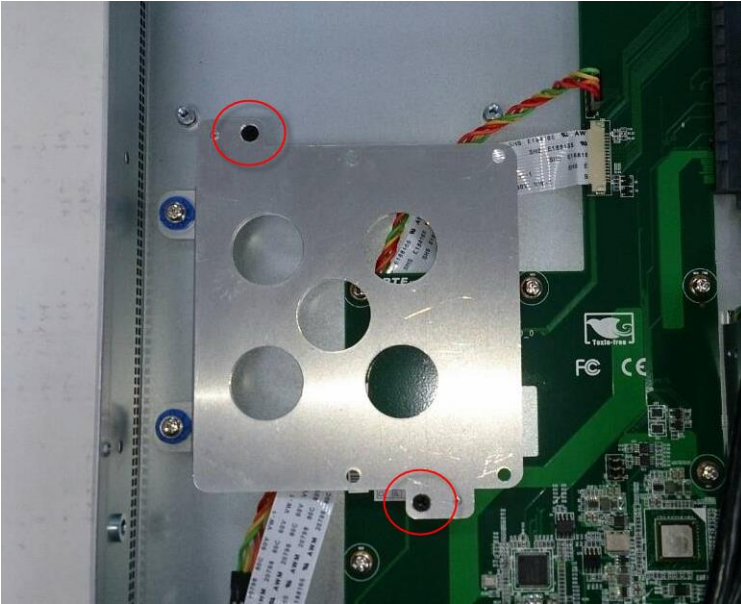

4. Place the 3.5" HDD on the bracket, secure with screws on the underside

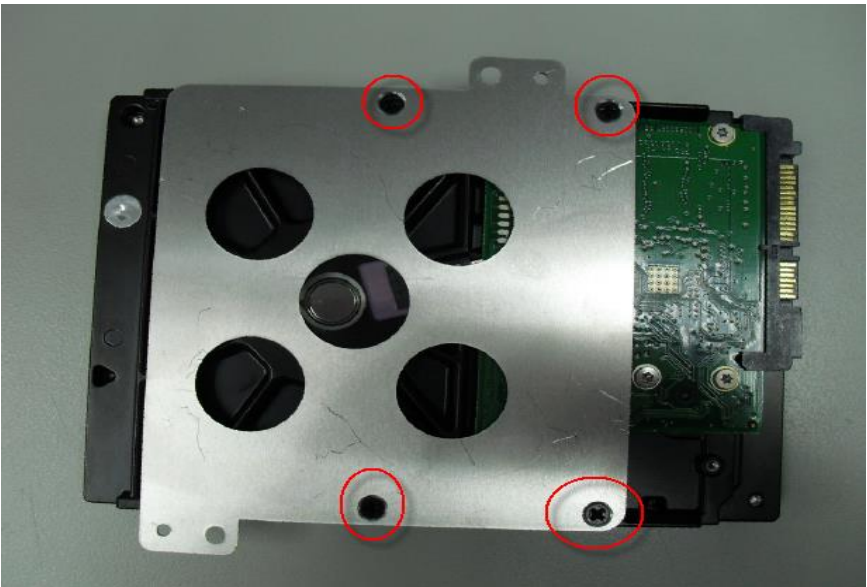

- 5. Put the assembled HDD on the HDD bay, secure with screws and reattach the SATA and power cables



2.9 Installing Expansion Card

1. Remove the highlighted screws



2. From the front of the system, slide it upwards to remove



3. Remove the screw to remove the cover bracket



4. Firmly insert the expansion card into the slot and secure the screw.

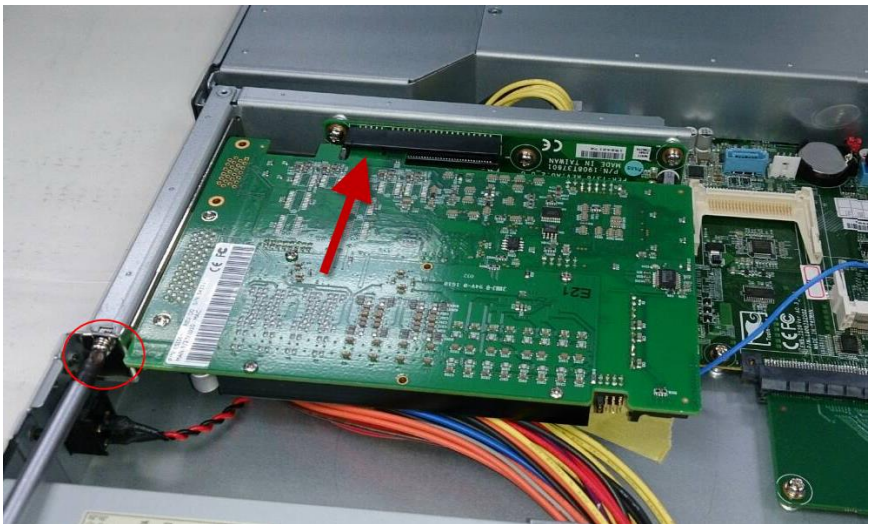

2.10 Installing Network Interface Module

1. Remove the highlighted screws to remove the NIM cover



2. Remove the highlighted screws to remove the NIM



3. Insert the NIM and secure with screws



4. Close the NIM cover and secure with screws



Chapter 3

AMI BIOS Setup

3.1 System Test and Initialization

The system uses certain routines to perform testing and initialization. If an error, fatal or non-fatal, is encountered, a few short beeps or an error message will be outputted. The board can usually continue the boot up sequence with non-fatal errors.

The system configuration verification routines check the current system configuration against the values stored in the CMOS memory. If they do not match, an error message will be outputted, in which case you will need to run the BIOS setup program to set the configuration information in memory.

There are three situations in which you will need to change the CMOS settings:

- You are starting your system for the first time
- You have changed your system's hardware
- The CMOS memory has lost power and the configuration information is erased

The system's CMOS memory uses a backup battery for data retention, which is to be replaced once emptied.

3.2 AMI BIOS Setup

The AMI BIOS ROM has a pre-installed Setup program that allows users to modify basic system configurations, which is stored in the battery-backed CMOS RAM and BIOS NVRAM so that the information is retained when the power is turned off.

To enter BIOS Setup, press or <F2> immediately while your computer is powering up.

The function for each interface can be found below.

Main – Date and time can be set here. Press <Tab> to switch between date elements

Advanced – Advanced setup parameters

IntelRCSetup – For hosting bridge parameters

Server Mgmt – Server Management parameters

Security – The setup administrator password can be set here

Boot – Enable/ Disable quiet Boot Option

Save & Exit – Save your changes and exit the program

3.3 Setup Submenu: Main

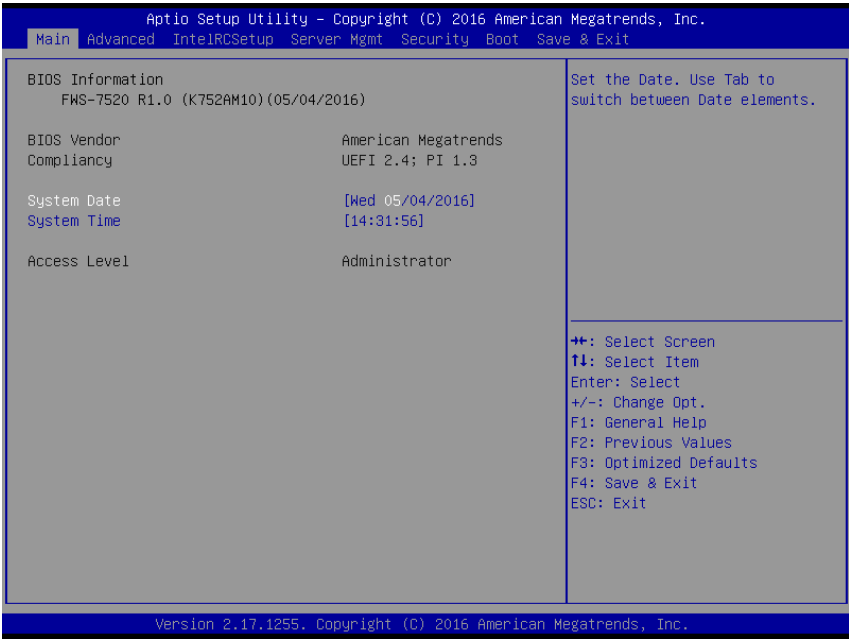

3.4 Setup Submenu: Advanced

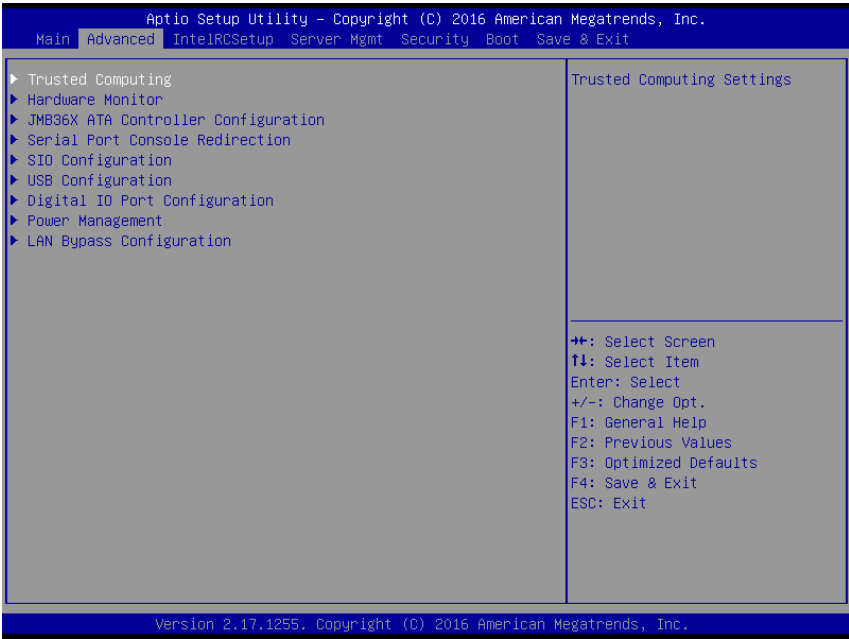

3.4.1 Advanced: Trusted Computing

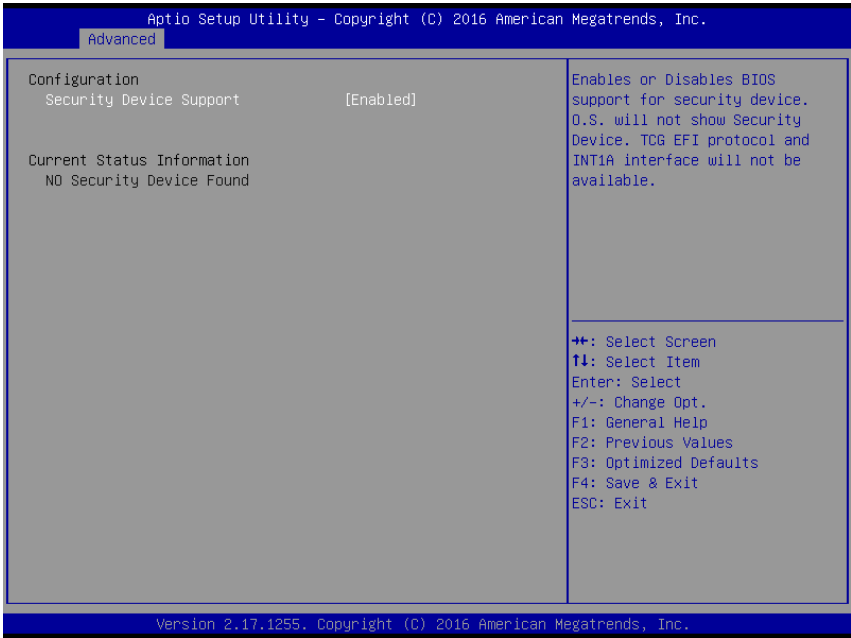

Options summary:

Security Device Support	Disable	Default
	Enable	
Enable or Disables BIOS support for security device. O.S. will not show Security Device. TCG EFI protocol and INT1A interface will not be available.		

3.4.2 Advanced: Hardware monitor

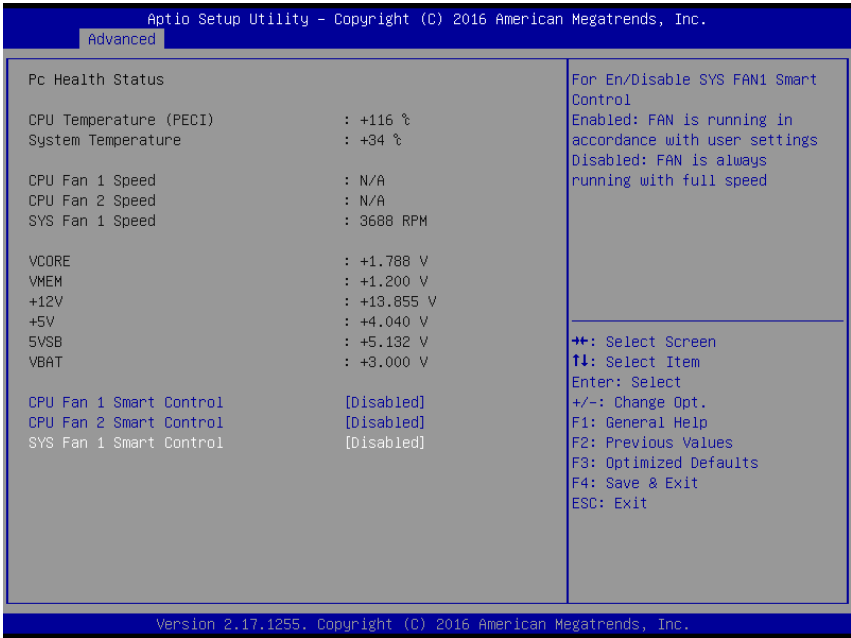

Options summary:

CPU Fan 1 Smart Control	Disabled	Default
	Enabled	
Allows BIOS to En/Disable CPU Fan 1 Smart Control		
CPU Fan 2 Smart Control	Disabled	Default
	Enabled	
Allows BIOS to En/Disable CPU Fan 2 Smart Control		
SYS Fan 1 Smart Control	Disabled	Default
	Enabled	
Allows BIOS to En/Disable System Fan 1 Smart Control		

3.4.2.1 Hardware monitor: Smart Fan Mode Configuration (Manual Mode)

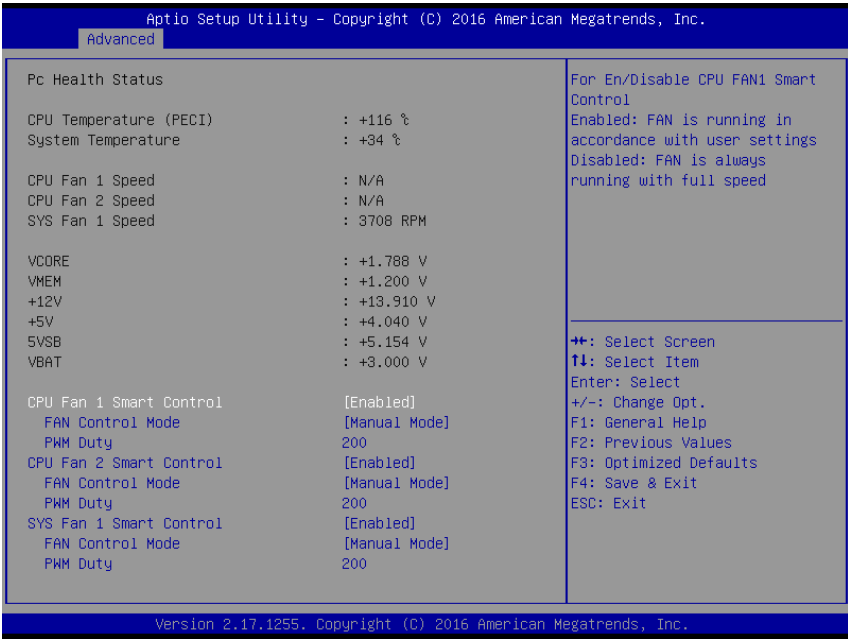

Options summary:

FAN Control Mode	Manual Mode	Default
	Automatic Mode	
Manual Mode: Depends on PWM Duty. Automatic Mode: FAN Speed is depends on CPU Temperature.		
PWM Duty	0 – 255	Default (200)
Manual Mode PWM Duty value Range:[0 - 255]		

3.4.2.2 Hardware monitor: Smart Fan Mode Configuration (Automatic Mode)

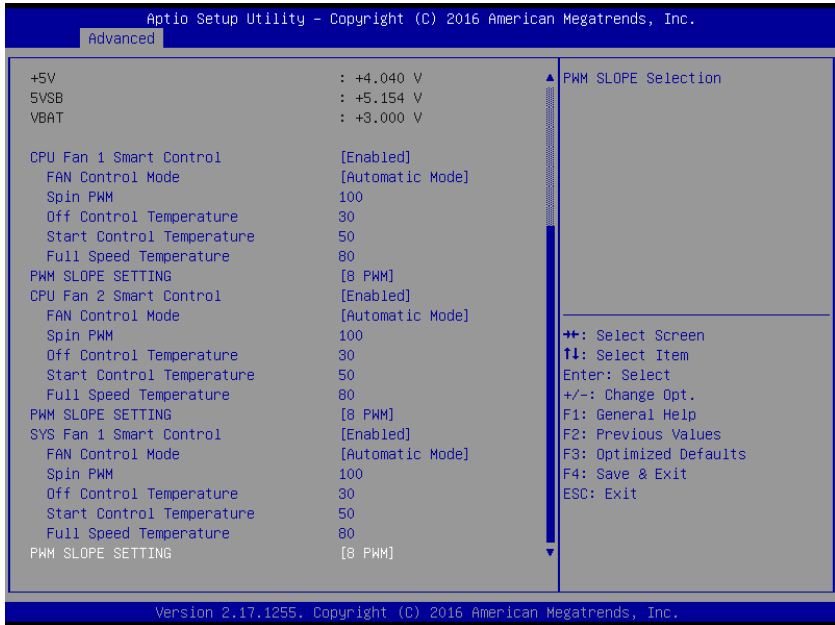

Options summary:

FAN Control Mode	Manual Mode	Default
	Automatic Mode	
Smart Fan Mode Select.		
Spin PWM	0 ~ 255	Default (100)
The PWM Duty of FAN Spin Range:[0 - 255]		
Off Control Temperature	0 ~ 127	Default (30)
Temperature Limit Value of Fan Off. Note: Some fans have the minimum speed even if the PWM value is 0		
Start Control Temperature	0 ~ 127	Default (50)
Temperature Limit Value of FAN Start Control		
Full Speed Temperature	0 ~ 127	Default (80)
Temperature Limit Value of FAN Full Speed		
PWM SLOPE SETTING	0 ~ 15	Default (8)
PWM SLOPE Selection		

3.4.3 Advanced: JMB36X ATA controller Configuration

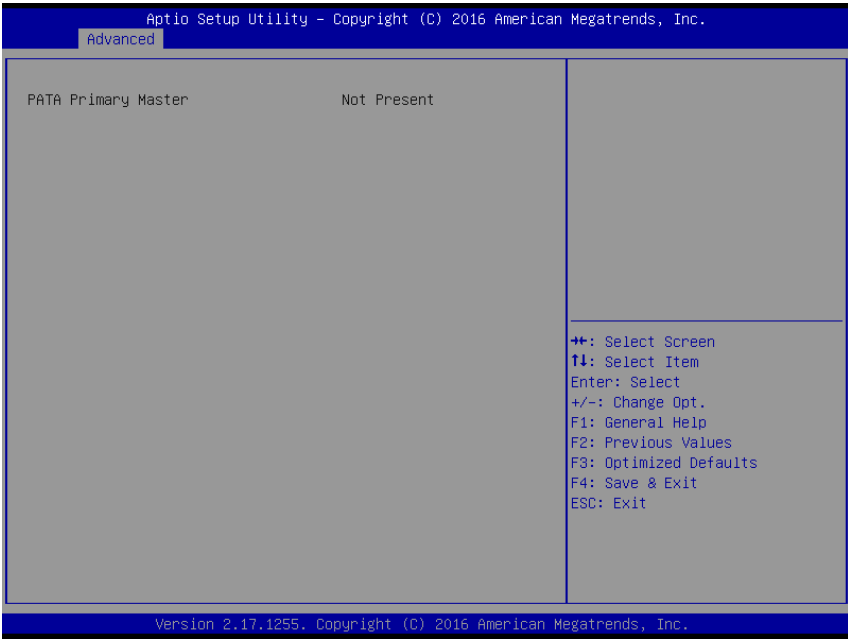

3.4.4 Advanced: Serial Port Console Redirection

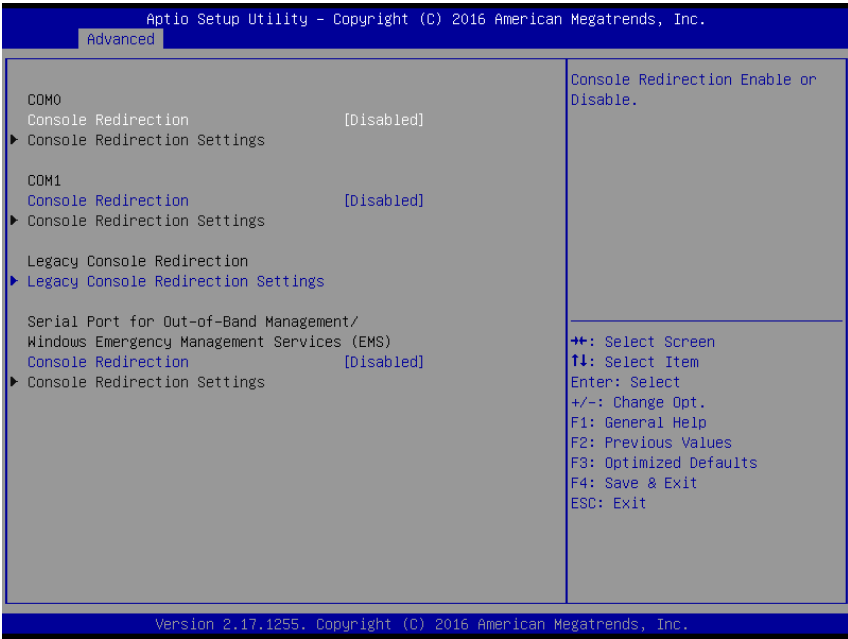

Options summary:

Console Redirection	Enabled	Default
	Disabled	
Console Redirection Enable or Disable.		
Legacy Console Redirection	Com0	Default
	Com1	
Select Legacy Console Redirection port		
Console Redirection(EMS)	Enabled	Default
	Disabled	
Microsoft Windows Emergency Management Services (EMS) allows for remote management of a Windows Server OS through a serial port.		

3.4.4.1 Serial Port Console Redirection: COM0 Console Redirection Settings

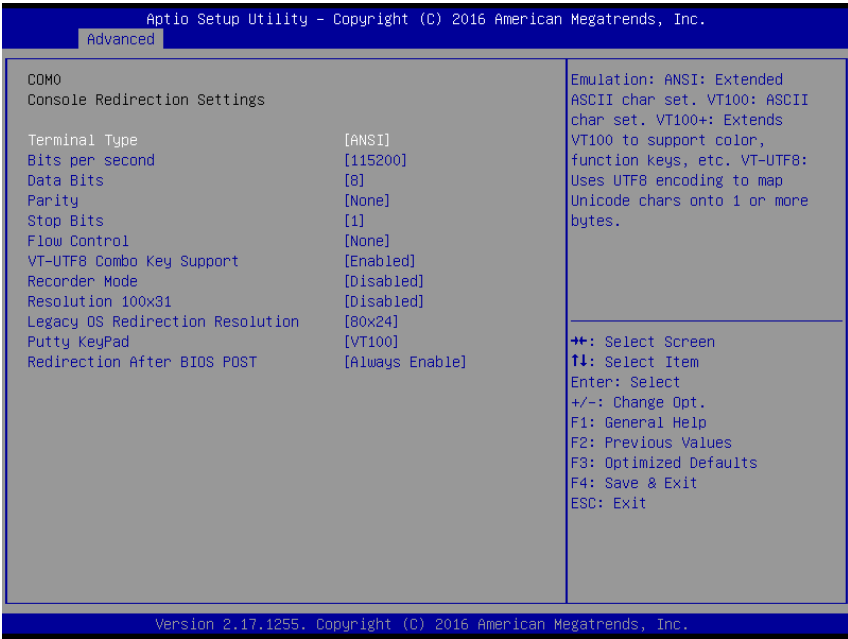

Options summary:

Terminal Type	VT100	Default
	VT100+	
	VT-UTF8	
	ANSI	
Bits per second	9600	Default
	19200	
	38400	
	57600	
	115200	
Data Bits	7	Default
	8	

Parity	None	Default
	Even	
	Odd	
	Mark	
	Space	
Stop Bits	1	Default
	2	
Flow Control	None	Default
	Hardware RTS/CTS	
VT-UTF8 Combo Key Support	Enabled	Default
	Disabled	
Recorder Mode	Enabled	Default
	Disabled	
Resolution 100x31	Enabled	Default
	Disabled	
Legacy OS Redirection Resolution	80x24	Default
	80x25	
Putty Keypad	VT100	Default
	LINUX	
	XTERMR6	
	SCO	
	ESCN	
	VT400	
Redirection After BIOS POST	Always Enabe	Default
	BootLoader	

3.4.4.2 Serial Port Console Redirection: Console Redirection Settings

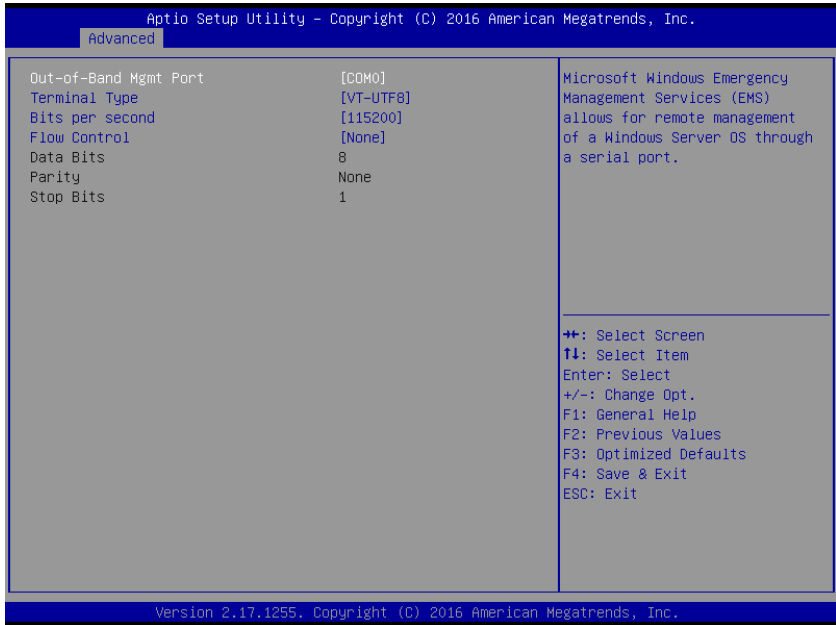

Options summary:

Out-of-Band Mgmt Port	COM0	Default
	COM1	
Terminal Type	VT100	Default
	VT100+	
	VT-UTF8	
	ANSI	
Bits per second	9600	Default
	19200	
	57600	
	115200	
Flow Control	None	Default
	Hardware RTS/CTS	
	Software Xon/Xoff	

3.4.5 Advanced: SIO Configuration

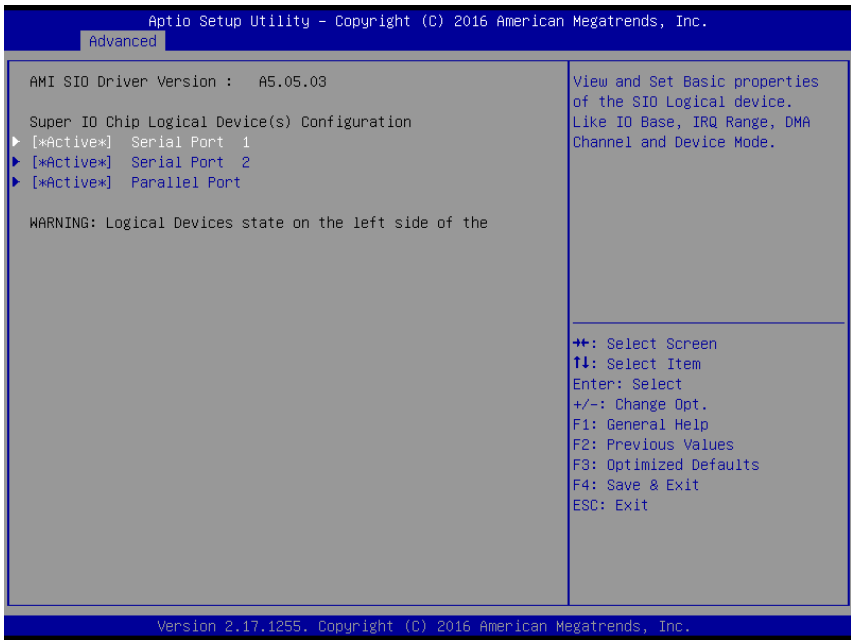

3.4.5.1 SIO Configuration: Serial Port1 Configuration

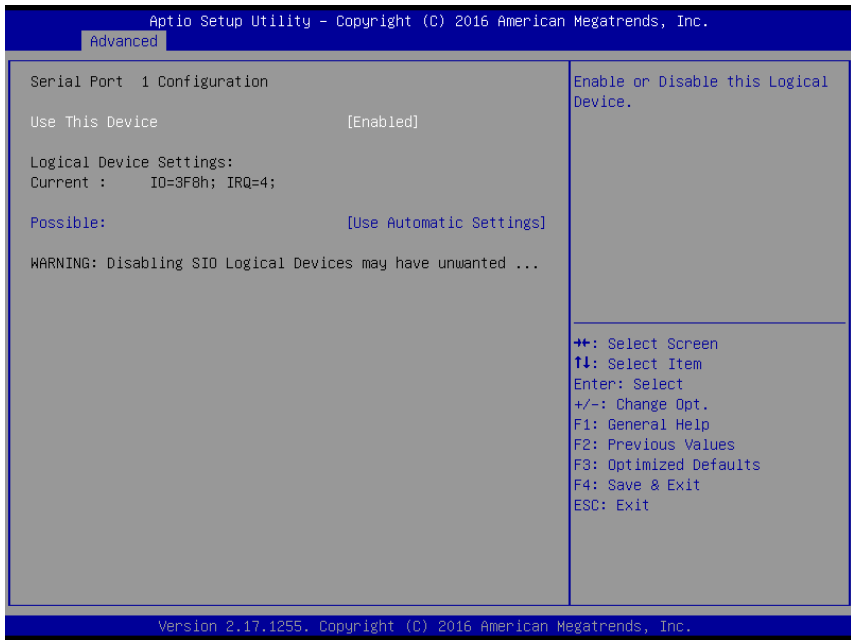

Options summary:

Use This Device	Disabled	Default
	Enabled	
Enable or Disable this Logical Device.		
Possible:		
Change Settings	Auto	Default
	IO=3F8h; IRQ=4;	
	IO=2F8h; IRQ=3;	
Allows user to change Device's Resource settings. New settings will be reflected on This Setup Page after System restarts.		

3.4.5.2 SIO Configuration: Serial Port2 Configuration

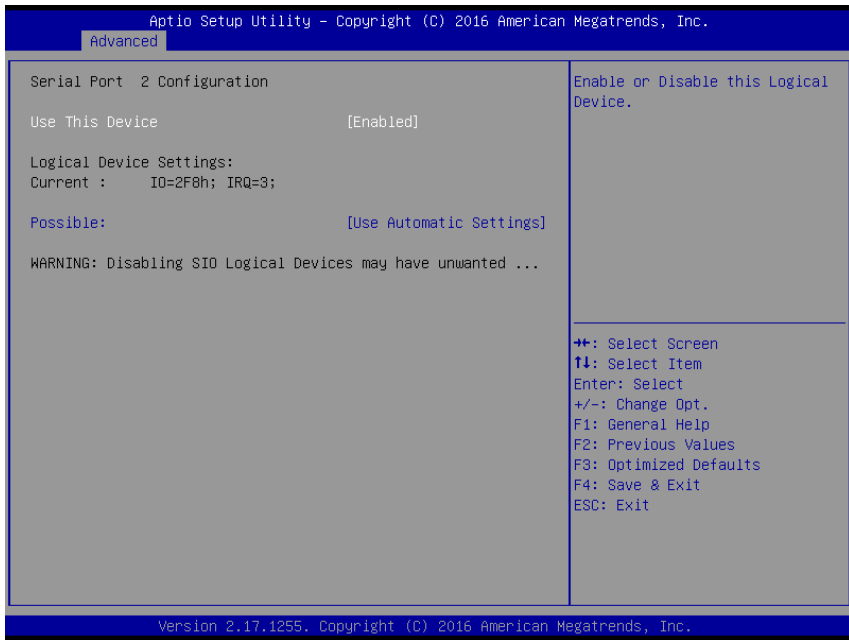

Options summary:

Use This Device	Disabled	Default
	Enabled	
Enable or Disable this Logical Device.		
Possible:		
Change Settings	Auto	Default
	IO=2F8h; IRQ=3;	
	IO=3F8h; IRQ=4;	
Allows user to change Device's Resource settings. New settings will be reflected on This Setup Page after System restarts.		

3.4.5.3 SIO Configuration: Parallel Port Configuration

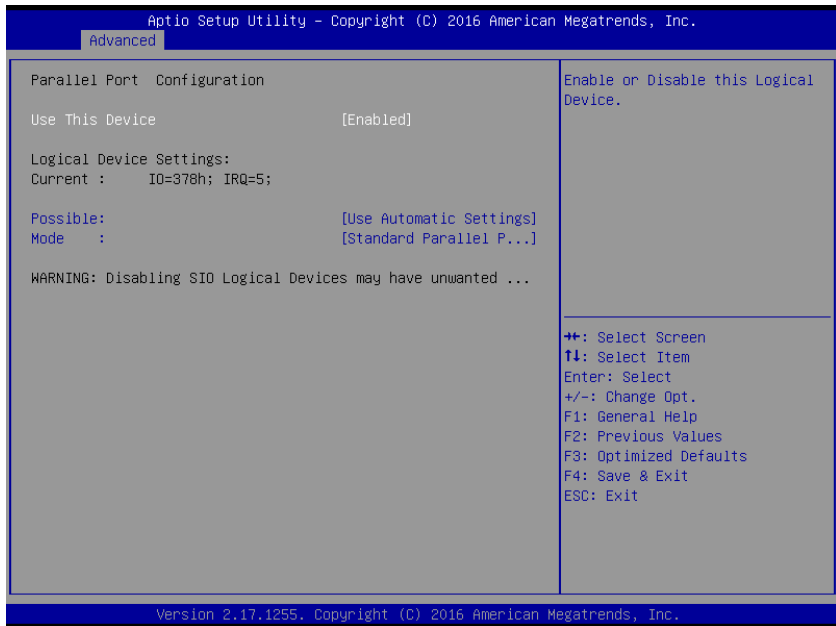

Options summary:

Use This Device	Disabled	Default
	Enabled	
Enable or Disable this Logical Device.		
Possible: (Parallel Port)	Auto	Default
	IO=378h; IRQ=5;	
	IO=378h; IRQ=5,6,7,9,10,11,12	
	IO=278h; IRQ=5,6,7,9,10,11,12	
	IO=3BCh; IRQ=5,6,7,9,10,11,12;	
Allows user to change Device's Resource settings. New settings will be reflected on This Setup Page after System restarts.		
Mode:	SPP Mode	Default
	EPP Mode	
	ECP Mode	
	ECP mode & ECP mode	
Change the Printer Port mode.		

3.4.6 Advanced: USB Configuration

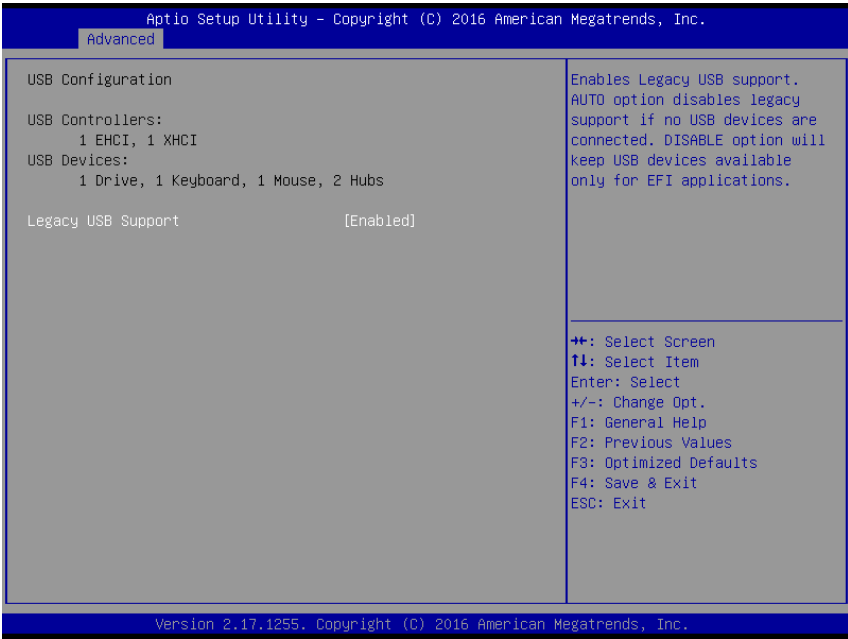

Options summary:

Legacy USB Support	Enabled	Default
	Disabled	
	Auto	
Enables BIOS Support for Legacy USB Support. When enabled, USB can be functional in legacy environment like DOS. AUTO option disables legacy support if no USB devices are connected		

3.4.7 Advanced: Digital IO Port Configuration

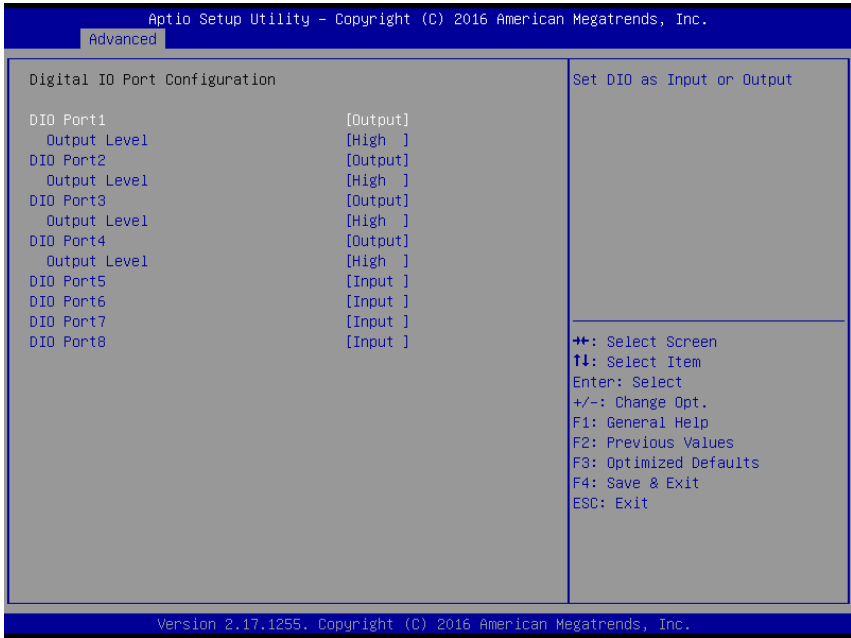

Options summary:

DIO_P#1~4	Input	Default
	Output	
Allows BIOS to select input/output function to corresponding DIO ping.		
DIO_P#5~8	Input	Default
	Output	
Allows BIOS to select input/output function to corresponding DIO ping.		
DIO_P#1~4 Direction	Low	Default
	Hi	
Allows BIOS to select high/low voltage level to output to corresponding DIO ping.		

3.4.8 Advanced: Power Management

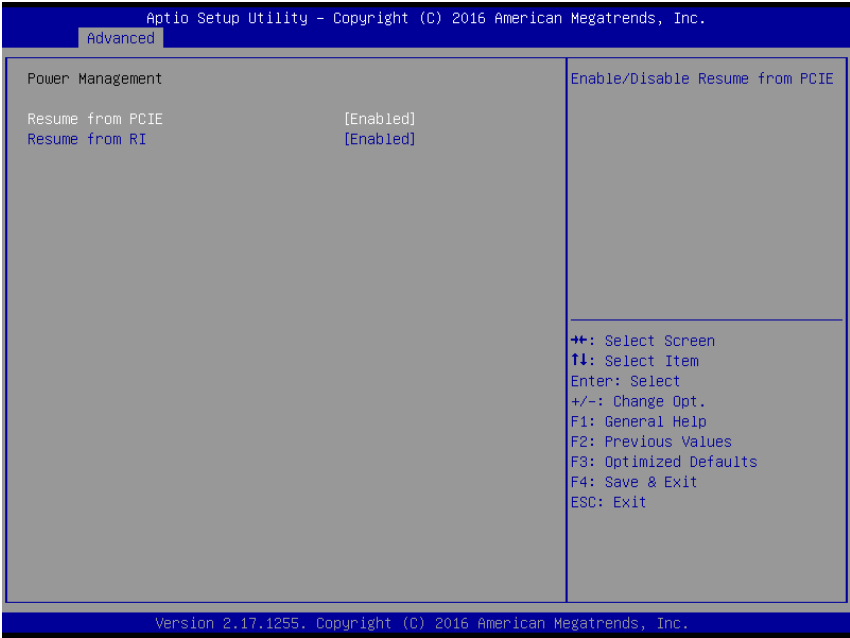

Options summary:

Resume from PCIE	Enabled	Default
	Disabled	
Enable/Disable Resume from PCIE.		
Resume from RI	Enabled	Default
	Disabled	
Enable/Disable Resume from Ring		

3.4.9 Advanced: LAN Bypass Configuration

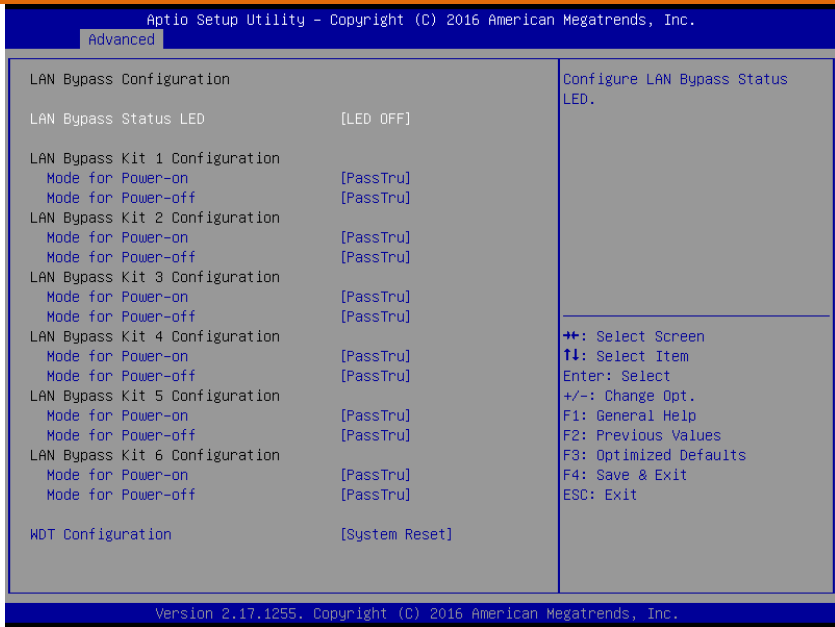

Options summary:

LAN Bypass Status LED Configuration	LED OFF	Default
	RED LED ON	
	RED LED BLINK	
	RED LED FAST BLINK	
	GREEN LED ON	
	GREEN LED BLINK	
	GREEN LED FAST BLINK	
LAN Bypass Kit Configuration		
Mode for power-on	PassTru	Default
	Bypass	
Mode for power-off	PassTru	Default
	Bypass	
WDT Configuration		
WDT Configuration	Force Bypass	Default
	System Reset	

3.5 Setup submenu: IntelRCSetup

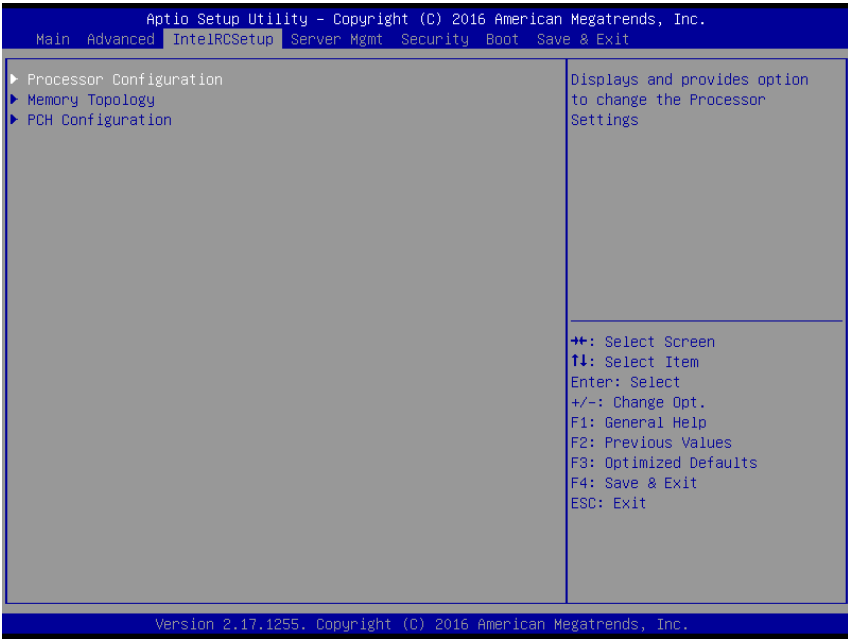

3.5.1 IntelRCSetup: Processor Configuration

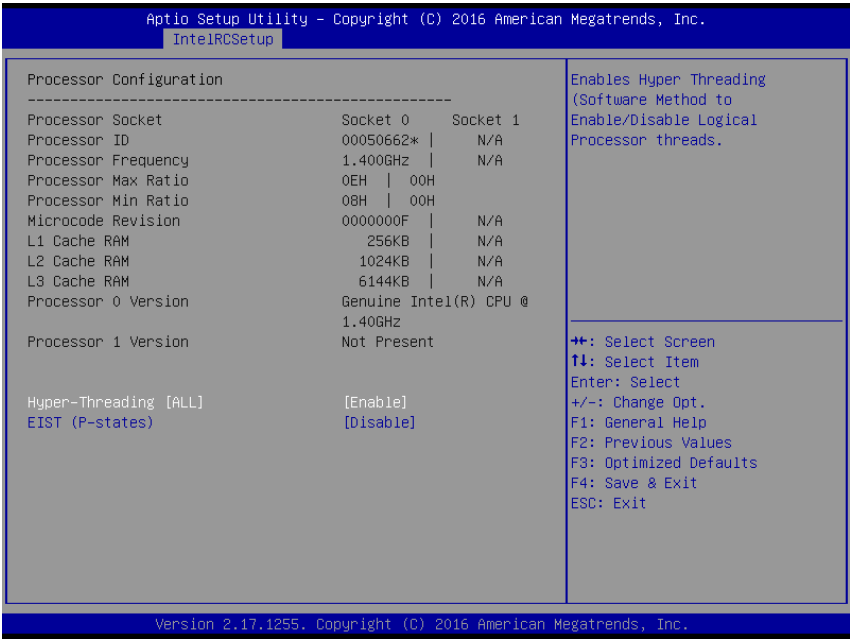

Options summary :

Hyper-threading[All]	Disabled	Default
	Enabled	
Enabled Hyper-Threading (Software Method to Enable/Disable Logical Processor threads.)		
EIST (P-states)	Disabled	Default
	Enabled	
When enabled, OS sets CPU frequency according load. When disabled, CPU frequency is set at max non-turbo.		

3.5.2 IntelRCSetup: Memory Configuration

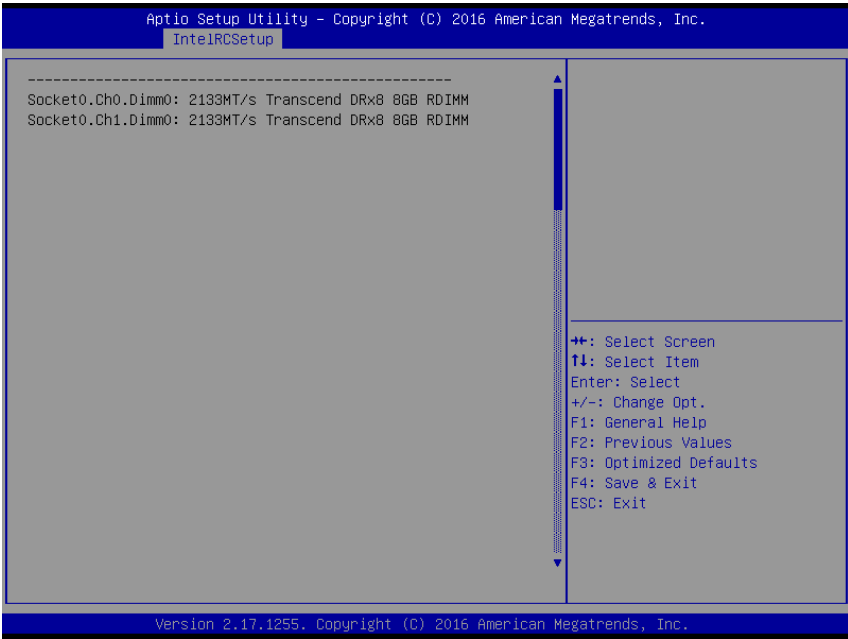

3.5.3 IntelRCSetup: PCH Configuration

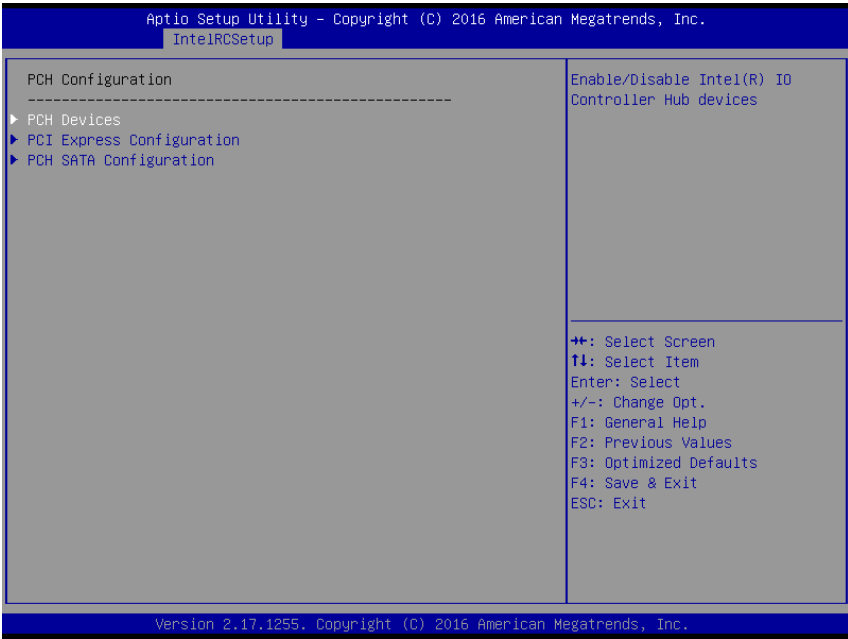

3.5.3.1 PCH Configuration: PCH Devices

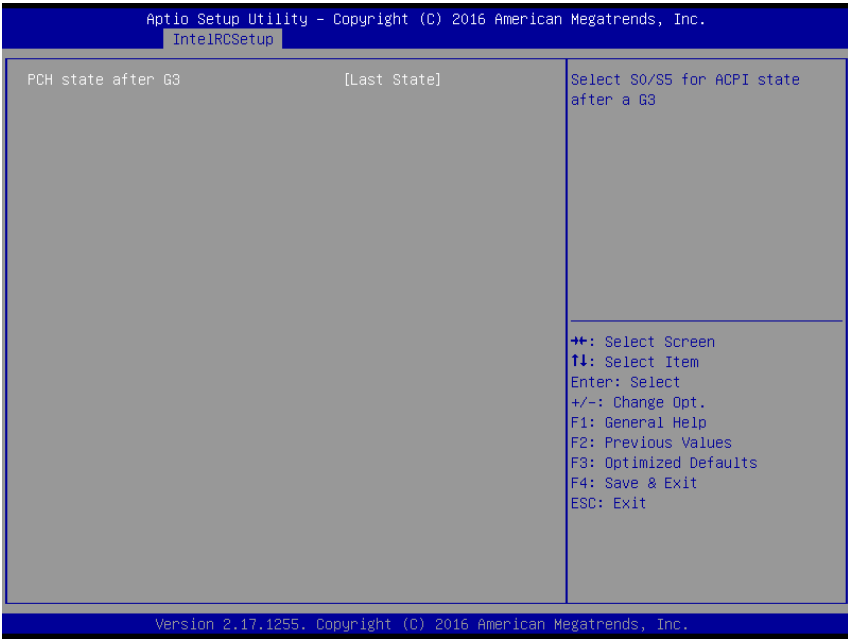

Options summary:

PCH state after G3	S0	Default
	S5	
	Last State	
Select AC power state when power is re-applied after a power failure.		

3.5.3.2 PCH Configuration: PCI Express Configuration

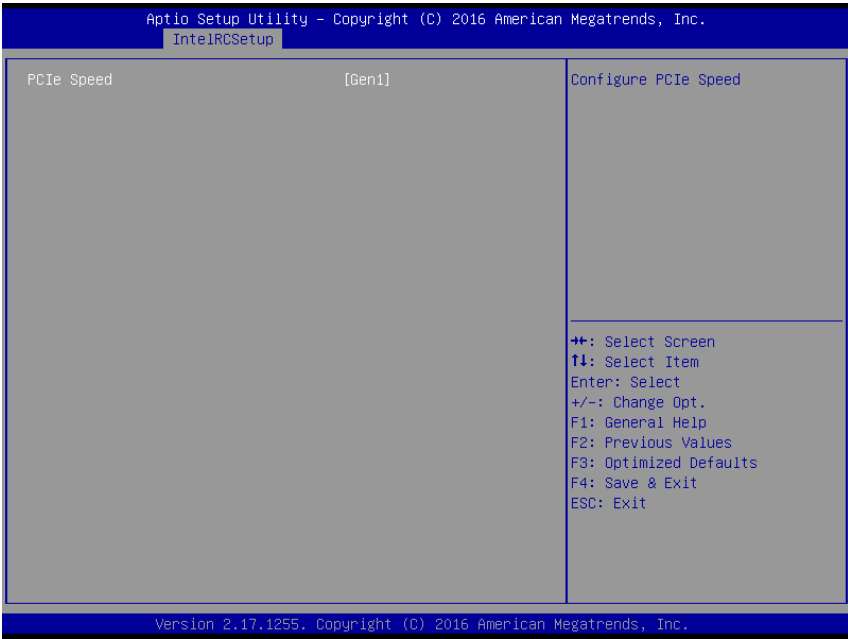

Options summary:

PCIe Speed	Auto	Default
	Gen1	
	Gen2	
Select PCI Express port 1 speed.		

3.5.3.3 PCH Configuration: SATA Configuration (IDE)

Aptio Setup Utility - Copyright (C) 2016 American Megatrends, Inc.
IntelRCSetup

PCH SATA Configuration

SATA Controller [Enabled]
Configure SATA as [IDE]

SATA Port 0 [Not Installed]
SATA Port 1 [Not Installed]
SATA Port 2 [Not Installed]
SATA Port 3 [Not Installed]
SATA Port 4 [Not Installed]
SATA Port 5 [Not Installed]

Identify the SATA port is connected to Solid State Drive or Hard Disk Drive

++: Select Screen
F1: Select Item
Enter: Select
+/-: Change Opt.
F1: General Help
F2: Previous Values
F3: Optimized Defaults
F4: Save & Exit
ESC: Exit

Version 2.17.1255. Copyright (C) 2016 American Megatrends, Inc.

3.5.3.4 PCH Configuration: SATA Configuration (AHCI)

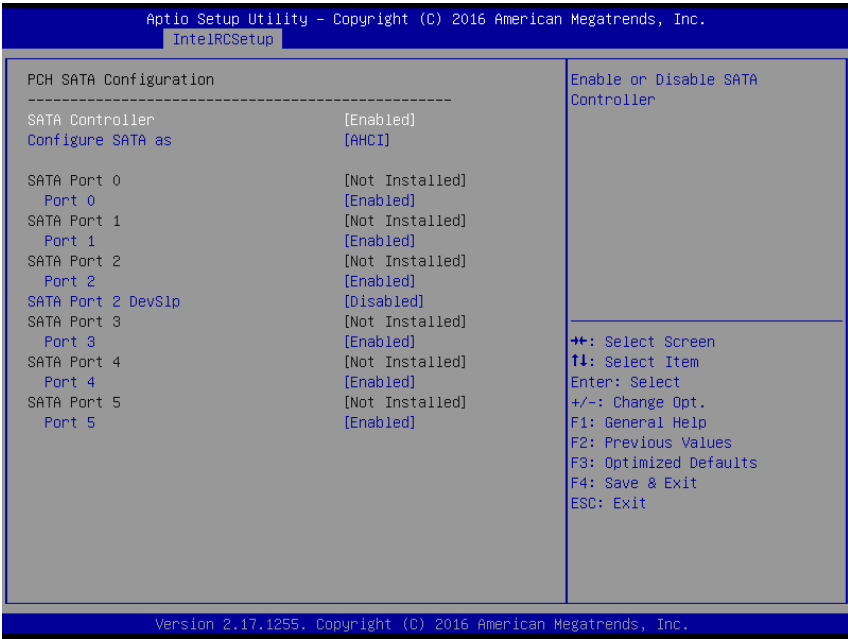

3.5.3.5 PCH Configuration: SATA Configuration (RAID)

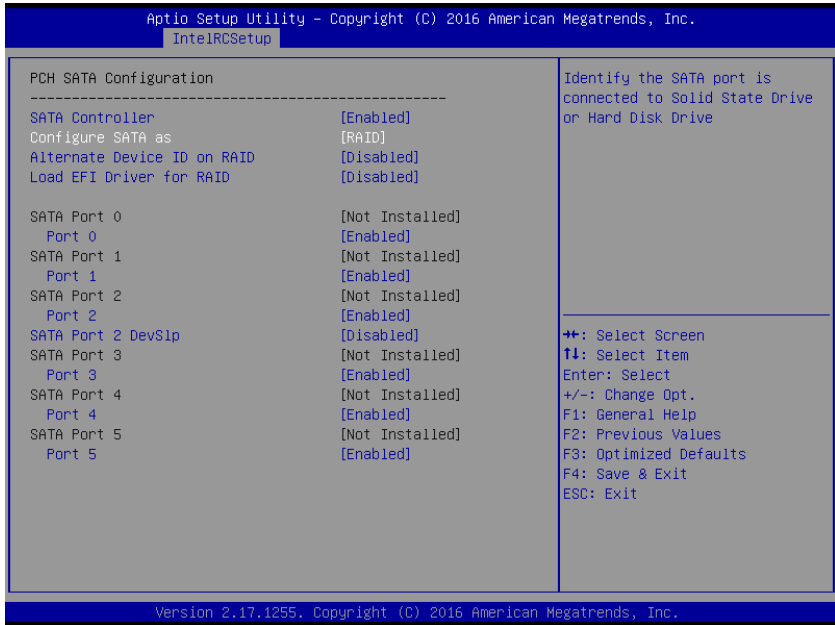

Options summary:

SATA Controllers	Disabled	Default
	Enabled	
En/Disable SATA Controller.		
SATA Mode	IDE	Default
	AHCI	
	RAID	
IDE: Configure SATA controllers as legacy IDEAHCI: Configure SATA controllers to operate in AHCI mode		
Alternate Device ID on RAID	Disabled	Default
	Enabled	
Enable alternate device ID on RAID devices.		
Load EFI Driver for RAID	Disabled	Default
	Enabled	
In RAID mode load EFI driver. (If disabled loads LEGACY OPROM).		
SATA Port	Disabled	Default
	Enabled	
En/Disable SATA Port.		

3.6 Setup submenu: Server Mgmt (Option)

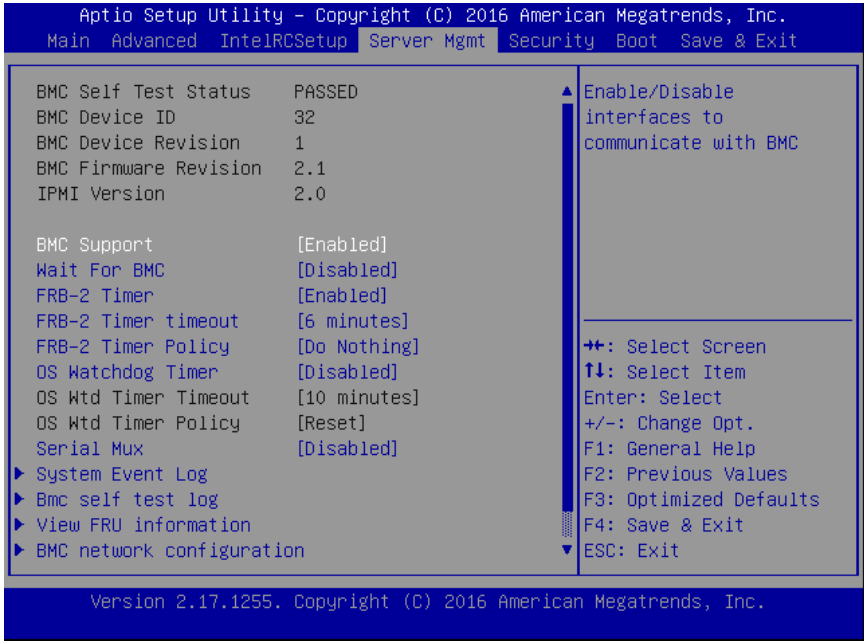

Options summary:

BMC Support	Disabled	Default
	Enabled	
En/Disable BMC controller.		
Wait For BMC	Disabled	Default
	Enabled	
Wait For BMC response for specified time out. In PILOTII, BMC starts at the same time when BIOS starts during AC power ON. It takes around 30 seconds to initialize Host to BMC interfaces.		
FRB-2 Timer	Disabled	Default
	Enabled	
Enable or Disable FRB-2 timer(POST timer)		
FRB-2 Timer timeout	3 minutes	Default
	4 minutes	
	5 minutes	
	6 minutes	
Enter value Between 3 to 6 min for FRB-2 Timer Expiration value		

FRB-2 Timer Policy	Do Nothing	Default
	Reset	
	Power Down	
	Power Cycle	
Configure how the system should respond if the FRB-2 Timer expires. Not available if FRB-2 Timer is disabled.		
OS Watchdog Timer	Disabled	Default
	Enabled	
If enabled, starts a BIOS timer which can only be shut off by Management Software after the OS loads. Helps determine that the OS successfully loaded or follows the OS Boot Watchdog Timer policy.		
OS Wtd Timer Timeout	5 minutes	Default
	10 minutes	
	15 minutes	
	20 minutes	
Configure the length of the OS Boot Watchdog Timer. Not available if OS Boot Watchdog Timer is disabled.		
OS Wtd Timer Policy	Do Nothing	Default
	Reset	
	Power Down	
	Power Cycle	
Configure how the system should respond if the OS Boot Watchdog Timer expires. Not available if OS Boot Watchdog Timer is disabled.		
Serial Mux	Disabled	Default
	Enabled	
Press <Enter> to enable or disable Serial Mux configuration.		

3.6.1 Server Mgmt: System Event Log

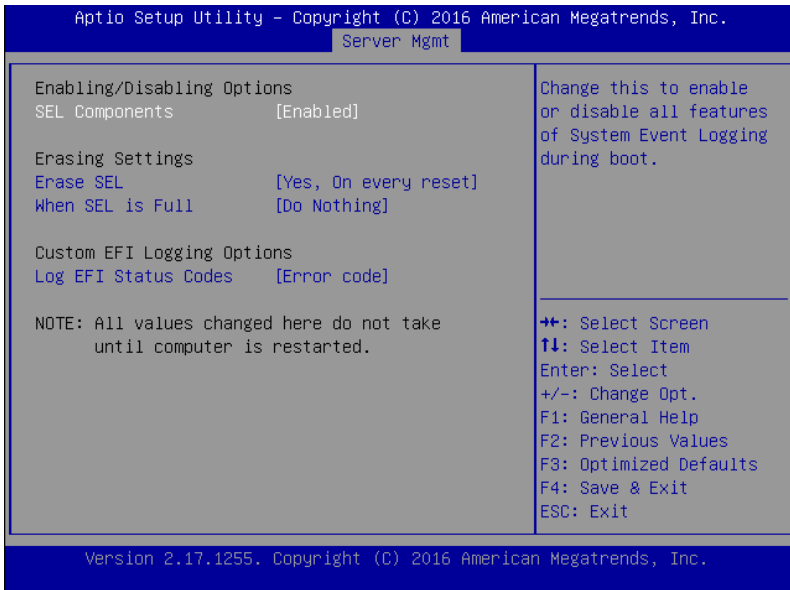

Options summary:

SEL Components	Disabled	Default
	Enabled	
Change this to enable or disable all features of System Event Logging during boot.		
Erase SEL	No	Default
	Yes, On next reset	
	Yes, On every reset	
Choose options for erasing SEL.		
When SEL is Full	Do Nothing	Default
	Erase Immediately	
Choose options for reactions to a full SEL.		
Log EFI Status Codes	Disabled	Default
	Both	
	Error code	
	Progress code	
Enable or disable the logging of EFI Status Codes (if not already converted to legacy).		

3.6.2 Server Mgmt: BMC self test log

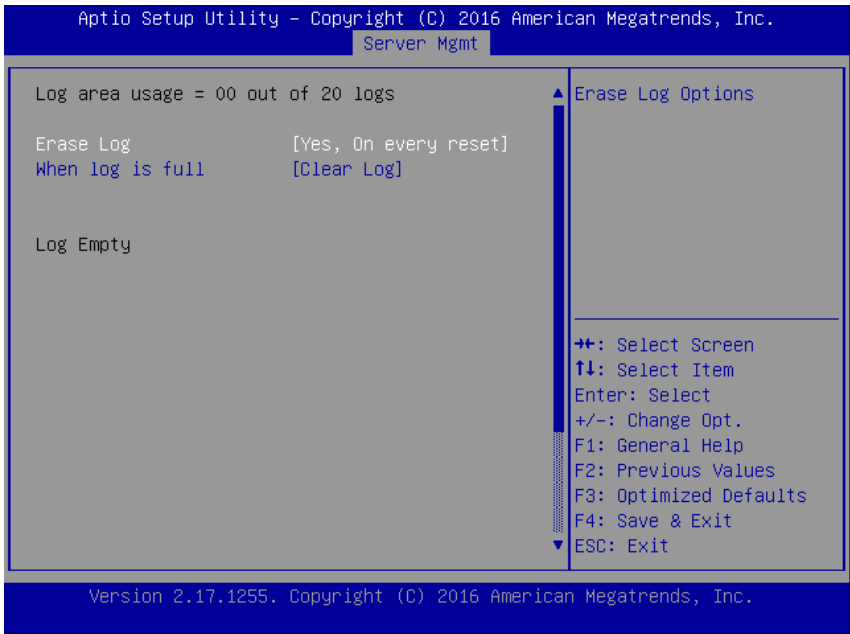

Options summary:

Erase Log	Yes, On every reset	Default
	No	
Erase Log options.		
When log is full	Clear Log	Default
	Do not log any more	
Select the action to be taken when log is full.		

3.6.2 Server Mgmt: View FRU information

Aptio Setup Utility - Copyright (C) 2016 American Megatrends, Inc.
Server Mgmt

FRU Information	
System Manufacturer	AAEON
System Product Name	FWB-7520
System Version	-
System Serial Number	-
Board Manufacturer	-
Board Product Name	FWB-7520
Board Version	-
Board Serial Number	-
Chassis Manufacturer	AAEON
Chassis Product Name	-
Chassis Serial Number	-
SDR Version	1.5
System UUID	-

++: Select Screen
↑↓: Select Item
Enter: Select
+/-: Change Opt.
F1: General Help
F2: Previous Values
F3: Optimized Defaults
F4: Save & Exit
ESC: Exit

Version 2.17.1255. Copyright (C) 2016 American Megatrends, Inc.

3.6.3 Server Mgmt: BMC network configuration

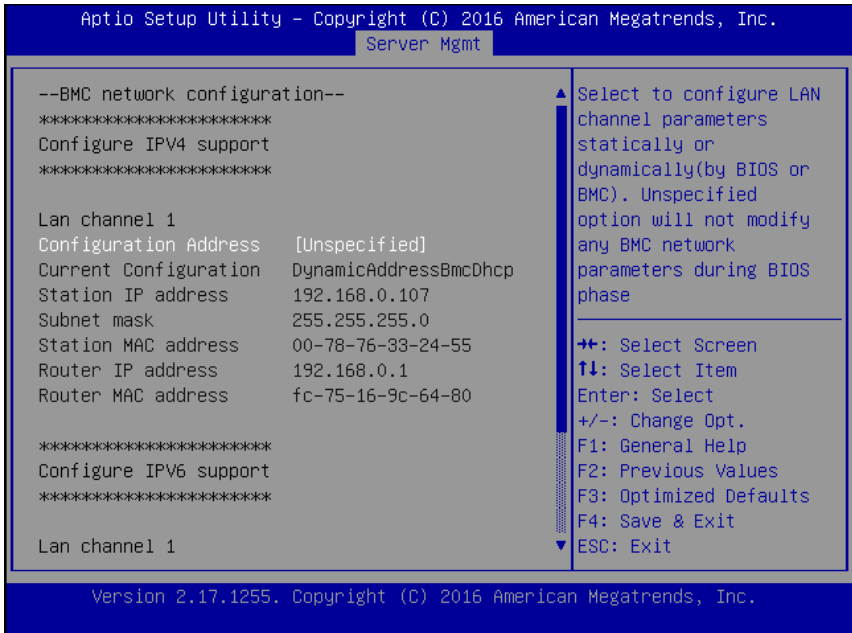

Options summary:

Configuration Address source	Unspecified	Default
	Static	
	DynamicBmcDhcp	
	DynamicBmcNonDhcp	

Select to configure LAN channel parameters statically or dynamically(by BIOS or BMC). Unspecified option will not modify any BMC network parameters during BIOS phase

3.6.3.1 BMC network configuration: View System Event Log

```
Aptio Setup Utility - Copyright (C) 2016 American Megatrends, Inc.
Server Mgmt

No. of log entries in SEL : 5
DATE      TIME      SENSOR TYPE
01/01/12  00:01:48  Event Logging Disabled
01/01/12  00:01:49  System Event
01/01/12  00:01:49  System Event
05/04/16  13:52:59  System Event
05/04/16  18:52:59  System Event

HEX:
06 00 02 6C A2 FF
4E 20 00 04 10 0D
6F 02 FF FF
Generator ID: BMC - LUN
#0 (Channel #0)
Sensor Number: 0x0D
Back Panel Board
Event Description: Log

++: Select Screen
↑↓: Select Item
Enter: Select
+/-: Change Opt.
F1: General Help
F2: Previous Values
F3: Optimized Defaults
F4: Save & Exit
ESC: Exit

Version 2.17.1255. Copyright (C) 2016 American Megatrends, Inc.
```

3.6.3.2 BMC network configuration: BMC User Settings

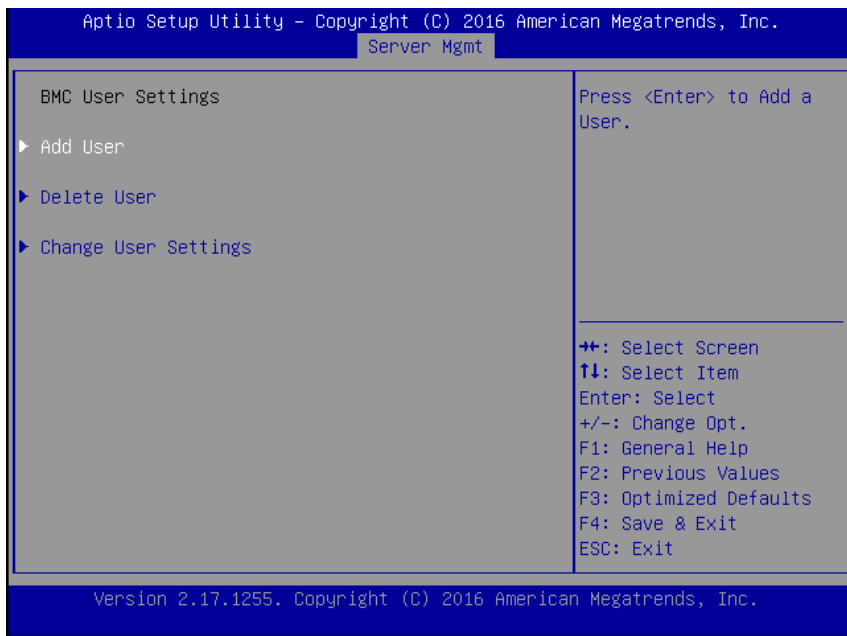

Options summary:

Add User	User Name	Default
	User Password	
	Channel No	
	User Privilege Limit	
Press <Enter> to add a User.		
Delete User	User Name	Default
	User Password	
Press <Enter> to delete a User.		
Change User Settings	User Name	Default
	User Password	
	User	
	ChangeUser Password	
	Channel No	
	User Privilege Limit	
Press <Enter> to change User Settings.		

3.7 Setup submenu: Security

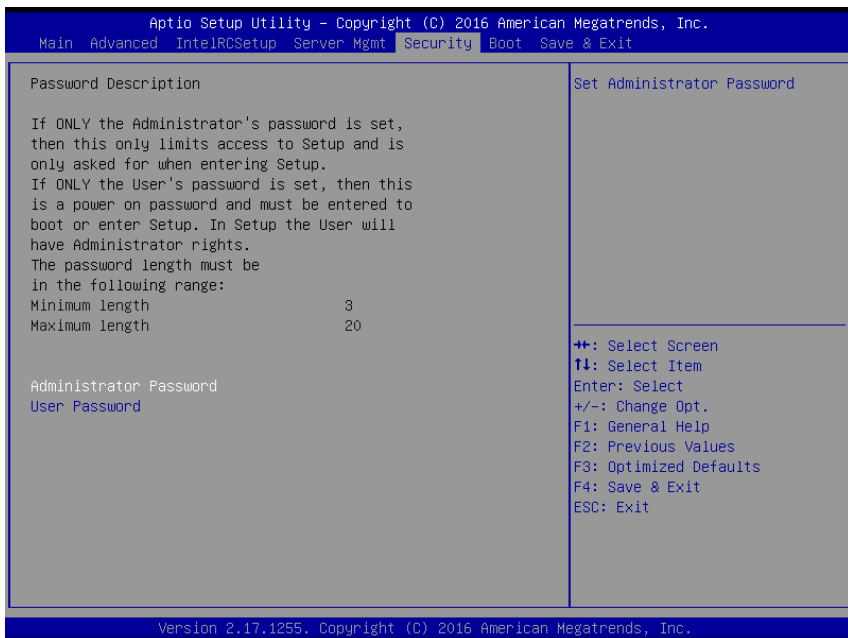

Change User/Administrator Password

You can set a User Password once an Administrator Password is set. The password will be required during boot up, or when the user enters the Setup utility. Please Note that a User Password does not provide access to many of the features in the Setup utility.

Select the password you wish to set, press Enter to open a dialog box to enter your password (you can enter no more than six letters or numbers). Press Enter to confirm your entry, after which you will be prompted to retype your password for a final confirmation. Press Enter again after you have retyped it correctly.

Removing the Password

Highlight this item and type in the current password. At the next dialog box press Enter to disable password protection.

3.8 Setup submenu: Boot

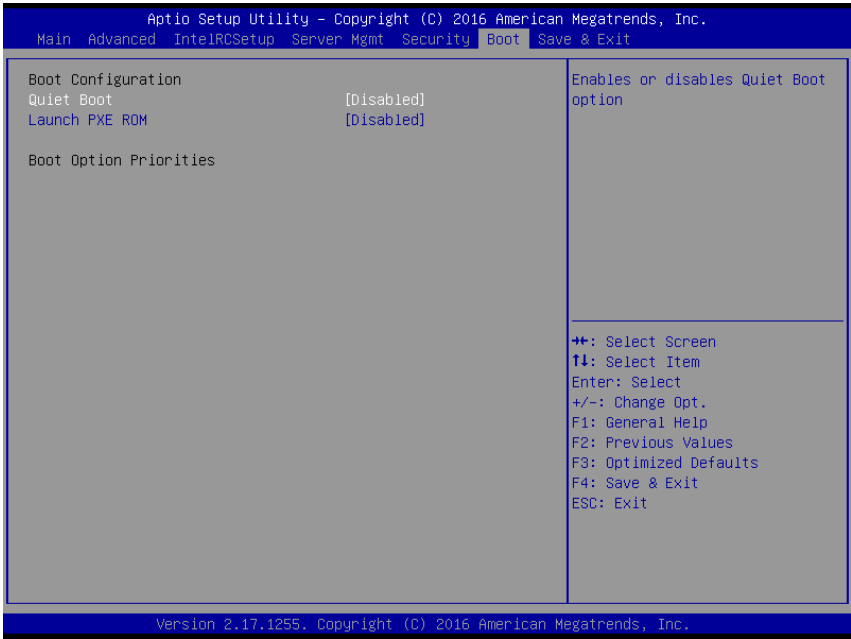

Options summary:

Quiet Boot	Disabled	Default
	Enabled	
En/Disable showing boot logo.		
Launch PXE OpROM	Disabled	Default
	Enabled	
En/Disable Legacy Boot Option.		

3.9 Setup submenu: Save & Exit

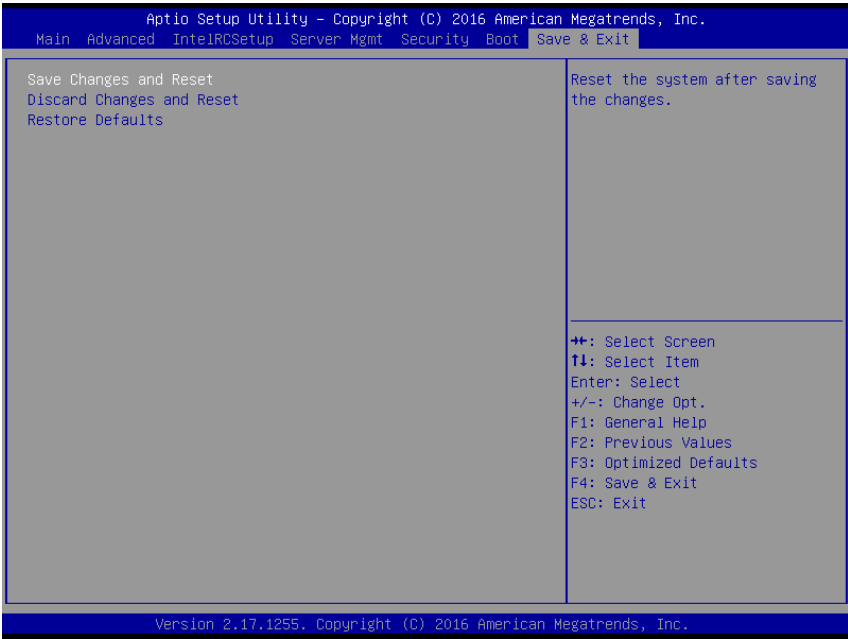

Chapter 4

Drivers Installation

4.1 Drivers Installation

Drivers for the FWS-7520 can be downloaded from the product page on the AAEON website by following this link:

<https://www.aaeon.com/en/p/rackmount-network-appliance-fws-7520>

Download the driver(s) you need and follow the steps below to install them.

Step 1 – Install Chipset Drivers

1. Open the **Step 1 - Chipset** folder followed by the **SetupChipset.exe** file
2. Follow the instructions
3. Drivers will be installed automatically

Step 2 – Install LAN Driver

1. Open the **Step 2 - LAN** folder and select your OS
2. Open the **.exe** file in the folder
3. Follow the instructions
4. Drivers will be installed automatically

Step 3 – Install USB3.0 Drivers

1. Open the **Step 3 – USB3.0** folder followed by the **Setup.exe** file
2. Follow the instructions
3. Drivers will be installed automatically

Appendix A

Watchdog Timer Programming

A.1 Watchdog Timer Initial Program

Table 1 : SuperIO relative register table		
	Default Value	Note
Index	0x2E(Note1)	SIO MB PnP Mode Index Register 0x2E or 0x4E
Data	0x2F(Note2)	SIO MB PnP Mode Data Register 0x2F or 0x4F

Table 2 : Watchdog relative register table					
	LDN	Register	BitNum	Value	Note
Timer Counter	0x07(Note3)	0x73(Note4)		(Note24)	Time of watchdog timer (0~255) This register is byte access
Counting Unit	0x07(Note5)	0x72(Note6)	7(Note7)	1(Note8)	Select time unit. 1: second 0: minute
Watchdog Enable (KRST)	0x07(Note9)	0x72(Note10)	4(Note11)	1(Note12)	0: Disable 1: Enable
Timeout Status	0x07(Note13)	0x71(Note14)	0(Note15)	1	1: Clear timeout status

```
*****
// SuperIO relative definition (Please reference to Table 1)
#define byte   SIOIndex //This parameter is represented from Note1
#define byte   SIOData //This parameter is represented from Note2
#define void   IOWriteByte(byte IOPort, byte Value);
#define byte   IOReadByte(byte IOPort);
// Watch Dog relative definition (Please reference to Table 2)
#define byte   TimerLDN //This parameter is represented from Note3
#define byte   TimerReg //This parameter is represented from Note4
#define byte   TimerVal // This parameter is represented from Note24
#define byte   UnitLDN //This parameter is represented from Note5
#define byte   UnitReg //This parameter is represented from Note6
#define byte   UnitBit //This parameter is represented from Note7
#define byte   UnitVal //This parameter is represented from Note8
#define byte   EnableLDN //This parameter is represented from Note9
#define byte   EnableReg //This parameter is represented from Note10
#define byte   EnableBit //This parameter is represented from Note11
#define byte   EnableVal //This parameter is represented from Note12
#define byte   StatusLDN // This parameter is represented from Note13
#define byte   StatusReg // This parameter is represented from Note14
#define byte   StatusBit // This parameter is represented from Note15
*****
```

```
*****
VOID Main(){
    // Procedure : AaeonWDTConfig
    // (byte)Timer : Time of WDT timer.(0x00~0xFF)
    // (boolean)Unit : Select time unit(0: second, 1: minute).
    AaeonWDTConfig();

    // Procedure : AaeonWDTEnable
    // This procedure will enable the WDT counting.
    AaeonWDTEnable();
}
*****
```

```
*****
// Procedure : AaeonWDTEnable
VOID  AaeonWDTEnable (){
    WDTEnableDisable(EnableLDN, EnableReg, EnableBit, 1);
}

// Procedure : AaeonWDTConfig
VOID  AaeonWDTConfig (){
    // Disable WDT counting
    WDTEnableDisable(EnableLDN, EnableReg, EnableBit, 0);
    // Clear Watchdog Timeout Status
    WDTClearTimeoutStatus();
    // WDT relative parameter setting
    WDTParameterSetting();
}

VOID  WDTEnableDisable(byte LDN, byte Register, byte BitNum, byte Value){
    SIOBitSet(LDN, Register, BitNum, Value);
}

VOID  WDTParameterSetting(){
    // Watchdog Timer counter setting
    SIOByteSet(TimerLDN, TimerReg, TimerVal);
    // WDT counting unit setting
    SIOBitSet(UnitLDN, UnitReg, UnitBit, UnitVal);
}

VOID  WDTClearTimeoutStatus(){
    SIOBitSet(StatusLDN, StatusReg, StatusBit, 1);
}
*****
```

```
*****
VOID SIOEnterMBPnPMode0{
    Switch(SIOIndex){
        Case 0x2E:
            IOWriteByte(SIOIndex, 0x87);
            IOWriteByte(SIOIndex, 0x01);
            IOWriteByte(SIOIndex, 0x55);
            IOWriteByte(SIOIndex, 0x55);
            Break;
        Case 0x4E:
            IOWriteByte(SIOIndex, 0x87);
            IOWriteByte(SIOIndex, 0x01);
            IOWriteByte(SIOIndex, 0x55);
            IOWriteByte(SIOIndex, 0xAA);
            Break;
    }
}

VOID SIOExitMBPnPMode0{
    IOWriteByte(SIOIndex, 0x02);
    IOWriteByte(SIOData, 0x02);
}

VOID SIOSelectLDN(byte LDN){
    IOWriteByte(SIOIndex, 0x07); // SIO LDN Register Offset = 0x07
    IOWriteByte(SIOData, LDN);
}
*****
```

```
*****
VOID  SIOBitSet(byte LDN, byte Register, byte BitNum, byte Value){
    Byte TmpValue;

    SIOEnterMBPnPMode();
    SIOSelectLDN(byte LDN);
    IOWriteByte(SIOIndex, Register);
    TmpValue = IOReadByte(SIOData);
    TmpValue &= ~(1 << BitNum);
    TmpValue |= (Value << BitNum);
    IOWriteByte(SIOData, TmpValue);
    SIOExitMBPnPMode();
}

VOID  SIOByteSet(byte LDN, byte Register, byte Value){
    SIOEnterMBPnPMode();
    SIOSelectLDN(LDN);
    IOWriteByte(SIOIndex, Register);
    IOWriteByte(SIOData, Value);
    SIOExitMBPnPMode();
}
*****
```







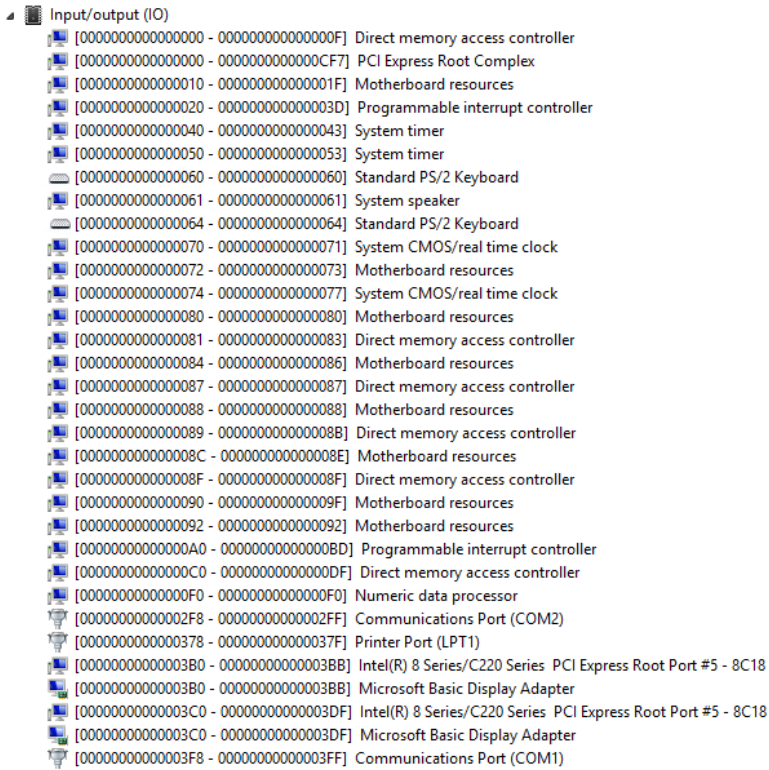



























Appendix B

I/O Information

B.1 I/O Address Map



Address	Device Name
[0000000000000000 - 000000000000000F]	Direct memory access controller
[0000000000000000 - 00000000000000CF]	PCI Express Root Complex
[0000000000000010 - 000000000000001F]	Motherboard resources
[0000000000000020 - 000000000000003D]	Programmable interrupt controller
[0000000000000040 - 0000000000000043]	System timer
[0000000000000050 - 0000000000000053]	System timer
[0000000000000060 - 0000000000000060]	Standard PS/2 Keyboard
[0000000000000061 - 0000000000000061]	System speaker
[0000000000000064 - 0000000000000064]	Standard PS/2 Keyboard
[0000000000000070 - 0000000000000071]	System CMOS/real time clock
[0000000000000072 - 0000000000000073]	Motherboard resources
[0000000000000074 - 0000000000000077]	System CMOS/real time clock
[0000000000000080 - 0000000000000080]	Motherboard resources
[0000000000000081 - 0000000000000083]	Direct memory access controller
[0000000000000084 - 0000000000000086]	Motherboard resources
[0000000000000087 - 0000000000000087]	Direct memory access controller
[0000000000000088 - 0000000000000088]	Motherboard resources
[0000000000000089 - 000000000000008B]	Direct memory access controller
[000000000000008C - 000000000000008E]	Motherboard resources
[000000000000008F - 000000000000008F]	Direct memory access controller
[0000000000000090 - 000000000000009F]	Motherboard resources
[0000000000000092 - 0000000000000092]	Motherboard resources
[00000000000000A0 - 00000000000000BD]	Programmable interrupt controller
[00000000000000C0 - 00000000000000DF]	Direct memory access controller
[00000000000000F0 - 00000000000000F0]	Numeric data processor
[00000000000002F8 - 00000000000002FF]	Communications Port (COM2)
[0000000000000378 - 000000000000037F]	Printer Port (LPT1)
[00000000000003B0 - 00000000000003BB]	Intel(R) 8 Series/C220 Series PCI Express Root Port #5 - 8C18
[00000000000003B0 - 00000000000003BB]	Microsoft Basic Display Adapter
[00000000000003C0 - 00000000000003DF]	Intel(R) 8 Series/C220 Series PCI Express Root Port #5 - 8C18
[00000000000003C0 - 00000000000003DF]	Microsoft Basic Display Adapter
[00000000000003F8 - 00000000000003FF]	Communications Port (COM1)

	[00000000000002F8 - 0000000000002FF] Communications Port (COM2)
	[0000000000000378 - 000000000000037F] Printer Port (LPT1)
	[00000000000003B0 - 00000000000003BB] Intel(R) 8 Series/C220 Series PCI Express Root Port #5 - 8C18
	[00000000000003B0 - 00000000000003BB] Microsoft Basic Display Adapter
	[00000000000003C0 - 00000000000003DF] Intel(R) 8 Series/C220 Series PCI Express Root Port #5 - 8C18
	[00000000000003C0 - 00000000000003DF] Microsoft Basic Display Adapter
	[00000000000003F8 - 00000000000003FF] Communications Port (COM1)
	[0000000000000400 - 000000000000047F] Motherboard resources
	[00000000000004D0 - 00000000000004D1] Programmable interrupt controller
	[0000000000000500 - 000000000000057F] Motherboard resources
	[0000000000000580 - 000000000000059F] Motherboard resources
	[0000000000000600 - 000000000000061F] Motherboard resources
	[0000000000000800 - 000000000000081F] Motherboard resources
	[0000000000000880 - 0000000000000883] Motherboard resources
	[0000000000000A00 - 0000000000000A2F] Motherboard resources
	[0000000000000A30 - 0000000000000A3F] Motherboard resources
	[0000000000000A40 - 0000000000000A4F] Motherboard resources
	[0000000000001000 - 000000000000FFFF] PCI Express Root Complex
	[000000000000D000 - 000000000000D00F] Standard Dual Channel PCI IDE Controller
	[000000000000D000 - 000000000000DFFF] Intel(R) 8 Series/C220 Series PCI Express Root Port #8 - 8C1E
	[000000000000D010 - 000000000000D013] Standard Dual Channel PCI IDE Controller
	[000000000000D020 - 000000000000D027] Standard Dual Channel PCI IDE Controller
	[000000000000D030 - 000000000000D033] Standard Dual Channel PCI IDE Controller
	[000000000000D040 - 000000000000D047] Standard Dual Channel PCI IDE Controller
	[000000000000E000 - 000000000000EFFF] Intel(R) 8 Series/C220 Series PCI Express Root Port #7 - 8C1C
	[000000000000F000 - 000000000000F01F] Intel(R) 8 Series/C220 Series SMBus Controller - 8C22
	[000000000000F020 - 000000000000F03F] Intel(R) 8 Series/C220 Series SATA AHCI Controller - 8C02
	[000000000000F040 - 000000000000F043] Intel(R) 8 Series/C220 Series SATA AHCI Controller - 8C02
	[000000000000F050 - 000000000000F057] Intel(R) 8 Series/C220 Series SATA AHCI Controller - 8C02
	[000000000000F060 - 000000000000F063] Intel(R) 8 Series/C220 Series SATA AHCI Controller - 8C02
	[000000000000F070 - 000000000000F077] Intel(R) 8 Series/C220 Series SATA AHCI Controller - 8C02
▶ 	Interrupt request (IRQ)
▶ 	Memory

B.2 Memory Address Map

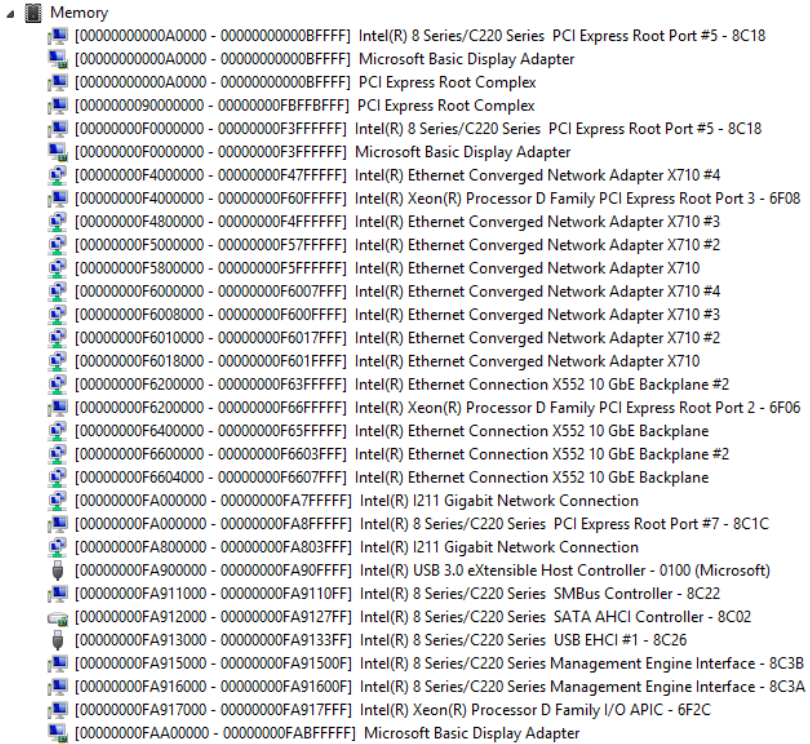

The screenshot displays the 'Memory' section of the Windows System Information tool. It lists various hardware components with their corresponding memory addresses and device names. The list includes:

































- Intel(R) 8 Series/C220 Series PCI Express Root Port #5 - 8C18
- Microsoft Basic Display Adapter
- PCI Express Root Complex
- Intel(R) 8 Series/C220 Series PCI Express Root Port #5 - 8C18
- Microsoft Basic Display Adapter
- Intel(R) Ethernet Converged Network Adapter X710 #4
- Intel(R) Xeon(R) Processor D Family PCI Express Root Port 3 - 6F08
- Intel(R) Ethernet Converged Network Adapter X710 #3
- Intel(R) Ethernet Converged Network Adapter X710 #2
- Intel(R) Ethernet Converged Network Adapter X710
- Intel(R) Ethernet Converged Network Adapter X710 #4
- Intel(R) Ethernet Converged Network Adapter X710 #3
- Intel(R) Ethernet Converged Network Adapter X710 #2
- Intel(R) Ethernet Converged Network Adapter X710
- Intel(R) Ethernet Connection X552 10 GbE Backplane #2
- Intel(R) Xeon(R) Processor D Family PCI Express Root Port 2 - 6F06
- Intel(R) Ethernet Connection X552 10 GbE Backplane
- Intel(R) Ethernet Connection X552 10 GbE Backplane #2
- Intel(R) Ethernet Connection X552 10 GbE Backplane
- Intel(R) I211 Gigabit Network Connection
- Intel(R) 8 Series/C220 Series PCI Express Root Port #7 - 8C1C
- Intel(R) I211 Gigabit Network Connection
- Intel(R) USB 3.0 eXtensible Host Controller - 0100 (Microsoft)
- Intel(R) 8 Series/C220 Series SMBus Controller - 8C22
- Intel(R) 8 Series/C220 Series SATA AHCI Controller - 8C02
- Intel(R) 8 Series/C220 Series USB EHCI #1 - 8C26
- Intel(R) 8 Series/C220 Series Management Engine Interface - 8C3B
- Intel(R) 8 Series/C220 Series Management Engine Interface - 8C3A
- Intel(R) Xeon(R) Processor D Family I/O APIC - 6F2C
- Microsoft Basic Display Adapter

[00000000FAA00000 - 00000000FACFFFFFF]	Intel(R) 8 Series/C220 Series PCI Express Root Port #5 - 8C18
[00000000FAE00000 - 00000000FAE7FFFF]	Intel(R) 82580 Gigabit Fiber Network Connection #8
[00000000FAE00000 - 00000000FB0FFFFFF]	Intel(R) Xeon(R) Processor D Family PCI Express Root Port 3 - 6F0B
[00000000FAE80000 - 00000000FAEFFFFFF]	Intel(R) 82580 Gigabit Fiber Network Connection #7
[00000000FAF00000 - 00000000FAF7FFFF]	Intel(R) 82580 Gigabit Fiber Network Connection #6
[00000000FAF80000 - 00000000FAFFFFFF]	Intel(R) 82580 Gigabit Fiber Network Connection #5
[00000000FB000000 - 00000000FB003FFF]	Intel(R) 82580 Gigabit Fiber Network Connection #8
[00000000FB004000 - 00000000FB007FFF]	Intel(R) 82580 Gigabit Fiber Network Connection #7
[00000000FB008000 - 00000000FB00BFFF]	Intel(R) 82580 Gigabit Fiber Network Connection #6
[00000000FB00C000 - 00000000FB00FFFF]	Intel(R) 82580 Gigabit Fiber Network Connection #5
[00000000FB100000 - 00000000FB17FFFF]	Intel(R) 82580 Gigabit Fiber Network Connection #4
[00000000FB100000 - 00000000FB3FFFFFF]	Intel(R) Xeon(R) Processor D Family PCI Express Root Port 3 - 6F0A
[00000000FB180000 - 00000000FB1FFFFFF]	Intel(R) 82580 Gigabit Fiber Network Connection #3
[00000000FB200000 - 00000000FB27FFFF]	Intel(R) 82580 Gigabit Fiber Network Connection #2
[00000000FB280000 - 00000000FB2FFFFFF]	Intel(R) 82580 Gigabit Fiber Network Connection
[00000000FB300000 - 00000000FB303FFF]	Intel(R) 82580 Gigabit Fiber Network Connection #4
[00000000FB304000 - 00000000FB307FFF]	Intel(R) 82580 Gigabit Fiber Network Connection #3
[00000000FB308000 - 00000000FB30BFFF]	Intel(R) 82580 Gigabit Fiber Network Connection #2
[00000000FB30C000 - 00000000FB30FFFF]	Intel(R) 82580 Gigabit Fiber Network Connection
[00000000FB400000 - 00000000FB5FFFFFF]	Intel(R) Xeon(R) Processor D Family PCI Express Root Port 3 - 6F08
[00000000FB600000 - 00000000FB6FFFFFF]	Intel(R) 8 Series/C220 Series PCI Express Root Port #8 - 8C1E
[00000000FB700000 - 00000000FB7FFFFFF]	Intel(R) Xeon(R) Processor D Family PCI Express Root Port 2 - 6F06
[00000000FB800000 - 00000000FB801FFF]	Intel(R) Xeon(R) Processor D Family QuickData Technology Registers - 6F53
[00000000FB800000 - 00000000FB8FFFFFF]	Intel(R) Xeon(R) Processor D Family PCI Express Root Port 2 - 6F04
[00000000FB802000 - 00000000FB803FFF]	Intel(R) Xeon(R) Processor D Family QuickData Technology Registers - 6F52
[00000000FB804000 - 00000000FB805FFF]	Intel(R) Xeon(R) Processor D Family QuickData Technology Registers - 6F51
[00000000FB806000 - 00000000FB807FFF]	Intel(R) Xeon(R) Processor D Family QuickData Technology Registers - 6F50
[00000000FEC00000 - 00000000FECFFFFFF]	Advanced programmable interrupt controller
[00000000FED00000 - 00000000FED003FF]	High precision event timer
[00000000FED12000 - 00000000FED1200F]	Motherboard resources
[00000000FED12010 - 00000000FED1201F]	Motherboard resources
[00000000FED1B000 - 00000000FED1BFFF]	Motherboard resources

































[00000000FAF80000 - 00000000FAFFFFFF]	Intel(R) 82580 Gigabit Fiber Network Connection #5
[00000000FB000000 - 00000000FB003FFF]	Intel(R) 82580 Gigabit Fiber Network Connection #8
[00000000FB004000 - 00000000FB007FFF]	Intel(R) 82580 Gigabit Fiber Network Connection #7
[00000000FB008000 - 00000000FB00BFFF]	Intel(R) 82580 Gigabit Fiber Network Connection #6
[00000000FB00C000 - 00000000FB00FFFF]	Intel(R) 82580 Gigabit Fiber Network Connection #5
[00000000FB100000 - 00000000FB17FFFF]	Intel(R) 82580 Gigabit Fiber Network Connection #4
[00000000FB100000 - 00000000FB3FFFFFF]	Intel(R) Xeon(R) Processor D Family PCI Express Root Port 3 - 6F0A
[00000000FB180000 - 00000000FB1FFFFFF]	Intel(R) 82580 Gigabit Fiber Network Connection #3
[00000000FB200000 - 00000000FB27FFFF]	Intel(R) 82580 Gigabit Fiber Network Connection #2
[00000000FB280000 - 00000000FB2FFFFFF]	Intel(R) 82580 Gigabit Fiber Network Connection
[00000000FB300000 - 00000000FB303FFF]	Intel(R) 82580 Gigabit Fiber Network Connection #4
[00000000FB304000 - 00000000FB307FFF]	Intel(R) 82580 Gigabit Fiber Network Connection #3
[00000000FB308000 - 00000000FB30BFFF]	Intel(R) 82580 Gigabit Fiber Network Connection #2
[00000000FB30C000 - 00000000FB30FFFF]	Intel(R) 82580 Gigabit Fiber Network Connection
[00000000FB400000 - 00000000FB5FFFFFF]	Intel(R) Xeon(R) Processor D Family PCI Express Root Port 3 - 6F08
[00000000FB600000 - 00000000FB6FFFFFF]	Intel(R) 8 Series/C220 Series PCI Express Root Port #8 - 8C1E
[00000000FB700000 - 00000000FB7FFFFFF]	Intel(R) Xeon(R) Processor D Family PCI Express Root Port 2 - 6F06
[00000000FB800000 - 00000000FB801FFF]	Intel(R) Xeon(R) Processor D Family QuickData Technology Registers - 6F53
[00000000FB800000 - 00000000FB8FFFFFF]	Intel(R) Xeon(R) Processor D Family PCI Express Root Port 2 - 6F04
[00000000FB802000 - 00000000FB803FFF]	Intel(R) Xeon(R) Processor D Family QuickData Technology Registers - 6F52
[00000000FB804000 - 00000000FB805FFF]	Intel(R) Xeon(R) Processor D Family QuickData Technology Registers - 6F51
[00000000FB806000 - 00000000FB807FFF]	Intel(R) Xeon(R) Processor D Family QuickData Technology Registers - 6F50
[00000000FEC00000 - 00000000FECFFFFFF]	Advanced programmable interrupt controller
[00000000FED00000 - 00000000FED003FF]	High precision event timer
[00000000FED12000 - 00000000FED1200F]	Motherboard resources
[00000000FED12010 - 00000000FED1201F]	Motherboard resources
[00000000FED1B000 - 00000000FED1BFFF]	Motherboard resources
[00000000FED1C000 - 00000000FED3FFFF]	Motherboard resources
[00000000FED40000 - 00000000FED44FFF]	Trusted Platform Module 1.2
[00000000FED45000 - 00000000FED8BFFF]	Motherboard resources
[00000000FEE00000 - 00000000FEEFFFFFF]	Motherboard resources
[00000000FF000000 - 00000000FFFFFFFF]	Motherboard resources

B.3 IRQ Mapping Chart

































▶ FWS-7520	
▶ Direct memory access (DMA)	
▶ Input/output (IO)	
▶ Interrupt request (IRQ)	
▶ (ISA) 0x00000000 (00)	System timer
▶ (ISA) 0x00000001 (01)	Standard PS/2 Keyboard
▶ (ISA) 0x00000003 (03)	Communications Port (COM2)
▶ (ISA) 0x00000004 (04)	Communications Port (COM1)
▶ (ISA) 0x00000008 (08)	System CMOS/real time clock
▶ (ISA) 0x0000000C (12)	PS/2 Compatible Mouse
▶ (ISA) 0x0000000D (13)	Numeric data processor
▶ (ISA) 0x00000051 (81)	Microsoft ACPI-Compliant System
▶ (ISA) 0x00000052 (82)	Microsoft ACPI-Compliant System
▶ (ISA) 0x00000053 (83)	Microsoft ACPI-Compliant System
▶ (ISA) 0x00000054 (84)	Microsoft ACPI-Compliant System
▶ (ISA) 0x00000055 (85)	Microsoft ACPI-Compliant System
▶ (ISA) 0x00000056 (86)	Microsoft ACPI-Compliant System
▶ (ISA) 0x00000057 (87)	Microsoft ACPI-Compliant System
▶ (ISA) 0x00000058 (88)	Microsoft ACPI-Compliant System
▶ (ISA) 0x00000059 (89)	Microsoft ACPI-Compliant System
▶ (ISA) 0x0000005A (90)	Microsoft ACPI-Compliant System
▶ (ISA) 0x0000005B (91)	Microsoft ACPI-Compliant System
▶ (ISA) 0x0000005C (92)	Microsoft ACPI-Compliant System
▶ (ISA) 0x0000005D (93)	Microsoft ACPI-Compliant System
▶ (ISA) 0x0000005E (94)	Microsoft ACPI-Compliant System
▶ (ISA) 0x0000005F (95)	Microsoft ACPI-Compliant System
▶ (ISA) 0x00000060 (96)	Microsoft ACPI-Compliant System
▶ (ISA) 0x00000061 (97)	Microsoft ACPI-Compliant System
▶ (ISA) 0x00000062 (98)	Microsoft ACPI-Compliant System
▶ (ISA) 0x00000063 (99)	Microsoft ACPI-Compliant System
▶ (ISA) 0x00000064 (100)	Microsoft ACPI-Compliant System
▶ (ISA) 0x00000065 (101)	Microsoft ACPI-Compliant System
▶ (ISA) 0x00000066 (102)	Microsoft ACPI-Compliant System

 (ISA) 0x00000067 (103)	Microsoft ACPI-Compliant System
 (ISA) 0x00000068 (104)	Microsoft ACPI-Compliant System
 (ISA) 0x00000069 (105)	Microsoft ACPI-Compliant System
 (ISA) 0x0000006A (106)	Microsoft ACPI-Compliant System
 (ISA) 0x0000006B (107)	Microsoft ACPI-Compliant System
 (ISA) 0x0000006C (108)	Microsoft ACPI-Compliant System
 (ISA) 0x0000006D (109)	Microsoft ACPI-Compliant System
 (ISA) 0x0000006E (110)	Microsoft ACPI-Compliant System
 (ISA) 0x0000006F (111)	Microsoft ACPI-Compliant System
 (ISA) 0x00000070 (112)	Microsoft ACPI-Compliant System
 (ISA) 0x00000071 (113)	Microsoft ACPI-Compliant System
 (ISA) 0x00000072 (114)	Microsoft ACPI-Compliant System
 (ISA) 0x00000073 (115)	Microsoft ACPI-Compliant System
 (ISA) 0x00000074 (116)	Microsoft ACPI-Compliant System
 (ISA) 0x00000075 (117)	Microsoft ACPI-Compliant System
 (ISA) 0x00000076 (118)	Microsoft ACPI-Compliant System
 (ISA) 0x00000077 (119)	Microsoft ACPI-Compliant System
 (ISA) 0x00000078 (120)	Microsoft ACPI-Compliant System
 (ISA) 0x00000079 (121)	Microsoft ACPI-Compliant System
 (ISA) 0x0000007A (122)	Microsoft ACPI-Compliant System
 (ISA) 0x0000007B (123)	Microsoft ACPI-Compliant System
 (ISA) 0x0000007C (124)	Microsoft ACPI-Compliant System
 (ISA) 0x0000007D (125)	Microsoft ACPI-Compliant System
 (ISA) 0x0000007E (126)	Microsoft ACPI-Compliant System
 (ISA) 0x0000007F (127)	Microsoft ACPI-Compliant System
 (ISA) 0x00000080 (128)	Microsoft ACPI-Compliant System
 (ISA) 0x00000081 (129)	Microsoft ACPI-Compliant System
 (ISA) 0x00000082 (130)	Microsoft ACPI-Compliant System
 (ISA) 0x00000083 (131)	Microsoft ACPI-Compliant System
 (ISA) 0x00000084 (132)	Microsoft ACPI-Compliant System
 (ISA) 0x00000085 (133)	Microsoft ACPI-Compliant System
 (ISA) 0x00000086 (134)	Microsoft ACPI-Compliant System
 (ISA) 0x00000087 (135)	Microsoft ACPI-Compliant System



































 (ISA) 0x00000088 (136)	Microsoft ACPI-Compliant System
 (ISA) 0x00000089 (137)	Microsoft ACPI-Compliant System
 (ISA) 0x0000008A (138)	Microsoft ACPI-Compliant System
 (ISA) 0x0000008B (139)	Microsoft ACPI-Compliant System
 (ISA) 0x0000008C (140)	Microsoft ACPI-Compliant System
 (ISA) 0x0000008D (141)	Microsoft ACPI-Compliant System
 (ISA) 0x0000008E (142)	Microsoft ACPI-Compliant System
 (ISA) 0x0000008F (143)	Microsoft ACPI-Compliant System
 (ISA) 0x00000090 (144)	Microsoft ACPI-Compliant System
 (ISA) 0x00000091 (145)	Microsoft ACPI-Compliant System
 (ISA) 0x00000092 (146)	Microsoft ACPI-Compliant System
 (ISA) 0x00000093 (147)	Microsoft ACPI-Compliant System
 (ISA) 0x00000094 (148)	Microsoft ACPI-Compliant System
 (ISA) 0x00000095 (149)	Microsoft ACPI-Compliant System
 (ISA) 0x00000096 (150)	Microsoft ACPI-Compliant System
 (ISA) 0x00000097 (151)	Microsoft ACPI-Compliant System
 (ISA) 0x00000098 (152)	Microsoft ACPI-Compliant System
 (ISA) 0x00000099 (153)	Microsoft ACPI-Compliant System
 (ISA) 0x0000009A (154)	Microsoft ACPI-Compliant System
 (ISA) 0x0000009B (155)	Microsoft ACPI-Compliant System
 (ISA) 0x0000009C (156)	Microsoft ACPI-Compliant System
 (ISA) 0x0000009D (157)	Microsoft ACPI-Compliant System
 (ISA) 0x0000009E (158)	Microsoft ACPI-Compliant System
 (ISA) 0x0000009F (159)	Microsoft ACPI-Compliant System
 (ISA) 0x000000A0 (160)	Microsoft ACPI-Compliant System
 (ISA) 0x000000A1 (161)	Microsoft ACPI-Compliant System
 (ISA) 0x000000A2 (162)	Microsoft ACPI-Compliant System
 (ISA) 0x000000A3 (163)	Microsoft ACPI-Compliant System
 (ISA) 0x000000A4 (164)	Microsoft ACPI-Compliant System
 (ISA) 0x000000A5 (165)	Microsoft ACPI-Compliant System
 (ISA) 0x000000A6 (166)	Microsoft ACPI-Compliant System
 (ISA) 0x000000A7 (167)	Microsoft ACPI-Compliant System
 (ISA) 0x000000A8 (168)	Microsoft ACPI-Compliant System



































 (ISA) 0x000000A9 (169)	Microsoft ACPI-Compliant System
 (ISA) 0x000000AA (170)	Microsoft ACPI-Compliant System
 (ISA) 0x000000AB (171)	Microsoft ACPI-Compliant System
 (ISA) 0x000000AC (172)	Microsoft ACPI-Compliant System
 (ISA) 0x000000AD (173)	Microsoft ACPI-Compliant System
 (ISA) 0x000000AE (174)	Microsoft ACPI-Compliant System
 (ISA) 0x000000AF (175)	Microsoft ACPI-Compliant System
 (ISA) 0x000000B0 (176)	Microsoft ACPI-Compliant System
 (ISA) 0x000000B1 (177)	Microsoft ACPI-Compliant System
 (ISA) 0x000000B2 (178)	Microsoft ACPI-Compliant System
 (ISA) 0x000000B3 (179)	Microsoft ACPI-Compliant System
 (ISA) 0x000000B4 (180)	Microsoft ACPI-Compliant System
 (ISA) 0x000000B5 (181)	Microsoft ACPI-Compliant System
 (ISA) 0x000000B6 (182)	Microsoft ACPI-Compliant System
 (ISA) 0x000000B7 (183)	Microsoft ACPI-Compliant System
 (ISA) 0x000000B8 (184)	Microsoft ACPI-Compliant System
 (ISA) 0x000000B9 (185)	Microsoft ACPI-Compliant System
 (ISA) 0x000000BA (186)	Microsoft ACPI-Compliant System
 (ISA) 0x000000BB (187)	Microsoft ACPI-Compliant System
 (ISA) 0x000000BC (188)	Microsoft ACPI-Compliant System
 (ISA) 0x000000BD (189)	Microsoft ACPI-Compliant System
 (ISA) 0x000000BE (190)	Microsoft ACPI-Compliant System
 (ISA) 0x000000BF (191)	Microsoft ACPI-Compliant System
 (ISA) 0x00000100 (256)	Microsoft ACPI-Compliant System
 (ISA) 0x00000101 (257)	Microsoft ACPI-Compliant System
 (ISA) 0x00000102 (258)	Microsoft ACPI-Compliant System
 (ISA) 0x00000103 (259)	Microsoft ACPI-Compliant System
 (ISA) 0x00000104 (260)	Microsoft ACPI-Compliant System
 (ISA) 0x00000105 (261)	Microsoft ACPI-Compliant System
 (ISA) 0x00000106 (262)	Microsoft ACPI-Compliant System
 (ISA) 0x00000107 (263)	Microsoft ACPI-Compliant System
 (ISA) 0x00000108 (264)	Microsoft ACPI-Compliant System
 (ISA) 0x00000109 (265)	Microsoft ACPI-Compliant System



































 (ISA) 0x0000010A (266)	Microsoft ACPI-Compliant System
 (ISA) 0x0000010B (267)	Microsoft ACPI-Compliant System
 (ISA) 0x0000010C (268)	Microsoft ACPI-Compliant System
 (ISA) 0x0000010D (269)	Microsoft ACPI-Compliant System
 (ISA) 0x0000010E (270)	Microsoft ACPI-Compliant System
 (ISA) 0x0000010F (271)	Microsoft ACPI-Compliant System
 (ISA) 0x00000110 (272)	Microsoft ACPI-Compliant System
 (ISA) 0x00000111 (273)	Microsoft ACPI-Compliant System
 (ISA) 0x00000112 (274)	Microsoft ACPI-Compliant System
 (ISA) 0x00000113 (275)	Microsoft ACPI-Compliant System
 (ISA) 0x00000114 (276)	Microsoft ACPI-Compliant System
 (ISA) 0x00000115 (277)	Microsoft ACPI-Compliant System
 (ISA) 0x00000116 (278)	Microsoft ACPI-Compliant System
 (ISA) 0x00000117 (279)	Microsoft ACPI-Compliant System
 (ISA) 0x00000118 (280)	Microsoft ACPI-Compliant System
 (ISA) 0x00000119 (281)	Microsoft ACPI-Compliant System
 (ISA) 0x0000011A (282)	Microsoft ACPI-Compliant System
 (ISA) 0x0000011B (283)	Microsoft ACPI-Compliant System
 (ISA) 0x0000011C (284)	Microsoft ACPI-Compliant System
 (ISA) 0x0000011D (285)	Microsoft ACPI-Compliant System
 (ISA) 0x0000011E (286)	Microsoft ACPI-Compliant System
 (ISA) 0x0000011F (287)	Microsoft ACPI-Compliant System
 (ISA) 0x00000120 (288)	Microsoft ACPI-Compliant System
 (ISA) 0x00000121 (289)	Microsoft ACPI-Compliant System
 (ISA) 0x00000122 (290)	Microsoft ACPI-Compliant System
 (ISA) 0x00000123 (291)	Microsoft ACPI-Compliant System
 (ISA) 0x00000124 (292)	Microsoft ACPI-Compliant System
 (ISA) 0x00000125 (293)	Microsoft ACPI-Compliant System
 (ISA) 0x00000126 (294)	Microsoft ACPI-Compliant System
 (ISA) 0x00000127 (295)	Microsoft ACPI-Compliant System
 (ISA) 0x00000128 (296)	Microsoft ACPI-Compliant System
 (ISA) 0x00000129 (297)	Microsoft ACPI-Compliant System
 (ISA) 0x0000012A (298)	Microsoft ACPI-Compliant System



































	(ISA) 0x0000012B (299)	Microsoft ACPI-Compliant System
	(ISA) 0x0000012C (300)	Microsoft ACPI-Compliant System
	(ISA) 0x0000012D (301)	Microsoft ACPI-Compliant System
	(ISA) 0x0000012E (302)	Microsoft ACPI-Compliant System
	(ISA) 0x0000012F (303)	Microsoft ACPI-Compliant System
	(ISA) 0x00000130 (304)	Microsoft ACPI-Compliant System
	(ISA) 0x00000131 (305)	Microsoft ACPI-Compliant System
	(ISA) 0x00000132 (306)	Microsoft ACPI-Compliant System
	(ISA) 0x00000133 (307)	Microsoft ACPI-Compliant System
	(ISA) 0x00000134 (308)	Microsoft ACPI-Compliant System
	(ISA) 0x00000135 (309)	Microsoft ACPI-Compliant System
	(ISA) 0x00000136 (310)	Microsoft ACPI-Compliant System
	(ISA) 0x00000137 (311)	Microsoft ACPI-Compliant System
	(ISA) 0x00000138 (312)	Microsoft ACPI-Compliant System
	(ISA) 0x00000139 (313)	Microsoft ACPI-Compliant System
	(ISA) 0x0000013A (314)	Microsoft ACPI-Compliant System
	(ISA) 0x0000013B (315)	Microsoft ACPI-Compliant System
	(ISA) 0x0000013C (316)	Microsoft ACPI-Compliant System
	(ISA) 0x0000013D (317)	Microsoft ACPI-Compliant System
	(ISA) 0x0000013E (318)	Microsoft ACPI-Compliant System
	(ISA) 0x0000013F (319)	Microsoft ACPI-Compliant System
	(ISA) 0x00000140 (320)	Microsoft ACPI-Compliant System
	(ISA) 0x00000141 (321)	Microsoft ACPI-Compliant System
	(ISA) 0x00000142 (322)	Microsoft ACPI-Compliant System
	(ISA) 0x00000143 (323)	Microsoft ACPI-Compliant System
	(ISA) 0x00000144 (324)	Microsoft ACPI-Compliant System
	(ISA) 0x00000145 (325)	Microsoft ACPI-Compliant System
	(ISA) 0x00000146 (326)	Microsoft ACPI-Compliant System
	(ISA) 0x00000147 (327)	Microsoft ACPI-Compliant System
	(ISA) 0x00000148 (328)	Microsoft ACPI-Compliant System
	(ISA) 0x00000149 (329)	Microsoft ACPI-Compliant System
	(ISA) 0x0000014A (330)	Microsoft ACPI-Compliant System
	(ISA) 0x0000014B (331)	Microsoft ACPI-Compliant System



































	(ISA) 0x0000014C (332)	Microsoft ACPI-Compliant System
	(ISA) 0x0000014D (333)	Microsoft ACPI-Compliant System
	(ISA) 0x0000014E (334)	Microsoft ACPI-Compliant System
	(ISA) 0x0000014F (335)	Microsoft ACPI-Compliant System
	(ISA) 0x00000150 (336)	Microsoft ACPI-Compliant System
	(ISA) 0x00000151 (337)	Microsoft ACPI-Compliant System
	(ISA) 0x00000152 (338)	Microsoft ACPI-Compliant System
	(ISA) 0x00000153 (339)	Microsoft ACPI-Compliant System
	(ISA) 0x00000154 (340)	Microsoft ACPI-Compliant System
	(ISA) 0x00000155 (341)	Microsoft ACPI-Compliant System
	(ISA) 0x00000156 (342)	Microsoft ACPI-Compliant System
	(ISA) 0x00000157 (343)	Microsoft ACPI-Compliant System
	(ISA) 0x00000158 (344)	Microsoft ACPI-Compliant System
	(ISA) 0x00000159 (345)	Microsoft ACPI-Compliant System
	(ISA) 0x0000015A (346)	Microsoft ACPI-Compliant System
	(ISA) 0x0000015B (347)	Microsoft ACPI-Compliant System
	(ISA) 0x0000015C (348)	Microsoft ACPI-Compliant System
	(ISA) 0x0000015D (349)	Microsoft ACPI-Compliant System
	(ISA) 0x0000015E (350)	Microsoft ACPI-Compliant System
	(ISA) 0x0000015F (351)	Microsoft ACPI-Compliant System
	(ISA) 0x00000160 (352)	Microsoft ACPI-Compliant System
	(ISA) 0x00000161 (353)	Microsoft ACPI-Compliant System
	(ISA) 0x00000162 (354)	Microsoft ACPI-Compliant System
	(ISA) 0x00000163 (355)	Microsoft ACPI-Compliant System
	(ISA) 0x00000164 (356)	Microsoft ACPI-Compliant System
	(ISA) 0x00000165 (357)	Microsoft ACPI-Compliant System
	(ISA) 0x00000166 (358)	Microsoft ACPI-Compliant System
	(ISA) 0x00000167 (359)	Microsoft ACPI-Compliant System
	(ISA) 0x00000168 (360)	Microsoft ACPI-Compliant System
	(ISA) 0x00000169 (361)	Microsoft ACPI-Compliant System
	(ISA) 0x0000016A (362)	Microsoft ACPI-Compliant System
	(ISA) 0x0000016B (363)	Microsoft ACPI-Compliant System
	(ISA) 0x0000016C (364)	Microsoft ACPI-Compliant System



































	(ISA) 0x0000016D (365)	Microsoft ACPI-Compliant System
	(ISA) 0x0000016E (366)	Microsoft ACPI-Compliant System
	(ISA) 0x0000016F (367)	Microsoft ACPI-Compliant System
	(ISA) 0x00000170 (368)	Microsoft ACPI-Compliant System
	(ISA) 0x00000171 (369)	Microsoft ACPI-Compliant System
	(ISA) 0x00000172 (370)	Microsoft ACPI-Compliant System
	(ISA) 0x00000173 (371)	Microsoft ACPI-Compliant System
	(ISA) 0x00000174 (372)	Microsoft ACPI-Compliant System
	(ISA) 0x00000175 (373)	Microsoft ACPI-Compliant System
	(ISA) 0x00000176 (374)	Microsoft ACPI-Compliant System
	(ISA) 0x00000177 (375)	Microsoft ACPI-Compliant System
	(ISA) 0x00000178 (376)	Microsoft ACPI-Compliant System
	(ISA) 0x00000179 (377)	Microsoft ACPI-Compliant System
	(ISA) 0x0000017A (378)	Microsoft ACPI-Compliant System
	(ISA) 0x0000017B (379)	Microsoft ACPI-Compliant System
	(ISA) 0x0000017C (380)	Microsoft ACPI-Compliant System
	(ISA) 0x0000017D (381)	Microsoft ACPI-Compliant System
	(ISA) 0x0000017E (382)	Microsoft ACPI-Compliant System
	(ISA) 0x0000017F (383)	Microsoft ACPI-Compliant System
	(ISA) 0x00000180 (384)	Microsoft ACPI-Compliant System
	(ISA) 0x00000181 (385)	Microsoft ACPI-Compliant System
	(ISA) 0x00000182 (386)	Microsoft ACPI-Compliant System
	(ISA) 0x00000183 (387)	Microsoft ACPI-Compliant System
	(ISA) 0x00000184 (388)	Microsoft ACPI-Compliant System
	(ISA) 0x00000185 (389)	Microsoft ACPI-Compliant System
	(ISA) 0x00000186 (390)	Microsoft ACPI-Compliant System
	(ISA) 0x00000187 (391)	Microsoft ACPI-Compliant System
	(ISA) 0x00000188 (392)	Microsoft ACPI-Compliant System
	(ISA) 0x00000189 (393)	Microsoft ACPI-Compliant System
	(ISA) 0x0000018A (394)	Microsoft ACPI-Compliant System
	(ISA) 0x0000018B (395)	Microsoft ACPI-Compliant System
	(ISA) 0x0000018C (396)	Microsoft ACPI-Compliant System
	(ISA) 0x0000018D (397)	Microsoft ACPI-Compliant System



































	(ISA) 0x0000018E (398)	Microsoft ACPI-Compliant System
	(ISA) 0x0000018F (399)	Microsoft ACPI-Compliant System
	(ISA) 0x00000190 (400)	Microsoft ACPI-Compliant System
	(ISA) 0x00000191 (401)	Microsoft ACPI-Compliant System
	(ISA) 0x00000192 (402)	Microsoft ACPI-Compliant System
	(ISA) 0x00000193 (403)	Microsoft ACPI-Compliant System
	(ISA) 0x00000194 (404)	Microsoft ACPI-Compliant System
	(ISA) 0x00000195 (405)	Microsoft ACPI-Compliant System
	(ISA) 0x00000196 (406)	Microsoft ACPI-Compliant System
	(ISA) 0x00000197 (407)	Microsoft ACPI-Compliant System
	(ISA) 0x00000198 (408)	Microsoft ACPI-Compliant System
	(ISA) 0x00000199 (409)	Microsoft ACPI-Compliant System
	(ISA) 0x0000019A (410)	Microsoft ACPI-Compliant System
	(ISA) 0x0000019B (411)	Microsoft ACPI-Compliant System
	(ISA) 0x0000019C (412)	Microsoft ACPI-Compliant System
	(ISA) 0x0000019D (413)	Microsoft ACPI-Compliant System
	(ISA) 0x0000019E (414)	Microsoft ACPI-Compliant System
	(ISA) 0x0000019F (415)	Microsoft ACPI-Compliant System
	(ISA) 0x000001A0 (416)	Microsoft ACPI-Compliant System
	(ISA) 0x000001A1 (417)	Microsoft ACPI-Compliant System
	(ISA) 0x000001A2 (418)	Microsoft ACPI-Compliant System
	(ISA) 0x000001A3 (419)	Microsoft ACPI-Compliant System
	(ISA) 0x000001A4 (420)	Microsoft ACPI-Compliant System
	(ISA) 0x000001A5 (421)	Microsoft ACPI-Compliant System
	(ISA) 0x000001A6 (422)	Microsoft ACPI-Compliant System
	(ISA) 0x000001A7 (423)	Microsoft ACPI-Compliant System
	(ISA) 0x000001A8 (424)	Microsoft ACPI-Compliant System
	(ISA) 0x000001A9 (425)	Microsoft ACPI-Compliant System
	(ISA) 0x000001AA (426)	Microsoft ACPI-Compliant System
	(ISA) 0x000001AB (427)	Microsoft ACPI-Compliant System
	(ISA) 0x000001AC (428)	Microsoft ACPI-Compliant System
	(ISA) 0x000001AD (429)	Microsoft ACPI-Compliant System
	(ISA) 0x000001AE (430)	Microsoft ACPI-Compliant System





































































	(ISA) 0x000001AF (431)	Microsoft ACPI-Compliant System
	(ISA) 0x000001B0 (432)	Microsoft ACPI-Compliant System
	(ISA) 0x000001B1 (433)	Microsoft ACPI-Compliant System
	(ISA) 0x000001B2 (434)	Microsoft ACPI-Compliant System
	(ISA) 0x000001B3 (435)	Microsoft ACPI-Compliant System
	(ISA) 0x000001B4 (436)	Microsoft ACPI-Compliant System
	(ISA) 0x000001B5 (437)	Microsoft ACPI-Compliant System
	(ISA) 0x000001B6 (438)	Microsoft ACPI-Compliant System
	(ISA) 0x000001B7 (439)	Microsoft ACPI-Compliant System
	(ISA) 0x000001B8 (440)	Microsoft ACPI-Compliant System
	(ISA) 0x000001B9 (441)	Microsoft ACPI-Compliant System
	(ISA) 0x000001BA (442)	Microsoft ACPI-Compliant System
	(ISA) 0x000001BB (443)	Microsoft ACPI-Compliant System
	(ISA) 0x000001BC (444)	Microsoft ACPI-Compliant System
	(ISA) 0x000001BD (445)	Microsoft ACPI-Compliant System
	(ISA) 0x000001BE (446)	Microsoft ACPI-Compliant System
	(ISA) 0x000001BF (447)	Microsoft ACPI-Compliant System
	(ISA) 0x000001C0 (448)	Microsoft ACPI-Compliant System
	(ISA) 0x000001C1 (449)	Microsoft ACPI-Compliant System
	(ISA) 0x000001C2 (450)	Microsoft ACPI-Compliant System
	(ISA) 0x000001C3 (451)	Microsoft ACPI-Compliant System
	(ISA) 0x000001C4 (452)	Microsoft ACPI-Compliant System
	(ISA) 0x000001C5 (453)	Microsoft ACPI-Compliant System
	(ISA) 0x000001C6 (454)	Microsoft ACPI-Compliant System
	(ISA) 0x000001C7 (455)	Microsoft ACPI-Compliant System
	(ISA) 0x000001C8 (456)	Microsoft ACPI-Compliant System
	(ISA) 0x000001C9 (457)	Microsoft ACPI-Compliant System
	(ISA) 0x000001CA (458)	Microsoft ACPI-Compliant System
	(ISA) 0x000001CB (459)	Microsoft ACPI-Compliant System
	(ISA) 0x000001CC (460)	Microsoft ACPI-Compliant System
	(ISA) 0x000001CD (461)	Microsoft ACPI-Compliant System
	(ISA) 0x000001CE (462)	Microsoft ACPI-Compliant System
	(ISA) 0x000001CF (463)	Microsoft ACPI-Compliant System





































































	(ISA) 0x000001D0 (464)	Microsoft ACPI-Compliant System
	(ISA) 0x000001D1 (465)	Microsoft ACPI-Compliant System
	(ISA) 0x000001D2 (466)	Microsoft ACPI-Compliant System
	(ISA) 0x000001D3 (467)	Microsoft ACPI-Compliant System
	(ISA) 0x000001D4 (468)	Microsoft ACPI-Compliant System
	(ISA) 0x000001D5 (469)	Microsoft ACPI-Compliant System
	(ISA) 0x000001D6 (470)	Microsoft ACPI-Compliant System
	(ISA) 0x000001D7 (471)	Microsoft ACPI-Compliant System
	(ISA) 0x000001D8 (472)	Microsoft ACPI-Compliant System
	(ISA) 0x000001D9 (473)	Microsoft ACPI-Compliant System
	(ISA) 0x000001DA (474)	Microsoft ACPI-Compliant System
	(ISA) 0x000001DB (475)	Microsoft ACPI-Compliant System
	(ISA) 0x000001DC (476)	Microsoft ACPI-Compliant System
	(ISA) 0x000001DD (477)	Microsoft ACPI-Compliant System
	(ISA) 0x000001DE (478)	Microsoft ACPI-Compliant System
	(ISA) 0x000001DF (479)	Microsoft ACPI-Compliant System
	(ISA) 0x000001E0 (480)	Microsoft ACPI-Compliant System
	(ISA) 0x000001E1 (481)	Microsoft ACPI-Compliant System
	(ISA) 0x000001E2 (482)	Microsoft ACPI-Compliant System
	(ISA) 0x000001E3 (483)	Microsoft ACPI-Compliant System
	(ISA) 0x000001E4 (484)	Microsoft ACPI-Compliant System
	(ISA) 0x000001E5 (485)	Microsoft ACPI-Compliant System
	(ISA) 0x000001E6 (486)	Microsoft ACPI-Compliant System
	(ISA) 0x000001E7 (487)	Microsoft ACPI-Compliant System
	(ISA) 0x000001E8 (488)	Microsoft ACPI-Compliant System
	(ISA) 0x000001E9 (489)	Microsoft ACPI-Compliant System
	(ISA) 0x000001EA (490)	Microsoft ACPI-Compliant System
	(ISA) 0x000001EB (491)	Microsoft ACPI-Compliant System
	(ISA) 0x000001EC (492)	Microsoft ACPI-Compliant System
	(ISA) 0x000001ED (493)	Microsoft ACPI-Compliant System
	(ISA) 0x000001EE (494)	Microsoft ACPI-Compliant System
	(ISA) 0x000001EF (495)	Microsoft ACPI-Compliant System
	(ISA) 0x000001F0 (496)	Microsoft ACPI-Compliant System



































































	(ISA) 0x000001F1 (497)	Microsoft ACPI-Compliant System
	(ISA) 0x000001F2 (498)	Microsoft ACPI-Compliant System
	(ISA) 0x000001F3 (499)	Microsoft ACPI-Compliant System
	(ISA) 0x000001F4 (500)	Microsoft ACPI-Compliant System
	(ISA) 0x000001F5 (501)	Microsoft ACPI-Compliant System
	(ISA) 0x000001F6 (502)	Microsoft ACPI-Compliant System
	(ISA) 0x000001F7 (503)	Microsoft ACPI-Compliant System
	(ISA) 0x000001F8 (504)	Microsoft ACPI-Compliant System
	(ISA) 0x000001F9 (505)	Microsoft ACPI-Compliant System
	(ISA) 0x000001FA (506)	Microsoft ACPI-Compliant System
	(ISA) 0x000001FB (507)	Microsoft ACPI-Compliant System
	(ISA) 0x000001FC (508)	Microsoft ACPI-Compliant System
	(ISA) 0x000001FD (509)	Microsoft ACPI-Compliant System
	(ISA) 0x000001FE (510)	Microsoft ACPI-Compliant System
	(ISA) 0x000001FF (511)	Microsoft ACPI-Compliant System
	(PCI) 0x0000000A (10)	Intel(R) 8 Series/C220 Series Management Engine Interface - 8C3B
	(PCI) 0x0000000A (10)	Intel(R) Xeon(R) Processor D Family QuickData Technology Registers - 6F51
	(PCI) 0x0000000A (10)	Intel(R) Xeon(R) Processor D Family QuickData Technology Registers - 6F53
	(PCI) 0x0000000B (11)	Intel(R) 8 Series/C220 Series SMBus Controller - 8C22
	(PCI) 0x0000000B (11)	Intel(R) 8 Series/C220 Series Management Engine Interface - 8C3A
	(PCI) 0x0000000B (11)	Intel(R) Xeon(R) Processor D Family QuickData Technology Registers - 6F50
	(PCI) 0x0000000B (11)	Intel(R) Xeon(R) Processor D Family QuickData Technology Registers - 6F52
	(PCI) 0x00000010 (16)	Intel(R) 8 Series/C220 Series SATA AHCI Controller - 8C02
	(PCI) 0x00000012 (18)	Intel(R) 8 Series/C220 Series USB EHCI #1 - 8C26
	(PCI) 0x00000013 (19)	Standard Dual Channel PCI IDE Controller
	(PCI) 0xFFFFFFF64 (-156)	Intel(R) Ethernet Connection X552 10 GbE Backplane #2
	(PCI) 0xFFFFFFF65 (-155)	Intel(R) Ethernet Connection X552 10 GbE Backplane #2
	(PCI) 0xFFFFFFF66 (-154)	Intel(R) Ethernet Connection X552 10 GbE Backplane #2
	(PCI) 0xFFFFFFF67 (-153)	Intel(R) Ethernet Connection X552 10 GbE Backplane #2
	(PCI) 0xFFFFFFF68 (-152)	Intel(R) Ethernet Connection X552 10 GbE Backplane #2
	(PCI) 0xFFFFFFF69 (-151)	Intel(R) Ethernet Connection X552 10 GbE Backplane #2
	(PCI) 0xFFFFFFF6A (-150)	Intel(R) Ethernet Connection X552 10 GbE Backplane #2
	(PCI) 0xFFFFFFF6B (-149)	Intel(R) Ethernet Connection X552 10 GbE Backplane #2

 (PCI) 0xFFFFFFFF6C (-148)	Intel(R) Ethernet Connection X552 10 GbE Backplane #2
 (PCI) 0xFFFFFFFF6D (-147)	Intel(R) Ethernet Connection X552 10 GbE Backplane #2
 (PCI) 0xFFFFFFFF6E (-146)	Intel(R) Ethernet Connection X552 10 GbE Backplane #2
 (PCI) 0xFFFFFFFF6F (-145)	Intel(R) Ethernet Connection X552 10 GbE Backplane #2
 (PCI) 0xFFFFFFFF70 (-144)	Intel(R) Ethernet Connection X552 10 GbE Backplane #2
 (PCI) 0xFFFFFFFF71 (-143)	Intel(R) Ethernet Connection X552 10 GbE Backplane #2
 (PCI) 0xFFFFFFFF72 (-142)	Intel(R) Ethernet Connection X552 10 GbE Backplane #2
 (PCI) 0xFFFFFFFF73 (-141)	Intel(R) Ethernet Connection X552 10 GbE Backplane #2
 (PCI) 0xFFFFFFFF74 (-140)	Intel(R) Ethernet Connection X552 10 GbE Backplane #2
 (PCI) 0xFFFFFFFF75 (-139)	Intel(R) Ethernet Connection X552 10 GbE Backplane #2
 (PCI) 0xFFFFFFFF76 (-138)	Intel(R) Ethernet Connection X552 10 GbE Backplane
 (PCI) 0xFFFFFFFF77 (-137)	Intel(R) Ethernet Connection X552 10 GbE Backplane
 (PCI) 0xFFFFFFFF78 (-136)	Intel(R) Ethernet Connection X552 10 GbE Backplane
 (PCI) 0xFFFFFFFF79 (-135)	Intel(R) Ethernet Connection X552 10 GbE Backplane
 (PCI) 0xFFFFFFFF7A (-134)	Intel(R) Ethernet Connection X552 10 GbE Backplane
 (PCI) 0xFFFFFFFF7B (-133)	Intel(R) Ethernet Connection X552 10 GbE Backplane
 (PCI) 0xFFFFFFFF7C (-132)	Intel(R) Ethernet Connection X552 10 GbE Backplane
 (PCI) 0xFFFFFFFF7D (-131)	Intel(R) Ethernet Connection X552 10 GbE Backplane
 (PCI) 0xFFFFFFFF7E (-130)	Intel(R) Ethernet Connection X552 10 GbE Backplane
 (PCI) 0xFFFFFFFF7F (-129)	Intel(R) Ethernet Connection X552 10 GbE Backplane
 (PCI) 0xFFFFFFFF80 (-128)	Intel(R) Ethernet Connection X552 10 GbE Backplane
 (PCI) 0xFFFFFFFF81 (-127)	Intel(R) Ethernet Connection X552 10 GbE Backplane
 (PCI) 0xFFFFFFFF82 (-126)	Intel(R) Ethernet Connection X552 10 GbE Backplane
 (PCI) 0xFFFFFFFF83 (-125)	Intel(R) Ethernet Connection X552 10 GbE Backplane
 (PCI) 0xFFFFFFFF84 (-124)	Intel(R) Ethernet Connection X552 10 GbE Backplane
 (PCI) 0xFFFFFFFF85 (-123)	Intel(R) Ethernet Connection X552 10 GbE Backplane
 (PCI) 0xFFFFFFFF86 (-122)	Intel(R) Ethernet Connection X552 10 GbE Backplane
 (PCI) 0xFFFFFFFF87 (-121)	Intel(R) Ethernet Connection X552 10 GbE Backplane
 (PCI) 0xFFFFFFFF88 (-120)	Intel(R) Ethernet Converged Network Adapter X710 #4
 (PCI) 0xFFFFFFFF89 (-119)	Intel(R) Ethernet Converged Network Adapter X710 #4
 (PCI) 0xFFFFFFFF8A (-118)	Intel(R) Ethernet Converged Network Adapter X710 #4
 (PCI) 0xFFFFFFFF8B (-117)	Intel(R) Ethernet Converged Network Adapter X710 #4
 (PCI) 0xFFFFFFFF8C (-116)	Intel(R) Ethernet Converged Network Adapter X710 #4

	(PCI) 0xFFFFF8D (-115)	Intel(R) Ethernet Converged Network Adapter X710 #3
	(PCI) 0xFFFFF8E (-114)	Intel(R) Ethernet Converged Network Adapter X710 #3
	(PCI) 0xFFFFF8F (-113)	Intel(R) Ethernet Converged Network Adapter X710 #3
	(PCI) 0xFFFFF90 (-112)	Intel(R) Ethernet Converged Network Adapter X710 #3
	(PCI) 0xFFFFF91 (-111)	Intel(R) Ethernet Converged Network Adapter X710 #3
	(PCI) 0xFFFFF92 (-110)	Intel(R) Ethernet Converged Network Adapter X710 #2
	(PCI) 0xFFFFF93 (-109)	Intel(R) Ethernet Converged Network Adapter X710 #2
	(PCI) 0xFFFFF94 (-108)	Intel(R) Ethernet Converged Network Adapter X710 #2
	(PCI) 0xFFFFF95 (-107)	Intel(R) Ethernet Converged Network Adapter X710 #2
	(PCI) 0xFFFFF96 (-106)	Intel(R) Ethernet Converged Network Adapter X710 #2
	(PCI) 0xFFFFF97 (-105)	Intel(R) Ethernet Converged Network Adapter X710
	(PCI) 0xFFFFF98 (-104)	Intel(R) Ethernet Converged Network Adapter X710
	(PCI) 0xFFFFF99 (-103)	Intel(R) Ethernet Converged Network Adapter X710
	(PCI) 0xFFFFF9A (-102)	Intel(R) Ethernet Converged Network Adapter X710
	(PCI) 0xFFFFF9B (-101)	Intel(R) Ethernet Converged Network Adapter X710
	(PCI) 0xFFFFF9C (-100)	Intel(R) 82580 Gigabit Fiber Network Connection #4
	(PCI) 0xFFFFF9D (-99)	Intel(R) 82580 Gigabit Fiber Network Connection #4
	(PCI) 0xFFFFF9E (-98)	Intel(R) 82580 Gigabit Fiber Network Connection #4
	(PCI) 0xFFFFF9F (-97)	Intel(R) 82580 Gigabit Fiber Network Connection #4
	(PCI) 0xFFFFFA0 (-96)	Intel(R) 82580 Gigabit Fiber Network Connection #4
	(PCI) 0xFFFFFA1 (-95)	Intel(R) 82580 Gigabit Fiber Network Connection #4
	(PCI) 0xFFFFFA2 (-94)	Intel(R) 82580 Gigabit Fiber Network Connection #4
	(PCI) 0xFFFFFA3 (-93)	Intel(R) 82580 Gigabit Fiber Network Connection #4
	(PCI) 0xFFFFFA4 (-92)	Intel(R) 82580 Gigabit Fiber Network Connection #4
	(PCI) 0xFFFFFA5 (-91)	Intel(R) 82580 Gigabit Fiber Network Connection #4
	(PCI) 0xFFFFFA6 (-90)	Intel(R) 82580 Gigabit Fiber Network Connection #3
	(PCI) 0xFFFFFA7 (-89)	Intel(R) 82580 Gigabit Fiber Network Connection #3
	(PCI) 0xFFFFFA8 (-88)	Intel(R) 82580 Gigabit Fiber Network Connection #3
	(PCI) 0xFFFFFA9 (-87)	Intel(R) 82580 Gigabit Fiber Network Connection #3
	(PCI) 0xFFFFFAA (-86)	Intel(R) 82580 Gigabit Fiber Network Connection #3
	(PCI) 0xFFFFFAB (-85)	Intel(R) 82580 Gigabit Fiber Network Connection #3
	(PCI) 0xFFFFFAC (-84)	Intel(R) 82580 Gigabit Fiber Network Connection #3
	(PCI) 0xFFFFFAD (-83)	Intel(R) 82580 Gigabit Fiber Network Connection #3

	(PCI) 0xFFFFFAD (-83)	Intel(R) 82580 Gigabit Fiber Network Connection #3
	(PCI) 0xFFFFFAE (-82)	Intel(R) 82580 Gigabit Fiber Network Connection #3
	(PCI) 0xFFFFFAF (-81)	Intel(R) 82580 Gigabit Fiber Network Connection #3
	(PCI) 0xFFFFFB0 (-80)	Intel(R) 82580 Gigabit Fiber Network Connection #2
	(PCI) 0xFFFFFB1 (-79)	Intel(R) 82580 Gigabit Fiber Network Connection #2
	(PCI) 0xFFFFFB2 (-78)	Intel(R) 82580 Gigabit Fiber Network Connection #2
	(PCI) 0xFFFFFB3 (-77)	Intel(R) 82580 Gigabit Fiber Network Connection #2
	(PCI) 0xFFFFFB4 (-76)	Intel(R) 82580 Gigabit Fiber Network Connection #2
	(PCI) 0xFFFFFB5 (-75)	Intel(R) 82580 Gigabit Fiber Network Connection #2
	(PCI) 0xFFFFFB6 (-74)	Intel(R) 82580 Gigabit Fiber Network Connection #2
	(PCI) 0xFFFFFB7 (-73)	Intel(R) 82580 Gigabit Fiber Network Connection #2
	(PCI) 0xFFFFFB8 (-72)	Intel(R) 82580 Gigabit Fiber Network Connection #2
	(PCI) 0xFFFFFB9 (-71)	Intel(R) 82580 Gigabit Fiber Network Connection #2
	(PCI) 0xFFFFFBA (-70)	Intel(R) 82580 Gigabit Fiber Network Connection
	(PCI) 0xFFFFFBB (-69)	Intel(R) 82580 Gigabit Fiber Network Connection
	(PCI) 0xFFFFFBC (-68)	Intel(R) 82580 Gigabit Fiber Network Connection
	(PCI) 0xFFFFFBD (-67)	Intel(R) 82580 Gigabit Fiber Network Connection
	(PCI) 0xFFFFFBE (-66)	Intel(R) 82580 Gigabit Fiber Network Connection
	(PCI) 0xFFFFFBF (-65)	Intel(R) 82580 Gigabit Fiber Network Connection
	(PCI) 0xFFFFFC0 (-64)	Intel(R) 82580 Gigabit Fiber Network Connection
	(PCI) 0xFFFFFC1 (-63)	Intel(R) 82580 Gigabit Fiber Network Connection
	(PCI) 0xFFFFFC2 (-62)	Intel(R) 82580 Gigabit Fiber Network Connection
	(PCI) 0xFFFFFC3 (-61)	Intel(R) 82580 Gigabit Fiber Network Connection
	(PCI) 0xFFFFFC4 (-60)	Intel(R) 82580 Gigabit Fiber Network Connection #5
	(PCI) 0xFFFFFC5 (-59)	Intel(R) 82580 Gigabit Fiber Network Connection #5
	(PCI) 0xFFFFFC6 (-58)	Intel(R) 82580 Gigabit Fiber Network Connection #5
	(PCI) 0xFFFFFC7 (-57)	Intel(R) 82580 Gigabit Fiber Network Connection #5
	(PCI) 0xFFFFFC8 (-56)	Intel(R) 82580 Gigabit Fiber Network Connection #5
	(PCI) 0xFFFFFC9 (-55)	Intel(R) 82580 Gigabit Fiber Network Connection #5
	(PCI) 0xFFFFFCA (-54)	Intel(R) 82580 Gigabit Fiber Network Connection #5
	(PCI) 0xFFFFFCB (-53)	Intel(R) 82580 Gigabit Fiber Network Connection #5
	(PCI) 0xFFFFFCC (-52)	Intel(R) 82580 Gigabit Fiber Network Connection #5
	(PCI) 0xFFFFFCD (-51)	Intel(R) 82580 Gigabit Fiber Network Connection #5

	(PCI) 0xFFFFFCE (-50)	Intel(R) 82580 Gigabit Fiber Network Connection #6
	(PCI) 0xFFFFFCF (-49)	Intel(R) 82580 Gigabit Fiber Network Connection #6
	(PCI) 0xFFFFFD0 (-48)	Intel(R) 82580 Gigabit Fiber Network Connection #6
	(PCI) 0xFFFFFD1 (-47)	Intel(R) 82580 Gigabit Fiber Network Connection #6
	(PCI) 0xFFFFFD2 (-46)	Intel(R) 82580 Gigabit Fiber Network Connection #6
	(PCI) 0xFFFFFD3 (-45)	Intel(R) 82580 Gigabit Fiber Network Connection #6
	(PCI) 0xFFFFFD4 (-44)	Intel(R) 82580 Gigabit Fiber Network Connection #6
	(PCI) 0xFFFFFD5 (-43)	Intel(R) 82580 Gigabit Fiber Network Connection #6
	(PCI) 0xFFFFFD6 (-42)	Intel(R) 82580 Gigabit Fiber Network Connection #6
	(PCI) 0xFFFFFD7 (-41)	Intel(R) 82580 Gigabit Fiber Network Connection #6
	(PCI) 0xFFFFFD8 (-40)	Intel(R) 82580 Gigabit Fiber Network Connection #7
	(PCI) 0xFFFFFD9 (-39)	Intel(R) 82580 Gigabit Fiber Network Connection #7
	(PCI) 0xFFFFFDA (-38)	Intel(R) 82580 Gigabit Fiber Network Connection #7
	(PCI) 0xFFFFFDB (-37)	Intel(R) 82580 Gigabit Fiber Network Connection #7
	(PCI) 0xFFFFFDC (-36)	Intel(R) 82580 Gigabit Fiber Network Connection #7
	(PCI) 0xFFFFFDD (-35)	Intel(R) 82580 Gigabit Fiber Network Connection #7
	(PCI) 0xFFFFFDE (-34)	Intel(R) 82580 Gigabit Fiber Network Connection #7
	(PCI) 0xFFFFFDF (-33)	Intel(R) 82580 Gigabit Fiber Network Connection #7
	(PCI) 0xFFFFFE0 (-32)	Intel(R) 82580 Gigabit Fiber Network Connection #7
	(PCI) 0xFFFFFE1 (-31)	Intel(R) 82580 Gigabit Fiber Network Connection #7
	(PCI) 0xFFFFFE2 (-30)	Intel(R) 82580 Gigabit Fiber Network Connection #8
	(PCI) 0xFFFFFE3 (-29)	Intel(R) 82580 Gigabit Fiber Network Connection #8
	(PCI) 0xFFFFFE4 (-28)	Intel(R) 82580 Gigabit Fiber Network Connection #8
	(PCI) 0xFFFFFE5 (-27)	Intel(R) 82580 Gigabit Fiber Network Connection #8
	(PCI) 0xFFFFFE6 (-26)	Intel(R) 82580 Gigabit Fiber Network Connection #8
	(PCI) 0xFFFFFE7 (-25)	Intel(R) 82580 Gigabit Fiber Network Connection #8
	(PCI) 0xFFFFFE8 (-24)	Intel(R) 82580 Gigabit Fiber Network Connection #8
	(PCI) 0xFFFFFE9 (-23)	Intel(R) 82580 Gigabit Fiber Network Connection #8
	(PCI) 0xFFFFFEA (-22)	Intel(R) 82580 Gigabit Fiber Network Connection #8
	(PCI) 0xFFFFFEB (-21)	Intel(R) 82580 Gigabit Fiber Network Connection #8
	(PCI) 0xFFFFFEC (-20)	Intel(R) USB 3.0 eXtensible Host Controller - 0100 (Microsoft)
	(PCI) 0xFFFFFED (-19)	Intel(R) I211 Gigabit Network Connection
	(PCI) 0xFFFFFEE (-18)	Intel(R) I211 Gigabit Network Connection

	(PCI) 0xFFFFFDF (-33)	Intel(R) 82580 Gigabit Fiber Network Connection #7
	(PCI) 0xFFFFFE0 (-32)	Intel(R) 82580 Gigabit Fiber Network Connection #7
	(PCI) 0xFFFFFE1 (-31)	Intel(R) 82580 Gigabit Fiber Network Connection #7
	(PCI) 0xFFFFFE2 (-30)	Intel(R) 82580 Gigabit Fiber Network Connection #8
	(PCI) 0xFFFFFE3 (-29)	Intel(R) 82580 Gigabit Fiber Network Connection #8
	(PCI) 0xFFFFFE4 (-28)	Intel(R) 82580 Gigabit Fiber Network Connection #8
	(PCI) 0xFFFFFE5 (-27)	Intel(R) 82580 Gigabit Fiber Network Connection #8
	(PCI) 0xFFFFFE6 (-26)	Intel(R) 82580 Gigabit Fiber Network Connection #8
	(PCI) 0xFFFFFE7 (-25)	Intel(R) 82580 Gigabit Fiber Network Connection #8
	(PCI) 0xFFFFFE8 (-24)	Intel(R) 82580 Gigabit Fiber Network Connection #8
	(PCI) 0xFFFFFE9 (-23)	Intel(R) 82580 Gigabit Fiber Network Connection #8
	(PCI) 0xFFFFFEA (-22)	Intel(R) 82580 Gigabit Fiber Network Connection #8
	(PCI) 0xFFFFFEB (-21)	Intel(R) 82580 Gigabit Fiber Network Connection #8
	(PCI) 0xFFFFFEC (-20)	Intel(R) USB 3.0 eXtensible Host Controller - 0100 (Microsoft)
	(PCI) 0xFFFFFED (-19)	Intel(R) I211 Gigabit Network Connection
	(PCI) 0xFFFFFEE (-18)	Intel(R) I211 Gigabit Network Connection
	(PCI) 0xFFFFFEF (-17)	Intel(R) I211 Gigabit Network Connection
	(PCI) 0xFFFFFFF0 (-16)	Intel(R) I211 Gigabit Network Connection
	(PCI) 0xFFFFFFF1 (-15)	Intel(R) I211 Gigabit Network Connection
	(PCI) 0xFFFFFFF2 (-14)	Intel(R) I211 Gigabit Network Connection
	(PCI) 0xFFFFFFF3 (-13)	Intel(R) 8 Series/C220 Series PCI Express Root Port #8 - 8C1E
	(PCI) 0xFFFFFFF4 (-12)	Intel(R) 8 Series/C220 Series PCI Express Root Port #7 - 8C1C
	(PCI) 0xFFFFFFF5 (-11)	Intel(R) 8 Series/C220 Series PCI Express Root Port #5 - 8C18
	(PCI) 0xFFFFFFF6 (-10)	Intel(R) 8 Series/C220 Series PCI Express Root Port #1 - 8C10
	(PCI) 0xFFFFFFF7 (-9)	Intel(R) Xeon(R) Processor D Family PCI Express Root Port 3 - 6F0B
	(PCI) 0xFFFFFFF8 (-8)	Intel(R) Xeon(R) Processor D Family PCI Express Root Port 3 - 6F0A
	(PCI) 0xFFFFFFF9 (-7)	Intel(R) Xeon(R) Processor D Family PCI Express Root Port 3 - 6F08
	(PCI) 0xFFFFFFFA (-6)	Intel(R) Xeon(R) Processor D Family PCI Express Root Port 2 - 6F07
	(PCI) 0xFFFFFFFB (-5)	Intel(R) Xeon(R) Processor D Family PCI Express Root Port 2 - 6F06
	(PCI) 0xFFFFFFFC (-4)	Intel(R) Xeon(R) Processor D Family PCI Express Root Port 2 - 6F05
	(PCI) 0xFFFFFFFD (-3)	Intel(R) Xeon(R) Processor D Family PCI Express Root Port 2 - 6F04
	(PCI) 0xFFFFFFFE (-2)	Intel(R) Xeon(R) Processor D Family PCI Express Root Port 1 - 6F02

▶  Memory

Appendix C

Standard LAN Bypass Platform Setting

C.1 Status LED

The LED status indicator of FWS-7520 is programmable with AAEON SDK for your application.

Table1: LED Status

	STA_LED2	STA_LED1	STA_LED0
LED Off	0	0	0
Red LED On	0	0	1
Red LED Blink	0	1	0
Red LED Fast Blink	0	1	1
Reserved	1	0	0
Green LED Blink	1	0	1
Green LED Fast Blink	1	1	0
Green LED On	1	1	1

Table2: Status LED and register mapping table

CPLD Slave Address 0x90 (Note1)				
	Attribute	Offset(SMBUS)	BitNum	Value
STA_LED2	R/W	0x00 (Note2)	2	(Table 1)
STA_LED1	R/W	0x00 (Note2)	1	(Table 1)
STA_LED0	R/W	0x00 (Note2)	0	(Table 1)

Sample Code:

```

*****
#define ByteCPLD_SLAVE_ADDRESS //This parameter is represented from Note1
#define ByteOFFSET //This parameter is represented from Note2
*****
bData = aaeonSmbusReadByte(CPLD_SLAVE_ADDRESS, OFFSET);

switch( LED_FLAG)
{
case 0:
{
//LED Off
//BIT2=0, BIT1=0, BIT0=0
bData = bData & 0xF8;
break;
}
case 1:
{
//Red LED On
//BIT2=0, BIT1=0, BIT0=1
bData = (bData & 0xF8) | 0x01;
break;
}
case 2:
{
//Red LED Blink
//BIT2=0, BIT1=1, BIT0=0
bData = (bData & 0xF8) | 0x02;
break;
}
case 3:
{
//Red LED Fast Blink
//BIT2=0, BIT1=1, BIT0=1
bData = (bData & 0xF8) | 0x03;
break;
}
case 4:
{
//Green LED On
//BIT2=1, BIT1=1, BIT0=1

```

```
        bData = (bData & 0xF8) | 0x07;
        break;
    }
    case 5:
    {
        //Green LED Blink
        //BIT2=1, BIT1=0, BIT0=1
        bData = (bData & 0xF8) | 0x05;
        break;
    }
    case 6:
    {
        //Green LED Fast Blink
        //BIT2=1, BIT1=1, BIT0=0
        bData = (bData & 0xF8) | 0x06;
        break;
    }
    default:
        break;
}
SmbusWriteByte(CPLD_SLAVE_ADDRESS, 0x00, bData);
*****
```

C.2 LAN Bypass

Table1: LAN Kit ID Select

LAN_ID2	LAN_ID1	LAN_ID0	LAN kit selected
0	0	0	LAN Kit 1 Selected
0	0	1	LAN Kit 2 Selected
0	1	0	LAN Kit 3 Selected
0	1	1	LAN Kit 4 Selected
1	0	0	LAN Kit 5 Selected
1	0	1	LAN Kit 6 Selected

Table2: LAN Bypass register table

Function	Description
LAN_ID3	Use for selecting which LAN kit will be configured, refer to Table 1 of ID Select table of LAN kit. They should be set before ACT_EN.
LAN_ID2	
LAN_ID1	
LAN_ID0	
PWR_ON	Use for configuring LAN Bypass function behavior to LAN kit, when system power on. 1: Bypass 0: Pass Through
PWR_OFF	Use for configuring LAN Bypass function behavior to LAN kit, when system power off. 1: Bypass 0: Pass Through
WDT_EN	Use for configuring WDT function behavior to LAN kit, when WDT triggered. 0: Normal WDT reset (Default) 1: Force Bypass
ACT_EN	Use for activating programming of LAN kit. It is edge triggering (falling edge 1 to 0) and should be set to high(1) as its normal state.

Table3: LAN Bypass register mapping table

CPLD Slave Address 0x90 (Note1)				
	Attribute	Offset(SMBUS)	BitNum	Value
LAN_ID3	R/W	0x01(Note2)	3	(Table 1)
LAN_ID2	R/W	0x01(Note2)	2	(Table 1)
LAN_ID1	R/W	0x01(Note2)	1	(Table 1)
LAN_ID0	R/W	0x01(Note2)	0	(Table 1)
PWR_ON	R/W	0x01(Note2)	6	(Table 2)
PWR_OFF	R/W	0x01(Note2)	5	(Table 2)
WDT_EN	R/W	0x01(Note2)	4	(Table 2)
ACT_EN	R/W	0x01(Note2)	7	(Table 2)

Sample Code

```

*****
#define ByteCPLD_SLAVE_ADDRESS //This parameter is represented from Note1
#define ByteOFFSET //This parameter is represented from Note2
*****

// Select Lan Pair
BYTE bLanSel = LAN_PAIR;

BYTE bData = SmbusReadByte(CPLD_SLAVE_ADDRESS, OFFSET);
// Set Reg01h bit3
if(bLanSel & 0x08)
    bData = bData | 0x08;
else
    bData = bData & 0xF7;
// Set Reg01h bit2
if(bLanSel & 0x04)
    bData = bData | 0x04;
else
    bData = bData & 0xFB;
// Set Reg01h bit1
if(bLanSel & 0x02)
    bData = bData | 0x02;
else
    bData = bData & 0xFD;

```

```
// Set Reg01h bit0
if(bLanSel & 0x01)
    bData = bData | 0x01;
else
    bData = bData & 0xFE;

// Power On Action (Reg01h bit6)
if(SET_PASS_THROUGH) // Pass Through
    bData = bData & 0xBF;
else // Bypass
    bData = bData | 0x40;

// Power Off Action (Reg01h bit5)
if(SET_PASS_THROUGH) // Pass Through
    bData = bData & 0xDF;
else // Bypass
    bData = bData | 0x20;

// WDT Action (Reg01h bit4)
if(SET_WDT_RESET)// Reset
    bData = bData & 0xEF;
else // Bypass
    bData = bData | 0x10;

SmbusWriteByte(CPLD_SLAVE_ADDRESS, OFFSET, bData);

// Apply Settings (Reg01h bit7)
bData = SmbusReadByte(CPLD_SLAVE_ADDRESS, OFFSET);
SmbusWriteByte(CPLD_SLAVE_ADDRESS, OFFSET, bData & 0x7F);
Sleep(500);
bData = SmbusReadByte(CPLD_SLAVE_ADDRESS, OFFSET);
SmbusWriteByte(CPLD_SLAVE_ADDRESS, OFFSET, bData | 0x80);
*****
```

C.3 Software Reset Button (General Propose Input)

Table 1: Soft Reset Button register mapping table

	Attribute	Register(I/O)	BitNum	Value
BTN_STS	R	0xA05(Note1)	4(Note2)	(Note3)

Table 2: LAN Bypass register table

Function	Description
BTN_STS	Reading this register returns the pin level status which is normal high active low. 0: Pin Level States Low. 1: Pin Level States High.

Sample Code:

```
*****
#define Word    BTN_STS    //This parameter is represented from Note1
#define ByteBTN_STS_R    //This parameter is represented from Note2
*****
Byte  GET_Value (Word IoAddr, Byte BitNum,Byte Value){
    BYTE  TmpValue;

    TmpValue = inportb (IoAddr);
    return  (TmpValue & (1 << BitNum))
}
*****
VOID  Main(){
    Byte RstBtn;

    RstBtn = GET_Value (BTN_STS, BTN_STS_R); // Active Low
}
*****
```