



EPIC-BTS9

EPIC Board

User's Manual 1st Ed

Copyright Notice

This document is copyrighted, 2026. All rights are reserved. The original manufacturer reserves the right to make improvements to the products described in this manual at any time without notice.

No part of this manual may be reproduced, copied, translated, or transmitted in any form or by any means without the prior written permission of the original manufacturer. Information provided in this manual is intended to be accurate and reliable. However, the original manufacturer assumes no responsibility for its use, or for any infringements upon the rights of third parties that may result from its use.

The material in this document is for product information only and is subject to change without notice. While reasonable efforts have been made in the preparation of this document to assure its accuracy, AAEON assumes no liabilities resulting from errors or omissions in this document, or from the use of the information contained herein.

AAEON reserves the right to make changes in the product design without notice to its users.

Acknowledgement

All other products' name or trademarks are properties of their respective owners.

- Microsoft Windows is a registered trademark of Microsoft Corp.
- Intel® is a registered trademark of Intel Corporation
- Core™ is a trademark of Intel Corporation
- IBM, PC/AT, PS/2, and VGA are trademarks of International Business Machines Corporation.
- Linux® is the registered trademark of Linus Torvalds in the U.S. and other countries.
- Realtek is a trademark of Realtek Semiconductor Corporation.
- Ubuntu is a trademark of Canonical.

All other product names or trademarks are properties of their respective owners. No ownership is implied or assumed for products, names or trademarks not herein listed by the publisher of this document.

Packing List

Before setting up your product, please make sure the following items have been shipped:

Item	Quantity
● EPIC-BTS9	1
● CPU Cooler Back Plate	2
● Screw Kit	1

If any of these items are missing or damaged, please contact your distributor or sales representative immediately.

About this Document

This User's Manual contains all the essential information, such as detailed descriptions and explanations on the product's hardware and software features (if any), its specifications, dimensions, jumper/connector settings/definitions, and driver installation instructions (if any), to facilitate users in setting up their product.

Users may refer to the product page on AAEON.com for the latest version of this document.

Safety Precautions

Please read the following safety instructions carefully. It is advised that you keep this manual for future references

1. All cautions and warnings on the device should be noted.
2. Make sure the power source matches the power rating of the device.
3. Position the power cord so that people cannot step on it. Do not place anything over the power cord.
4. Always completely disconnect the power before working on the system's hardware.
5. No connections should be made when the system is powered as a sudden rush of power may damage sensitive electronic components.
6. If the device is not to be used for a long time, disconnect it from the power supply to avoid damage by transient over-voltage.
7. Always disconnect this device from any AC supply before cleaning.
8. While cleaning, use a damp cloth instead of liquid or spray detergents.
9. Make sure the device is installed near a power outlet and is easily accessible.
10. Keep this device away from humidity.
11. Place the device on a solid surface during installation to prevent falls
12. Do not cover the openings on the device to ensure optimal heat dissipation.
13. Watch out for high temperatures when the system is running.
14. Do not touch the heat sink or heat spreader when the system is running
15. Never pour any liquid into the openings. This could cause fire or electric shock.
16. As most electronic components are sensitive to static electrical charge, be sure to ground yourself to prevent static charge when installing the internal components. Use a grounding wrist strap and contain all electronic components in any static-shielded containers.

17. If any of the following situations arises, please the contact our service personnel:
 - i. Damaged power cord or plug
 - ii. Liquid intrusion to the device
 - iii. Exposure to moisture
 - iv. Device is not working as expected or in a manner as described in this manual
 - v. The device is dropped or damaged
 - vi. Any obvious signs of damage displayed on the device
18. **DO NOT LEAVE THIS DEVICE IN AN UNCONTROLLED ENVIRONMENT WITH TEMPERATURES BEYOND THE DEVICE'S PERMITTED STORAGE TEMPERATURES (SEE CHAPTER 1) TO PREVENT DAMAGE.**

Warning!



This device complies with Part 15 FCC Rules. Operation is subject to the following two conditions: (1) this device may not cause harmful interference, and (2) this device must accept any interference received including interference that may cause undesired operation.

Caution:

There is a danger of explosion if the battery is incorrectly replaced. Replace only with the same or equivalent type recommended by the manufacturer. Dispose of used batteries according to the manufacturer's instructions and your local government's recycling or disposal directives.

Attention:

Il y a un risque d'explosion si la batterie est remplacée de façon incorrecte. Ne la remplacer qu'avec le même modèle ou équivalent recommandé par le constructeur. Recycler les batteries usées en accord avec les instructions du fabricant et les directives gouvernementales de recyclage.

产品中有毒有害物质或元素名称及含量

AAEON 主板/子板/背板

QO4-381 Rev.A2

部件名称	有毒有害物质或元素					
	铅 (Pb)	汞 (Hg)	镉 (Cd)	六价铬 (Cr(VI))	多溴联苯 (PBB)	多溴二苯醚 (PBDE)
印刷电路板 及其电子组件	×	○	○	○	○	○
外部信号 连接器及线材	×	○	○	○	○	○

本表格依据 SJ/T 11364 的规定编制。

○：表示该有毒有害物质在该部件所有均质材料中的含量均在GB/T 26572标准规定的限量要求以下。

×：表示该有害物质的某一均质材料超出了GB/T 26572的限量要求，然而该部件仍符合欧盟指令2011/65/EU 的规范。

环保使用期限(EFUP (Environmental Friendly Use Period))：10年

备注：此产品所标示之环保使用期限，系指在一般正常使用状况下。

China RoHS Requirement (EN)

Name and content of hazardous substances in product

AAEON Main Board/Daughter Board/Backplane

QQ4-381 Rev.A2

Part Name	Hazardous Substances					
	铅 (Pb)	汞 (Hg)	镉 (Cd)	六价铬 (Cr(VI))	多溴联苯 (PBB)	多溴二苯醚 (PBDE)
PCB Assemblies	×	○	○	○	○	○
Connector and Cable	×	○	○	○	○	○

The table is prepared in accordance with the provisions of SJ/T 11364.

○: Indicates that said hazardous substance contained in all of the homogenous materials for this product is below the limit requirement of GB/T 26572.

×: Indicates that said hazardous substance contained in at least one of the homogenous materials used for this part is above the limit requirement of GB/T 26572. But this product still be compliance with 2011/65/EU Directive (allowed with 2011/65/EU Annex III of RoHS exemption with number 6(c),7(a),7(c)-1).

EFUP (Environment Friendly Use Period) value: 10 years

Notes: This product defined period of use is under normal condition.

Table of Contents

Chapter 1 - Product Specifications	1
1.1 Specifications.....	2
1.2 Block Diagram.....	6
Chapter 2 – Hardware Information	7
2.1 Dimensions	8
2.2 Jumpers and Connectors.....	10
2.3 List of Jumpers	12
2.3.1 Clear CMOS Jumper (JP1)	12
2.3.2 Auto Power Button AT/ATX Selection (JP2)	13
2.3.3 COM 2 Pin 8 Function Selection (JP4).....	14
2.4 List of Connectors	15
2.4.1 RTC Battery Connector (CN1)	17
2.4.2 SATA Connector (CN2/CN3).....	17
2.4.3 Audio I/O Port (CN5).....	18
2.4.4 +5V Output for SATA HDD (CN6).....	19
2.4.5 External +5VSB Input (CN7)	19
2.4.6 PCIe [x8] Slot (CN9).....	20
2.4.7 USB 2.0 Connector (CN13).....	20
2.4.8 COM 1/2 Connector (RS-232/422/485) (CN14)	21
2.4.9 GPIO Port (CN20).....	22
2.4.10 LAN 3 LED (CN21)	23
2.4.11 SPI BIOS Debug Port (CN27)	23
2.4.12 M.2 2230 E-Key (CN28).....	24
2.4.13 Nano SIM Card Socket (CN29).....	24
2.4.14 M.2 3042/3052 B-Key (CN30).....	25

2.4.15	PCIe [x2] FPC Connector (CN31).....	25
2.4.16	M.2 2280 M-Key (CN32).....	27
2.4.17	Time Sync (TCC) (CN33).....	27
2.4.18	+5V Output for SATA HDD (CN34).....	28
2.4.19	CPU Fan (CN35).....	28
2.4.20	Vcore Programming Connector (CN39).....	29
2.4.21	6-Pin DC in ATX Connector (CN42).....	29
2.4.22	RJ-45 LAN Port I226 +USB 3.2 (CN45).....	30
2.4.23	RJ-45 LAN Port I219 + USB 3.2 (CN46).....	31
2.4.24	Dual 2.5GbE LAN (LAN 3: Left, LAN 4: Right) (CN48).....	32
2.4.25	LAN 4 LED (CN51).....	33
2.4.26	Front Panel (CN52).....	33
2.4.27	HDMI Connector (CN54).....	34
2.4.28	SMBus/I2C (CN55).....	35
2.4.29	eSPI Connector for Debug (CN56).....	35
2.4.30	eDP Connector. (CN57).....	36
2.4.31	DDR5 SODIMM Slot (DIMM1).....	37
2.4.32	DDR5 SODIMM Slot (DIMM2).....	38
2.5	CPU Cooler Installation.....	39
Chapter 3 - AMI BIOS Setup.....		41
3.1	System Test and Initialization.....	42
3.2	AMI BIOS Setup.....	43
3.3	Setup Submenu: Main.....	44
3.4	Setup Submenu: Advanced.....	45
3.4.1	CPU Configuration.....	46
3.4.2	PCH-FW Configuration.....	47
3.4.3	Firmware Update Configuration.....	48

3.4.4	PTT Configuration	49
3.4.5	Trusted Computing.....	50
3.4.6	SATA Configuration	52
3.4.7	Hardware Monitor	53
3.4.7.1	Smart Fan Mode Configuration	54
3.4.8	SIO Configuration.....	55
3.4.8.1	Serial Port 1 Configuration.....	56
3.4.8.2	Serial Port 2 Configuration.....	57
3.4.9	Serial Port Console Redirection	58
3.4.10	Legacy Console Redirection Settings	59
3.4.11	AAEON BIOS Robot.....	60
3.4.12	Power Management.....	62
3.4.13	GPIO Port Configuration.....	63
3.4.14	AAEON Smart Boost.....	64
3.5	Setup Submenu: Chipset	65
3.5.1	System Agent (SA) Configuration	66
3.5.2	Memory Configuration.....	67
3.5.3	VMD Setup Menu.....	68
3.5.4	PCH-IO Configuration	69
3.6	Setup Submenu: Security.....	70
3.6.1	Secure Boot.....	71
3.6.2	Key Management	72
3.7	Setup Submenu: Boot	74
3.8	Setup Submenu: Save & Exit.....	75
3.9	Setup Submenu: MEBx.....	76
3.9.1	Intel® AMT Configuration.....	77
3.9.2	Redirection Features	78

3.9.3	User Consent	79
3.9.4	Power Control.....	80
Chapter 4	– Drivers Installation.....	81
4.1	Drivers Download and Installation.....	82
Appendix A	– I/O Information	86
A.1	I/O Address Map	87
A.2	Memory Address Map	89
A.3	Large Memory Address	90
A.4	IRQ Mapping Chart.....	91
Appendix B	– Mating Connectors	94
B.1	List of Mating Connectors and Cables.....	95
Appendix C	– 3-Pin ATX Behavior Description	96
C.1	3-Pin ATX Behavior Description	97
C.2	ATX Power Table	100

Chapter 1

Product Specifications

1.1 Specifications

System

Form Factor	4" EPIC Board
CPU	Intel® Core™ processors (Series 2) (up to 35W/65W) Intel® Core™ Processors (14th Gen) (up to 35W/65W) 13th Generation Intel® Core™ Processor (up to 35W/65W) 12th Generation Intel® Core™ Processor (up to 35W/65W)
Chipset	Intel® 600 Series Chipset Family (R680E/Q670E/H610E)
Memory Type	DDR5 4800, Dual Channel SODIMM x 2, up to 64GB (ECC support only for Intel® R680E Chipset SKU)
BIOS	UEFI
Wake on LAN	Yes
Watchdog Timer	255 Levels
Security	TPM 2.0
RTC Battery	Lithium Battery 3V/240mAh
Dimension	4.53" x 6.50" (115mm x 165mm)
OS Support	Windows® 10/11 (64-bit) Ubuntu 24.04.2/Kernel 6.14.0-27-generic x86_64

Power

Power Requirement	+12V, support ERP (Note: To achieve stable performance, using the power supply unit rated 22A @12V DC output, to meet the potential maximum peak requirement is recommended)
Power Supply Type	AT/ATX
Connector	6-Pin ATX Connector

Power

Power Consumption	Intel® Core™ 7 Processor 251E, DDR5 32GB x 2, 8.25A @+12V (Typical)
	Intel® Core™ 7 Processor 251E, DDR5 32GB x 2, 24.76A @+12V (Max)

Display

Controller	Intel® UHD Graphics 770 (i5 SKU and above) Intel® UHD Graphics 730 (i3 SKU) Intel® UHD Graphics 710
LVDS/eDP	eDP 1.4 x 1, up to 3840 x 2160 @60Hz
Display Interface	HDMI 2.0 x 1, up to 3840 x 2160 @60Hz VGA x 1, up to 1920 x 1080
Multiple Display	Up to 3 Simultaneous Displays

Audio

Codec	Realtek ALC897
Audio Interface	Line-In/Line-Out/Mic
Speaker	-

External I/O

Ethernet	Intel® Ethernet Controller I226, 2.5GbE RJ-45 x 3 Intel® Ethernet Connection I219, GbE RJ-45 x 1
USB	USB 3.2 Gen 1 x 1 USB 3.2 Gen 2 x 1
Serial Port	-
Video	HDMI 2.0 x 1, up to 3840 x 2160 @60Hz

Internal I/O

USB	USB 2.0 x 2
Serial Port	COM 1 (RS-232/422/485, support RI only) COM 2 (RS-232/422/485, support 12V/5V/RI)
Video	eDP 1.4 x 1, up to 3840 x 2160 @60Hz VGA x 1, up to 1920 x 1080
SATA	SATA 6Gb/s x 2 +5V SATA Power Connector x 2
Audio	Realtek ALC897
DIO/GPIO	GPIO 8-bit
SMBus/I2C	SMBus/I2C (change by BOM, I2C only for Windows 10)
Touch	-
Fan	4-Pin Smart Fan
SIM	Nano SIM x 1
Front Panel	Power Button, Reset Button, Power LED, SATA LED, Buzzer
Others	TCC x 1 (R680E SKU only)

Expansion

Mini PCIe/mSATA	-
M.2	M.2 2280 M-Key x 1 (PCIe 4.0 [x4], R680E & Q670E SKU support) M.2 3052 B-Key x 1 (PCIe 3.0 [x1] + USB 3.0) M.2 2230 E-Key x 1 (PCIe 3.0 [x1] + USB 2.0)
Others	PCIe 4.0 [x8] Slot x 1 (Supplies maximum 25W to the PCIe peripheral) FPC Connector x 1 (PCIe 3.0 [x2])

Environmental

Operating Temperature	32°F – 140°F (0°C – 60°C) (Note: To achieve the best performance, keeping the EPIC-BTS9 operating with 0.5m/sec airflow when DDR5 SODIMM 1 installed on bottom side is recommended)
Storage Temperature	-40°F – 185°F (-40°C – 85°C)
Operating Humidity	0% – 90% relative humidity, non-condensing
MTBF (Hours)	353,666
EMC	CE/FCC Class A

1.2 Block Diagram

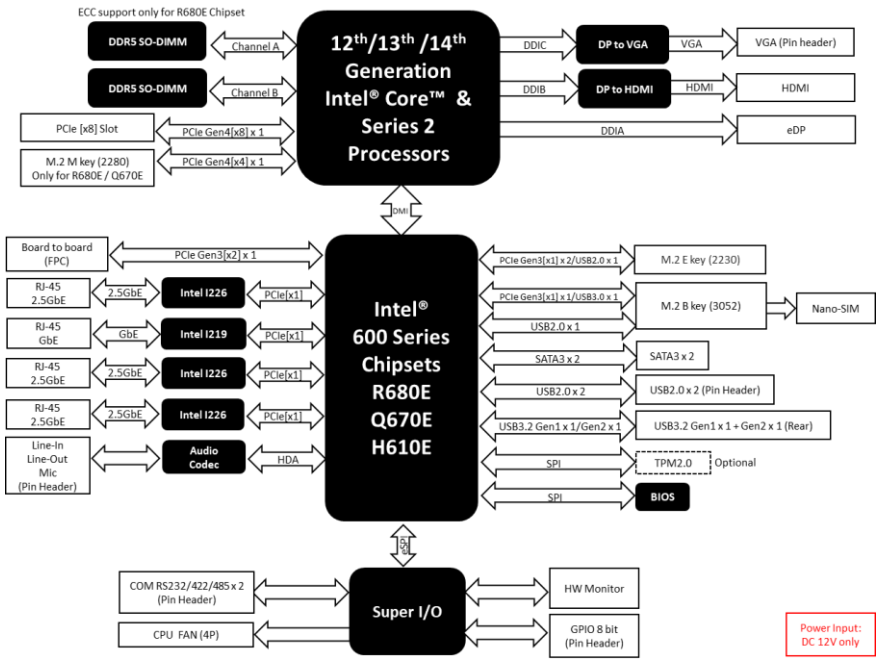

* Please note that the exact functions may differ based on PCH SKU.

Chapter 2

Hardware Information

2.1 Dimensions

Top View

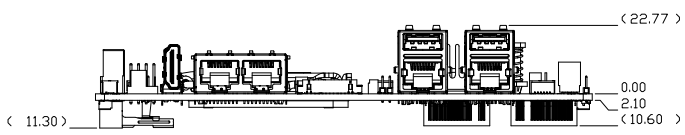
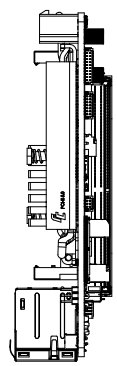
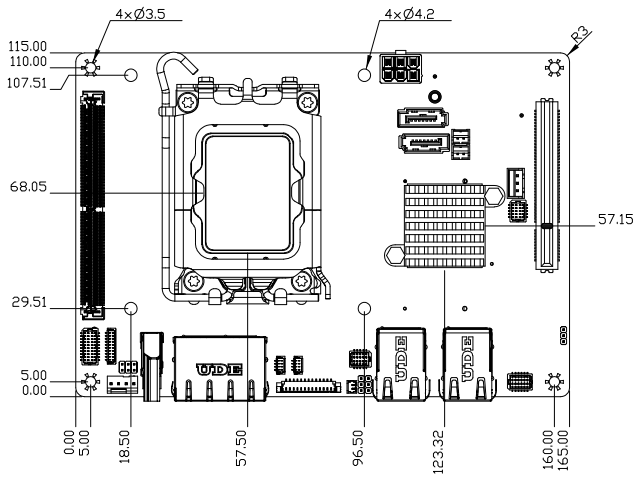

With Fan

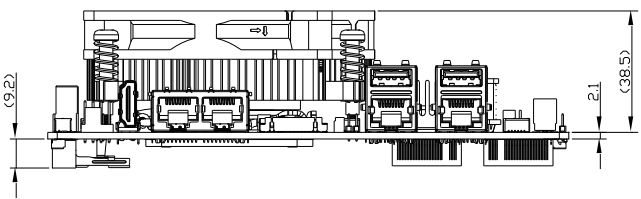

Bottom View

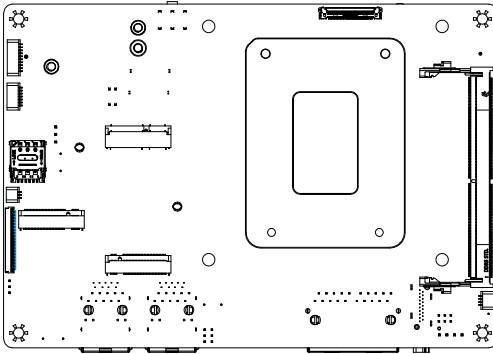

2.2 Jumpers and Connectors

Top View

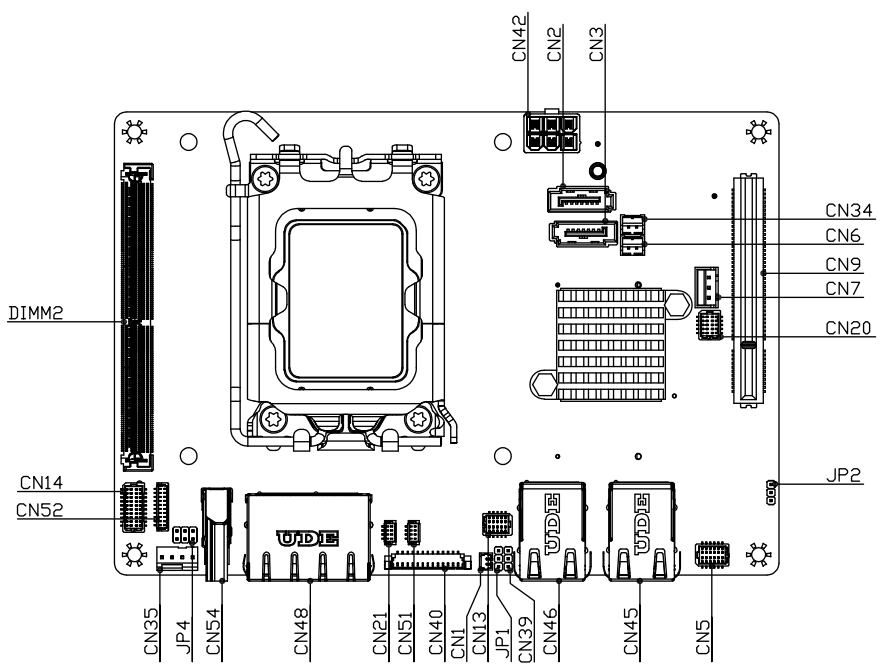

Bottom View

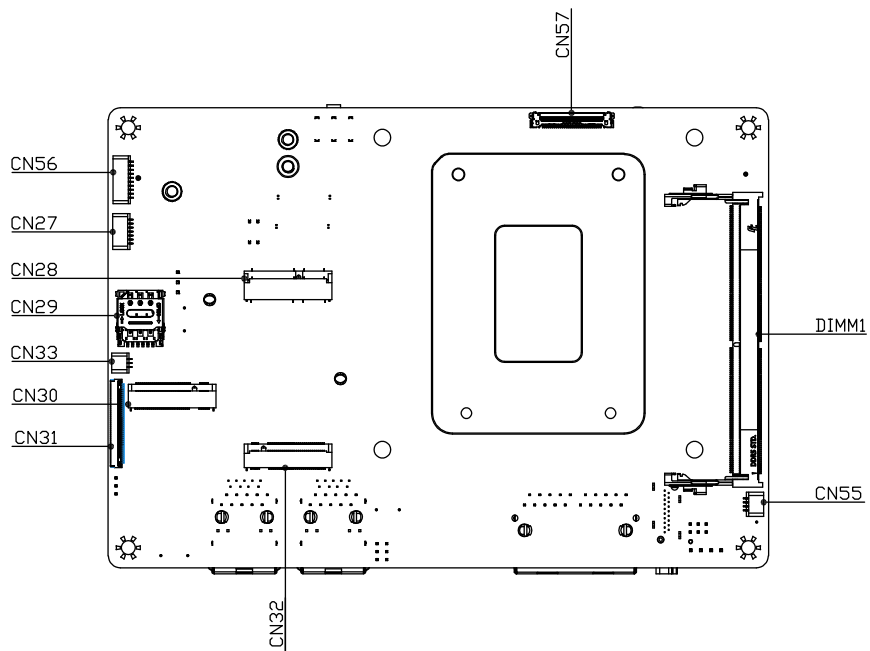

2.3 List of Jumpers

The board features a number of jumpers which can be configured for your application. Please refer to the table below and following sections for all jumpers which can be configured.

Label	Function
JP1	Clear CMOS Jumper
JP2	Auto Power Button AT/ATX Selection
JP4	COM 2 Pin 8 Function Selection

2.3.1 Clear CMOS Jumper (JP1)

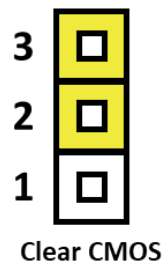
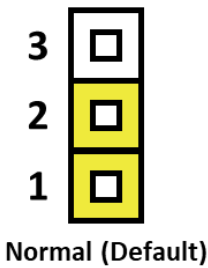
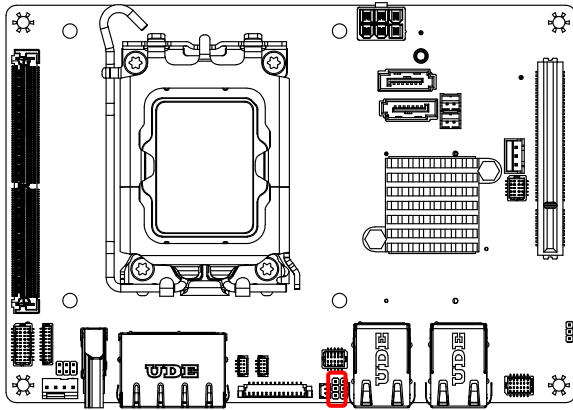

2.3.2 Auto Power Button AT/ATX Selection (JP2)

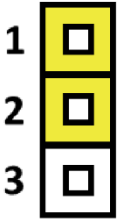
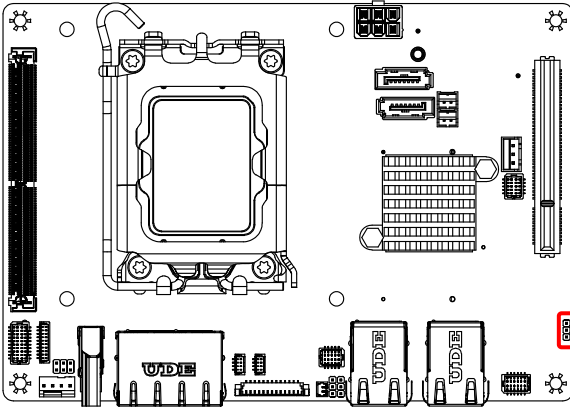

ATX



AT (Default)

2.3.3 COM 2 Pin 8 Function Selection (JP4)

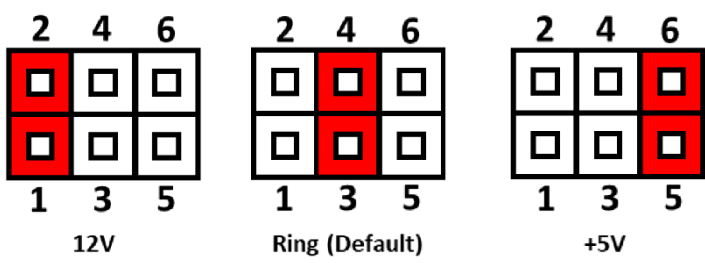
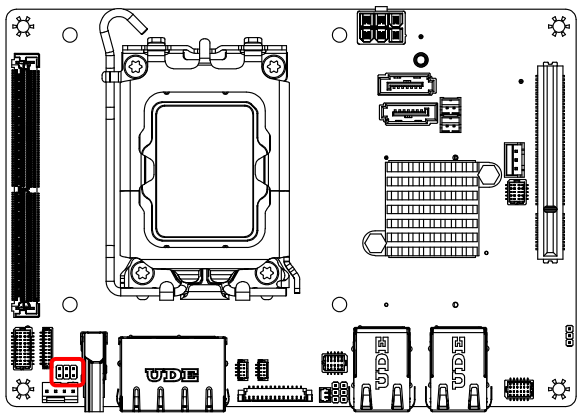

2.4 List of Connectors

This section details the connectors featured on the board, which can be configured for your application. For a list of mating connectors and cables, please see Appendix C. For Electrical Specifications of I/O Ports, please see Appendix D.

Please refer to the table below for a list of all connectors on this board which can be configured.

Label	Function
CN1	RTC Battery Connector
CN2	SATA Connector
CN3	SATA Connector
CN5	Audio I/O Port
CN6	SATA Power Connector
CN7	External +5VSB Input
CN9	PCIe [x8] Slot
CN13	USB 2.0 Connector
CN14	COM 1/2 Connector (RS-232/422/485)
CN20	GPIO
CN21	LAN LED
CN27	SPI BIOS Debug Port
CN28	M.2 2230 E-Key
CN29	Nano SIM Card Socket
CN30	M.2 3042/3052 B-Key
CN31	PCIe [x2] FPC Connector
CN32	M.2 2280 M-Key
CN33	Time Sync (TCC)
CN34	SATA Power Connector
CN35	CPU Fan Connector
CN39	Vcore Programming Connector
CN40	VGA Connector.
CN42	6-Pin DC in ATX Connector
CN45	RJ-45 LAN Port I226 +USB 3.2
CN46	RJ-45 LAN Port I219 + USB 3.2
CN48	Dual 2.5GbE LAN
CN51	LAN LED
CN52	Front Panel
CN54	HDMI Connector

Label	Function
CN55	SMBus/I2C
CN56	eSPI Connector for Debug
CN57	eDP Connector
DIMM1	DDR5 SODIMM Slot 1
DIMM2	DDR5 SODIMM Slot 2

2.4.1 RTC Battery Connector (CN1)

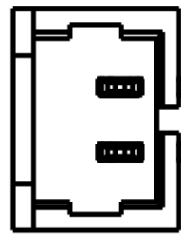
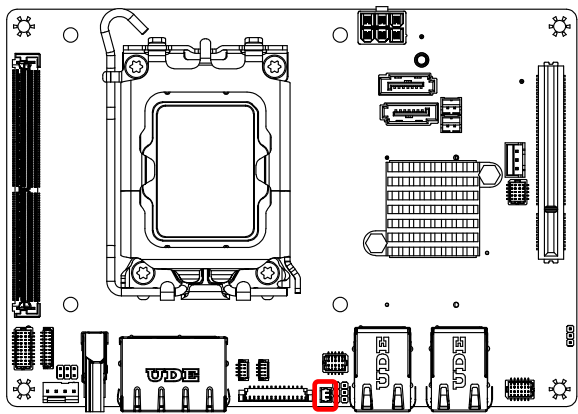

Pin	Pin Name	Signal Type	Signal Level
1	+3.3V	PWR	3.3V
2	GND	GND	

2.4.2 SATA Connector (CN2/CN3)

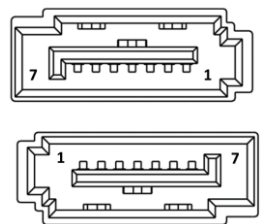
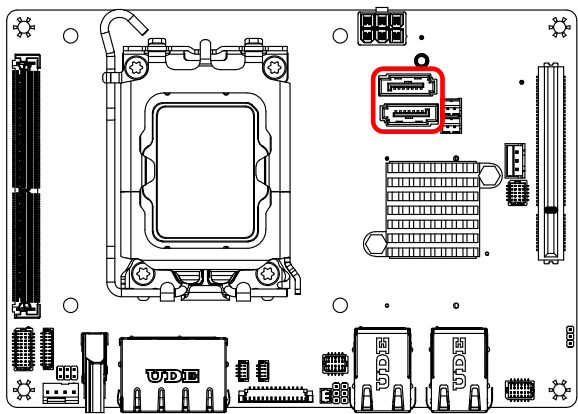

Pin	Pin Name	Signal Type	Signal Level
1	GND	GND	
2	SATA_TX+	DIFF	
3	SATA_TX-	DIFF	
4	GND	GND	
5	SATA_RX-	DIFF	

Pin	Pin Name	Signal Type	Signal Level
6	SATA_RX+	DIFF	
7	GND	GND	

2.4.3 Audio I/O Port (CN5)

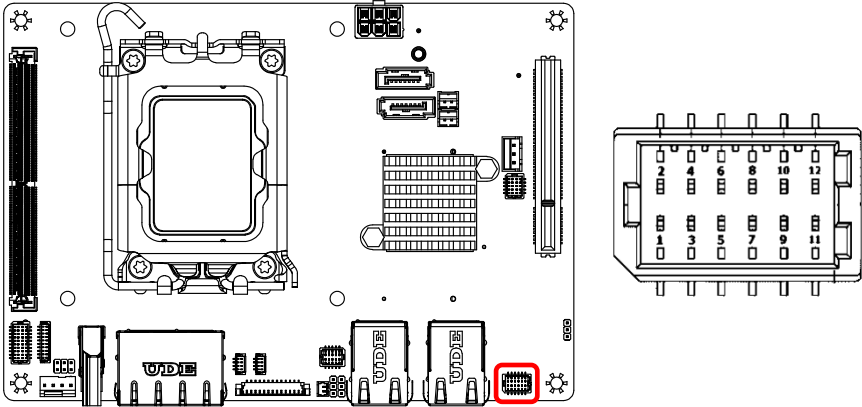

Pin	Pin Name	Signal Type	Pin	Pin Name	Signal Type
1	LOUT_R	OUT	2	MIC_L	IN
3	LOUT_L	OUT	4	MIC_R	IN
5	JD_LOUT	IN	6	JD_MIC	IN
7	AUD_GND	GND	8	AUD_GND	GND
9	LINE_R_IN	IN	10	LIN_R	IN
11	+VDD_AUD	PWR	12	LIN_L	IN

2.4.4 +5V Output for SATA HDD (CN6)

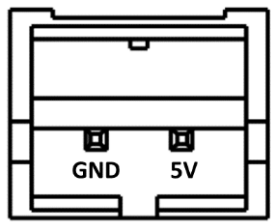
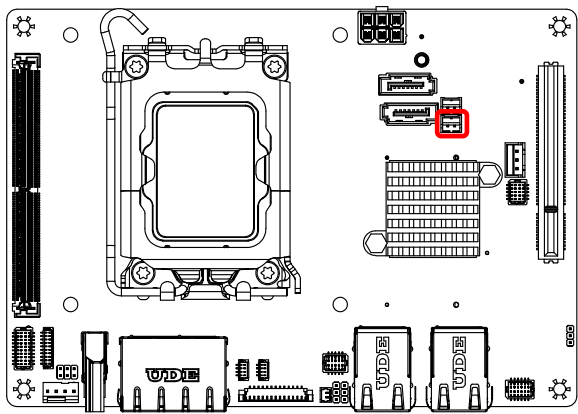

Pin	Pin Name	Signal Type	Signal Level
1	+5V	PWR	+5V(1A)
2	GND	GND	

2.4.5 External +5VSB Input (CN7)

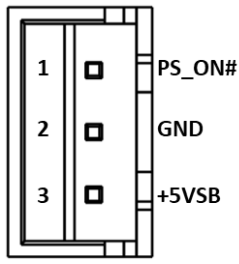
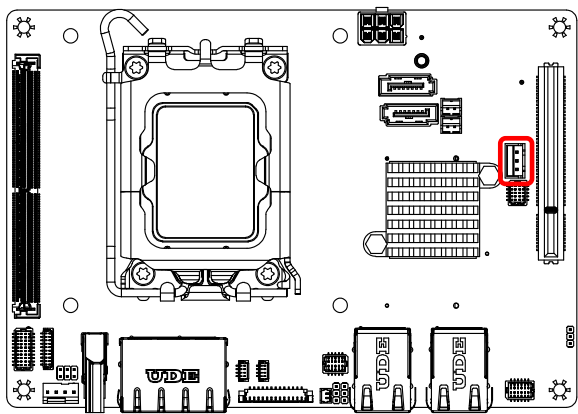

Pin	Pin Name	Signal Type	Signal Level
1	PS_ON#	OUT	+5V
2	GND	GND	
3	+5VSB	PWR	+5V (2.5A)

2.4.6 PCIe [x8] Slot (CN9)

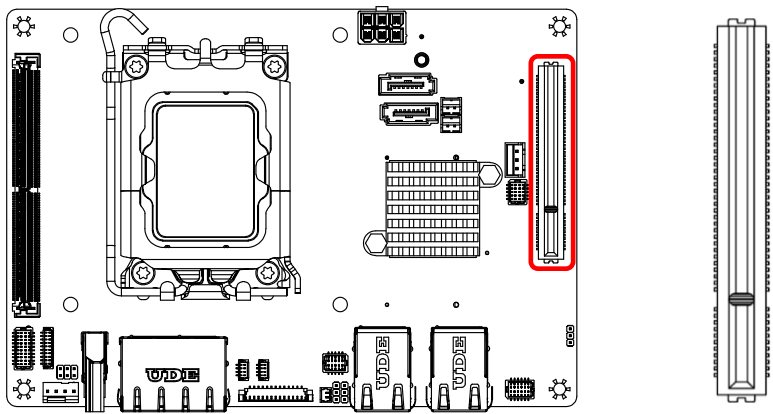

Standard configuration.

2.4.7 USB 2.0 Connector (CN13)

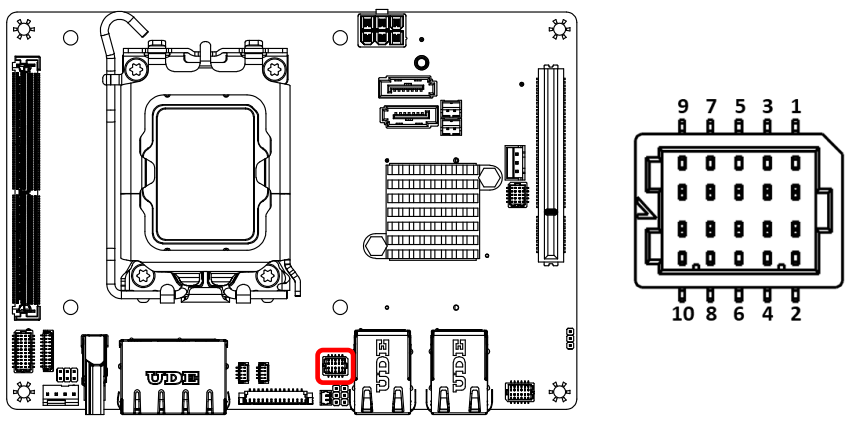

Pin	Pin Name	Pin	Signal Level
1	+5VSB (0.5A)	2	+5VSB (0.5A)
3	USB5_D-	4	USB6_D-
5	USB5_D+	6	USB6_D+
7	GND	8	GND
9	GND	10	GND

2.4.8 COM 1/2 Connector (RS-232/422/485) (CN14)

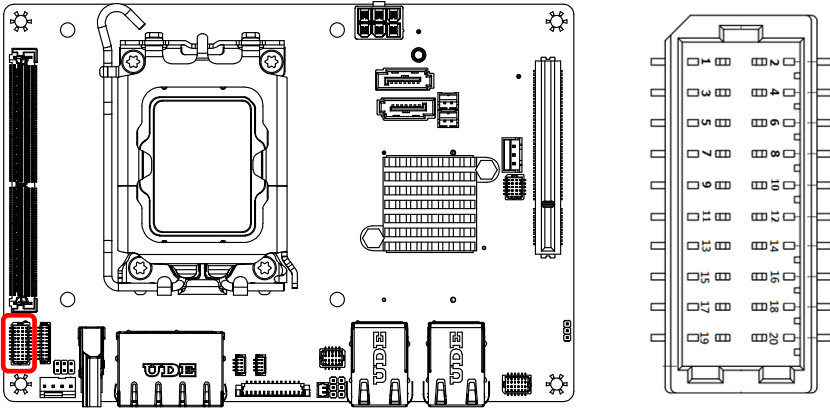

RS-232				
Pin	Pin	Pin Name	Signal Type	Signal Level
1	2	DCD	IN	
3	4	RX	IN	
5	6	TX	OUT	±5V
7	8	DTR	OUT	±5V
9	10	GND	GND	
11	12	DSR	IN	
13	14	RTS	OUT	±5V
15	16	CTS	IN	
17	18	RI	IN	
19	20	NC		

RS-485				
Pin	Pin	Pin Name	Signal Type	Signal Level
1	2	RS485_D-	I/O	±5V
3	4	RS485_D+	I/O	±5V
5	6	NC		
7	8	NC		
9	10	GND	GND	
11	12	NC		
13	14	NC		
15	16	NC		
	18	RI/+5V/+12V(0.5A)	PWR	+5V/+12V
17		RI	IN	
19	20	NC		

RS-422				
Pin	Pin	Pin Name	Signal Type	Signal Level
1	2	RS422_TX-	OUT	±5V
3	4	RS422_TX+	OUT	±5V
5	6	RS422_RX+	IN	
7	8	RS422_RX-	IN	
9	10	GND	GND	
11	12	NC		
13	14	NC		
15	16	NC		
	18	RI/+5V/+12V(0.5A)	PWR	+5V/+12V
17		RI	IN	
19	20	NC		

Note: COM 1 & COM 2 RS-232/422/485 can be set by BIOS setting. Default is RS-232.

Note: COM 1 Pin 17 RI only, COM 2 Pin 18 function can be selected by JP4 (RI/+5V/+12V).

2.4.9 GPIO Port (CN20)

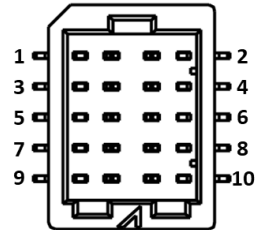
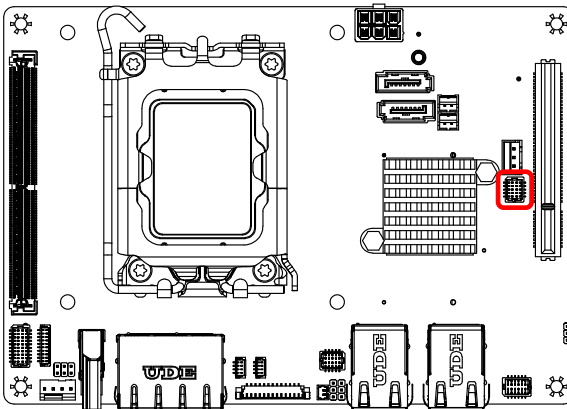

Pin	Signal	Pin	Signal
1	PD0	2	PD1
3	PD2	4	PD3
5	PD4	6	PD5
7	PD6	8	PD7
9	+V5S(0.5A)	10	GND

2.4.10 LAN 3 LED (CN21)

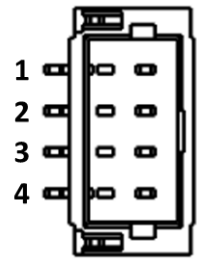
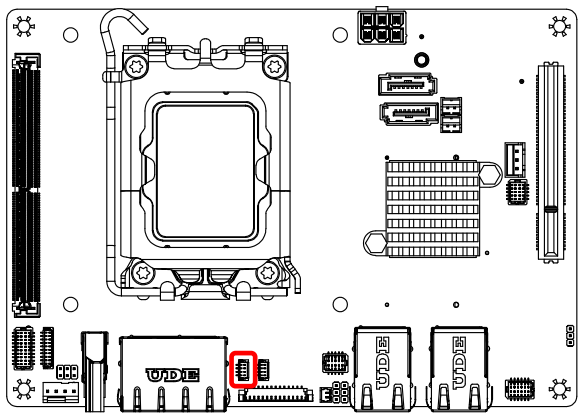

Left LAN LED (CN48)			
Pin	Pin Name	Signal Type	Signal Level
1	+V3P3A_LAN3	PWR	3.3V
2	LAN3_LED_1000#	IN/OUT	3.3V
3	LAN3_LED_LNK#_ACT	IN/OUT	3.3V
4	LAN3_LED_2500#	GND	GND

2.4.11 SPI BIOS Debug Port (CN27)

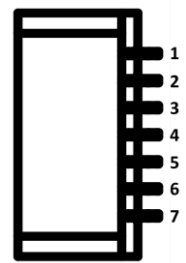
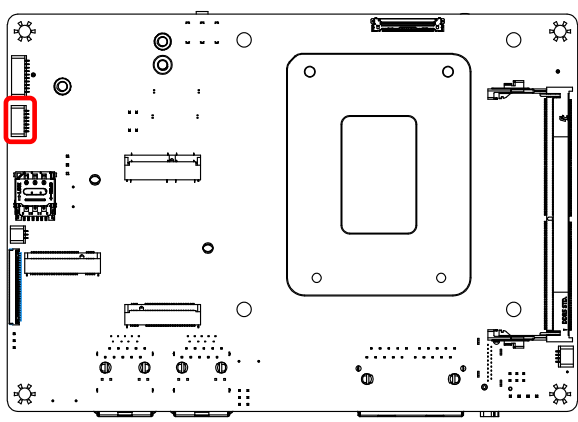

Pin	Pin Name	Signal Type	Signal Level
1	SPI_MISO	OUT	
2	GND	GND	GND

Pin	Pin Name	Signal Type	Signal Level
3	SPI_CLK	IN	
4	+3.3VSB	PWR	+3.3V
5	SPI_MOSI	IN	
6	SPI_CS	IN	
7	NC		

2.4.12 M.2 2230 E-Key (CN28)

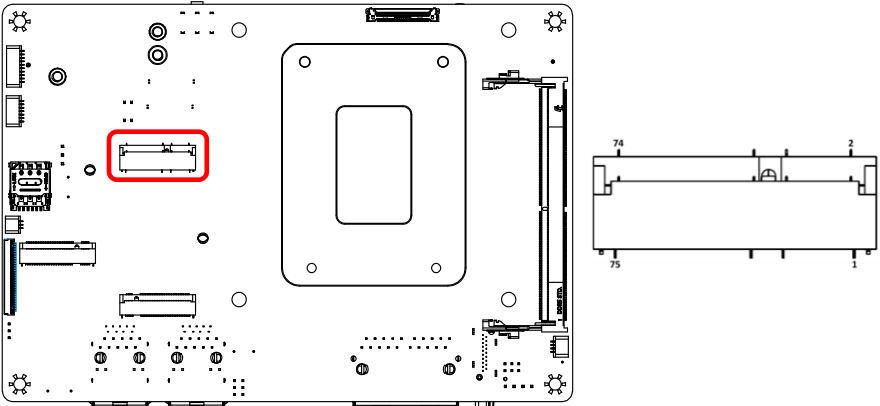

Standard specifications.

2.4.13 Nano SIM Card Socket (CN29)

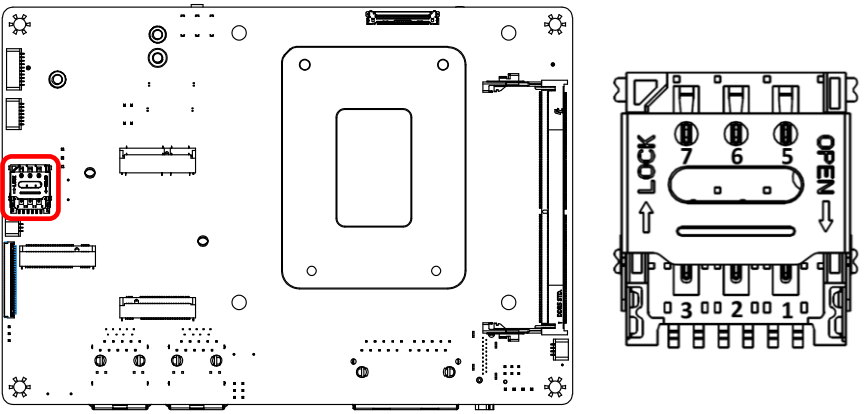

Pin	Pin Name	Signal Type	Signal Level
1	UIM_PWR	PWR	-
2	UIM_RST	OUT	-
3	UIM_CLK	OUT	-
4	N/A	N/A	-
5	GND	GND	GND
6	N/A	N/A	-
7	UIM_DATA	IN/OUT	-

2.4.14 M.2 3042/3052 B-Key (CN30)

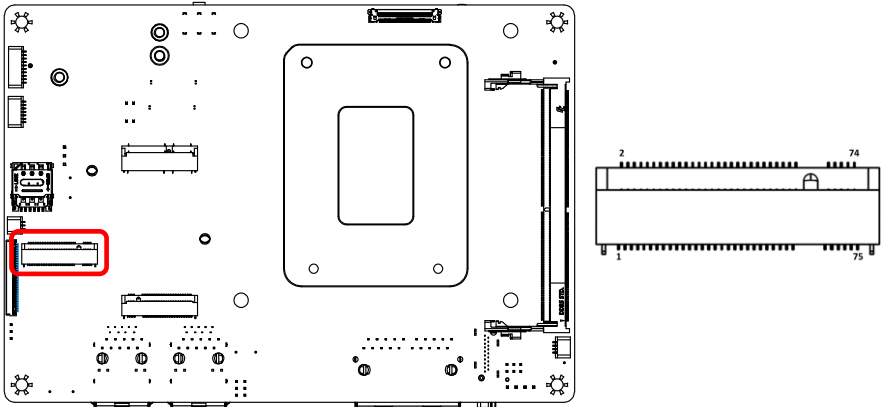

Standard specifications.

2.4.15 PCIe [x2] FPC Connector (CN31)

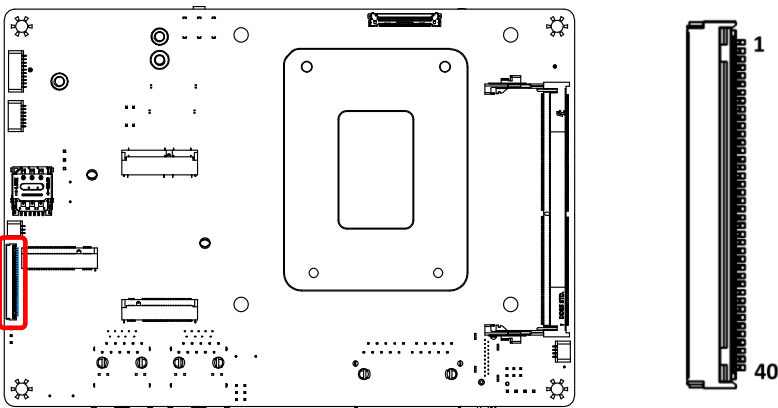

Pin	Pin Name	Signal Type	Signal Level
1	+V3P3S	PWR	3.3V
2	+V3P3S	PWR	3.3V
3	+V3P3S	PWR	3.3V
4	SMB_DATA	IN/OUT	
5	SMB_CLK	OUT	
6	BUF_PLT_RST#		
7	+V3P3A	PWR	3.3V
8	GND	GND	
9	NC		
10	NC		
11	GND	GND	
12	PCIE_6_RXP	DIFF	
13	PCIE_6_RXN	DIFF	
14	GND	GND	
15	PCIE_5_RXP	DIFF	
16	PCIE_5_RXN	DIFF	
17	GND	GND	
18	NC		
19	NC		
20	GND	GND	
21	PCIE_6_TXN	DIFF	
22	PCIE_6_TXP	DIFF	
23	GND	GND	
24	PCIE_5_TXN	DIFF	
25	PCIE_5_TXP	DIFF	
26	GND	GND	
27	NC		
28	NC		
29	GND	GND	
30	PCIE_7_CLK_DN	DIFF	
31	PCIE_7_CLK_DP	DIFF	
32	GND	GND	
33	NC		
34	NC		
35	GND	GND	
36	+V12V	PWR	12V
37	+V12V	PWR	12V
38	+V12V	PWR	12V
39	+V12V	PWR	12V

Pin	Pin Name	Signal Type	Signal Level
40	+V12V	PWR	12V

2.4.16 M.2 2280 M-Key (CN32)

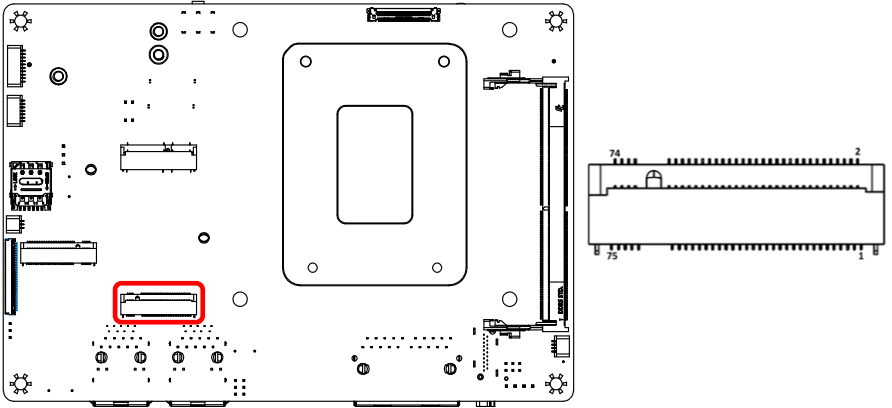

Standard specifications.

2.4.17 Time Sync (TCC) (CN33)

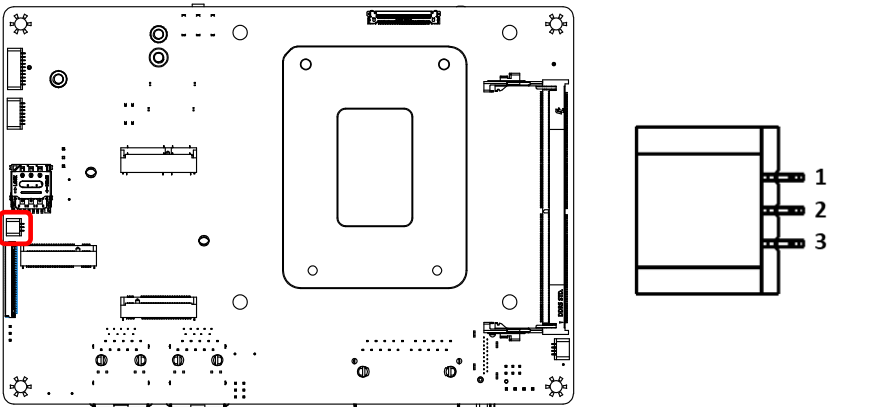

Pin	Pin Name	Signal Type	Signal Level
1	TIME_SYNC0	IN/OUT	3.3V
2	TIME_SYNC1	IN/OUT	3.3V
3	GND	GND	

2.4.18 +5V Output for SATA HDD (CN34)

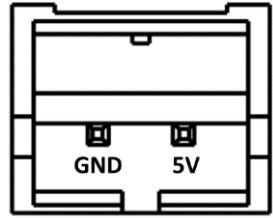
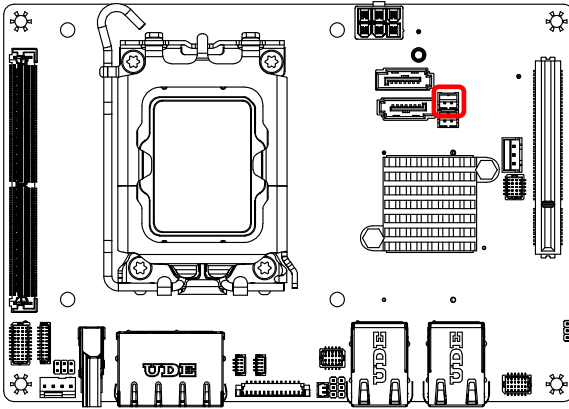

Pin	Pin Name	Signal Type	Signal Level
1	+5V	PWR	+5V(1A)
2	GND	GND	

2.4.19 CPU Fan (CN35)

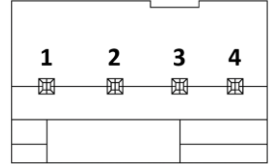
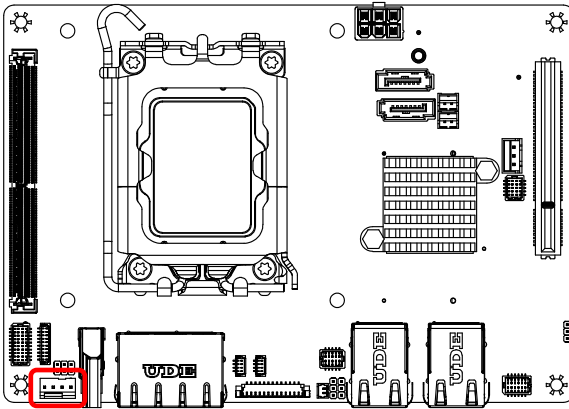

Pin	Pin Name	Signal Type	Signal Level
1	GND	GND	
2	FAN_POWER	PWR	+12V (1A)
3	FAN_TAC	IN	
4	FAN_CTL	OUT	

2.4.20 Vcore Programming Connector (CN39)

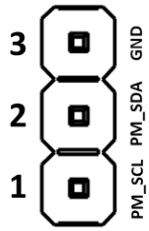
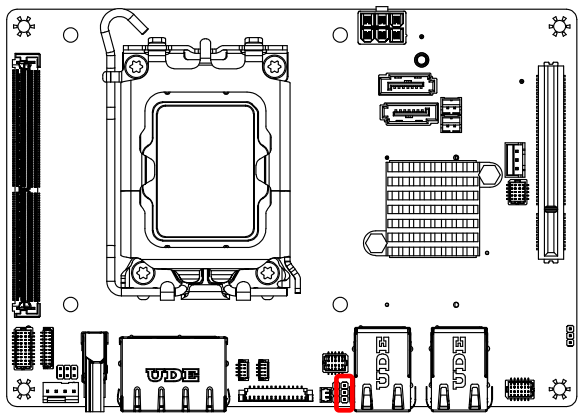

Pin	Pin Name	Signal Type	Signal Level
1	PM_SCL	IN/OUT	3.3V
2	PM_SDA	IN/OUT	3.3V
3	GND	GND	

2.4.21 6-Pin DC in ATX Connector (CN42)

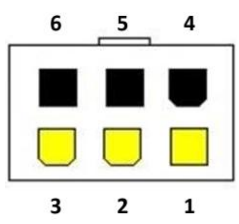
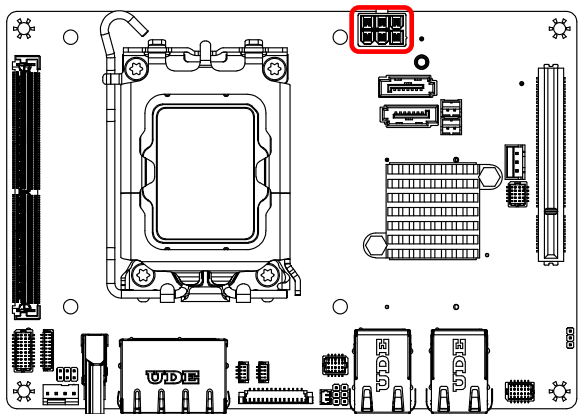

Pin	Pin Name	Signal Type	Signal Level
1	+VIN	PWR	12V
2	+VIN	PWR	12V
3	+VIN	PWR	12V
4	GND	GND	

Pin	Pin Name	Signal Type	Signal Level
5	GND	GND	
6	GND	GND	

Note: 12V only.

2.4.22 RJ-45 LAN Port I226 +USB 3.2 (CN45)

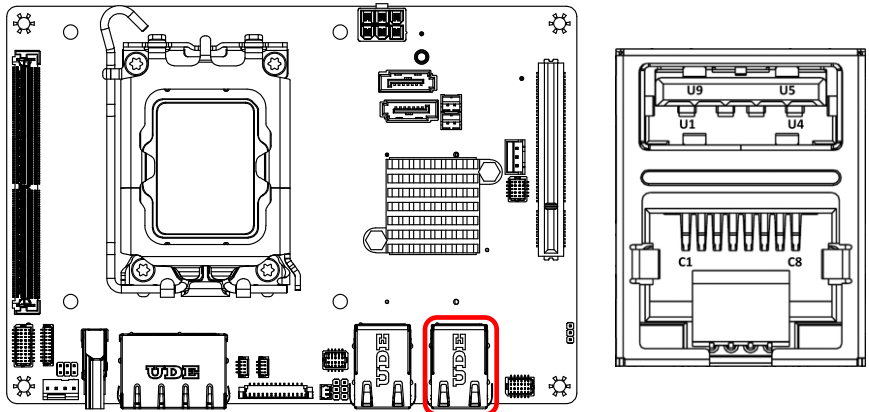

Pin	Pin Name	Signal Type	Signal Level
U1	+5VSB	PWR	+5V(0.9A)
U2	USB2_2_DN	DIFF	
U3	USB2_2_DP	DIFF	
U4	GND	GND	GND
U5	USB3_2_RXN	DIFF	
U6	USB3_2_RXP	DIFF	
U7	GND	GND	GND
U8	USB3_2_TXN	DIFF	
U9	USB3_2_TXP	DIFF	
R2	LAN2_MDIO_P	DIFF	2.5G
R3	LAN2_MDIO_N	DIFF	2.5G
R4	LAN2_MDIO1_P	DIFF	2.5G
R5	LAN2_MDIO1_N	DIFF	2.5G
R6	LAN2_MDIO2_P	DIFF	2.5G
R7	LAN2_MDIO2_N	DIFF	2.5G
R8	LAN2_MDIO3_P	DIFF	2.5G
R9	LAN2_MDIO3_N	DIFF	2.5G

2.4.23 RJ-45 LAN Port I219 + USB 3.2 (CN46)

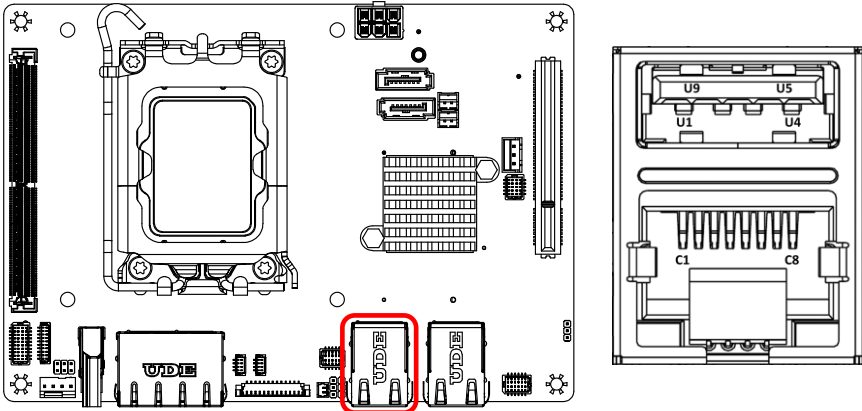

Pin	Pin Name	Signal Type	Signal Level
U1	+5VSB	PWR	+5V(0.9A)
U2	USB2_1_DN	DIFF	
U3	USB2_1_DP	DIFF	
U4	GND	GND	GND
U5	USB3_1_RXN	DIFF	
U6	USB3_1_RXP	DIFF	
U7	GND	GND	GND
U8	USB3_1_TXN	DIFF	
U9	USB3_1_TXP	DIFF	
R2	LAN1_MDI0_P	DIFF	1G
R3	LAN1_MDI0_N	DIFF	1G
R4	LAN1_MDI1_P	DIFF	1G
R5	LAN1_MDI1_N	DIFF	1G
R6	LAN1_MDI2_P	DIFF	1G
R7	LAN1_MDI2_N	DIFF	1G
R8	LAN1_MDI3_P	DIFF	1G
R9	LAN1_MDI3_N	DIFF	1G

2.4.24 Dual 2.5GbE LAN (LAN 3: Left, LAN 4: Right) (CN48)

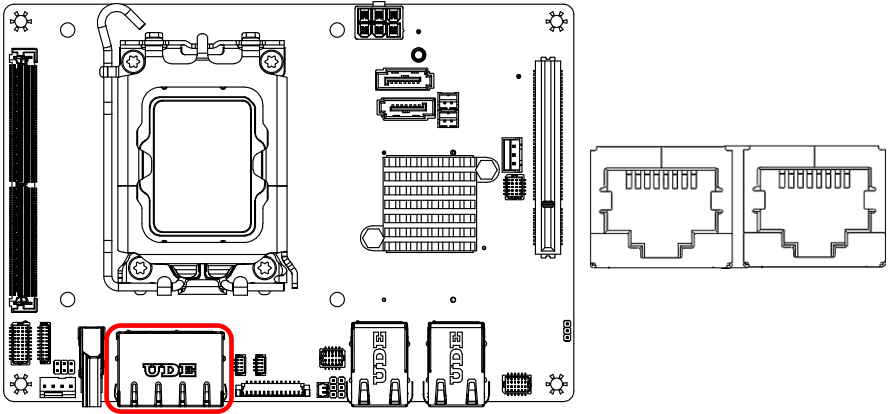

Pin	Pin Name	Pin	Pin Name
1P1	LAN3_MDIO_P	2P1	LAN4_MDIO_P
1P2	LAN3_MDIO_N	2P2	LAN4_MDIO_N
1P3	LAN3_MD11_P	2P3	LAN4_MD11_P
1P4	LAN3_MD11_N	2P4	LAN4_MD11_N
1P5	1CT5	2P5	2CT5
1P6	1CT6	2P6	2CT6
1P7	LAN3_MD12_P	2P7	LAN4_MD12_P
1P8	LAN3_MD12_N	2P8	LAN4_MD12_N
1P9	LAN3_MD13_P	2P9	LAN4_MD13_P
1P10	LAN3_MD13_N	2P10	LAN4_MD13_N

2.4.25 LAN 4 LED (CN51)

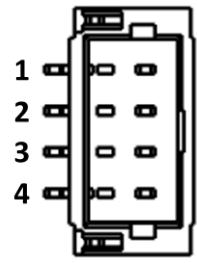
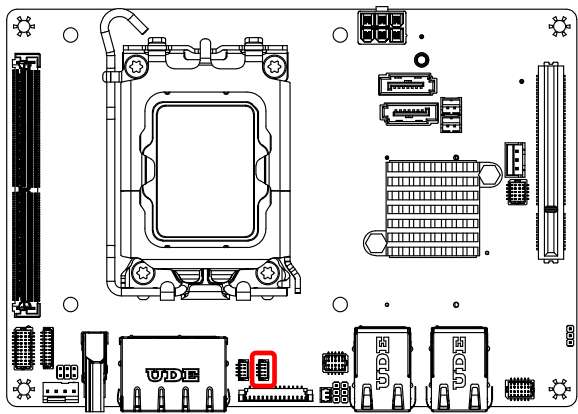

Right LAN LED (CN48)			
Pin	Pin Name	Signal Type	Signal Level
1	+V3P3A_LAN4	PWR	3.3V
2	LAN4_LED_1000#	IN/OUT	3.3V
3	LAN4_LED_LNK#_ACT	IN/OUT	3.3V
4	LAN4_LED_2500#	GND	GND

2.4.26 Front Panel (CN52)

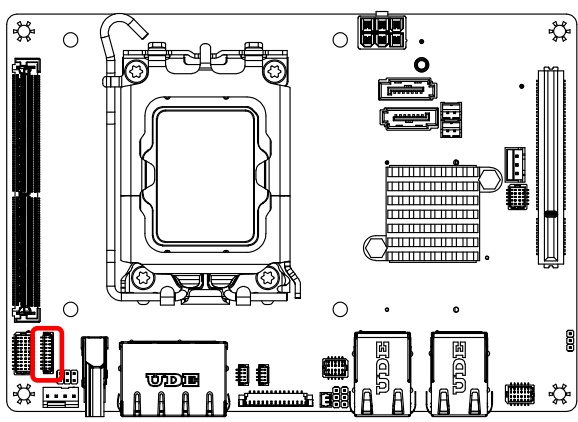

Pin	Pin Name	Pin	Pin Name
Pin 1	PWR_BTN-	Pin 2	PWR_BTN+
Pin 3	HDD_LED-	Pin 4	HDD_LED+

Pin	Pin Name	Pin	Pin Name
Pin 5	SPEAKER-	Pin 6	SPEAKER+
Pin 7	PWR_LED-	Pin 8	PWR_LED+
Pin 9	H/W RESET-	Pin 10	H/W RESET+

2.4.27 HDMI Connector (CN54)

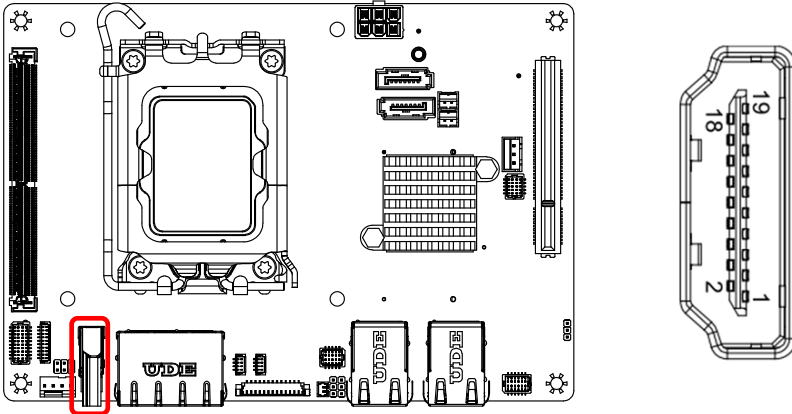

Pin	Pin Name	Signal Type	Signal Level
1	HDMI_TX2+	DIFF	
2	GND	GND	
3	HDMI_TX2-	DIFF	
4	HDMI_TX1+	DIFF	
5	GND	GND	
6	HDMI_TX1-	DIFF	
7	HDMI_TX0+	DIFF	
8	GND	GND	
9	HDMI_TX0-	DIFF	
10	HDMI_CLK+	DIFF	
11	GND	GND	
12	HDMI_CLK-	DIFF	
13	NC		
14	NC		
15	DDC_CLK	I/O	+5V
16	DDC_DATA	I/O	+5V
17	GND	GND	
18	+5V	PWR	+5V
19	HDMI_HPD		

2.4.28 SMBus/I2C (CN55)

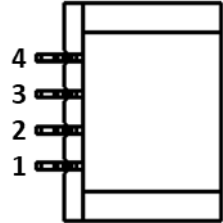
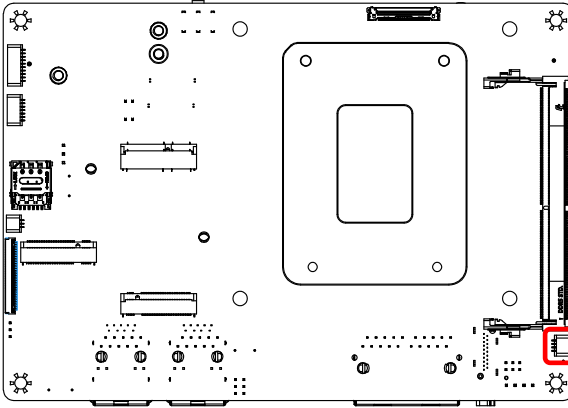

Pin	Pin Name	Signal Type	Signal Level
1	+V3P3S	PWR	3.3V
2	SMB_DATA/I2C_DATA	IN/OUT	3.3V
3	SMB_CLK/I2C_CLK	IN/OUT	3.3V
4	GND	GND	GND

Note: Default function is SMBus.

2.4.29 eSPI Connector for Debug (CN56)

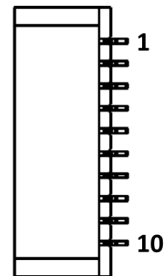
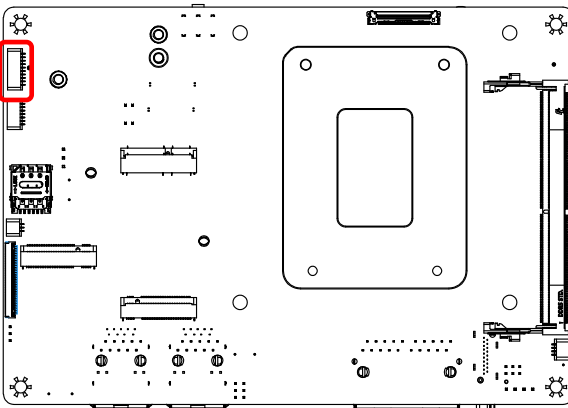

Pin	Pin Name	Signal Type	Signal Level
1	+V3P3A	PWR	+3.3V
2	ESPI_CLK_EC_R	OUT	+1.8V

Pin	Pin Name	Signal Type	Signal Level
3	GND	GND	GND
4	ESPI_RST_EC_R_N	OUT	+1.8V
5	ESPI_CS_EC_R_N	OUT	+3.3V
6	+V3P3S	PWR	+3.3V
7	ESPI_IO3_EC_R	IN/OUT	+1.8V
8	ESPI_IO2_EC_R	IN/OUT	+1.8V
9	ESPI_IO1_EC_R	IN/OUT	+1.8V
10	ESPI_IO0_EC_R	IN/OUT	+3.3V

2.4.30 eDP Connector. (CN57)

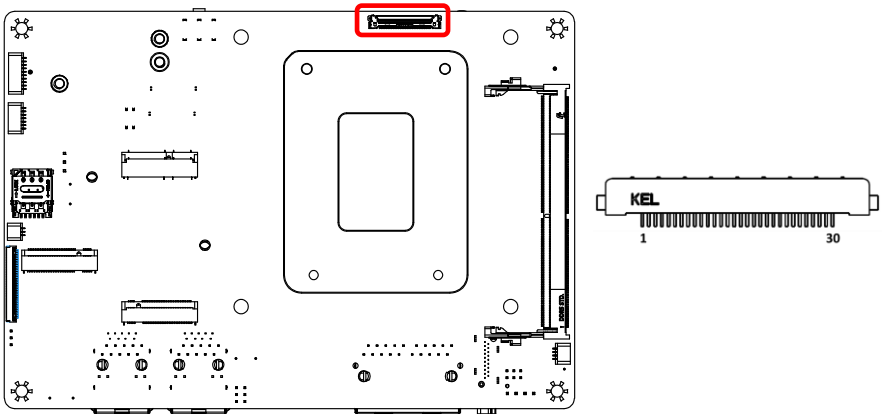

Pin	eDP	Signal Type	Signal Level
1	+VDD	PWR	+3.3V
2	+VDD	PWR	+3.3V
3	+VDD	PWR	+3.3V
4	GND	GND	
5	EDP_LANE2_DN	DIFF	
6	EDP_LANE2_DP	DIFF	
7	GND	GND	
8	EDP_LANE1_DN	DIFF	
9	EDP_LANE1_DP	DIFF	
10	GND	GND	
11	EDP_LANE0_DN	DIFF	
12	EDP_LANE0_DP	DIFF	
13	GND	GND	
14	EDP_LANE3_DN	DIFF	

Pin	eDP	Signal Type	Signal Level
15	EDP_LANE3_DP	DIFF	
16	GND	GND	
17	EDP_AUX_DN	DIFF	
18	EDP_AUX_DP	DIFF	
19	GND	GND	
20	DDIO_BKLTCTL_R		
21	LVD1_DDC_DATA		
22	DDIO_BKLTEN_R		
23	DDIO_HPD		
24	GND	GND	
25	GND	GND	
26	GND	GND	
27	+VCC_EDP_BKLT	PWR	+12V(Default) /+5V
28	+VCC_EDP_BKLT	PWR	+12V(Default) /+5V
29	+VCC_EDP_BKLT	PWR	+12V(Default) /+5V
30	+VCC_EDP_BKLT	PWR	+12V(Default) /+5V

2.4.31 DDR5 SODIMM Slot (DIMM1)

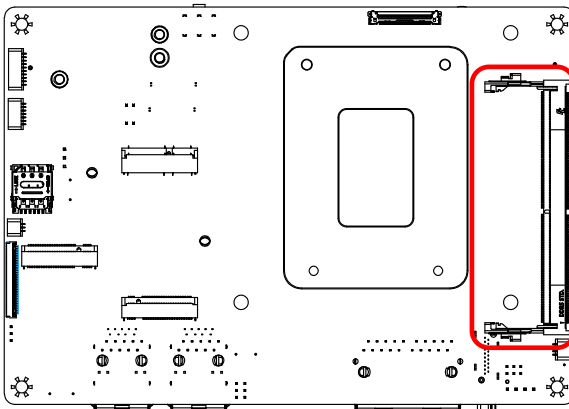

Standard specification.

2.4.32 DDR5 SODIMM Slot (DIMM2)

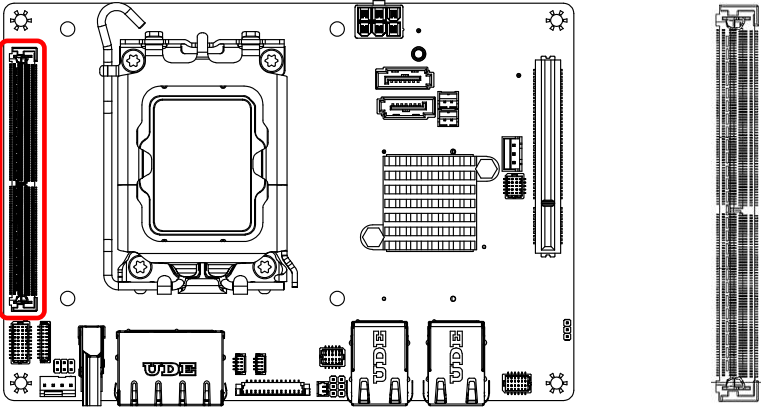

Standard specification.

2.5 CPU Cooler Installation

Installation Instructions

1. Do not apply any thermal grease to the cooler - the required amount has already been applied.
2. The back plate should be pre-attached to the underside of the motherboard.

Remember to peel off the insulation slice liner prior to installation.

3. Place the cooler directly on top of the CPU so that the heatsink screws are aligned with the mounting holes on the back plate.
4. Make sure screwdriver torque setting is no more than 5.0 kgf-cm (4.3 lbf-in) and keep heatsink screws direction vertical.
5. Screw in two diagonal screws (i.e. the #1 and #2 screws) until they are just snug (do not fully tighten), then do the same with the remaining two diagonal screws.
6. Finish by fully tightening all four screws.
7. Connect the fan cable to the CPU fan connector on the motherboard.

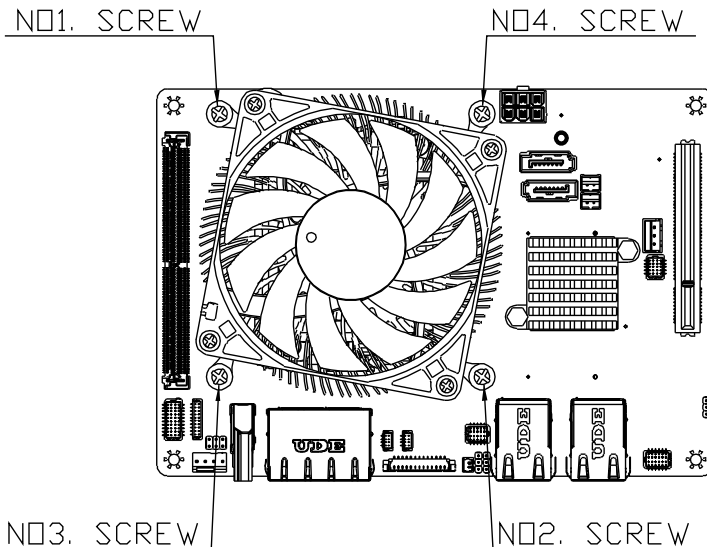

Part No: EPIC-RPS9-FAN01

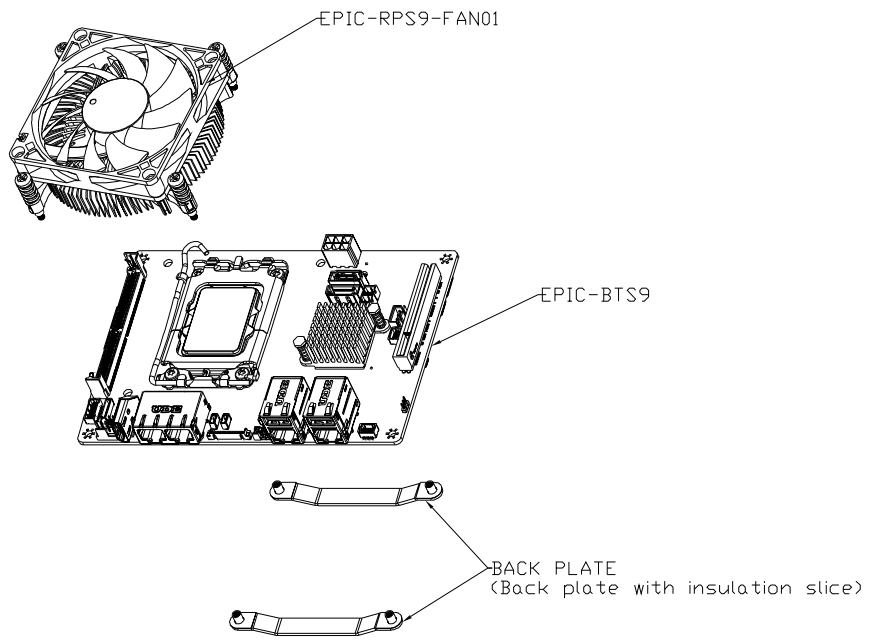

Chapter 3

AMI BIOS Setup

3.1 System Test and Initialization

These routines test and initialize board hardware. If the routines encounter an error during the tests, you will either hear a few short beeps or see an error message on the screen. There are two kinds of errors: fatal and non-fatal. The system can usually continue the boot up sequence with non-fatal errors.

System configuration verification

These routines check the current system configuration stored in the CMOS memory and BIOS NVRAM. If system configuration is not found or system configuration data error is detected, system will load optimized default and re-boot with this default system configuration automatically.

There are four situations in which you will need to setup system configuration:

1. You are starting your system for the first time
2. You have changed the hardware attached to your system
3. The system configuration is reset by Clear-CMOS jumper
4. The CMOS memory has lost power and the configuration information has been erased.

The EPIC-BTS9 CMOS memory has an integral lithium battery backup for data retention. However, you will need to replace the battery unit when it finally runs down.

3.2 AMI BIOS Setup

AMI BIOS ROM has a built-in Setup program that allows users to modify the basic system configuration. This type of information is stored in battery-backed CMOS RAM and BIOS NVRAM so that it retains the Setup information when the power is turned off.

Entering Setup

Power on the computer and press or <ESC> immediately. This will allow you to enter Setup.

Main

Set the date, use tab to switch between date elements.

Advanced

Enable/disable boot option for legacy network devices.

Chipset

Host bridge parameters.

Security

Set setup administrator password.

Boot

Enables/disables quiet boot option.

Save & Exit

Exit system setup after saving the changes.

MEBx

Set management firmware and Intel ME configuration user interface.

3.3 Setup Submenu: Main

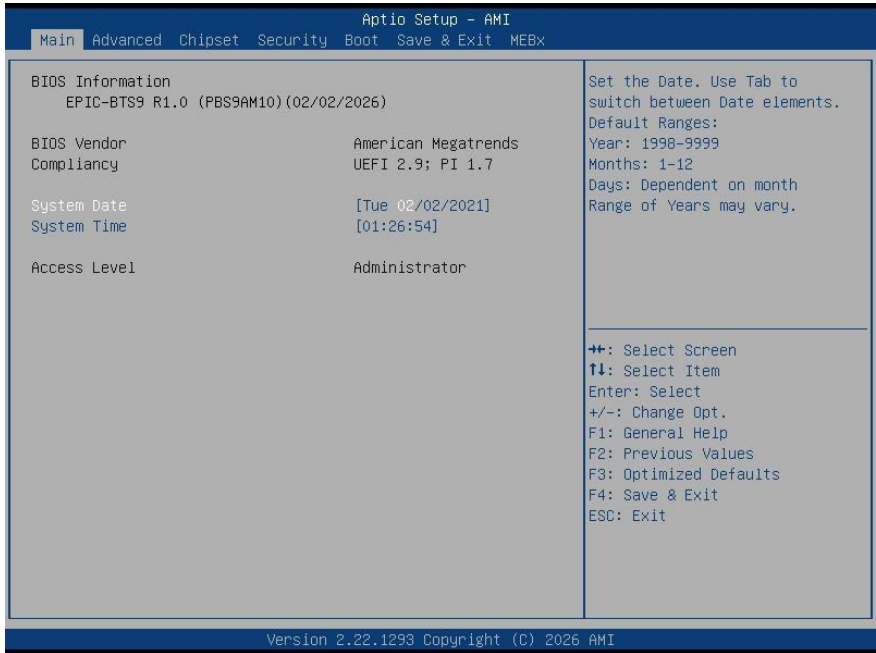

3.4 Setup Submenu: Advanced

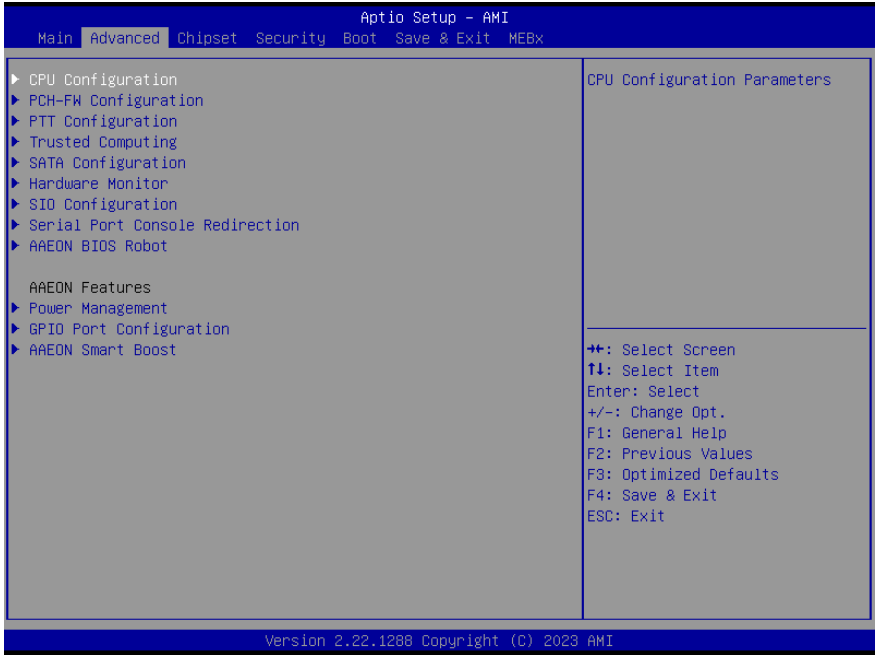

3.4.1 CPU Configuration

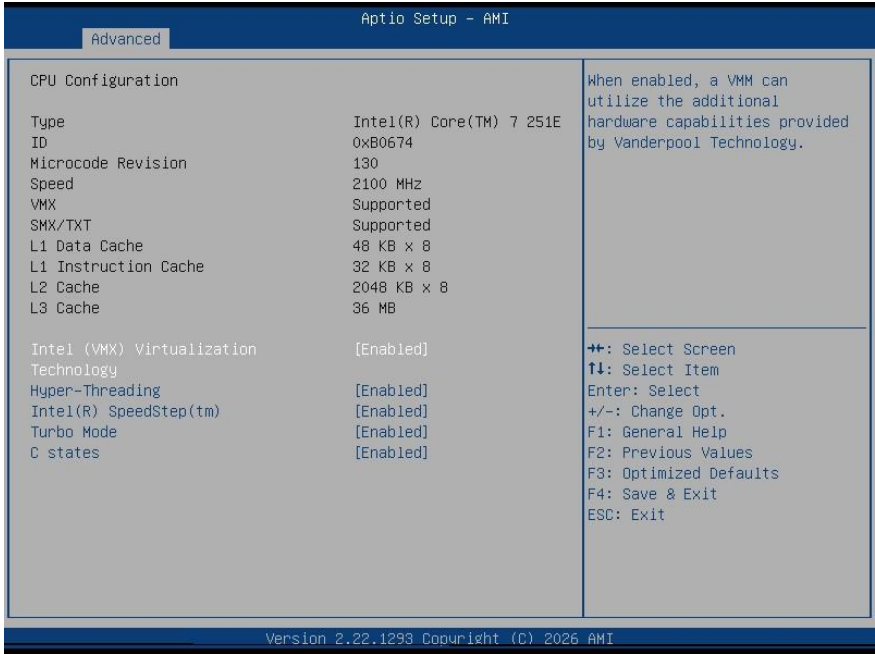

Options Summary		
Intel (VMX) Virtualization Technology	Disabled	
	Enabled	Optimal Default, Failsafe Default
When enabled, a VMM can utilize the additional hardware capabilities provided by Vanderpool Technology.		
Hyper-Threading	Disabled	
	Enabled	Optimal Default, Failsafe Default
Enable or Disable Hyper-Threading Technology.		
Intel® SpeedStep™	Disabled	
	Enabled	Optimal Default, Failsafe Default
Allows more than two frequency ranges to be supported.		
Turbo Mode	Disabled	
	Enabled	Optimal Default, Failsafe Default
Enable or Disable processor Turbo Mode (requires EMTTM enable too). AUTO means enabled.		

Options Summary		
C states	Disabled	
	Enabled	Optimal Default, Failsafe Default
Enable/Disable CPU Power Management. Allows CPU to go to C states when it's not 100 utilized.		

3.4.2 PCH-FW Configuration

Aptio Setup - AMI

Advanced

ME Firmware Version 16.1.30.2255 ME Firmware Mode Normal Mode ME Firmware SKU Corporate SKU ME Firmware Status 1 0x90000255 ME Firmware Status 2 0x39858106 ▶ Firmware Update Configuration	Configure Management Engine Technology Parameters ++: Select Screen ↑↓: Select Item Enter: Select +/-: Change Opt. F1: General Help F2: Previous Values F3: Optimized Defaults F4: Save & Exit ESC: Exit
---	--

Version 2.22.1288 Copyright (C) 2023 AMI

3.4.3 Firmware Update Configuration

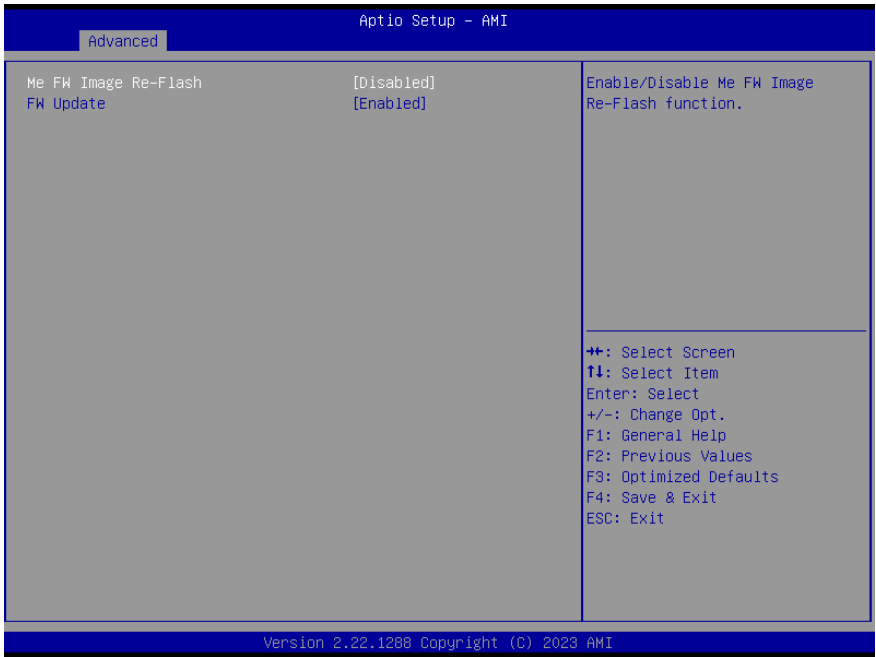

Options Summary		
Me FW Image Re-Flash	Enabled	
	Disabled	Optimal Default, Failsafe Default
Enable/Disable Me FW Image Re-Flash function.		
FW Update	Disabled	
	Enabled	Optimal Default, Failsafe Default
Enable/Disable ME FW Update function.		

3.4.4 PTT Configuration

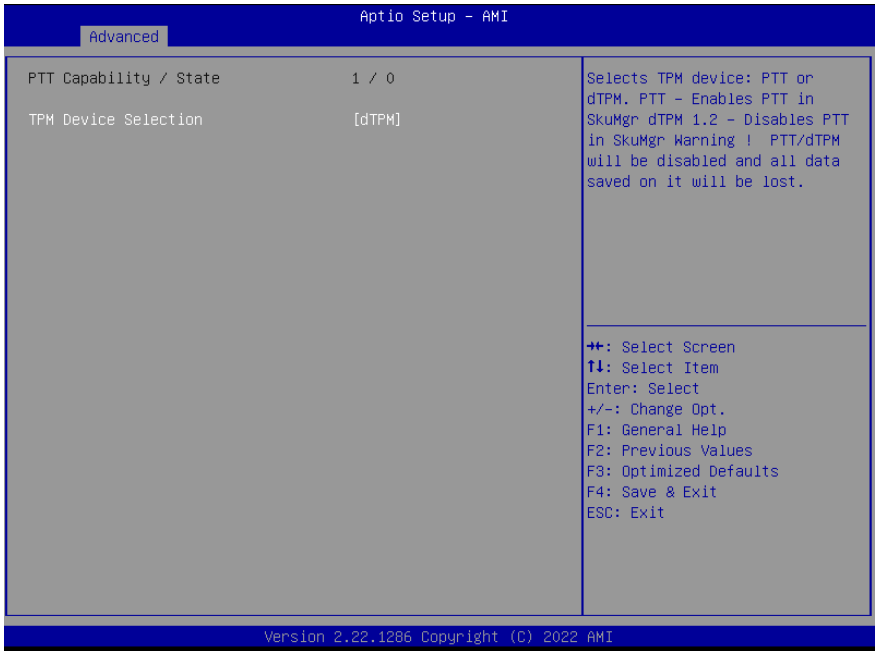

Options Summary		
TPM Device Selection	dTPM	Optimal Default, Failsafe Default
	PTT	
<p>Selects TPM device: PTT or discrete TPM. PTT - enables PTT in SkuMgr. dTPM - disables PTT in SkuMgr. Warning! PTT/dTPM will be disabled and all data saved on it will be lost.</p>		

3.4.5 Trusted Computing

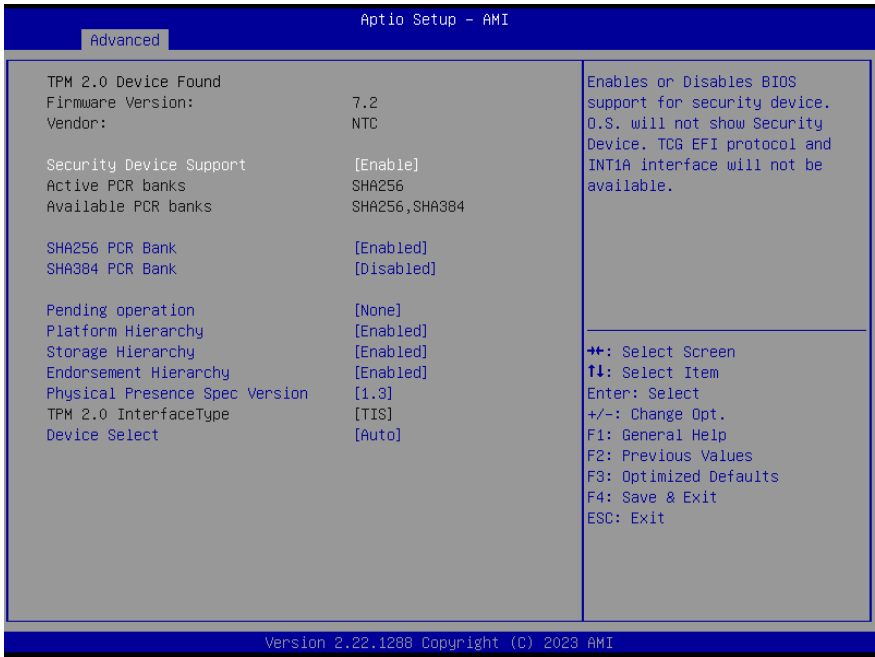

Options Summary		
Security Device Support	Enable	Optimal Default, Failsafe Default
	Disable	
Enables or Disables BIOS support for security device. O.S. will not show Security Device. TCG EFI protocol and INT1A interface will not be available.		
SHA256 PCR Bank	Enabled	Optimal Default, Failsafe Default
	Disabled	
Enable or Disable SHA256 PCR Bank.		
SHA384 PCR Bank	Enabled	Optimal Default, Failsafe Default
	Disabled	
Enable or Disable SHA384 PCR Bank.		
Pending operation	None	Optimal Default, Failsafe Default
	TPM Clear	
Schedule an Operation for the Security Device.		
NOTE: Your Computer will reboot during restart in order to change State of Security Device.		

Options Summary		
Platform Hierarchy	Enabled	Optimal Default, Failsafe Default
	Disabled	
Enable or Disable Platform Hierarchy.		
Storage Hierarchy	Enabled	Optimal Default, Failsafe Default
	Disabled	
Enable or Disable Storage Hierarchy.		
Endorsement Hierarchy	Enabled	Optimal Default, Failsafe Default
	Disabled	
Enable or Disable Endorsement Hierarchy.		
Physical Presence Spec Version	1.3	Optimal Default, Failsafe Default
	1.2	
Select to Tell O.S. to support PPI Spec Version 1.2 or 1.3. Note some HCK tests might not support 1.3.		
Device Select	Auto	Optimal Default, Failsafe Default
	TPM 1.2	
	TPM 2.0	
TPM 1.2 will restrict support to TPM 1.2 devices. TPM 2.0 will restrict support to TPM 2.0 devices. Auto will support both with the default set to TPM 2.0 devices if not found. TPM 1.2 devices will be enumerated.		

3.4.6 SATA Configuration

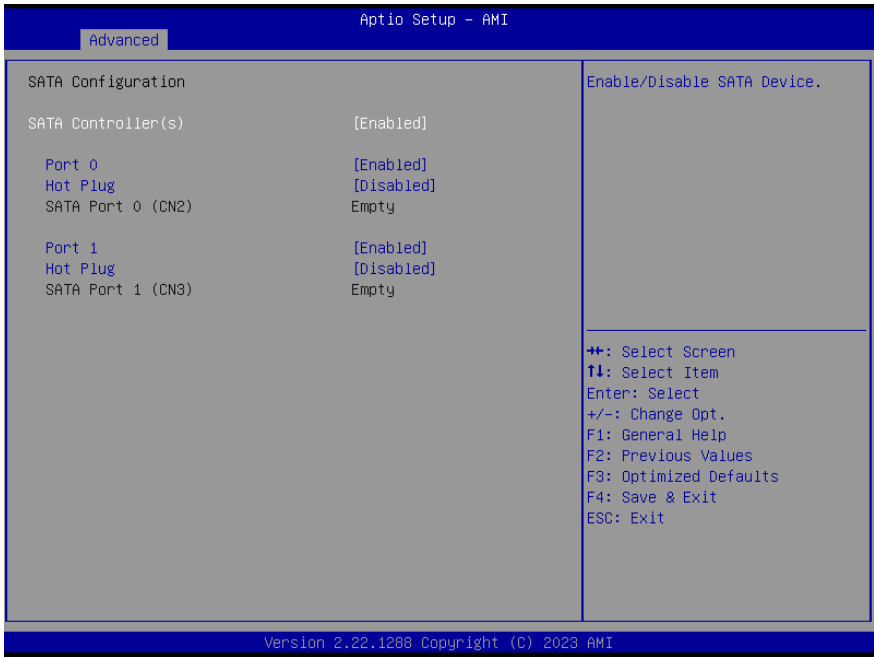

Options Summary		
SATA Controller(s)	Enabled	Optimal Default, Failsafe Default
	Disabled	
Enable/Disable SATA Device.		
Port 0	Enabled	Optimal Default, Failsafe Default
	Disabled	
Enable or Disable SATA Port.		
Hot Plug	Disabled	Optimal Default, Failsafe Default
	Enabled	
Designates this port as Hot Pluggable.		
Port 1	Enabled	Optimal Default, Failsafe Default
	Disabled	
Enable or Disable SATA Port.		
Hot Plug	Disabled	Optimal Default, Failsafe Default
	Enabled	
Designates this port as Hot Pluggable.		

3.4.7 Hardware Monitor

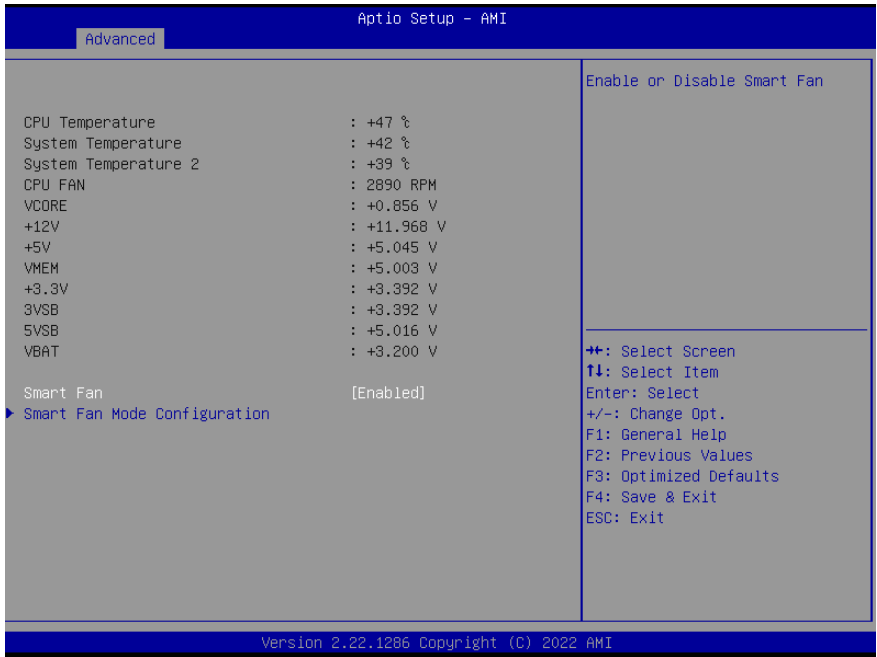

Options Summary		
Smart Fan	Disable	
	Enable	Optimal Default, Failsafe Default
Enables or Disables Smart Fan.		

3.4.7.1 Smart Fan Mode Configuration

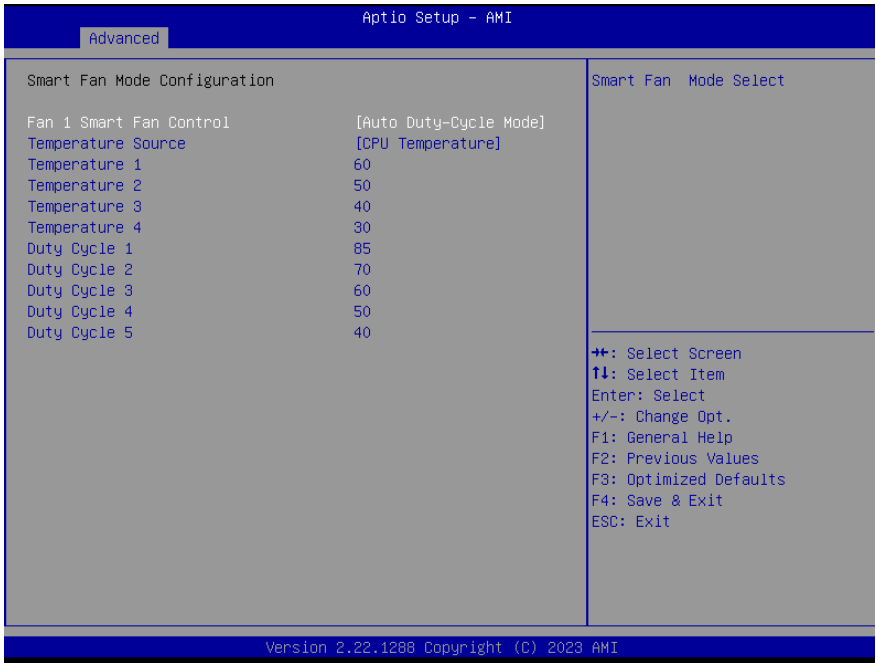

Options Summary		
Fan 1 Smart Fan Control	Manual Duty Mode	
	Auto Duty-Cycle Mode	Optimal Default, Failsafe Default
Smart Fan Mode Select.		
Temperature Source	CPU Temperature	Optimal Default, Failsafe Default
Select the monitored temperature source for this fan.		
Temperature 1	60	
Duty Cycle 1	85	
Auto fan speed control. Fan speed will follow different temperature by different duty cycle 1-100.		

3.4.8 SIO Configuration

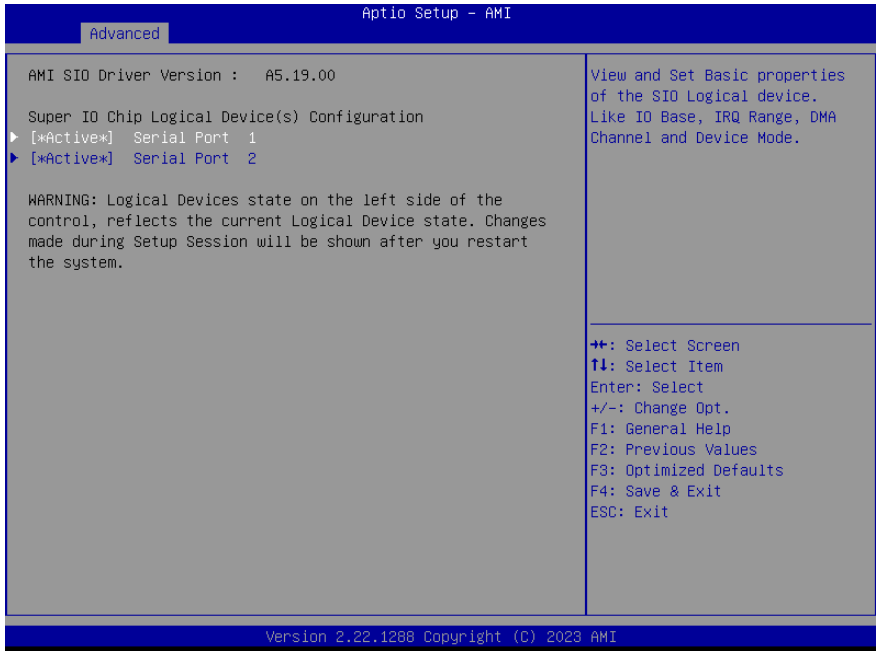

3.4.8.1 Serial Port 1 Configuration

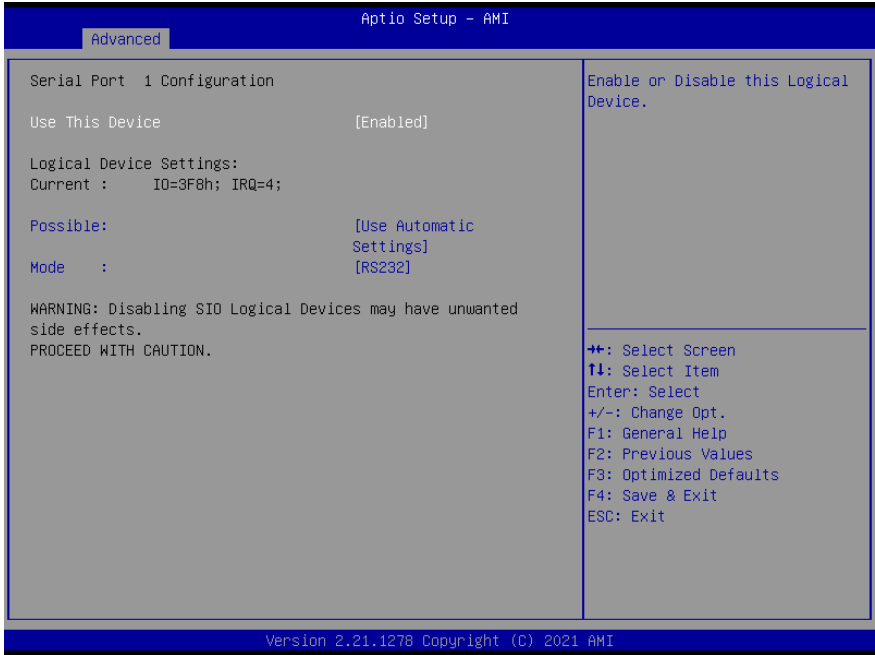

Options Summary		
Use This Device	Disable	
	Enable	Optimal Default, Failsafe Default
Enable or Disable this Logical Device.		
Possible:	Use Automatic Settings	Optimal Default, Failsafe Default
	IO=3F8h; IRQ=4	
	IO=2F8h; IRQ=3	
Allows user to change Device's Resource settings. New settings will be reflected on This Setup Page after System restarts.		
Mode:	RS232	Optimal Default, Failsafe Default
	RS422	
	RS485	
UART RS232, 422, 485 selection.		

3.4.8.2 Serial Port 2 Configuration

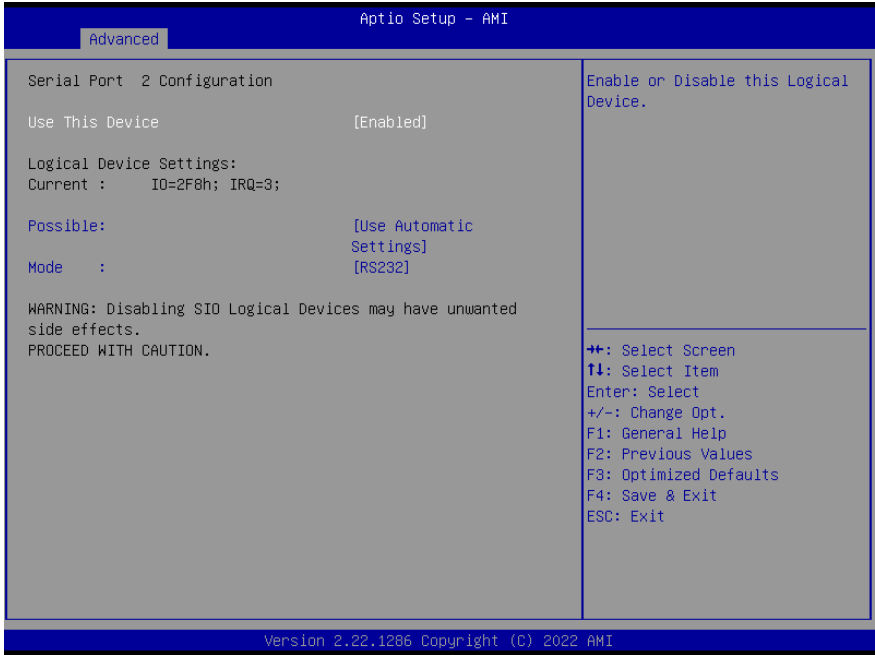

Options Summary		
Use This Device	Disable	
	Enable	Optimal Default, Failsafe Default
Enable or Disable this Logical Device.		
Possible:	Use Automatic Settings	Optimal Default, Failsafe Default
	IO=2F8h; IRQ=3	
	IO=3F8h; IRQ=4	
Allows user to change Device's Resource settings. New settings will be reflected on This Setup Page after System restarts.		
Mode:	RS232	Optimal Default, Failsafe Default
	RS422	
	RS485	
UART RS232, 422, 485 selection.		

3.4.9 Serial Port Console Redirection

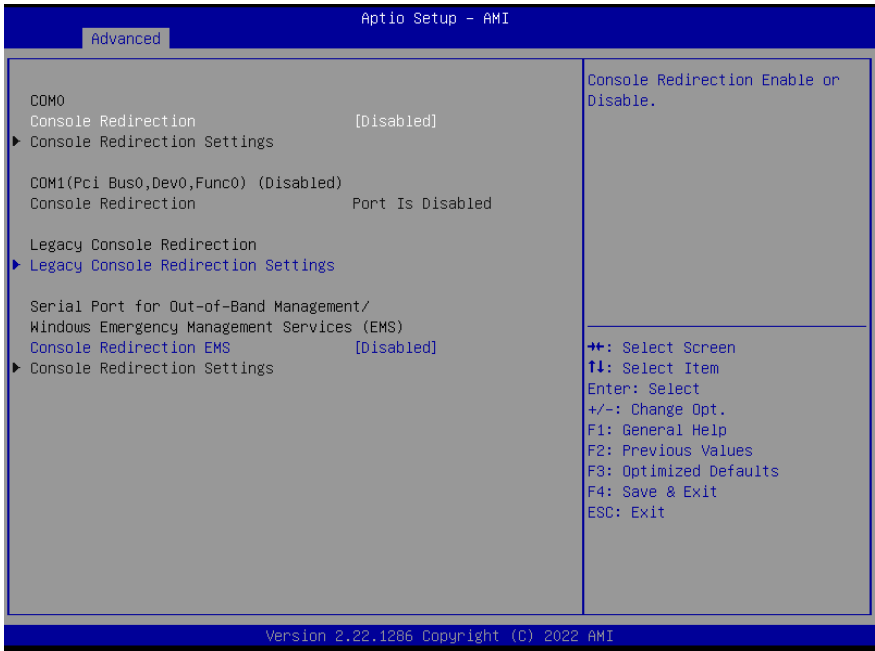

Options Summary		
Console Redirection	Disabled	Optimal Default, Failsafe Default
	Enabled	
Console Redirection Enable or Disable.		
Console Redirection EMS	Disabled	Optimal Default, Failsafe Default
	Enabled	
Console Redirection Enable or Disable.		

3.4.10 Legacy Console Redirection Settings

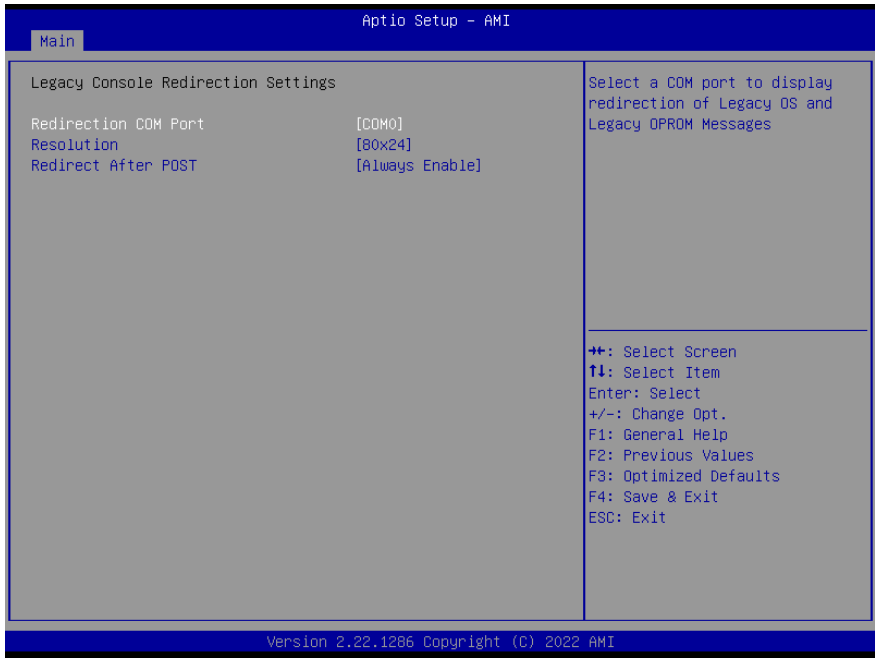

Options Summary		
Redirection COM port	COM0	Optimal Default, Failsafe Default
	COM1(Pci Bus0, Dev0, Func0) (Disabled)	
Select a COM Port to display redirection of Legacy OS and Legacy OPRM message.		
Resolution	80x24	Optimal Default, Failsafe Default
	80x25	
On Legacy OS, the number of Rows and Columns supported redirection.		
Redirect After POST	Always Enable	Optimal Default, Failsafe Default
	BootLoader	
When Bootloader is selected, then Legacy Console Redirection is disabled before booting to legacy OS. When Always Enable is selected, then Legacy Console Redirection is enabled for legacy OS. Default setting for this option is set to Always Enable.		

3.4.11 AAEON BIOS Robot

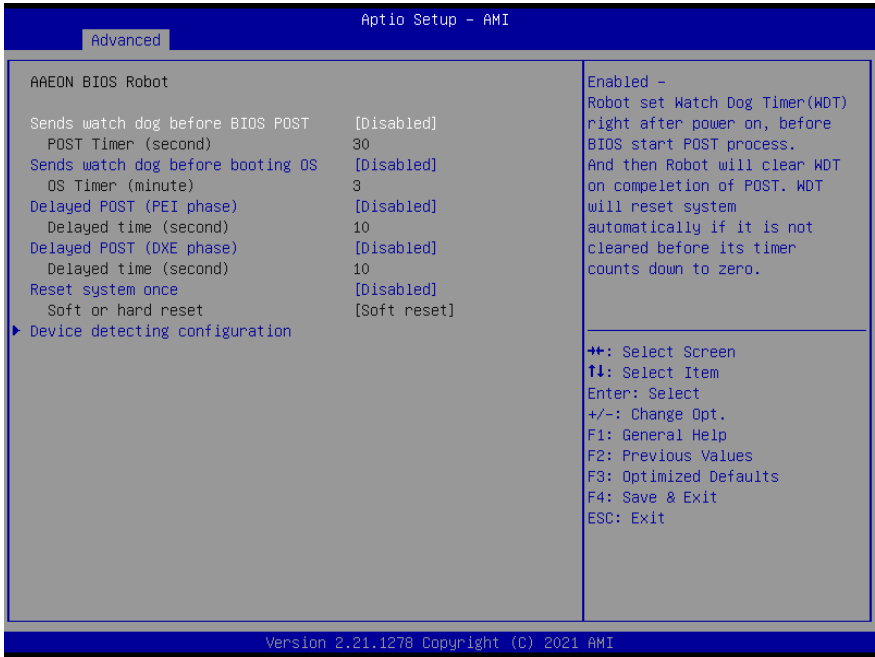

Options Summary		
Sends watch dog before BIOS POST	Disabled	Optimal Default, Failsafe Default
	Enabled	
Enabled - Robot set Watch Dog Timer (WDT) right after power on, before BIOS start POST process. And then Robot will clear WDT on completion of POST. WDT will reset system automatically if it is not cleared before its timer counts down to zero.		
POST Timer (second)	30	Optimal Default, Failsafe Default
Timer count set to Watch Dog Timer for POST. WARNING: Do not set to a value equal or shorter than normal POST time, otherwise system may never complete POST unless clearing BIOS settings. More than 2x normal POST time is suggested.		
Sends watch dog before booting OS	Disabled	Optimal Default, Failsafe Default
	Enabled	
Enabled - Robot set Watch Dog Timer (WDT) after POST completion, before BIOS transfer control to OS. WARNING: Before enabling this function, a program in OS must be in responsible for clearing WDT. Also, this function should be disabled if OS is going to update itself.		

Options Summary		
OS Timer (minute)	3	Optimal Default, Failsafe Default
Timer count set to Watch Dog Timer for OS loading.		
Delayed POST (PEI phase)	Disabled	Optimal Default, Failsafe Default
	Enabled	
Enabled - Robot holds BIOS from starting POST, right after power on. This allows BIOS POST to start with stable power or start after system is physically warmed-up. Note: Robot does this before 'Sends watch dog'.		
Delayed time (second)	10	Optimal Default, Failsafe Default
Period of time for Robot to hold BIOS from POST.		
Delayed POST (DXE phase)	Disabled	Optimal Default, Failsafe Default
	Enabled	
Enabled - Robot holds BIOS before POST completion. This allows BIOS POST to start with stable power or start after system is physically warmed-up. Note: Robot does this after 'Sends watch dog before BIOS POST'.		
Delayed time (second)	10	Optimal Default, Failsafe Default
Period of time for Robot to hold BIOS from POST.		
Reset system once	Disabled	Optimal Default, Failsafe Default
	Enabled	
Enabled - Robot resets system for one time on each boot. This will send a soft or hard reset to onboard devices, thus puts devices to more stable state.		
Soft or hard reset	Soft reset	Optimal Default, Failsafe Default
	Hard reset"	
Select reset type robot should send on each boot.		

3.4.12 Power Management

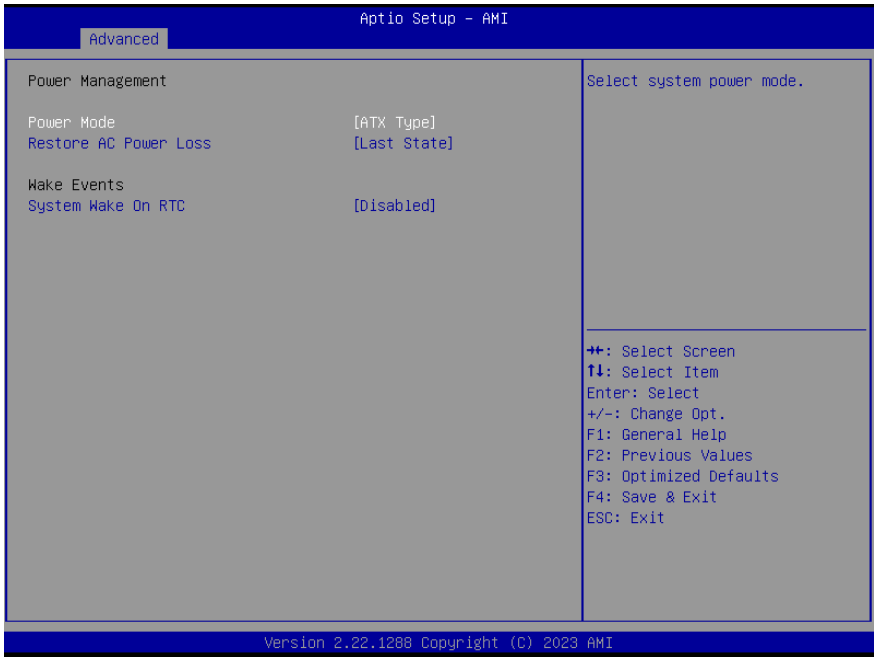

Options Summary		
Power Mode	ATX Type	Optimal Default, Failsafe Default
	AT Type	
Select power supply mode.		
Restore AC Power Loss	Last State	Optimal Default, Failsafe Default
	Always On	
	Always Off	
Select power state when power is re-applied after a power failure.		
System Wake On RTC	Disable	Optimal Default, Failsafe Default
	By Date	
	Bypass	
By Date: System will wake on the day with hr::min::sec specified./n By Weekday: System will wake on the enabled weekday with hr::min::sec specified./n Bypass: BIOS will not control RTC wake function.		

3.4.13 GPIO Port Configuration

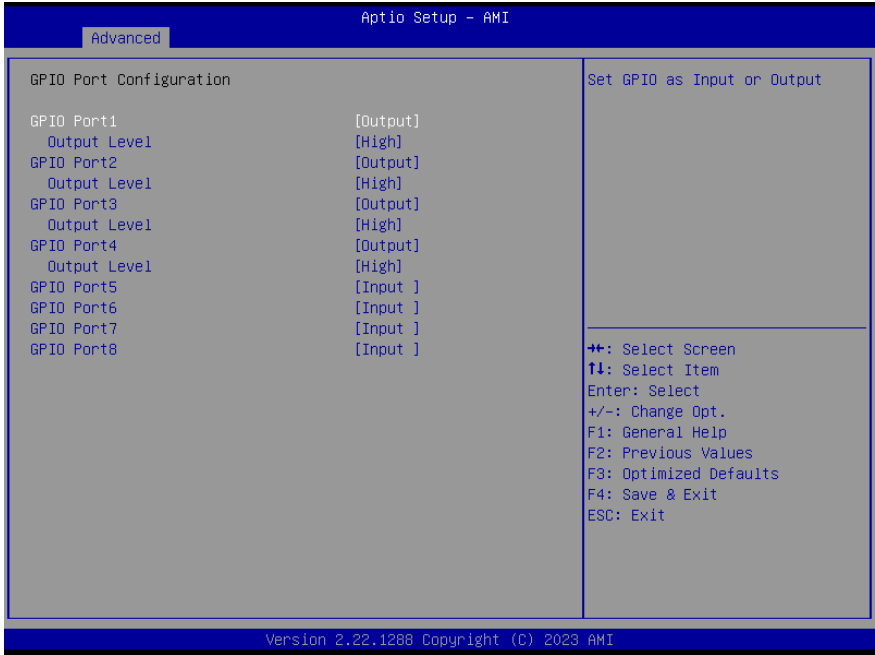

Options Summary		
GDIO Port*	Output	
	Input	
Set GPIO as Input or Output.		
Output Level	High	
	Low	
Set output level when GDIO pin is output.		

3.4.14 AAEON Smart Boost

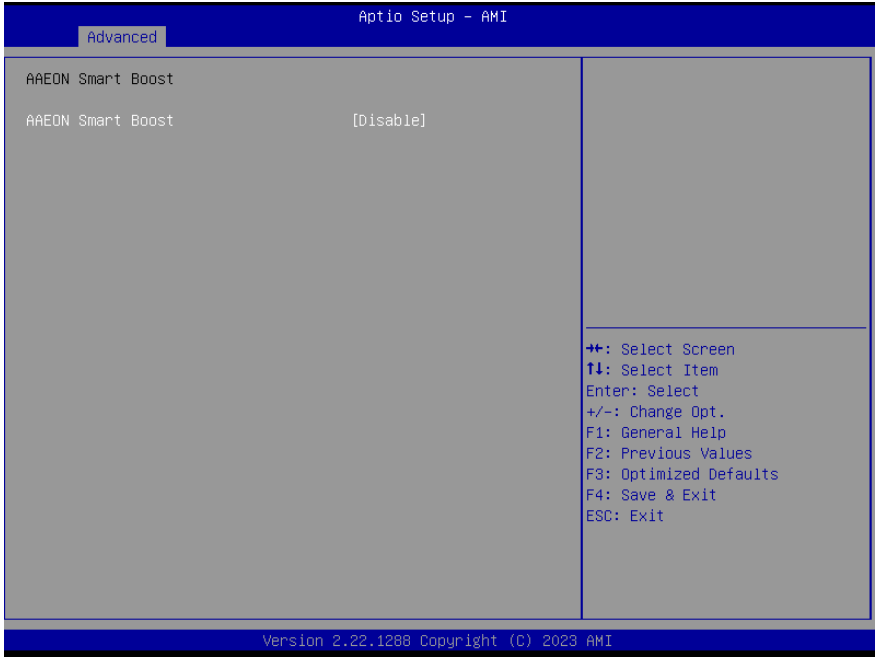

3.5 Setup Submenu: Chipset



3.5.1 System Agent (SA) Configuration



Options Summary		
VT-d	Disabled	Optimal Default, Failsafe Default
	Enabled	
VT-d capability.		

3.5.2 Memory Configuration



3.5.3 VMD Setup Menu



Options Summary		
Enable VMD Controller	Disabled	Optimal Default, Failsafe Default
	Enabled	
Enable/Disable to VMD Controller.		

3.5.4 PCH-IO Configuration



Options Summary		
HD Audio	Disabled	
	Enabled	Optimal Default, Failsafe Default
Control Detection of the HD-Audio Device. Disabled = HDA will unconditionally disabled. Enabled = HDA will be unconditionally enabled.		
PCH LAN Controller	Disabled	
	Enabled	Optimal Default, Failsafe Default
Enable/Disable onboard NIC.		

3.6 Setup Submenu: Security

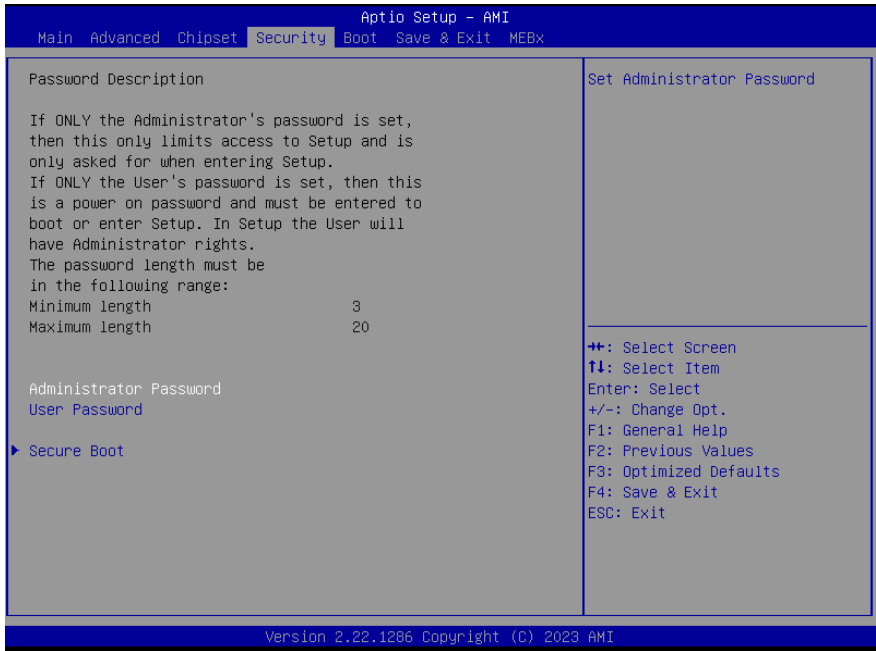

Change User/Supervisor Password

You can install a Supervisor password, and if you install a supervisor password, you can then install a user password. A user password does not provide access to many of the features in the Setup utility.

If you highlight these items and press Enter, a dialog box appears which lets you enter a password. You can enter no more than six letters or numbers. Press Enter after you have typed in the password. A second dialog box asks you to retype the password for confirmation. Press Enter after you have retyped it correctly. The password is required at boot time, or when the user enters the Setup utility.

Removing the Password

Highlight this item and type in the current password. At the next dialog box press Enter to disable password protection.

3.6.1 Secure Boot

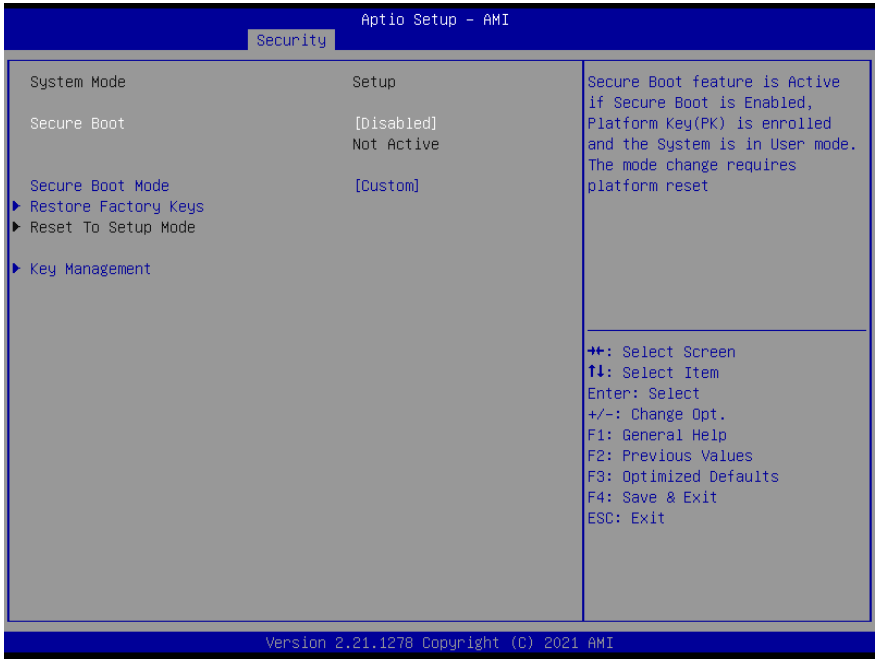

Options Summary		
Secure Boot	Disabled	Optimal Default, Failsafe Default
	Enabled	
Secure Boot feature is Active if Secure Boot is Enabled, Platform Key (PK) is enrolled and the System is in User mode. The mode change requires platform reset.		
Secure Boot Mode	Custom	Optimal Default, Failsafe Default
	Standard	
Secure Boot mode options: Standard or Custom. In Custom mode, Secure Boot Policy variables can be configured by a physically present user without full authentication.		
Restore Factory Keys		
Force System to User Mode. Install factory default Secure Boot key databases.		
Reset to Setup Mode		
Delete all Secure Boot key databases from NVRAM.		

3.6.2 Key Management

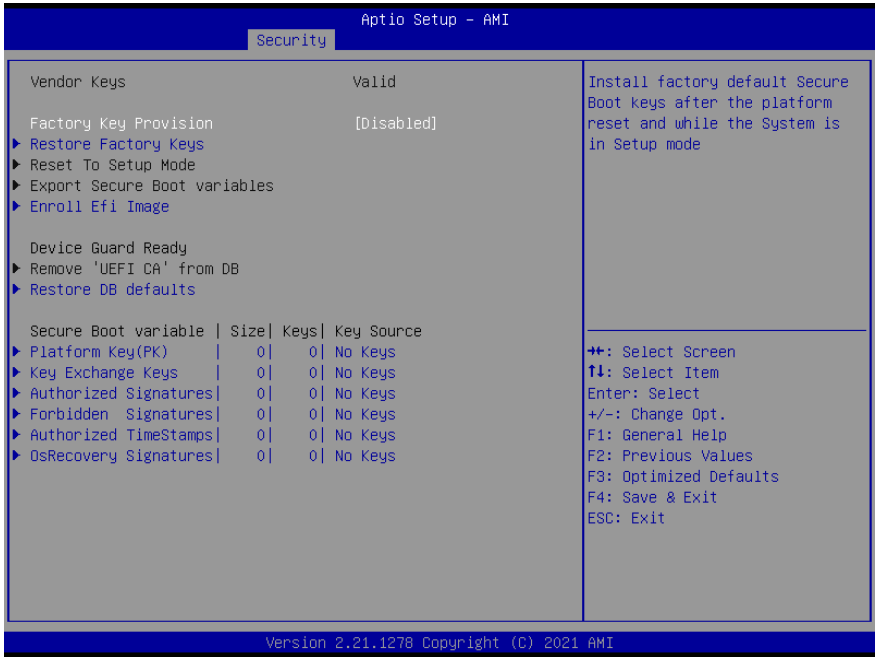

Options Summary		
Factory Key Provision	Disabled	Optimal Default, Failsafe Default
	Enabled	
Secure Boot feature is Active if Secure Boot is Enabled, Platform Key (PK) is enrolled and the System is in User mode. The mode change requires platform reset.		
Restore Factory Keys		
Force System to User Mode. Install factory default Secure Boot key databases.		
Reset to Setup Mode		
Delete all Secure Boot key databases from NVRAM.		
Export Secure Boot variables		
Copy NVRAM content of Secure Boot variables to files in a root folder on a file system device.		
Enroll Efi Image		
Allow the image to run in Secure Boot mode. Enroll SHA256 Hash certificate of a PE image into Authorized Signature Database (db).		
Remove 'UEFI CA' from DB		

Options Summary	
Device Guard ready system must not list 'Microsoft UEFI CA' Certificate in Authorized Signature database (db).	
Restore DB defaults	
Restore DB variable to factory defaults.	
Platform Key (PK)	Details
	Export
	Update
	Delete
Key Exchange Keys	Details
	Export
	Update
	Append
	Delete
Authorized Signatures	Details
	Export
	Update
	Append
	Delete
Forbidden Signatures	Details
	Export
	Update
	Append
	Delete
Authorized TimeStamps	Update
	Append
OsRecovery Signatures	Update
	Append
Enroll Factory Defaults or load certificates from a file:	
1. Public Key Certificate:	
a) EFI_SIGNATURE_LIST.	
b) EFI_CERT_X509 (DER).	
c) EFI_CERT_RSA2048 (bin).	
d) EFI_CERT_SHAXXX.	
2. Authenticated UEFI Variable.	
3. EFI PE/COFF Image (SHA256).	
Key Source: Factory, External, Mixed.	

3.7 Setup Submenu: Boot

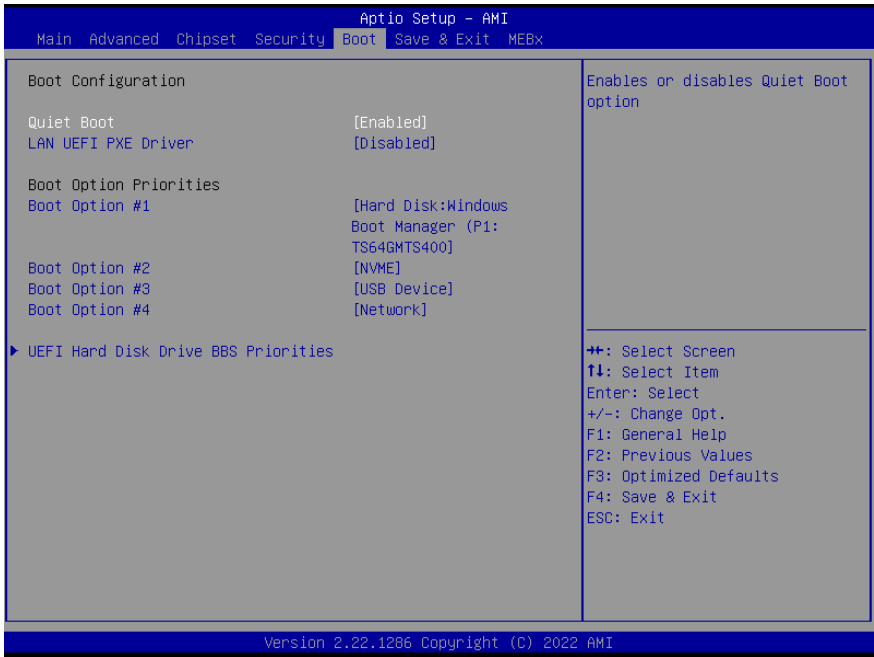

Options Summary		
Quiet Boot	Disabled	
	Enabled	Optimal Default, Failsafe Default
Enable or Disable Quiet Boot option.		
UEFI PXE Support	Disabled	Optimal Default, Failsafe Default
	Enabled	
Enable/Disable UEFI Network Stack.		
FIXED BOOT ORDER Priorities		
Sets the system boot order.		

3.8 Setup Submenu: Save & Exit

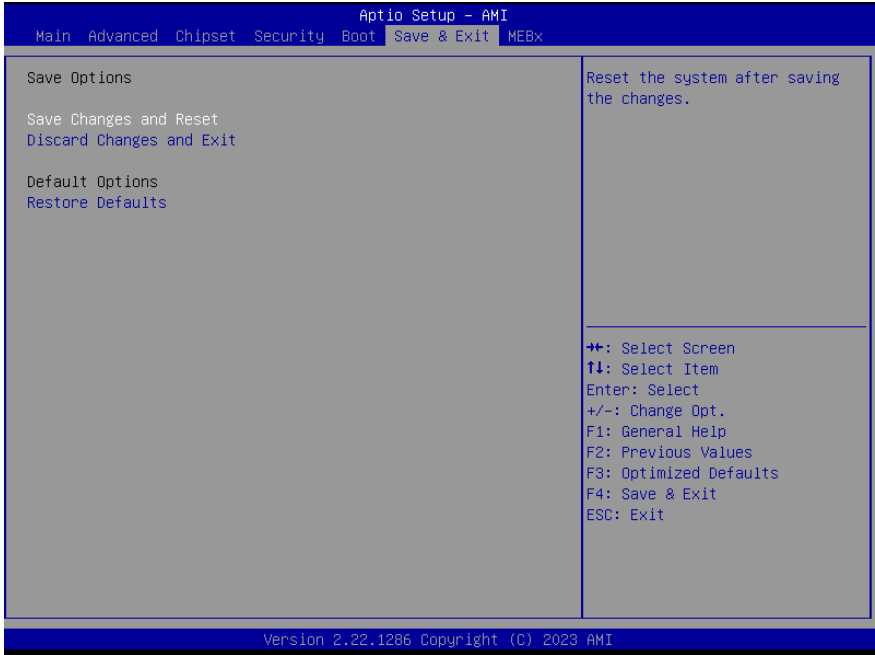

Options Summary	
Save Changes and Reset	Reset the system after saving the changes.
Discard Changes and Exit	Exit system setup without saving any changes.
Restore Defaults	Restore/Load Default values for all the setup options.

3.9 Setup Submenu: MEBx



3.9.1 Intel® AMT Configuration



Options Summary		
Password Policy	Default Password Only	
	During Setup and Configuration	
	Anytime	Optimal Default, Failsafe Default
Network Access State	Network Active	
	Network Inactive	Optimal Default, Failsafe Default
	Full Unprovision	
Changes network state of ME. When disabling, it will also clear some other settings.		

3.9.2 Redirection Features

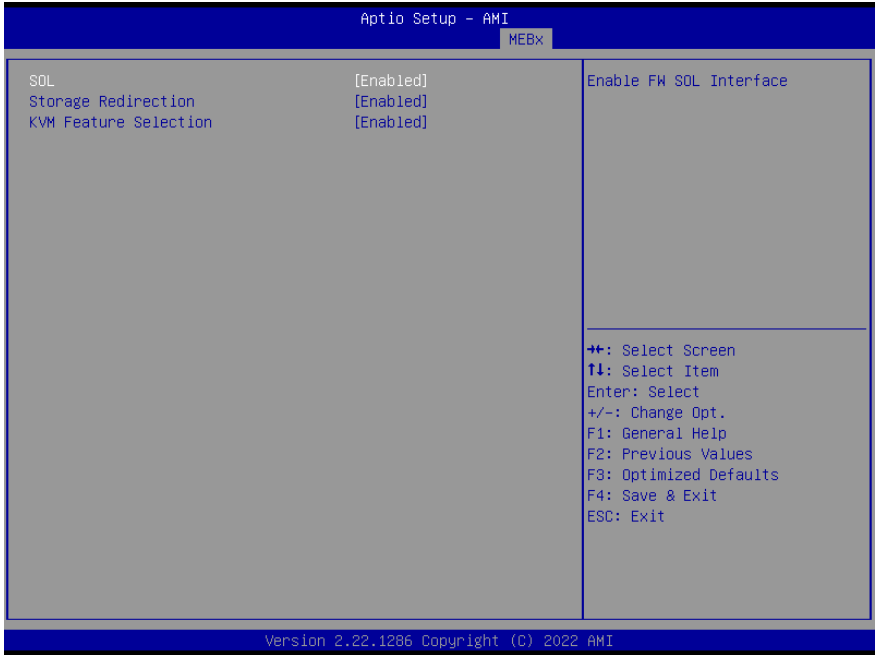

Options Summary		
SOL	Disabled	
	Enabled	Optimal Default, Failsafe Default
Enable FW SOL Interface.		
Storage Redirection	Disabled	
	Enabled	Optimal Default, Failsafe Default
Enable FW Remote – Storage Redirection.		
KVM Features Selection	Disabled	
	Enabled	Optimal Default, Failsafe Default
Enable FW KVM Feature.		

3.9.3 User Consent



Options Summary		
User Opt-in	None	
	KVM	Optimal Default, Failsafe Default
	ALL	
Configure When User Consent Should be Required.		
Opt-in Configurable from Remote IT	Disabled	
	Enabled	Optimal Default, Failsafe Default
Enable/Disable Remote Change Capability of User Consent Feature.		

3.9.4 Power Control

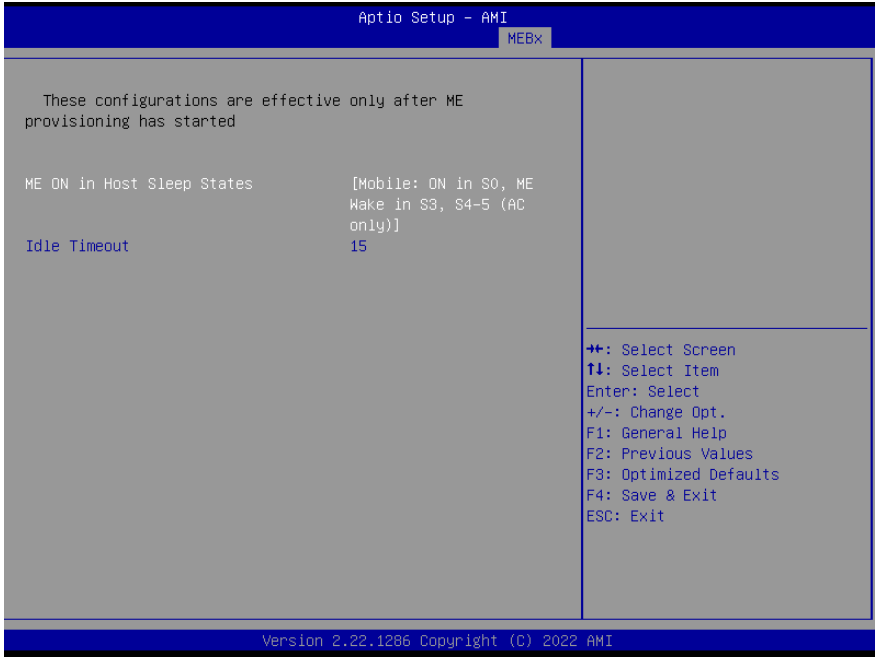

Options Summary		
ME ON in Host Sleep States	Mobile: ON in S0	Optimal Default, Failsafe Default
	Mobile: ON in S0, ME Wake in S3, S4-5(AC only)	
Idle Timeout	15	
Timeout Value (1-65536).		

Chapter 4

Drivers Installation

4.1 Drivers Download and Installation

Drivers for the EPIC-BTS9 can be downloaded from the product page on the AAEON website by following this link:

https://www.aaeon.com/en/product/detail/epic_boards_epic-bts9/download

Download the driver(s) you need and follow the steps below to install them.

Install Chipset Drivers

1. Open the **Chipset** folder
2. Open the **SetupChipset.exe** file
3. Follow the instructions
4. Drivers will be installed automatically

Install Graphics Driver

1. Open the **Graphics** folder
2. Open the **Installer.exe** file in the folder
3. Follow the instructions
4. Drivers will be installed automatically

Install LAN Drivers

Intel® Ethernet Connection 1219 for GbE LAN Port (CN46)

1. Open the folder where you unzipped the Intel® Ethernet Connection 1219 (ELD) Driver package.
2. Verify the following driver files are present:
 - **e1d.inf** – Setup Information
 - **e1d.sys** – System file
 - **e1dmsg.dll** – Application extension
 - **e1d.cat** – Security Catalog
3. Open Device Manager, then press **Windows + X**, then select **Device Manager** to locate the Ethernet Controller:
4. Right-click the Ethernet controller and select **Update driver**.
 - Choose **Browse my computer for drivers**.
 - Click **Browse**, then navigate to the folder containing **eld.inf**.
 - Click **Next** to install the driver.
5. Verify installation by confirming the Intel® Ethernet adapter appears under **Network adapters** with no warning icons.

Intel® Ethernet Controller I226 for 2.5GbE LAN Ports (CN45/CN48)

1. Open the folder where you unzipped the Intel® Ethernet Controller 1225 / 1226 (E2F) Driver package.
2. Verify the following driver files are present:
 - **e2f.inf** – Setup Information
 - **e2f.sys** – System file
 - **e2fmsg.dll** – Application extension
 - **e2f.cat** – Security Catalog
3. Open Device Manager, then press **Windows + X**, then select **Device Manager** to locate the Ethernet Controller:
4. Right-click the Ethernet controller and select **Update driver**.
 - Choose **Browse my computer for drivers**.
 - Click **Browse**, then navigate to the folder containing **eld.inf**.
 - Click **Next** to install the driver.
5. Verify installation by confirming the Intel® Ethernet adapter appears under **Network adapters** with no warning icons.

Install ME & TXE Drivers

1. Open the **ME & TXE Driver** folder
2. Open the **SetupME.exe** file
3. Follow the instructions
4. Drivers will be installed automatically

Install Serial I/O Driver

1. Open the **Serial I/O** folder
2. Verify the **.cat**, **.inf.**, and **.sys** driver files are present for each component:
 - a. **GPIO Driver**
 - b. **I2C Driver**
 - c. **SPI Driver**
 - d. **UART2 Driver**
 - e. **UART SubDevice Driver**
3. Press **Windows + X**, then select **Device Manager**, then locate the target device (devices may appear as **Unknown device**, **Serial I/O Controller**, etc.)
4. Install each driver
 - a. Right-click the target device and select Update driver.
 - b. Choose Browse my computer for drivers.
 - c. Click Browse, then navigate to the folder containing the .inf file for the component you want to install.

- d. Click **Next** to install the driver. by right-clicking the target device and selecting **Update driver**, then choose **browse my computer for drivers**, then navigate to the folder containing the **.inf** file for the component you want to install.
 - e. Click **Next** to install the driver.
5. Repeat step 4 for all Serial I/O components in the recommended order

Recommended Installation Order:

iaLPSS2_GPIO2 > iaLPSS2_I2C > iaLPSS2_SPI > iaLPSS2_UART2 > UartSubDevice

6. Verify installation by confirming the Intel® Ethernet adapter appears under **System devices** with no warning icons

Note: Do not manually open **.inf**, **.sys**, or **.cat** files. If a device appears as **Unknown device**, always use **Update driver** → **Browse my computer for drivers**.

Install RAID Driver

1. Open the **Intel® RST Driver** folder
2. Open the **SetupRST.exe** file
3. Follow the instructions
4. Drivers will be installed automatically

Install Audio Drivers

Note: Ensure Intel Smart Sound Driver (**ADSP-10.29.00.11525-MAIN-ProdFw**) is installed before the Realtek Audio driver (**Realtek Audio 6.0.9034.2**)

Install Intel Smart Sound Technology Driver

1. Open the **Intel Smart Sound Technology Driver** folder
2. Install Intel SST driver **IntcAudioBus.inf** and **IntcOED.inf**

Note: Make sure to install **IntcAudioBus.inf** before installing **IntcOED.inf**:

3. Installation steps using Device Manager:
 - Press **Windows + X** and select **Device Manager**.
 - Locate the device under **System devices** or **Other devices** (may appear as *Unknown device* or *Audio DSP*).
 - Right-click the device → **Update driver**.
 - Select **Browse my computer for drivers**.
 - Navigate to the folder containing **IntcAudioBus.inf**, then click **Next** to install.
 - Repeat the process for **IntcOED.inf**.

4. Verify installation by confirming the Intel® Ethernet adapter appears under **Network adapters** with no warning icons.

Install Realtek Audio Driver

1. Open the Intel Smart Sound Driver (**Realtek Audio 6.0.9034.2**) folder
2. Run the **Setup.exe** file in the folder
3. Follow the instructions
4. Driver will be installed automatically











































Install Linux Peripheral Drivers

1. Open the **Linux Driver-Peripheral** folder.
2. Follow the instructions provided in the **aaeon_wmi_all_V2.6.0.3.zip**. If you have any questions about the supported functions, please contact your regional FAE for more details.

Appendix A

I/O Information

A.1 I/O Address Map



▼		Input/output (IO)
		[0000000000000000 - 000000000000CF7] PCI Express Root Complex
		[0000000000000020 - 0000000000000021] Programmable interrupt controller
		[0000000000000024 - 0000000000000025] Programmable interrupt controller
		[0000000000000028 - 0000000000000029] Programmable interrupt controller
		[000000000000002C - 000000000000002D] Programmable interrupt controller
		[000000000000002E - 000000000000002F] Motherboard resources
		[0000000000000030 - 0000000000000031] Programmable interrupt controller
		[0000000000000034 - 0000000000000035] Programmable interrupt controller
		[0000000000000038 - 0000000000000039] Programmable interrupt controller
		[000000000000003C - 000000000000003D] Programmable interrupt controller
		[0000000000000040 - 0000000000000043] System timer
		[000000000000004E - 000000000000004F] Motherboard resources
		[0000000000000050 - 0000000000000053] System timer
		[0000000000000061 - 0000000000000061] Motherboard resources
		[0000000000000063 - 0000000000000063] Motherboard resources
		[0000000000000065 - 0000000000000065] Motherboard resources
		[0000000000000067 - 0000000000000067] Motherboard resources
		[0000000000000070 - 0000000000000070] Motherboard resources
		[0000000000000080 - 0000000000000080] Motherboard resources
		[0000000000000092 - 0000000000000092] Motherboard resources
		[00000000000000A0 - 00000000000000A1] Programmable interrupt controller
		[00000000000000A4 - 00000000000000A5] Programmable interrupt controller
		[00000000000000A8 - 00000000000000A9] Programmable interrupt controller
		[00000000000000AC - 00000000000000AD] Programmable interrupt controller
		[00000000000000B0 - 00000000000000B1] Programmable interrupt controller
		[00000000000000B2 - 00000000000000B3] Motherboard resources
		[00000000000000B4 - 00000000000000B5] Programmable interrupt controller
		[00000000000000B8 - 00000000000000B9] Programmable interrupt controller
		[00000000000000BC - 00000000000000BD] Programmable interrupt controller
		[0000000000002F8 - 0000000000002FF] Communications Port (COM2)
		[0000000000003F8 - 0000000000003FF] Communications Port (COM1)
		[0000000000004D0 - 0000000000004D1] Programmable interrupt controller
		[000000000000680 - 00000000000069F] Motherboard resources
		[000000000000A00 - 000000000000A0F] Motherboard resources
		[000000000000A10 - 000000000000A1F] Motherboard resources
		[000000000000A20 - 000000000000A2F] Motherboard resources
		[000000000000D00 - 000000000000FFFF] PCI Express Root Complex
		[00000000000164E - 00000000000164F] Motherboard resources
		[000000000001854 - 000000000001857] Motherboard resources
		[000000000002000 - 0000000000020FE] Motherboard resources
		[000000000003000 - 000000000003FFF] Intel(R) PCI Express Root Port #9 - 7AB0

[0000000000004000 - 0000000000004FFF] Intel(R) PCI Express Root Port #1 - 7AB8
[0000000000005000 - 000000000000503F] Intel(R) UHD Graphics 770
[0000000000005060 - 000000000000507F] Standard SATA AHCI Controller
[0000000000005080 - 0000000000005083] Standard SATA AHCI Controller
[0000000000005090 - 0000000000005097] Standard SATA AHCI Controller
[000000000000EFA0 - 000000000000EFBF] Intel(R) SMBus - 7AA3
[000000000000FFF8 - 000000000000FFFF] Intel(R) Active Management Technology - SOL (COM3)











































A.2 Memory Address Map











































Memory	
[0000000000A0000 - 0000000000BFFFF]	PCI Express Root Complex
[0000000080400000 - 0000000080DFFFF]	Intel(R) PCI Express Root Port #9 - 7AB0
[0000000080400000 - 00000000BFFFFFF]	PCI Express Root Complex
[0000000080E00000 - 00000000817FFFF]	Intel(R) PCI Express Root Port #1 - 7AB8
[0000000081800000 - 00000000819FFFF]	Intel(R) PCI Express Root Port #15 - 7AB6
[00000000818FC000 - 00000000818FFFF]	Intel(R) Ethernet Controller I226-LM #3
[0000000081900000 - 00000000819FFFF]	Intel(R) Ethernet Controller I226-LM #3
[0000000081A00000 - 0000000081AFFFF]	Intel(R) Ethernet Controller I226-LM
[0000000081A00000 - 0000000081BFFFF]	Intel(R) PCI Express Root Port #8 - 7ABF
[0000000081B00000 - 0000000081B03FFF]	Intel(R) Ethernet Controller I226-LM
[0000000081C00000 - 0000000081DFFFF]	Intel(R) PCI Express Root Port #4 - 7ABB
[0000000081CFC000 - 0000000081CFFFF]	Intel(R) Ethernet Controller I226-LM #2
[0000000081D00000 - 0000000081DFFFF]	Intel(R) Ethernet Controller I226-LM #2
[0000000081E00000 - 0000000081E03FFF]	Standard NVM Express Controller
[0000000081E00000 - 0000000081EFFFF]	Intel(R) PEG60 - 464D
[0000000081F00000 - 0000000081F1FFFF]	Intel(R) Ethernet Connection (17) I219-LM
[0000000081F20000 - 0000000081F21FFF]	Standard SATA AHCI Controller
[0000000081F22000 - 0000000081F227FF]	Standard SATA AHCI Controller
[0000000081F23000 - 0000000081F230FF]	Standard SATA AHCI Controller
[00000000BFFFFFF000 - 00000000BFFFFFFF]	Intel(R) Active Management Technology - SOL (COM3)
[00000000C0000000 - 00000000CFFFFFFF]	Motherboard resources
[00000000E0690000 - 00000000E069FFFF]	Intel(R) Serial IO GPIO Host Controller - INTC1056
[00000000E06A0000 - 00000000E06AFFFF]	Intel(R) Serial IO GPIO Host Controller - INTC1056
[00000000E06B0000 - 00000000E06BFFFF]	Intel(R) Serial IO GPIO Host Controller - INTC1056
[00000000E06D0000 - 00000000E06DFFFF]	Intel(R) Serial IO GPIO Host Controller - INTC1056
[00000000E06E0000 - 00000000E06EFFFF]	Intel(R) Serial IO GPIO Host Controller - INTC1056
[00000000FE010000 - 00000000FE010FFF]	Intel(R) SPI (flash) Controller - 7AA4
[00000000FED00000 - 00000000FED003FF]	High precision event timer
[00000000FED20000 - 00000000FED27FFF]	Motherboard resources
[00000000FED40000 - 00000000FED44FFF]	Trusted Platform Module 2.0
[00000000FED45000 - 00000000FED48FFF]	Motherboard resources
[00000000FED90000 - 00000000FED93FFF]	Motherboard resources
[00000000FEDA0000 - 00000000FEDA0FFF]	Motherboard resources
[00000000FEDA1000 - 00000000FEDA1FFF]	Motherboard resources
[00000000FEDC0000 - 00000000FEDC7FFF]	Motherboard resources
[00000000FEE00000 - 00000000FEE0FFFF]	Motherboard resources
[0000004000000000 - 0000004000000000]	Intel(R) UHD Graphics 770
[0000006000000000 - 0000006000000000]	Intel(R) UHD Graphics 770
[0000006001100000 - 0000006001100FFF]	Intel(R) USB 3.20 eXtensible Host Controller - 1.20 (Microsoft)
[0000006001118000 - 00000060011180FF]	Intel(R) SMBus - 7AA3
[00000077FFFEFA000 - 00000077FFFEFAFFF]	Intel(R) Management Engine Interface #1
[00000077FFFEFB000 - 00000077FFFEFBFFF]	Intel(R) Serial IO I2C Host Controller - 7ACC
[00000077FFFEFC000 - 00000077FFFEFCFFF]	Intel® Smart Sound Technology BUS
[00000077FFF000000 - 00000077FFF000000]	Intel® Smart Sound Technology BUS











































A.3 Large Memory Address

- ▼  Large Memory
 -  [0000004000000000 - 0000007FFFFFFFFF] PCI Express Root Complex
 -  ..

A.4 IRQ Mapping Chart

▼	 Interrupt request (IRQ)	
	 (ISA) 0x00000000 (00)	System timer
	 (ISA) 0x00000003 (03)	Communications Port (COM2)
	 (ISA) 0x00000004 (04)	Communications Port (COM1)
	 (ISA) 0x0000000E (14)	Intel(R) Serial IO GPIO Host Controller - INTC1056
	 (ISA) 0x00000037 (55)	Microsoft ACPI-Compliant System
	 (ISA) 0x00000038 (56)	Microsoft ACPI-Compliant System
	 (ISA) 0x00000039 (57)	Microsoft ACPI-Compliant System
	 (ISA) 0x0000003A (58)	Microsoft ACPI-Compliant System
	 (ISA) 0x0000003B (59)	Microsoft ACPI-Compliant System
	 (ISA) 0x0000003C (60)	Microsoft ACPI-Compliant System
	 (ISA) 0x0000003D (61)	Microsoft ACPI-Compliant System
	 (ISA) 0x0000003E (62)	Microsoft ACPI-Compliant System
	 (ISA) 0x0000003F (63)	Microsoft ACPI-Compliant System
	 (ISA) 0x00000040 (64)	Microsoft ACPI-Compliant System
	 (ISA) 0x00000041 (65)	Microsoft ACPI-Compliant System
	 (ISA) 0x00000042 (66)	Microsoft ACPI-Compliant System
	 (ISA) 0x00000043 (67)	Microsoft ACPI-Compliant System
	 (ISA) 0x00000044 (68)	Microsoft ACPI-Compliant System
	 (ISA) 0x00000045 (69)	Microsoft ACPI-Compliant System
	 (ISA) 0x00000046 (70)	Microsoft ACPI-Compliant System
	 (ISA) 0x00000047 (71)	Microsoft ACPI-Compliant System
	 (ISA) 0x00000048 (72)	Microsoft ACPI-Compliant System
	 (ISA) 0x00000049 (73)	Microsoft ACPI-Compliant System
	 (ISA) 0x0000004A (74)	Microsoft ACPI-Compliant System
	 (ISA) 0x0000004B (75)	Microsoft ACPI-Compliant System
	 (ISA) 0x0000004C (76)	Microsoft ACPI-Compliant System
	 (ISA) 0x0000004D (77)	Microsoft ACPI-Compliant System
	 (ISA) 0x0000004E (78)	Microsoft ACPI-Compliant System
	 (ISA) 0x0000004F (79)	Microsoft ACPI-Compliant System
	 (ISA) 0x00000050 (80)	Microsoft ACPI-Compliant System
	 (ISA) 0x00000051 (81)	Microsoft ACPI-Compliant System
	 (ISA) 0x00000052 (82)	Microsoft ACPI-Compliant System
	 (ISA) 0x00000053 (83)	Microsoft ACPI-Compliant System
	 (ISA) 0x00000054 (84)	Microsoft ACPI-Compliant System
	 (ISA) 0x00000055 (85)	Microsoft ACPI-Compliant System
	 (ISA) 0x00000056 (86)	Microsoft ACPI-Compliant System
	 (ISA) 0x00000057 (87)	Microsoft ACPI-Compliant System
	 (ISA) 0x00000058 (88)	Microsoft ACPI-Compliant System
	 (ISA) 0x00000059 (89)	Microsoft ACPI-Compliant System
	 (ISA) 0x0000005A (90)	Microsoft ACPI-Compliant System
	 (ISA) 0x0000005B (91)	Microsoft ACPI-Compliant System

 (ISA) 0x0000005C (92)	Microsoft ACPI-Compliant System
 (ISA) 0x0000005D (93)	Microsoft ACPI-Compliant System
 (ISA) 0x0000005E (94)	Microsoft ACPI-Compliant System
 (ISA) 0x0000005F (95)	Microsoft ACPI-Compliant System
 (ISA) 0x00000060 (96)	Microsoft ACPI-Compliant System
 (ISA) 0x00000061 (97)	Microsoft ACPI-Compliant System
 (ISA) 0x00000062 (98)	Microsoft ACPI-Compliant System
 (ISA) 0x00000063 (99)	Microsoft ACPI-Compliant System
 (ISA) 0x00000064 (100)	Microsoft ACPI-Compliant System
 (ISA) 0x00000065 (101)	Microsoft ACPI-Compliant System
 (ISA) 0x00000066 (102)	Microsoft ACPI-Compliant System
 (ISA) 0x00000067 (103)	Microsoft ACPI-Compliant System
 (ISA) 0x00000068 (104)	Microsoft ACPI-Compliant System
 (ISA) 0x00000069 (105)	Microsoft ACPI-Compliant System
 (ISA) 0x0000006A (106)	Microsoft ACPI-Compliant System
 (ISA) 0x0000006B (107)	Microsoft ACPI-Compliant System
 (ISA) 0x0000006C (108)	Microsoft ACPI-Compliant System
 (ISA) 0x0000006D (109)	Microsoft ACPI-Compliant System
 (ISA) 0x0000006D (109)	Trusted Platform Module 2.0
 (ISA) 0x0000006E (110)	Microsoft ACPI-Compliant System
 (ISA) 0x0000006F (111)	Microsoft ACPI-Compliant System
 (ISA) 0x00000070 (112)	Microsoft ACPI-Compliant System
 (ISA) 0x00000071 (113)	Microsoft ACPI-Compliant System
 (ISA) 0x00000072 (114)	Microsoft ACPI-Compliant System
 (ISA) 0x00000073 (115)	Microsoft ACPI-Compliant System
 (ISA) 0x00000074 (116)	Microsoft ACPI-Compliant System
 (ISA) 0x00000075 (117)	Microsoft ACPI-Compliant System
 (ISA) 0x00000076 (118)	Microsoft ACPI-Compliant System
 (ISA) 0x00000077 (119)	Microsoft ACPI-Compliant System
 (ISA) 0x00000078 (120)	Microsoft ACPI-Compliant System
 (ISA) 0x00000079 (121)	Microsoft ACPI-Compliant System
 (ISA) 0x0000007A (122)	Microsoft ACPI-Compliant System
 (ISA) 0x0000007B (123)	Microsoft ACPI-Compliant System
 (ISA) 0x0000007C (124)	Microsoft ACPI-Compliant System
 (ISA) 0x0000007D (125)	Microsoft ACPI-Compliant System
 (ISA) 0x0000007E (126)	Microsoft ACPI-Compliant System
 (ISA) 0x0000007F (127)	Microsoft ACPI-Compliant System
 (ISA) 0x00000080 (128)	Microsoft ACPI-Compliant System
 (ISA) 0x00000081 (129)	Microsoft ACPI-Compliant System
 (ISA) 0x00000082 (130)	Microsoft ACPI-Compliant System
 (ISA) 0x00000083 (131)	Microsoft ACPI-Compliant System
 (ISA) 0x00000084 (132)	Microsoft ACPI-Compliant System

	(ISA) 0x000001FF (511)	Microsoft ACPI-Compliant System
	(PCI) 0x00000013 (19)	Intel(R) Active Management Technology - SOL (COM3)
	(PCI) 0x0000001B (27)	Intel(R) Serial IO I2C Host Controller - 7ACC
	(PCI) 0xFFFFF7D7 (-41)	Intel(R) Management Engine Interface #1
	(PCI) 0xFFFFF7D8 (-40)	Intel® Smart Sound Technology BUS
	(PCI) 0xFFFFF7D9 (-39)	Intel(R) Ethernet Controller I226-LM #2
	(PCI) 0xFFFFF7DA (-38)	Intel(R) Ethernet Controller I226-LM #2
	(PCI) 0xFFFFF7DB (-37)	Intel(R) Ethernet Controller I226-LM #2
	(PCI) 0xFFFFF7DC (-36)	Intel(R) Ethernet Controller I226-LM #2
	(PCI) 0xFFFFF7DD (-35)	Intel(R) Ethernet Controller I226-LM #2
	(PCI) 0xFFFFF7DE (-34)	Intel(R) Ethernet Controller I226-LM #2
	(PCI) 0xFFFFF7DF (-33)	Intel(R) Ethernet Controller I226-LM #2
	(PCI) 0xFFFFF7E0 (-32)	Intel(R) Ethernet Controller I226-LM #3
	(PCI) 0xFFFFF7E1 (-31)	Intel(R) Ethernet Controller I226-LM #3
	(PCI) 0xFFFFF7E2 (-30)	Intel(R) Ethernet Controller I226-LM #3
	(PCI) 0xFFFFF7E3 (-29)	Intel(R) Ethernet Controller I226-LM #3
	(PCI) 0xFFFFF7E4 (-28)	Intel(R) Ethernet Controller I226-LM #3
	(PCI) 0xFFFFF7E5 (-27)	Intel(R) Ethernet Controller I226-LM #3
	(PCI) 0xFFFFF7E6 (-26)	Intel(R) Ethernet Controller I226-LM #3
	(PCI) 0xFFFFF7E7 (-25)	Intel(R) Ethernet Controller I226-LM
	(PCI) 0xFFFFF7E8 (-24)	Intel(R) Ethernet Controller I226-LM
	(PCI) 0xFFFFF7E9 (-23)	Intel(R) Ethernet Controller I226-LM
	(PCI) 0xFFFFF7EA (-22)	Intel(R) Ethernet Controller I226-LM
	(PCI) 0xFFFFF7EB (-21)	Intel(R) Ethernet Controller I226-LM
	(PCI) 0xFFFFF7EC (-20)	Intel(R) Ethernet Controller I226-LM
	(PCI) 0xFFFFF7ED (-19)	Intel(R) Ethernet Controller I226-LM
	(PCI) 0xFFFFF7EE (-18)	Intel(R) USB 3.20 eXtensible Host Controller - 1.20 (Microsoft)
	(PCI) 0xFFFFF7EF (-17)	Intel(R) UHD Graphics 770
	(PCI) 0xFFFFF7F0 (-16)	Intel(R) Ethernet Connection (17) I219-LM
	(PCI) 0xFFFFF7F1 (-15)	Standard NVM Express Controller
	(PCI) 0xFFFFF7F2 (-14)	Standard NVM Express Controller
	(PCI) 0xFFFFF7F3 (-13)	Standard NVM Express Controller
	(PCI) 0xFFFFF7F4 (-12)	Standard NVM Express Controller
	(PCI) 0xFFFFF7F5 (-11)	Standard NVM Express Controller
	(PCI) 0xFFFFF7F6 (-10)	Standard NVM Express Controller
	(PCI) 0xFFFFF7F7 (-9)	Standard NVM Express Controller
	(PCI) 0xFFFFF7F8 (-8)	Standard NVM Express Controller
	(PCI) 0xFFFFF7F9 (-7)	Standard NVM Express Controller
	(PCI) 0xFFFFF7FA (-6)	Standard NVM Express Controller
	(PCI) 0xFFFFF7FB (-5)	Standard NVM Express Controller
	(PCI) 0xFFFFF7FC (-4)	Standard NVM Express Controller
	(PCI) 0xFFFFF7FD (-3)	Standard NVM Express Controller

Appendix B

Mating Connectors

B.1 List of Mating Connectors and Cables

Label	Function	Mating Connector		Available Cable	Cable P/N
		Vendor	Model no		
CN1	External RTC Connector	Molex	51021-0200	Battery Cable	175011901C
CN2	SATA Connector	Molex	887505318	SATA Cable	170X000593
CN3	SATA Connector	Molex	887505318	SATA Cable	170X000593
CN5	Audio Connector	ACES	50247-012H0H0-001	Audio Cable	170X000156 170X000517
CN6/ CN34	SATA Power CONN	JST	PHR-2	2 Pins for HDD Power	1702150155
CN7	External +5VSB Power Input and PS_ON#	JST	XHP-3	ATX Cable for External +5VSB Power Input and PS_ON#	170220020B
CN13	USB Port Connector	ACES	50247-010H0H0-001	USB Wafer Cable	170010010D
CN14	COM1/2	JST	SHDR-20V-S-B	Serial Port Cable	170X000231
CN20	GPIO Connector	ACES	50247-010H0H0-001	N/A	N/A
CN21 /CN51	LAN LED	JST	SHR-4	LAN LED	170X000634
CN31	FPC Connector	SFT	AE-2S3059	FPC Cable	170X000441
CN33	TCC CONN	JST	SHR-3	TCC Cable	170X000505
CN35	CPU Fan Connector	Molex	470541000	N/A	N/A
CN40	VGA	Molex	510211300	VGA CABLE	170X000715 1709150151
CN42	3x2 DC Vin Connector	Molex	39-01-2065	3x2 DC in Power Cable	170X000823
CN52	Front Panel Connector	JST	SHR-10V-S-B	Front Panel	170X000603
CN56	Debug Connector	JST	SHR-10V-S-B	N/A	N/A
CN57	eDP Connector	KEL	SSL20-30S	eDP Cable	170X000313

Appendix C

3-Pin ATX Behavior Description

C.1 3-Pin ATX Behavior Description

For board level power design, the EPIC-BTS9 supports the 3-Pin ATX Power Scheme, and there are 3 scenarios.

Single Input Power Source – AT mode

Operate as “AT” mode, which the HW design supports “Auto Power Button: Enable”

Case 1:

When power supply or power adapter is “powered”, the system will boot up. Manually trigger PWRBTN# to turn off the computer. However, this only turns off the system, while the power source continues to supply power to the peripherals, such as cooler, SATA drive, USB ports, etc.

Case 2:

When power supply or power adapter is “powered”, the system will boot up. Manually turn off the power source directly to perform computer shut down. In this case, the system is turned off, and the power source will NOT supply power to the peripherals, meaning the whole system is shut down.

Single Input Power Source – ATX mode

Operating in “ATX mode”, wherein the H/W auto power button sets: disable, you must manually trigger the power button signal in order to power up or turn off the system. In this mode, when the power supply or power source is “powered”, manually trigger the power button signal to turn on or shut down the system. However, this only turns off the system, while the power source continues to supply power to the peripherals, such as cooler, SATA drive, USB ports, etc.

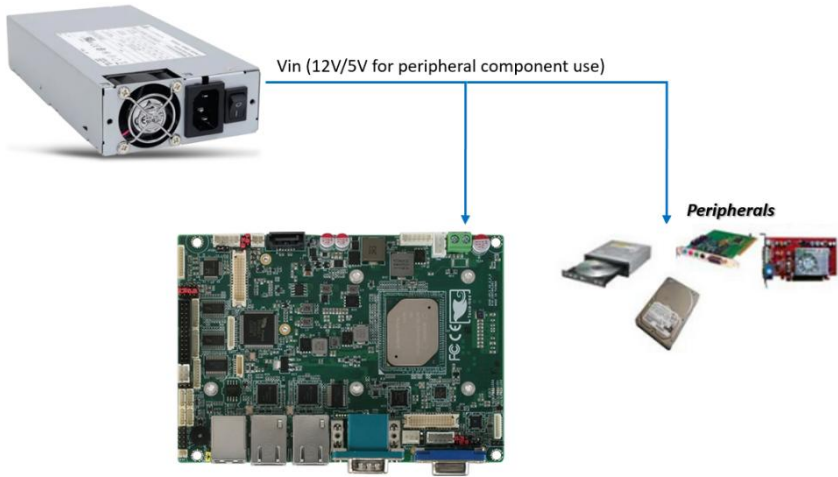

12V Input Power with 3-pin ATX External Connector

Operating in "ATX mode", manually triggering PWRBTN# is necessary to power up or shut down the system. All peripherals are powered by the S-rail powers, and S-rail powers (such as +12V and +5V), so they will power on or off with the power source.

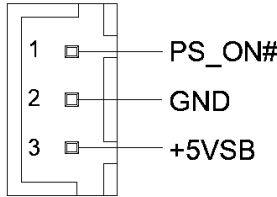

Pin	Pin Name	Signal Type	Signal Level
1	PS_ON#	OUT	+5V
2	GND	GND	-
3	+5VSB	PWR	+5V (2A)

The 3-pin ATX External Connector

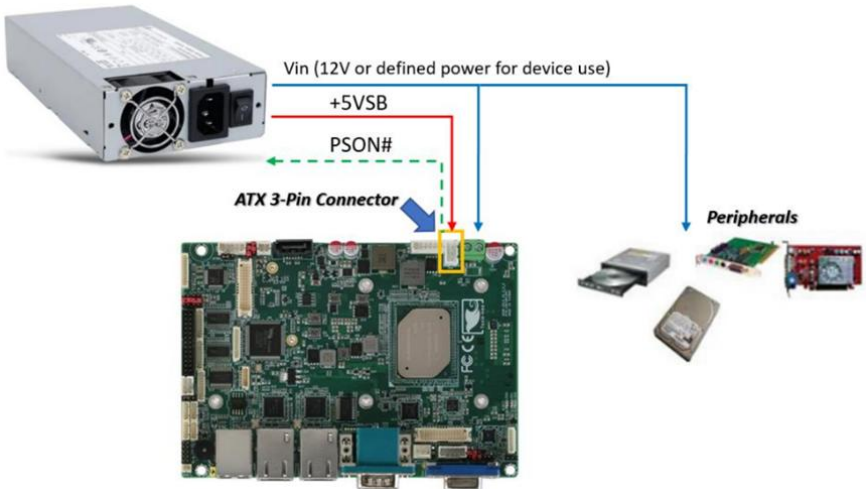

C.2 ATX Power Table

Type		Power Supply Unit / Turn On	Power Supply Unit / Turn Off
Single Input Power Source - AT Mode	SBC Mainboard	Powered	No Power
	External Peripherals	Powered	Powered
Single Input Power Source - ATX Mode	SBC Mainboard	Powered	No Power
	External Peripherals	Powered	Powered
12V Input Power with 3-pin ATX External Connector	SBC Mainboard	Powered	No Power
	External Peripherals	Powered	No Power