



HomeTek Technology Inc.

ADDRESS: No.85-5, Shir Men Road, Tu Cheng City,
Taipei Hsien, TAIWAN, R. O. C.

PHONE : 886-2-22608375 FAX : 886-2-22748013

E - mail : hometek@ms15.hinet.net

FCC TEST REPORT FOR

APPLICANT : Astech Technology CO., LTD.
ADDRESS : 6F-4, NO. 351, CHUNG-SHAN RD.,
SEC. 2, CHUNG-HO CITY, TAIPEI,
TAIWAN, R. O. C.
EUT : Industrial Workstation With 13.8" XGA Flat-Panel
Display
MODEL NO. : AMB-6501T
FCC ID : N/A

Under Part 15, SUBPART B.

CLASS A

PREPARED BY :

HomeTek Technology Inc.

No. 85-5, Shir Men Road, Tu Cheng City,

Taipei Hsien. TAIWAN, R. O. C.

Report # : FA8A007



HomeTek Technology Inc.

ADDRESS: No.85-5, Shir Men Road, Tu Cheng City,
Taipei Hsien, TAIWAN, R. O. C.

PHONE : 886-2-22608375 FAX : 886-2-22748013

E - mail : hometek@ms15.hinet.net

TEST REPORT CERTIFICATION

EUT : Industrial Workstation With 13.8" XGA Flat-Panel
Display

MODEL NO. : AMB-6501T

FCC ID : N/A

Final Test Date : 1/16/99 REPORT # : FA8A007

APPLICANT : Astech Technology CO., LTD.

ADDRESS : 6F-4, NO. 351, CHUNG-SHAN RD.,
SEC. 2, CHUNG-HO CITY, TAIPEI,
TAIWAN, R. O. C.

MEASUREMENT PROCEDURE USED :

PART 15 SUBPART B OF FCC RULES AND REGULATIONS
(47 CFR PART 15) FCC / ANSI C63.4-1992

WE HEREBY SHOW THAT :

THE MEASUREMENT SHOWN IN THE ATTACHMENT WERE MADE IN ACCORDANCE WITH THE PROCEDURES INDICATED, AND THE MAXIMUM ENERGY EMITTED BY THE EQUIPMENT WAS FOUND TO BE WITHIN THE FCC LIMITS APPLICABLE.

THIS TEST RESULTS OF THIS REPORT APPLIES TO ABOVE TESTED SAMPLE ONLY.

THIS TEST REPORT SHALL NOT BE REPRODUCE IN PART WITHOUT WRITTEN APPROVAL OF HOMETEK TECHNOLOGY INC.

PREPARED BY : Angel DATE : 1/19/99
ANGEL CHEN

CHECK BY : Joe DATE : 1/19/99
JOSEPH CHOU

APPROVED BY : Grant Huang DATE : 1/20/99
GRANT HUANG/Manager



TABLE OF CONTENTS

GENERAL INFORMATION..... 2

MODIFICATION LIST..... 4

CONDUCTED POWER LINE TEST..... 5

 1 TEST INSTRUMENTS & FACILITIES..... 5

 2 TEST PROCEDURE..... 5

 3 TEST SETUP 6

 4 CONFIGURATION OF THE EUT..... 8

 5 EUT OPERATING CONDITION..... 11

 6 LIMIT OF CONDUCTED POWER LINE EMISSION CLASS A:..... 11

 7 RESULT OF CONDUCTED POWER LINE TEST (1)..... 12

 8 PHOTO OF CONDUCTED POWER LINE TEST 13

 9 RESULT OF CONDUCTED POWER LINE TEST (2)..... 14

 10 PHOTO OF CONDUCTED POWER LINE TEST 15

RADIATED EMISSION TEST..... 16

 1 TEST INSTRUMENTS & FACILITIES..... 16

 2 TEST PROCEDURE..... 17

 3 TEST SETUP 17

 4 CONFIGURATION OF THE EUT 19

 5 EUT OPERATING CONDITION..... 19

 6 LIMIT OF RADIATED EMISSION CLASS A:..... 19

 7 RESULT OF RADIATED EMISSION TEST (1)..... 20

 8 PHOTO OF RADIATED EMISSION TEST 22

 9 RESULT OF RADIATED EMISSION TEST (2)..... 23

 10 PHOTO OF RADIATED EMISSION TEST 25

SAMPLE OF FCC LABEL 26

PHOTOS OF EUT..... 27



GENERAL INFORMATION

- 1 APPLICANT : Astech Technology CO., LTD.
- 2 ADDRESS : 6F-4, NO. 351, CHUNG-SHAN RD.,
SEC. 2, CHUNG-HO CITY, TAIPEI,
TAIWAN, R. O. C.

- 3 MANUFACTURER : Astech Technology CO., LTD.
- 4 ADDRESS : 6F-4, NO. 351, CHUNG-SHAN RD.,
SEC. 2, CHUNG-HO CITY, TAIPEI,
TAIWAN, R. O. C.

- 5 DESCRIPTION OF EUT :
 - EUT : Industrial Workstation With 13.8" XGA Flat-Panel Display
 - FCC ID : N/A
 - Model Number : AMB-6501T
 - Serial # : N/A
 - Data Cable : SHIELDED
 - Power Cord : UN-SHIELDED
 - Power Supply Type : SWITCHING

6 FEATURES OF EUT :

- 6.1 NEMA 4/12 painted aluminum alloy front panel
- 6.2 13.8" XGA color TFT LCD display
- 6.3 EIA RS-310C 19" rackmount, 8U height
- 6.4 Two sealed membrane keyboards (59 data-entry key and 24 function-key)
- 6.5 Two-screw-on door on the front panel covering the brightness and contrast controllers, power switch, slot for a 3.5" FDD, a 5.25" FDD or CD-ROM drive and keyboard connector
- 6.6 Disk drive housing: a 3.5" FDD and 3.5" HDD, a 5.25" FDD or CD-ROM driver
- 6.7 64 CFM cooling fan
- 6.8 Hold-down clamp protecting cards from vibration
- 6.9 Universal 250W switching power supply or other options
(refer to the selection table)

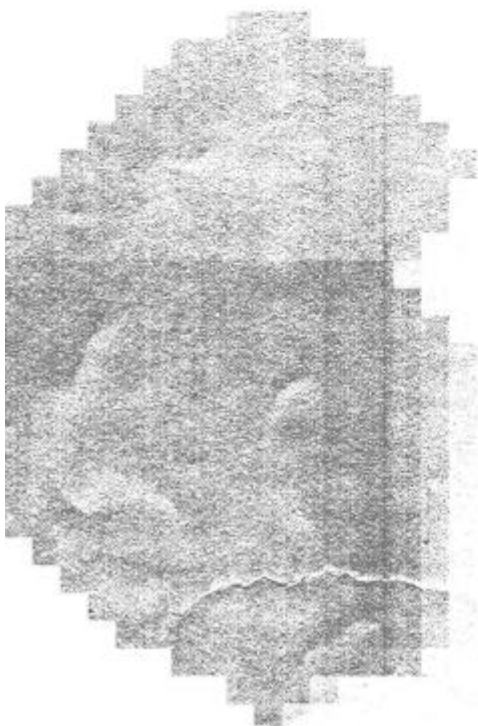



HomeTek Technology Inc.

MODIFICATION LIST

THE FOLLOWING ACCESSORIES WERE ADDED TO THE EUT DURING TESTING :

NO MODIFICATION BY HOMETEK TECHNOLOGY INC.

CONDUCTED POWER LINE TEST

1 TEST INSTRUMENTS & FACILITIES

The following test Instruments was used during the conducted test :

Item	Instruments/ Facilities	Specification	Manufacturer	Model # / S/N#	Date Of Cal.
1	EMI Receiver	9KHz ~ 30MHz	ROHDE & SCHWARZ	ESHS 30 844827/007	FEB/98
2	LISN	50 Ω /50uH/100A 9KHz ~ 30MHz	SCHWARZ BECK	NNLK 8121 8121370	FEB/98
3	LISN	9KHz ~ 30MHz	ROHDE & SCHWARZ	ESH3-Z5 846128/007	FEB/98
4	Pulse Limiter	9KHz ~ 30MHz	ROHDE & SCHWARZ	ESH3Z2 357.8810.52	JUL/98

Note : All equipment upon which need to calibrated are with period of 1 year.

2 TEST PROCEDURE

- 2.1 The EUT was tested according to **ANSI C63.4 - 1992**.
- 2.2 The EUT was placed 0.4 meter from the conducting wall of shielding room and kept at least 0.8 meter from any other grounded conducting surface.
- 2.3 The frequency range form 0.45 MHz to 30 MHz was investigated.
- 2.4 The LISN used was 50 Ohm / 50 uHenry as specified by Section 5.1 of **ANSI C63.4 - 1992**.
- 2.5 All the support peripherals are connect to the other LISN.
- 2.6 Cables and peripherals were moved to find the maximum emission levels for each frequency.

3 TEST SETUP

3.1 Typical : Setup Of Conducted Test

ELECTRICAL AND ELECTRONIC EQUIPMENT IN THE RANGE OF 9kHz TO 40 GHz ANSI C63.4-1992

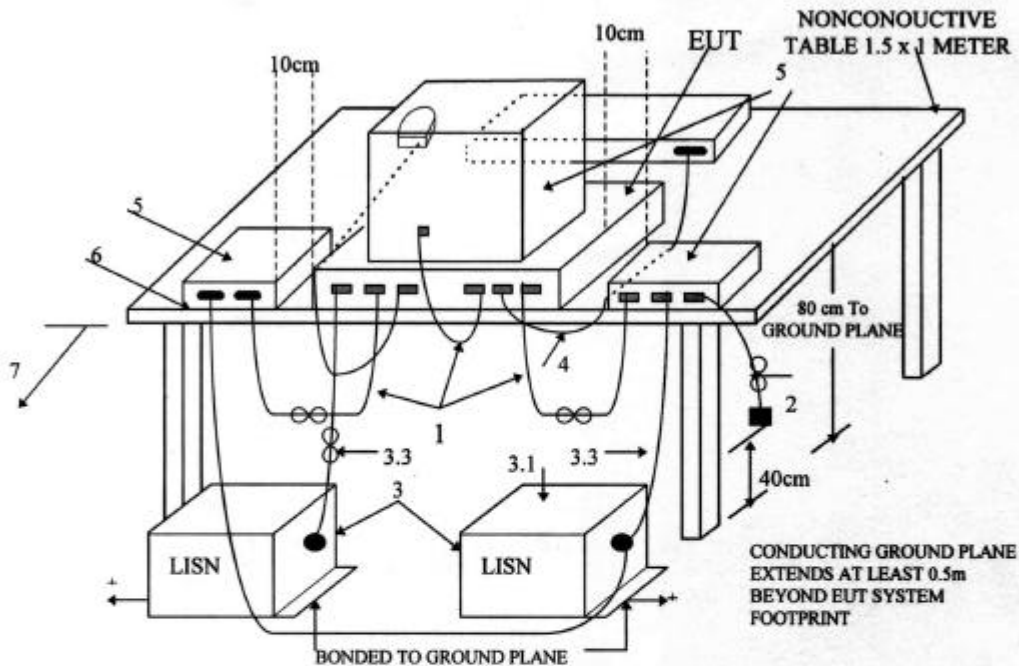

+LISNs may have to be moved to the side to meet 3.3 below.

LEGEND:

1. Interconnecting cables that hang closer than 40 cm to the ground plane shall be folded back and forth forming a bundle 30 to 40 cm long, hanging approximately in the middle between ground plane and table.
2. I/O cables that are connected to a peripheral shall be bundled in center. The end of the cable may be terminated if required using correct terminating impedance. The total length shall not exceed 1m.
3. EUT connected to one LISN. Unused LISN connectors shall be terminated in 50 Ω. LISN can be placed on top of, or immediately beneath, ground plane.
 - 3.1 All other equipment powered from second LISN.
 - 3.2 Multiple outlet strip can be used for multiple power cords of non-EUT equipment.
 - 3.3 LISN at least 80 cm from nearest part of EUT chassis.
4. Cables of hand-operated devices, such as keyboards, mice, etc., have to be placed as close as possible to the host.
5. Non-EUT components being tested.
6. Rear of EUT, including peripherals, shall be all aligned and flush with rear of tabletop.
7. Rear of tabletop shall be 40 cm removed from a vertical conducting plane that is bonded to the floor ground plane (see 5.2).

**Test Configuration
Tabletop Equipment Conducted Emission**

3.2 Block Diagram Of Conducted Test

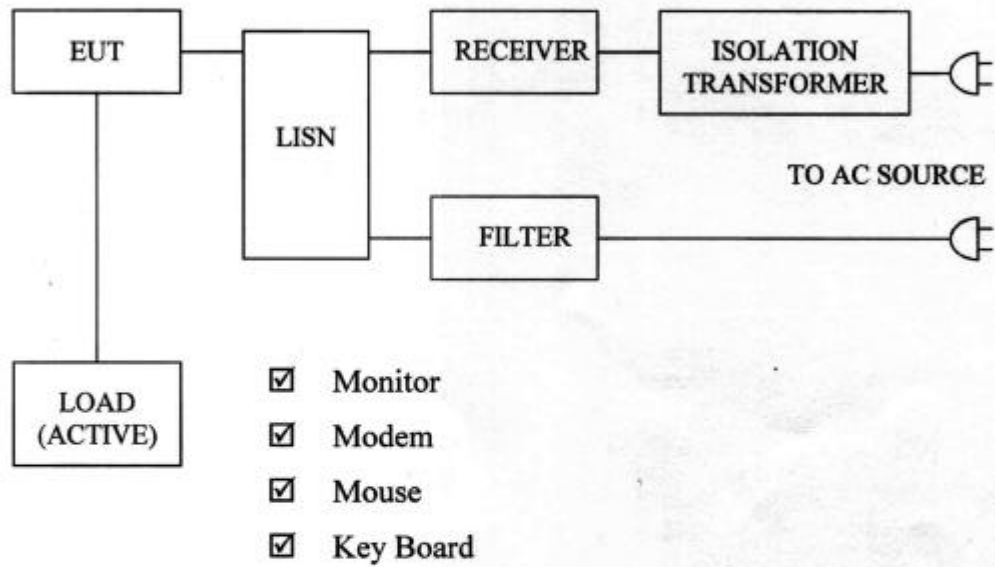

4 CONFIGURATION OF THE EUT

The EUT was configured according to ANSI C63.4 - 1992. All I/O ports were connected to the appropriate peripherals. All peripherals and cables are listed below (including internal device) :

4.1 EUT

EUT Type : Proto Type Engineer Type Mass Production
Condition when received : Good Damage : _____
Connector Type : Metal Type Plastic Type
Device : Industrial Workstation With 13.8" XGA Flat-Panel Display
Manufacturer : Astech
Model Number : AMB-6501T
Serial Number : N/A
FCC ID : N/A
Data Cable : Shielded
Power Cord : Un-Shielded, 1.8 m

4.2 PERIPHERALS

Monitor
Manufacturer : HITACHI
Model Number : CM1711MU
Serial Number : 95092015
FCC ID : KRY9501CDTC95
Data Cable : Shielded, 1.5 m, Connected to the VGA port
Power Cord : Un-Shielded, 1.8 m



Modem I

Manufacturer : DATATRONIC
Model Number : 2814CX
Serial Number : 1150541132
FCC ID : FCC DoC
Data Cable : Shielded, 1.5m, Connected to the COM port
Power Cord & Adaptor : Un-Shielded, 1.8 m

Modem II

Manufacturer : DATATRONIC
Model Number : 2814CX
Serial Number : 1150541132
FCC ID : FCC DoC
Data Cable : Shielded, 1.5m, Connected to the COM port
Power Cord & Adaptor : Un-Shielded, 1.8 m

Mouse (PSII)

Manufacturer : HP
Model Number : M-S34
Serial Number : LZA64519290
FCC ID : DZL211029
Data Cable : Shielded, 1.8m, Connected to the PSII port
Power Cord : N/A



KeyBoard (PSII)

Manufacturer : AST
Model Number : SK-2000REW
Serial Number : S950800011
FCC ID : GYUR26SK
Data Cable : Shielded, 1.5m, Connected to the PSII port
Power Cord : N/A

KeyBoard (PSII)

Manufacturer : SILITEK
Model Number : SK-2300
Serial Number : N/A
FCC ID : GYUR53SK
Data Cable : Shielded, 1.5m, Connected to the PSII port
Power Cord : N/A

4.3 Internal Devices

CPU CARD

Manufacturer : Astech
Model Number : PSC6X86
Serial Number : N/A
FCC ID : N/A
Data Cable : N/A
Power Cord : N/A

4.4 REMARK :



5 EUT OPERATING CONDITION

- 5.1 Operating condition is according to **ANSI C63.4 - 1992.**
- 5.2 AMD K6 - 233 MHz
CPU Clock : 66 MHz
- 5.3 Turn on the power of all equipments.
- 5.4 Test program sent "H" pattern to peripherals as following :
 - 5.4.1 Monitor
 - 5.4.2 Modem
 - 5.4.3 Keyboard

6 LIMIT OF CONDUCTED POWER LINE EMISSION CLASS A:

Frequency Range	dBuV	uV
0.45 ~ 1.705 MHz	60.0	1000 uV
1.705 ~ 30 MHz	69.5	3000 uV

- 6.1 In the above table, the tighter limit applies at the band edges.

7 RESULT OF CONDUCTED POWER LINE TEST (1)

7.1 The frequency range from 0.45 MHz to 30 MHz was investigated. All readings are quasi-peak values.

7.2 IF bandwidth : 9 kHz, Meas Time : 1 sec.

7.3 Temperature : 21 °C, Humidity : 72 % RH.

7.4 Deviations from the specifications : None

7.5 Quasi-Peak :

Frequency (MHz)	Line 1		Line 2		Limit	
	dBuV	uV	dBuV	uV	dBuV	uV
0.450	28.73	27.32	29.52	29.92	60.0	1000
0.870	25.55	18.95	24.96	17.70	60.0	1000
1.955	27.22	22.96	27.38	23.39	69.5	3000
3.530	26.43	20.97	27.00	22.39	69.5	3000
5.420	24.11	16.05	23.88	15.63	69.5	3000
9.260	33.01	44.72	37.18	72.28	69.5	3000
16.320	19.12	9.04	28.72	27.29	69.5	3000
24.640	33.48	47.21	35.90	62.37	69.5	3000

REMARK :

1. Model : AMB-6501T
2. Measuring mode : 1024 x 768
3. Uncertainty in conduction emission measured : $< \pm 2.0\text{dB}$.
4. “ * ”, means this data is worse case emission level.
5. Result : **PASSED**

8 PHOTO OF CONDUCTED POWER LINE TEST
Test Mode : 1024 x 768



Front View

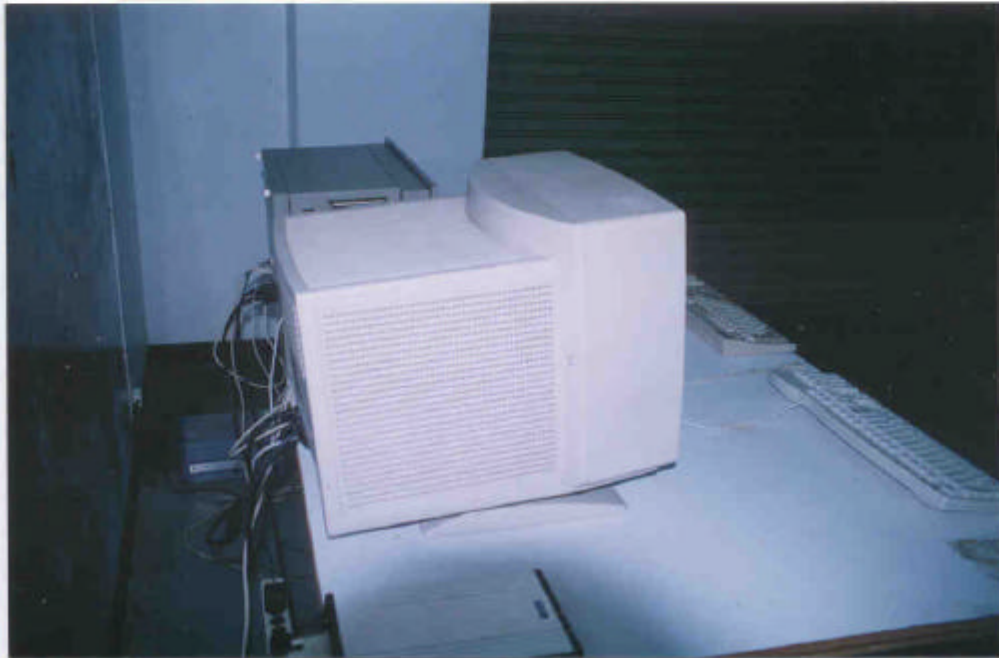

Rear View

9 RESULT OF CONDUCTED POWER LINE TEST (2)

9.1 The frequency range from 0.45 MHz to 30 MHz was investigated. All readings are quasi-peak values.

9.2 IF bandwidth : 9 kHz, Meas Time : 1 sec.

9.3 Temperature : 21 °C, Humidity : 72 % RH.

9.4 Deviations from the specifications : None

9.5 Quasi-Peak :

Frequency (MHz)	Line 1		Line 2		Limit	
	dBuV	uV	dBuV	uV	dBuV	uV
0.450	29.05	28.35	29.36	29.38	60.0	1000
0.870	26.20	20.42	25.49	18.81	60.0	1000
1.325	27.40	23.44	27.30	23.17	60.0	1000
2.270	21.69	12.15	23.78	15.45	69.5	3000
3.845	24.86	17.50	26.68	21.58	69.5	3000
9.260	32.95	44.41	37.75	77.18	69.5	3000
17.760	20.14	10.16	29.40	29.51	69.5	3000
24.640	33.32	46.34	36.12	63.97	69.5	3000

REMARK :

1. Model : AMB-6501T
2. Measuring mode : 640 x 480
3. Uncertainty in conduction emission measured : < ± 2.0dB.
4. “ * ”, means this data is worse case emission level.
5. Result : **PASSED**

10 PHOTO OF CONDUCTED POWER LINE TEST

Test Mode : 640 x 480



Front View

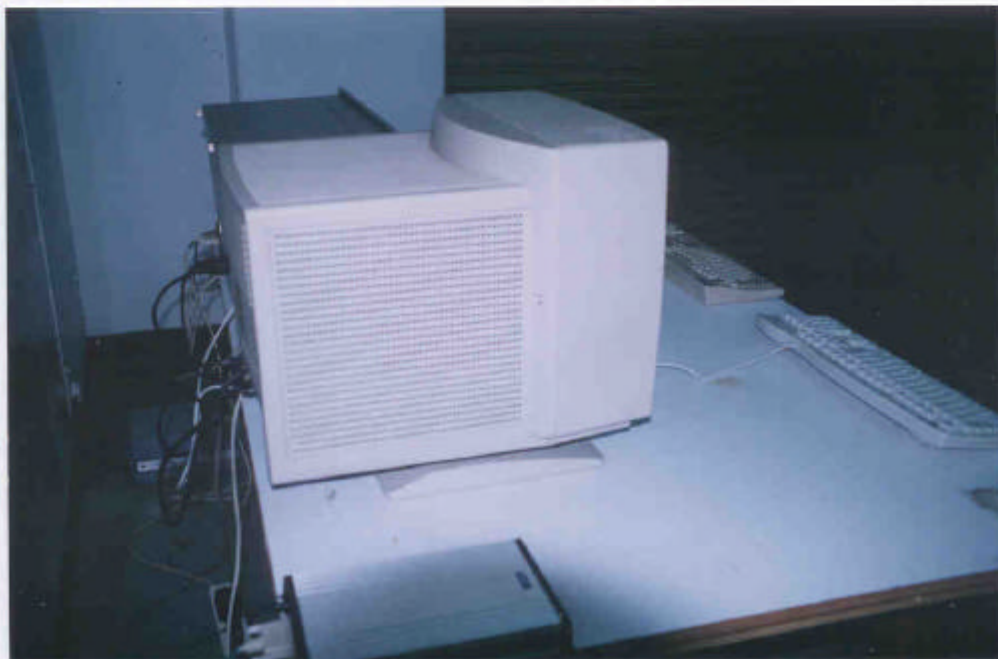

Rear View

RADIATED EMISSION TEST

1 TEST INSTRUMENTS & FACILITIES

The following test Instruments was used during the radiated emission test :

Item	Instruments /facilities	Specification	Manufacturer	Model # / S/N#	Location	Date of Cal.
1	OPEN AREA TEST SITE	<input type="checkbox"/> OATS 1 <input checked="" type="checkbox"/> OATS 2				JUN/98 JUN/98
2	SPECTRUM ANALYZER	9KHz ~ 1.8GHz	HP	HP8591 3710A06158	Open Site I	APR/98
3	EMI TEST RECEIVER	20MHz ~ 1GHz	ROHDE & SCHWARZ	ESVS10 845165/017	Open Site I	FEB/98
4	PRE-AMPLIFIER	0.1MHz ~ 1.3 GHz	HP	8447D 1937A02095	Open Site I	MAY/98
5	EMI TEST RECEIVER	20Hz ~ 26.5GHz	ROHDE & SCHWARZ	ESMI 845442/006	Open Site II	FEB/98
6	PRE-AMPLIFIER	20MHz ~ 7GHz	ROHDE & SCHWARZ	ESMI-Z7 846363/001	Open Site II	FEB/98
7	ANTENNA (BI-LOG)	25MHz ~ 2GHz	ARA	LPB2520 S/N:1096	Open Site II	MAR/98
8	ANTENNA (BI-LOG)	25MHz ~ 2GHz	ARA	LPB2520 S/N:1095	Open Site I	MAR/98
9	CABLES	30MHz ~ 1GHz		No. 2, No. 4 No. 1, No. 3	OATS 1 OATS 2	JUL/98 JUL/98
10	ANTENNA (DIPOLE)	30 ~ 300MHz	ROHDE & SCHWARZ	HZ-12 842899/08		JAN/99
11	ANTENNA (DIPOLE)	300 ~ 1000MHz	ROHDE & SCHWARZ	HZ-13 842007/0004		JAN/99
12	EMIVM	30 ~ 1000MHz	AUDIX	A582445 A582443	OATS 1 OATS 2	N/A

Note : 1. Items 1 ~ 9 upon which need to calibrated are with period of 1 year, except item 10-11.

2. Items 5 is used for the final measurement.

2 TEST PROCEDURE

- 2.1 The EUT was test according to ANSI C63.4 - 1992.
- 2.2 The radiated test was performed at HomeTek Lab's Open Site II.
- 2.3 This site is on file with the FCC laboratory division, reference 31040/site 1300F2, Date : August 22, 1997.
- 2.4 The frequency range from 30 MHz to 1 GHz, the measurement were made at 10 meters, with a BI-log antenna.

3 TEST SETUP

3.1 TEST SETUP OF OPEN SITE.

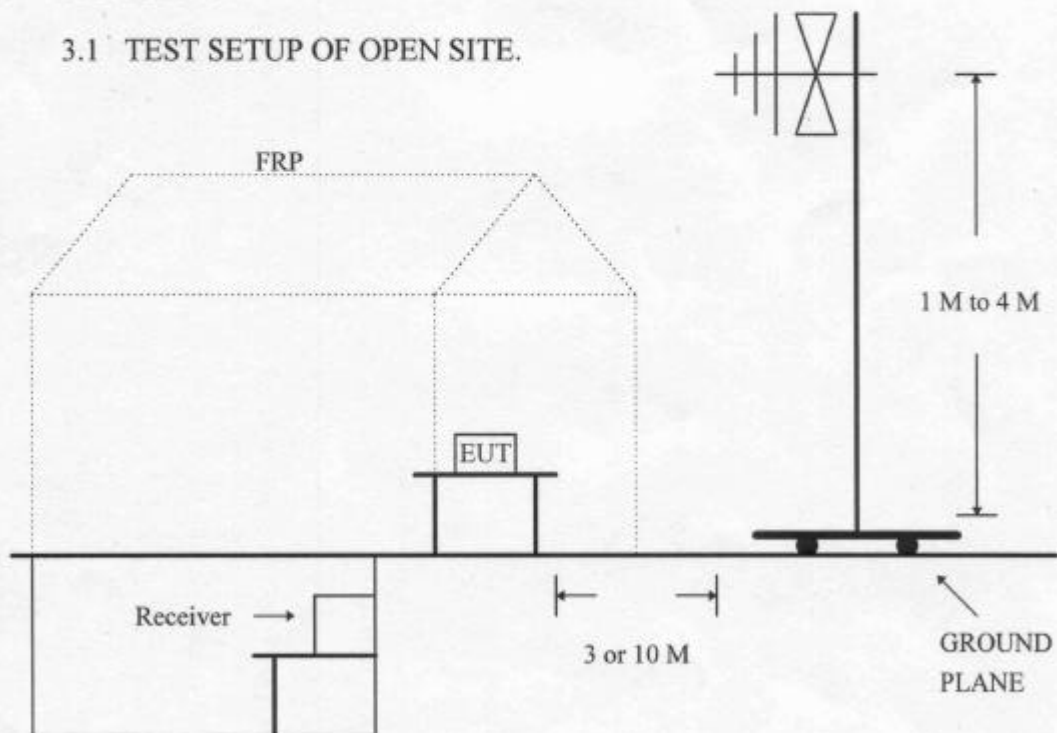

3.2 TEST SET OF EUT

ELECTRICAL AND ELECTRONIC EQUIPMENT IN THE RANGE OF 9kHz TO 40 GHz

ANSI
C63.4-1992

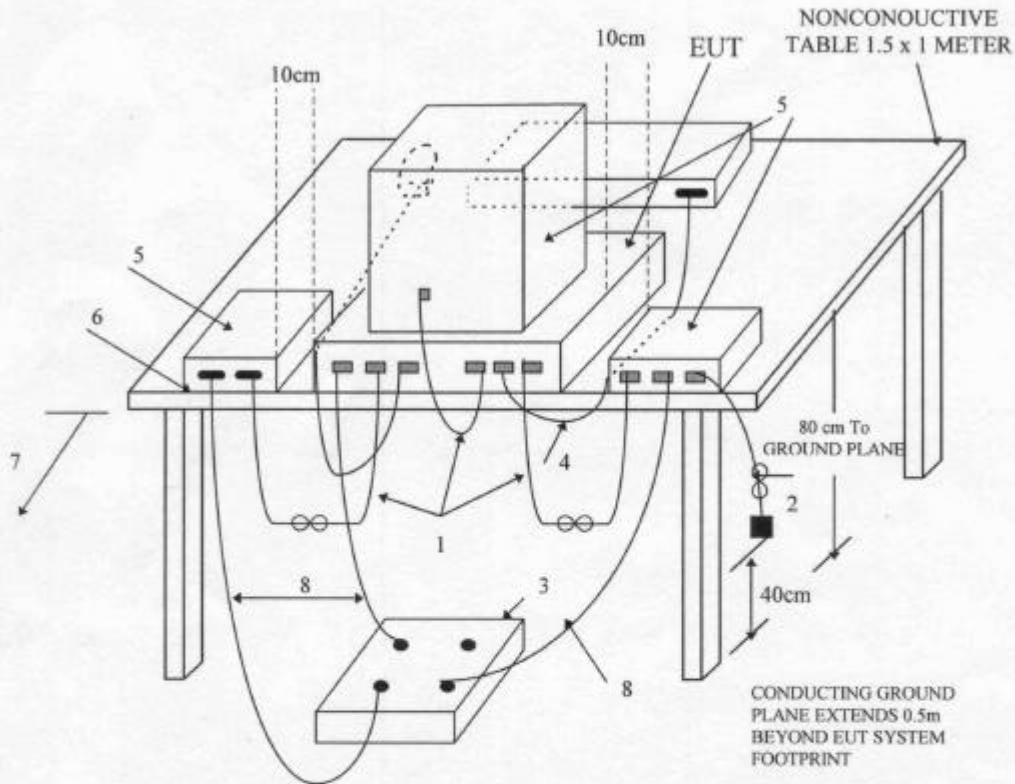

LEGEND:

1. Interconnecting cables that hang closer than 40 cm to the ground plane shall be folded back and forth forming a bundle 30 to 40 cm long, hanging approximately in the middle between ground plane and table.
2. I/O cables that are connected to a peripheral shall be bundled in center. The end of the cable may be terminated if required using correct terminating impedance. The total length shall not exceed 1m.
3. If LISNs are kept in the test setup for radiated emissions, it is preferred that they be installed under the ground plane with the receptacle flush with the ground plane.
4. Cables of hand-operated devices, such as keyboards, mice, etc., have to be placed as close as possible to the controller.
5. Non-EUT components of EUT system being tested.
6. The rear of all components of the system under test shall be located flush with the rear of the table.
7. No vertical conducting wall used.
8. Power cords drape to the floor and are routed over to receptacle.

**Test Configuration
Tabletop Equipment Radiated Emission**

4 CONFIGURATION OF THE EUT

Same as "Conducted Power Line test", section 4

5 EUT OPERATING CONDITION

5.1 Same as "Conducted Power Line test", section 5

5.2 The radiated emission in the frequency range from 30 MHz - 1000 MHz was test in a horizontal and vertical polarization at HomeTek Lab's open site II.

6 LIMIT OF RADIATED EMISSION CLASS A:

Frequency (MHz)	Measurement Distance	dBuV/m	uV/m
30 - 88	10 (M)	39	90
88 - 216	10 (M)	43.5	150
216 - 960	10 (M)	46.4	210
Above 960	10 (M)	49.5	300

6.1 The tighter limit shall apply at the edge between two frequency bands.

6.2 Distance refers to the distance in meters between the measuring instrument antenna and the closed point of any part of the device or system.

7 RESULT OF RADIATED EMISSION TEST (1)

- 7.1 The frequency range from 30 MHz to 1 GHz was investigated. All readings are quasi-peak values with resolution bandwidth of 120 kHz.
- 7.2 The measurements above 1 GHz with a resolution bandwidth of 1 MHz are peak reading at 10 meters.
- 7.3 The measurements were made at 10 meters of HomeTek Lab's open site II.
- 7.4 Temperature : 21 °C, Humidity : 72 % RH.
- 7.5 Radiated Emission data : **Horizontal**

Frequency (MHz)	Reading Level (dBuV)	ANT factor (dB/m)	Cable Loss (dB)	Emission Level (dBuV/m)	Emission Level (uV/m)	Limit (dBuV/m)	Limit (uV/m)
50.08	10.65	11.83	0.61	23.09	14.27	39.0	90
55.07	11.77	11.06	0.74	23.57	15.08	39.0	90
128.88	20.79	10.71	0.94	32.44	41.88	43.5	150
157.52	29.77	8.35	1.09	39.21	91.31	43.5	150
200.48	28.43	10.08	1.19	39.70	96.61	43.5	150
325.41	25.36	14.31	1.52	41.19	114.68	46.4	210
455.58	11.88	16.67	1.80	30.35	32.92	46.4	210
600.76	6.64	20.39	2.31	29.34	29.31	46.4	210

- Emission Level = Reading Level + ANT Factor + Cable Loss.
- Sample Calculation for 600.76 MHz .
- Corrected Reading : (6.64) + (20.39) + (2.31) = 29.34 . (Emission Level)

7.6 Radiated Emission data : **Vertical**

Frequency (MHz)	Reading Level (dBuV)	ANT factor (dB/m)	Cable Loss (dB)	Emission Level (dBuV/m)	Emission Level (uV/m)	Limit (dBuV/m)	Limit (uV/m)
50.06	19.28	13.62	0.61	33.51	47.37	39.0	90
55.05	22.84	11.79	0.74	35.37	58.68	39.0	90
130.16	17.31	12.00	0.96	30.27	32.62	43.5	150
157.52	20.40	7.65	1.09	29.14	28.64	43.5	150
206.09	25.89	10.39	1.19	37.47	74.73	43.5	150
233.88	21.01	12.60	1.32	34.93	55.78	46.4	210
325.42	26.68	13.57	1.52	41.77	122.60	46.4	210
601.42	8.26	18.70	2.31	29.27	29.07	46.4	210

- Emission Level = Reading Level + ANT Factor + Cable Loss.
- Sample Calculation for 601.42 MHz .
- Corrected Reading : (8.26) + (18.70) + (2.31) = 29.27 . (Emission Level)

REMARK :

1. Model : AMB-6501T
2. Measuring mode : 1024 x 768
3. Uncertainty in radiated emission measured : $\pm 4.0\text{dB}$.
4. “ * ”, means this data is worse case emission level.
5. Result : **PASSED**

8 PHOTO OF RADIATED EMISSION TEST

Test Mode : 1024 x 768



Front View

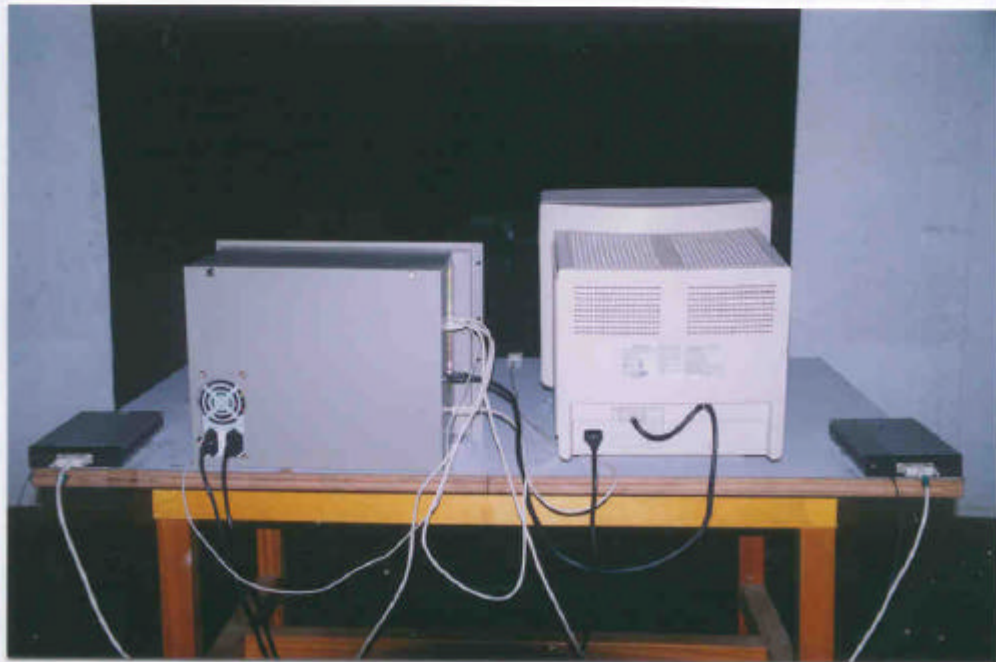

Rear View

9 RESULT OF RADIATED EMISSION TEST (2)

- 9.1 The frequency range from 30 MHz to 1 GHz was investigated. All readings are quasi-peak values with resolution bandwidth of 120 kHz.
- 9.2 The measurements above 1 GHz with a resolution bandwidth of 1 MHz are peak reading at 10 meters.
- 9.3 The measurements were made at 10 meters of HomeTek Lab's open site II.
- 9.4 Temperature : 21 °C, Humidity : 72 % RH.
- 9.5 Radiated Emission data : **Horizontal**

Frequency (MHz)	Reading Level (dBuV)	ANT factor (dB/m)	Cable Loss (dB)	Emission Level (dBuV/m)	Emission Level (uV/m)	Limit (dBuV/m)	Limit (uV/m)
54.24	18.70	10.96	0.71	30.37	33.00	39.0	90
81.36	26.12	5.23	0.86	32.21	40.78	39.0	90
233.89	27.59	12.36	1.32	41.27	115.74	46.4	210
260.34	23.73	13.09	1.35	38.17	81.00	46.4	210
455.56	15.05	16.67	1.80	33.52	47.42	46.4	210
467.78	17.99	16.63	1.98	36.60	67.61	46.4	210
488.11	19.03	17.66	1.88	38.57	84.82	46.4	210
618.26	17.64	19.91	2.17	39.72	96.83	46.4	210

- Emission Level = Reading Level + ANT Factor + Cable Loss.
- Sample Calculation for 618.26 MHz .
- Corrected Reading : (17.64) + (19.91) + (2.17) = 39.72 . (Emission Level)

9.6 Radiated Emission data : **Vertical**

Frequency (MHz)	Reading Level (dBuV)	ANT factor (dB/m)	Cable Loss (dB)	Emission Level (dBuV/m)	Emission Level (uV/m)	Limit (dBuV/m)	Limit (uV/m)
48.82	12.97	14.74	0.69	28.40	26.30	39.0	90
54.25	14.93	11.75	0.71	27.39	23.41	39.0	90
114.56	17.33	10.58	0.99	28.90	27.86	43.5	150
292.86	20.69	12.07	1.55	34.31	51.94	46.4	210
325.41	27.92	13.57	1.52	43.01	141.42	46.4	210
467.77	18.90	17.31	1.98	38.19	81.19	46.4	210
585.73	17.74	18.58	2.29	38.61	85.21	46.4	210
618.26	11.29	19.35	2.17	32.81	43.70	46.4	210

- Emission Level = Reading Level + ANT Factor + Cable Loss.
- Sample Calculation for 618.26 MHz .
- Corrected Reading : (11.29) + (19.35) + (2.17) = 32.81 . (Emission Level)

REMARK :

1. Model : AMB-6501T
2. Measuring mode : 640 x 480
3. Uncertainty in radiated emission measured : $\pm 4.0\text{dB}$.
4. “ * ”, means this data is worse case emission level.
5. Result : **PASSED**

10 PHOTO OF RADIATED EMISSION TEST

Test Mode : 640 x 480



Front View



Rear View

SAMPLE OF FCC LABEL

This device complies with part 15 of the FCC Rules.
Operation is subject to the following two conditions: (1)
This device may not cause harmful interference. And (2)
this device must accept any interference that may cause
undesired operation.

PHOTOS OF EUT



EUT Front View



EUT Rear View