



SPORTON LAB.

Certificate No: C050414

CERTIFICATE

● **EQUIPMENT** : Analog Display Panel
MODEL NO. : AMB-223AT, AMB-223A
APPLICANT : Astech Technology Co., Ltd.
6F-4, No. 351, Chung-Shan Rd., Sec. 2,
Chung-Ho City, Taipei, Taiwan, R.O.C.



I HEREBY CERTIFY THAT:

THE MEASUREMENTS SHOWN IN THIS TEST REPORT WERE MADE IN ACCORDANCE WITH THE PROCEDURES GIVEN IN **EUROPEAN COUNCIL DIRECTIVE 89/336/EEC**. THE EQUIPMENT WAS **PASSED** THE TEST PERFORMED ACCORDING TO **EUROPEAN STANDARD EN55022:1994/A1:1995/A2:1997 Class A, EN61000-3-2:1995, EN 61000-3-3:1995 and EN 55024:1998 (EN 61 000-4-2:1995, EN 61 000-4-3:1996, EN 61 000-4-4:1995, EN 61 000-4-5:1995, EN 61 000-4-6:1996, EN 61 000-4-8:1993, EN 61 000-4-11:1994)**. THE TEST WAS CARRIED OUT ON **May. 10, 2000** AT **SPORTON INTERNATIONAL INC. LAB.**

Lenore Chang

Lenore Chang
President

CE TEST REPORT

according to

**European Standard EN 55022:1994/A1:1995/A2:1997 Class A
EN61000-3-2:1995, EN 61000-3-3:1995
and EN 55024:1998
(EN 61 000-4-2:1995, EN 61 000-4-3:1996,
EN 61 000-4-4:1995, EN 61 000-4-5:1995, EN 61 000-4-6:1996,
EN 61 000-4-8:1993, EN 61 000-4-11:1994)**

Equipment : Analog Display Panel

Model No. : AMB-223AT, AMB-223A

Applicant : **Astech Technology Co., Ltd.**
6F-4, No. 351, Chung-Shan Rd., Sec. 2,
Chung-Ho City, Taipei, Taiwan, R.O.C.

- The test result refers exclusively to the test presented test model / sample.
- Without the written authorization of the test lab., the Test Report may not be copied.
- This test report is only applicable to European Community.

SPORTON International Inc.

6F, No. 106, Sec. 1, Hsin Tai Wu Rd., Hsi Chih, Taipei Hsien, Taiwan, R.O.C.

Table of Contents

CERTIFICATE OF COMPLIANCE 4

1. General Description of Equipment under Test 5

 1.1 Applicant..... 5

 1.2 Manufacturer..... 5

 1.3 Basic Description of Equipment under Test..... 5

 1.4 Feature of Equipment under Test..... 5

2. Test Configuration of Equipment under Test..... 6

 2.1 Test Manner..... 6

 2.2 Description of Test System 6

3. Test Software 9

4. General Information of Test 10

 4.1 Test Facility.....10

 4.2 Standard for Methods of Measurement10

 4.3 Test in Compliance with10

 4.4 Frequency Range Investigated.....10

 4.5 Test Distance.....10

5. Test of Conducted Powerline..... 11

 5.1 Description of Major Test Instruments11

 5.2 Test Procedures.....12

 5.3 Typical Test Setup Layout of Conducted Powerline.....13

 5.4 Test Result of AC Powerline Conducted Emission14

 5.5 Photographs of Conducted Powerline Test Configuration.....16

6. Test of Radiated Emission 17

 6.1 Description of Major Test Instruments17

 6.2 Test Procedures.....18

 6.3 Typical Test Setup Layout of Radiated Emission.....19

 6.4 Test Result of Radiated Emission20

 6.5 Photographs of Radiated Emission Test Configuration.....22

7. Harmonics Test 23

 7.1 Standard23

 7.2 Test Procedure23

 7.3 Test Equipment Settings23

 7.4 Test Setup23

 7.5 Current Harmonics Test.....24

8. Voltage Fluctuations Test 26

 8.1 Standard26

 8.2 Test Procedure26

 8.3 Test Equipment Settings26

 8.4 Test Setup26

 8.5 Test Result Of Voltage Fluctuation And Flicker Test.....27

 8.6 Photographs Of Harmonics Test, Voltage Fluctuation And Flicker Test.....29

9. Electrostatic Discharge Immunity Test (ESD)..... 30

 9.1 Test setup.....30

 9.2 Test Setup for Tests Performed in Laboratory30

 9.3 ESD Test Procedure32

 9.4 Test Severity Levels.....33

9.5 Test Points.....	34
9.6 Photographs of Electrostatic Discharge Immunity Test.....	36
10. Radio Frequency Electromagnetic Field Immunity Test (RS)	37
10.1 Test setup.....	37
10.2 Test Procedure	38
10.3 Test Severity Levels.....	38
10.4 Photographs of Radio Frequency Electromagnetic Field Immunity Test.....	39
11. Electrical Fast Transient/Burst Immunity Test (EFT/BURST).....	40
11.1 Test setup.....	40
11.2 Test on Power Line	41
11.3 Test on Communication Lines.....	41
11.4 Test Procedure	42
11.5 Test Severity Levels.....	43
11.6 Photographs of Electrical Fast Transient/BURST Immunity Test.....	44
12. Surge Immunity Test.....	45
12.1 Test Record	45
12.2 Test Level	45
12.3 Test Procedure	46
12.4 Photographs Of Surge Immunity Test	48
13. Conducted Disturbances Induced By Radio-Frequency Field Immunity Test (CS)	49
13.1 Test Level.....	49
13.2 Test Procedure	49
14. Power Frequency Magnetic Field immunity tests.....	51
14.1 Test Record	51
14.2 Test Setup	51
Photographs of Power Frequency Magnetic Field immunity tests	52
15. Voltage Dips, short interruptions and voltage variations immunity tests	53
15.1 Test Record Of Voltage Interruption	53
15.2 Test Record Of Voltage Dips.....	53
15.3 Testing Requirement And Procedure	54
15.4 Information of cables.....	54
15.5 Test conditions.....	54
15.6 Photographs Of Voltage Dips, Short Interruptions And Voltage Immunity Tests	55
16. Antenna Factor & Cable Loss	56
17. List of Measuring Equipment Used	57
18. Notice for Class A Product.....	59
19. Declaration of Conformity and the CE Mark.....	60
Appendix A. Photographs of EUT	A1 ~ A7

CERTIFICATE OF COMPLIANCE

according to

**European Standard EN 55022:1994/A1:1995/A2:1997 Class A
EN61000-3-2:1995, EN 61000-3-3:1995
and EN 55024:1998
(EN 61 000-4-2:1995, EN 61 000-4-3:1996,
EN 61 000-4-4:1995, EN 61 000-4-5:1995, EN 61 000-4-6:1996,
EN 61 000-4-8:1993, EN 61 000-4-11:1994)**

Equipment : Analog Display Panel

Model No. : AMB-223AT, AMB-223A

Applicant : **Astech Technology Co., Ltd.**
6F-4, No. 351, Chung-Shan Rd., Sec. 2,
Chung-Ho City, Taipei, Taiwan, R.O.C.

I HEREBY CERTIFY THAT :

The measurements shown in this test report were made in accordance with the procedures given in **EUROPEAN COUNCIL DIRECTIVE 89/336/EEC**. The equipment was *passed* the test performed according to European Standard **EN 55022:1994/A1:1995/A2:1997 Class A, EN61000-3-2:1995, EN 61000-3-3:1995 and EN 55024:1998 (EN 61 000-4-2:1995, EN 61 000-4-3:1996, EN 61 000-4-4:1995, EN 61 000-4-5:1995, EN 61 000-4-6:1996, EN 61 000-4-8:1993, EN 61 000-4-11:1994)**. The test was carried out on May. 10, 2000 at **SPORTON International Inc. LAB.** in Lin Kou.



Lenore Chang
President

SPORTON International Inc.

6F, No. 106, Sec. 1, Hsin Tai Wu Rd., Hsi Chih, Taipei Hsien, Taiwan, R.O.C.

1. General Description of Equipment under Test

1.1 Applicant

Astech Technology Co., Ltd.
6F-4, No. 351, Chung-Shan Rd., Sec. 2,
Chung-Ho City, Taipei, Taiwan, R.O.C.

1.2 Manufacturer

Same as 1.1.

1.3 Basic Description of Equipment under Test

Equipment : Analog Display Panel
Model No. : AMB-223AT, AMB-223A
Trade Name : Astech
AV Cable : Non-shielded, 1.2m
RS232 Cable : Shielded, 1.7m
Power Supply Type : Switching
AC Power Cord : Non-Shielded, 1.8m, 3 pin
DC Power cable : Shielded, 0.7m

1.4 Feature of Equipment under Test

12.1" SVGA color TFT LCD display
Front panel is NEMA 4/12 compliant
I/O port: RGB, RCA
Power Supply: DC/12V external power adapter
Max. resolution: 800 x 600
Touchscreen: controller - RS-232 interface

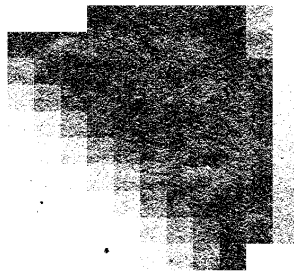

2. Test Configuration of Equipment under Test

2.1 Test Manner

- a. During testing, the interface cables and equipment positions were varied according to european Standard EN 55022.
- b. The DELL PS/2 Keyboard, PRIMAX PS/2 Mouse, HP Printer, ACEEX Modem, and EUT were connected to the FIC PC for EMI test. The PANASONIC Video Player was connected to the EUT.
- c. The DELL PS/2 Keyboard, PRIMAX PS/2 Mouse, and EUT were connected to the DELL PC for EMS test. The OAK VCD was connected to the EUT.
- d. Frequency range investigated: conduction 150 KHz to 30 MHz, radiation 30 MHz to 1000MHz.

2.2 Description of Test System

< EMI >

Support Unit 1. -- Personal Computer (FIC)

FCC ID	: N/A
Model No.	: P2L97
Power Supply Type	: Switching
Power Cord	: Non-Shielded
Serial No.	: SP0037
Data Cable	: Shielded
Remark	: This support device was tested to comply with FCC standards and authorized under a declaration of conformity.

Support Unit 2. -- PS/2 Keyboard (DELL)

FCC ID	: GYUM92SK
Model No.	: AT101(DE8M)
Serial No.	: SP0054
Data Cable	: Shielded, 1.9m

Support Unit 3. -- PS/2 Mouse (PRIMAX)

FCC ID	: EMJMUSJQ
Model No.	: MUS9J
Serial No.	: SP0045
Data Cable	: Shielded, 1.7m

Support Unit 4. -- Printer (HP)

FCC ID : B94C2642X
Model No. : DeskJet 400
Power Supply Type : Linear
Power Cord : Non-Shielded
Serial No. : SP0048
Data Cable : Braided-Shielded, 1.35m

Support Unit 5. -- Modem (ACEEX)

FCC ID : IFAXDM1414
Model No. : DM1414
Power Supply Type : Linear
Power Cord : Non-Shielded
Serial No. : SP0015
Data Cable : Shielded, 1.15m

Support Unit 6. -- Video Player (PANASONIC)

FCC ID : G8SA31185
Model No. : PV-S7670
Serial No. : SP0149
Data Cable : Non-Shielded, 1.2m

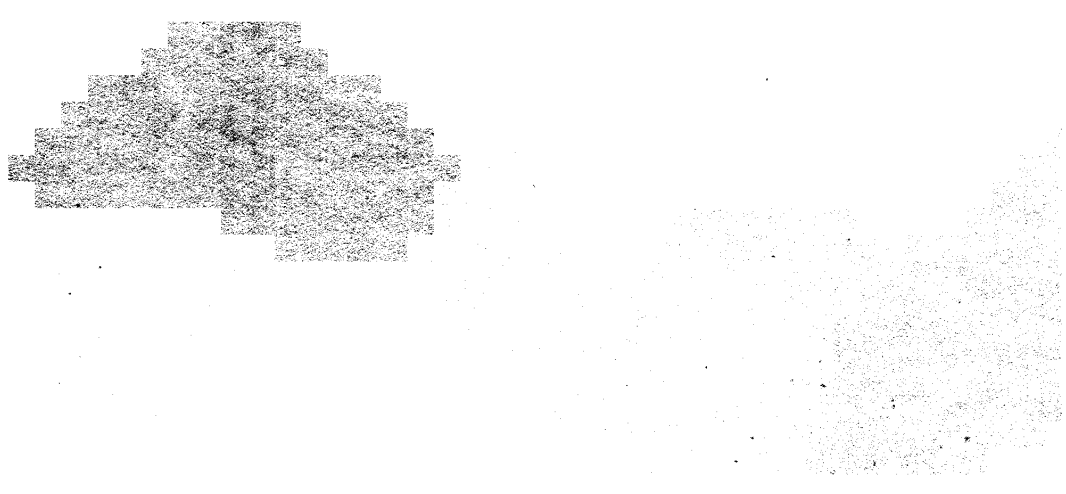

< EMS >

Support Unit 1. -- Personal Computer (DELL)

FCC ID : N/A
Model No. : DCS
Power Supply Type : Switching
Power Cord : Non-Shielded
Serial No. : SP0038
Data Cable : Shielded
Remark : This support device was tested to comply with FCC standards and authorized under a declaration of conformity.

Support Unit 2. -- PS/2 Keyboard (DELL)

FCC ID : GYUM92SK
Model No. : AT101(DE8M)
Serial No. : SP0054
Data Cable : Shielded, 1.9m

Support Unit 3. -- PS/2 Mouse (PRIMAX)

FCC ID : EMJMUSJQ
Model No. : MUS9J
Serial No. : SP0045
Data Cable : Shielded, 1.7m

Support Unit 4. -- VCD (OAK)

FCC ID : N/A
Model No. : LV-918
Serial No. : SP0140,
Data Cable : Non-Shielded, 1.2m

3. Test Software

< EMI >

An executive program, EMCTEST.EXE under WIN 98, which generates a complete line of continuously repeating " H" pattern was used as the test software.

The program was executed as follows :

- a. Turn on the power of all equipment.
- b. The PC reads the test program from the floppy disk drive and runs it.
- c. The PC sends " H" messages to the monitor, and the monitor displays " H" patterns on the screen.
- d. The PC sends " H" messages to the printer, then the printer prints them on the paper.
- e. The PC sends " H" messages to the modem.
- f. The PC sends " H" messages to the internal Hard Disk, and the Hard Disk reads and writes the message.
- g. Repeat the steps from b to f.

< EMS >

An executive program, EMITEST.EXE under WIN 98, which generates a complete line of continuously repeating " H" pattern was used as the test software.

The program was executed as follows :

- a. Turn on the power of all equipment.
- b. The PC reads the test program from the floppy disk drive and runs it.
- c. The PC sends " H" messages to the monitor, and the monitor displays " H" patterns on the screen.
- d. The PC sends " H" messages to the printer, then the printer prints them on the paper.
- e. The PC sends " H" messages to the modem.
- f. The PC sends " H" messages to the internal Hard Disk, and the Hard Disk reads and writes the message.
- g. Repeat the steps from b to f.

4. General Information of Test

4.1 Test Facility

< EMI >

This test was carried out by SPORTON International Inc.

Test Site Location : No. 30-2, Lin 6, Diing-Fwu Tsuen, Lin-Kou-Hsiang,
Taipei Hsien, Taiwan, R.O.C.
TEL : 886-2-2601-1640
FAX : 886-2-2601-1695

< EMS >

This test was carried out by SPORTON International Inc.

Test Site Location : No. 30-2, Lin 6, Diing-Fwu Tsuen, Lin-Kou-Hsiang,
Taipei Hsien, Taiwan, R.O.C.
TEL : 886-2-2601-1640
FAX : 886-2-2601-1695

4.2 Standard for Methods of Measurement

EMI Test (conduction and radiation) : European Standard EN 55022 Class A
Harmonics Test : European Standard EN 61000-3-2.
Voltage Fluctuations Test : European Standard EN 61000-3-3.
EMS Test : EN 55024:1998
(ESD: EN 61 000-4-2, RS: EN 61 000-4-3, EFT: EN 61 000-4-4, SURGE: EN 61 000-4-5,
CS: EN 61 000-4-6, Power Frequency Magnetic Field: EN 61 000-4-8, DIPS: EN 61 000-4-11)

4.3 Test in Compliance with

EMI Test (conduction and radiation) : European Standard EN 55022 Class A
Harmonics Test : European Standard EN 61000-3-2.
Voltage Fluctuations Test : European Standard EN 61000-3-3.
EMS Test : EN 55024:1998
(ESD: EN 61 000-4-2, RS: EN 61 000-4-3, EFT: EN 61 000-4-4, SURGE: EN 61 000-4-5,
CS: EN 61 000-4-6, Power Frequency Magnetic Field: EN 61 000-4-8, DIPS: EN 61 000-4-11)

4.4 Frequency Range Investigated

- Conducted emission test: from 150 kHz to 30 MHz
- Radiated emission test: from 30 MHz to 1,000 MHz
- Radio frequency electromagnetic field immunity test : 80-1000 MHz.

4.5 Test Distance

The test distance of radiated emission test from antenna to EUT is 10 M.

The test distance of radio frequency electromagnetic field immunity test from antenna to EUT is 3 M.

5. Test of Conducted Powerline

Conducted Emissions were measured from 150 kHz to 30 MHz with a bandwidth of 9 kHz on the 230V AC power and return leads of the EUT according to the methods defined in European Standard EN 55022 Clause 9. The EUT was placed on a nonmetallic stand in a shielded room 0.8 meters above the ground plane as shown in section 5.3. The interface cables and equipment positioning were varied within limits of reasonable applications to determine the position producing maximum conducted emissions.

5.1 Description of Major Test Instruments

Test Receiver	HP 8591EM
Attenuation	0 dB
Start Frequency	0.15 MHz
Stop Frequency	30 MHz
Step MHz	0.007 MHz
IF Bandwidth	9 kHz

5.2 Test Procedures

- a. The EUT was placed on a desk 0.8 meters height from the metal ground plane and 0.4 meter from the conducting wall of the shielding room and it was kept at least 0.8 meters from any other grounded conducting surface.
- b. Connect EUT to the power mains through a line impedance stabilization network (LISN).
- c. All the support units are connect to the other LISN.
- d. The LISN provides 50 ohm coupling impedance for the measuring instrument.
- e. The CISPR states that a 50 ohm , 50 microhenry LISN should be used.
- f. Both sides of AC line were checked for maximum conducted interference.
- g. The frequency range from 150 kHz to 30 MHz was searched.
- h. Set the test-receiver system to Peak Detect Function and Specified Bandwidth with Maximum Hold Mode.
- i. If the emission level of the EUT in peak mode was 6 dB lower than the limit specified, then testing will be stopped and peak values of EUT will be reported, otherwise, the emissions which do not have 6 dB margin will be retested one by one using the quasi-peak method and/or average methods and reported.

5.3 Typical Test Setup Layout of Conducted Powerline

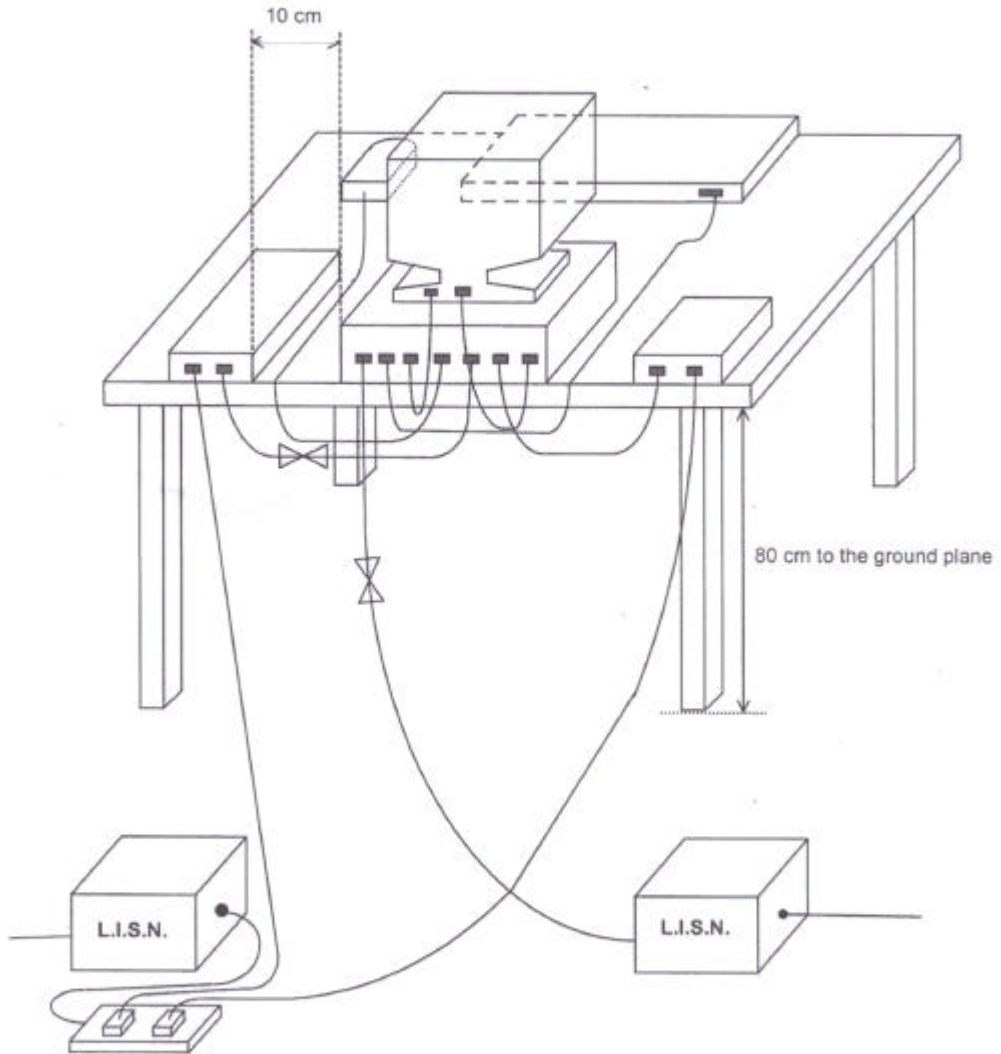

5.4 Test Result of AC Powerline Conducted Emission

5.4.1 Test mode : VGA Mode 800x600

Frequency Range of Test : from 150 kHz to 30 MHz

Temperature : 27°C

Relative Humidity : 58 %

Test Date : May. 5, 2000

The Conducted Emission test was passed at minimum margin LINE 0.894 MHz / 55.70 dBuV.

Freq. (MHz)	Line or Neutral	Meter Reading				Limits				Margin	
		Q.P. (dBuV)	A.V. (dBuV)	Q.P. (uV)	A.V. (uV)	Q.P. (dBuV)	A.V. (dBuV)	Q.P. (uV)	A.V. (uV)	Q.P. (dB)	A.V. (dB)
0.766	L	55.00	55.00	562.34	562.34	73.00	60.00	4466.84	1000.00	-18.0	-5.0
0.894	L	55.70	55.70	609.54	609.54	73.00	60.00	4466.84	1000.00	-17.3	-4.3
1.021	L	55.40	55.30	588.84	582.10	73.00	60.00	4466.84	1000.00	-17.6	-4.7
0.896	N	55.60	55.60	602.56	602.56	73.00	60.00	4466.84	1000.00	-17.4	-4.4
0.960	N	55.60	55.50	602.56	595.66	73.00	60.00	4466.84	1000.00	-17.4	-4.5
1.024	N	55.30	55.20	582.10	575.44	73.00	60.00	4466.84	1000.00	-17.7	-4.8

Test Engineer : Aldrich
Aldrich Hong

5.4.2 Test mode : AV Mode

Frequency Range of Test : from 150 kHz to 30 MHz

Temperature : 27°C

Relative Humidity : 58 %

Test Date : May. 5, 2000

The Conducted Emission test was passed at minimum margin **NEUTRAL 0.962 MHz / 54.70 dBuV**.

Freq. (MHz)	Line or Neutral	Meter Reading				Limits				Margin	
		Q.P. (dBuV)	A.V. (dBuV)	Q.P. (uV)	A.V. (uV)	Q.P. (dBuV)	A.V. (dBuV)	Q.P. (uV)	A.V. (uV)	Q.P. (dB)	A.V. (dB)
0.964	L	54.70	54.60	543.25	537.03	73.00	60.00	4466.84	1000.00	-18.3	-5.4
0.962	N	54.80	54.70	549.54	543.25	73.00	60.00	4466.84	1000.00	-18.2	-5.3
0.900	L	54.70	54.60	543.25	537.03	73.00	60.00	4466.84	1000.00	-18.3	-5.4
1.028	L	54.50	54.40	530.88	524.81	73.00	60.00	4466.84	1000.00	-18.5	-5.6
0.898	N	54.80	54.70	549.54	543.25	73.00	60.00	4466.84	1000.00	-18.2	-5.3
1.026	N	54.60	54.50	537.03	530.88	73.00	60.00	4466.84	1000.00	-18.4	-5.5

Test Engineer : Aldrich
Aldrich Hong

5.5 Photographs of Conducted Powerline Test Configuration

- The photographs show the configuration that generates the maximum emission.

FRONT VIEW



REAR VIEW



6. Test of Radiated Emission

Radiated emissions from 30 MHz to 1000 MHz were measured with a bandwidth of 120 kHz according to the methods defines in European Standard EN 55022, Clause 10. The EUT was placed on a nonmetallic stand in the open-field site, 0.8 meter above the ground plane, as shown in section 6.3. The interface cables and equipment positions were varied within limits of reasonable applications to determine the positions producing maximum radiated emissions.

6.1 Description of Major Test Instruments

Amplifier	(HP 8447D)
Attenuation	0 dB
RF Gain	25 dB
Signal Input	0.1 MHz to 1.3 GHz
Spectrum Analyzer	(HP 8568B)
Attenuation	0 dB
Start Frequency	30 MHz
Stop Frequency	1,000 MHz
Resolution Bandwidth	1 MHz
Video Bandwidth	1 MHz
Signal Input	100 Hz to 1.5 GHz
Quasi-Peak Adapter	(HP 85650A)
Resolution Bandwidth	120 KHz
Frequency Band	30 MHz to 1 GHz
Quasi-Peak Detector	ON for Quasi-Peak Mode; OFF for Peak Mode

6.2 Test Procedures

- a. The EUT was placed on a rotatable table top 0.8 meter above ground.
- b. The EUT was set 10 meters from the interference-receiving antenna which was mounted on the top of a variable height antenna tower.
- c. The table was rotated 360 degrees to determine the position of the highest radiation.
- d. The antenna is a half wave dipole and its height is varied between one meter and four meters above ground to find the maximum value of the field strength both horizontal polarization and vertical polarization of the antenna are set to make the measurement.
- e. For each suspected emission the EUT was arranged to its worst case and then tune the antenna tower (from 1 M to 4 M) and turn table (from 0 degree to 360 degrees) to find the maximum reading.
- f. Set the test-receiver system to Peak Detect Function and specified bandwidth with Maximum Hold Mode.
- g. If the emission level of the EUT in peak mode was 6 dB lower than the limit specified, then testing will be stopped and peak values of EUT will be reported, otherwise, the emissions which do not have 6 dB margin will be repeated one by one using the quasi-peak method and reported.

6.3 Typical Test Setup Layout of Radiated Emission

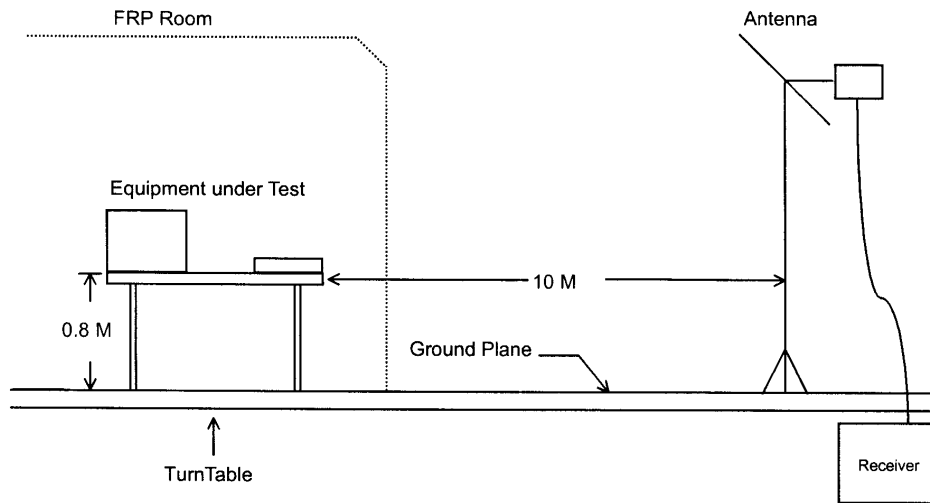

6.4 Test Result of Radiated Emission

6.4.1 Test mode : VGA Mode 800 x 600

Frequency Range of Test : from 30 MHz to 1000 MHz

Test Distance : 10 M

Temperature : 28°C

Relative Humidity : 41 %

Test Date : May. 3, 2000

Emission level (dBuV/m) = 20 log Emission level (uV/m)

Corrected Reading : Antenna Factor + Cable Loss + Reading = Emission

The Radiated Emission test was passed at minimum margin:

VERTICAL 188.984 MHz / 37.78 dBuV Antenna Height 1 Meter , Turntable Degree 107 °.

Frequency (MHz)	Polarity	Antenna Factor (dB/m)	Cable Loss (dB)	Reading (dBuV)	Limits		Emission (dBuV/m)	Level (uV/m)	Margin (dB)
					(dBuV/m)	(uV/m)			
190.056	H	9.50	1.50	25.37	40.00	100.00	36.37	65.84	-3.63
419.200	H	16.82	2.19	24.15	47.00	223.87	43.16	143.88	-3.84
439.471	H	16.94	2.45	23.83	47.00	223.87	43.22	144.88	-3.78
598.400	H	19.65	2.70	21.05	47.00	223.87	43.40	147.91	-3.60
188.984	V	9.52	1.50	26.76	40.00	100.00	37.78	77.45	-2.22
479.200	V	17.17	2.40	24.19	47.00	223.87	43.76	154.17	-3.24

Test Engineer :



WILLIAM LEE

6.4.2 Test mode : AV Mode

- Frequency Range of Test : from 30 MHz to 1000 MHz
- Test Distance : 10 M
- Temperature : 28°C
- Relative Humidity : 41 %
- Test Date : May. 4, 2000
- Emission level (dBuV/m) = 20 log Emission level (uV/m)
- Corrected Reading : Antenna Factor + Cable Loss + Reading = Emission

The Radiated Emission test was passed at minimum margin:

VERTICAL 400.000 MHz / 44.18 dBuV Antenna Height 1 Meter , Turntable Degree 260 °.

Frequency (MHz)	Polarity	Antenna Factor (dB/m)	Cable Loss (dB)	Reading (dBuV)	Limits		Emission (dBuV/m)	Level (uV/m)	Margin (dB)
					(dBuV/m)	(uV/m)			
201.000	H	9.37	1.50	21.62	40.00	100.00	32.49	42.12	-7.51
400.000	H	16.70	2.30	21.68	47.00	223.87	40.68	108.14	-6.32
479.200	H	17.17	2.40	19.39	47.00	223.87	38.96	88.72	-8.04
238.400	V	11.92	1.61	28.11	47.00	223.87	41.64	120.78	-5.36
400.000	V	16.70	2.30	25.18	47.00	223.87	44.18	161.81	-2.82
440.000	V	16.94	2.46	23.04	47.00	223.87	42.44	132.43	-4.56

Test Engineer : *William*
WILLIAM LEE

6.5 Photographs of Radiated Emission Test Configuration

- The photographs show the configuration that generates the maximum emission.

FRONT VIEW

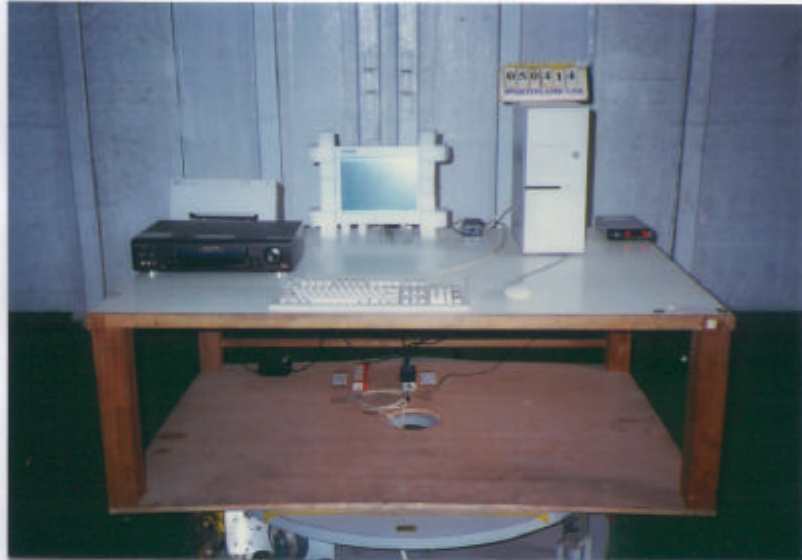

REAR VIEW

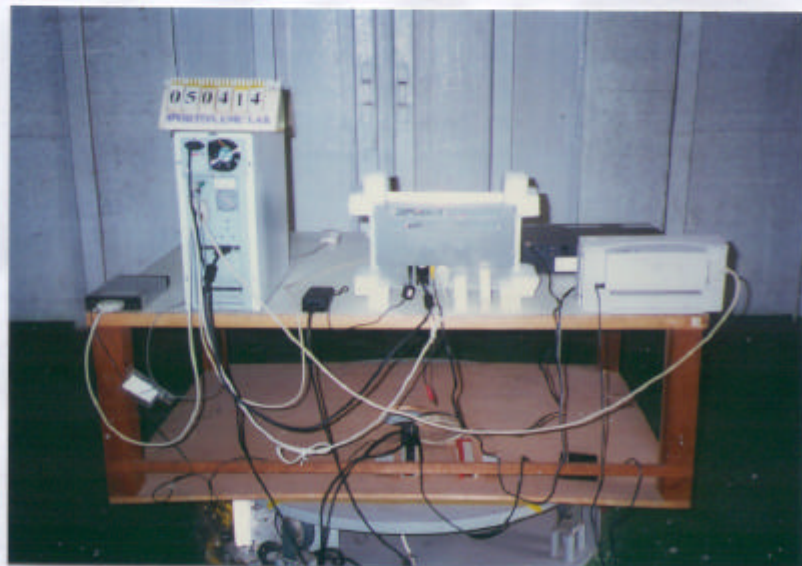

7. Harmonics Test

7.1 Standard

- Product Standard : EN 61000-3-2 (1995)

7.2 Test Procedure

The measured values of the harmonics components of the input current, including line current and neutral current, shall be compared with the limits given in Clause 4.

7.3 Test Equipment Settings

- Line Voltage : 230 V
- Line Frequency : 50 Hz
- Device Class : A
- Current Measurement Range : High
- Measurement Delay : 10.0 seconds
- Test Duration : 2.00 minutes
- Class determination Pre-test Duration : 10.00 seconds

7.4 Test Setup

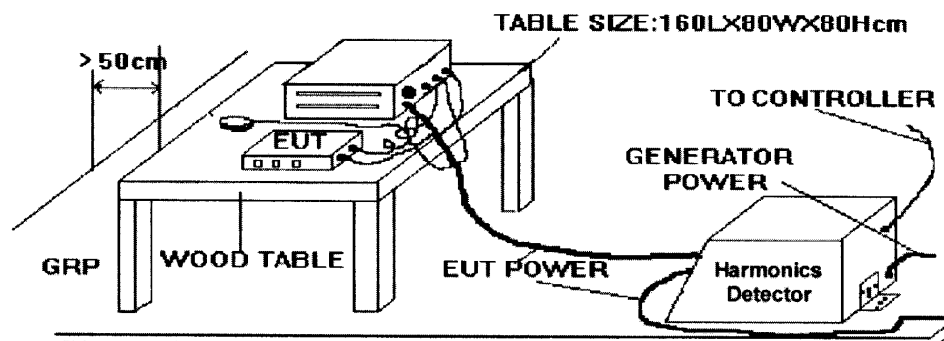

7.5 Current Harmonics Test

7.5.1 Test Data Of Current Harmonics

- FINAL TEST RESULT : **PASS**
- Fundamental Current : 0.091 A
- Real Power : 19.4 W
- Power Factor : 0.430
- Percent in Envelope : 100 %
- Temperature : 26 °C
- Relative Humidity : 53% RH
- Test Date : May. 10, 2000

Harmonic Number	Standard Limit (A rms)	Cursor Value (A rms)	Cursor Value (% Limit)	Mean Value (A rms)	Mean Value (% Limit)	Max. Span Value (A rms)
Fund.		0.0900		0.0903		0.0911
2	1.0800	0.0023	0.2	0.0025	0.2	0.0035
3	2.3000	0.0770	3.3	0.0775	3.4	0.0782
4	0.4300	0.0014	0.3	0.0014	0.3	0.0019
5	1.1400	0.0732	6.4	0.0734	6.4	0.0739
6	0.3000	0.0008	0.3	0.0008	0.3	0.0013
7	0.7700	0.0683	8.9	0.0686	8.9	0.0693
8	0.2300	0.0006	0.3	0.0004	0.2	0.0009
9	0.4000	0.0624	15.6	0.0626	15.7	0.0630
10	0.1840	0.0005	0.3	0.0003	0.1	0.0008
11	0.3300	0.0559	16.9	0.0557	16.9	0.0562
12	0.1533	0.0004	0.3	0.0003	0.2	0.0007
13	0.2100	0.0487	23.2	0.0483	23.0	0.0488
14	0.1314	0.0009	0.7	0.0007	0.5	0.0012
15	0.1500	0.0408	27.2	0.0406	27.1	0.0411
16	0.1150	0.0003	0.3	0.0002	0.2	0.0005
17	0.1324	0.0334	25.2	0.0329	24.8	0.0335
18	0.1022	0.0002	0.2	0.0002	0.2	0.0005
19	0.1184	0.0260	21.9	0.0253	21.4	0.0260
20	0.0920	0.0001	0.1	0.0001	0.1	0.0004
21	0.1071	0.0187	17.5	0.0183	17.1	0.0191
22	0.0836	0.0001	0.1	0.0001	0.1	0.0003
23	0.0978	0.0127	13.0	0.0121	12.4	0.0128
24	0.0767	0.0001	0.2	0.0001	0.1	0.0004
25	0.0900	0.0074	8.2	0.0070	7.7	0.0076
26	0.0708	0.0001	0.2	0.0001	0.2	0.0003
27	0.0833	0.0037	4.5	0.0033	4.0	0.0038
28	0.0657	0.0001	0.1	0.0001	0.2	0.0004
29	0.0776	0.0029	3.7	0.0029	3.8	0.0033
30	0.0613	0.0002	0.4	0.0001	0.2	0.0003
31	0.0726	0.0042	5.8	0.0044	6.1	0.0049
32	0.0575	0.0001	0.2	0.0002	0.3	0.0004
33	0.0682	0.0054	8.0	0.0056	8.2	0.0059
34	0.0541	0.0002	0.3	0.0002	0.3	0.0003
35	0.0643	0.0060	9.3	0.0060	9.4	0.0062
36	0.0511	0.0001	0.2	0.0001	0.3	0.0003
37	0.0608	0.0059	9.7	0.0058	9.6	0.0061
38	0.0484	0.0000	0.1	0.0001	0.3	0.0003
39	0.0577	0.0053	9.2	0.0051	8.9	0.0053
40	0.0460	0.0000	0.1	0.0001	0.2	0.0003

Test Engineer : 
 ROXY CHOU

7.5.2 Test Graph Of Harmonics

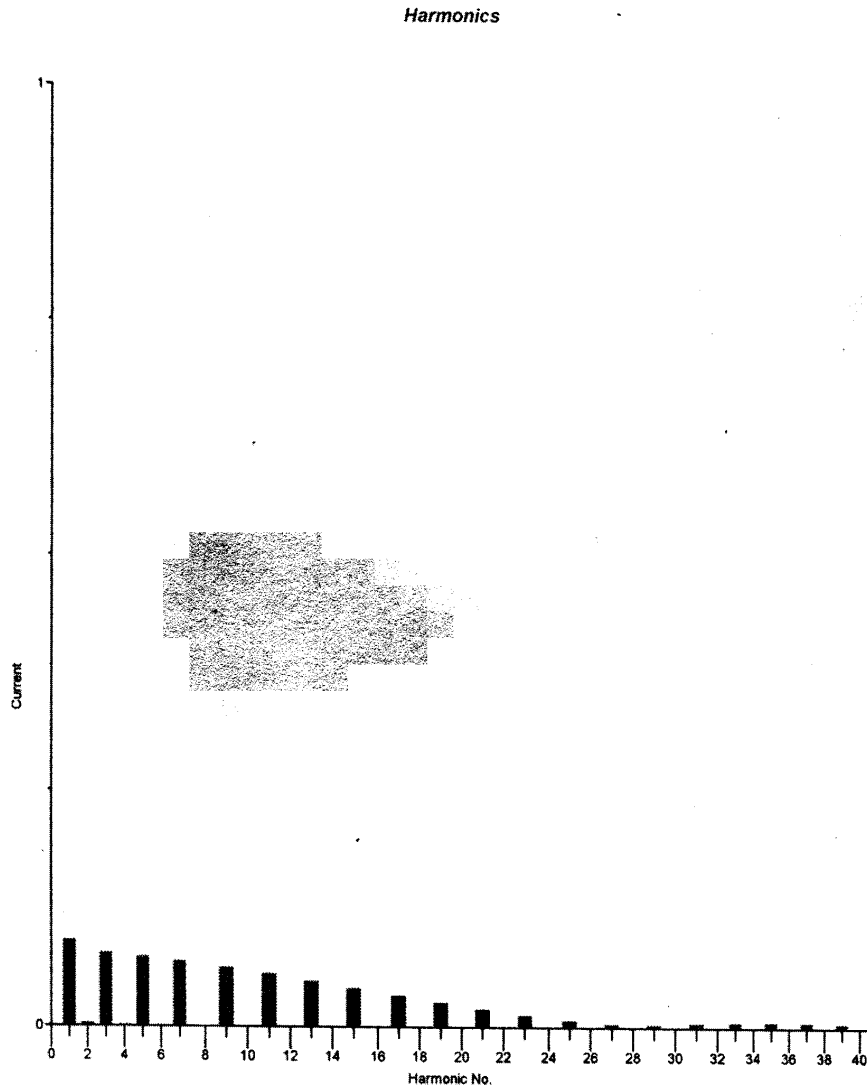

8. Voltage Fluctuations Test

8.1 Standard

- Product Standard : EN 61000-3-3 (1995)

8.2 Test Procedure

The equipment shall be tested under the conditions of **Clause 5**.

The total impedance of the test circuit, excluding the appliance under test, but including the internal impedance of the supply source, shall be equal to the reference impedance. The stability and tolerance of the reference impedance shall be adequate to ensure that the overall accuracy of $\pm 8\%$ is achieved during the whole assessment procedure.

8.3 Test Equipment Settings

- Line Voltage : 230 V
- Line Frequency : 50 Hz
- Measurement Delay : 10.0 seconds
- Pst Integration Time : 10 minutes
- Pst Integration Periods : 1
- Test Duration : 00:10:00 minutes

8.4 Test Setup

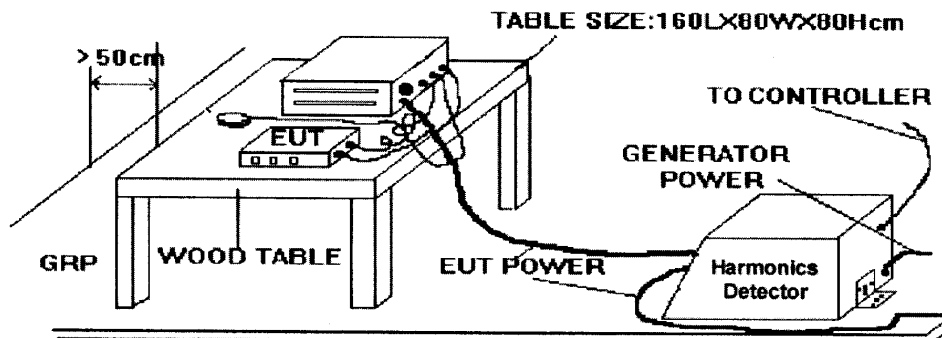

8.5 Test Result Of Voltage Fluctuation And Flicker Test

8.5.1 Test Data Of Voltage Fluctuation And Flicker

- FINAL TEST RESULT : **PASS**
- Temperature : 26 °C
- Relative Humidity : 53% RH
- Test Date : May. 10, 2000

	Pst	Plt	Dc (%)	Dmax (%)	Dt (%)
Reading	0.070	0.00	0.00	0.00	0.00
Limit	0.65	1.0	3.0	4.0	3.0

Test Engineer : 

ROXY CHOU

8.5.2 Test Graph Of Voltage Fluctuation And Flicker

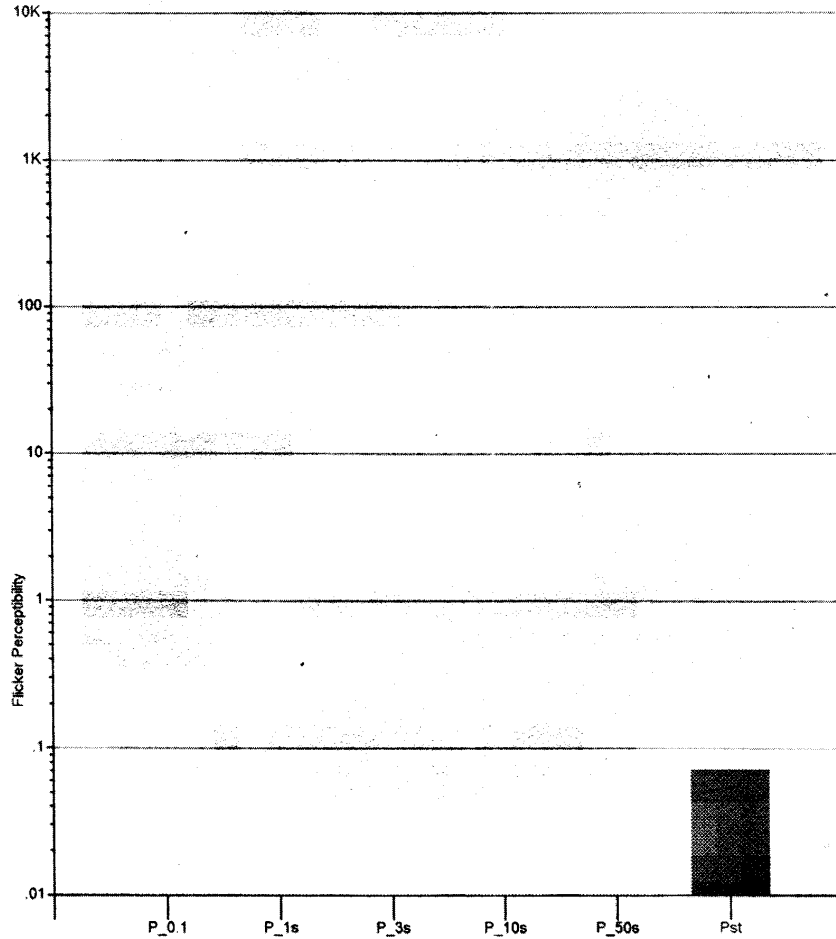

8.6 Photographs Of Harmonics Test, Voltage Fluctuation And Flicker Test

FRONT VIEW



REAR VIEW



9. Electrostatic Discharge Immunity Test (ESD)

- Pass Performance Criteria : B
- Basic Standard : EN 61 000-4-2:1995
- Generic Standard : EN 55024:1998
- Level : 3 for air discharge,
: 2 for contact discharge
- Tested voltage : $\pm 2 / \pm 4 / \pm 8$ KV for air discharge,
: $\pm 2 / \pm 4$ KV for contact discharge
- Temperature : 23 °C
- Relative Humidity : 48 %
- Test Date : May. 10, 2000

9.1 Test setup

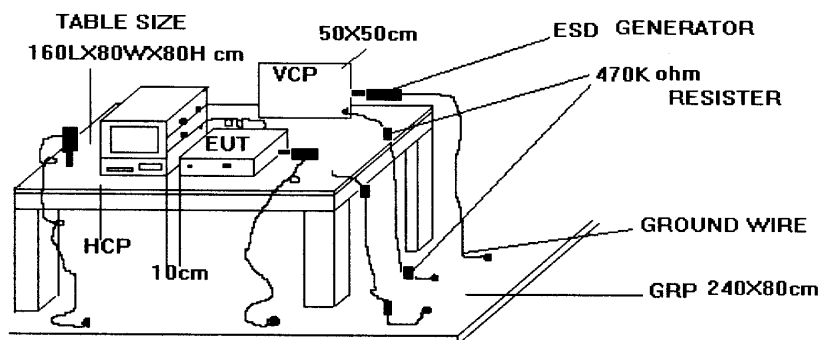

The test setup consists of the test generator, EUT and auxiliary instrumentation necessary to perform DIRECT and INDIRECT application of discharges to the EUT as applicable, in the follow manner :

- a. CONTACT DISCHARGE to the conductive surfaces and to coupling plane;
- b. AIR DISCHARGE at insulating surfaces.

The preferred test method is that of type tests performed in laboratories and the only accepted method of demonstrating conformance with this standard. The EUT was arranged as closely as possible to arrangement in final installed conditions.

9.2 Test Setup for Tests Performed in Laboratory

A ground reference plane was provided on the floor of the test site. It was a metallic sheet (copper or

aluminum) of 0.25 mm, minimum thickness; other metallic may be used but they shall have at least 0.65 mm thickness. In the SPORTON EMC LAB., we provided 1 mm thickness aluminum ground reference plane or 1 mm thickness stainless steel ground reference plane. The minimum size of the ground reference plane is 1 m x 1 m, the exact size depending on the dimensions of the EUT. It was connected to the protective grounding system.

The EUT was arranged and connected according to its functional requirements. A distance of 1m minimum was provided between the EUT and the wall of the lab. and any other metallic structure. In cases where this length exceeds the length necessary to apply the discharges to the selected points, the excess length shall, where possible, be placed non-inductively off the ground reference plane and shall not come closer than 0.2m to other conductive parts in the test setup.

Where the EUT is installed on a metal table, the table was connected to the reference plane via a cable with a 470k ohm resistor located at each end, to prevent a build-up of charge. The test setup was consist a wooden table, 0.8m high, standing on the ground reference plane. A HCP, 1.6 m x 0.8 m, was placed on the table. The EUT and cables was isolated from the HCP by an insulating support 0.5 mm thick. The VCP size, 0.5 m x 0.5 m.

9.3 ESD Test Procedure

- a. In the case of air discharge testing the climatic conditions shall be within the following ranges:
- ambient temperature: 15°C to 35°C;
 - relative humidity : 30% to 60%;
 - atmospheric pressure : 68 KPa (680 mbar) to 106 KPa (1060 mbar).
- b. Test programs and software shall be chosen so as to exercise all normal modes of operation of the EUT. The use of special exercising software is encouraged, but permitted only where it can be shown that the EUT is being comprehensively exercised.
- c. The test voltage shall be increased from the minimum to the selected test severity level, in order to determine any threshold of failure. The final severity level should not exceed the product specification value in order to avoid damage to the equipment.
- d. The test shall be performed with single discharges. On preselected points at least ten single discharges (in the most sensitive polarity) shall be applied.
- e. For the time interval between successive single discharges an initial value of one second is recommended. Longer intervals may be necessary to determine whether a system failure has occurred.
- f. In the case of contact discharges, the tip of the discharge electrode shall touch the EUT before the discharge switch is operated.
- g. In the case of painted surface covering a conducting substrate, the following procedure shall be adopted :
- If the coating is not declared to be an insulating coating by the equipment manufacturer, then the pointed tip of the generator shall penetrate the coating so as to make contact with the conducting substrate.
 - Coating declared as insulating by the manufacturer shall only be submitted to the air discharge.
 - The contact discharge test shall not be applied to such surfaces.
- h. In the case of air discharges, the round discharge tip of the discharge electrode shall be approached as fast as possible (without causing mechanical damage) to touch the EUT . After each discharge, the ESD generator (discharge electrode) shall be removed from the EUT. The generator is then retriggered for a new single discharge. This procedure shall be repeated until the discharges are completed. In the case of an air discharge test, the discharge switch, which is used for contact discharge, shall be closed.

9.4 Test Severity Levels

9.4.1 Contact Discharge

Level	Test Voltage (KV) of Contact discharge
1	±2
2	±4
3	±6
4	±8
X	Specified

Remark : "X" is an open level.

9.4.2 Air Discharge

Level	Test Voltage (KV) of Air Discharge
1	±2
2	±4
3	±8
4	±15
X	Specified

Remark : "X" is an open level.

9.5 Test Points

9.5.1 Test Result of Air Discharge

Test Point	Voltage	Tested No.	Observation	Result
Case	$\pm 2 / \pm 4 / \pm 8$ KV	BY 10	NORMAL	PASS
Screw	$\pm 2 / \pm 4 / \pm 8$ KV	BY 10	NORMAL	PASS
Bracket	$\pm 2 / \pm 4 / \pm 8$ KV	BY 10	NORMAL	PASS
COM1 port	$\pm 2 / \pm 4 / \pm 8$ KV	BY 10	NORMAL	PASS
Button of control panel	$\pm 2 / \pm 4 / \pm 8$ KV	BY 10	NORMAL	PASS
LED	$\pm 2 / \pm 4 / \pm 8$ KV	BY 10	NORMAL	PASS
DC Input jack	$\pm 2 / \pm 4 / \pm 8$ KV	BY 10	NORMAL	PASS
VGA port	$\pm 2 / \pm 4 / \pm 8$ KV	BY 10	NORMAL	PASS
Voice Jack	$\pm 2 / \pm 4 / \pm 8$ KV	BY 10	NORMAL	PASS

9.5.2 Test Result of Contact Discharge

Polarity	Voltage	Tested No.	Observation	Result
Horizontal(At Front)	±2 / ±4 KV	BY 25	NORMAL	PASS
Horizontal (At Left)	±2 / ±4 KV	BY 25	NORMAL	PASS
Horizontal (At Right)	±2 / ±4 KV	BY 25	NORMAL	PASS
Horizontal (At Rear)	±2 / ±4 KV	BY 25	NORMAL	PASS
Vertical (At Front)	±2 / ±4 KV	BY 25	NORMAL	PASS
Vertical (At Left)	±2 / ±4 KV	BY 25	NORMAL	PASS
Vertical (At Right)	±2 / ±4 KV	BY 25	NORMAL	PASS
Vertical (At Rear)	±2 / ±4 KV	BY 25	NORMAL	PASS
Case	±2 / ±4 KV	BY 25	NORMAL	PASS
Screw	±2 / ±4 KV	BY 25	NORMAL	PASS
Bracket	±2 / ±4 KV	BY 25	NORMAL	PASS
COM1 port	±2 / ±4 KV	BY 25	NORMAL	PASS
VGA port	±2 / ±4 KV	BY 25	NORMAL	PASS
Voice Jack	±2 / ±4 KV	BY 25	NORMAL	PASS

Test Engineer : 
 ROXY CHOU

9.6 Photographs of Electrostatic Discharge Immunity Test

FRONT VIEW



REAR VIEW



10. Radio Frequency Electromagnetic Field Immunity Test (RS)

- Pass Performance Criteria : A
- Basic Standard : EN 61 000-4-3:1996
- Generic Standard : EN 55024:1998
- Level : 2
- Frequency Range : 80-1000 MHz
- Field Strength : 3 V/m (Modulated 80% AM)
- Temperature : 23 °C
- Relative Humidity : 56 %
- Test Date : May. 10, 2000

10.1 Test setup

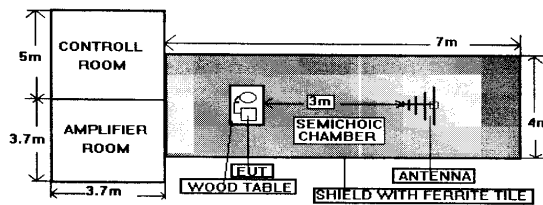

NOTE : The SPORTON 7m x 4m x 4m semichoic chamber is compliance with the sixteen points uniform field requirement as stated in IEC 1000-4-3 Section 6.2.

The procedure defined in this part requires the generation of electromagnetic fields within which the test sample is placed and its operation observed. To generate fields that are useful for simulation of actual (field) conditions may require significant antenna drive power and the resultant high field strength levels. To comply with local regulations and to prevent biological hazards to the testing personnel, it is recommended that these tests be carried out in a shielded enclosure or semichoic chamber.

10.2 Test Procedure

- a. The equipment to be tested is placed in the center of the enclosure on a wooden table. The equipment is then connected to power and signal leads according to pertinent installation instructions.
- b. The bilog antenna which is enabling the complete frequency range of 80-1000 MHz is placed 3m away from the equipment. The required field strength is determined by placing the field strength meter(s) on top of or directly alongside the equipment under test and monitoring the field strength meter via a remote field strength indicator outside the enclosure while adjusting the continuous-wave to the applicable antennae.
- c. The test is normally performed with the antenna facing the most sensitive side of the EUT. The polarization of the field generated by the biconical antenna necessitates testing each position twice, once with the antenna positioned vertically and again with the antenna positioned horizontally. The circular polarization of the field from the log-spiral antenna makes a change of position of the antenna unnecessary.
- d. At each of the above conditions, the frequency range is swept 80-1000 MHz, pausing to adjust the R.F. signal level or to switch oscillators and antenna. The rate of sweep is in the order of 1.5×10^{-3} decades/s. The sensitive frequencies or frequencies of dominant interest may be discretely analyzed.

10.3 Test Severity Levels

Frequency Band : 80-1000 MHz

Level	Test field strength (V/m)
1	1
2	3
3	10
X	Specified

Remark : "X" is an open class.

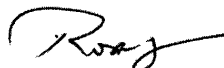
Test Engineer : 

ROXY CHOU

10.4 Photographs of Radio Frequency Electromagnetic Field Immunity Test

FRONT VIEW



REAR VIEW

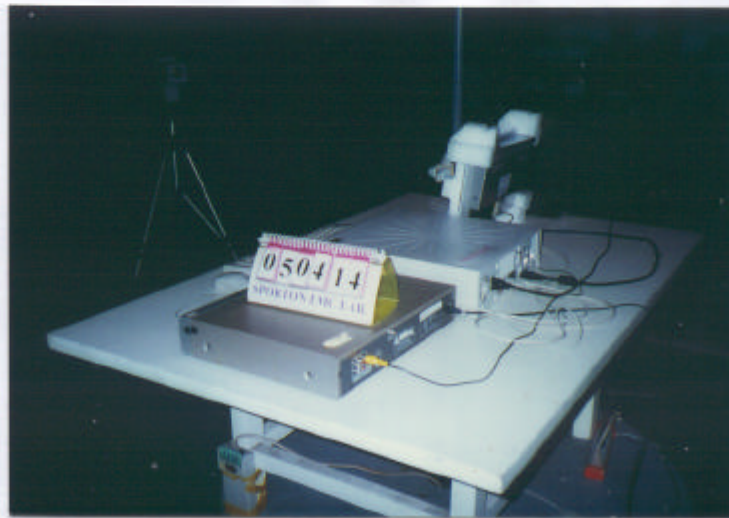

11. Electrical Fast Transient/Burst Immunity Test (EFT/BURST)

- Pass Performance Criteria : B
- Basic Standard : EN 61 000-4-4:1995
- Generic Standard : EN 55024:1998
- Level : on Power Supply -- 2
- Tested voltage : on Power Supply -- 0.5/1.0 KV
- Temperature : 26°C
- Relative Humidity : 53%
- Test Date : May. 10, 2000

11.1 Test setup

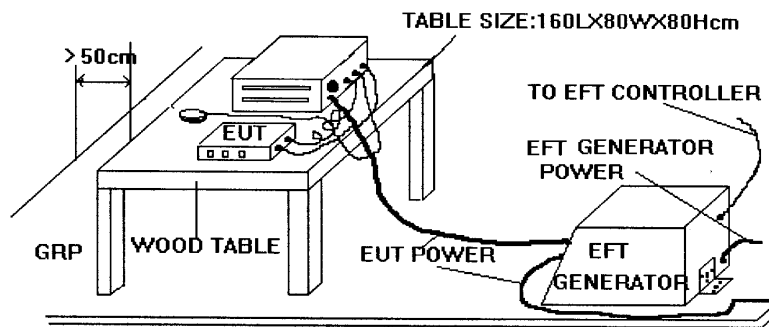

The EUT was placed on a ground reference plane and was insulated from it by an insulating support about 0.1m thick. If the EUT is table-top equipment, it was located approximately 0.8m above the GRP.. The GRP. was a metallic sheet (copper or aluminum) of 0.25 mm ,minimum thickness; other metallic may be used but they shall have at least 0.65 mm thickness. It shall project beyond the EUT by at least 0.1m on all sides and connected to the protective earth. In the SPORTON EMC LAB. we provided 1 mm thickness aluminum ground reference plane or 1 mm thickness stainless steel ground reference plane. The minimum size of the ground reference plane is 1 m x 1 m, the exact size depending on the dimensions of the EUT. It was connected to the protective grounding system. The EUT was arranged and connected according to its functional requirements. The minimum distance between the EUT and other conductive structures, except the GRP. beneath the EUT, was more than 0.5 m. Using the coupling clamp, the minimum distance between the coupling plates and all other conductive structures, except the GRP. beneath the EUT, was more than 0.5 m. The length of the signal and power lines between the coupling device and the EUT was 1m or less.

11.2 Test on Power Line

- a. The EFT/B-generator was located on the GRP.. The length from the EFT/B-generator to the EUT as not exceed 1 m.
- b. The EFT/B-generator provides the ability to apply the test voltage in a non-symmetrical condition to the power supply input terminals of the EUT.

11.3 Test on Communication Lines

- a. The coupling clamp is composed of a clamp unit for housing the cable (length more than 3 m), and was placed on the GRP..
- b. The coupling clamp provides the ability of coupling the fast transient/bursts to the cable under test.

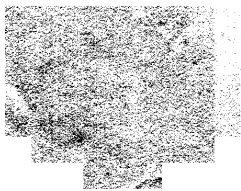

11.4 Test Procedure

- a. In order to minimize the effect of environmental parameters on test results, the climatic conditions when test is carrying out shall comply with the following requirements:
- ambient temperature: 15°C to 35°C;
 - relative humidity : 45% to 75%;
 - atmospheric pressure : 68 KPa (680 mbar) to 106 KPa (1060 mbar).
- b. In order to minimize the effect of environmental parameters on test results, the electromagnetic environment of the laboratory shall not influence the test results.
- c. The variety and diversity of equipment and systems to be tested make it difficult to establish general criteria for the evaluation of the effects of fast transients/bursts on equipment and systems.
- d. The test results may be classified on the basic of the operating conditions and the functional specification of the equipment under test, according to the following performance criteria :
- Normal performance within the specification limits.
 - Temporary degradation or loss of function or performance which is self-recoverable.
 - Temporary degradation or loss of function or performance which requires operator intervention or system reset.
 - Degradation or loss of function which is not recoverable due to damage of equipment (components).

11.5 Test Severity Levels

The following test severity levels are recommended for the fast transient/burst test :

Open circuit output test voltage $\pm 10\%$		
Level	On Power Supply	On I/O signal, data and control line
1	0.5 KV	0.25 KV
2	1.0 KV	0.50 KV
3	2.0 KV	1.00 KV
4	4.0 KV	2.00 KV
X	Specified	Specified

Remark : " X " is an open level. The level is subject to negotiation between the user and the manufacturer or is specified by the manufacturer.

Test Engineer : 
 ROXY CHOU

11.6 Photographs of Electrical Fast Transient/BURST Immunity Test

FRONT VIEW



REAR VIEW



12. Surge Immunity Test

- **Pass** performance Criteria : **A**
- Basic Standard : EN 61000-4-5 (1995)
- Generic Standard : EN 55024:1998
- Level : 3
- Input Voltage, Frequency : AC 230V, 50Hz
- Test Voltage : 2.0 KV
- Temperature : 26° C
- Relative Humidity : 54 %
- Test Date : May. 10, 2000

12.1 Test Record

Voltage (KV)	Test Point	Polarity	Phase Angle				Result
			0°	90°	180°	270°	
1KV	L - N	+	A	A	A	A	<u>PASS</u>
		-	A	A	A	A	<u>PASS</u>
2KV	L - PE	+	A	A	A	A	<u>PASS</u>
		-	A	A	A	A	<u>PASS</u>
	N - PE	+	A	A	A	A	<u>PASS</u>
		-	A	A	A	A	<u>PASS</u>

12.2 Test Level

Level	Open-circuit test voltage, ± 10%, KV
1	0.5
2	1.0
3	2.0
4	4.0
x	Specified

NOTE - x is an open class.
This level can be specified in the product specification.

12.3 Test Procedure

a. Climatic conditions

The climatic conditions shall comply with the following requirements :

- ambient temperature : 15 °C to 35 °C
- relative humidity : 10 % to 75 %
- atmospheric pressure : 86 kPa to 106 kPa (860 mbar to 1060 mbar)

b. Electromagnetic conditions

The electromagnetic environment of the laboratory shall not influence the test results.

c. The test shall be performed according the test plan that shall specify the test set-up with

- generator and other equipment utilized;
- test level (voltage/current);
- generator source impedance;
- internal or external generator trigger;
- number of tests : at least five positive and five negative at the selected points;
- repetition rate : maximum 1/min.
- inputs and outputs to be tested;
- representative operating conditions of the EUT;
- sequence of application of the surge to the circuit;
- phase angle in the case of a.c. power supply;
- actual installation conditions, for example :
 - AC : neutral earthed,
 - DC : (+) or (-) earthed to simulated the actual earthing conditions.

d. If not otherwise specified the surges have to be applied synchronized to the voltage phase at the zero-crossing and the peak value of the a.c. voltage wave (positive and negative).

e. The surges have to be applied line to line and line(s) and earth. When testing line to earth, the test voltage has to be applied successively between each of the lines and earth, if there is no other specification.

f. The test procedure shall also consider the non-linear current-voltage characteristics of the equipment under test. Therefore the test voltage has to be increased by steps up to the test level specified in the product standard or test plan.

g. All lower levels including the selected test level shall be satisfied. For testing the secondary protection, the output voltage of the generator shall be increased up to the worstcase voltage breakdown level (let-through level) of the primary protection.

- h. If the actual operating signal sources are not available, they may be simulated. Under no circumstances may the test level exceed the product specification. The test shall be carried out according to the test plan.
- i. To find all critical points of the duty cycle of the equipment, a sufficient number of positive and negative test pulses shall be applied. For acceptance test a previously unstressed equipment shall be used to the protection devices shall be replaced.

Test Engineer : 
ROXY CHOU

12.4 Photographs Of Surge Immunity Test

FRONT VIEW



REAR VIEW



13. Conducted Disturbances Induced By Radio-Frequency Field Immunity Test (CS)

- **Pass** performance Criteria : **A**
- Basic Standard : EN 61 000-4-6 (1996)
- Generic Standard : EN 55024:1998
- Input Voltage, Frequency : AC 230V, 50Hz
- Level : 2
- Test Voltage : 3 Vrms (Modulated, 1KHz, 80%, AM)
- Frequency Range : 0.15 MHz to 80 MHz
- Temperature : 24° C
- Relative Humidity : 58 %
- Test Date : May. 10, 2000

13.1 Test Level

Level	Voltage Level (EMF),
1	1 V
2	3 V
3	10 V
x	Specified
NOTE - x is an open class. This level can be specified in the product specification.	

13.2 Test Procedure

- a. The EUT shall be operated within its intended climatic conditions. The temperature and relative humidity should be recorded.
- b. This test method test can be performed without using a sell shielded enclosure. This is because the disturbance levels applied and the geometry of the setups are not likely to radiated a high amount of energy, especially at the lower frequencies. If under certain circumstances the radiated energy is too high, a shielded enclosure has to be used.
- c. The test shall be performed with the test generator connected to each of the coupling and decoupling devices in turn while the other non-excited RF-input ports of the coupling devices are terminated by a 50 ohm load resistor.
- d. Filters shall be used to prevent (higher order or sub-) harmonics form disturbing the EUT. A High-Pass Filter. 100KHz, (HPF) may be required with the test generator. The band stop

characteristics of the Low-Pass Filters (LPF) shall be sufficient to suppress the harmonics down to the immunity level required within that band. These filters shall be inserted with the test generator before setting the test level.

- e. The frequency range is swept from 150 KHz to 230 MHz, using the signal levels established during the setting process, and with the disturbance signal 80% amplitude modulated with a 1KHz sinewave, pausing to adjust the RF-signal level or to switch coupling devices as necessary. The rate of sweep shall no exceed 1.5×10^{-3} decades/s. Where the frequency is swept incrementally, the step size shall no exceed 1% of the start and thereafter 1% of the preceding frequency value.
- f. The dwell time at each frequency shall not be less than the time necessary for the EUT to be exercised, and able to respond. Sensitive frequencies e.g. clock frequency(ies) and harmonics or frequencies of dominant interest shall be analyzed separately.
- g. An alternative test procedure may be adopted, wherein the frequency range is swept incrementally, with a step size not exceeding 4% of the start ad thereafter 4% of the preceding frequency value. The test level should be at least twice the value of the specified test level.
- h. In cases of dispute, the test procedure using a step size not exceeding 1% of the start and thereafter 1% of preceding frequency value shall take precedence.
- i. Attempts should be made to fully exercise the EUT during testing, and to fully interrogate all exercise modes selected for susceptibility.
- j. The use of special exercising programs is recommended.
- k. Testing shall be performed according to a Test Plan, which shall be included in the test report.

Test Engineer :



ROXY CHOU

14. Power Frequency Magnetic Field immunity tests

- **Pass** performance Criteria : A
- Basic Standard : EN 61000-4-8 (1993)
- Generic Standard : EN 55024:1998
- Input Voltage, Frequency : AC 230V, 50Hz
- Temperature : 26 °C
- Relative Humidity : 56 %
- Test Date : May. 10, 2000

14.1 Test Record

Power Frequency Magnetic Field	Testing duration	Coil Orientation	Results	Remark
50Hz, 1A/m	1.0 Min	X-axis	Pass	Normal
50Hz, 1A/m	1.0 Min	Y-axis	Pass	Normal
50Hz, 1A/m	1.0 Min	Z-axis	Pass	Normal

14.2 Test Setup

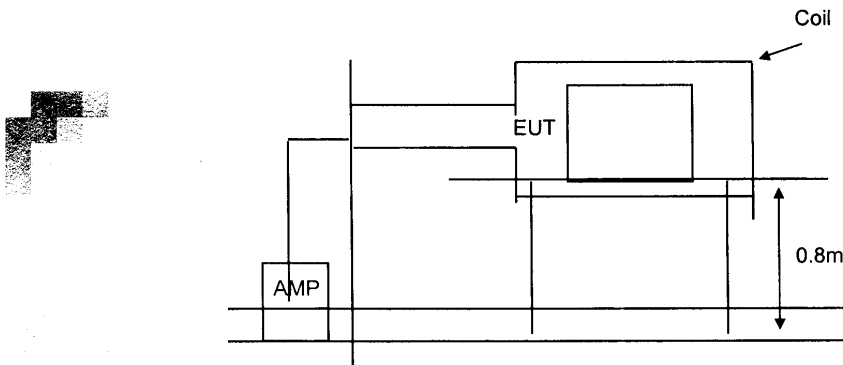

Test Engineer : *Roxy*
 ROXY CHOU

Photographs of Power Frequency Magnetic Field immunity tests

FRONT VIEW



REAR VIEW

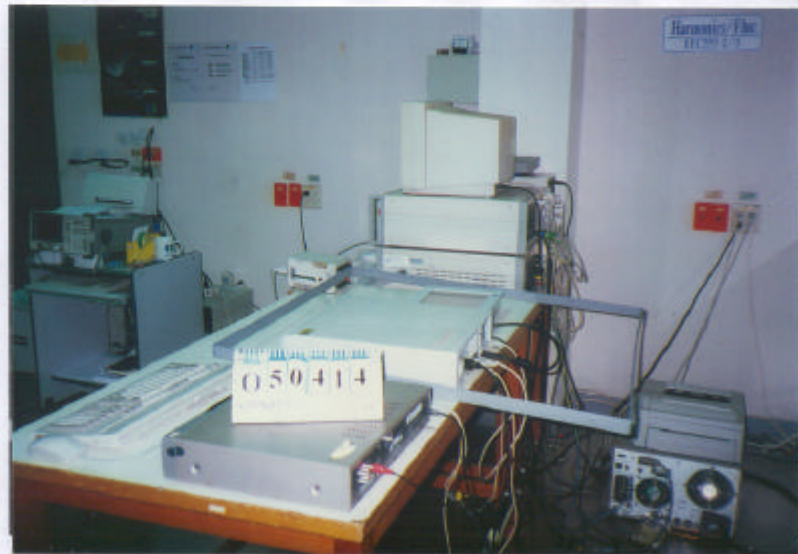

15. Voltage Dips, short interruptions and voltage variations immunity tests

- **Pass** performance Criteria : C for Voltage Interruption; A for Voltage Dips
- Basic Standard : EN 61000-4-11 (1994)
- Generic Standard : EN 55024:1998
- Input Voltage, Frequency : AC 230V, 50Hz
- Temperature : 26 °C
- Relative Humidity : 53 %
- Test Date : May. 10, 2000

15.1 Test Record Of Voltage Interruption

Voltage (V)	Phase Angle								% Reduction	ms
	0 °	45°	90°	135°	180°	225°	270°	315°		
230	C	C	C	C	C	C	C	C	> 95 %	250

15.2 Test Record Of Voltage Dips

Voltage (V)	Phase Angle								% Reduction	ms
	0 °	45°	90°	135°	180°	225°	270°	315°		
230	A	A	A	A	A	A	A	A	30	25
230	A	A	A	A	A	A	A	A	> 95 %	0.5

15.3 Testing Requirement And Procedure

The test was based on EN 61000-4-11 (1994) and EN 55024:1998.

15.4 Information of cables

Power cable : unshielded power cable.

15.5 Test conditions

1. Source voltage and frequency : 230V / 50Hz, Single phase.
2. Phase shifting : 0, 45, 90, 135, 180, 225, 270, 315 degrees.
3. Test of interval : 10 sec.
4. Level and duration : Sequency of 3 dips/interrupts.
5. Voltage rise (and fall) time : 1 ~ 5 μ s.
6. Test severity :

Voltage dip and Interrupt reduction (%)	Test Duration (ms)
30	500
60	100
100	10
100	80
100	5000

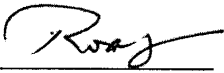
Test Engineer : 

ROXY CHOU

15.6 Photographs Of Voltage Dips, Short Interruptions And Voltage Immunity Tests

FRONT VIEW



REAR VIEW



16. Antenna Factor & Cable Loss

Frequency (MHz)	Antenna Factor (dB)	Cable Loss (dB)
30	17.0	0.6
35	16.3	0.6
40	12.6	0.7
45	12.4	0.8
50	10.4	0.8
55	8.4	0.8
60	6.4	0.9
65	6.4	0.9
70	6.4	1.0
75	6.7	1.0
80	7.1	1.0
85	7.5	1.1
90	7.8	1.1
95	9.3	1.0
100	10.7	1.1
110	11.9	1.1
120	12.9	1.2
130	12.6	1.3
140	12.2	1.3
150	11.4	1.4
160	9.5	1.4
170	9.8	1.4
180	9.7	1.5
190	9.5	1.5
200	9.3	1.5
220	10.7	1.6
240	12.0	1.6
260	13.0	1.8
280	13.7	1.8
300	14.4	2.0
320	14.9	2.1
340	15.3	2.1
360	15.8	2.2
380	16.3	2.2
400	16.7	2.3
450	17.0	2.5
500	17.3	2.5
550	18.5	2.6
600	19.7	2.7
650	19.2	2.9
700	18.7	3.2
750	19.3	3.3
800	19.9	3.4
850	21.2	3.6
900	22.4	3.8
950	21.7	3.9
1000	20.9	4.0

LKOP3

17. List of Measuring Equipment Used

(EMI)

Instrument	Manufacturer	Model No.	Serial No.	Characteristics	Calibration Date	Remark
EMC Receiver (site 2)	HP	8591EM	3710A01187	9 KHz - 18 GHz	Sep. 06. 1999	Conduction
LISN (Support Unit) (site 2)	Telemeter	NNB-2/16Z	98009	50 ohm / 50 uH	Dec. 06. 1999	Conduction
LISN (EUT) (site 2)	Telemeter	NNB-2/16Z	98087	50 ohm / 50 uH	Dec. 06. 1999	Conduction
Quasi-peak Adapter (site 3)	HP	85650A	2811A01116	9KHz -1GHz	Jun. 20. 1999	Radiation
Amplifier (Site 3)	HP	8447D	2944A09068	0.1MHz -1.3GHz	Sep. 02. 1999	Radiation
Spectrum Analyzer (site 3)	HP	8568B	2732A04100	100Hz - 1.5GHz	Jun. 20. 1999	Radiation
Bilog Antenna (Site 3)	CHASE	CBL6112A	2320	30MHz -2GHz	Sep. 08. 1999	Radiation
Half-wave dipole antenna (Site 3)	EMCO	3121C	9705-1285	28M - 1GHz	May 18. 1999	Radiation
Turn Table (site 3)	EMCO	2080	9711-2022	0 ~ 360 degree	N/A	Radiation
Antenna Mast (site 3)	EMCO	2075	9710-2101	1 m- 4 m	N/A	Radiation

(EMS)

Instrument	Manufacturer	Model No.	Characteristics	Calibration Date	Remark
ESD Simulator	KEYTEK	MZ-15/EC	0 KV - 15 KV	Apr. 17, 2000	ESD
OMNI-Tip	KEYTEK	TPC-2	0 KV - 15 KV	Jul. 23, 1999	ESD
Amplifier	AR	100W 1000M3	80 MHz - 1 GHz	N/A	RS
Isotropic Field Probe	AR	FP3000A	10 KHz - 1 GHz	Jun. 19, 1999	RS
IEEE-488 Interface	AR	CP3000	N/A	N/A	RS
System Interface	EMC Automation	200	HP-IB INTERFACE	N/A	RS
Power Meter	EMC Automation	438A	100 KHz - 4.2 GHz	N/A	RS
Video Camera controller	EMC Automation	VCC-01	N/A	N/A	RS
Signal Generator	HP	8648A	100 KHz - 1 GHz	Sep. 10, 1999	RS
Signal Generator	R&S	SMX	100 KHz - 1 GHz	Nov. 07, 1999	RS
Antenna	CHASE	CBL6121A	26 MHz - 1 GHz	Jun. 12, 1999	RS
Amplifier	AR	75W 75A220	25MHz - 300MHz	Jun. 14, 1999	RS
EFT Generator	KEYTEK	CE-40	0 KV - 4.4 KV	Jul. 09, 1999	EFT
Capacitive Clamp	KEYTEK	CE-40-CCL	0 KV - 2 KV	Jun. 23, 1999	EFT
Harmonic/Flicker Test System	HP	6843A	4800VA 90A / 48A PEAK	Nov. 15, 1999	Harmonics, Flicker
Combination Wave Generator	EMC PARTNER AG Switzerland	MIG0603IN2	6 KV, 3 KA	Feb. 05, 2000	SURGE
Conducted Immunity Test System	FRANKONIA	CIT-10/W	100KHz ~ 266MHz	Jan. 10, 2000	CS
Magnetic field Antenna	EMC PARTNER	MF-1000	0.5 up to 150A / m	Feb. 02. 2000	Magnetic
EMC Immunity Tester	EMC PARTNER AG Switzerland	TRANSIENT 1000	0 ~ 260 rms, 16A	Feb. 02, 2000	DIP

18. Notice for Class A Product

Class A ITE is a category of all other ITE which satisfies the class A ITE limits but not the class B ITE limits. Such equipment should not be restricted in its sale but the following warning shall be included in the instructions for use:

Warning

This is a class A product. In a domestic environment this product may cause radio interference in which case the user may be required to take adequate measures.



19. Declaration of Conformity and the CE Mark

There are three possible procedures pertaining to the declaration of conformity :

19.1 Conformity Testing and Declaration of Conformity by the Manufacturer or His Authorized Representative Established within the Community or by an Importer.

- Article 10 (1) of the EMC Directive,
- § 3 (1) no. 2a of the EMC Act.

19.2 Declaration of Conformity Issued by the Manufacturer or His Authorized Representative Established within the Community or by an Importer Following Testing of the Product and Issued of an EC certificate of conformity by a competent body.

- Article 10 (2) of the EMC Directive,
- § 3 (1) no. 2b of the EMC Act.

19.3 Declaration of Conformity Issued by the Manufacturer or His Authorized Representative Established within the Community or by an Importer Following Testing and Certification of the Product by a Notified Body.

- Article 10 (5) of the EMC Directive,
- § 3 (1) no. 2b of the EMC Act (radio transmitting installations).

19.4 Specimen For The CE Marking Of Electrical / Electronical Equipment

The components of the CE marking shall have substantially the same vertical dimension, which may not be less than 5 mm.

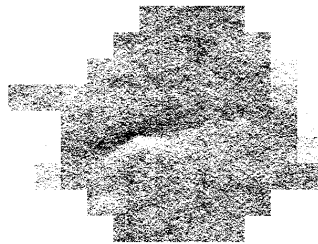

APPENDIX A. Photographs of EUT



050414-01.jpg



050414-02.jpg

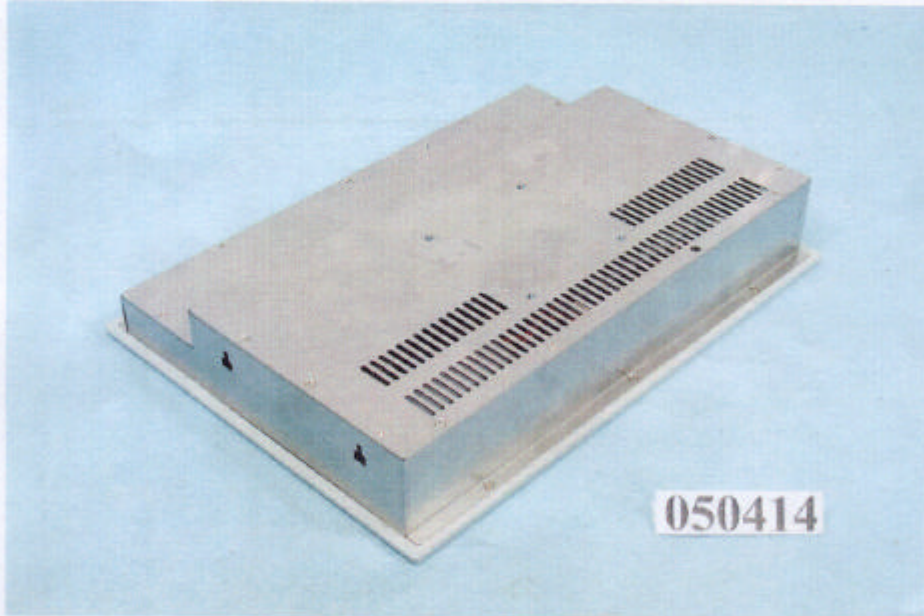

050414-03.jpg

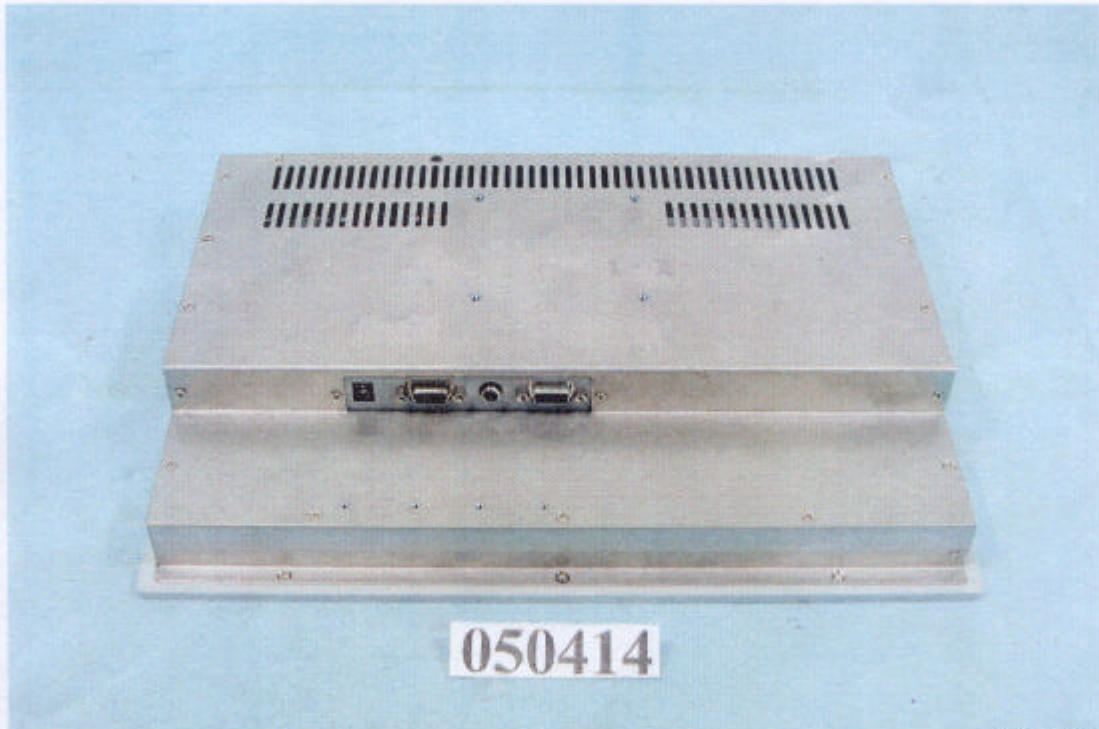

050414-04.jpg

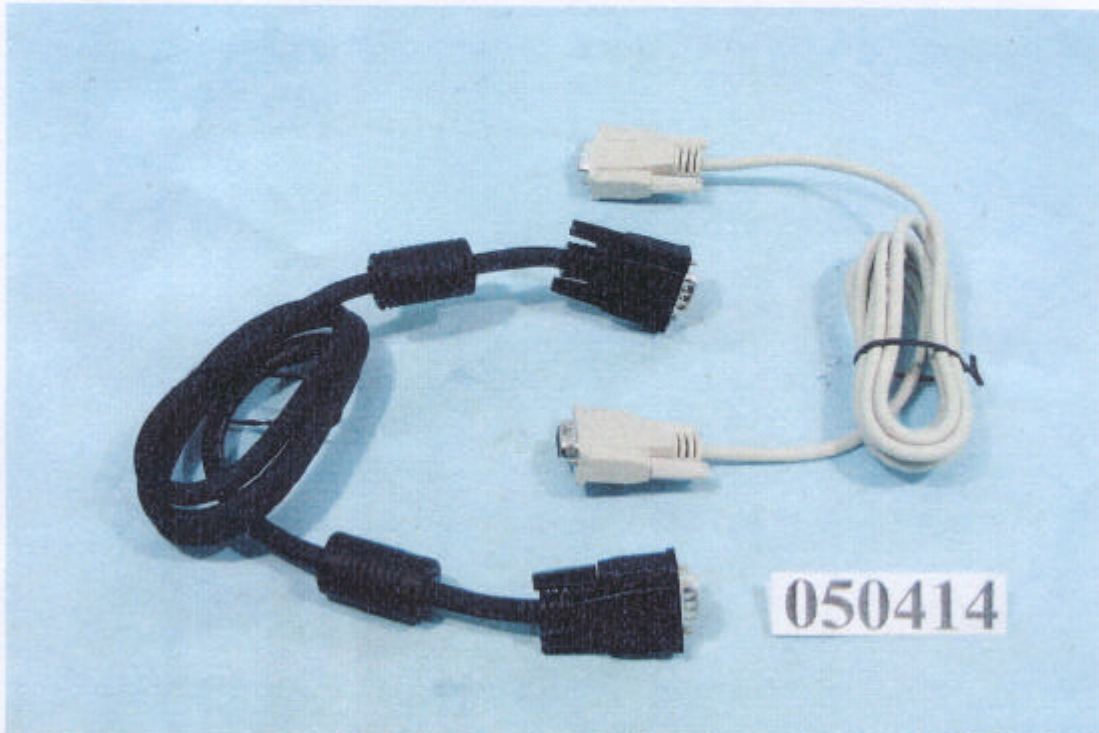

050414-05.jpg



050414-06.jpg



050414-07.jpg