

Statement of Conformity

Best Laboratory Co., Ltd.

No. 336, Ba Lian RD., Sec. 1, Hsi Chih City, Taipei Hsien, Taiwan, R.O.C.
Telephone: 886-2-2646-2899 Facsimile: 886-2-2646-2870

EMC Certificate

Applicant : AAEON Technology Inc.
Address : 5F, No.135, Lane 235, Pao Chiao Road,
Hsin-Tien City, Taipei, Taiwan, R.O.C
Equipment : Panel PC
Model : AMB-2051HT, AMB-2051HTT,
AMB-2021HT, AMB-2021HTT

Has fully complied with the requirements set out in the council directive on the approximation of the law of the members states relating to Electromagnetic Compatibility Directive (89/336/EEC). For the evaluation regarding EMC, the following standards were applied:

EMI: EN 50081-2:1993 -> EN 55022:1998, EN 61000-3-2:1998,
EN 61000-3-3:1995

EMS: EN 55024:1998 -> EN 61000-4-2:1998, EN 61000-4-3:1998,
EN 61000-4-4:1995, EN 61000-4-5:1995,
EN 61000-4-6:1996, EN 61000-4-8:1993,
EN 61000-4-11:1994, EN 61000-6-2:1999

The date of the measurement: Jan 18, 2001
The date of the certification signed: Jan 18, 2001
The number of EMC Certificate: CER-A06-CE-158

Test Laboratory



Quality Department Manager: JEFF CHIU



This verification is based on a single evaluation of one sample of above-mentioned products. It does not imply any assessment of the whole production and does not permit the use of the logo of the test laboratory.

EMC TEST REPORT

Applicant : AAEON Technology Inc.
Equipment : Panel PC
Model : AMB-2051HT, AMB-2051HTT,
AMB-2021HT, AMB-2021HTT

Test Report Certification

Best Laboratory Co., Ltd.

No. 336, Ba Lian Rd., Sec. 1, Hsi Chih City, Taipei Hsien, Taiwan, R.O.C.
Tel: 886-2-2646-2899 Fax: 886-2-2646-2870

Applicant : AAEON Technology Inc.
Address : 5F, No.135, Lane 235, Pao Chiao Road,
Hsin-Tien City, Taipei, Taiwan, R.O.C.
Equipment : Panel PC
Model : AMB-2051HT, AMB-2051HTT,
AMB-2021HT, AMB-2021HTT
Device's Class : Class A Device
Measurement Standard : EN 50081-2/1993, EN 55024/1998
Measurement Procedure : EN 55022/1998, EN 61000-3-2/1998, EN 61000-3-3/1995,
EN 61000-4-2/1998, EN 61000-4-3/1998, EN 61000-4-4/1995,
EN 61000-4-5/1995, EN 61000-4-6/1996, EN 61000-4-8/1995,
EN 61000-4-11/1995, EN 61000-6-2/1999
Operating Voltage : 230VAC, 50Hz
Test Result : **Compliance** (Detail showed in the test report)
Sample Received : Jan 05, 2001
Test Date : Jan 18, 2001
Report Number : RE-A06-CE-158
Test Firm : No. 336, Ba Lian Rd., Sec. 1,
Hsi Chih City, Taipei Hsien, Taiwan, R.O.C.

Remark:

- (1) The test report is only relating to the sample tested
- (2) The test report shall not be reproduced except in full, without the written approval of Best Laboratory Co., Ltd.

Prepared : 
ANN HUNG

Approved :  (Title: Quality Department Manager)
JEFF CHIU

Date Issued : 

Contain

1	General Information	
1.1	EUT Description.....	4
1.2	Test System Detail.....	5
1.3	Tested Configuration.....	6
1.4	EUT Exercise Software.....	7
1.5	Test Performed.....	7
2	Conducted Emission Measurement	
2.1	Test Equipment List.....	8
2.2	Test Set-Up.....	8
2.3	Limit	8
2.4	Test Procedure.....	9
2.5	Test Specification.....	9
2.6	Test Result.....	9
3	Radiated Emission Measurement	
3.1	Test Equipment List.....	10
3.2	Test Set-Up.....	10
3.3	Limit.....	11
3.4	Test Procedure.....	11
3.5	Test Specification.....	11
3.6	Test Result.....	11
4	Power Harmonic and Voltage Fluctuation	
4.1	Power Harmonic and voltage Fluctuation test Equipment List.....	12
4.2	Test Set-Up.....	12
4.3	Limit.....	12
4.4	Test Procedure.....	13
4.5	Test Specification.....	13
4.6	Test Result.....	13
5	Electrostatic Discharge (ESD)	
5.1	Test Equipment List.....	14
5.2	Test Set-Up.....	14
5.3	Test Level.....	14
5.4	Test Procedure.....	15
5.5	Test Specification.....	15
5.6	Test Result.....	15
6	Radiated Susceptibility (RS)	
6.1	Test Equipment List.....	16
6.2	Test Set-Up.....	16
6.3	Test Level.....	16
6.4	Test Procedure.....	17
6.5	Test Specification.....	17
6.6	Test Result.....	17
7	Electrical Fast Transient/Burst	
7.1	Test Equipment List.....	18
7.2	Test Set-Up.....	18
7.3	Test Level.....	18
7.4	Test Procedure.....	19
7.5	Test Specification.....	19
7.6	Test Result.....	19

8 Surge	
8.1 Test Equipment List.....	20
8.2 Test Set-Up.....	20
8.3 Test Level.....	20
8.4 Test Procedure.....	21
8.5 Test Specification.....	21
8.6 Test Result.....	21
9 Conducted Susceptibility	
9.1 Test Equipment List.....	22
9.2 Test Set-Up.....	22
9.3 Test Level.....	23
9.4 Test Procedure.....	23
9.5 Test Specification.....	23
9.6 Test Result.....	23
10 Power Frequency Magnetic Field	
10.1 Test Equipment List.....	24
10.2 Test Set-Up.....	24
10.3 Test Level.....	24
10.4 Test Procedure.....	25
10.5 Test Specification.....	25
10.6 Test Result.....	25
11 Voltage DIPS and Interruption Measurement	
11.1 Test Equipment List.....	26
11.2 Test Set-Up.....	26
11.3 Test Level.....	26
11.4 Test Procedure.....	27
11.5 Test Specification.....	27
11.6 Test Result.....	27
12 Modification List	
13 Appendix	
Appendix A: Summary of Test Result.....	30
Appendix B: The Photograph of measurement.....	42
Appendix C: The Detail Photograph of EUT.....	49

1. General Information

1.1 EUT Description

Applicant : AAEON Technology Inc.

Address : 5F, No.135, Lane 235, Pao Chiao Road,
Hsin-Tien City, Taipei, Taiwan, R.O.C.

Equipment : Panel PC

Model : AMB-2051HT, AMB-2051HTT,
AMB-2021HT, AMB-2021HTT

Device's Class : Class A Device

Operation Voltage : 230VAC, 50Hz

Output Ports :

- PS/2 Keyboard : connect with a PS/2 keyboard which data cable is 120cm long, non-shielded, no ferrite bead.
- PS/2 Mouse : connected with A PS/2 mouse which data cable is 120cm long, non-shielded, no ferrite bead.
- Serial # 1 Port : connected with a external modem via one RS-232 cable that is 70cm long, non-shielded, no ferrite bead.
- Serial # 2 Port : connected with one RS-232 cable, which is 70cm long, non-shielded, no ferrite bead, left unterminal.
- Serial # 3 Port : connected with one RS-232 cable, which is 70cm long, non-shielded, no ferrite bead, left unterminal.
- Parallel Port : connected with one printer which data cable is 120cm long, shielded, no ferrite bead.
- VGA Port : via one 120cm long, shielded, with ferrite bead, data cable to the monitor.
- USB Ports : each one of the two USB ports is connected with one USB mouse which data cable is 120 cm long, shielded, no ferrite bead.
- Microphone Port : connected with one earphone set which data cable is 1.9 meters long, non-shielded, no ferrite bead.
- Line-Out Port : connected with one earphone set which data cable is 1.9 meters long, non-shielded, no ferrite bead.
- Line-In Port : connected with one walkman which data cable is 1.8 meters long, shielded, no ferrite bead
- LAN Port : via one RJ-45 cable, 25 meters long, non-shielded, no ferrite bead, to one LAN card installed in one PC located in far-end.
- Power Port : via a 180 cm long, non-shielded, no ferrite bead, power Cable to the AC power source.

1.2 Test System Detail

Monitor : HITACHI
Model No. : CM771U
Serial No. : V0E001074
FCC ID : DoC Approval
BSMI : 3882A707
Power Type : 100-240VAC, 50/60Hz, 1.5A, Switching
Power Cord : 180cm long, non-shielded, no ferrite bead.
Data Cable : 120cm long, shielded, with ferrite bead
Backshell : Metal
Connected Port : VGA Port

Keyboard : HP (Pavilion)
Model No. : SK-2506
Serial No. : C0006002889
FCC ID : DoC Approval
檢磁 : 3882A375
Power Type : By PC
Data Cable : 180cm long, shielded, no ferrite bead
Backshell : Metal
Connected Port : PS/2 Keyboard Port

Mouse : AT Tech
Model No. : OK-520
Serial No. : 990707032; 99070046
FCC ID : DoC Approval
BSMI : 3872B356
Power Type : By PC
Data Cable : 120cm long, non-shielded, no ferrite bead
Backshell : Metal
Connected Port : PS/2 Mouse Port

Modem : ACEEX
Model No. : XDM-9624
Serial No. : 0017884
FCC ID : IFAXDM-9624
Power Type : 230VAC, 50Hz / 9VAC, 1A
Power Core : 1.9meters long, non-shielded, no ferrite bead
Data Cable : RS232, shielded, 1.2meters long, no ferrite bead
RJ11C x 2, 7' long, non-shielded, no ferrite bead
Backshell : Metal
Connected Port : Serial #1 Port

Printer : Epson

Model No. : P950
Serial No. : BW9Y113923
FCC ID : DoC Approval
BSMI : 3872P001
Power Type : 230VAC, 50Hz, 0.4A
Power Core : 165cm long, non-shielded, no ferrite bead
Data Cable : 120cm long, shielded, no ferrite bead
Backshell : Metal
Connected Port : Parallel Port

USB Mouse : Logitech

Model No. : M-BB48
Serial No. : LZE92250126, LZE92250247
FCC ID : DoC Approval
BSMI : 4872A221
Power Type : By PC
Data Cable : 120cm long, shielded, no ferrite bead
Backshell : Metal
Connected Port : USB Ports

Walkman : KOKA

Model No. : KW-250
Serial No. : N/A
FCC ID : DoC Approval
Power Type : 9VDC
Data Cable : 120cm long, shielded, no ferrite bead
Backshell : Metal
Connected Port : Line-in Port

Earphone set : KOKA

Model No. : MS-321
Serial No. : N/A
FCC ID : DoC Approval
Data Cable : 145cm long, non-shielded, no ferrite bead
Backshell : Metal
Connected Port : Microphone & Line-Out Port

1.3 EUT Configuration

- (1) The power port of EUT is connected with the AC power source via a power cable.
- (2) The PS/2 keyboard port of EUT is connected with a PS/2 keyboard.
- (3) The PS/2 mouse port of EUT is connected with a PS/2 mouse.
- (4) The parallel port of EUT is connected with a printer.
- (5) The serial #1 port of EUT is connected with an external modem.
- (6) The serial #2 ~ #3 port of EUT are each connected with an RS-232 cable left unterminal.
- (7) The VGA port of EUT is connected with a monitor.
- (8) The LAN port of EUT is connected with a LAN card installed in one PC located in far-end via one HUB.
- (9) Each one of the two USB ports is connected with one USB mouse.
- (10) The Line-In port of EUT is connected with one Walkman.
- (11) The microphone and Line-Out port is connected with one earphone set.

(***PS: Please refers to the Photograph***)

Drawing of Configuration

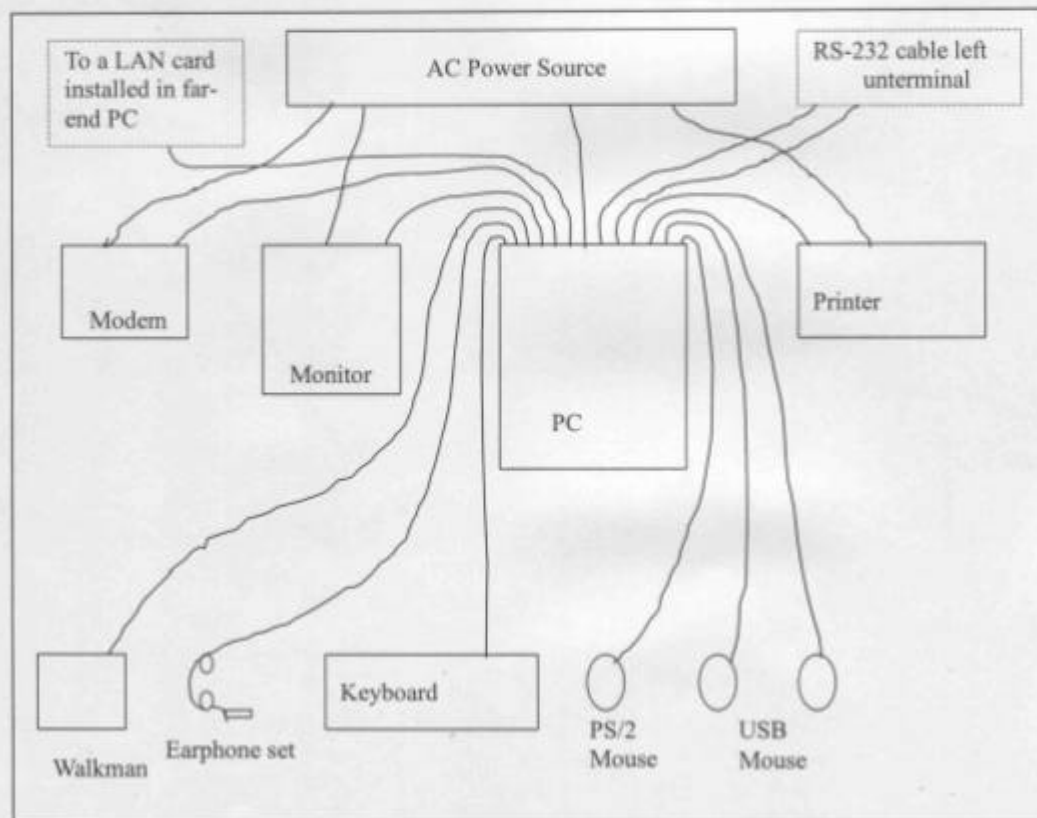

1.4 EUT Exercise Software

The testing software is provided by the applicant.

It is designed to exercise the EUT in a manner similar to a typical use. The software will send an "H" pattern to the monitor and the "H" pattern will be shown on the monitor. It would be also sent to the parallel port and the printer will print out the "H" pattern. At the same time, the mouse and keyboard will be in continuously self-test mode and responded to the EUT. The LAN port will be continuous to receive and transmit the data, The LAN card will be continuous to receive and transmit the data to the LAN port. The Walkman will be continuous to transmit the sound to the EUT. The software will enable all functions of EUT.

1.5 Test Performed

Conducted emissions were investigated over the frequency range from 0.15MHz to 30MHz using a receiver which bandwidth is set at 9KHz.

Radiated emissions were investigated over the frequency range from 30MHz to 1000MHz using a receiver which bandwidth is set at 120KHz. Radiated measurement was performed at distance that from an antenna to EUT is 10 meters.

The testing result of pretest was shown out that the "Testing" mode is worse than the "Standby" mode. So, the final measurement was made on the "Testing" mode.

When the measurement was taken, there are three video resolution modes tested: 400 * 800, 640 * 480, 1024 * 768.

2 Conducted Emission Measurement

2.1 Test Equipment

No.	Instrument	Manufacture	Model	Serial No.	Last Calibrate
1.	LISN (EUT)	Rolf Heine	NNB-2/16Z	99084	Dec. 14, 1999
2.	LISN (AXE)	Rolf Heine	NNB-2/16Z	99086	Dec. 14, 1999
3.	EMI Receiver	Rohde & Schwarz	ESI 7	830154/001	Nov. 22, 1999
4.	50Ω Terminator	Amphenol	46650-51	N/A	Mar. 10, 2000
5.	RF Cable	Belden	M17/158	MIL-C-17	Jan. 20, 2000

Remark: All equipment upon which need to calibrated are with calibration period of 1 year.

2.2 Test Set-Up

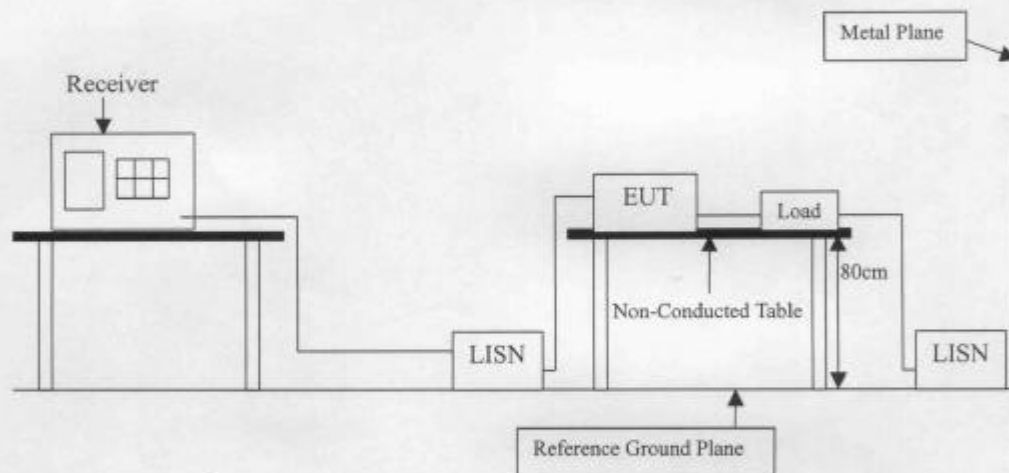

2.3 Limit

Frequency	Limit (dB μ V)			
	Class A		Class B	
	Quasi Peak	Average	Quasi Peak	Average
MHz				
0.15 ~ 0.50	79	66	66 ~ 56	56 ~ 46
0.50 ~ 5.0	73	60	56	46
5.0 ~ 30.0	73	60	60	50

Remark: In the above table, the tighter limit applies at the band edges.

2.4 Test Procedure

The EUT and simulators are connected to the main power through a line impedance stabilization network (LISN). It provides a 50 ohm / 50 μ H coupling impedance for the measuring equipment. The peripheral devices are also connected to the main power through a LISN that provides a 50 ohm / 50 μ H coupling impedance with 50 ohm termination. (Please refers to the block diagram of the test setup and photograph.)

Both sides of AC line are checked for the maximum conducted emission interference. In order to find the maximum emissions, the relating positions of equipment and all of the interference cables must be changed according to EN 55022/1998 regulation: The measurement procedure on conducted emission interference.

The resolution bandwidth of the field strength meter (Rohde & Schwarz) is set at 9KHz.

2.5 Test Specification

According to the EN 55022/1998

2.6 Test Result

The emissions that come from the EUT were below the specified limits. The worst case of conducted emissions measurement are shown in the appendix A. The acceptance criterion was met and the EUT has pass the measurement.

3. Radiated Emission Measurement

3.1 Test Equipment List

No.	Instrument	Manufacture	Model	Serial No.	Last Calibrate
1.	Antenna	Mess-Elektronik	VULB 9160	9160-3078	Jan. 19, 2000
2.	EMI Receiver	Rohde & Schwarz	ESI 7	830154/001	Nov. 22, 1999
3.	RF Cable	Adventest	AD-N-CA-01	2000-0220	Apr. 01, 2000
4.	OATS	Bestlab	N/A	OATS#1	Mat 30, 2000

Remark: All equipment upon which need to calibrated are with calibration period of 1 year.

3.2 Test Setup

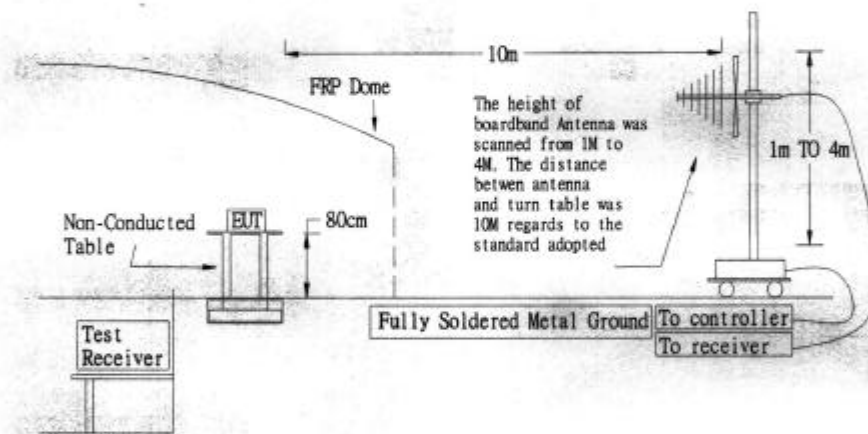

3.3 Limit

Frequency MHz	Class A		Class B	
	Distance (Meter)	Limit (dB μ V)	Distance (Meter)	Limit (dB μ V)
30 ~ 230	10	40	10	30
230 ~ 1000	10	47	10	37

Remark: In the above table, the tighter limit applies at the band edges

3.4 Test Procedure

The EUT and its simulators are placed on turn table, non-ducted and wooden, which is 0.8 meter above ground. The turn table rotates 360 degree to determine the position of the maximum emission level. The EUT was positioned such that distance from antenna to the EUT is 10 meters.

The antenna is moved up and down between 1 meter to 4 meter to receive the maximum emission level.

Both horizontal and vertical polarization of the antenna are set on measurement. In order to find the maximum emission, all of the interference cables must be manipulated according to EN 55022/1998 regulation: the test procedure of the radiated emission measurement.

The bandwidth set on the field strength is 120KHz when the frequency range is below 1GHz

3.5 Test Specification

According to EN 55022/1998

3.6 Test Result

The emissions that come from the EUT were below the specified limits. The worst case of conducted emissions measurement are shown in the appendix A. The acceptance criterion was met and the EUT has pass the measurement.

4. Power Harmonic and Voltage Fluctuation Measurement

4.1 Power Harmonic and Voltage Fluctuation Test Equipment List

No.	Instrument	Manufacture	Model	Serial No.	Last Calibrate
1.	H/F Test System	EMC Partner	Harmonic-1000	325807	Jun. 10, 2000

Remark: All equipment upon which need to calibrated are with calibration period of 1.5 year.

4.2 Test Setup

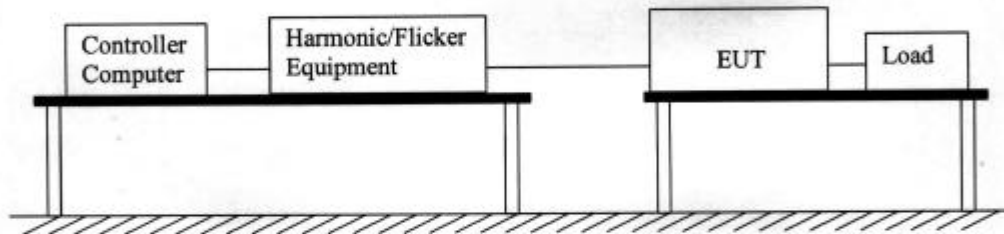

4.3 Limit of Harmonic Current

Limit of Harmonic Currents

Harmonic Order	Maximum Permissible Harmonic Current (Ampere)	Harmonic Order	Maximum Permissible Harmonic Current (Ampere)
Odd Harmonic		Even Harmonic	
3	2.30	2	1.08
5	1.14	4	0.43
7	0.77	6	0.30
9	0.40	$8 \leq n \leq 40$	$0.23 \times 8/n$
11	0.33		
13	0.21		
$15 \leq n \leq 39$	$0.15 \times 15/n$		

4.4 Test Procedure

The EUT is supplied in series with power analyzer from a power source has the same normal voltage and frequency as the rated supply voltage and the equipment under test. The rated voltage at the supply voltage of EUT of 0.94 times and 1.06 times shall be performed.

4.5 Test Specification

According to EN 61000-3-2/1998, EN 61000-3-3/1995

4.6 Test Result

The measurement of the power harmonics, which test at the extremes of EUT's supply range, was investigated and the test result was shown on the Appendix A. The acceptance criterion was met and the EUT has pass the measurement.

5. Electrostatic Discharge (ESD)

5.1 Test Equipment List

No.	Instrument	Manufacture	Model	Serial No.	Last Calibrate
1.	ESD Emulator	Noiseken	ESS-100L	0199C02380	Feb. 02, 2000

Remark: All equipment upon which need to calibrated are with calibration period of 1.5 year.

5.2 Test Setup

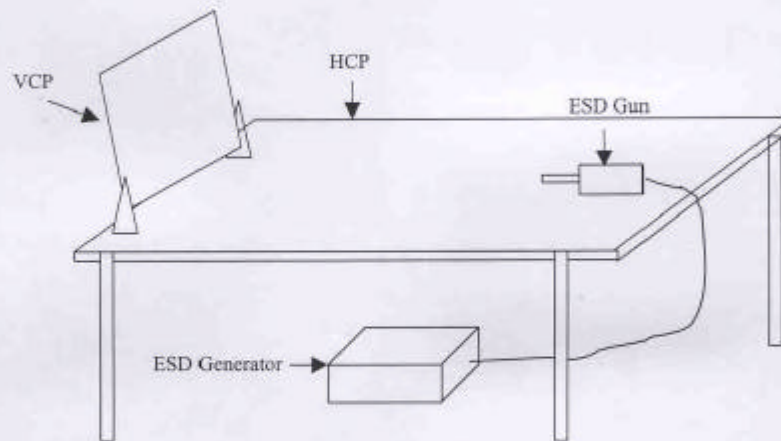

5.3 Test Level

Item	Environment	Unit	Test Specification	Performance Criteria
Enclosure Room		KV(Charge Voltage)		B
	Electrostatic Discharge		8 (Air Discharge) 4 (Contact Discharge)	

5.4 Test Procedure

Direct applicant of discharge to the EUT:

Contact discharge was applied only to the conducted surfaces of the EUT.

Air discharge was applied only to the non-conductive surfaces of the EUT.

When the measurement was taken, The ESD discharger was performed in single discharge. For the single discharge time between successive single discharges will keep on one second. It was at least ten single discharges with positive and negative at the same selected pointed. The selected pointed, which was performed with electrostatic discharge, was marked on the red label on the EUT.

Indirect applicant of discharge to the EUT:

Vertical Coupling Plane (VCP)

The coupling plane, of dimensions 0.5m x 0.5m, is placed parallel to, and positioned at a distance 0.1m from, the EUT, with the discharge electrode touching the coupling plane.

The four faces of the EUT will be performed with electrostatic discharge. It was at least ten single discharges with positive and negative at the same selected point.

Horizontal Coupling Plane (HCP)

The coupling plane is placed under the EUT. The generator shall be positioned vertically at a distance of 0.1m from the EUT, with the discharge electrode touching the coupling.

The four faces of the EUT will be performed with electrostatic discharge. It was at least ten single discharges with positive and negative at the same selected pointed.

5.5 Test Specification

According to EN 61000-4-2/1998

5.6 Test Result

The measurement of the electrostatic discharge was investigated and the test result was shown on the Appendix A. The acceptance criterion was met and the EUT has passed the measurement.

6. Radiated Susceptibility (RS)

6.1 Test Equipment List

No.	Instrument	Manufacture	Model	Serial No.	Last Calibrate
1.	Signal Generator	Rohde & Schwarz	SMY 02	845069/018	May 02, 1999
2.	Amplifier	Amplifier Research	100W1000M1A	20638	May 01, 1999
3.	Field Monitor	Amplifier Research	FM 2000	20391	Mar. 03, 1999

Remark: All equipment upon which need to calibrated are with calibration period of 1.5 year.

6.2 Test Setup

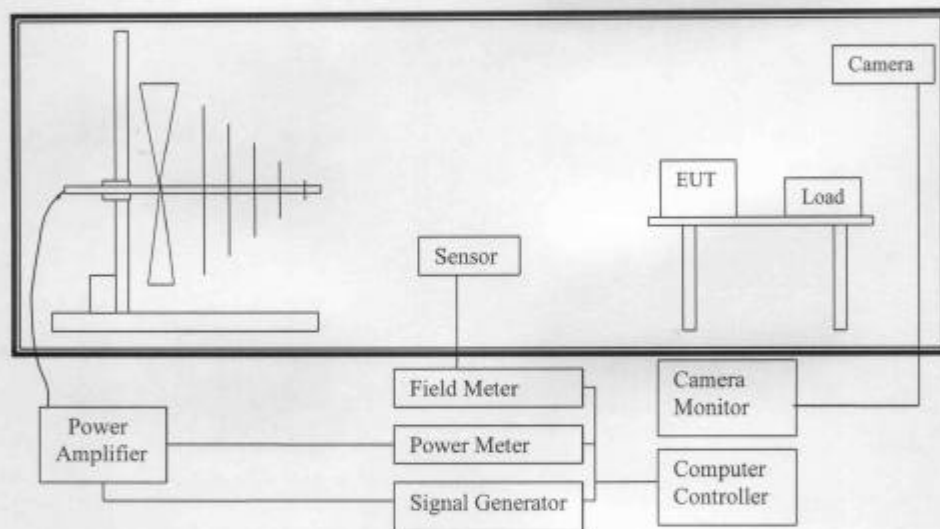

6.3 Test Level

Item	Environment	Unit	Test Specification	Performance Criteria
Enclosure Room	Radio - Frequency	MHz	80 ~ 1000	A
	Electromagnetic Field	V/m (unmodulated, rms)	10	
	Amplitude Modulated	%AM (1KHz)	80	

6.4 Test Procedure

The EUT and load, which are placed on a wooden table that the height is 0.8 meter above ground, are placed with one coincident with the calibration plane such that the distance from antenna to the EUT is 3 meters.

Both horizontal and vertical polarization of the antenna position and four sides of the EUT are set on measurement.

In order to judge the EUT performance, a CCD camera is used to monitor the situation of EUT.

All the scanning conditions are as follows:

Condition of Test	Remarks
EN 61000-4-3/1998	
1. Field Strength	10V/M; Level 3
2. Radiated Signal	AM 80% modulated with 1KHz
3. Scanning Frequencies	80MHz ~ 1000MHz
4. Dwell Time	3 seconds
5. Frequency step size Δf	1%
6. The rate of swept of frequency	1.5×10^{-3} decades/s

***** The above measurement was performed in HomeTek Technology Inc. *****

6.5 Specification

According to EN 61000-4-3/1998

6.6 Test Result

The measurement of the radiated susceptibility was investigated and the test result was shown on the appendix A. The acceptance criterion was met and the EUT has passed the measurement.

7 Electrical Fast Transient/Burst (EFT/B)

7.1 Test Equipment List

No.	Instrument	Manufacture	Model	Serial No.	Last Calibrate
1.	EMC Test System	EMC Partner	Transient-1000	TR1000-341	Aug. 25, 1999
2.	Absorbing Clamp	EMC Partner	Transient-1000	CNEFT1000-176	Aug. 25, 1999

Remark: All equipment upon which need to calibrated are with calibration period of 1.5 year.

7.2 Test Setup

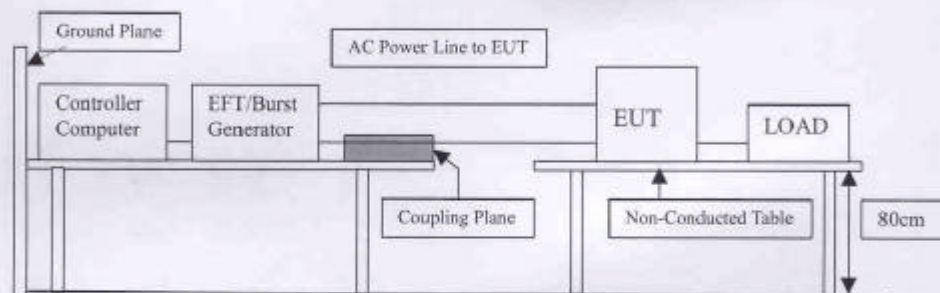

7.3 Test Level

Item	Environment	Unit	Test Specification	Performance Criteria
Ports for signal Lines and Control Lines				B
Fast Transients Common Mode		KV (Peak)	1	
		Tr/Ts (ns)	5/50	
		Rep. Frequency (KHz)	5	
DC Input and DC Output Power Ports				B
Fast Transients Common Mode		KV (Peak)	2	
		Tr/Ts (ns)	5/50	
		Rep. Frequency (KHz)	5	
Input and Output AC Power Ports				B
Fast Transients Common Mode		KV (Peak)	2	
		Tr/Ts (ns)	5/50	
		Rep. Frequency (KHz)	5	
Functional Earth Ports				B
Fast Transients Common Mode		KV (Peak)	1	
		Tr/Ts (ns)	5/50	
		Rep. Frequency (KHz)	5	

7.4 Test Procedure

The EUT and load are placed on a wooden table that is 0.8meter height above a metal ground plane dimension is 1m x 1m and thickness is at least 0.2mm. It also projected beyond the EUT by at lease 0.1meter on all sides.

For Input and Output AC power or DC Input and DC Output Power Ports:

The EUT is connected with the power mains through a coupling device that directly couples the EFT interference signal.

Each of the line and nature conductors is impressed with burst noise for 1 minute.

For Functional Earth Port:

The EUT is connected to the power mains through a coupling device that directly couples the EFT interference signal.

The protective earth line (PE) is impressed with burst noise for 1 minute.

The length of power cord between the coupling device and the EUT shall be 1 meter. For signal Lines and Control Lines Test:

The EFT interference signal is through a coupling clamp device couples to the signal and controllines of the EUT with burst noise for 1 minute.

7.5 Test Specification

According to EN 61000-4-4/1995

7.6 Test Result

The measurement of the Electrical Fast Transient/Burst was investigated and test result was shown on the appendix A. The acceptance criterion was met and the EUT has passed the measurement.

8 Surge

8.1 Test Equipment List

No	Instrument	Manufacture	Model	Serial No.	Last Calibrate
1.	EMC Test System	EMC Partner	Transient-1000	TR1000-341	Aug. 25, 1999

Remark: All equipment upon which need to calibrated are with calibration period of 1.5 year.

8.2 Test Setup

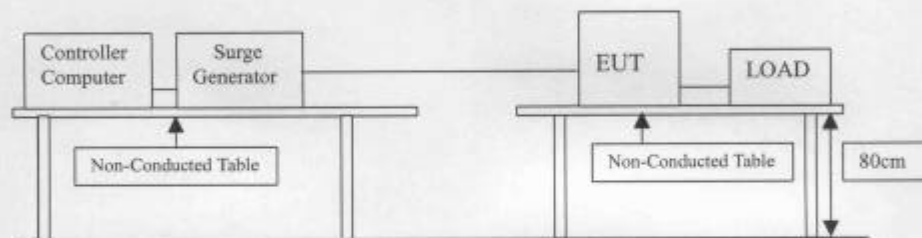

8.3 Test Level

Item	Environment	Unit	Test Specification	Performance Criteria
Dc Input and DC Output Power Ports				
	Surge	Tr/Ts (μ s)	1.2/50(8/20)	B
	Line to Ground	KV	± 0.5	
	Line to Line	KV	± 0.5	
AC Input and Ac Output Power Ports				
	Surge	Tr/Ts (μ s)	1.2/50(8/20)	B
	Line to Ground	KV	± 4	
	Line to Line	KV	± 2	

8.4 Test Procedure

The EUT and its load are placed on a table which is 0.8 meter height above a metal ground plane dimension is 1 meter x 1 meter and the thickness is 0.5 mm. It's also projected beyond the EUT at least 0.1 meter on all sides. The length of power cord between the coupling device and the EUT shall be 2meter or less.

For Input and Output AC Power or DC Input and Dc Output Power Ports:
The EUT is connected to the power mains through a coupling device that directly couples the Surge interference signal.

The Surge noise shall be applied synchronized to the voltage phase at 0°, 90°, 180°, 270° and the peak value of the AC voltage wave. (Positive and Negative) Each of line-earth and line-line is impressed with a sequence of five surge voltages with interval of 1 minute.

8.5 Test Specification

According to EN 61000-4-5/1995

8.6 Test Result

The Measurement of the Surge was investigated and the test result was shown on the appendix A. The acceptance criterion was met and the EUT has passed the test.

9 Conducted Susceptibility

9.1 Test Equipment List

No.	Instrument	Manufacture	Model	Serial No.	Last Calibrate
1.	Signal Generator	Rohde & Schwarz	SMY 02	845069/018	May 02, 1999
2.	Power Amplifier	Amplifier Research	100W1000M1A	20638	May 01, 1999
4.	Directional Coupler	Amplifier Research	DC2600	20508	Aug. 23, 1999
5.	CDN	FCC	FCC-801-M3-25A	9993	Aug. 23, 1999

Remark: All equipment upon which need to calibrated are with calibration period of 1.5 year.

9.2 Test Setup

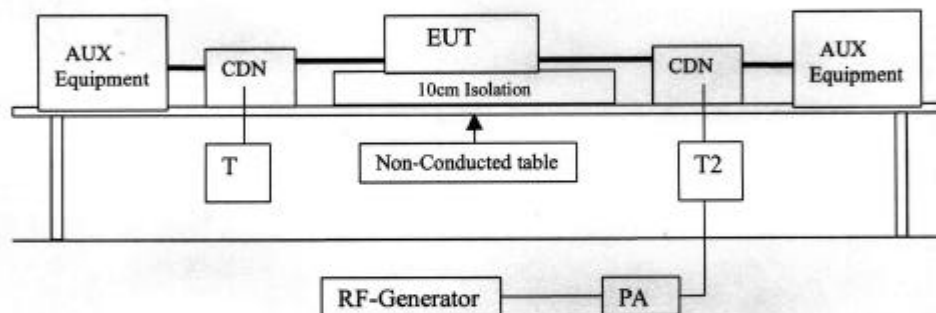

9.3 Test Level

Item	Environment	Unit	Test Specification	Performance Criteria
Ports for Signal Lines and Data Buses, not involved in process control, etc.				
	Radio-Frequency	MHz		0.15 ~ 80
	Common Mode	V (rms, Unmodulated)		10
	Amplitude Modulated	%AM (1KHz)		80
		Source Impedance		150
Ac Input and AC Output and DC Input and DC output Ports and Functional Earth Ports				
	Radio-Frequency	MHz		0.15 ~ 80
	Common Mode	V (rms, Unmodulated)		10
	Amplitude Modulated	%AM (1KHz)		80
		Source Impedance		150

9.4 Test Procedure

The EUT are placed on a table which is 0.8meter height and a ground reference plane on the table, the EUT are placed upon table and use a 10cm insulation between the EUT and ground reference plane.

For AC Input and AC Output Power or DC Input and DC Output Power Ports
The EUT is connected to the power mains through a coupling and decoupling networks for power supply lines. It also directly couples the disturbance signal into EUT. Use CDN-M2 for two wires or CDN-3 for three wires.

For Signal Lines Lines and Control Lines Test:

The disturbance signal is through a coupling and decoupling networks (CDN) or EM-clamp device couples to the signal and control lines of the EUT.

All scanning frequencies conditions are as following:

Condition of Test	Remarks:
1. Field Strength	10V, Level 3
2. Radiated Signal	AM 80% modulated with 1KHz
3. Scanning frequencies	0.15MHz ~ 80MHz
4. Dwell Time	3 seconds
5. Frequency step size Δf	1%
6. The rate of Swept of Frequency	1.5×10^{-3} decades/s

***** The above measurement was performed in HomeTek Technology Inc. *****

9.5 Test Specification

According to EN 61000-4-6/1995

9.6 Test Result

The Measurement of the Conducted Susceptibility was investigated and the test result was shown on the appendix A. The acceptance criterion was met and the EUT has passed the test.

10 Power Frequency Magnetic Field

10.1 Test Equipment List

No.	Instrument	Manufacture	Model	Serial No.	Last Calibrate
1.	EMC Test System	EMC Partner	Transient-1000	TR1000-341	Aug. 25, 1999
2.	Magnetic Coil	EMC Partner	MF-1000	MF1000-1-51	Aug. 25, 1999

Remark: All equipment upon which need to calibrated are with calibration period of 1.5 year.

10.2 Test Setup

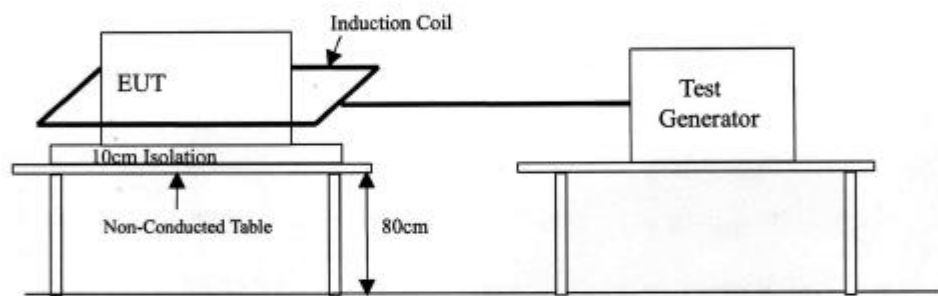

10.3 Test Level

Item	Environment	Unit	Test Specification	Performance Criteria
Enclosure Room				
Power-Frequency		50	Hz	A
Magnetic Field		30	A/M	

10.4 Test Procedure

The EUT and its load are placed on a table that is 0.8 meter above the metal ground plane dimension is at least 1 meter x 1 meter. The test magnetic field shall be placed at least than 3 meter distance from the induction coil.

The test magnetic field shall be applied by the immersion method to the EUT. The induction coil shall be rotated by 90° in order to expose the EUT to the test field with different orientation (X, Y, Z orientation).

10.5 Test Specification

According to EN 61000-4-8/1995

10.6 Test Result

The Measurement of the Power Frequency Magnetic Field was investigated and the test result was shown on the appendix A. The acceptance criterion was met and the EUT has passed the test.

11. Voltage Dips and Interruption Measurement

11.1 Test Equipment List

No.	Instrument	Manufacture	Model	Serial No.	Last Calibrate
1.	EMC Test System	EMC Partner	Transient-1000	TR1000-341	Aug. 25, 1999

Remark: All equipment upon which need to calibrated are with calibration period of 1.5 year.

11.2 Test setup

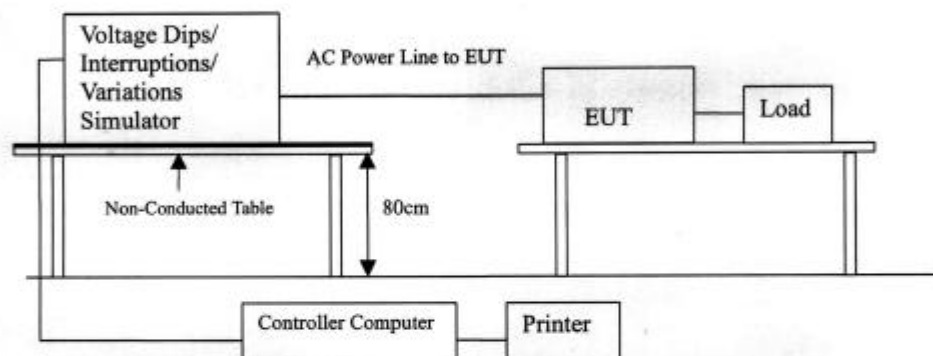

11.3 Test Level

Item	Environment	Unit	Test Specification	Performance Criteria
Ac Input and AC Output Power Ports				
	Voltage Dips	30	% Reduction	B
		10	ms	
		60	% reduction	C
		100	ms	
		>95%	Reduction	C
	Voltage Interruption	5000	ms	

11.4 Test Procedure

The EUT and its load are placed on a wooden table which is 0.8 meter above a metal ground plane which dimension is 1 meter x 1 meter, the thickness is 0.65mm. It projected beyond the EUT by at least 0.1 meter on all sides. The power cord shall be used the shortest power cord as specified by the manufacturer.

For Voltage Dips / Interruption Test:

The EUT is connected to the power mains through a coupling device that directly couples to the Voltage Dips and Interruption Generator.

The EUT shall be tested for 30% voltage dips of supplied voltage and duration time is 10ms, for 60% voltage dips of supplied voltage and duration time is 100ms with a sequence of three voltage dips with intervals of 10 seconds, and for 95% voltage interruption of supplied voltage and the duration time is 5000ms with a sequence of three voltage interruptions with intervals of 10 seconds.

Voltage phase shifting are shall occur at 0°, 45°, 90°, 135°, 180°, 225°, 270°, 315° of the voltage.

11.5 Test Specification

According to EN 61000-4-11/1995

11.6 Test Result

The Measurement of the Voltage Dips and Interruption was investigated and the test result was shown on the appendix A. The acceptance criterion was met and the EUT has passed the test.

12 Modification List for EMC Complying Test

The modification list for Model: AMB-2051 is as below:

1. The cable that from J12 of main board to CN13 of back panel (No. TB-908C) was covered by conductive shielding gasket (TennRich International Corp.)
2. The hole in the rear part of case was sealed by double side conductive copper sheet (TennRich International Corp.)
3. The outlet of USB connector and RJ-45 connector were covered by double side conductive copper sheet (TennRich International Corp.). then, soldering three finger of copper finger strip on the copper sheet on the top side of connectors, which is used to enhance grounding.
4. TC 35 = 10 μ f, 50V
5. Add a SMD capacitor, 4.7 μ f, at the pin 25, pin 27 and pin 26, pin 28 of J18 of connector board.
6. Add two capacitors (10 μ f, 25V) at the pin 27 and pin 30 of J18 of connector board.
7. The cable that connected with CN1 of LCD signal pad was wined with one ferrite core (King Core Electronics Inc., A5 FS 38 x 0.35 x 10)
8. The cable that connected with CN10 of LCD signal pad was wined with one ferrite core (King Core Electronics Inc., A5 FPC 25 x 2.8 x 12)
9. The cable that connected with CN1, CN3 and CN6 of connector pad was wined two ferrite cores (King Core Electronics Inc., A5 FPC 25 x 2.8 x 12)

***** Remark:**

Please refers to the Appendix C: The Detail Photograph of EUT

13 Appendix

Appendix A: Summary of Test Result

Appendix B: The test photograph of EUT

Appendix C: The Detail Photograph of EUT

Appendix A: Summary of Test Result

The test result in the emission and immunity were performed according to the requirement of measurement standard and procedures. Best Laboratory is assumed full responsibility for the accuracy and completeness of these measurements. The Test data of the emissions and immunity are listed as the appendix data.

All these tests are were carried out with the EUT in normal operation, which was defined as:

******* EMC Test Result: The EUT has been pass the all measurements. *******

The uncertainty is calculated in accordance with NAMAS NIS 81, the total uncertainty for this test is as follows:

⇒ Emission Test

- * Uncertainty in the Conducted Emission Test: $\lt; \pm 2.0\text{dB}$
- * Uncertainty in the Field Strength measurement: $\lt; \pm 4.0\text{dB}$

Conducted Emission Test

Date Measurement Performed: Jan 17, 2001
 EUT : Panel PC
 Testing Mode : 1024 x 768
 Temperature : 22°C
 Humidity : 74%RH

Line 1:

Frequency (KHz)	Corrected Amplitude (dB μ V/m)			Limit (dB μ V/m)		Margin dB
	Peak	QP	Avg.	QP	Avg.	
178.050	52.33	*,**	*,**	79.00	66.00	-13.67
212.050	46.62	*,**	*,**	79.00	66.00	-19.38
283.450	41.39	*,**	*,**	79.00	66.00	-24.61
388.850	38.64	*,**	*,**	79.00	66.00	-27.36
603.900	36.90	*,**	*,**	73.00	60.00	-23.10
818.100	38.25	*,**	*,**	73.00	60.00	-21.75

Line 2:

Frequency (KHz)	Corrected Amplitude (dB μ V/m)			Limit (dB μ V/m)		Margin dB
	Peak	QP	Avg.	QP	Avg.	
176.350	52.17	*,**	*,**	79.00	66.00	-13.83
213.750	48.57	*,**	*,**	79.00	66.00	-17.43
247.750	42.86	*,**	*,**	79.00	66.00	-23.14
286.850	40.67	*,**	*,**	79.00	66.00	-25.33
320.000	39.84	*,**	*,**	79.00	66.00	-26.16
389.700	39.80	*,**	*,**	79.00	66.00	-26.20

*** Remark: The above corrected amplitudes are all under the average limit. ***

Field Strength Test

Date Measurement Performed: Jan 17, 2001
 EUT : Panel PC
 Testing Mode : 1024 x 768
 Polarity : Vertical
 Temperature : 27°C
 Humidity : 73%RH

Frequency (MHz)	Reading Amplitude (dB μ V/m)	Table Degree (°)	Antenna Height (Meter)	Correction Factor (dB/m)	Corrected Amplitude (dB μ V/m)	Limit (dB μ V/m)	Margin (dB)
162.488	20.39	196	1.00	13.28	33.67	40.00	-6.33
168.976	21.87	155	1.00	12.81	34.69	40.00	-5.31
175.480	28.89	50	1.00	12.15	35.43	40.00	-4.57
181.952	26.32	70	1.00	11.48	37.80	40.00	-2.20
188.477	20.47	250	1.00	10.86	31.33	40.00	-8.67
194.974	24.90	184	1.00	10.43	35.33	40.00	-4.67
201.437	19.27	226	1.00	10.15	29.42	40.00	-10.58
207.966	29.95	173	1.00	10.14	39.56	40.00	-0.44
214.380	23.59	228	2.00	10.34	33.93	40.00	-6.07
240.470	29.20	186	1.00	11.80	40.99	47.00	-6.01
272.950	23.98	165	1.00	12.76	36.74	47.00	-10.26

Remark:

1. The " Correction Factor " contains antenna factor, cable loss.
2. The formula of " Corrected Amplitude " is as follow"
 Reading Amplitude + Correction Factor = Corrected Amplitude.

Field Strength Measurement

Date Measurement Performed: Jan 17, 2001

EUT : Panel PC
 Testing Mode : 1024 x 768
 Polarity : Horizontal
 Temperature : 27°C
 Humidity : 73%RH

Frequency (MHz)	Reading Amplitude (dB μ V/m)	Table Degree (°)	Antenna Height (Meter)	Correction Factor (dB/m)	Corrected Amplitude (dB μ V/m)	Limit (dB μ V/m)	Margin (dB)
33.510	12.33	360	2.00	11.19	23.52	40.00	-16.48
100.200	20.44	83	4.00	9.68	30.12	40.00	-9.88
129.990	17.66	153	4.00	12.06	29.72	40.00	-10.28
162.300	7.90	326	4.00	13.29	21.19	40.00	-18.81
194.700	5.38	305	4.00	10.45	15.83	40.00	-24.17
812.399	3.66	331	1.00	24.09	27.76	47.00	-19.24
974.100	-1.70	191	2.00	25.96	24.26	47.00	-22.74

Remark:

1. The " Correction Factor " contains antenna factor, cable loss.
2. The formula of " Corrected Amplitude " is as follow"
 Reading Amplitude + Correction Factor = Corrected Amplitude.

Power Harmonic / Fluctuation Test

Test Frequency : 50Hz
Test Time : 10 min.

Test Voltage : 230VAC
Tshort : 5.0 min

EUT	Data	Limit	Result	Test Enable
Pst	0.001	1.00	Pass	True
Plt	0.001	0.65	Pass	True
dc %	0.00	3.00	Pass	True
dmax %	0.00	4.00	Pass	True
d(t) sec	0.00	0.20	Pass	True

Power Source Data

Source Pst max	0.022	0.400	Pass	True
% THD	0.02	3.00	Pass	True

Electrostatic Discharge Test

Item	Amount of Discharge	Voltage	Required Criteria	Complied to Criteria	Results
Air Discharge	10	+8KV	B	B	Pass
	10	-8KV	B	B	Pass
Contact Discharge	10	+4KV	B	B	Pass
	10	-4KV	B	B	Pass
Indirect Discharge (HCP)	10	+4KV	B	B	Pass
	10	-4KV	B	B	Pass
Indirect Discharge (VCP Front)	10	+4KV	B	B	Pass
	10	-4KV	B	B	Pass
Indirect Discharge (VCP left)	10	+4KV	B	B	Pass
	10	-4KV	B	B	Pass
Indirect Discharge (VCP Rear)	10	+4KV	B	B	Pass
	10	-4KV	B	B	Pass
Indirect Discharge (VCP Right)	10	+4KV	B	B	Pass
	10	-4KV	B	B	Pass

Remark:

- Criteria A: Operation as intended during and after the measurement
- Criteria B: Operation as Intended after the test
- Criteria C: Malfunction during and after, need manual reset
- Criteria D: The sample is damaged

Radiated Susceptibility

Frequency (MHz)	Position (Angle)	Polarity (H or V)	Voltage (KV)	Required Criteria	Complied Criteria	Result
80 ~ 1000	0	H	10	A	A	Pass
80 ~ 1000	0	V	10	A	A	Pass
80 ~ 1000	90	H	10	A	A	Pass
80 ~ 1000	90	V	10	A	A	Pass
80 ~ 1000	180	H	10	A	A	Pass
80 ~ 1000	180	V	10	A	A	Pass
80 ~ 1000	270	H	10	A	A	Pass
80 ~ 1000	270	V	10	A	A	Pass

Remark:

- Criteria A: Operation as intended during and after the measurement
- Criteria B: Operation as Intended after the test
- Criteria C: Malfunction during and after, need manual reset
- Criteria D: The sample is damaged

Electrical Fast Transient / Burst

Inject Line	Polarity	Voltage (KV)	Inject Time (Second)	Inject Method	Required Criteria	Complied Criteria	Result
L	±	2KV	60	Direct	B	B	Pass
N	±	2KV	60	Direct	B	B	Pass
PE	±	2KV	60	Direct	B	B	Pass
L+N	±	2KV	60	Direct	B	B	Pass
L+PE	±	2KV	60	Direct	B	B	Pass
N+PE	±	2KV	60	Direct	B	B	Pass
L+N+PE	±	2KV	60	Direct	B	B	Pass
Clamp	±	1KV	60	Couple	B	B	Pass

Remark:

- Criteria A: Operation as intended during and after the measurement
- Criteria B: Operation as Intended after the test
- Criteria C: Malfunction during and after, need manual reset
- Criteria D: The sample is damaged

Surge Test

Inject Line	Polarity	Angle	Voltage (KV)	Inject Time (Second)		Required Criteria	Complied Criteria	Result
L+N	±	0	2KV	60	Direct	B	B	Pass
L+N	±	90	2KV	60	Direct	B	B	Pass
L+N	±	180	2KV	60	Direct	B	B	Pass
L+N	±	270	2KV	60	Direct	B	B	Pass
L+PE	±	0	4KV	60	Direct	B	B	Pass
L+PE	±	90	4KV	60	Direct	B	B	Pass
L+PE	±	180	4KV	60	Direct	B	B	Pass
L+PE	±	270	4KV	60	Direct	B	B	Pass
N+PE	±	0	4KV	60	Direct	B	B	Pass
N+PE	±	90	4KV	60	Direct	B	B	Pass
N+PE	±	180	4KV	60	Direct	B	B	Pass
N+PE	±	270	4KV	60	Direct	B	B	Pass

Remark:

- Criteria A: Operation as intended during and after the measurement
- Criteria B: Operation as Intended after the test
- Criteria C: Malfunction during and after, need manual reset
- Criteria D: The sample is damaged

Conducted Susceptibility

Inject Line	Field Strength V	Inject Method	Required Criteria	Complied Criteria	Result
AC Line	10V	CDN	A	A	Pass

Remark:

- Criteria A: Operation as intended during and after the measurement
- Criteria B: Operation as Intended after the test
- Criteria C: Malfunction during and after, need manual reset
- Criteria D: The sample is damaged

Power Frequency Magnetic Field Test

Polarization	Frequency (Hz)	Magnetic Strength (A/M)	Required Criteria	Complied Criteria	Result
X Orientation	50	30	A	A	Pass
Y Orientation	50	30	A	A	Pass
Z Orientation	50	30	A	A	Pass

Remark:

- Criteria A: Operation as intended during and after the measurement
- Criteria B: Operation as Intended after the test
- Criteria C: Malfunction during and after, need manual reset
- Criteria D: The sample is damaged

Voltage Dips and Interruption Test

Voltage Dips and Interruption Reduction (%)	Angle (Degree)	Test Duration (ms)	Required Criteria	Complied Criteria	Result
30	45	10	B	B	Pass
30	90	10	B	B	Pass
30	135	10	B	B	Pass
30	180	10	B	B	Pass
30	225	10	B	B	Pass
30	270	10	B	B	Pass
30	315	10	B	B	Pass
60	45	100	C	C	Pass
60	90	100	C	C	Pass
60	135	100	C	C	Pass
60	180	100	C	C	Pass
60	225	100	C	C	Pass
60	270	100	C	C	Pass
60	315	100	C	C	Pass
>95	45	5000	C	C	Pass
>95	90	5000	C	C	Pass
>95	135	5000	C	C	Pass
>95	180	5000	C	C	Pass
>95	225	5000	C	C	Pass
>95	270	5000	C	C	Pass
>95	315	5000	C	C	Pass

Remark:

- Criteria A: Operation as intended during and after the measurement
- Criteria B: Operation as Intended after the test (Test Mode: 30%)
- Criteria C: Malfunction during and after, need manual reset(Test Mode: 60%, >95%)
- Criteria D: The sample is damaged



Appendix B: The Test Photograph of EUT



The Photograph of Conducted Emission Test

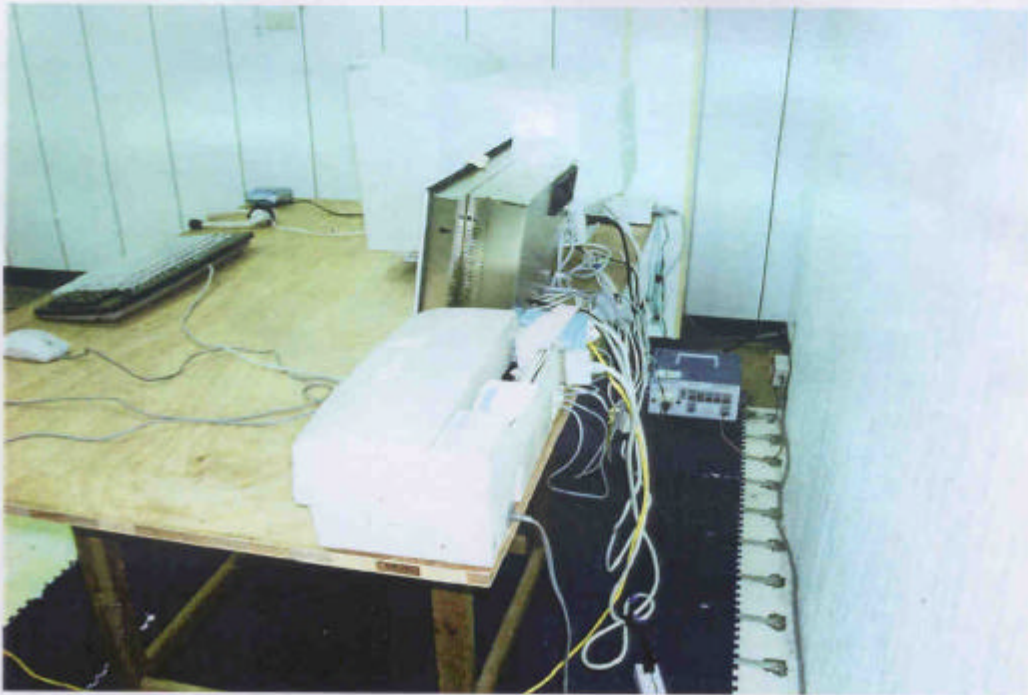

The Photograph of Radiated Emission Test

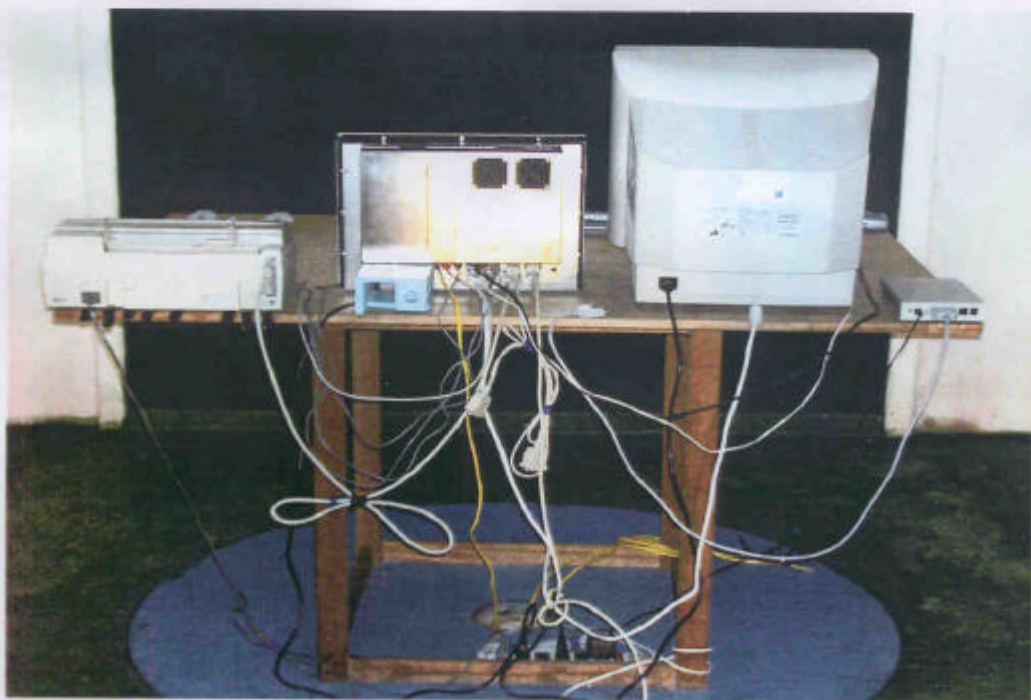
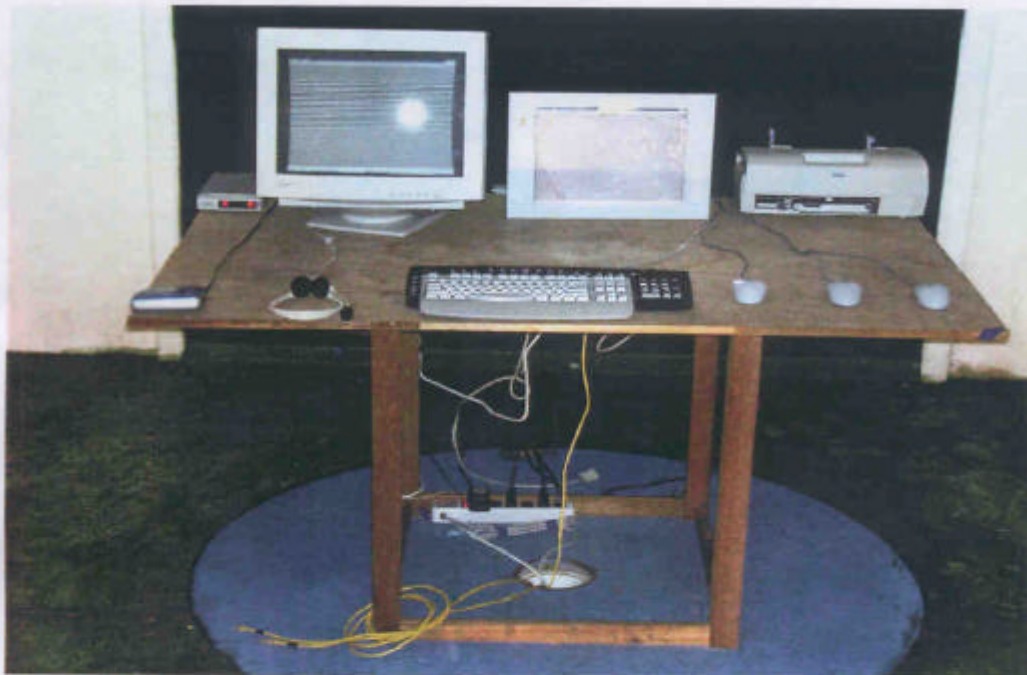

The Photograph of Radiation Susceptibility Test

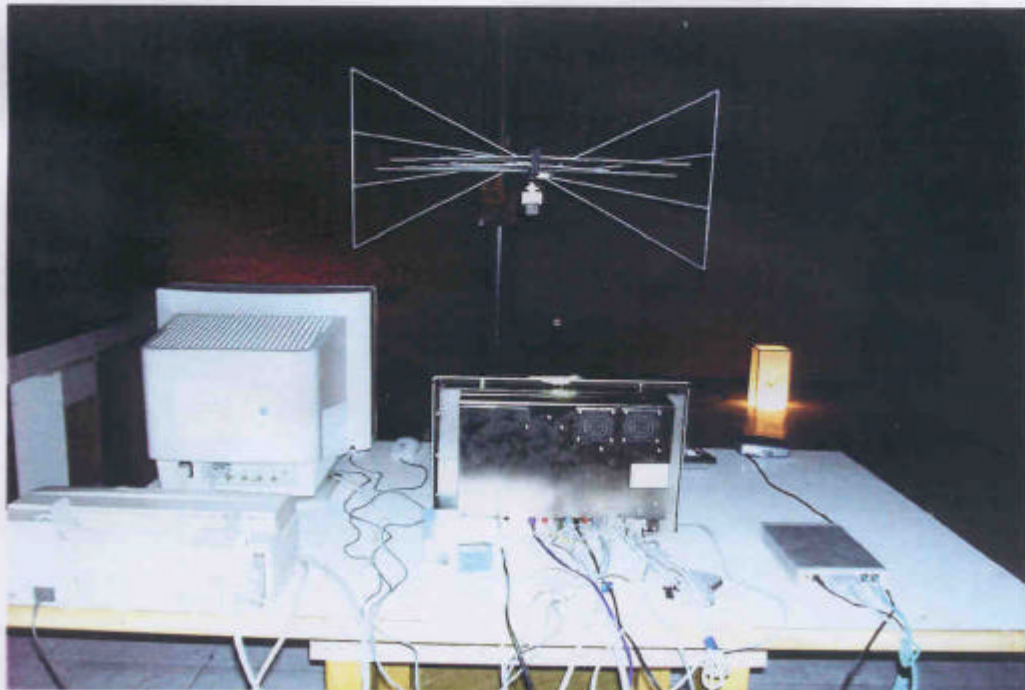

The Photograph of Electrical Fast Transient/Burst Test



The Photograph of Electrostatic Discharge Test



The Photograph of Electrical Fast Transient/Burst Test



The Photograph of Electrostatic Discharge Test



The Photograph of Surge Test



The Photograph of Conducted Susceptibility Test

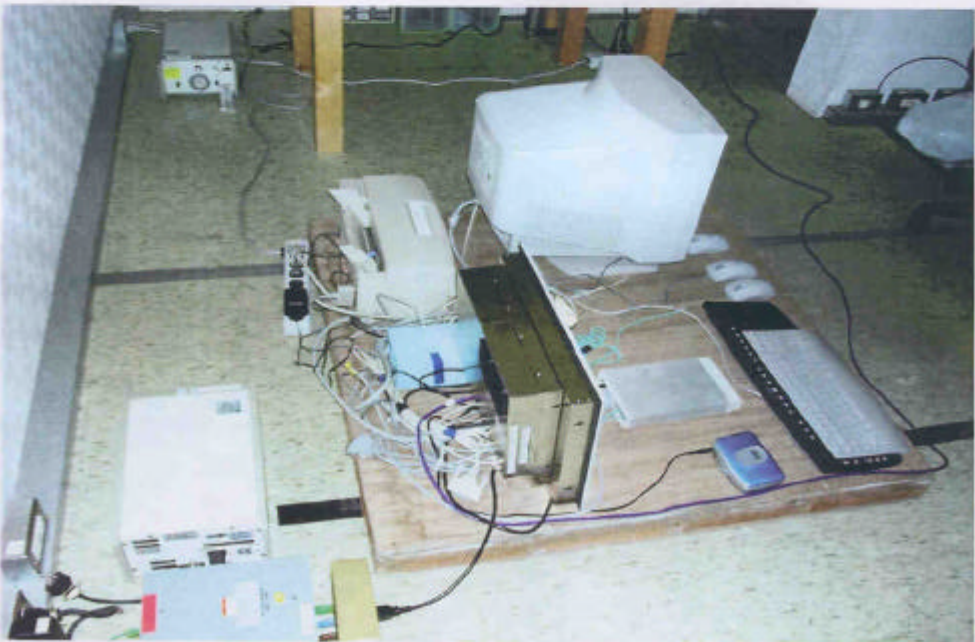

The Photograph of Power Frequency Magnetic Field Test



The Photograph of Voltage Dips and Interruption Test



Appendix C: The Detail Photograph of EUT

