

# FCC DoC TEST REPORT

for

**PC/104 CPU Module**

**MODEL: PFM-540I**

Test Report Number:

**61026203-F**

Issued to:

**AAEON Technology Inc.**

**5F, No. 135, Lane 235, Pao Chiao Rd., Hsin-Tien City,  
Taipei, Taiwan, R.O.C.**

Issued by:

**Compliance Certification Services Inc.**

**Hsintien Lab.**

**No. 163-1, Chungsen Road, Hsintien City  
Taipei Hsien, Taiwan**

**TEL: (02) 2217-0894**

**FAX: (02) 2217-1029**

**Issued Date: November 20, 2006**



*Note: This report shall not be reproduced except in full, without the written approval of Compliance Certification Services Inc. This document may be altered or revised by Compliance Certification Services Inc. personnel only, and shall be noted in the revision section of the document. The client should not use it to claim product endorsement by TAF, A2LA, NVLAP, NIST or any government agencies. The test results in the report only apply to the tested sample.*



**Revision History**

Rev.	Issue Date	Revisions	Effect Page	Revised By
00		Initial Issue	ALL	



**TABLE OF CONTENTS**

**1 TEST RESULT CERTIFICATION ..... 4**

**2 EUT DESCRIPTION ..... 5**

**3 TEST METHODOLOGY ..... 6**

**3.1. DECISION OF FINAL TEST MODE ..... 6**

**3.2. EUT SYSTEM OPERATION ..... 6**

**4 SETUP OF EQUIPMENT UNDER TEST ..... 7**

**4.1. DESCRIPTION OF SUPPORT UNITS ..... 7**

**4.2. CONFIGURATION OF SYSTEM UNDER TEST ..... 8**

**5 FACILITIES AND ACCREDITATIONS ..... 9**

**5.1. FACILITIES ..... 9**

**5.2. ACCREDITATIONS ..... 9**

**5.3. MEASUREMENT UNCERTAINTY ..... 9**

**6 CONDUCTED EMISSION MEASUREMENT ..... 10**

**6.1. LIMITS OF CONDUCTED EMISSION MEASUREMENT ..... 10**

**6.2. TEST INSTRUMENTS ..... 10**

**6.3. TEST PROCEDURES ..... 11**

**6.4. TEST SETUP ..... 12**

**6.5. DATA SAMPLE: ..... 12**

**6.6. TEST RESULTS ..... 13**

**7 RADIATED EMISSION MEASUREMENT ..... 14**

**7.1. LIMITS OF RADIATED EMISSION MEASUREMENT ..... 14**

**7.2. TEST INSTRUMENTS ..... 14**

**7.3. TEST PROCEDURES ..... 15**

**7.4. TEST SETUP ..... 17**

**7.5. DATA SAMPLE: ..... 17**

**7.6. TEST RESULTS ..... 18**

**8 PHOTOGRAPHS OF THE TEST CONFIGURATION ..... 20**



# 1 TEST RESULT CERTIFICATION

**Product:** PC/104 CPU Module

**Model:** PFM-540I

**Brand:** AAEON

**Applicant:** AAEON Technology Inc.  
5F, No.135, Lane 235, Pao Chiao Rd., Hsin-Tien City,  
Taipei, Taiwan, R.O.C.

**Manufacturer:** AAEON Technology Inc.  
5F, No.135, Lane 235, Pao Chiao Rd., Hsin-Tien City,  
Taipei, Taiwan, R.O.C.

**Tested:** November 3, 2006 & November 13, 2006

EMISSION			
Standard	Item	Result	Remarks
FCC 47 CFR Part 15 Subpart B, ICES-003 Issue 4 ANSI C63.4-2003	Conducted (Main Port)	PASS	Meet Class A limit
	Radiated	PASS	Meet Class A limit

*Note:* 1. The test result judgment is decided by the limit of measurement standard.  
2. The information of measurement uncertainty is available upon the customer's request.

Deviation from Applicable Standard
None

The above equipment has been tested by Compliance Certification Services Inc., and found compliance with the requirements set forth in the technical standards mentioned above. The results of testing in this report apply only to the product/system, which was tested. Other similar equipment will not necessarily produce the same results due to production tolerance and measurement uncertainties.

Approved by:

\_\_\_\_\_  
David Wang  
Manager of Hsintien Laboratory

Reviewed by:

\_\_\_\_\_  
Vince Chiang  
Assistant Manager of Hsintien Laboratory



## 2 EUT DESCRIPTION

<b>Product</b>	PC/104 CPU Module
<b>Brand Name</b>	AAEON
<b>Model</b>	PFM-540I
<b>Test Item</b>	Engineering Sample
<b>Applicant</b>	AAEON Technology Inc.
<b>Housing material</b>	Metal case
<b>EUT Type</b>	<input checked="" type="checkbox"/> Engineering Sample. <input type="checkbox"/> Product Sample. <input type="checkbox"/> Mass Product Sample.
<b>Serial Number</b>	N/A
<b>Received Date</b>	October 26, 2006
<b>EUT Power Rating</b>	100-240VAC
<b>OSC/Clock Frequency</b>	Y1: 32.768kHz; Y2: 14.318MHz; Y3: 25MHz

### I/O PORT

I/O PORT TYPES	Q'TY	TESTED WITH
1). PIO Port	1	1
2). SIO Port	2	2
3). DB 5pin Keyboard Port	1	1
4). PS/2 Mouse Port	1	1
5). VIDEO OUT Port (VGA)	1	1
6). LAN Port	1	1
7). USB Port	4	4

*Note: Client consigns only one model sample (Model Number is PFM-540I) to test.*



### 3 TEST METHODOLOGY

#### 3.1. DECISION OF FINAL TEST MODE

The EUT was tested together with the above additional components, and a configuration, which produced the worst emission levels, was selected and recorded in this report.

The test configuration/ mode(s) is as the following:

**Conduction:**

1	Normal Mode
---	-------------

**Radiation:**

1	Normal Mode
	Normal Mode / 1-5GHz

**Conduction:** Mode 1

**Radiation:** Mode 1

#### 3.2. EUT SYSTEM OPERATION

1. Windows XP boots system.
2. Run Emctest.exe to activate all peripherals and display “H” pattern on monitor screen.
3. Run Winemc.exe and select (E:/ & F:/ & G:/ & H:/) to test USB 2.0 ports.
4. Press the start menu, select executive and type ping 192.168.0.2-t (EUT), ping 192.168.0.1 -t (Server Notebook).

*Note: Test program is self-repeating throughout the test.*



## 4 SETUP OF EQUIPMENT UNDER TEST

### 4.1. DESCRIPTION OF SUPPORT UNITS

The EUT has been tested as an independent unit together with other necessary accessories or support units. The following support units or accessories were used to form a representative test configuration during the tests.

#### Support Equipment

##### Host PC Devices:

No	Equipment	Model #	Trade Name
1	CPU (500MHz)	Geode-GX	AMD
2	Hard Disk (80.3GB)	HDS728080PLAT20	Hitachi
3	MEMORY (DDR333 256MB)	V58C2256804SCT6	Transcend
4	Power Supply	ENH-0620	Enhance

##### Peripherals Devices:

No.	Equipment	Model No.	Serial No.	FCC ID / BSMI ID	Trade Name	Data Cable	Power Cord
1	USB 2.0 HDD	F12-U	N/A	BSMI ID: 4912A002	Terasys	Shielded, 1.8m	N/A
2	USB 2.0 HDD	F12-U	N/A	BSMI ID: 4912A002	Terasys	Shielded, 1.8m	N/A
3	USB 2.0 HDD	F12-U	N/A	BSMI ID: 4912A002	Terasys	Shielded, 1.8m	N/A
4	USB 2.0 HDD	F12-U	N/A	BSMI ID: 4912A002	Terasys	Shielded, 1.8m	N/A
5	PS/2 Mouse	M071KC	443029525	DoC BSMI: R41108	DELL	Shielded, 1.8m	N/A
6	DB 5pin Keyboard	5201	N/A	N/A	LEMEL	Shielded, 1.4m	N/A
7	Modem	5JEG4033MKO	N/A	5RJTAI-35500-M5-E	TOP-SOLUTION	Shielded, 0.9m	Unshielded, 1.8m
8	Modem	5JEG4033MKO	N/A	5RJTAI-35500-M5-E	TOP-SOLUTION	Shielded, 0.9m	Unshielded, 1.8m
9	Printer	C20SX	N/A	BSMI ID: 3902E004	EPSON	Shielded, 1.8m	Unshielded, 1.8m
10	Monitor	710V	GS17H9NXA05855D	DoC BSMI: R33475	SAMSUNG	Shielded, 1.8m with two cores	Unshielded, 1.8m
11	Server Notebook	PP05L	2464936188	DoC BSMI: R33002	DELL	Unshielded, 20m	Unshielded, 1.8m with a core

##### Note:

- 1) All the equipment/cables were placed in the worst-case configuration to maximize the emission during the test.
- 2) Grounding was established in accordance with the manufacturer's requirements and conditions for the intended use.

#### 4.2. CONFIGURATION OF SYSTEM UNDER TEST

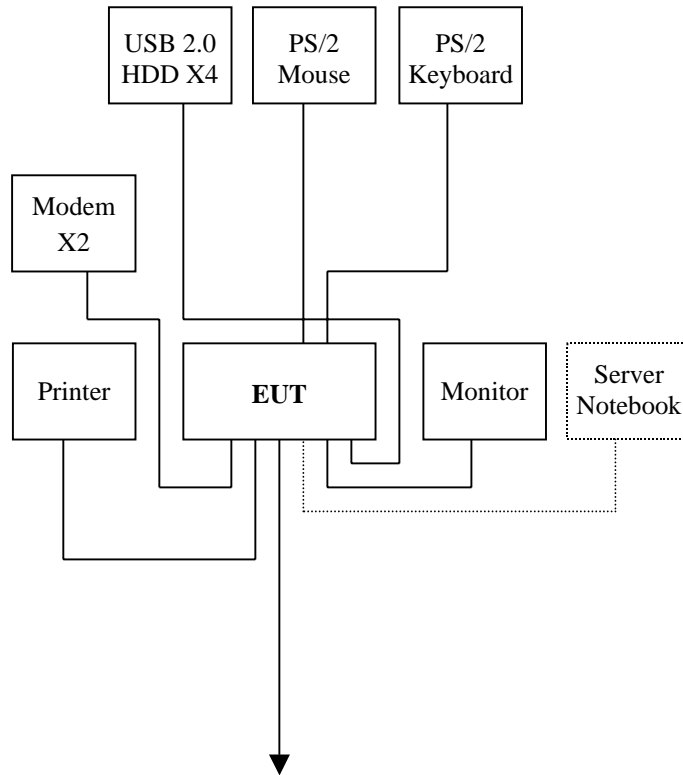



## 5 FACILITIES AND ACCREDITATIONS

### 5.1. FACILITIES

All measurement facilities used to collect the measurement data are located at CCS Taiwan Hsintien Lab at No. 163-1, Chunghsen Road, Hsintien City, Taipei Hsien, Taiwan.

The sites are constructed in conformance with the requirements of ANSI C63.4 and CISPR Publication 22. All receiving equipment conforms to CISPR Publication 16-1, "Radio Interference Measuring Apparatus and Measurement Methods."

### 5.2. ACCREDITATIONS

Our laboratories are accredited and approved by the following approval agencies according to ISO/IEC 17025.

<b>USA</b>	FCC, A2LA
<b>Germany</b>	TUV Rheinland
<b>Japan</b>	VCCI
<b>Norway</b>	NEMKO
<b>Canada</b>	INDUSTRY CANADA
<b>Taiwan</b>	TAF, BSMI

Copies of granted accreditation certificates are available for downloading from our web site, <http://www.ccsemc.com.tw>

### 5.3. MEASUREMENT UNCERTAINTY

Where relevant, the following measurement uncertainty levels have been estimated for tests performed on the EUT as specified in CISPR 16-4-2:

Measurement	Frequency	Uncertainty	
Conducted emissions	9kHz~30MHz	$\pm 3.4508$	
Radiated emissions	Horizontal	30MHz ~ 200MHz	$\pm 4.3875$
		200MHz ~1000MHz	$\pm 4.5212$
	Vertical	30MHz ~ 200MHz	$\pm 4.5089$
		200MHz ~1000MHz	$\pm 4.5138$

This uncertainty represents an expanded uncertainty expressed at approximately the 95% confidence level using a coverage factor of k=2.



## 6 CONDUCTED EMISSION MEASUREMENT

### 6.1. LIMITS OF CONDUCTED EMISSION MEASUREMENT

FREQUENCY (MHz)	Class A (dBuV)		Class B (dBuV)	
	Quasi-peak	Average	Quasi-peak	Average
0.15 - 0.5	79	66	66 - 56	56 - 46
0.50 - 5.0	73	60	56	46
5.0 - 30.0	73	60	60	50

**NOTE:**

- (1) The lower limit shall apply at the transition frequencies.
- (2) The limit decreases in line with the logarithm of the frequency in the range of 0.15 to 0.50 MHz.
- (3) All emanations from a class A/B digital device or system, including any network of conductors and apparatus connected thereto, shall not exceed the level of field strengths specified above.

### 6.2. TEST INSTRUMENTS

Conducted Emission Test Site # A				
EQUIPMENT	MFR	MODEL	SERIAL NUMBER	CAL. DUE
TEST RECEIVER	R&S	ESHS20	840455/006	02/06/2007
LISN (EUT)	SCHWARZBECK	NSLK 8127	8127382	01/02/2007
LISN	SOLAR	8012-50-R-24-BNC	8305114	01/02/2007
BNC CABLE	JYE BAO	RG-223/U	BNC A2	10/10/2007
THERMO-HYGRO METER	TOP	HA-202	9303-1	02/22/2007
Test S/W	EMI 32.exe			

- NOTE:**
- 1. The calibration interval of the above test instruments is 12 months and the calibrations are traceable to NML/ROC and NIST/USA.
  - 2. N.C.R = No Calibration Request.



**6.3. TEST PROCEDURES** (please refer to measurement standard or CCS SOP PA-031)

**Procedure of Preliminary Test**

- The EUT and Support equipment, if needed, was set up as per the test configuration to simulate typical usage per the user's manual. When the EUT is a tabletop system, a wooden table with a height of 0.8 meters is used and is placed on the ground plane as per ANSI C63.4 (see Test Facility for the dimensions of the ground plane used). When the EUT is a floor standing equipment, it is placed on the ground plane, which has a 3-12 mm non-conductive covering to insulate the EUT from the ground plane.
- All I/O cables were positioned to simulate typical actual usage as per ANSI C63.4.
- The test equipment EUT installed received AC main power, through a Line Impedance Stabilization Network (LISN), which supplied power source and was grounded to the ground plane.
- All support equipment power received from a second LISN.
- The EUT test program was started. Emissions were measured on each current carrying line of the EUT using an EMI Test Receiver connected to the LISN powering the EUT.
- The Receiver scanned from 150kHz to 30MHz for emissions in each of the test modes.
- During the above scans, the emissions were maximized by cable manipulation.
- The test mode(s) described in Item 3.1 were scanned during the preliminary test.
- After the preliminary scan, we found the test mode described in Item 3.1 producing the highest emission level.
- The EUT configuration and cable configuration of the above highest emission levels were recorded for reference of the final test.

**Procedure of Final Test**

- EUT and support equipment were set up on the test bench as per the configuration with highest emission level in the preliminary test.
- A scan was taken on both power lines, Line 1 and Line 2, recording at least the six highest emissions. Emission frequency and amplitude were recorded into a computer in which correction factors were used to calculate the emission level and compare reading to the applicable limit.
- The test data of the worst-case condition(s) was recorded.

**6.4. TEST SETUP**

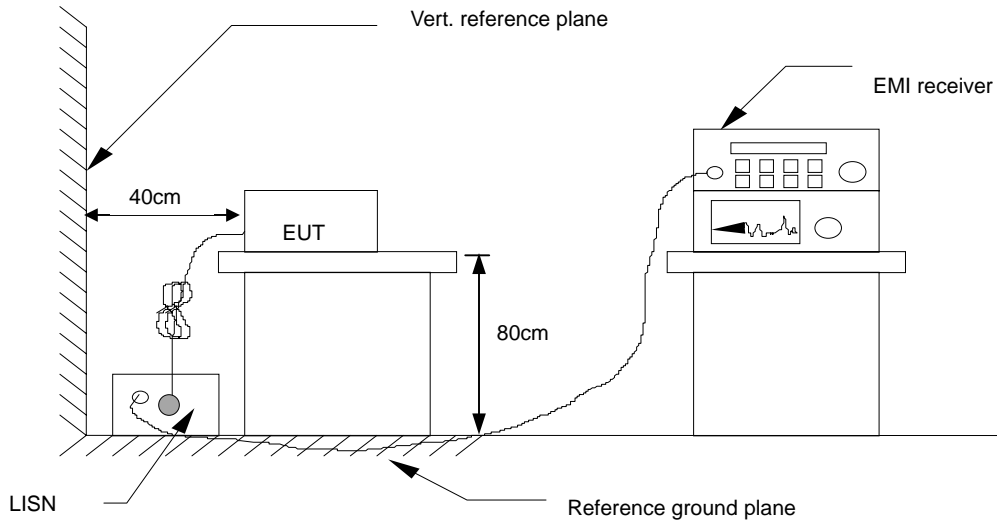

- For the actual test configuration, please refer to the related item – Photographs of the Test Configuration.

**6.5. DATA SAMPLE:**

Freq. MHz	Read Level dBuV	Factor dB	Level dBuV	Limit dBuV	Over Limit dB	Reading Type (P/Q/A)	Line (L1/L2)
x.xx	42.95	0.55	43.50	73	-29.50	Q	L1

- Freq. = Emission frequency in MHz
- Read Level = Uncorrected Analyzer/Receiver reading
- Factor = Insertion loss of LISN + Cable Loss
- Level = Read Level + Factor
- Limit = Limit stated in standard
- Over Limit = Reading in reference to limit
- P = Peak Reading
- Q = Quasi-peak Reading
- A = Average Reading
- L1 = Hot side
- L2 = Neutral side

**Calculation Formula**

Over Limit (dB) = Level (dBuV) – Limit (dBuV)



6.6. TEST RESULTS

<b>Model No.</b>	PFM-540I	<b>6dB BANDWIDTH</b>	10 kHz
<b>Environmental Conditions</b>	20°C, 54% RH, 1005mbar	<b>Test Mode</b>	Mode 1
<b>Tested by:</b>	John Yen		

(The chart below shows the highest readings taken from the final data.)

Conducted Emission Readings							
Frequency Range Investigated				150 kHz to 30 MHz			
Freq (MHz)	Read Level (dBuV)	Factor (dB)	Level (dBuV)	Limit Line (dBuV)	Over Limit (dB)	Reading Type (P/Q/A)	Line (L1/L2)
0.152	66.12	0.14	66.26	79.00	-12.74	P	L1
0.152	63.87	0.10	63.97	66.00	-2.03	A	L1
0.197	59.15	0.15	59.30	79.00	-19.70	P	L1
0.153	70.20	0.14	70.34	79.00	-8.66	P	L2
0.153	64.10	0.14	64.24	66.00	-1.76	A	L2
0.192	60.78	0.15	60.93	79.00	-18.07	P	L2
0.238	56.24	0.15	56.39	79.00	-22.61	P	L2
18.328	47.02	0.91	47.93	73.00	-25.07	P	L2

NOTE: 1.L1 = Line One (Live Line) / L2 = Line Two (Neutral Line)

2. Those frequencies only show peak emission level because that was below the Average limit, so no need to check average anymore.



## 7 RADIATED EMISSION MEASUREMENT

### 7.1. LIMITS OF RADIATED EMISSION MEASUREMENT

FREQUENCY (MHz)	dBuV/m (At 10m)	
	Class A	Class B
30 ~ 230	40	30
230 ~ 1000	47	37

**NOTE:** (1) The lower limit shall apply at the transition frequencies.  
 (2) Emission level (dBuV/m) = 20 log Emission level (uV/m).

### 7.2. TEST INSTRUMENTS

Open Area Test Site # J				
EQUIPMENT	MFR	MODEL	SERIAL NUMBER	CAL. DUE
SITE NSA	CCS	J Site	N/A	10/14/2007
MEASURE RECEIVER	SCHAFFNER	SCR3501	330	06/11/2007
SPECTRUM ANALYZER	ADVANTEST	R3132	120900003	No Calibration Required
ANTENNA	SCHAFFNER	CBL 6112B	2800	09/23/2007
PRE-AMPLIFIER	SCHAFFNER	CPA9231A	3629	10/10/2007
CABLE	BELDEN	9913	N-TYPE #J3	08/24/2007
ATTENUATOR	MCL	UNAT-6	AT06-8	12/02/2006
THERMO-HYGRO METER	TFA	N/A	NO.3	10/26/2007
Test S/W	Lab VIEW 5.1			
Above 1GHz Used				
EMC ANALYZER (100Hz-22GHz)	HP	8566B	2937A06102	07/04/2007
ANTENNA (1-18GHz)	EMCO	3115	00022256	01/12/2007
AMPLIFIER (1-18GHz)	HP	8449B	3008A01266	02/06/2007
CABLE (1-18GHz)	JYEBAO	LL142	SMA#RS1	02/06/2007
CABLE (1-18GHz)	HUBER +SUHNER	SUCOFLEX 104	SMA#RS3	02/06/2007
CABLE (1-18GHz)	JYEBAO	LL142	SMA#C1	02/06/2007



### **7.3. TEST PROCEDURES** (please refer to measurement standard or CCS SOP PA-031)

#### **Procedure of Preliminary Test**

- The equipment was set up as per the test configuration to simulate typical usage per the user's manual. When the EUT is a tabletop system, a wooden turntable with a height of 0.8 meters is used which is placed on the ground plane. When the EUT is a floor standing equipment, it is placed on the ground plane which has a 3-12 mm non-conductive covering to insulate the EUT from the ground plane.
- Support equipment, if needed, was placed as per ANSI C63.4.
- All I/O cables were positioned to simulate typical usage as per ANSI C63.4.
- The EUT received AC power source from the outlet socket under the turntable. All support equipment power received from another socket under the turntable.
- The antenna was placed at 10 meter away from the EUT as stated in ANSI C63.4. The antenna connected to the Spectrum Analyzer via a cable and at times a pre-amplifier would be used.
- The Analyzer / Receiver quickly scanned from 30MHz to 5000MHz. The EUT test program was started. Emissions were scanned and measured rotating the EUT to 360 degrees and positioning the antenna 1 to 4 meters above the ground plane, in both the vertical and the horizontal polarization, to maximize the emission reading level.
- The test mode(s) described in Item 3.1 were scanned during the preliminary test:
- After the preliminary scan, we found the test mode described in Item 3.1 producing the highest emission level.
- The EUT and cable configuration, antenna position, polarization and turntable position of the above highest emission level were recorded for the final test.



**Procedure of Final Test**

- EUT and support equipment were set up on the turntable as per the configuration with highest emission level in the preliminary test.
- The Analyzer / Receiver scanned from 30MHz to 5000MHz. Emissions were scanned and measured rotating the EUT to 360 degrees, varying cable placement and positioning the antenna 1 to 4 meters above the ground plane, in both the vertical and the horizontal polarization, to maximize the emission reading level.
- Recorded at least the six highest emissions. Emission frequency, amplitude, antenna position, polarization and turntable position were recorded into a computer in which correction factors were used to calculate the emission level and compare reading to the applicable limit and only Q.P. reading is presented.
- The test data of the worst-case condition(s) was recorded.



**7.4. TEST SETUP**

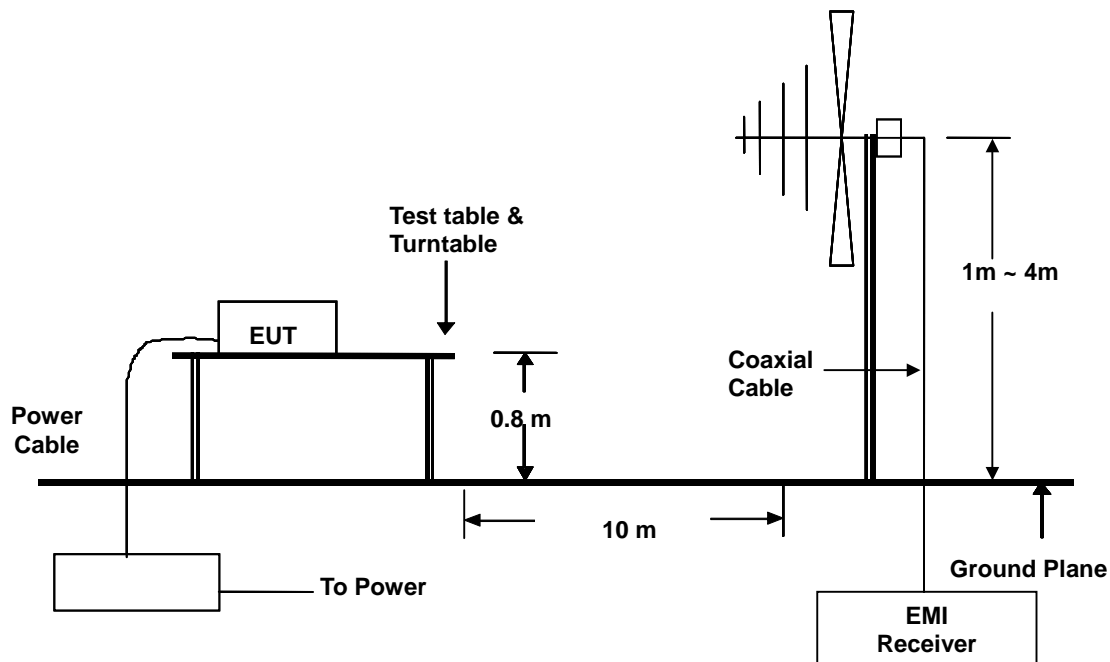

- For the actual test configuration, please refer to the related item – Photographs of the Test Configuration.

**7.5. DATA SAMPLE:**

Freq. MHz	Amptd dBuV/m	Margin dB	Limit dBuV/m	Reading dBuV	Factor dB/m	Reading Type (P/Q/A)	Pol. (H/V)
x.xx	26.2	-13.8	40	14	12.2	Q	H

- Freq. = Emission frequency in MHz
- Read Level = Uncorrected Analyzer/Receiver reading
- Factor = Antenna Factor + Cable Loss + Attenuator (3/6/10dB) – Amplifier Gain
- Level = Read Level + Factor
- Limit = Limit stated in standard
- Over Limit = Reading in reference to limit
- P = Peak Reading
- Q = Quasi-peak Reading
- A = Average Reading
- H = Antenna Polarization: Horizontal
- V = Antenna Polarization: Vertical

**Calculation Formula**

Over Limit (dB) = Level (dBuV/m) – Limit (dBuV/m)



7.6. TEST RESULTS

<b>Model No.</b>	PFM-540I	<b>6dB BANDWIDTH</b>	120 kHz
<b>Environmental Conditions</b>	25°C, 80% RH, 1010mbar	<b>Test Mode</b>	Mode 1
<b>Antenna Pole</b>	Vertical	<b>Antenna Distance</b>	10m
<b>Tested by:</b>	James Hsieh		

(The chart below shows the highest readings taken from the final data.)

Six Highest Radiated Emission Readings							
Frequency Range Investigated				30 MHz to 1000 MHz at 10m			
Freq. MHz	Amptd dBuV/m	Margin dB	Limit dBuV/m	Reading dBuV	Factor dB/m	Reading Type (P/Q/A)	Pol. (H/V)
133.2900	32.23	-7.77	40.00	42.00	-9.77	Q	V
159.8000	29.41	-10.59	40.00	40.00	-10.59	Q	V
166.3600	32.14	-7.86	40.00	43.00	-10.86	Q	V
180.7700	32.57	-7.43	40.00	44.00	-11.43	Q	V
240.1100	37.49	-9.51	47.00	46.00	-8.51	Q	V
480.2700	37.80	-9.20	47.00	39.00	-1.20	Q	V

- REMARKS:**
1. P= Peak Reading; Q= Quasi-peak Reading A= Average Reading
  2. The other emission levels were very low against the limit.
  3. 30MHz to 1000MHz test is Applicable CISPR 22 / EN 55022 standard.



<b>Model No.</b>	PFM-540I	<b>6dB BANDWIDTH</b>	120 kHz
<b>Environmental Conditions</b>	25°C, 80% RH, 1010mbar	<b>Test Mode</b>	Mode 1
<b>Antenna Pole</b>	Horizontal	<b>Antenna Distance</b>	10m
<b>Tested by:</b>	James Hsieh		

(The chart below shows the highest readings taken from the final data.)

<b>Six Highest Radiated Emission Readings</b>							
<b>Frequency Range Investigated</b>				<b>30 MHz to 1000 MHz at 10m</b>			
Freq. MHz	Amptd dBuV/m	Margin dB	Limit dBuV/m	Reading dBuV	Factor dB/m	Reading Type (P/Q/A)	Pol. (H/V)
<b>133.2900</b>	<b>33.23</b>	<b>-6.77</b>	<b>40.00</b>	<b>43.00</b>	<b>-9.77</b>	<b>Q</b>	<b>H</b>
<b>166.3300</b>	<b>33.14</b>	<b>-6.86</b>	<b>40.00</b>	<b>44.00</b>	<b>-10.86</b>	<b>Q</b>	<b>H</b>
<b>180.4100</b>	<b>31.57</b>	<b>-8.43</b>	<b>40.00</b>	<b>43.00</b>	<b>-11.43</b>	<b>Q</b>	<b>H</b>
<b>240.0100</b>	<b>38.48</b>	<b>-8.52</b>	<b>47.00</b>	<b>47.00</b>	<b>-8.52</b>	<b>Q</b>	<b>H</b>
<b>249.1800</b>	<b>38.21</b>	<b>-8.79</b>	<b>47.00</b>	<b>46.00</b>	<b>-7.79</b>	<b>Q</b>	<b>H</b>
<b>480.0200</b>	<b>39.80</b>	<b>-7.20</b>	<b>47.00</b>	<b>41.00</b>	<b>-1.20</b>	<b>Q</b>	<b>H</b>

- REMARKS:**
1. P= Peak Reading; Q= Quasi-peak Reading A= Average Reading
  2. The other emission levels were very low against the limit.
  3. 30MHz to 1000MHz test is Applicable CISPR 22 / EN 55022 standard.

**8 PHOTOGRAPHS OF THE TEST CONFIGURATION  
CONDUCTED EMISSION TEST**



**RADIATED EMISSION TEST**

