



FCC DoC TEST REPORT

for

PC/104 CPU Module

MODEL: PFM-540I-B10-xxxxxx

Test Report Number:
80320203-F

Issued to:

AAEON Technology Inc.
5F, No. 135, Lane 235, Pao Chiao Rd., Hsin-Tien City,
Taipei, Taiwan, R.O.C.

Issued by:

Compliance Certification Services Inc.
Sindian BU.
No.163-1, Jhongsheng Rd., Sindian City,
Taipei County 23151, Taiwan
TEL: 886-2-22170894
FAX: 886-2-22171029
Issued Date: March 27, 2008



Note: This report shall not be reproduced except in full, without the written approval of Compliance Certification Services Inc. This document may be altered or revised by Compliance Certification Services Inc. personnel only, and shall be noted in the revision section of the document. The client should not use it to claim product endorsement by TAF, A2LA, NVLAP, NIST or any government agencies. The test results in the report only apply to the tested sample.



Revision History

Rev.	Issue Date	Revisions	Effect Page	Revised By
00		Initial Issue	ALL	



TABLE OF CONTENTS

1 TEST RESULT CERTIFICATION.....4

2 EUT DESCRIPTION.....5

3 TEST METHODOLOGY.....6

3.1. DECISION OF FINAL TEST MODE.....6

3.2. EUT SYSTEM OPERATION.....6

4 SETUP OF EQUIPMENT UNDER TEST.....7

4.1. DESCRIPTION OF SUPPORT UNITS.....7

4.2. CONFIGURATION OF SYSTEM UNDER TEST8

5 FACILITIES AND ACCREDITATIONS.....9

5.1. FACILITIES9

5.2. ACCREDITATIONS.....9

5.3. MEASUREMENT UNCERTAINTY.....9

6 CONDUCTED EMISSION MEASUREMENT10

6.1. LIMITS OF CONDUCTED EMISSION MEASUREMENT10

6.2. TEST INSTRUMENTS10

6.3. TEST PROCEDURES.....11

6.4. TEST SETUP.....12

6.5. DATA SAMPLE12

6.6. TEST RESULTS.....13

7 RADIATED EMISSION MEASUREMENT.....14

7.1. LIMITS OF RADIATED EMISSION MEASUREMENT14

7.2. TEST INSTRUMENTS14

7.3. TEST PROCEDURES.....15

7.4. TEST SETUP.....17

7.5. DATA SAMPLE17

7.6. TEST RESULTS.....18

8 PHOTOGRAPHS OF THE TEST CONFIGURATION.....20



1 TEST RESULT CERTIFICATION

Product: PC/104 CPU Module

Brand: AAEON

Model: PFM-540I-B10-xxxxxx (Where x is 0-9 , A-Z , - or blank) for marketing purpose

Applicant: **AAEON Technology Inc.**
5F, No. 135, Lane 235, Pao Chiao Rd., Hsin-Tien City,
Taipei, Taiwan, R.O.C.

Manufacturer: **AAEON Technology Inc.**
5F, No. 135, Lane 235, Pao Chiao Rd., Hsin-Tien City,
Taipei, Taiwan, R.O.C.

Tested: March 20, 2008 ~ March 25, 2008

EMISSION			
Standard	Item	Result	Remarks
FCC 47 CFR Part 15 Subpart B, ICES-003 Issue 4 ANSI C63.4-2003	Conducted (Main Port)	PASS	Meet Class A limit
	Radiated	PASS	Meet Class A limit

Note: 1. The test result judgment is decided by the limit of measurement standard.
2. The information of measurement uncertainty is available upon the customer's request.

Deviation from Applicable Standard
None

The above equipment has been tested by Compliance Certification Services Inc., and found compliance with the requirements set forth in the technical standards mentioned above. The results of testing in this report apply only to the product/system, which was tested. Other similar equipment will not necessarily produce the same results due to production tolerance and measurement uncertainties.

Approved by:

Reviewed by:

Vince Chiang
Assistant Manager of Sindian BU.

Vesta Hsu
Supervisor of report document dept. of Sindian BU.



2 EUT DESCRIPTION

Product	PC/104 CPU Module
Brand Name	AAEON
Model	PFM-540I-B10-xxxxxx (Where x is 0-9 , A-Z , - or blank) for marketing purpose
Applicant	AAEON Technology Inc.
Housing material	N/A
Serial Number	N/A
Received Date	March 20, 2008
EUT Power Rating	5VDC
AC Power During Test	120VAC / 60Hz
OSC/Clock Frequencies	14.31818MHz; 25MHz; 32.768KHz

I/O PORT

I/O PORT TYPES	Q'TY	TESTED WITH
1) PIO Port	1	1
2) SIO Port	4	4
3) DB5 Pin Keyboard Port	1	1
4) PS/2 Mouse Port	1	1
5) VGA Port	1	1
6) USB Port	4	4
7) LAN Port	1	1

Note: Client consigns only one model sample to test (Model Number: PFM-540I-B10).



3 TEST METHODOLOGY

3.1. DECISION OF FINAL TEST MODE

The EUT was tested together with the above additional components, and a configuration, which produced the worst emission levels, was selected and recorded in this report.

The test configuration/ mode is as the following:

Conduction Mode :

1.	NORMAL MODE
----	-------------

Radiation Mode :

1.	NORMAL MODE
	NORMAL MODE / 1-5GHz

Conduction: Mode 1

Radiation: Mode 1

3.2. EUT SYSTEM OPERATION

1. Windows XP boots system.
2. Run Emctest.exe to activate all peripherals and display “H” pattern on monitor screen.
3. Run Winemc.exe and choose “F:/ & G:/ & H:/ & I:/” to test USB 2.0 ports.
4. Press the start menu, select executive and type ping 192.168.0.2-t (EUT), ping 192.168.0.1 -t (Server Notebook).

Note: Test program is self-repeating throughout the test.



4 SETUP OF EQUIPMENT UNDER TEST

4.1. DESCRIPTION OF SUPPORT UNITS

The EUT has been tested as an independent unit together with other necessary accessories or support units. The following support units or accessories were used to form a representative test configuration during the tests.

Hose PC Devices:

No.	Equipment	Model No.	Trade Name
1	CPU	Geode-GX 500MHZ	AMD
2	Hard Disk	ST340014A , 40GB	Seagate
3	Memory	DDR400 512MB / SAMSUNG/K4H510838D-UCCC	Transcend
4	Power Supply	ENH-0620	Enhance
5	Motherboard	PFM-540I-B10-xxxxxx (Where x is 0-9 , A-Z , - or blank) for marketing purpose	AAEON

Note: Client consigns only one model sample to test (Motherboard Model Number: PFM-540I-B10).

Peripherals Devices:

No.	Equipment	Model No.	Serial No.	FCC ID / BSMI ID	Trade Name	Data Cable	Power Cord
1	PS/2 Mouse	M-S34	LZE02905350	DZL211029	LOGITECH	Shielded, 1.8m	N/A
2	DB5 Pin Keyboard	5021	N/A	N/A	LEMEL	Shielded, 1.8m	N/A
3-6	USB 2.0 HDD X4	F12-U	N/A	BSMI ID: 4912A002	Terasys	Shielded, 1.8m	N/A
7-8	Modem X2	5JEG4033MKO	N/A	5RJTAI-35500-M5-E	TOP-SOLUTION	Unshielded, 1.8m	Unshielded, 1.8m
9	Printer	EPSON C60	DR3K039402	BSMI ID: 3902E006	EPSON	Shielded, 1.8m	Unshielded, 1.8m
10	Monitor	710V	GS17H9NXA05855D	DOC BSMI: R33475	SAMSUNG	Shielded, 1.8m with two cores	Unshielded, 1.8m
11-12	Modem X2	1414	N/A	IFAXDM1414	ACEEX	Unshielded, 1.8m	Unshielded, 1.8m
13	Server Notebook	M285	RD49R-7YTJR- B3C4K-G2JQX- DD3CG	DOC BSMI: R31259	LEO	Unshielded, 20m	Unshielded, 1.8m

Note:

- 1) All the equipment/cables were placed in the worst-case configuration to maximize the emission during the test.
- 2) Grounding was established in accordance with the manufacturer's requirements and conditions for the intended use.

4.2. CONFIGURATION OF SYSTEM UNDER TEST

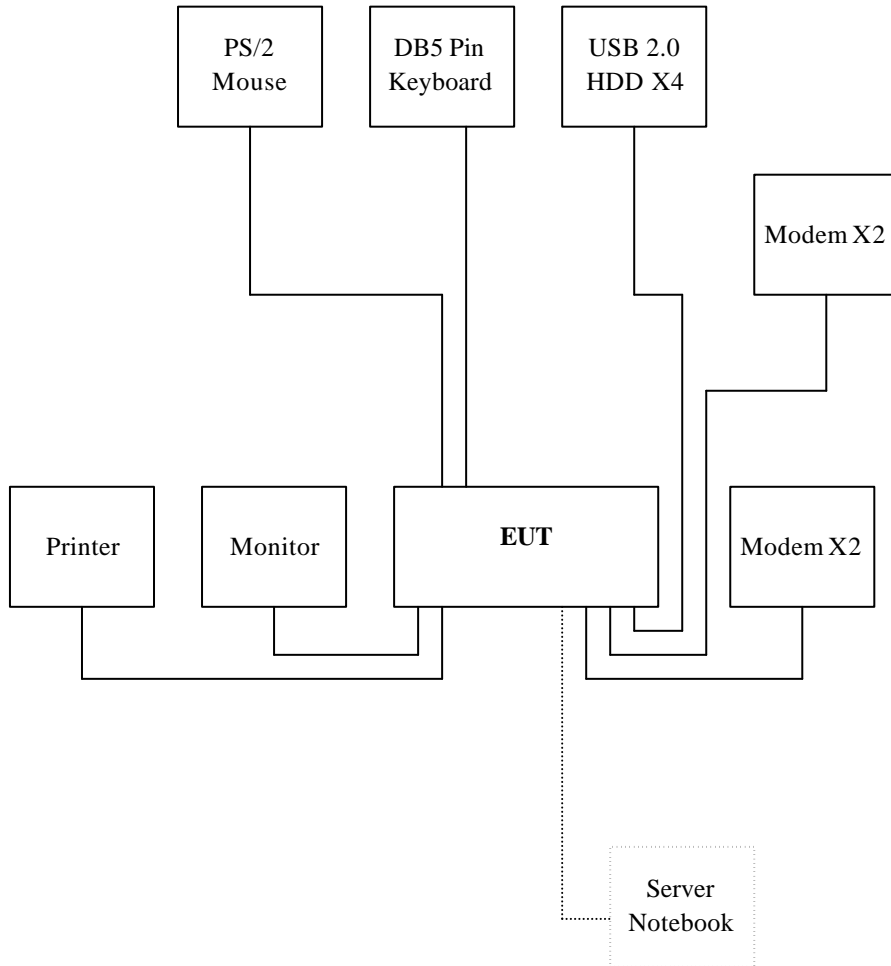

5 FACILITIES AND ACCREDITATIONS

5.1. FACILITIES

All measurement facilities used to collect the measurement data are located at CCS Taiwan Sindian BU. at No.163-1, Jhongsheng Rd., Sindian City, Taipei County 23151, Taiwan.

The sites are constructed in conformance with the requirements of ANSI C63.4 and CISPR Publication 22. All receiving equipment conforms to CISPR 16-1-1, CISPR 16-1-2, CISPR 16-1-3, CISPR 16-1-4 and CISPR 16-1-5.

5.2. ACCREDITATIONS

Our laboratories are accredited and approved by the following approval agencies according to ISO/IEC 17025.

USA	FCC, A2LA
Germany	TUV Rheinland
Japan	VCCI
Norway	NEMKO
Canada	INDUSTRY CANADA
Taiwan	TAF, BSMI

Copies of granted accreditation certificates are available for downloading from our web site, <http://www.ccsemc.com.tw>

5.3. MEASUREMENT UNCERTAINTY

Where relevant, the following measurement uncertainty levels have been estimated for tests performed on the EUT as specified in CISPR 16-4-2:

Measurement	Frequency	Uncertainty
Conducted emissions	9kHz~30MHz	± 1.7376
Radiated emissions	30MHz ~ 200MHz	± 3.8792
	200MHz ~1000MHz	± 3.8914

This uncertainty represents an expanded uncertainty expressed at approximately the 95% confidence level using a coverage factor of k=2.

Consistent with industry standard (e.g. CISPR 22: 2006, clause 11, Measurement Uncertainty) determining compliance with the limits shall be base on the results of the compliance measurement. Consequently the measure emissions being less than the maximum allowed emission result in this be a compliant test or passing test.

The acceptable measurement uncertainty value without requiring revision of the compliance statement is base on conducted and radiated emissions being less than U_{CISPR} which is 3.6dB and 5.2dB respectively. CCS values (called U_{Lab} in CISPR 16-4-2) is less than U_{CISPR} as shown in the table above. Therefore, MU need not be considered for compliance.



6 CONDUCTED EMISSION MEASUREMENT

6.1. LIMITS OF CONDUCTED EMISSION MEASUREMENT

FREQUENCY (MHz)	Class A (dBuV)		Class B (dBuV)	
	Quasi-peak	Average	Quasi-peak	Average
0.15 - 0.5	79	66	66 - 56	56 - 46
0.50 - 5.0	73	60	56	46
5.0 - 30.0	73	60	60	50

NOTE:

- (1) The lower limit shall apply at the transition frequencies.
- (2) The limit decreases in line with the logarithm of the frequency in the range of 0.15 to 0.50 MHz.
- (3) All emanations from a class A/B digital device or system, including any network of conductors and apparatus connected thereto, shall not exceed the level of field strengths specified above.

6.2. TEST INSTRUMENTS

Conducted Emission room # A				
Name of Equipment	Manufacturer	Model	Serial Number	Calibration Due
TEST RECEIVER	R&S	ESHS20	840455/006	02/18/2009
LISN (EUT)	SCHWARZBECK	NSLK 8127	8127382	12/03/2008
LISN	SOLAR	8012-50-R-24-BNC	8305114	12/03/2008
BNC CABLE	Huber+Suhner	RG-223/U	BNC A 2	05/13/2008
THERMO-HYGRO METER	TECPEL	DTM-303	No.7	11/15/2008
Test S/W	EMI 32.exe			

- NOTE:** 1. The calibration interval of the above test instruments is 12 months and the calibrations are traceable to NML/ROC and NIST/USA.
 2. N.C.R = No Calibration Request.



6.3. TEST PROCEDURES (please refer to measurement standard or CCS SOP PA -031)

Procedure of Preliminary Test

- The EUT and Support equipment, if needed, was set up as per the test configuration to simulate typical usage per the user's manual. When the EUT is a tabletop system, a wooden table with a height of 0.8 meters is used and is placed on the ground plane as per ANSI C63.4 (see Test Facility for the dimensions of the ground plane used). When the EUT is a floor standing equipment, it is placed on the ground plane, which has a 12 mm non-conductive covering to insulate the EUT from the ground plane.
- All I/O cables were positioned to simulate typical actual usage as per ANSI C63.4.
- The test equipment EUT installed received AC main power, through a Line Impedance Stabilization Network (LISN), which supplied power source and was grounded to the ground plane.
- All support equipment power received from a second LISN.
- The EUT test program was started. Emissions were measured on each current carrying line of the EUT using an EMI Test Receiver connected to the LISN powering the EUT.
- The Receiver scanned from 150kHz to 30MHz for emissions in each of the test modes.
- During the above scans, the emissions were maximized by cable manipulation.
- The test mode(s) described in Item 3.1 were scanned during the preliminary test.
- After the preliminary scan, we found the test mode described in Item 3.1 producing the highest emission level.
- The EUT configuration and cable configuration of the above highest emission levels were recorded for reference of the final test.

Procedure of Final Test

- EUT and support equipment were set up on the test bench as per the configuration with highest emission level in the preliminary test.
- A scan was taken on both power lines, Line 1 and Line 2, recording at least the six highest emissions. Emission frequency and amplitude were recorded into a computer in which correction factors were used to calculate the emission level and compare reading to the applicable limit.
- The test data of the worst-case condition(s) was recorded.

6.4. TEST SETUP

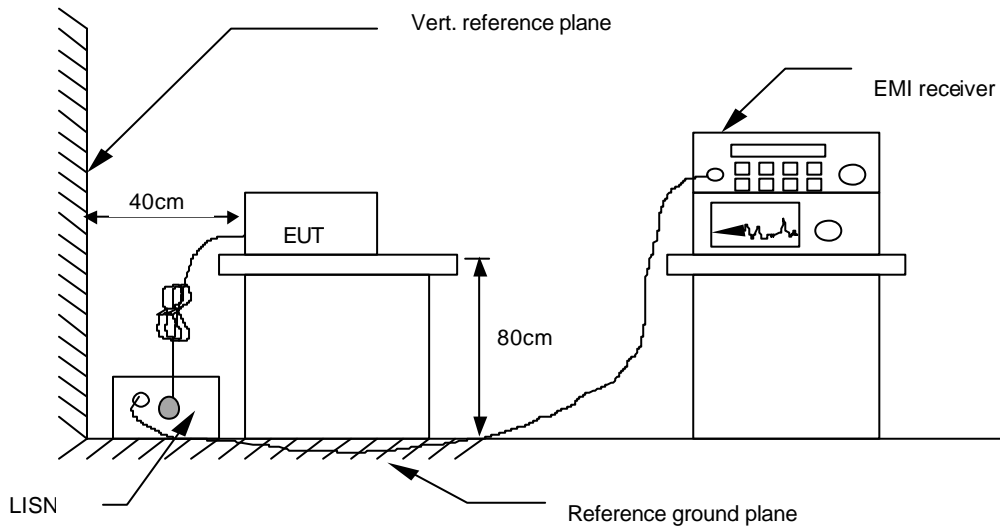

- For the actual test configuration, please refer to the related item – Photographs of the Test Configuration.

6.5. DATA SAMPLE

Freq. (MHz)	Read Level (dBuV)	Factor (dB)	Level (dBuV)	Limit Line (dBuV)	Over Limit (dB)	Remark (P/Q/A)	Line (L1/L2)
x.xx	42.95	0.55	43.50	73	-29.50	Q	L1

- Freq. = Emission frequency in MHz
- Read Level = Uncorrected Analyzer/Receiver reading
- Factor = Insertion loss of LISN + Cable Loss
- Level = Read Level + Factor
- Limit Line = Limit stated in standard
- Over Limit = Reading in reference to limit
- P = Peak Reading
- Q = Quasi-peak Reading
- A = Average Reading
- L1 = Hot side
- L2 = Neutral side

Calculation Formula

Over Limit (dB) = Level (dBuV) – Limit Line (dBuV)



6.6. TEST RESULTS

Model No.	PFM-540I-B10	6dB Bandwidth	10 KHz
Environmental Conditions	23°C, 55% RH, 1010mbar	Test Mode	Mode 1
Tested by	SAM SU		

(The chart below shows the highest readings taken from the final data.)

Six Highest Conducted Emission Readings							
Frequency Range Investigated				150 KHz to 30 MHz			
Freq. (MHz)	Read Level (dBuV)	Factor (dB)	Level (dBuV)	Limit Line (dBuV)	Over Limit (dB)	Remark (P/Q/A)	Line (L1/L2)
0.153	66.20	0.11	66.31	79.00	-12.69	P	L1
0.192	58.60	0.11	58.71	79.00	-20.29	P	L1
0.238	54.72	0.11	54.83	79.00	-24.17	P	L1
0.153	68.46	0.14	68.59	79.00	-10.41	P	L2
0.192	60.82	0.13	60.95	79.00	-18.05	P	L2
0.238	56.94	0.13	57.07	79.00	-21.93	P	L2

NOTE: 1. L1 = Line One (Live Line) / L2 = Line Two (Neutral Line).

2. The emission level was or more than 2dB below the Average limit, so no re-check anymore.



7 RADIATED EMISSION MEASUREMENT

7.1. LIMITS OF RADIATED EMISSION MEASUREMENT

FREQUENCY (MHz)	dBuV/m (At 10m)	
	Class A	Class B
30 ~ 230	40	30
230 ~ 1000	47	37

NOTE: (1) The lower limit shall apply at the transition frequencies.
 (2) Emission level (dBuV/m) = 20 log Emission level (uV/m).

7.2. TEST INSTRUMENTS

Open Area Test Site # I				
Name of Equipment	Manufacturer	Model	Serial Number	Calibration Due
SITE NSA	CCS	I Site	N/A	09/28/2008
MEASURE RECEIVER	SCHAFFNER	SCR3501	338	07/03/2008
SPECTRUM ANALYZER	ADVANTEST	R3132	120900008	No Calibration Required
ANTENNA	SCHAFFNER	CBL 6112B	2809	09/21/2008
AMPLIFIER	SCHAFFNER	CPA9231A	3626	10/10/2008
CABLE	BELDEN	9913	N-TYPE #I2	02/24/2009
ATTENUATOR	MCL	UNAT-6	AT06-3	10/10/2008
THERMO-HYGRO METER	TFA	N/A	NO.2	12/03/2008
Test S/W	Lab VIEW 7.1			
Above 1GHz Used				
EMC ANALYZER (100Hz-22GHz)	HP	8566B	2937A06102	07/29/2008
ANTENNA (1-18GHz)	EMCO	3115	00022256	01/30/2009
AMPLIFIER (1-18GHz)	HP	8449B	3008A01266	01/28/2009
CABLE (1-18GHz)	JYEBAO	LL142	SMA#RS1	01/28/2009
CABLE (1-18GHz)	HUBER +SUHNER	SUCOFLEX 104	SMA#RS3	01/28/2009
CABLE (1-18GHz)	JYEBAO	LL142	SMA#C1	01/28/2009
Test S/W	EMI 32.exe			

NOTE: 1. The calibration interval of the above test instruments is 12 months and the calibrations are traceable to NML/ROC and NIST/USA.
 2. N.C.R = No Calibration Request.



7.3. TEST PROCEDURES (please refer to measurement standard or CCS SOP PA -031)

Procedure of Preliminary Test

- The equipment was set up as per the test configuration to simulate typical usage per the user's manual. When the EUT is a tabletop system, a wooden turntable with a height of 0.8 meters is used which is placed on the ground plane. When the EUT is a floor standing equipment, it is placed on the ground plane which has a 12 mm non-conductive covering to insulate the EUT from the ground plane.
- Support equipment, if needed, was placed as per ANSI C63.4.
- All I/O cables were positioned to simulate typical usage as per ANSI C63.4.
- The EUT received AC power source from the outlet socket under the turntable. All support equipment power received from another socket under the turntable.
- The antenna was placed at 10 meter away from the EUT as stated in ANSI C63.4. The antenna connected to the Spectrum Analyzer via a cable and at times a pre-amplifier would be used.
- The Analyzer / Receiver quickly scanned from 30MHz to 5000MHz. The EUT test program was started. Emissions were scanned and measured rotating the EUT to 360 degrees and positioning the antenna 1 to 4 meters above the ground plane, in both the vertical and the horizontal polarization, to maximize the emission reading level.
- The test mode(s) described in Item 3.1 were scanned during the preliminary test:
- After the preliminary scan, we found the test mode described in Item 3.1 producing the highest emission level.
- The EUT and cable configuration, antenna position, polarization and turntable position of the above highest emission level were recorded for the final test.



Procedure of Final Test

- EUT and support equipment were set up on the turntable as per the configuration with highest emission level in the preliminary test.
- The Analyzer / Receiver scanned from 30MHz to 5000MHz. Emissions were scanned and measured rotating the EUT to 360 degrees, varying cable placement and positioning the antenna 1 to 4 meters above the ground plane, in both the vertical and the horizontal polarization, to maximize the emission reading level.
- Recorded at least the six highest emissions. Emission frequency, amplitude, antenna position, polarization and turntable position were recorded into a computer in which correction factors were used to calculate the emission level and compare reading to the applicable limit and only Q.P. reading is presented.
- The test data of the worst-case condition(s) was recorded.

7.4. TEST SETUP

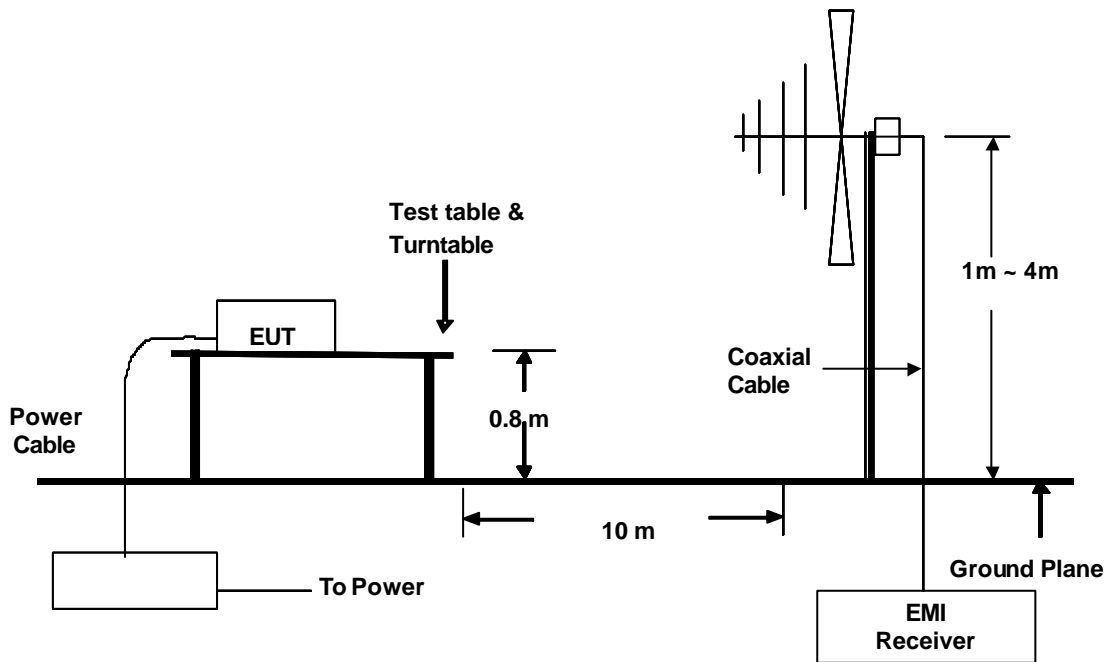

- For the actual test configuration, please refer to the related item – Photographs of the Test Configuration.

7.5. DATA SAMPLE

Freq. (MHz)	Reading (dBuV)	Factor (dB)	Result (dBuV/m)	Limit (dBuV/m)	Margin (dB)	Remark (P/Q/A)	Pol. (H/V)
x.xx	14.0	12.2	26.2	40	-13.8	Q	H

- Freq. = Emission frequency in MHz
- Reading = Uncorrected Analyzer/Receiver reading
- Factor = Antenna Factor + Cable Loss + Attenuator (3/6/10dB) – Amplifier Gain
- Result = Uncorrected Analyzer/Receiver reading + Factor
- Limit = Limit stated in standard
- Margin = Reading in reference to limit
- P = Peak Reading
- Q = Quasi-peak Reading
- A = Average Reading
- H = Antenna Polarization: Horizontal
- V = Antenna Polarization: Vertical

Calculation Formula

Margin (dB) = Level (dBuV/m) – Limit (dBuV/m)



7.6. TEST RESULTS

Model No.	PFM-540I-B10	Test Mode	Mode 1
Environmental Conditions	20°C, 70% RH, 1008mbar	6dB Bandwidth	100 KHz
Antenna Pole	Vertical	Antenna Distance	10m
Detector Function	Quasi-peak.	Tested by	ALEX PAN

(The chart below shows the highest readings taken from the final data.)

Six Highest Radiated Emission Readings							
Frequency Range Investigated				30 MHz to 1000 MHz at 10m			
Freq. (MHz)	Reading (dBuV)	Factor (dB)	Result (dBuV/m)	Limit (dBuV/m)	Margin (dB)	Remark (P/Q/A)	Pol. (H/V)
52.240	49.20	-14.28	34.92	40.00	-5.08	Q	V
111.000	45.42	-10.07	35.35	40.00	-4.65	Q	V
117.540	45.30	-9.50	35.80	40.00	-4.20	Q	V
150.040	43.24	-10.40	32.83	40.00	-7.16	Q	V
208.890	43.82	-10.27	33.56	40.00	-6.45	Q	V
299.630	50.00	-6.40	43.60	47.00	-3.40	Q	V

- REMARKS:**
1. 30MHz to 1000MHz test is Applicable CISPR 22 / EN 55022 standard.
 2. The other emission levels were very low against the limit.
 3. P= Peak Reading; Q= Quasi-peak Reading A= Average Reading.



Model No.	PFM-540I-B10	Test Mode	Mode 1
Environmental Conditions	20°C, 70% RH, 1008mbar	6dB Bandwidth	100 KHz
Antenna Pole	Horizontal	Antenna Distance	10m
Detector Function	Quasi-peak.	Tested by	ALEX PAN

(The chart below shows the highest readings taken from the final data.)

Six Highest Radiated Emission Readings							
Frequency Range Investigated				30 MHz to 1000 MHz at 10m			
Freq. (MHz)	Reading (dBuV)	Factor (dB)	Result (dBuV/m)	Limit (dBuV/m)	Margin (dB)	Remark (P/Q/A)	Pol. (H/V)
52.200	42.82	-14.27	28.55	40.00	-11.45	Q	H
117.510	43.95	-9.51	34.44	40.00	-5.55	Q	H
150.340	43.41	-10.41	33.00	40.00	-7.00	Q	H
192.610	42.45	-11.47	30.98	40.00	-9.02	Q	H
237.810	44.70	-8.46	36.24	47.00	-10.76	Q	H
299.640	49.10	-6.40	42.70	47.00	-4.30	Q	H

- REMARKS:**
1. 30MHz to 1000MHz test is Applicable CISPR 22 / EN 55022 standard.
 2. The other emission levels were very low against the limit.
 3. P= Peak Reading; Q= Quasi-peak Reading A= Average Reading.

8 PHOTOGRAPHS OF THE TEST CONFIGURATION CONDUCTED EMISSION TEST



RADIATED EMISSION TEST

