

FCC DoC TEST REPORT

for

Industrial Monitor

MODEL: xxxxxOPD-215EBT-xxxxxxx

Test Report Number:
80919209-F

Issued to:

AAEON Technology Inc.

**5F, No. 135, Lane 235, Pao Chiao Rd., Hsin-Tien City,
Taipei, Taiwan, R.O.C.**

Issued by:

Compliance Certification Services Inc.

Sindian BU.

**No.163-1, Jhongsheng Rd., Sindian City,
Taipei County 23151, Taiwan**

TEL: 886-2-22170894

FAX: 886-2-22171029

Issued Date: October 03, 2008



***Note:** This report shall not be reproduced except in full, without the written approval of Compliance Certification Services Inc. This document may be altered or revised by Compliance Certification Services Inc. personnel only, and shall be noted in the revision section of the document. The client should not use it to claim product endorsement by TAF, A2LA, NVLAP, NIST or any government agencies. The test results in the report only apply to the tested sample.*



Revision History

Rev.	Issue Date	Revisions	Effect Page	Revised By
00		Initial Issue	ALL	



TABLE OF CONTENTS

1 TEST RESULT CERTIFICATION..... 4

2 EUT DESCRIPTION..... 5

3 TEST METHODOLOGY 6

3.1. DECISION OF FINAL TEST MODE 6

3.2. EUT SYSTEM OPERATION..... 6

4 SETUP OF EQUIPMENT UNDER TEST 7

4.1. DESCRIPTION OF SUPPORT UNITS 7

4.2. CONFIGURATION OF SYSTEM UNDER TEST 8

5 FACILITIES AND ACCREDITATIONS 9

5.1. FACILITIES..... 9

5.2. ACCREDITATIONS 9

5.3. MEASUREMENT UNCERTAINTY 9

6 CONDUCTED EMISSION MEASUREMENT..... 10

6.1. LIMITS OF CONDUCTED EMISSION MEASUREMENT 10

6.2. TEST INSTRUMENTS 10

6.3. TEST PROCEDURES..... 11

6.4. TEST SETUP..... 12

6.5. DATA SAMPLE..... 12

6.6. TEST RESULTS 13

7 RADIATED EMISSION MEASUREMENT 14

7.1. LIMITS OF RADIATED EMISSION MEASUREMENT 14

7.2. TEST INSTRUMENTS 14

7.3. TEST PROCEDURES..... 15

7.4. TEST SETUP..... 17

7.5. DATA SAMPLE..... 17

7.6. TEST RESULTS 18

8 PHOTOGRAPHS OF THE TEST CONFIGURATION 20



1 TEST RESULT CERTIFICATION

Product: Industrial Monitor

Brand: AAEON

Model: xxxxxOPD-215EBT-xxxxxxx (Where B or blank for bezel selection, T or blank for touch screen and x is 0-9 , A-Z , -or blank) for marketing purpose

Applicant: **AAEON Technology Inc.**
5F, No. 135, Lane 235, Pao Chiao Rd., Hsin-Tien City,
Taipei, Taiwan, R.O.C.

Manufacturer: **AAEON Technology Inc.**
5F, No. 135, Lane 235, Pao Chiao Rd., Hsin-Tien City,
Taipei, Taiwan, R.O.C.

Tested: September 19, 2008 & September 24, 2008

EMISSION			
Standard	Item	Result	Remarks
FCC 47 CFR Part 15 Subpart B, ICES-003 Issue 4 ANSI C63.4-2003	Conducted (Main Port)	PASS	Meet Class A limit
	Radiated	PASS	Meet Class A limit

Note: 1. The test result judgment is decided by the limit of measurement standard.
2. The information of measurement uncertainty is available upon the customer's request.

Deviation from Applicable Standard
None

The above equipment has been tested by Compliance Certification Services Inc., and found compliance with the requirements set forth in the technical standards mentioned above. The results of testing in this report apply only to the product/system, which was tested. Other similar equipment will not necessarily produce the same results due to production tolerance and measurement uncertainties.

Approved by:

Reviewed by:

Vince Chiang
Assistant Manager of Sindian BU.

Vesta Hsu
Supervisor of report document dept. of Sindian BU.



2 EUT DESCRIPTION

Product	Industrial Monitor
Brand Name	AAEON
Model	xxxxxOPD-215EBT-xxxxxxx (Where B or blank for bezel selection, T or blank for touch screen and x is 0-9 , A-Z , -or blank) for marketing purpose
Applicant	AAEON Technology Inc.
Housing material	N/A
Serial Number	N/A
Received Date	September 19, 2008
EUT Power Rating	12VDC from AC Adaptor
AC Power During Test	120VAC / 60 Hz to AC Adaptor
AC Adaptor Manufacturer	EDACPOWER ELEC.
AC Adaptor Model Number	EA-1050A-120
Power Adaptor Power Rating	IP: 100-240VAC, 50-60Hz OP: 12VDC
DC Power Cord Type	Unshielded, 1.2m (Non-Detachable, with a core) to AC Adaptor
EUT I/O Cable Type	Unshielded, 1.8m (Detachable)
OSC/Clock Frequencies	14.318MHz; 16MHz

I/O PORT

I/O PORT TYPES	Q'TY	TESTED WITH
1) SIO Port	1	1
2) VGA Port	1	1
3) DVI Port	1	1

Note: Client consigns only one model sample to test (Model Number: OPD-215EBT).

3 TEST METHODOLOGY

3.1. DECISION OF FINAL TEST MODE

The EUT was tested together with the above additional components, and a configuration, which produced the worst emission levels, was selected and recorded in this report.

The test configuration/ modes is as the following:

Modes:

1.	D-SUB MODE
2.	DVI MODE

Conduction: Mode 1

Radiation: Mode 2

3.2. EUT SYSTEM OPERATION

1. Windows XP boots system.
2. Run Emctest.exe to activate all peripherals and display “H” pattern on monitor screen.

Note: Test program is self-repeating throughout the test.



4 SETUP OF EQUIPMENT UNDER TEST

4.1. DESCRIPTION OF SUPPORT UNITS

The EUT has been tested as an independent unit together with other necessary accessories or support units. The following support units or accessories were used to form a representative test configuration during the tests.

Peripherals Devices:

No.	Equipment	Model No.	Serial No.	FCC ID / BSMI ID	Trade Name	Data Cable	Power Cord
1	PS/2 Mouse	M071KC	443029438	DOC BSMI: R41108	DELL	Shielded, 1.8m	N/A
2	PS/2 Keyboard	SK-8110	N/A	DOC BSMI: T3A002	DELL	Shielded, 1.8m	N/A
3	Host PC	xw4400	N/A	DOC BSMI: R33001	HP	D-SUB: Shielded, 1.8m with two cores DVI: Shielded, 1.8m with two cores RS-232: Unshielded, 1.8m	Unshielded, 1.8m
4	Printer	Deskjet D2360	TH73C1492F	DOC BSMI: R33001	HP	Shielded, 1.8m	Unshielded, 1.8m

Note:

- 1) All the equipment/cables were placed in the worst-case configuration to maximize the emission during the test.
- 2) Grounding was established in accordance with the manufacturer's requirements and conditions for the intended use.

4.2. CONFIGURATION OF SYSTEM UNDER TEST

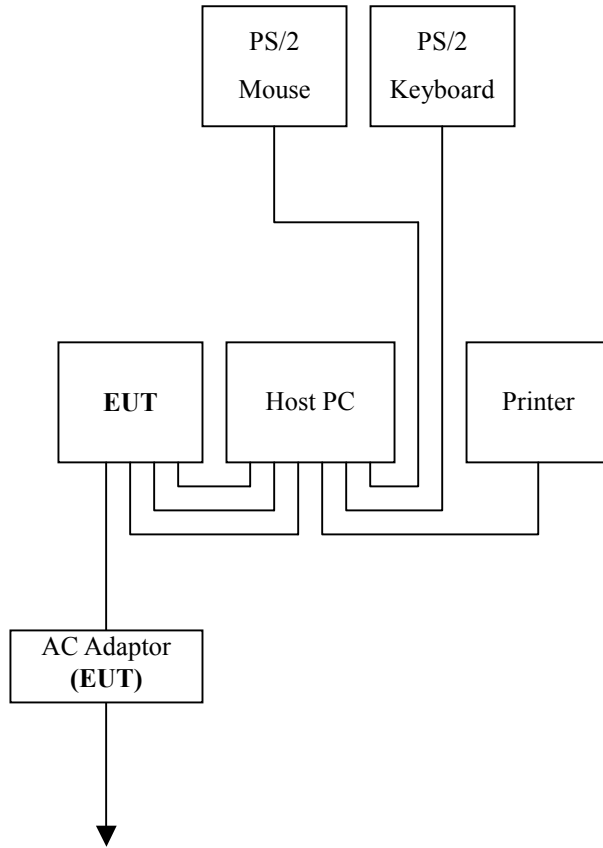

5 FACILITIES AND ACCREDITATIONS

5.1. FACILITIES

All measurement facilities used to collect the measurement data are located at CCS Taiwan Sindian BU. at No.163-1, Jhongsheng Rd., Sindian City, Taipei County 23151, Taiwan.

The sites are constructed in conformance with the requirements of ANSI C63.4 and CISPR Publication 22. All receiving equipment conforms to CISPR 16-1-1, CISPR 16-1-2, CISPR 16-1-3, CISPR 16-1-4 and CISPR 16-1-5.

5.2. ACCREDITATIONS

Our laboratories are accredited and approved by the following accreditation body according to ISO/IEC 17025.

Taiwan	TAF
USA	A2LA

The measuring facility of laboratories has been authorized or registered by the following approval agencies.

Canada	Industry Canada
Germany	TUV Rheinland
Japan	VCCI
Taiwan	BSMI
USA	FCC

Copies of granted accreditation certificates are available for downloading from our web site, <http://www.ccsemc.com.tw>

5.3. MEASUREMENT UNCERTAINTY

Where relevant, the following measurement uncertainty levels have been estimated for tests performed on the EUT as specified in CISPR 16-4-2:

Measurement	Frequency	Uncertainty
Conducted emissions	0.15MHz~30MHz	± 1.7376
Radiated emissions	30MHz ~ 200MHz	± 3.8773
	200MHz ~1000MHz	± 3.8820

This uncertainty represents an expanded uncertainty expressed at approximately the 95% confidence level using a coverage factor of k=2.

Consistent with industry standard (e.g. CISPR 22: 2006, clause 11, Measurement Uncertainty) determining compliance with the limits shall be base on the results of the compliance measurement. Consequently the measure emissions being less than the maximum allowed emission result in this be a compliant test or passing test.

The acceptable measurement uncertainty value without requiring revision of the compliance statement is base on conducted and radiated emissions being less than U_{CISPR} which is 3.6dB and 5.2dB respectively. CCS values (called U_{Lab} in CISPR 16-4-2) is less than U_{CISPR} as shown in the table above. Therefore, MU need not be considered for compliance.



6 CONDUCTED EMISSION MEASUREMENT

6.1. LIMITS OF CONDUCTED EMISSION MEASUREMENT

FREQUENCY (MHz)	Class A (dBuV)		Class B (dBuV)	
	Quasi-peak	Average	Quasi-peak	Average
0.15 - 0.5	79	66	66 - 56	56 - 46
0.50 - 5.0	73	60	56	46
5.0 - 30.0	73	60	60	50

NOTE:

- (1) The lower limit shall apply at the transition frequencies.
- (2) The limit decreases in line with the logarithm of the frequency in the range of 0.15 to 0.50 MHz.
- (3) All emanations from a class A/B digital device or system, including any network of conductors and apparatus connected thereto, shall not exceed the level of field strengths specified above.

6.2. TEST INSTRUMENTS

Conducted Emission room # A				
Name of Equipment	Manufacturer	Model	Serial Number	Calibration Due
TEST RECEIVER	R&S	ESHS20	840455/006	02/18/2009
LISN (EUT)	SCHWARZBECK	NSLK 8127	8127382	12/03/2008
LISN	SOLAR	8012-50-R-24-BNC	8305114	12/03/2008
BNC CABLE	MIYAZAKI	5D-FB	BNC A4	05/12/2009
THERMO-HYGRO METER	TECPEL	DTM-303	No.7	11/15/2008
Test S/W	EMI 32.exe			

- NOTE:** 1. The calibration interval of the above test instruments is 12 months and the calibrations are traceable to NML/ROC and NIST/USA.
 2. N.C.R = No Calibration Request.



6.3. TEST PROCEDURES (please refer to measurement standard or CCS SOP PA-031)

Procedure of Preliminary Test

- The EUT and Support equipment, if needed, was set up as per the test configuration to simulate typical usage per the user's manual. When the EUT is a tabletop system, a wooden table with a height of 0.8 meters is used and is placed on the ground plane as per ANSI C63.4 (see Test Facility for the dimensions of the ground plane used). When the EUT is a floor standing equipment, it is placed on the ground plane, which has a 3-12 mm non-conductive covering to insulate the EUT from the ground plane.
- All I/O cables were positioned to simulate typical actual usage as per ANSI C63.4.
- The test equipment EUT installed received AC main power, through a Line Impedance Stabilization Network (LISN), which supplied power source and was grounded to the ground plane.
- All support equipment power received from a second LISN.
- The EUT test program was started. Emissions were measured on each current carrying line of the EUT using an EMI Test Receiver connected to the LISN powering the EUT.
- The Receiver scanned from 150kHz to 30MHz for emissions in each of the test modes.
- During the above scans, the emissions were maximized by cable manipulation.
- The test mode(s) described in Item 3.1 were scanned during the preliminary test.
- After the preliminary scan, we found the test mode described in Item 3.1 producing the highest emission level.
- The EUT configuration and cable configuration of the above highest emission levels were recorded for reference of the final test.

Procedure of Final Test

- EUT and support equipment were set up on the test bench as per the configuration with highest emission level in the preliminary test.
- A scan was taken on both power lines, Line 1 and Line 2, recording at least the six highest emissions. Emission frequency and amplitude were recorded into a computer in which correction factors were used to calculate the emission level and compare reading to the applicable limit.
- The test data of the worst-case condition(s) was recorded.

6.4. TEST SETUP

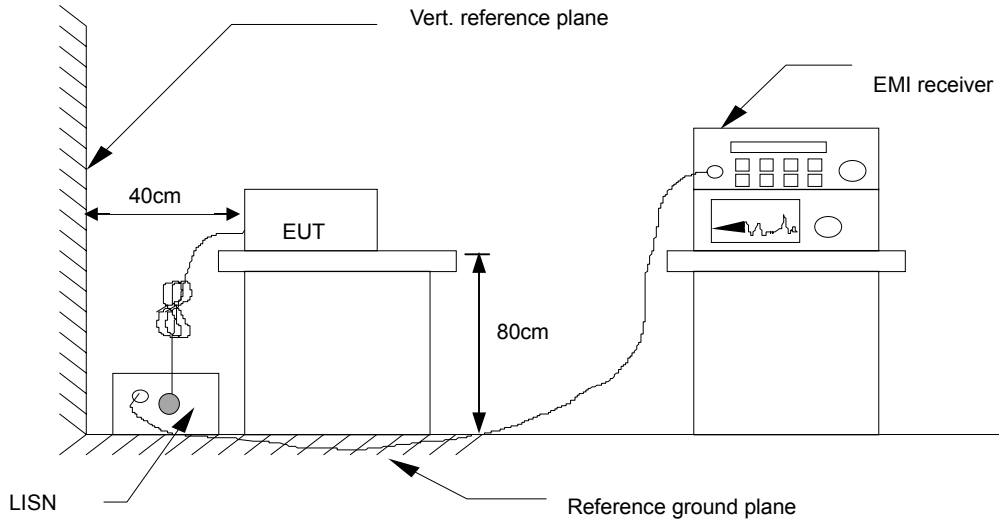

- For the actual test configuration, please refer to the related item – Photographs of the Test Configuration.

6.5. DATA SAMPLE

Freq. (MHz)	Read Level (dBuV)	Factor (dB)	Level (dBuV)	Limit Line (dBuV)	Over Limit (dB)	Remark (P/Q/A)	Line (L1/L2)
x.xx	42.95	0.55	43.50	73	-29.50	Q	L1

- Freq. = Emission frequency in MHz
- Read Level = Uncorrected Analyzer/Receiver reading
- Factor = Insertion loss of LISN + Cable Loss
- Level = Read Level + Factor
- Limit Line = Limit stated in standard
- Over Limit = Reading in reference to limit
- P = Peak Reading
- Q = Quasi-peak Reading
- A = Average Reading
- L1 = Hot side
- L2 = Neutral side

Calculation Formula

Over Limit (dB) = Level (dBuV) – Limit Line (dBuV)



6.6. TEST RESULTS

Model No.	OPD-215EBT	6dB Bandwidth	10 KHz
Environmental Conditions	24°C, 59% RH, 1010mbar	Test Mode	Mode 1
Tested by	Webber Chung		

(The chart below shows the highest readings taken from the final data.)

Six Highest Conducted Emission Readings							
Frequency Range Investigated				150 KHz to 30 MHz			
Freq. (MHz)	Read Level (dBuV)	Factor (dB)	Level (dBuV)	Limit Line (dBuV)	Over Limit (dB)	Remark (P/Q/A)	Line (L1/L2)
0.151	50.21	0.12	50.33	79.00	-28.67	P	L1
0.182	60.77	0.12	60.89	79.00	-18.11	P	L1
0.242	50.23	0.12	50.35	79.00	-28.65	P	L1
0.151	49.25	0.15	49.40	79.00	-29.60	P	L2
0.182	58.21	0.14	58.35	79.00	-20.65	P	L2
0.239	48.33	0.14	48.47	79.00	-30.53	P	L2

NOTE: 1. L1 = Line One (Live Line) / L2 = Line Two (Neutral Line).

2. The emission level was or more than 2dB below the Average limit, so no re-check anymore.



7 RADIATED EMISSION MEASUREMENT

7.1. LIMITS OF RADIATED EMISSION MEASUREMENT

FREQUENCY (MHz)	dBuV/m (At 10m)	
	Class A	Class B
30 ~ 230	40	30
230 ~ 1000	47	37

NOTE: (1) The lower limit shall apply at the transition frequencies.
 (2) Emission level (dBuV/m) = 20 log Emission level (uV/m).

7.2. TEST INSTRUMENTS

Open Area Test Site # J				
Name of Equipment	Manufacturer	Model	Serial Number	Calibration Due
MEASURE RECEIVER	SCHAFFNER	SCR3501	330	06/09/2009
SPECTRUM ANALYZER	AGILENT	E4411B	MY41440176	No Calibration Required
ANTENNA	SCHAFFNER	CBL 6112B	2800	09/09/2009
PRE-AMPLIFIER	SCHAFFNER	CPA9231A	3629	10/10/2008
CABLE	BELDEN	9913	N-TYPE #J3	01/23/2009
ATTENUATOR	MCL	UNAT-6	AT06-8	12/02/2008
THERMO-HYGRO METER	TECPEL	DTM-303	NO.3	11/15/2008
Test S/W	EZ-EMC			

NOTE: 1. The calibration interval of the above test instruments is 12 months and the calibrations are traceable to NML/ROC and NIST/USA.
 2. N.C.R = No Calibration Request.



7.3. TEST PROCEDURES (please refer to measurement standard or CCS SOP PA-031)

Procedure of Preliminary Test

- The equipment was set up as per the test configuration to simulate typical usage per the user's manual. When the EUT is a tabletop system, a wooden turntable with a height of 0.8 meters is used which is placed on the ground plane. When the EUT is a floor standing equipment, it is placed on the ground plane which has a 3-12 mm non-conductive covering to insulate the EUT from the ground plane.
- Support equipment, if needed, was placed as per ANSI C63.4.
- All I/O cables were positioned to simulate typical usage as per ANSI C63.4.
- The EUT received AC power source from the outlet socket under the turntable. All support equipment power received from another socket under the turntable.
- The antenna was placed at 10 meter away from the EUT as stated in ANSI C63.4. The antenna connected to the Spectrum Analyzer via a cable and at times a pre-amplifier would be used.
- The Analyzer / Receiver quickly scanned from 30MHz to 1000MHz. The EUT test program was started. Emissions were scanned and measured rotating the EUT to 360 degrees and positioning the antenna 1 to 4 meters above the ground plane, in both the vertical and the horizontal polarization, to maximize the emission reading level.
- The test mode(s) described in Item 3.1 were scanned during the preliminary test:
- After the preliminary scan, we found the test mode described in Item 3.1 producing the highest emission level.
- The EUT and cable configuration, antenna position, polarization and turntable position of the above highest emission level were recorded for the final test.



Procedure of Final Test

- EUT and support equipment were set up on the turntable as per the configuration with highest emission level in the preliminary test.
- The Analyzer / Receiver scanned from 30MHz to 1000MHz. Emissions were scanned and measured rotating the EUT to 360 degrees, varying cable placement and positioning the antenna 1 to 4 meters above the ground plane, in both the vertical and the horizontal polarization, to maximize the emission reading level.
- Recorded at least the six highest emissions. Emission frequency, amplitude, antenna position, polarization and turntable position were recorded into a computer in which correction factors were used to calculate the emission level and compare reading to the applicable limit and only Q.P. reading is presented.
- The test data of the worst-case condition(s) was recorded.

7.4. TEST SETUP

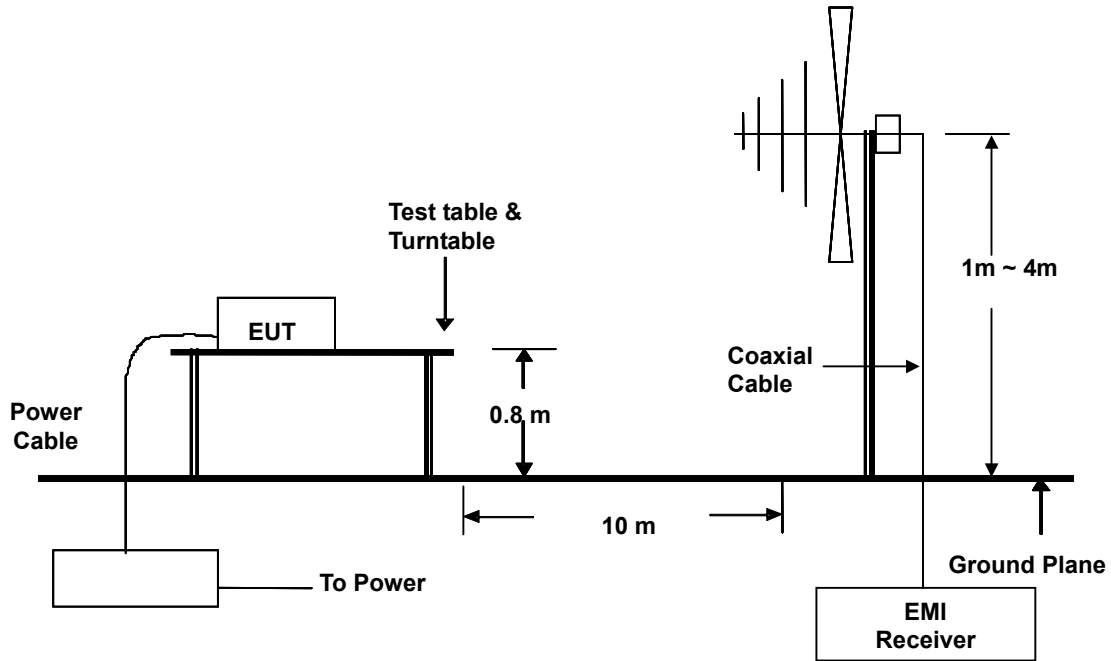

- For the actual test configuration, please refer to the related item - Photographs of the Test Configuration.

7.5. DATA SAMPLE

Freq. (MHz)	Reading (dBUV)	Factor (dB)	Result (dBUV/m)	Limit (dBUV/m)	Margin (dB)	Remark (P/Q/A)	Pol. (H/V)
x.xx	14.0	12.2	26.2	40	-13.8	Q	H

- Freq. = Emission frequency in MHz
- Reading = Uncorrected Analyzer/Receiver reading
- Factor = Antenna Factor + Cable Loss + Attenuator (3/6/10dB) – Amplifier Gain
- Result = Uncorrected Analyzer/Receiver reading + Factor
- Limit = Limit stated in standard
- Margin = Reading in reference to limit
- P = Peak Reading
- Q = Quasi-peak Reading
- A = Average Reading
- H = Antenna Polarization: Horizontal
- V = Antenna Polarization: Vertical

Calculation Formula

Margin (dB) = Level (dBUV/m) – Limit (dBUV/m)



7.6. TEST RESULTS

Model No.	OPD-215EBT	Test Mode	Mode 1
Environmental Conditions	31°C, 58% RH, 1010mbar	6dB Bandwidth	120 KHz
Antenna Pole	Vertical	Antenna Distance	10m
Detector Function	Quasi-peak.	Tested by	Stanley Cheng

(The chart below shows the highest readings taken from the final data.)

Six Highest Radiated Emission Readings							
Frequency Range Investigated				30 MHz to 1000 MHz at 10m			
Freq. (MHz)	Reading (dBuV)	Factor (dB)	Result (dBuV/m)	Limit (dBuV/m)	Margin (dB)	Remark (P/Q/A)	Pol. (H/V)
110.9700	38.60	-10.74	27.86	40.00	-12.14	Q	V
130.0500	42.40	-11.24	31.16	40.00	-8.84	Q	V
390.1500	43.40	-3.24	40.16	47.00	-6.84	Q	V
455.1200	39.90	-2.33	37.57	47.00	-9.43	Q	V
669.2600	36.50	0.90	37.40	47.00	-9.60	Q	V
691.7400	34.90	0.59	35.49	47.00	-11.51	Q	V

- REMARKS:**
1. 30MHz to 1000MHz test is Applicable CISPR 22 / EN 55022 standard.
 2. The other emission levels were very low against the limit.
 3. P= Peak Reading; Q= Quasi-peak Reading A= Average Reading.



Model No.	OPD-215EBT	Test Mode	Mode 1
Environmental Conditions	31°C, 58% RH, 1010mbar	6dB Bandwidth	120 KHz
Antenna Pole	Horizontal	Antenna Distance	10m
Detector Function	Quasi-peak.	Tested by	Stanley Cheng

(The chart below shows the highest readings taken from the final data.)

Six Highest Radiated Emission Readings							
Frequency Range Investigated				30 MHz to 1000 MHz at 10m			
Freq. (MHz)	Reading (dBuV)	Factor (dB)	Result (dBuV/m)	Limit (dBuV/m)	Margin (dB)	Remark (P/Q/A)	Pol. (H/V)
130.0200	38.80	-11.24	27.56	40.00	-12.44	Q	H
219.4800	38.40	-11.25	27.15	40.00	-12.85	Q	H
390.1800	40.60	-3.24	37.36	47.00	-9.64	Q	H
455.1400	43.40	-2.33	41.07	47.00	-5.93	Q	H
657.2600	38.70	1.06	39.76	47.00	-7.24	Q	H
669.2500	36.10	0.90	37.00	47.00	-10.00	Q	H

- REMARKS:**
1. 30MHz to 1000MHz test is Applicable CISPR 22 / EN 55022 standard.
 2. The other emission levels were very low against the limit.
 3. P= Peak Reading; Q= Quasi-peak Reading A= Average Reading.

**8 PHOTOGRAPHS OF THE TEST CONFIGURATION
CONDUCTED EMISSION TEST**



RADIATED EMISSION TEST

