



FCC Verification TEST REPORT

for

Fanless Medical Station

**MODEL: xxxxxONYX-1722DTy-xxxxxxx;
xxxxxONYX-1922DTy-xxxxxxx**

Test Report Number:
90623201-D

Issued to:

AAEON Technology Inc.

**5F, No.135, Lane 235, Pao Chiao Rd., Hsin-Tien City,
Taipei, Taiwan, R.O.C.**

Issued by:

Compliance Certification Services Inc.

Sindian BU.

**No.163-1, Jhongsheng Rd., Sindian City,
Taipei County 23151, Taiwan**

TEL: 886-2-22170894

FAX: 886-2-22171029

Issued Date: June 26, 2009



Note: This report shall not be reproduced except in full, without the written approval of Compliance Certification Services Inc. This document may be altered or revised by Compliance Certification Services Inc. personnel only, and shall be noted in the revision section of the document. The client should not use it to claim product endorsement by TAF, A2LA, NVLAP, NIST or any government agencies. The test results in the report only apply to the tested sample.



Revision History

Rev.	Issue Date	Revisions	Effect Page	Revised By
00		Initial Issue	ALL	



TABLE OF CONTENTS

1 TEST RESULT CERTIFICATION..... 4

2 EUT DESCRIPTION..... 5

3 TEST METHODOLOGY 6

3.1. DECISION OF FINAL TEST MODE..... 6

3.2. EUT SYSTEM OPERATION 7

4 SETUP OF EQUIPMENT UNDER TEST 7

4.1. DESCRIPTION OF SUPPORT UNITS 7

4.2. CONFIGURATION OF SYSTEM UNDER TEST..... 8

5 FACILITIES AND ACCREDITATIONS 9

5.1. FACILITIES 9

5.2. ACCREDITATIONS 9

5.3. MEASUREMENT UNCERTAINTY 9

6 CONDUCTED EMISSION MEASUREMENT..... 10

6.1. LIMITS OF CONDUCTED EMISSION MEASUREMENT 10

6.2. TEST INSTRUMENTS 10

6.3. TEST PROCEDURES 11

6.4. TEST SETUP 12

6.5. DATA SAMPLE..... 12

6.6. TEST RESULTS..... 13

7 RADIATED EMISSION MEASUREMENT 14

7.1. LIMITS OF RADIATED EMISSION MEASUREMENT 14

7.2. TEST INSTRUMENTS 14

7.3. TEST PROCEDURES 15

7.4. TEST SETUP 16

7.5. DATA SAMPLE..... 17

7.6. TEST RESULTS..... 18

8 PHOTOGRAPHS OF THE TEST CONFIGURATION 20



1 TEST RESULT CERTIFICATION

Product: Fanless Medical Station

Brand: AAEON

Model: xxxxxONYX-1722DTy-xxxxxxx (Where y is T or blank and x is 0-9, A-Z, - or blank);
xxxxxONYX-1922DTy-xxxxxxx (Where y is T or blank and x is 0-9, A-Z, - or blank)

Applicant: **AAEON Technology Inc.**
5F, No.135, Lane 235, Pao Chiao Rd., Hsin-Tien City,
Taipei, Taiwan, R.O.C.

Manufacturer: **AAEON Technology Inc.**
5F, No.135, Lane 235, Pao Chiao Rd., Hsin-Tien City,
Taipei, Taiwan, R.O.C.

Tested: June 05, 2009 ~ June 23, 2009

Applicable Standard	Class / Limit	Test Result
FCC Part 18	---	No non-compliance noted
Deviation from Applicable Standard		
None		

*Note: 1. The statements of test result on the above are decided by the request of test standard only; the measurement uncertainties are not factored into this compliance determination.
2. The information of measurement uncertainty is available upon the customer's request.*

Deviation from Applicable Standard
None

The above equipment has been tested by Compliance Certification Services Inc., and found compliance with the requirements set forth in the technical standards mentioned above. The results of testing in this report apply only to the product/system, which was tested. Other similar equipment will not necessarily produce the same results due to production tolerance and measurement uncertainties.

Approved by:

Reviewed by:

Vince Chiang
Assistant Manager of Sindian BU.

Vesta Hsu
Supervisor of report document dept. of Sindian BU.



2 EUT DESCRIPTION

Product	Fanless Medical Station
Trade Name	AAEON
Model	xxxxxONYX-1722DTy-xxxxxxx (Where y is T or blank and x is 0-9, A-Z, - or blank); xxxxxONYX-1922DTy-xxxxxxx (Where y is T or blank and x is 0-9, A-Z, - or blank)
Applicant	AAEON Technology Inc.
Housing Type	Plastic w/ metal plate
Received Date	June 23, 2009
EUT Power Rating	9~30VDC from AC Adaptor
AC Power During Test	120VAC / 60 Hz to AC Adaptor
AC Adaptor Manufacturer	PROTEK POWER
AC Adaptor Model Number	PMP120-14-B16
Power Adaptor Power Rating	I/P: 100~240VAC; O/P: 24V/5A
AC Power Cable Type	Unshielded, 1.8m (Detachable) to Power Adaptor
DC Power Cable Type	Unshielded, 1.2m (Non-detachable, with a core) to AC Adaptor
OSC/Clock Frequencies	25MHz; 14.31818MHz; 32.768kHz
EUT I/O Cable Type	Unshielded, 0.1m (Detachable)

Model Differences:

Model Name	Difference	Tested (Checked)
xxxxxONYX-1722DTy-xxxxxxx (Where y is T or blank and x is 0-9, A-Z, - or blank)	17" Panel	<input checked="" type="checkbox"/>
xxxxxONYX-1922DTy-xxxxxxx (Where y is T or blank and x is 0-9, A-Z, - or blank)	19" Panel	<input checked="" type="checkbox"/>

I/O PORT (Model: ONYX-1722DT)

I/O PORT TYPES	Q'TY	TESTED WITH
1) SIO Port	2	2
2) PS/2 one to two adaptor	1	1
3) VGA Port	1	1
4) USB Port	2	2
5) LAN Port	1	1

I/O PORT (Model: ONYX-1922DT)

I/O PORT TYPES	Q'TY	TESTED WITH
6) SIO Port	2	2
7) PS/2 one to two adaptor	1	1
8) VGA Port	1	1
9) USB Port	2	2
10) LAN Port	1	1

Note: None.

3 TEST METHODOLOGY

3.1. DECISION OF FINAL TEST MODE

The EUT was tested together with the above additional components, and a configuration, which produced the worst emission levels, was selected and recorded in this report.

The test configuration/ modes is as the following:

Conduction Modes:

1	ONYX-1722DT	EUT + D-SUB MODE / 1280X1024, VF=70Hz
2		EUT + D-SUB MODE / 1024X768, VF=70Hz
3		EUT + D-SUB MODE / 800X600, VF=75Hz
4		D-SUB MODE / 2048X1536, VF=60Hz
5	ONYX-1922DT	EUT + D-SUB MODE / 1280X1024, VF=70Hz
6		EUT + D-SUB MODE / 1024X768, VF=70Hz
7		EUT + D-SUB MODE / 800X600, VF=75Hz

Radiation Modes:

1	ONYX-1722DT	EUT + D-SUB MODE / 1280X1024, VF=70Hz
2		EUT + D-SUB MODE / 1024X768, VF=70Hz
3		EUT + D-SUB MODE / 800X600, VF=75Hz
4		D-SUB MODE / 2048X1536, VF=60Hz
5	ONYX-1922DT	EUT + D-SUB MODE / 1280X1024, VF=70Hz
6		EUT + D-SUB MODE / 1280X1024, VF=70Hz / 1-5.3GHz
6		EUT + D-SUB MODE / 1024X768, VF=70Hz
7		EUT + D-SUB MODE / 800X600, VF=75Hz

Conduction: Mode 7

Radiation: Mode 5



3.2. EUT SYSTEM OPERATION

1. Windows XP boots system.
2. Run Emctest.exe to activate all peripherals and display “H” pattern on monitor screen.
3. Run Winemc.exe and choose media player to play music.
4. Run Winemc.exe and choose “F:/ & G:/” to test EUT.
5. Press the start menu, select executive and type ping 192.168.0.1 -t (EUT), ping 192.168.0.2 -t (Server PC).

Note: Test program is self-repeating throughout the test.

4 SETUP OF EQUIPMENT UNDER TEST

4.1. DESCRIPTION OF SUPPORT UNITS

The EUT has been tested as an independent unit together with other necessary accessories or support units. The following support units or accessories were used to form a representative test configuration during the tests.

EUT Devices: (Model: ONYX-1722DT)

No.	Equipment	Model No.	Trade Name
1	CPU	Intel Core2 Duo U7500 1.06GHz	Intel
2	PANEL (TFT LCD 17")	CLAA170EA07 / 4 LAMP	CPT
3	Hard Disk	MHZ2080BH/80G	Fujitsu
4	Memory (1GB DDRII 667MHz)	ELPIDA E5108AG-6E-E	DSL

EUT Devices: (Model: ONYX-1922DT)

No.	Equipment	Model No.	Trade Name
1	CPU	Intel Core2 Duo U7500 1.06GHz	Intel
2	PANEL (TFT LCD 19")	HSD190MEN3-A00	HannStar
3	Hard Disk	MHZ2080BH/80G	Fujitsu
4	Memory (1GB DDRII 667MHz)	ELPIDA E5108AG-6E-E	DSL

Peripherals Devices:

No.	Equipment	Model No.	Serial No.	FCC ID / BSMI ID	Trade Name	Data Cable	Power Cord
1-2	USB 2.0 HDD X2	F12-U	N/A	BSMI ID: 4912A002	TeraSys	Shielded, 1.8m	N/A
3	PS/2 Mouse	M-S34	LZA81205785	BSMI ID: 4862A011	LOGITECH	Shielded, 1.8m	N/A
4	PS/2 Keyboard	Y-SP29	SYU25038731	BSMI ID: 3902C736	LOGITECH	Shielded, 1.8m	N/A
5	Monitor	2408WFP	N/A	N/A	DELL	Shielded, 1.8m with two cores	Unshielded, 1.8m
6-7	Modem X2	5JEG4033MKO	N/A	5RJTAI-35500-M5-E	TOP-SOLUTION	Shielded, 1.8m	Unshielded, 1.8m
8	Server PC	DCNE	GBPDH1S	BSMI: R33002	DELL	Unshielded, 20m	Unshielded, 1.8m

Note:

- 1) All the equipment/cables were placed in the worst-case configuration to maximize the emission during the test.
- 2) Grounding was established in accordance with the manufacturer’s requirements and conditions for the intended use.

4.2. CONFIGURATION OF SYSTEM UNDER TEST

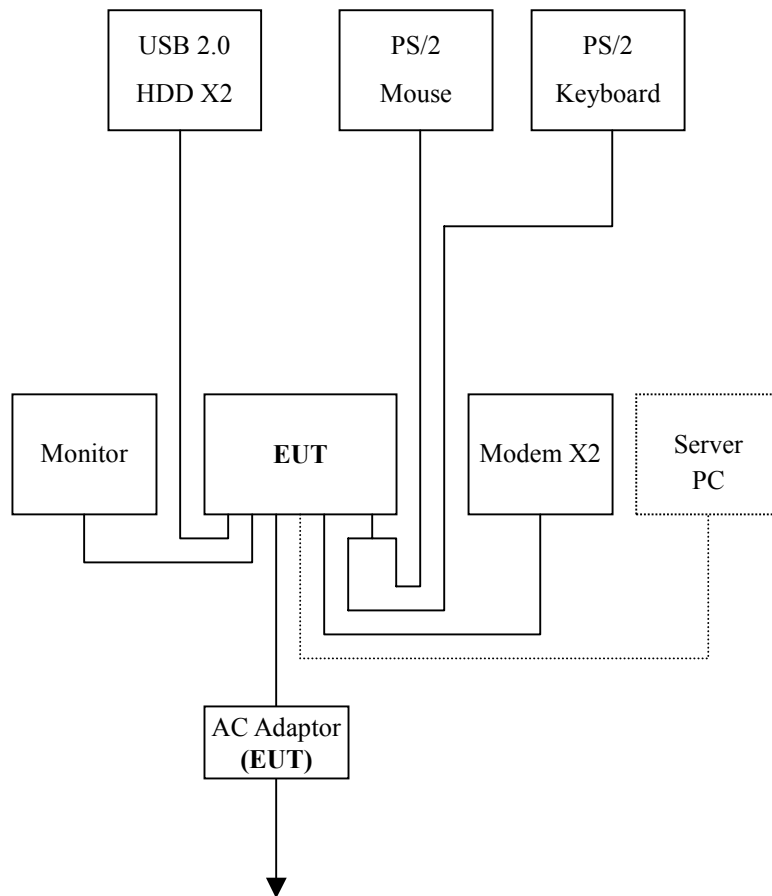

5 FACILITIES AND ACCREDITATIONS

5.1. FACILITIES

All measurement facilities used to collect the measurement data are located at CCS Taiwan Sindian BU. at No.163-1, Jhongsheng Rd., Sindian City, Taipei County 23151, Taiwan.

The sites are constructed in conformance with the requirements of ANSI C63.4 and CISPR Publication 22. All receiving equipment conforms to CISPR 16-1-1, CISPR 16-1-2, CISPR 16-1-3, CISPR 16-1-4 and CISPR 16-1-5.

5.2. ACCREDITATIONS

Our laboratories are accredited and approved by the following accreditation body according to ISO/IEC 17025.

Taiwan	TAF
USA	A2LA

The measuring facility of laboratories has been authorized or registered by the following approval agencies.

Canada	Industry Canada
Germany	TUV Rheinland
Japan	VCCI
Taiwan	BSMI
USA	FCC

Copies of granted accreditation certificates are available for downloading from our web site, <http://www.ccsemc.com>

5.3. MEASUREMENT UNCERTAINTY

Where relevant, the following measurement uncertainty levels have been estimated for tests performed on the EUT as specified in CISPR 16-4-2:

Measurement	Frequency	Uncertainty
Conducted emissions	0.15MHz~30MHz	± 1.7366
Radiated emissions	30MHz ~ 200MHz	± 3.9041
	200MHz ~1000MHz	± 3.9162

This uncertainty represents an expanded uncertainty expressed at approximately the 95% confidence level using a coverage factor of k=2.

Consistent with industry standard (e.g. CISPR 22: 2006, clause 11, Measurement Uncertainty) determining compliance with the limits shall be base on the results of the compliance measurement. Consequently the measure emissions being less than the maximum allowed emission result in this be a compliant test or passing test.

The acceptable measurement uncertainty value without requiring revision of the compliance statement is base on conducted and radiated emissions being less than U_{CISPR} which is 3.6dB and 5.2dB respectively. CCS values (called U_{Lab} in CISPR 16-4-2) is less than U_{CISPR} as shown in the table above. Therefore, MU need not be considered for compliance.



6 CONDUCTED EMISSION MEASUREMENT

6.1. LIMITS OF CONDUCTED EMISSION MEASUREMENT

Maximum permissible level of Line Conducted Emission

Frequency (MHZ)	(dBuV)	
	Quasi-peak	Average
0.15-0.5	66-56	56-46
0.50 - 5.0	56	46
5.0 - 30.0	60	50

NOTE:

- (1) The lower limit shall apply at the transition frequencies.
- (2) The limit decreases in line with the logarithm of the frequency in the range of 0.15 to 0.50 MHz.
- (3) All emanations from a class A/B digital device or system, including any network of conductors and apparatus connected thereto, shall not exceed the level of field strengths specified above.

6.2. TEST INSTRUMENTS

Conducted Emission Test Site # B				
Name of Equipment	Manufacturer	Model	Serial Number	Calibration Due
TEST RECEIVER	R&S	ESHS10	843743/015	03/29/2010
LISN (EUT)	FCC	FCC-LISN-50-32-2	08009	03/29/2010
LISN	EMCO	3825/2	1382	01/05/2010
BNC CABLE	Huber+Suhner	RG 223/U	BNC B2	01/12/2010
Pulse Limiter	R&S	ESH3-Z2	100374	08/22/2009
THERMO-HYGRO METER	TOP	HA-202	9303-3	02/04/2010
Test S/W	EMI 32.exe			

- NOTE:** 1. The calibration interval of the above test instruments is 12 months and the calibrations are traceable to NML/ROC and NIST/USA.
2. N.C.R = No Calibration Request.



6.3. TEST PROCEDURES (please refer to measurement standard or CCS SOP PA-031)

Procedure of Preliminary Test

- The EUT and Support equipment, if needed, was set up as per the test configuration to simulate typical usage per the user's manual. When the EUT is a tabletop system, a wooden table with a height of 0.8 meters is used and is placed on the ground plane as per ANSI C63.4 (see Test Facility for the dimensions of the ground plane used). When the EUT is a floor standing equipment, it is placed on the ground plane, which has a 12 mm non-conductive covering to insulate the EUT from the ground plane.
- All I/O cables were positioned to simulate typical actual usage as per ANSI C63.4.
- The test equipment EUT installed received AC main power, through a Line Impedance Stabilization Network (LISN), which supplied power source and was grounded to the ground plane.
- All support equipment power received from a second LISN.
- The EUT test program was started. Emissions were measured on each current carrying line of the EUT using an EMI Test Receiver connected to the LISN powering the EUT.
- The Receiver scanned from 150kHz to 30MHz for emissions in each of the test modes.
- During the above scans, the emissions were maximized by cable manipulation.
- The test mode(s) described in Item 3.1 were scanned during the preliminary test.
- After the preliminary scan, we found the test mode described in Item 3.1 producing the highest emission level.
- The EUT configuration and cable configuration of the above highest emission levels were recorded for reference of the final test.

Procedure of Final Test

- EUT and support equipment were set up on the test bench as per the configuration with highest emission level in the preliminary test.
- A scan was taken on both power lines, Line 1 and Line 2, recording at least the six highest emissions. Emission frequency and amplitude were recorded into a computer in which correction factors were used to calculate the emission level and compare reading to the applicable limit.
- The test data of the worst-case condition(s) was recorded.

6.4. TEST SETUP

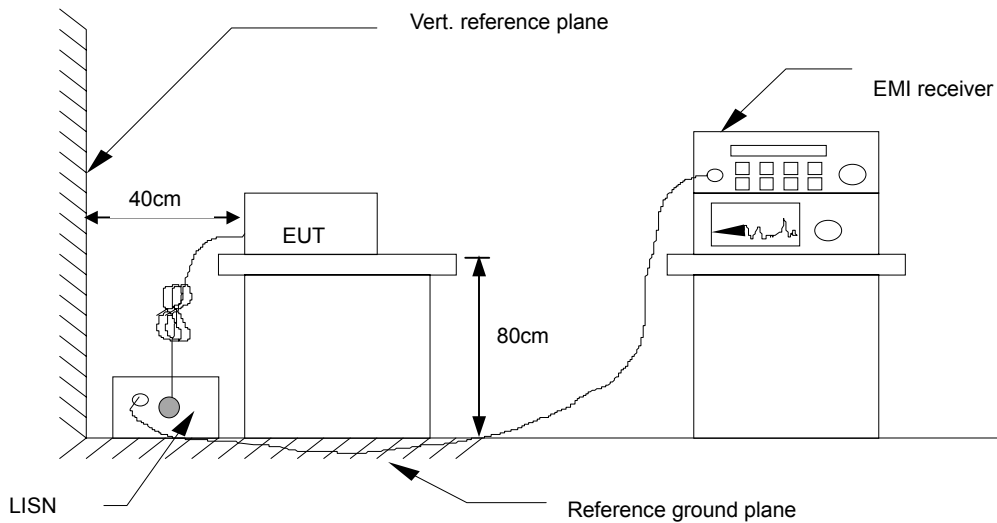

- For the actual test configuration, please refer to the related item – Photographs of the Test Configuration.

6.5. DATA SAMPLE

Freq. MHz	Read Level dBuV	Factor dB	Level dBuV	Limit dBuV	Over Limit dB	Remark (P/Q/A)	Line (L1/L2)
x.xx	42.95	0.55	43.50	56	-12.50	Q	L1

- Freq. = Emission frequency in MHz
- Read Level = Uncorrected Analyzer/Receiver reading
- Factor = Insertion loss of LISN + Cable Loss
- Level = Read Level + Factor
- Limit = Limit stated in standard
- Over Limit = Reading in reference to limit
- P = Peak Reading
- Q = Quasi-peak Reading
- A = Average Reading
- L1 = Hot side
- L2 = Neutral side

Calculation Formula

Over Limit (dB) = Level (dBuV) – Limit (dBuV)



6.6. TEST RESULTS

Model No.	ONYX-1922DT	6dB Bandwidth	10 KHz
Environmental Conditions	26deg.C, 50% RH, 1010hPa	Test Mode	Mode 7
Tested by	DAVID CHENG		

(The chart below shows the highest readings taken from the final data.)

Six Highest Conducted Emission Readings							
Frequency Range Investigated				150 KHz to 30 MHz			
Freq. (MHz)	Read Level (dBuV)	Factor (dB)	Level (dBuV)	Limit Line (dBuV)	Over Limit (dB)	Remark (P/Q/A)	Line (L1/L2)
0.389	33.54	10.58	44.12	58.08	-13.96	P	L1
0.535	32.05	10.54	42.59	56.00	-13.41	P	L1
1.000	29.30	10.49	39.79	56.00	-16.21	P	L1
0.413	33.10	10.25	43.35	57.59	-14.25	P	L2
0.552	30.97	10.23	41.20	56.00	-14.80	P	L2
0.958	29.17	10.19	39.36	56.00	-16.64	P	L2

- NOTE:** 1. 0.15MHz to 30MHz test is Applicable Part 15.107 standard.
2. The emission level was or more than 2dB below the Average limit, so no re-check anymore.



7 RADIATED EMISSION MEASUREMENT

7.1. LIMITS OF RADIATED EMISSION MEASUREMENT

Maximum permissible level of Radiated Emission measured at 3meter

Frequency (MHZ)	Maximum Field Strength Limit (dBu V/m/ Q.P.)
30-88	40
88-216	43.5
216-960	46
Above 960	54

Note: The lower limit shall apply at the transition frequency.

Frequency (MHz)	dBuV/m (At 3m)	
	Average	Peak
Above 960	54	74

NOTE: (1) The lower limit shall apply at the transition frequencies.
(2) Emission level (dBuV/m) = 20 log Emission level (uV/m).

7.2. TEST INSTRUMENTS

Open Area Test Site # I				
Name of Equipment	Manufacturer	Model	Serial Number	Calibration Due
MEASURE RECEIVER	SCHAFFNER	SCR3501	338	07/07/2009
SPECTRUM ANALYZER	ADVANTEST	R3132	120900008	No Calibration Required
ANTENNA	SCHAFFNER	CBL 6112B	2809	09/08/2009
AMPLIFIER	SCHAFFNER	CPA9231A	3626	10/12/2009
CABLE	BELDEN	9913	N-TYPE #12	02/22/2010
THERMO-HYGRO METER	TECPEL	DTM-303	090639	05/24/2010
Test S/W	Lab VIEW 7.1			
Above 1GHz Used				
SPECTRUM ANALYZER (9kHz-30GHz)	R&S	FSP 30	100112	10/16/2009
ANTENNA (1-18GHz)	EMCO	3115	00022256	01/22/2010
AMPLIFIER (1-18GHz)	HP	8449B	3008A01266	01/19/2010
CABLE (1-18GHz)	JYEBAO	LL142	SMA#RS1	01/19/2010
CABLE (1-18GHz)	HUBER +SUHNER	SUCOFLEX 104	SMA#RS3	01/19/2010
CABLE (1-18GHz)	JYEBAO	LL142	SMA#C1	01/19/2010
Test S/W	EZ-EMC			

NOTE: 1. The calibration interval of the above test instruments is 12 months and the calibrations are traceable to NML/ROC and NIST/USA.
2. N.C.R = No Calibration Request.



7.3. TEST PROCEDURES (please refer to measurement standard or CCS SOP PA-031)

Procedure of Preliminary Test

- The equipment was set up as per the test configuration to simulate typical usage per the user's manual. When the EUT is a tabletop system, a wooden turntable with a height of 0.8 meters is used which is placed on the ground plane. When the EUT is a floor standing equipment, it is placed on the ground plane which has a 12 mm non-conductive covering to insulate the EUT from the ground plane.
- Support equipment, if needed, was placed as per ANSI C63.4.
- All I/O cables were positioned to simulate typical usage as per ANSI C63.4.
- The EUT received AC power source from the outlet socket under the turntable. All support equipment power received from another socket under the turntable.
- The antenna was placed at 10/3 meter away from the EUT as stated in ANSI C63.4. The antenna connected to the Spectrum Analyzer via a cable and at times a pre-amplifier would be used.
- The Analyzer / Receiver quickly scanned from 30MHz to 5300MHz. The EUT test program was started. Emissions were scanned and measured rotating the EUT to 360 degrees and positioning the antenna 1 to 4 meters above the ground plane, in both the vertical and the horizontal polarization, to maximize the emission reading level.
- The test mode(s) described in Item 3.1 were scanned during the preliminary test:
- After the preliminary scan, we found the test mode described in Item 3.1 producing the highest emission level.
- The EUT and cable configuration, antenna position, polarization and turntable position of the above highest emission level were recorded for the final test.

Procedure of Final Test

- EUT and support equipment were set up on the turntable as per the configuration with highest emission level in the preliminary test.
- The Analyzer / Receiver scanned from 30MHz to 5300MHz. Emissions were scanned and measured rotating the EUT to 360 degrees, varying cable placement and positioning the antenna 1 to 4 meters above the ground plane, in both the vertical and the horizontal polarization, to maximize the emission reading level.
- Recorded at least the six highest emissions. Emission frequency, amplitude, antenna position, polarization and turntable position were recorded into a computer in which correction factors were used to calculate the emission level and compare reading to the applicable limit and only Q.P. reading is presented.
- The test data of the worst-case condition(s) was recorded.

7.4. TEST SETUP

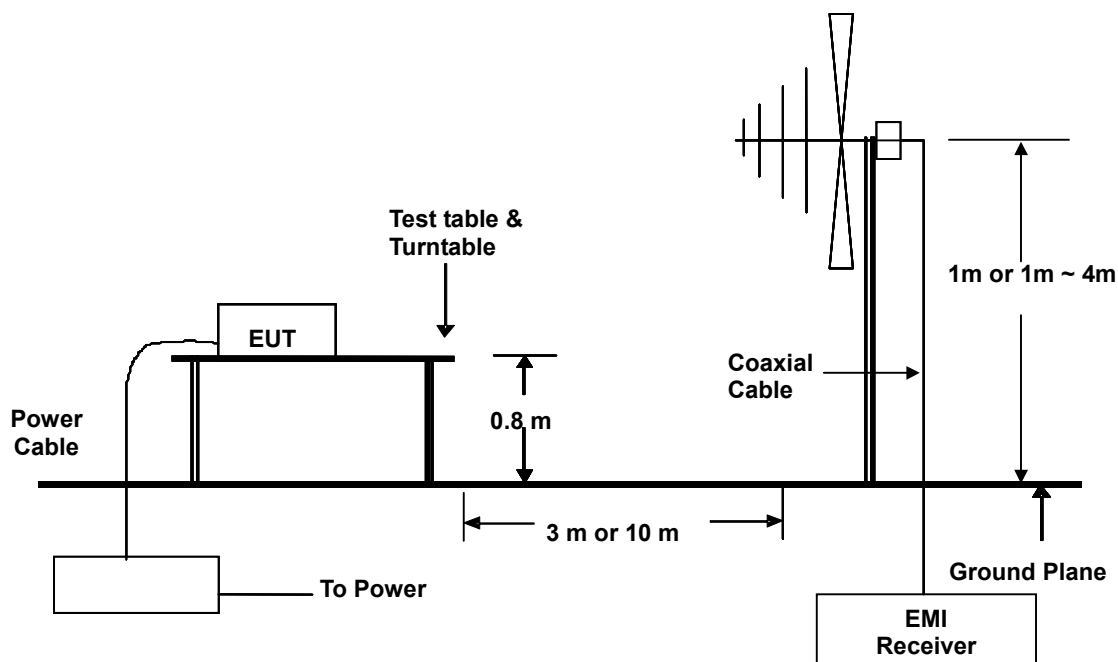

- For the actual test configuration, please refer to the related item – Photographs of the Test Configuration.



7.5. DATA SAMPLE

Below 1GHz

Freq. (MHz)	Reading (dBuV/m)	Factor (dB)	Result (dBuV/m)	Limit (dBuV/m)	Margin (dB)	Detector (P/Q)	Pol. (H/V)
x.xx	14.0	12.2	26.2	40	-13.8	Q	H

- Freq. = Emission frequency in MHz
- Reading = Uncorrected Analyzer/Receiver reading
- Factor = Antenna Factor + Cable Loss + Attenuator (3/6/10dB) – Amplifier Gain
- Amptd = Uncorrected Analyzer/Receiver reading + Factor
- Limit = Limit stated in standard
- Margin = Reading in reference to limit
- P = Peak Reading
- Q = Quasi-peak Reading
- H = Antenna Polarization: Horizontal
- V = Antenna Polarization: Vertical

Calculation Formula

Margin (dB) = Result (dBuV/m) – Limit (dBuV/m)

Above 1GHz

Freq. (MHz)	Reading (dBuV/m)	Factor (dB)	Result (dBuV/m)	Limit (dBuV/m)	Margin (dB)	Detector (P/A)	Pol. (H/V)
x.xx	42.95	0.55	43.50	54	-10.50	A	H

- Freq. = Emission frequency in MHz
- Reading = Uncorrected Analyzer/Receiver reading
- Factor = Antenna Factor + Cable Loss - Amplifier Gain
- Result = Reading + Factor
- Limit = Limit stated in standard
- Margin = Result – Limit
- P = Peak Reading
- A = Average Reading
- H = Antenna Polarization: Horizontal
- V = Antenna Polarization: Vertical



7.6. TEST RESULTS

Below 1GHz

Model No.	ONYX-1922DT	Test Mode	Mode 5
Environmental Conditions	28deg.C, 64% RH, 1010hPa	6dB Bandwidth	120 KHz
Antenna Pole	Vertical / Horizontal	Antenna Distance	3 m
Detector Function	Quasi-peak.	Tested by	WEBBER CHUNG

(The chart below shows the highest readings taken from the final data.)

Six Highest Radiated Emission Readings							
Frequency Range Investigated				30 MHz to 1000 MHz at 3m			
Freq. (MHz)	Reading (dBuV/m)	Factor (dB)	Result (dBuV/m)	Limit (dBuV/m)	Margin (dB)	Detector (P/Q)	Pol. (H/V)
37.390	51.00	-14.15	36.85	40.00	-3.15	Q	V
57.270	52.80	-21.03	31.77	40.00	-8.23	Q	V
109.130	51.30	-16.35	34.95	43.50	-8.55	Q	V
250.000	54.60	-13.97	40.63	46.00	-5.37	Q	V
480.060	45.80	-7.89	37.92	46.00	-8.09	Q	V
853.400	40.00	-2.03	37.97	46.00	-8.03	Q	V

Six Highest Radiated Emission Readings							
Frequency Range Investigated				30 MHz to 1000 MHz at 3m			
Freq. (MHz)	Reading (dBuV/m)	Factor (dB)	Result (dBuV/m)	Limit (dBuV/m)	Margin (dB)	Detector (P/Q)	Pol. (H/V)
37.360	46.60	-14.14	32.46	40.00	-7.54	Q	H
480.000	47.60	-7.89	39.71	46.00	-6.29	Q	H
500.030	48.40	-7.43	40.97	46.00	-5.03	Q	H
528.010	44.50	-6.59	37.91	46.00	-8.09	Q	H
540.040	43.00	-6.23	36.77	46.00	-9.23	Q	H
800.030	39.50	-2.87	36.63	46.00	-9.37	Q	H

- REMARKS:**
1. 30MHz to 1000MHz test is Applicable Part 15.109 standard.
 2. The other emission levels were very low against the limit.
 3. P= Peak Reading; Q= Quasi-peak Reading.



Above 1GHz

Model No.	ONYX-1922DT	Test Mode	Mode 5
Environmental Conditions	26deg.C, 60% RH, 1010hPa	6dB Bandwidth	1000 KHz
Antenna Pole	Vertical / Horizontal	Antenna Distance	3m
Detector Function	Peak or Average.	Tested by	DAVID CHENG

(The chart below shows the highest readings taken from the final data.)

Six Highest Radiated Emission Readings							
Frequency Range Investigated				30 MHz to 5300 MHz at 3m			
Freq. (MHz)	Reading (dBuV)	Factor (dB)	Result (dBuV/m)	Limit (dBuV/m)	Margin (dB)	Remark (P/A)	Pol. (H/V)
1068.000	59.72	-11.16	48.56	74.00	-25.44	P	V
1374.000	61.55	-9.63	51.92	74.00	-22.08	P	V
1578.000	50.08	-8.52	41.56	74.00	-32.44	P	V
2156.000	46.05	-5.40	40.65	74.00	-33.35	P	V
2598.000	45.53	-3.89	41.64	74.00	-32.36	P	V
3006.000	46.06	-2.18	43.88	74.00	-30.12	P	V

Six Highest Radiated Emission Readings							
Frequency Range Investigated				30 MHz to 5300 MHz at 3m			
Freq. (MHz)	Reading (dBuV)	Factor (dB)	Result (dBuV/m)	Limit (dBuV/m)	Margin (dB)	Remark (P/A)	Pol. (H/V)
1170.000	47.14	0.00	47.14	74.00	-26.86	P	H
1374.000	51.29	0.00	51.29	74.00	-22.71	P	H
2700.000	42.49	-3.46	39.03	74.00	-34.97	P	H
3448.000	44.17	-0.95	43.22	74.00	-30.78	P	H
4298.000	43.35	0.96	44.31	74.00	-29.69	P	H
4876.000	42.14	2.28	44.42	74.00	-29.58	P	H

NOTE: 1. The other emission levels were very low against the limit.
 2. P= Peak Reading; A= Average Reading.

8 PHOTOGRAPHS OF THE TEST CONFIGURATION

LINE CONDUCTED EMISSION TEST



RADIATED EMISSION TEST

