



FCC EMC Test Report

according to

47 CFR FCC Rules and Regulations Part 15 Subpart B, Class A Digital Device

Equipment : SubCompact Board
Model No. : xGENE-BT06x
(x - Where x may be any combination of alphanumeric characters or "-" or blank for marketing purpose)
Filing Type : Verification
Applicant : **AAEON Technology Inc.**
5F, No. 135, Lane 235, Pao Chiao Rd., Hsin - Tien Dist,
New Taipei City, 231 Taiwan, R.O.C.

- The test result refers exclusively to the test presented test model / sample.
- Without written approval of SPORTON International Inc., the test report shall not be reproduced except in full.

SPORTON International Inc.

No. 52, Hwa Ya 1st Rd., Hwa Ya Technology Park, Kwei-Shan District, Taoyuan City, Taiwan, R.O.C.



Table of Contents

VERIFICATION OF COMPLIANCE 1
1. General Description of Equipment under Test..... 2
1.1 Applicant 2
1.2 Manufacturer 2
1.3 Basic Description of Equipment under Test 2
1.4 Feature of Equipment under Test 2
1.5 Modification of EUT 2
2. Test Configuration of Equipment under Test 3
2.1 Test Manner 3
2.2 Description of Test System 4
2.3 Connection Diagram of Test System for Radiation Emission 6
3. Test Software 7
4. General Information of Test..... 8
4.1 Test Facility 8
4.2 Uncertainty of Test Site..... 8
4.3 Test Voltage 8
4.4 Standard for Methods of Measurement 8
4.5 Test in Compliance with 8
4.6 Frequency Range Investigated 8
5. Test of Conducted Powerline 9
5.1 Test Procedures..... 9
5.2 Typical Test Setup Layout of Conducted Powerline 9
5.3 Test Result of AC Powerline Conducted Emission 10
6. Test of Radiated Emission..... 12
6.1 Test Procedures..... 12
6.2 Test Result of Radiated Emission (Below 1GHz) 13
6.3 Test Result of Radiated Emission (Above 1GHz) 21
7. List of Measuring Equipment Used 25
8. Notice for Class A Product 27
Appendix A. TEST PHOTOS
Appendix B. Photographs of EUT



History of this test report

Report No.	Version	Description	Issued Date
FV562609	Rev. 01	Initial issue of report	Jul. 13, 2015



VERIFICATION OF COMPLIANCE

according to

47 CFR FCC Rules and Regulations Part 15 Subpart B, Class A Digital Device

Equipment : SubCompact Board
Model No. : xGENE-BT06x
(x - Where x may be any combination of alphanumeric characters or "-" or blank for marketing purpose)
Applicant : **AAEON Technology Inc.**
5F, No. 135, Lane 235, Pao Chiao Rd., Hsin - Tien Dist,
New Taipei City, 231 Taiwan, R.O.C.

I **HEREBY** CERTIFY THAT :

The measurements shown in this test report were made in accordance with the procedures given in **ANSI C63.4 - 2009** and the energy emitted by this equipment were **passed CISPR PUB. 22 and FCC Part 15 Subpart B** in both radiated and conducted emission **Class A** limits.

The product sample received on Jun. 25, 2015 and completely tested on Jul. 04, 2015 at **SPORTON International Inc. LAB**

Kero Kuo / Assistant Manager

SPORTON International Inc.

No. 52, Hwa Ya 1st Rd., Hwa Ya Technology Park, Kwei-Shan District, Taoyuan City, Taiwan, R.O.C.



1. General Description of Equipment under Test

1.1 Applicant

AAEON Technology Inc.
5F, No. 135, Lane 235, Pao Chiao Rd., Hsin - Tien Dist,
New Taipei City, 231 Taiwan, R.O.C.

1.2 Manufacturer

Same as 1.1

1.3 Basic Description of Equipment under Test

Equipment : SubCompact Board
Model No. : xGENE-BT06x
(x - Where x may be any combination of alphanumeric characters or "-" or blank for marketing purpose)
Trade Name : AAEON
Y Cable : AL-F-Shielded, 0.2 m
RS232 Cable : Non-Shielded, 1.6 m
Data Cable Type : Please see section 2.2 of this test report for details
Power Supply Type : From Switching Power Supply
AC Power Cord : Non-Shielded, 1.8 m, 3 pin

The maximum operating frequency : 1.91 GHz

1.4 Feature of Equipment under Test

Please refer to user manual.

1.5 Modification of EUT

None.



2. Test Configuration of Equipment under Test

2.1 Test Manner

- a. The EUT has been associated with supporting units and peripherals pursuant to ANSI C63.4-2009 and configuration operated in a manner which tended to maximize its emission characteristics in a typical application.
- b. The equipment under test were performed the following test modes:

Test Items	Description of test modes
AC Conducted Emission	Mode 1. R/W, D-SUB+HDMI:1920*1200 60Hz, LAN 1Gbps*2
Radiated Emissions	Mode 1. R/W, D-SUB+HDMI:1920*1200 60Hz, LAN 1Gbps*2 Mode 2. R/W, D-SUB+HDMI:1920*1200 60Hz, LAN 1Gbps*2, Open Case

- c. Frequency range investigated: Conducted 150 kHz to 30 MHz, Radiated 30 MHz to 10,000 MHz.



2.2 Description of Test System

< For conducted emission and radiated emission below 1GHz >

No.	Peripheral	Manufacturer	Model Number	FCC ID	Cable / Spec. Description
For Local					
1	LCD Monitor	DELL	2408WFPB	DoC	D-SUB Cable, D-Shielded, 1.8m
2	LCD Monitor	DELL	2408WFPB	DoC	HDMI Cable, D-Shielded, 1.5m
3	Keyboard	HP	KB-0133	DoC	PS2 Cable, AL-F-Shielded, 1.85m
4	Mouse	HP	M-S69	JNZ211443	PS2 Cable, AL-F-Shielded, 1.8m
5	Printer	XEROX	PHASER3121	DoC	USB Cable, D-Shielded, 1.8m
6	Modem*4	ACEEX	DM1414	IFAXDM1414	RS-232 Cable, D-Shielded, 1.15m
7	Headset	i-Acon	HOH-323-BK	-	Audio Cable, Non-Shielded, 2.0m
8	USB 3.0 Flash Disk*3	PQI	U273V	DoC	-
9	CPU	INTEL	E3845	-	-
10	HDD	TOSHIBA	160G	-	-
11	Power	FSP	FSP300-701UJ 300W	-	-
For Remote					
-	Personal Computer*2	Lenovo	C61	DoC	RJ45 Cable, Non-Shielded, 20.0m
-	LCD Monitor*2	DELL	E198WFPF	DoC	D-SUB Cable, D-Shielded, 1.8m
-	Keyboard*2	Lenovo	KU-0225	DoC	USB Cable, AL-F-Shielded, 1.8m
-	Mouse*2	Lenovo	M-U0025-O	DoC	USB Cable, AL-F-Shielded, 1.8m



< For radiated emission above 1GHz >

No.	Peripheral	Manufacturer	Model Number	FCC ID	Cable / Spec. Description
For Local					
1	LCD Monitor	DELL	2408WFPB	DoC	D-SUB Cable, D-Shielded, 1.8m
2	LCD Monitor	DELL	U2410f	DoC	HDMI Cable, D-Shielded, 1.5m
3	Keyboard	HP	KB-0133	DoC	PS2 Cable, AL-F-Shielded, 1.85m
4	Mouse	HP	M-S69	JNZ211443	PS2 Cable, AL-F-Shielded, 1.8m
5	Printer	EPSON	C61	-	USB Cable, D-Shielded, 1.8m
6	Modem*4	ACEEX	DM1414	IFAXDM1414	RS-232 Cable, D-Shielded, 1.15m
7	USB 3.0 Flash Disk*3	PQI	U821V	DoC	-
8	Headset	INTOPIC	JAZZ-368	-	Audio Cable, Non-Shielded, 2.0m
9	CPU	INTEL	E3845	-	-
10	HDD	TOSHIBA	160G	-	-
11	Power	FSP	FSP300-701UJ 300W	-	-
For Remote					
-	Personal Computer*2	HP	DC7700	DoC	RJ45 Cable, Non-Shielded, 10.0m
-	LCD Monitor*2	DELL	2408WFPB	DoC	D-SUB Cable, D-Shielded, 1.8m
-	Keyboard*2	Microsoft	1366	DoC	USB Cable, AL-F-Shielded, 1.8m
-	Mouse*2	Microsoft	1113	DoC	USB Cable, AL-F-Shielded, 1.8m

2.3 Connection Diagram of Test System for Radiation Emission

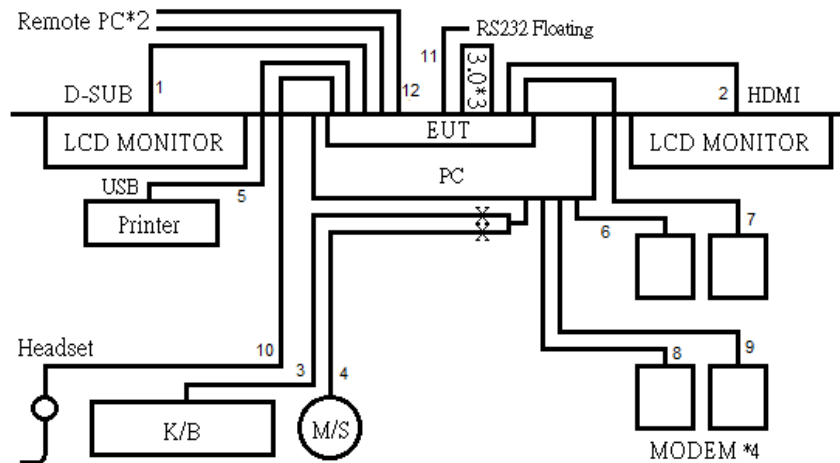

1. The D-SUB cable is connected from EUT to the support unit 1.
2. The HDMI cable is connected from EUT to the support unit 2.
3. The PS/2 cable is connected from PC to the support unit 3.
4. The PS/2 cable is connected from PC to the support unit 4.
5. The USB cable is connected from PC to the support unit 5.
6. The RS-232 cable is connected from PC to the support unit 6.
7. The RS-232 cable is connected from EUT to the support unit 6.
8. The RS-232 cable is connected from PC to the support unit 6.
9. The RS-232 cable is connected from PC to the support unit 6.
10. The Audio cable is connected from EUT to the support unit 7.
11. The RS232 cable is floating.
12. This RJ45 cables are connected from EUT to the remote workstation.



3. Test Software

An executive program, "EMIprogram.exe" under WIN 7, which generates a complete line of continuously repeating "H" pattern was used as the test software.

The program was executed as follows:

- a. Turn on the power of all equipment.
- b. The PC reads the test program from the hard disk drive and runs it.
- c. The PC sends "H" messages to the printer, and then the printer prints them on the paper.
- d. The PC sends signal messages to the modem.
- e. The PC sends signal messages to the internal Hard Disk, and the Hard Disk reads and writes the message.
- f. Repeat the steps from c to e.

At the same time, the following were executed:

- Executed "BurnInTest.exe" to display continuously repeating "H" patterns.
- Executed "EMIprogram.exe" to read and write data from USB 3.0 flash disk..
- Executed "BurnInTest.exe" to play audio via headset.
- Executed "Sound Recorder.exe" to record the audio signal via microphone.
- Executed "PING.exe" to link with the remote workstation to maintain the connection via RJ45 cable.

4. General Information of Test

4.1 Test Facility

Test Site Location : No. 3, Lane 238, Kang Lo Street, Nei Hwu District, Taipei 11424, Taiwan, R.O.C.
TEL : 886-2-2631-4739
FAX : 886-2-2631-9740

Test Site No. : CO01-NH, OS02-NH

Test Site Location : No. 52, Hwa Ya 1st Rd., Hwa Ya Technology Park, Kwei-Shan District, Tao Yuan City, Taiwan, R.O.C.
TEL : 886-3-327-3456
FAX : 886-3-318-0055

Test Site No. : 03CH04-HY

4.2 Uncertainty of Test Site

Test Items	Test Site No.	Uncertainty	Remark
Conducted Emissions	CO01-NH	± 2.6dB	Confidence levels of 95%
Radiated Emissions below 1GHz	OS02-NH	± 3.0dB	Confidence levels of 95%
Radiated Emissions above 1GHz	03CH04-HY	± 4.7dB	Confidence levels of 95%

4.3 Test Voltage

120VAC / 60Hz

4.4 Standard for Methods of Measurement

ANSI C63.4-2009

4.5 Test in Compliance with

CISPR PUB. 22 and FCC Rules and Regulations Part 15 Subpart B

4.6 Frequency Range Investigated

- a. Conducted emission test: from 150 kHz to 30 MHz
- b. Radiated emission test: from 30 MHz to 11,000 MHz
 - The test distance of radiated emission from antenna to EUT is 10 M (from 30MHz ~ 1GHz)
 - The test distance of radiated emission from antenna to EUT is 3 M (from 1GHz ~ 10GHz)

5. Test of Conducted Powerline

Conducted Emissions were measured from 150 kHz to 30 MHz with a bandwidth of 9 kHz and return leads of the EUT according to the methods defined in ANSI C63.4-2009 Section 3.1. The EUT was placed on a nonmetallic stand in a shielded room 0.8 meter above the ground plane. The interface cables and equipment positioning were varied within limits of reasonable applications to determine the position produced maximum conducted emissions.

5.1 Test Procedures

- a. The EUT was warmed up for 15 minutes before testing started.
- b. The EUT was placed on a desk 0.8 meters height from the metal ground plane and 0.4 meter from the conducting wall of the shielding room and it was kept at least 0.8 meters from any other grounded conducting surface.
- c. Connect EUT to the power mains through a line impedance stabilization network (LISN).
- d. All the support units are connected to the other LISN.
- e. The LISN provides 50 ohm coupling impedance for the measuring instrument.
- f. The CISPR states that a 50 ohm, 50 micro henry LISN should be used.
- g. Both sides of AC line were checked for maximum conducted interference.
- h. The frequency range from 150 kHz to 30 MHz was searched.
- i. Set the test-receiver system to Peak Detect Function and Specified Bandwidth with Maximum Hold Mode.

5.2 Typical Test Setup Layout of Conducted Powerline

- a. AMN is 80 cm from the EUT and at least 80 cm from other units and other metal planes.
- b. EUT is connected to one artificial mains network (AMN).
- c. All other units of a system are powered from a second AMN. A multiple outlet strip can be used for multiple mains cords.
- d. Rear of EUT to be flushed with rear of table top.
- e. Peripherals shall be placed at a distance of 10 cm from each other and from the controller, except for the monitor which, if this is an acceptable installation practice, shall be placed directly on the top of the controller.
- f. If cables, which hang closer than 40 cm to the horizontal metal ground plane, cannot be shortened to appropriate length, the excess shall be folded back and forth forming a bundle 30 cm to 40 cm long.
- g. Mains cords and signal cables shall be positioned for their entire lengths, as far as possible, at 40 cm from the vertical reference plane.
- h. Cables of hand operated devices, such as keyboards, mice, etc. shall be placed as for normal usage.

5.3 Test Result of AC Powerline Conducted Emission

Test Mode	Mode 1	Test Site No.	CO01-NH
Test Frequency	0.15 MHz ~ 30 MHz	Test Engineer	Willy
Temperature	26 °C	Relative Humidity	52 %
Note: 1. Corrected Reading (dB μ V) = LISN Factor + Cable Loss + Read Level = Level			
2. All emissions not reported here are more than 10 dB below the prescribed limit.			
■The test was passed at the minimum margin that marked by the frame in the following data			

Line

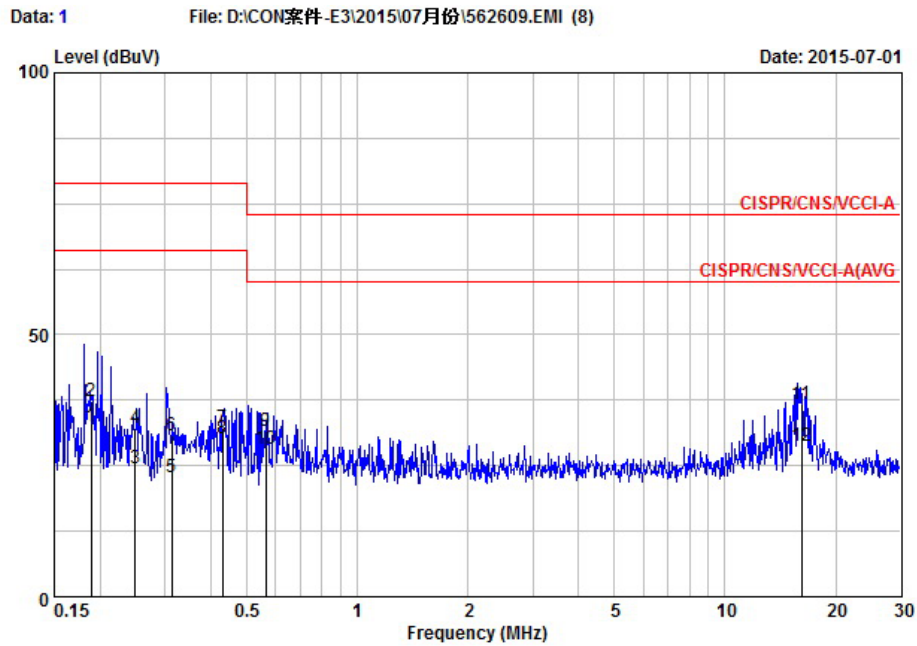

	Freq	Level	Over	Limit	Read	LISN	Cable	
	MHz	dBuV	Limit	Line	Level	Factor	Loss	Remark
			dB	dBuV	dBuV	dB	dB	
1 e	0.189	32.41	-33.59	66.00	21.84	10.47	0.10	AVERAGE
2	0.189	37.31	-41.69	79.00	26.74	10.47	0.10	QP
3	0.249	24.60	-41.40	66.00	14.03	10.47	0.10	AVERAGE
4	0.249	32.33	-46.67	79.00	21.76	10.47	0.10	QP
5	0.313	22.93	-43.07	66.00	12.35	10.48	0.10	AVERAGE
6	0.313	30.81	-48.19	79.00	20.23	10.48	0.10	QP
7	0.431	32.32	-46.68	79.00	21.73	10.48	0.11	QP
8 e	0.431	30.23	-35.77	66.00	19.64	10.48	0.11	AVERAGE
9	0.565	31.62	-41.38	73.00	21.00	10.48	0.14	QP
10 e	0.565	28.17	-31.83	60.00	17.55	10.48	0.14	AVERAGE
11 e	16.140	36.75	-36.25	73.00	25.68	10.75	0.33	QP
12 e	16.140	28.73	-31.27	60.00	17.66	10.75	0.33	AVERAGE

Neutral

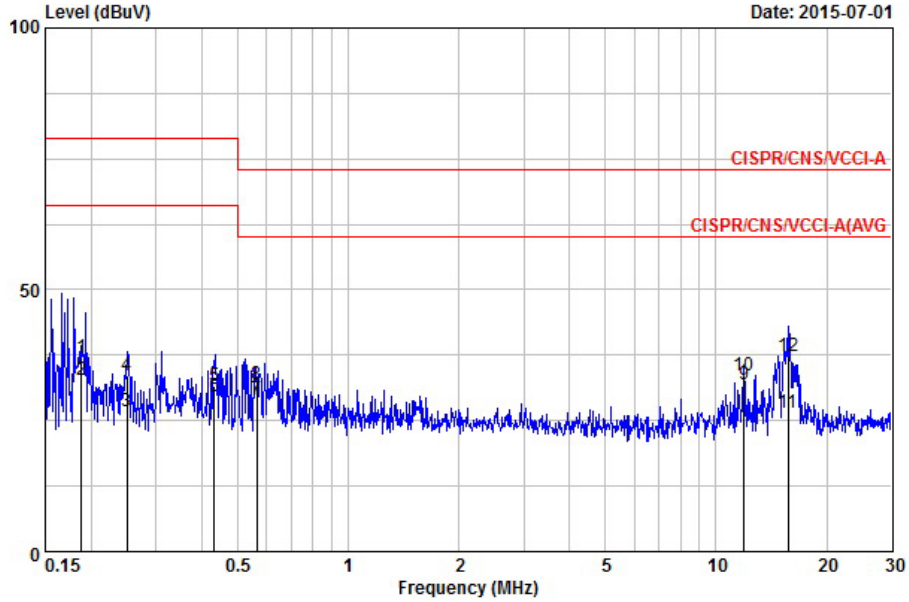

	Freq	Level	Over	Limit	Read	LISN	Cable	Remark
	MHz	dBuV	Limit	Line	Level	Factor	Loss	
			dB	dBuV	dBuV	dB	dB	
1	0.188	36.91	-42.09	79.00	26.68	10.13	0.10	QP
2 e	0.188	32.82	-33.18	66.00	22.59	10.13	0.10	AVERAGE
3	0.251	26.67	-39.33	66.00	16.44	10.13	0.10	AVERAGE
4	0.251	33.56	-45.44	79.00	23.33	10.13	0.10	QP
5	0.433	31.62	-47.38	79.00	21.39	10.12	0.11	QP
6 e	0.433	29.69	-36.31	66.00	19.46	10.12	0.11	AVERAGE
7 e	0.564	29.00	-31.00	60.00	18.74	10.12	0.14	AVERAGE
8	0.564	32.04	-40.96	73.00	21.78	10.12	0.14	QP
9 e	11.921	31.82	-28.18	60.00	21.19	10.34	0.30	AVERAGE
10	11.921	33.67	-39.33	73.00	23.04	10.34	0.30	QP
11 e	15.718	26.52	-33.48	60.00	15.78	10.42	0.32	AVERAGE
12 e	15.718	37.26	-35.74	73.00	26.52	10.42	0.32	QP

6. Test of Radiated Emission

Radiated emissions from 30 MHz to 10,000 MHz were measured with a bandwidth of 120 kHz for 30 MHz to 1000 MHz and 1 MHz for above 1GHz according to the methods defines in ANSI C63.4-2009. The EUT was placed on a nonmetallic stand, 0.8 meter above the ground plane. The interface cables and equipment positions were varied within limits of reasonable applications to determine the positions producing maximum radiated emissions.

6.1 Test Procedures

- a. The EUT was placed on a rotatable table top 0.8 meter above ground.
- b. The EUT was set at 3m(above 1GHz) and 10m(below 1GHz) from the interference-receiving antenna which was mounted on the top of a variable height antenna tower.
- c. The table was rotated 360 degrees to determine the position of the highest radiation.
- d. The antenna is a half wave dipole and its height is varied between one meter and four meters above ground to find the maximum value of the field strength both horizontal polarization and vertical polarization of the antenna are set to make the measurement.
- e. For each suspected emission the EUT was arranged to its worst case and then tune the antenna tower (from 1 M to 4 M) and turn table (from 0 degree to 360 degrees) to find the maximum reading.
- f. Set the test-receiver system to Peak Detect Function and specified bandwidth with Maximum Hold Mode.
- g. If the emission level of the EUT in peak mode was 3 dB lower than the limit specified, then testing will be stopped and peak values of EUT will be reported, otherwise, the emissions which do not have 3 dB margin will be repeated one by one using the quasi-peak method and reported.
- h. The FCC Part 15.109 (g) permit parties seeking to authorize a digital device to choose to demonstrate that the device complies with either the Part 15 standards or the international standards found in Publication 22 of the International Special Committee on Radio Interference (CISPR)
- i. For testing above 1GHz, the emission level of the EUT in peak mode was 20dB lower than average limit (that means the emission level in peak mode also complies with the limit in average mode), then testing will be stopped and peak values of EUT will be reported, otherwise, the emissions will be measured in average mode again and reported.
- j. The main board was tested in accordance with section 15.32 of the FCC rules. Testing for radiated emissions was first performed with the main board installed in a typical enclosure but with the enclosure's cover removed so that the internal circuitry is exposed at the top and on at least two sides. And then the EUT was tested with enclosure's cover unless it pass the required limits at first condition.



6.2 Test Result of Radiated Emission (Below 1GHz)

Test mode	Mode 1	Test Site No.	OS02-NH
Test frequency	30 MHz ~ 1000 MHz	Test Engineer	Chas
Temperature	26 °C	Relative Humidity	51 %
Note: 1. Emission level (dBμV/m) = 20 log Emission level (μV/m)			
2. Corrected Reading : Probe Factor + Cable Loss + Read Level – Preamp Factor = Level			
■The test was passed at the minimum margin that marked by the frame in the following data			

Vertical

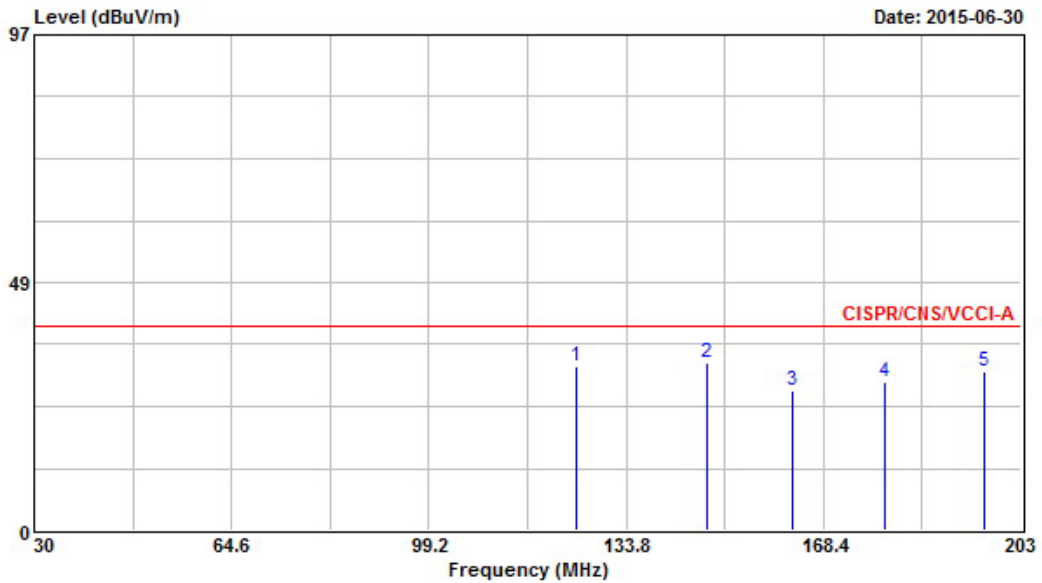

	Freq	Level	Over Limit	Limit Line	Read Level	Antenna Factor	Cable Loss	Preamp Factor	Remark	Ant Pos	Table Pos
	MHz	dBuV/m	dB	dBuV/m	dBuV	dB/m	dB	dB		cm	deg
1	125.150	31.96	-8.04	40.00	49.90	12.21	1.47	31.62	Peak	---	---
2	147.990	32.84	-7.16	40.00	52.12	10.67	1.62	31.57	Peak	100	180
3	163.040	27.16	-12.84	40.00	46.98	10.01	1.71	31.54	Peak	---	---
4	179.130	28.99	-11.01	40.00	49.25	9.45	1.79	31.50	Peak	---	---
5	196.430	31.25	-8.75	40.00	51.37	9.41	1.93	31.46	Peak	---	---



Vertical

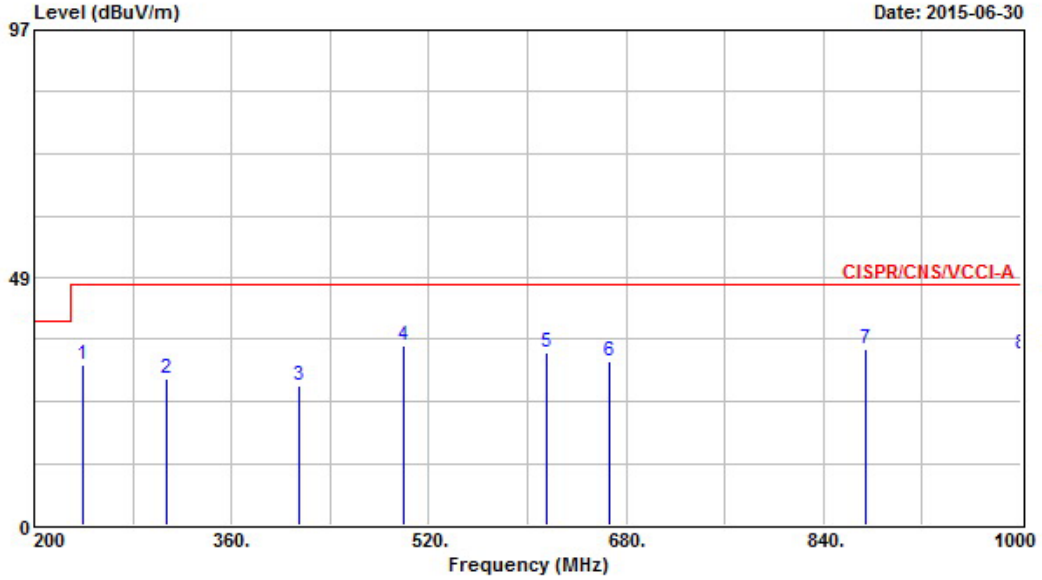

	Freq	Level	Over Limit	Limit Line	ReadAntenna Level	Antenna Factor	Cable Loss	Preamp Factor	Remark	Ant Pos	Table Pos
	MHz	dBuV/m	dB	dBuV/m	dBuV	dB/m	dB	dB		cm	deg
1	240.000	31.57	-15.43	47.00	49.05	11.81	2.13	31.42	Peak	---	---
2	307.200	28.67	-18.33	47.00	44.13	13.52	2.40	31.38	Peak	---	---
3	414.400	27.44	-19.56	47.00	39.92	16.02	2.87	31.37	Peak	---	---
4	499.200	35.11	-11.89	47.00	45.68	17.56	3.21	31.34	Peak	---	---
5	615.200	33.91	-13.09	47.00	42.68	18.92	3.65	31.34	Peak	---	---
6	666.400	32.24	-14.76	47.00	40.48	19.19	3.86	31.29	Peak	---	---
7	874.400	34.42	-12.58	47.00	40.11	21.06	4.54	31.29	Peak	---	---
8	1000.000	33.46	-13.54	47.00	37.54	22.13	4.89	31.10	Peak	---	---



Horizontal

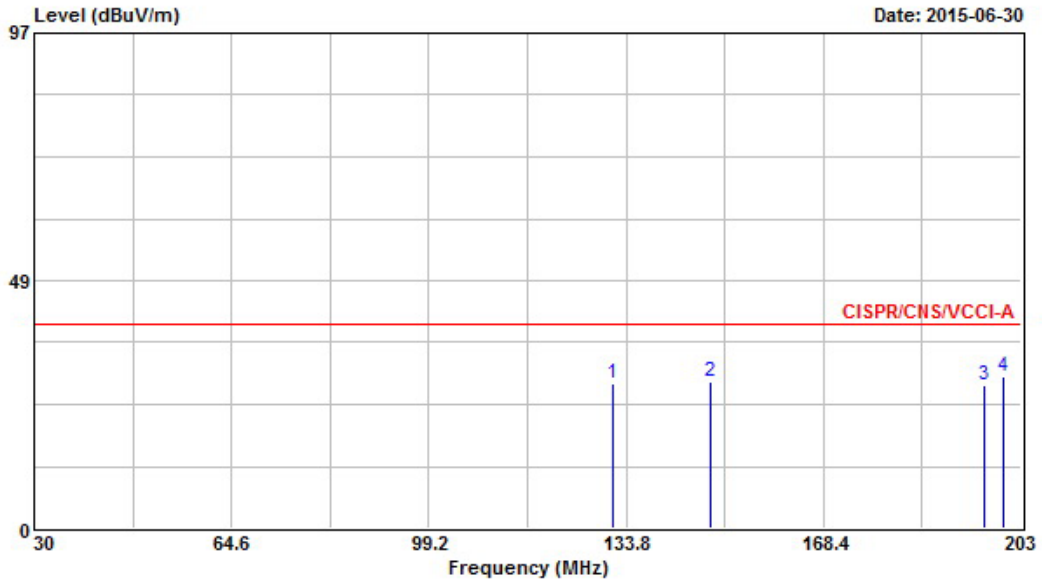

	Freq	Level	Over Limit	Limit Line	ReadAntenna Level	Antenna Factor	Cable Loss	Preamp Factor	Remark	Ant Pos	Table Pos
	MHz	dBuV/m	dB	dBuV/m	dBuV	dB/m	dB	dB		cm	deg
1	131.380	28.50	-11.50	40.00	46.81	11.78	1.52	31.61	Peak	---	---
2	148.510	28.54	-11.46	40.00	47.82	10.67	1.62	31.57	Peak	---	---
3	196.600	27.95	-12.05	40.00	48.07	9.41	1.93	31.46	Peak	---	---
4	200.060	29.75	-10.25	40.00	49.87	9.41	1.92	31.45	Peak	---	---



Horizontal

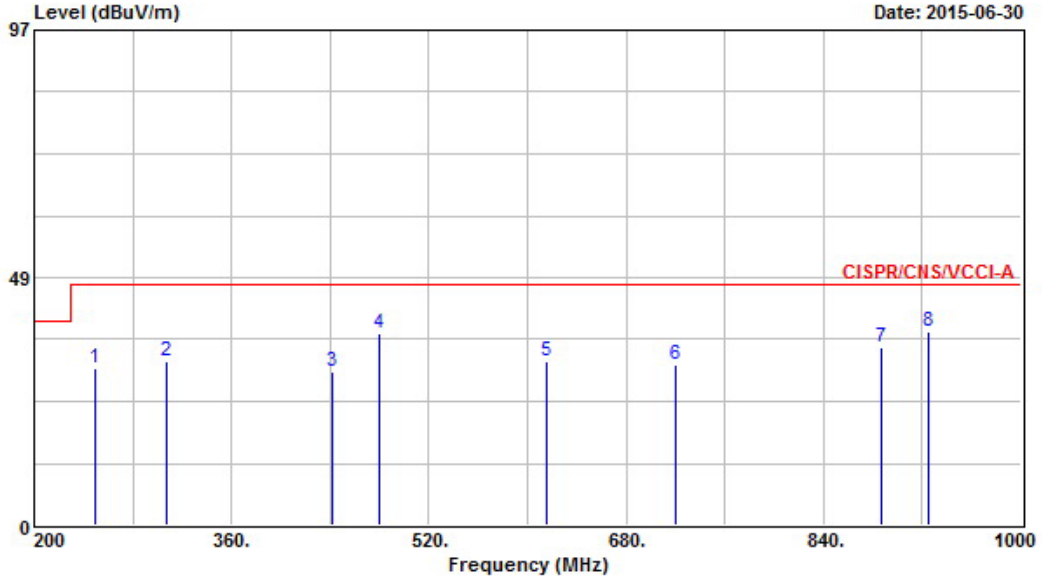

	Freq	Level	Over Limit	Limit Line	ReadAntenna Level	Antenna Factor	Cable Loss	Preamp Factor	Remark	Ant Pos	Table Pos
	MHz	dBuV/m	dB	dBuV/m	dBuV	dB/m	dB	dB		cm	deg
1	249.600	30.87	-16.13	47.00	47.73	12.39	2.17	31.42	Peak	---	---
2	307.200	31.95	-15.05	47.00	47.41	13.52	2.40	31.38	Peak	---	---
3	441.600	30.08	-16.92	47.00	41.95	16.51	2.98	31.36	Peak	---	---
4	480.000	37.47	-9.53	47.00	48.48	17.21	3.13	31.35	Peak	---	---
5	615.200	32.11	-14.89	47.00	40.88	18.92	3.65	31.34	Peak	---	---
6	720.000	31.37	-15.63	47.00	39.00	19.59	4.04	31.26	Peak	---	---
7	886.400	34.73	-12.27	47.00	40.28	21.14	4.59	31.28	Peak	---	---
8	924.800	37.95	-9.05	47.00	43.06	21.45	4.68	31.24	Peak	---	---



Test mode	Mode 2	Test Site No.	OS02-NH
Test frequency	30 MHz ~ 1000 MHz	Test Engineer	Chas
Temperature	26 °C	Relative Humidity	51 %
Note: 1. Emission level (dB μ V/m) = 20 log Emission level (μ V/m)			
2. Corrected Reading : Probe Factor + Cable Loss + Read Level – Preamp Factor = Level			
■The test was passed at the minimum margin that marked by the frame in the following data			

Vertical

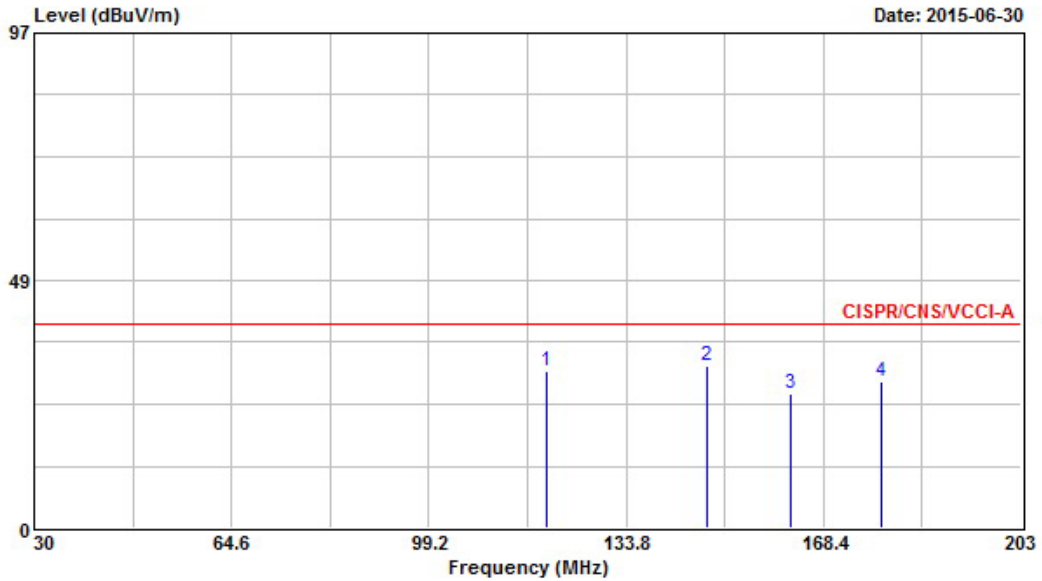

	Freq	Level	Over Limit	Limit Line	ReadAntenna Level	Antenna Factor	Cable Loss	Preamp Factor	Remark	Ant Pos	Table Pos
	MHz	dBuV/m	dB	dBuV/m	dBuV	dB/m	dB	dB		cm	deg
1	119.960	30.78	-9.22	40.00	48.66	12.30	1.45	31.63	Peak	---	---
2	147.990	31.91	-8.09	40.00	51.19	10.67	1.62	31.57	Peak	---	---
3	162.690	26.34	-13.66	40.00	46.16	10.01	1.71	31.54	Peak	---	---
4	178.610	28.70	-11.30	40.00	48.92	9.49	1.79	31.50	Peak	---	---



Vertical

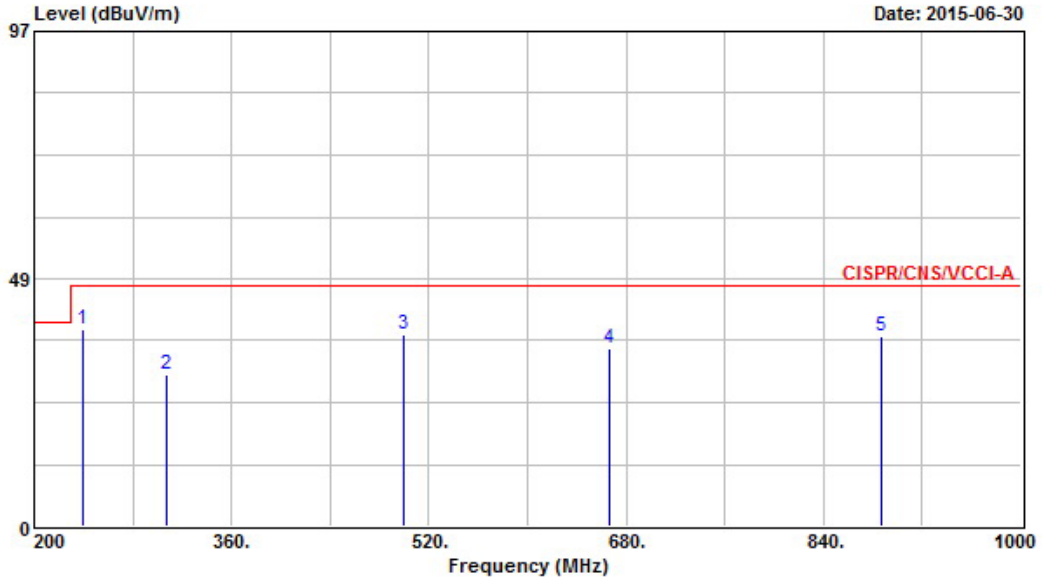

	Freq	Level	Over Limit	Limit Line	ReadAntenna Level	Antenna Factor	Cable Loss	Preamp Factor	Remark	Ant Pos	Table Pos
	MHz	dBuV/m	dB	dBuV/m	dBuV	dB/m	dB	dB		cm	deg
1	240.000	38.68	-8.32	47.00	56.16	11.81	2.13	31.42	Peak	---	---
2	307.200	29.77	-17.23	47.00	45.23	13.52	2.40	31.38	Peak	---	---
3	499.200	37.46	-9.54	47.00	48.03	17.56	3.21	31.34	Peak	---	---
4	666.400	34.89	-12.11	47.00	43.13	19.19	3.86	31.29	Peak	---	---
5	886.400	37.08	-9.92	47.00	42.63	21.14	4.59	31.28	Peak	---	---



Horizontal

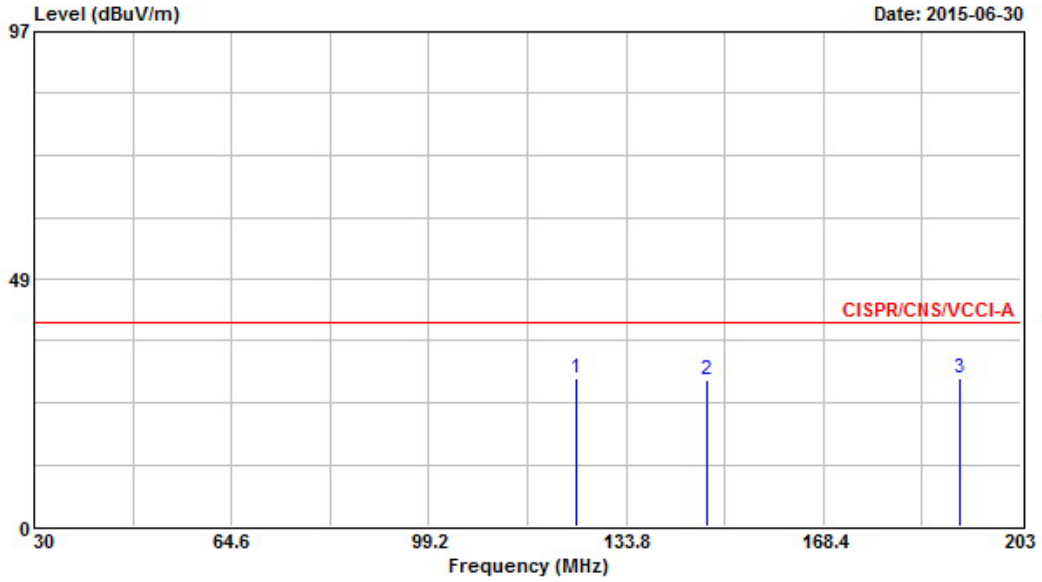

	Freq	Level	Over Limit	Limit Line	Headantenna Level	Antenna Factor	Cable Loss	Preamp Factor	Remark	Ant Pos	Table Pos
	MHz	dBuV/m	dB	dBuV/m	dBuV	dB/m	dB	dB		cm	deg
1	124.980	29.09	-10.91	40.00	47.03	12.21	1.47	31.62	Peak	---	---
2	147.990	28.77	-11.23	40.00	48.05	10.67	1.62	31.57	Peak	---	---
3	192.450	29.12	-10.88	40.00	49.24	9.41	1.94	31.47	Peak	---	---

Horizontal

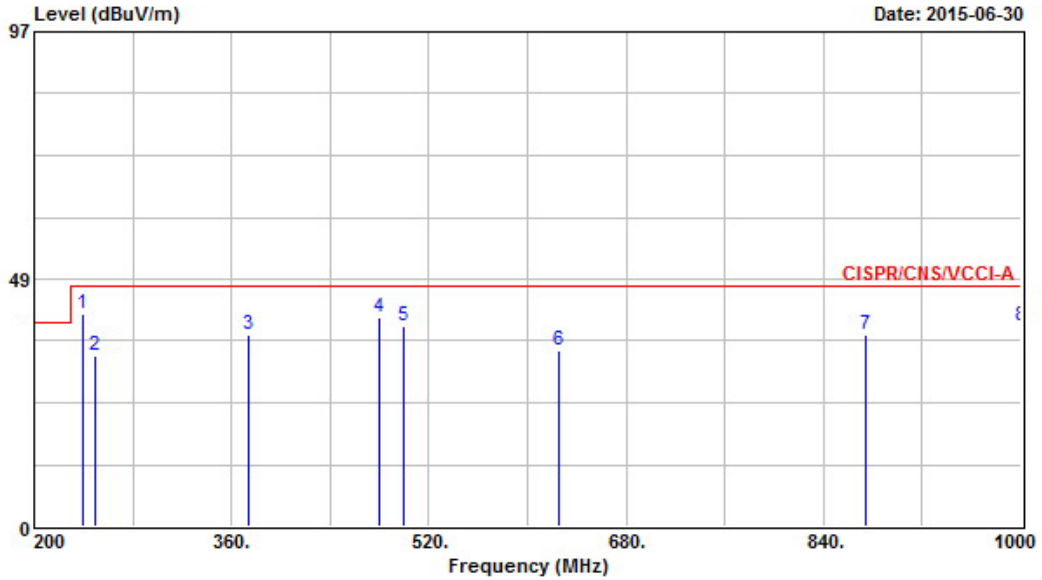

	Freq	Level	Over Limit	Limit Line	ReadAntenna Level	Antenna Factor	Cable Loss	Preamp Factor	Remark	Ant Pos	Table Pos
	MHz	dBuV/m	dB	dBuV/m	dBuV	dB/m	dB	dB		cm	deg
1 @	240.000	41.75	-5.25	47.00	59.23	11.81	2.13	31.42	Peak	400	180
2	249.600	33.42	-13.58	47.00	50.28	12.39	2.17	31.42	Peak	---	---
3	374.400	37.71	-9.29	47.00	51.19	15.15	2.74	31.37	Peak	---	---
4 @	480.000	41.03	-5.97	47.00	52.04	17.21	3.13	31.35	Peak	---	---
5 @	499.200	39.27	-7.73	47.00	49.84	17.56	3.21	31.34	Peak	---	---
6	624.800	34.34	-12.66	47.00	43.01	18.97	3.69	31.33	Peak	---	---
7	874.400	37.73	-9.27	47.00	43.42	21.06	4.54	31.29	Peak	---	---
8 @	1000.000	39.23	-7.77	47.00	43.31	22.13	4.89	31.10	Peak	---	---

NOTE. Equipment was not exceed the radiated emission limits specified in 15.109 and 15.32 by more than 6dB.



6.3 Test Result of Radiated Emission (Above 1GHz)

Test mode	Mode 1	Test Site No.	03CH04-HY
Test frequency	1 GHz ~ 10 GHz	Test Engineer	Alan
Temperature	23 °C	Relative Humidity	50 %
Note: 1. Emission level (dBμV/m) = 20 log Emission level (μV/m)			
2. Corrected Reading : Antenna Factor + Cable Loss + Read Level – Preamp Factor = Level			
■ The test was passed at the minimum margin that marked by the frame in the following data			

Vertical

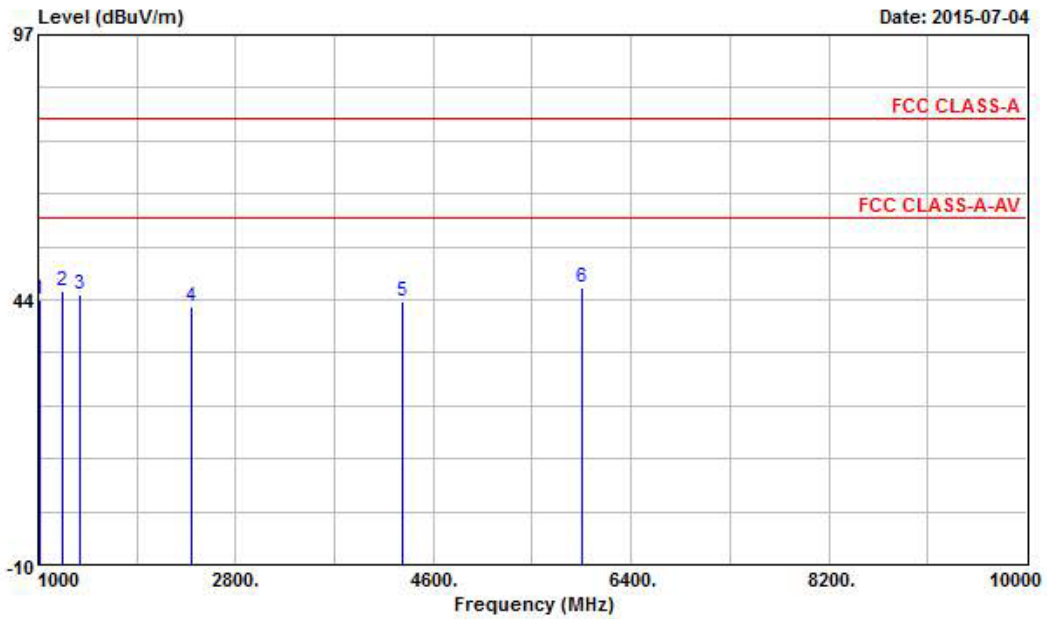

	Freq	Level	Over Limit	Limit Line	Read Level	Antenna Factor	Preamp Factor	Cable Loss	Ant Pos	Table Pos	Remark
	MHz	dBuV/m	dB	dBuV/m	dBuV	dB/m	dB	dB	cm	deg	
1	1014.000	43.45	-36.55	80.00	51.12	24.55	34.07	1.85	---	---	Peak
2	1230.000	45.12	-34.88	80.00	51.70	25.18	33.78	2.02	---	---	Peak
3	1388.000	44.60	-35.40	80.00	50.41	25.61	33.56	2.14	---	---	Peak
4	2398.000	41.96	-38.04	80.00	45.39	27.27	33.49	2.78	---	---	Peak
5	4317.000	43.14	-36.86	80.00	42.79	30.43	33.81	3.72	---	---	Peak
6	5958.000	45.92	-34.08	80.00	42.53	32.66	33.76	4.49	---	---	Peak



Horizontal

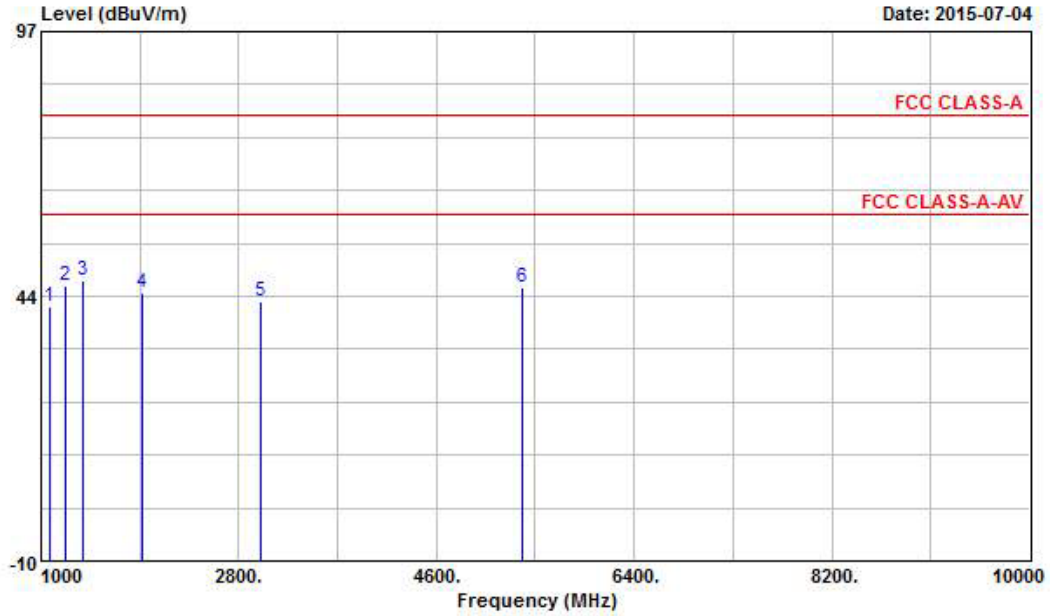

	Freq	Level	Over Limit	Limit Line	Read Level	Antenna Factor	Preamp Factor	Cable Loss	Ant Pos	Table Pos	Remark
	MHz	dBUV/m	dB	dBUV/m	dBUV	dB/m	dB	dB	cm	deg	
1	1076.000	41.32	-38.68	80.00	48.72	24.69	34.00	1.91	---	---	Peak
2	1230.000	45.69	-34.31	80.00	52.27	25.18	33.78	2.02	---	---	Peak
3	1388.000	46.67	-33.33	80.00	52.48	25.61	33.56	2.14	100	200	Peak
4	1918.000	44.26	-35.74	80.00	48.87	26.32	33.33	2.41	---	---	Peak
5	3000.000	42.54	-37.46	80.00	44.66	28.70	33.81	2.99	---	---	Peak
6	5385.000	45.42	-34.58	80.00	42.97	32.03	33.73	4.15	---	---	Peak



Test mode	Mode 2	Test Site No.	03CH04-HY
Test frequency	1 GHz ~ 10 GHz	Test Engineer	Alan
Temperature	23 °C	Relative Humidity	50 %
Note: 1. Emission level (dBµV/m) = 20 log Emission level (µV/m)			
2. Corrected Reading : Antenna Factor + Cable Loss + Read Level – Preamp Factor = Level			
■ The test was passed at the minimum margin that marked by the frame in the following data			

Vertical

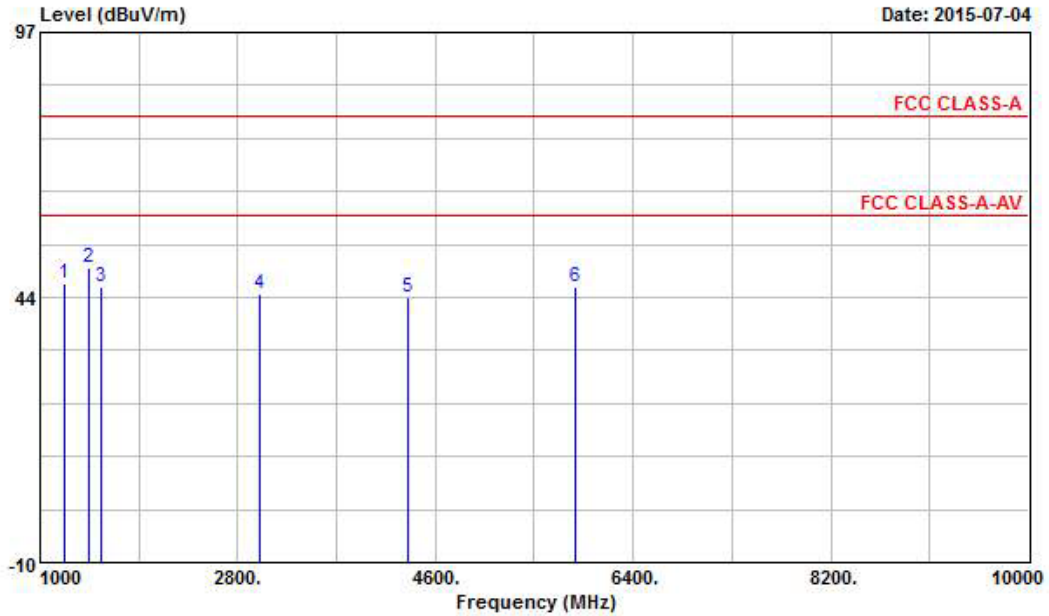

	Freq	Level	Over Limit	Limit Line	Read Level	Antenna Factor	Preamp Factor	Cable Loss	Ant Pos	Table Pos	Remark
	MHz	dBuV/m	dB	dBuV/m	dBuV	dB/m	dB	dB	cm	deg	
1	1230.000	46.17	-33.83	80.00	52.75	25.18	33.78	2.02	---	---	Peak
2 @	1438.000	49.43	-30.57	80.00	55.00	25.76	33.49	2.17	100	187	Peak
3	1550.000	45.60	-34.40	80.00	50.78	25.95	33.37	2.24	---	---	Peak
4	3000.000	44.33	-35.67	80.00	46.45	28.70	33.81	2.99	---	---	Peak
5	4350.000	43.56	-36.44	80.00	43.12	30.50	33.81	3.75	---	---	Peak
6	5874.000	45.51	-34.49	80.00	42.28	32.56	33.75	4.43	---	---	Peak



Horizontal

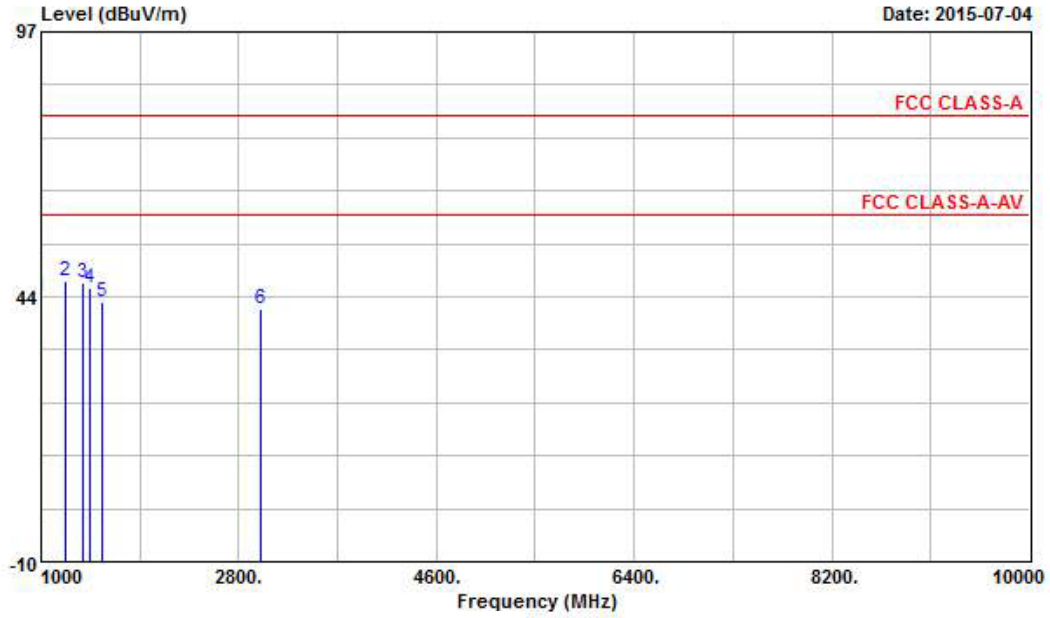

	Freq	Level	Over Limit	Limit Line	Read Level	Antenna Factor	Preamp Factor	Cable Loss	Ant Pos	Table Pos	Remark
	MHz	dBuV/m	dB	dBuV/m	dBuV	dB/m	dB	dB	cm	deg	
1	1000.000	43.61	-36.39	80.00	51.37	24.50	34.11	1.85	---	---	Peak
2 @	1230.000	46.72	-33.28	80.00	53.30	25.18	33.78	2.02	---	---	Peak
3	1388.000	46.26	-33.74	80.00	52.07	25.61	33.56	2.14	---	---	Peak
4	1438.000	45.40	-34.60	80.00	50.97	25.76	33.49	2.17	---	---	Peak
5	1550.000	42.33	-37.67	80.00	47.51	25.95	33.37	2.24	---	---	Peak
6	3000.000	41.14	-38.86	80.00	43.26	28.70	33.81	2.99	---	---	Peak



7. List of Measuring Equipment Used

< Conducted Emission >

Instrument	Manufacturer	Model No.	Serial No.	Characteristics	Calibration Date	Remark
Receiver	R&S	ESCS 30	100357	9 kHz - 2.75 GHz	Jan. 21, 2015	Conduction (CO01-NH)
LISN	SCHAFFNER	NNB41	06/10024	9kHz - 30MHz	Dec. 04, 2014	Conduction (CO01-NH)
LISN	KYORITSU	KNW-407	8-1010-15	9kHz - 30MHz	NCR	Conduction (CO01-NH)
Power Filter	CORCOM	MR12030	N/A	30A*2	NCR	Conduction (CO01-NH)
RF Cable-CON	Suhner Switzerland	RG223/U	CB004	9kHz - 30MHz	Dec. 10, 2014	Conduction (CO01-NH)

Note: Calibration Interval of instruments listed above is one year. NCR: NO CALIBRATION REQUEST.

< Radiated Emission below 1GHz >

Instrument	Manufacturer	Model No.	Serial No.	Characteristics	Calibration Date	Remark
Open Area Test Site	SPORTON	OATS-10	OS02-NH	30 MHz - 1 GHz 10m, 3m	Dec. 29, 2014	Radiation (OS02-NH)
Amplifier	BURGEON	BPA-530	100203	0.01 MHz - 3 GHz	May 20, 2015	Radiation (OS02-NH)
Receiver	R&S	ESCI	100497	9 kHz - 3 GHz	May 07, 2015	Radiation (OS02-NH)
Bilog Antenna	CHASE	CBL6122B	2884	30 MHz - 2 GHz	Feb. 28, 2015	Radiation (OS02-NH)
Turn Table	EMCO	2080	9508-1805	0 - 360 degree	NCR	Radiation (OS02-NH)
Antenna Mast	ETS	2075-2	2385	1 m - 4 m	NCR	Radiation (OS02-NH)
RF Cable-R10m	MIYAZAKI	5DFB	CB044	30 MHz - 1 GHz	Aug. 29, 2014	Radiation (OS02-NH)

Note: Calibration Interval of instruments listed above is one year. NCR: NO CALIBRATION REQUEST.



< Radiated Emission above 1GHz >

Instrument	Manufacturer	Model No.	Serial No.	Characteristics	Calibration Date	Remark
Receiver	R&S	ESU	100422	20Hz ~ 26.5GHz	Jun. 19, 2015	Radiation (03CH04-HY)
Amplifier	Agilent	8449B	3008A02326	1GHz ~ 26.5GHz	May 08, 2015	Radiation (03CH04-HY)
Horn Antenna	SCHWARZBECK	BBHA9120	BBHA9120D1130	1 GHz ~ 18 GHz	Sep. 16, 2014	Radiation (03CH04-HY)
Turn Table	Chaintek	3000	MF7802056	0 ~ 360 degree	NCR	Radiation (03CH04-HY)
Antenna Mast	MF	MF-7802	MF780208163	1 m ~ 4 m	NCR	Radiation (03CH04-HY)
RF Cable-HIGH	SUHNER	SUCOFLEX 106	CB065-HF	1 GHz ~ 40 GHz	Nov. 12, 2014	Radiation (03CH04-HY)

Note: Calibration Interval of instruments listed above is one year. NCR: NO CALIBRATION REQUEST.



8. Notice for Class A Product

This Notice is for class A product only. If the Equipment under Test is a class B product, this notice should be disregarded.

Class A ITE is a category of all other ITE which satisfies the class A ITE limits but not the class B ITE limits. Such equipment should not be restricted in its sale but the following warning shall be included in the instructions for use:

Warning

This is a class A product. In a domestic environment this product may cause radio interference in which case the user may be required to take adequate measures.

Appendix A. Test Photos

1. Photographs of Conducted Emissions Test Configuration

Front view



Rear view

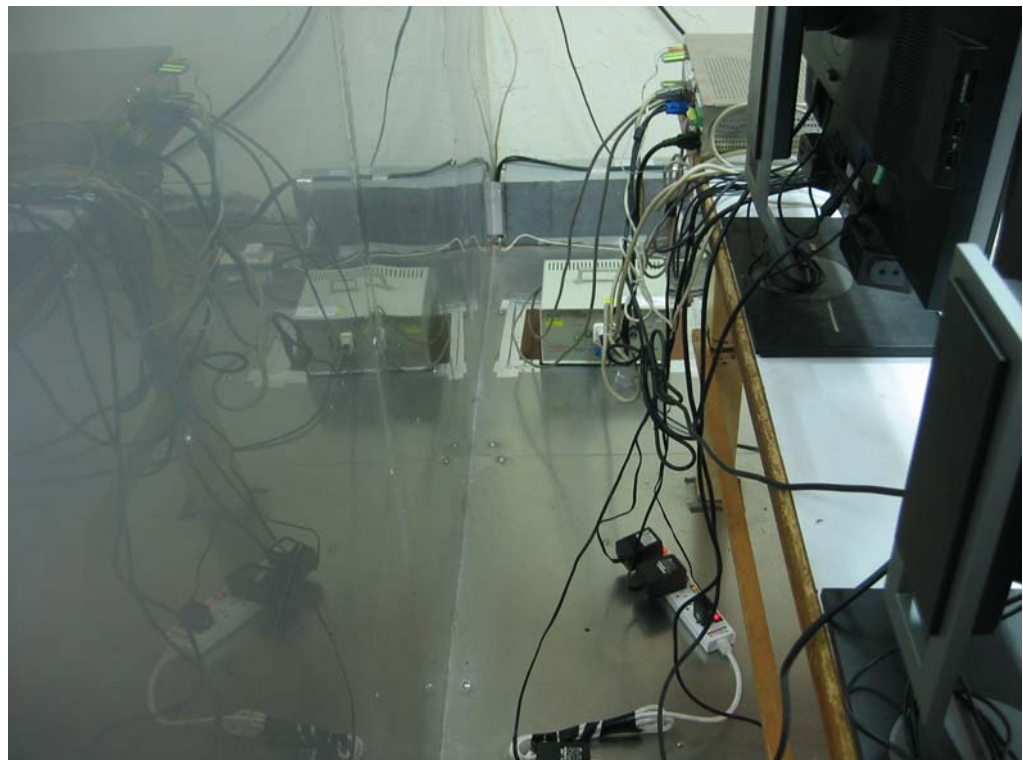

Side view

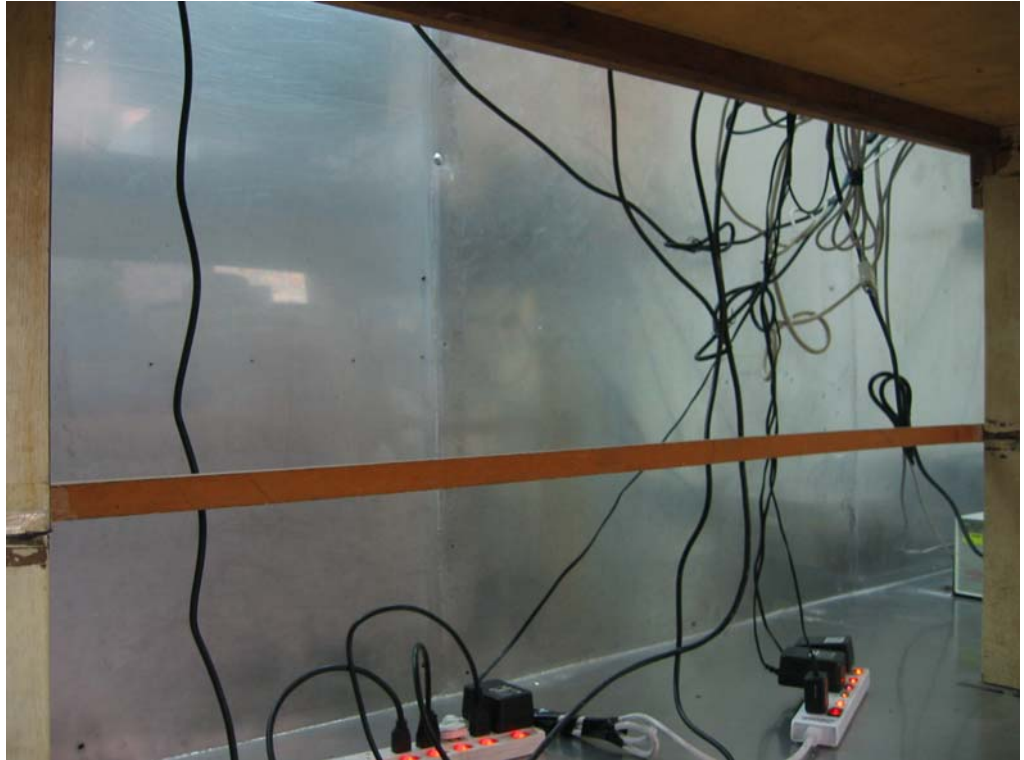

2. Photographs of Radiated Emissions Test Configuration

For radiated emissions below 1GHz

Mode 1

Front view



Rear view

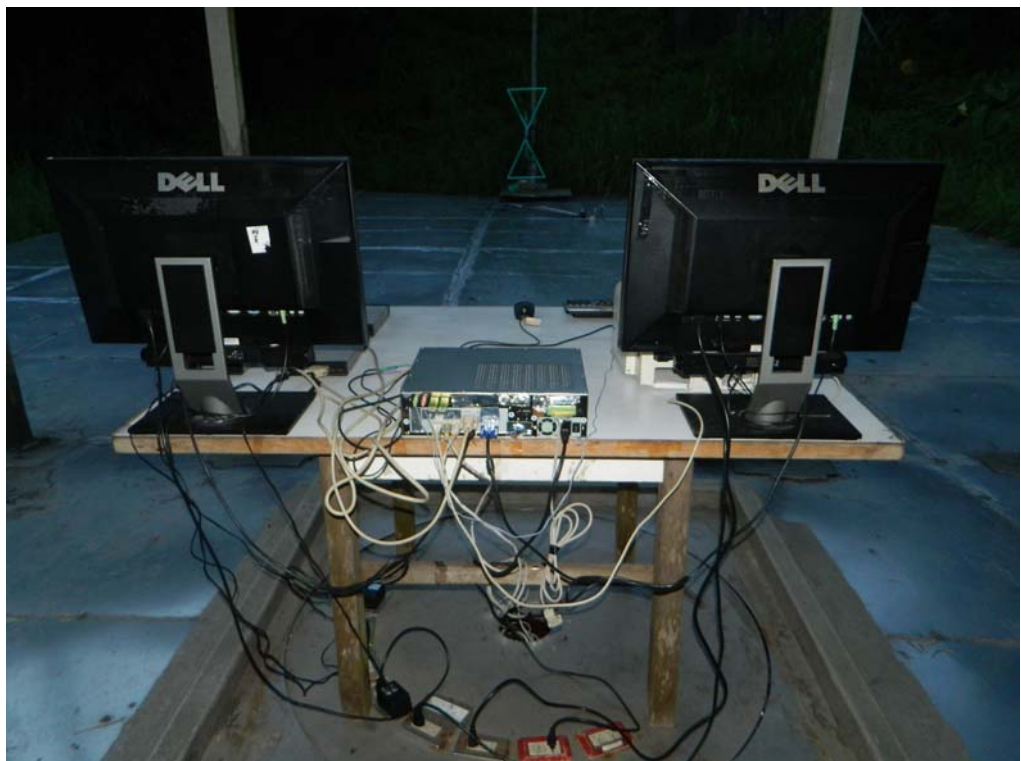

Mode 2

Front view



Rear view

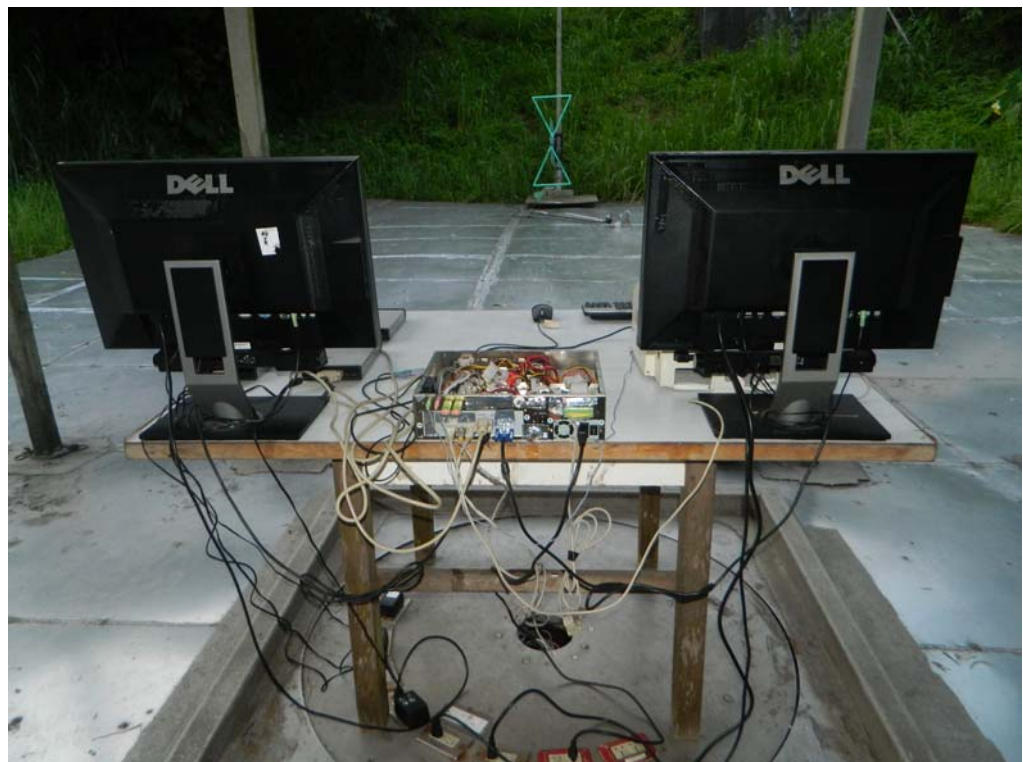

For radiated emissions above 1GHz
Mode 1

Front view

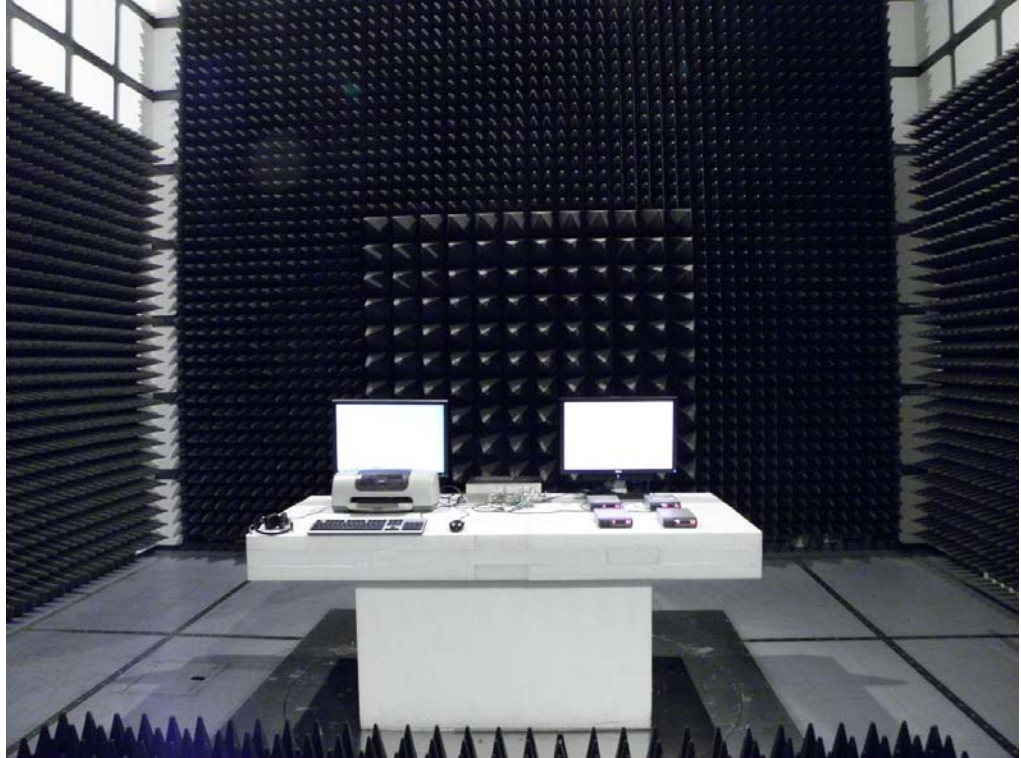

Rear view

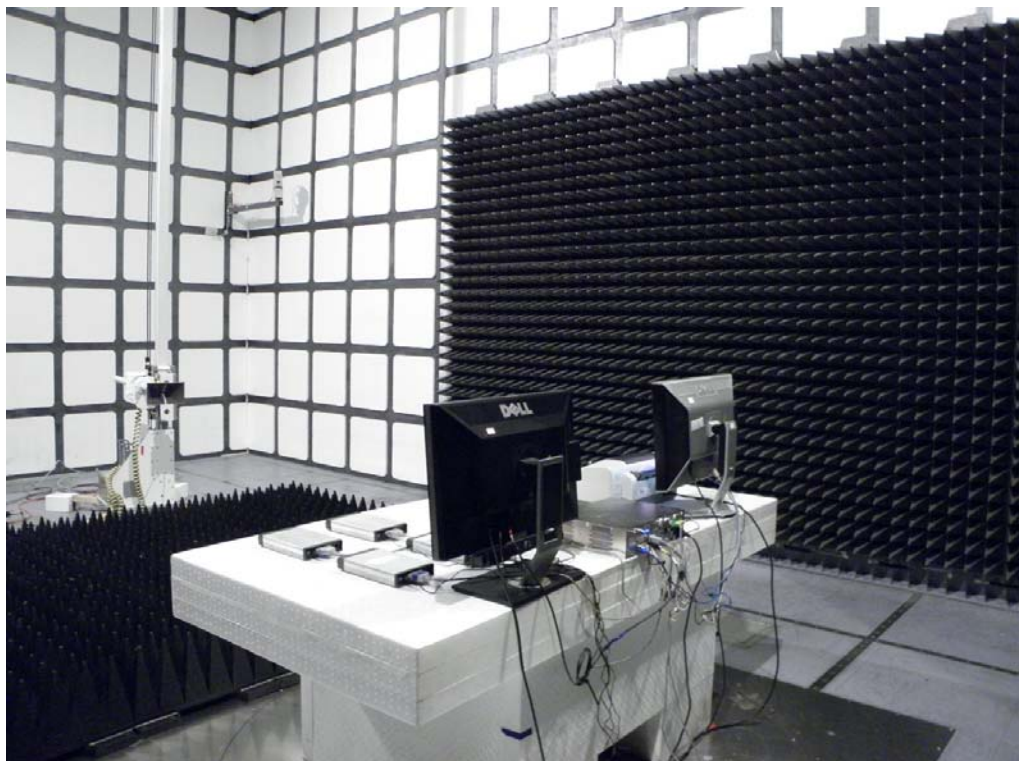

Mode 2

Front view



Rear view

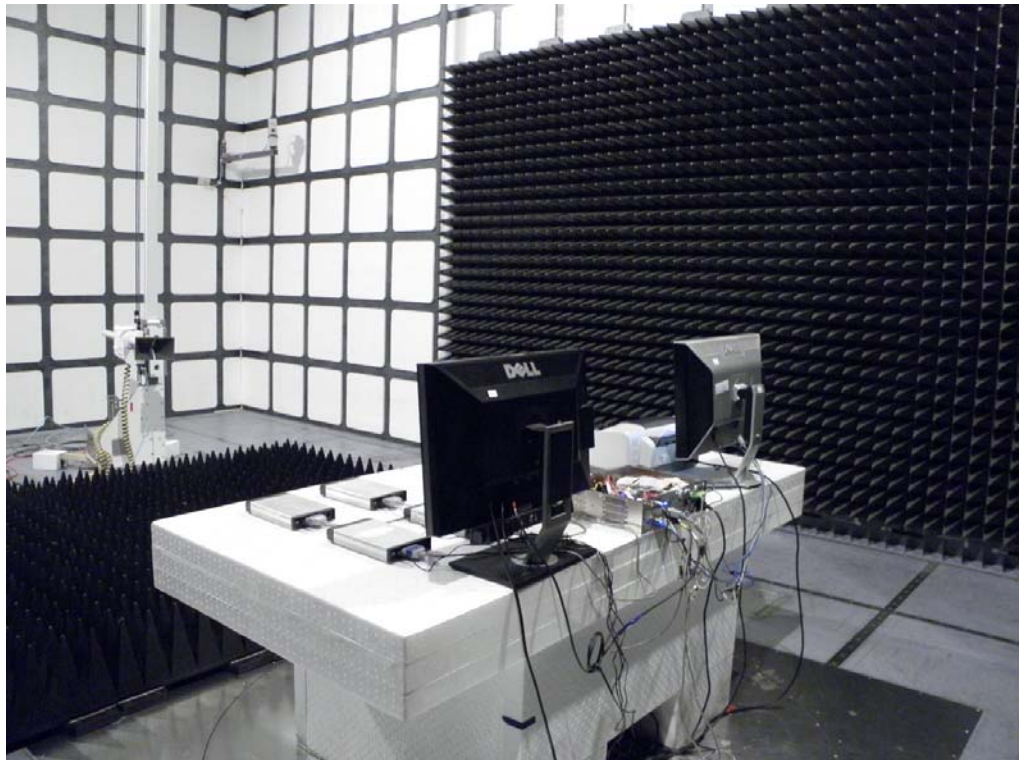

APPENDIX B. Photographs of EUT

