



# FCC Test Report

**Issued Date** : Oct. 28, 2010  
**Project No.** : E0911006B  
**Equipment** : SubCompact Board  
**Model Name** : GENE-9455-Bxxxxxx (Where x is 0-9, A-Z, - or blank) for marketing purpose

**Applicant** : AAEON Technology Inc.  
**Address** : 5F, No. 135, Lane 235, Pao Chiao Rd., Hsin-Tien City, Taipei, Taiwan, R.O.C.

**Tested by:** Neutron Engineering Inc. EMC Laboratory  
**Date of Receipt:** Nov. 04, 2009  
**Date of Test:** Nov. 04, 2009 ~ Nov. 13, 2009

**Testing Engineer:** Josh Li  
(Josh Li)

**Technical Manager:** Jeff Yang  
(Jeff Yang)

**Authorized Signatory:** Andy Chiu  
(Andy Chiu)

**Neutron Engineering Inc.**  
B1, No. 37, Lane 365, YangGuang St.,  
NeiHu District 114, Taipei, Taiwan.  
TEL: +886-2-2657-3299  
FAX: +886-2-2657-3331





**Declaration**

**Neutron** represents to the client that testing is done in accordance with standard procedures as applicable and that test instruments used has been calibrated with the standards traceable to National Measurement Laboratory (**NML**) of **R.O.C.**, or National Institute of Standards and Technology (**NIST**) of **U.S.A.**

**Neutron's** reports apply only to the specific samples tested under conditions. It is manufacture's responsibility to ensure that additional production units of this model are manufactured with the identical electrical and mechanical components. **Neutron** shall have no liability for any declarations, inferences or generalizations drawn by the client or others from **Neutron** issued reports.

**Neutron's** reports must not be used by the client to claim product endorsement by the authorities or any agency of the Government.

This report is the confidential property of the client. As a mutual protection to the clients, the public and **Neutron-self**, extracts from the test report shall not be reproduced except in full with **Neutron's** authorized written approval.

**Neutron's** laboratory quality assurance procedures are in compliance with the **ISO Guide 17025** requirements, and accredited by the conformity assessment authorities listed in this test report.

**Limitation**

For the use of the authority's logo is limited unless the Test Standard(s)/Scope(s)/Item(s) mentioned in this test report is (are) included in the conformity assessment authorities acceptance respective.



<b>Table of Contents</b>	<b>Page</b>
<b>1 . CERTIFICATION</b>	<b>4</b>
<b>2 . SUMMARY OF TEST RESULTS</b>	<b>5</b>
2.1 TEST FACILITY	6
2.2 MEASUREMENT UNCERTAINTY	6
<b>3 . GENERAL INFORMATION</b>	<b>7</b>
3.1 GENERAL DESCRIPTION OF EUT	7
3.2 DESCRIPTION OF TEST MODES	8
3.3 BLOCK DIAGRAM SHOWING THE CONFIGURATION OF SYSTEM TESTED	9
3.4 DESCRIPTION OF SUPPORT UNITS	10
<b>4 . EMC EMISSION TEST</b>	<b>11</b>
4.1 CONDUCTED EMISSION MEASUREMENT	11
4.1.1 POWER LINE CONDUCTED EMISSION	11
4.1.2 MEASUREMENT INSTRUMENTS LIST	11
4.1.3 TEST PROCEDURE	12
4.1.4 DEVIATION FROM TEST STANDARD	12
4.1.5 TEST SETUP	12
4.1.6 EUT OPERATING CONDITIONS	13
4.1.7 TEST RESULTS	14
4.2 RADIATED EMISSION MEASUREMENT	16
4.2.1 LIMITS OF RADIATED EMISSION MEASUREMENT	16
4.2.2 MEASUREMENT INSTRUMENTS LIST	17
4.2.3 TEST PROCEDURE	17
4.2.4 DEVIATION FROM TEST STANDARD	17
4.2.5 TEST SETUP	18
4.2.6 EUT OPERATING CONDITIONS	18
4.2.7 TEST RESULTS-BETWEEN 30MHZ AND 1000MHZ	19
4.2.8 TEST RESULTS-ABOVE 1000MHZ	23
<b>5 . EUT TEST PHOTO</b>	<b>27</b>



## 1. CERTIFICATION

Equipment: SubCompact Board  
Brand Name: AAEON  
Model Name: GENE-9455-Bxxxxxx (Where x is 0-9, A-Z, - or blank) for marketing purpose  
Applicant: AAEON Technology Inc.  
Date of Test: Nov. 04, 2009 ~ Nov. 13, 2009  
Standards: FCC Part 15, Subpart B, Class A  
CISPR 22: 1997+A1: 2000, Class A  
ICES-003: 2004, Class A  
ANSI C63.4-2003

The above equipment has been tested and found compliance with the requirement of the relative standards by Neutron Engineering Inc. EMC Laboratory.

The test data, data evaluation, and equipment configuration contained in our test report (Ref No. NEI-FCCE-1-E0911006B) were obtained utilizing the test procedures, test instruments, test sites that has been accredited by the Authority of NVLAP and TAF according to the ISO-17025 quality assessment standard and technical standard(s).



## 2. SUMMARY OF TEST RESULTS

Test procedures according to the technical standards:

Emission				
Standard	Test Item	Limit	Judgment	Remark
FCC Part15, Subpart B CISPR 22:1997+A1: 2000 ICES-003: 2004	Conducted Emission	Class A	PASS	
	Radiated Emission	Class A	PASS	

**NOTE:**

- (1) " N/A" denotes test is not applicable in this Test Report.
- (2) According to FCC Part 15 Support B 15.32 (a)(1)(i), the EUT(CPU Board) should be tested under two conditions: Open case & Close case for Radiated test.  
And the test data can't be over 6dB against the limit under the Open case condition.  
\*Normal test condition is close case.



**2.1 TEST FACILITY**

The test facilities used to collect the test data in this report is **C01/OS01/CB03** at the location of No.132-1, Lane 329, Sec. 2, Palian Road, Shijr City, Taipei, Taiwan.

**2.2 MEASUREMENT UNCERTAINTY**

The reported uncertainty of measurement  $y \pm U$ , where expended uncertainty **U** is based on a standard uncertainty multiplied by a coverage factor of **k=2**, providing a level of confidence of approximately **95%**.

A. Conducted Measurement :

Test Site	Method	Measurement Frequency Range	U , (dB)	NOTE
C01	ANSI	150 KHz ~ 30MHz	1.94	

B. Radiated Measurement :

Test Site	Method	Measurement Frequency Range	Ant. H / V	U , (dB)	NOTE
OS-01	ANSI	30MHz ~ 200MHz	V	2.86	
		30MHz ~ 200MHz	H	2.56	
		200MHz ~ 1,000MHz	V	2.88	
		200MHz ~ 1,000MHz	H	2.98	
OS-02	ANSI	30MHz ~ 200MHz	V	2.48	
		30MHz ~ 200MHz	H	2.16	
		200MHz ~ 1,000MHz	V	2.50	
		200MHz ~ 1,000MHz	H	2.66	



**3. GENERAL INFORMATION**

**3.1 GENERAL DESCRIPTION OF EUT**

Equipment	SubCompact Board
Brand Name	AAEON
Model Name	GENE-9455-Bxxxxxx (Where x is 0-9, A-Z, - or blank) for marketing purpose
OEM Brand/Model Name	N/A
Model Difference	Models' differences between each other only the changes of model name which do not affect the EMI performance. Model GENE-9455-Bxxxxxx was used for final testing and collecting test data included in this report.
Product Description	The EUT is a SubCompact Board. Based on the application, features, or specification exhibited in User's Manual, the EUT is considered as an ITE/Computing Device. More details of EUT technical specification, please refer to the User's Manual.
Power Source	DC Voltage supplied from AC/DC adapter.
Power Rating	12VDC
Connecting I/O Port(s)	Please refer to the User's Manual
Products Covered	CPU(on board): Intel Atom N270 1.6GHz CFD: Transcend 4GB Memory: Kingston, DDR2-533 256MB / KVR533D2S4/256
EUT Modification(s)	N/A

**Note:**

1. For a more detailed features description, please refer to the manufacturer's specifications or the User's Manual.



### 3.2 DESCRIPTION OF TEST MODES

To investigate the maximum EMI emission characteristics generates from EUT, the test system was pre-scanning tested base on the consideration of following EUT operation mode or test configuration mode which possible have effect on EMI emission level. Each of these EUT operation mode(s) or test configuration mode(s) mentioned above was evaluated respectively.

Pretest Test Mode	Description
Mode 1	D-SUB 1920*1080/60Hz
Mode 2	S-VIDEO
Mode 3	VIDEO
Mode 4	D-SUB 1024*768/60Hz+VIDEO
Mode 5	D-SUB 1024*768/60Hz +S-VIDEO

For Conducted Test	
Final Test Mode	Description
Mode 4	D-SUB 1024*768/60Hz+VIDEO

For Radiated Test	
Final Test Mode	Description
Mode 4	D-SUB 1024*768/60Hz+VIDEO



### 3.3 BLOCK DIAGRAM SHOWING THE CONFIGURATION OF SYSTEM TESTED

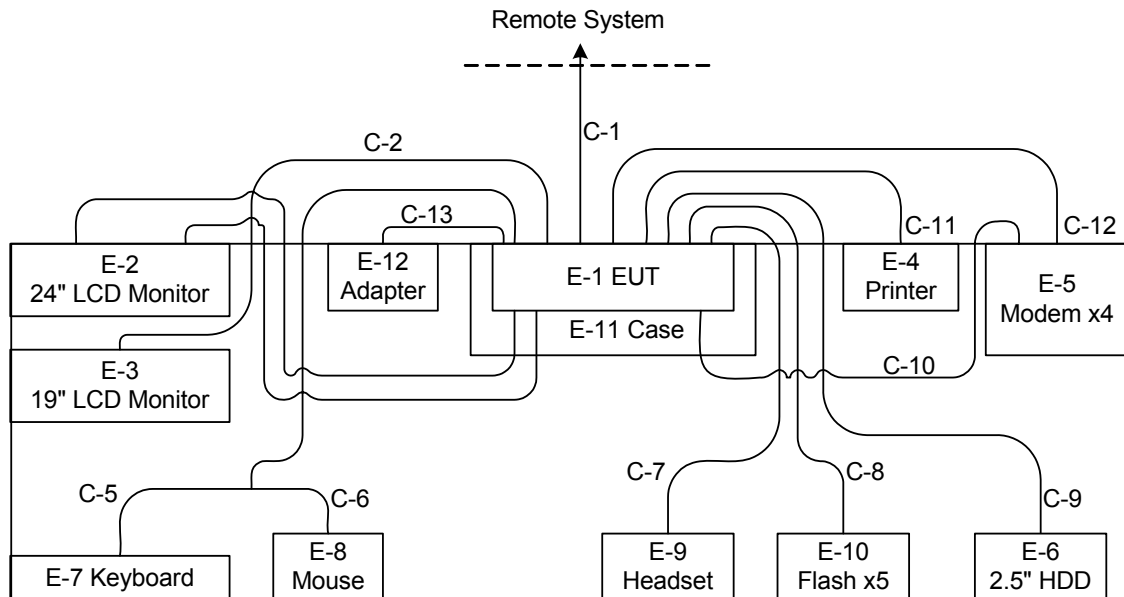

- |                    |                     |
|--------------------|---------------------|
| C-1 RJ-45 Cable    | C-10 RS232 Cable x2 |
| C-2 D-SUB Cable    | C-11 Parallel Cable |
| C-3 Video Cable    | C-12 RS232 Cable x2 |
| C-4 S-Video Cable  | C-13 Power Cable    |
| C-5 PS/2 Cable     |                     |
| C-6 PS/2 Cable     |                     |
| C-7 Audio Cable x2 |                     |
| C-8 USB Cable x5   |                     |
| C-9 USB Cable      |                     |



**3.4 DESCRIPTION OF SUPPORT UNITS**

The EUT has been tested as an independent unit together with other necessary accessories or support units. The following support units or accessories were used to form a representative test configuration during the tests.

Item	Equipment	Mfr/Brand	Model/Type No.	FCC ID	Series No.	Note
E-1	SubCompact Board	AAEON	GENE-9455-Bxxxxxx	N/A	N/A	EUT
E-2	24" LCD Monitor	DELL	2408WFPb	DOC	071863-11	
E-3	19" LCD Monitor	Samsung	SyncMaster 193P	DOC	DI19H4JXC05517A	
E-4	Printer	SII	DPU-414	DOC	1045105A	
E-5	Modem	ACEEX	DM-1414V	DOC	8041708	
E-6	2.5" Mobile External HDD	FireWire	F12-UF	DOC	N/A	
E-7	PS/2 K/B	Logitech	Y-SJ17(ACK260A)	DOC	SYU44664880	
E-8	PS/2 Mouse	Logitech	M-SBF69	DOC	HCA44601156	
E-9	Headset	Shiern-Chiu	KHM-108	N/A	N/A	
E-10	FLASH	Silicon power	SP004GBUF2M01V1K	DOC	N/A	
E-11	PC CASE	N/A	N/A	N/A	N/A	
E-12	ADAPTER	EDAC	EA1050A-120	DOC	N/A	

Item	Shielded Type	Ferrite Core	Length	Note
C-1	YES	NO	10.0M	
C-2	YES	YES	1.8M	
C-3	YES	NO	1.7M	
C-4	YES	NO	1.6M	
C-5	YES	NO	1.6M	
C-6	YES	NO	1.8M	
C-7	NO	NO	1.8M	
C-8	YES	NO	1.7M	
C-9	YES	NO	1.7M	
C-10	YES	NO	1.7M	
C-11	YES	NO	1.7M	
C-12	YES	NO	1.7M	
C-13	YES	YES	1.2M	

Note:

- (1) The support equipment was authorized by Declaration of Conformity.
- (2) For detachable type I/O cable should be specified the length in cm in 『Length』 column.



**4. EMC EMISSION TEST**

**4.1 CONDUCTED EMISSION MEASUREMENT**

**4.1.1 POWER LINE CONDUCTED EMISSION (FREQUENCY RANGE 150KHZ-30MHZ)**

FREQUENCY (MHz)	Class A (dBuV)		Class B (dBuV)	
	Quasi-peak	Average	Quasi-peak	Average
0.15 -0.5	79.00	66.00	66 - 56 *	56 - 46 *
0.50 -5.0	73.00	60.00	56.00	46.00
5.0 -30.0	73.00	60.00	60.00	50.00

Note:

(1) The tighter limit applies at the band edges.

(2) The limit of " \* " marked band means the limitation decreases linearly with the logarithm of the frequency in the range.

**4.1.2 MEASUREMENT INSTRUMENTS LIST**

Item	Kind of Equipment	Manufacturer	Type No.	Serial No.	Calibrated until
1	LISN	EMCO	3816/2	00042991	Jan. 21, 2010
2	Test Cable	N/A	SR03_C_01 &02	N/A	Aug. 19, 2010
3	Pulse Limiter	Electro-Metrics	EM-7600	112644	Dec. 28, 2009
4	EMI Test Receiver	R&S	ESCI	100082	Mar. 17, 2010
5	50Ω BNC TYPE Terminator	N/A	N/A	01	May 25, 2011
6	50Ω BNC TYPE Terminator	N/A	N/A	03	May 25, 2011
7	LISN	EMCO	4825/2	00028234	Jul. 13, 2010

Remark: " N/A" denotes No Model Name , Serial No. or No Calibration specified.

#### 4.1.3 TEST PROCEDURE

- a. The EUT was placed 0.8 meters from the horizontal ground plane with EUT being connected to the power mains through a line impedance stabilization network (LISN). All other support equipments powered from additional LISN(s). The LISN provide 50 Ohm/ 50uH of coupling impedance for the measuring instrument.
- b. Interconnecting cables that hang closer than 40 cm to the ground plane shall be folded back and forth in the center forming a bundle 30 to 40 cm long.
- c. I/O cables that are not connected to a peripheral shall be bundled in the center. The end of the cable may be terminated, if required, using the correct terminating impedance. The overall length shall not exceed 1 m.
- d. LISN at least 80 cm from nearest part of EUT chassis.
- e. For the actual test configuration, please refer to the related Item –EUT Test Photos.

#### 4.1.4 DEVIATION FROM TEST STANDARD

No deviation

#### 4.1.5 TEST SETUP

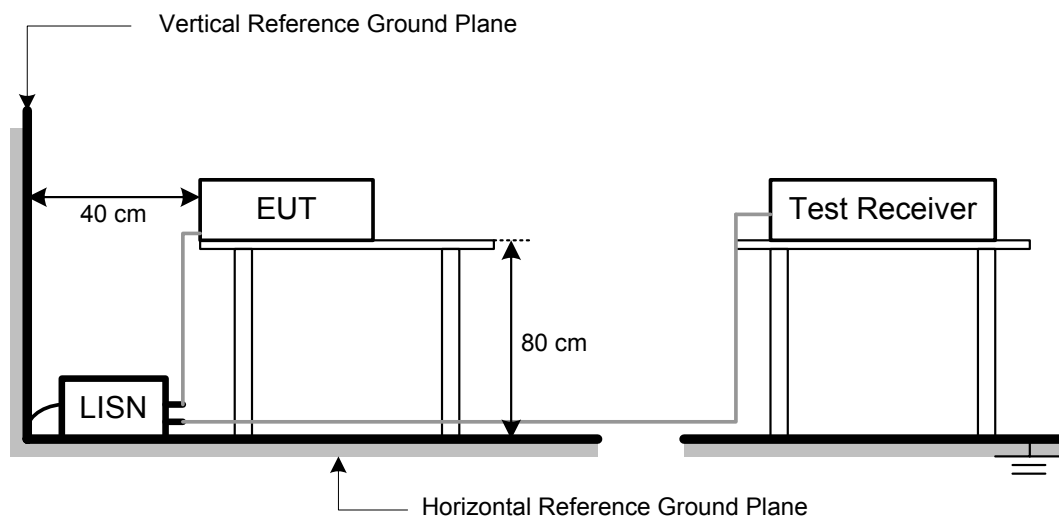



#### **4.1.6 EUT OPERATING CONDITIONS**

The EUT exercise program (EMC.exe) used during radiated and/or conducted emission measurement was designed to exercise the various system components in a manner similar to a typical use. The program contained on a PC hard disk and is auto-starting on power-up. Once loaded, the program sequentially exercises each system component in turn. The sequence used is:

1. Read (write) from (to) mass storage device (HDD & iPod).
2. Send "H" pattern to video port device (Monitor).
3. Send " H " pattern to parallel port device (Printer).
4. Send " H " pattern to serial port device (Modem).
5. Send/Receive data to/from remote system.
6. Send/Receive audio to/from audio devices.
7. Repeated from 2 to 6 continuously.

As the keyboard and mouse are strictly input devices, no data is transmitted to (from) them during test. They are, however, continuously scanned for data input activity.



4.1.7 TEST RESULTS

E.U.T :	SubCompact Board	Model Name :	GENE-9455-Bxxxxxx
Temperature :	24 ° C	Relative Humidity :	47%
Test Voltage :	AC 120V/60Hz		
Test Mode :	D-SUB 1024*768/60Hz+VIDEO		

Freq. (MHz)	Terminal L/N	Measured(dBuV)		Limits(dBuV)		Margin (dB)	Note
		QP-Mode	AV-Mode	QP-Mode	AV-Mode		
0.18	Line	57.30	*	79.00	66.00	-21.70	(QP)
0.25	Line	49.86	*	79.00	66.00	-29.14	(QP)
0.43	Line	45.61	*	79.00	66.00	-33.39	(QP)
1.04	Line	44.65	*	73.00	60.00	-28.35	(QP)
2.22	Line	41.52	*	73.00	60.00	-31.48	(QP)
4.45	Line	45.79	*	73.00	60.00	-27.21	(QP)

Remark

- (1) Reading in which marked as QP means measurements by using are Quasi-Peak Mode with Detector BW=9KHz; SPA setting in RBW=10KHz,VBW =10KHz, Swp. Time = 0.2 sec./MHz ◦ Reading in which marked as AV means measurements by using are Average Mode with instrument setting in RBW=10KHz,VBW=10KHz, Swp. Time =0.2 sec./MHz ◦
- (2) All readings are QP Mode value unless otherwise stated AVG in column of 'Note'. If the QP Mode Measured value compliance with the QP Limits and lower than AVG Limits, the EUT shall be deemed to meet both QP & AVG Limits and then only QP Mode was measured, but AVG Mode didn't perform ◦ In this case, a " \* " marked in AVG Mode column of Interference Voltage Measured ◦
- (3) Measuring frequency range from 150KHz to 30MHz ◦

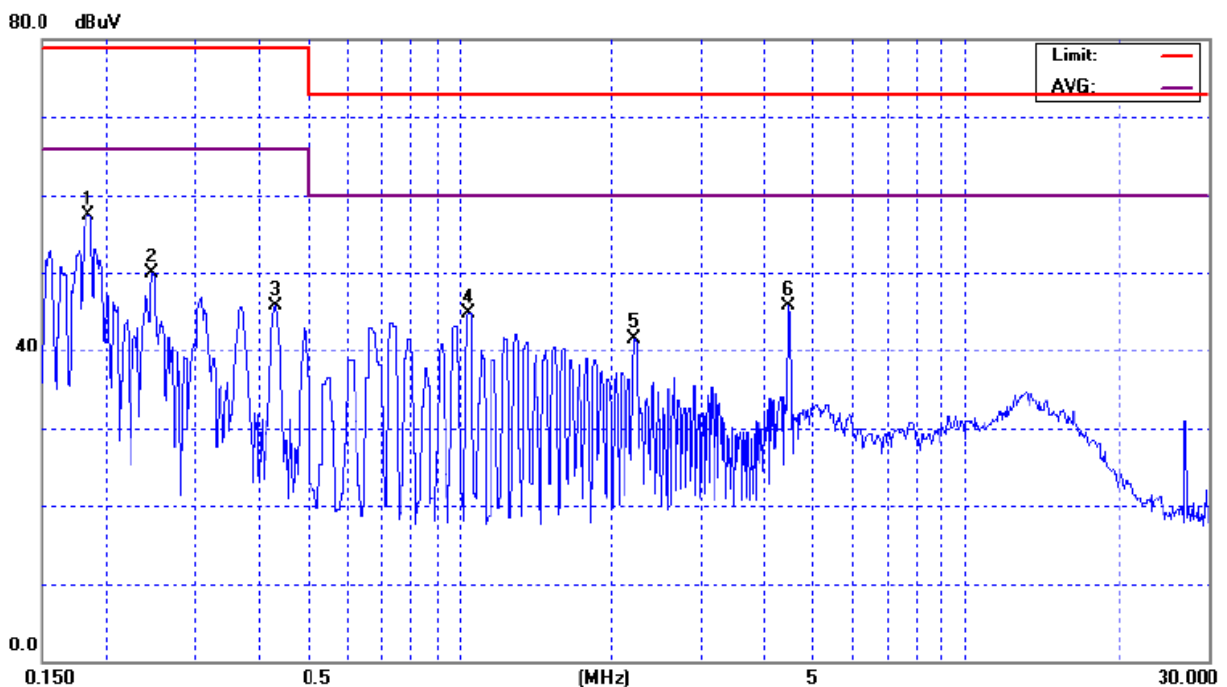



E.U.T :	SubCompact Board	Model Name :	GENE-9455-Bxxxxxx
Temperature :	24 ° C	Relative Humidity :	47%
Test Voltage :	AC 120V/60Hz		
Test Mode :	D-SUB 1024*768/60Hz+VIDEO		

Freq. (MHz)	Terminal L/N	Measured(dBuV)		Limits(dBuV)		Margin (dB)	Note
		QP-Mode	AV-Mode	QP-Mode	AV-Mode		
0.19	Neutral	55.81	*	79.00	66.00	-23.19	(QP)
0.25	Neutral	52.10	*	79.00	66.00	-26.90	(QP)
0.37	Neutral	47.05	*	79.00	66.00	-31.95	(QP)
0.69	Neutral	46.25	*	73.00	60.00	-26.75	(QP)
3.59	Neutral	50.98	*	73.00	60.00	-22.02	(QP)
6.65	Neutral	46.85	*	73.00	60.00	-26.15	(QP)

Remark

- (1) Reading in which marked as QP means measurements by using are Quasi-Peak Mode with Detector BW=9KHz; SPA setting in RBW=10KHz,VBW =10KHz, Swp. Time = 0.2 sec./MHz ◦ Reading in which marked as AV means measurements by using are Average Mode with instrument setting in RBW=10KHz,VBW=10KHz, Swp. Time =0.2 sec./MHz ◦
- (2) All readings are QP Mode value unless otherwise stated AVG in column of 'Note'. If the QP Mode Measured value compliance with the QP Limits and lower than AVG Limits, the EUT shall be deemed to meet both QP & AVG Limits and then only QP Mode was measured, but AVG Mode didn't perform ◦ In this case, a " \* " marked in AVG Mode column of Interference Voltage Measured ◦
- (3) Measuring frequency range from 150KHz to 30MHz ◦

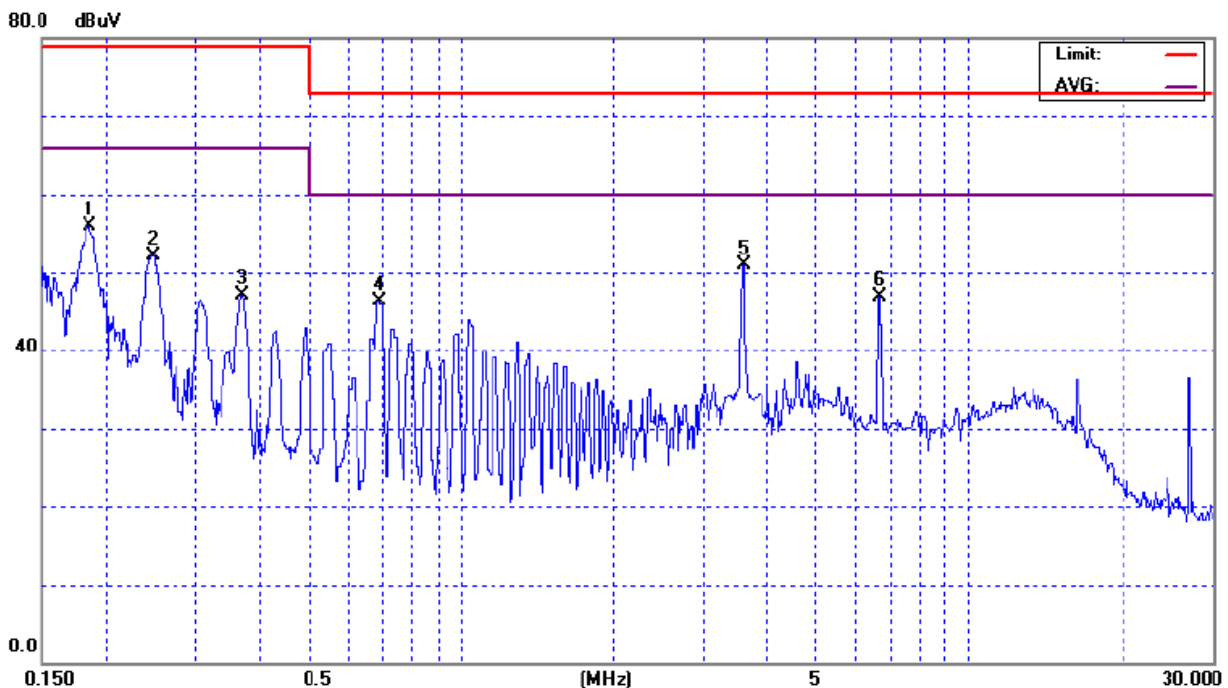



**4.2 RADIATED EMISSION MEASUREMENT**

**4.2.1 LIMITS OF RADIATED EMISSION MEASUREMENT (BELOW 1000MHZ)**

FREQUENCY (MHz)	Class A (at 10m)	Class B (at 10m)
	dBuV/m	dBuV/m
30 – 230	40	30
230 – 1000	47	37

Notes:

- (1) The limit for radiated test was performed according to as following:  
CISPR 22/ FCC PART 15B /ICES-003.
- (2) The tighter limit applies at the band edges.
- (3) Emission level (dBuV/m)=20log Emission level (uV/m).

**LIMITS OF RADIATED EMISSION MEASUREMENT (ABOVE 1000MHZ)**

FREQUENCY (MHz)	Class A (dBuV/m) (at 3m)		Class B (dBuV/m) (at 3m)	
	PEAK	AVERAGE	PEAK	AVERAGE
Above 1000	80	60	74	54

Notes:

- (1) The limit for radiated test was performed according to FCC PART 15B.
- (2) The tighter limit applies at the band edges.
- (3) Emission level (dBuV/m)=20log Emission level (uV/m).

**FREQUENCY RANGE OF RADIATED MEASUREMENT (FOR UNINTENTIONAL RADIATORS)**

Highest frequency generated or Upper frequency of measurement used in the device or on which the device operates or tunes (MHz)	Range (MHz)
Below 1.705	30
1.705 – 108	1000
108 – 500	2000
500 – 1000	5000
Above 1000	5 <sup>th</sup> harmonic of the highest frequency or 40 GHz, whichever is lower





**4.2.2 MEASUREMENT INSTRUMENTS LIST**

Item	Kind of Equipment	Manufacturer	Type No.	Serial No.	Calibrated until
1	Log-Bicon Antenna	Schwarzbeck	VULB 9160	3176	Aug. 3, 2010
2	Pre-Amplifier	Anritsu	MH648A	M09961	Dec. 29, 2009
3	Test Cable	N/A	LMR-400	N/A	Jan. 05, 2010
4	Test Cable	N/A	3M_OS01	N/A	Oct. 07, 2010
5	Test Cable	N/A	OS01-1	01	Jun. 23, 2010
6	EMI Measuring Receiver	SHCAFFNER	SCR 3501	408	Nov. 24.2009
7	Spectrum Analyzer	ADVAN TEST	R3162	140100131	Jun. 18, 2010
8	Positioning Controller (OS01)	MF	MF7802	N/A	N/A
9	Turn Table	Chance Most	CMTB-1.5	N/A	N/A
10	Horn Antenna (1G)	Schwarzbeck	BBHA 9120 D	9120D-325	Dec. 17, 2009
11	Pre-Amplifier (1G)	Agilent	8449B	3008A01714	Apr 20, 2010
12	Microflex Cable (1G)	United Microwave	57793	1m	Jul. 29, 2010
13	Microflex Cable (1G)	United Microwave	A30A30-5006	4M	Jul. 22, 2010
14	Microflex Cable (1G)	N/A	N/A	6M	Jul. 22, 2010
15	Spectrum Analyzer (1G)	R&S	FSP-40	100129	Sep. 10, 2010

Remark: " N/A" denotes No Model Name / Serial No. and No Calibration specified.

**4.2.3 TEST PROCEDURE**

- a. The measuring distance of at 10 m shall be used for measurements at frequency up to 1GHz. For frequencies above 1GHz, any suitable measuring distance may be used.
- b. The EUT was placed on the top of a rotating table 0.8 meters above the ground at a 3m or 10 meter open area test site. The table was rotated 360 degrees to determine the position of the highest radiation.
- c. The height of the equipment or of the substitution antenna shall be 0.8 m; the height of the test antenna shall vary between 1 m to 4 m. Both horizontal and vertical polarizations of the antenna are set to make the measurement.
- d. The initial step in collecting radiated emission data is a spectrum analyzer peak detector mode pre-scanning the measurement frequency range. Significant peaks are then marked and then Quasi Peak detector mode re-measured.
- e. If the Peak Mode measured value compliance with and lower than Quasi Peak Mode Limit, the EUT shall be deemed to meet QP Limits and then no additional QP Mode measurement performed.
- f. For the actual test configuration, please refer to the related Item –EUT Test Photos.

**4.2.4 DEVIATION FROM TEST STANDARD**

No deviation

#### 4.2.5 TEST SETUP

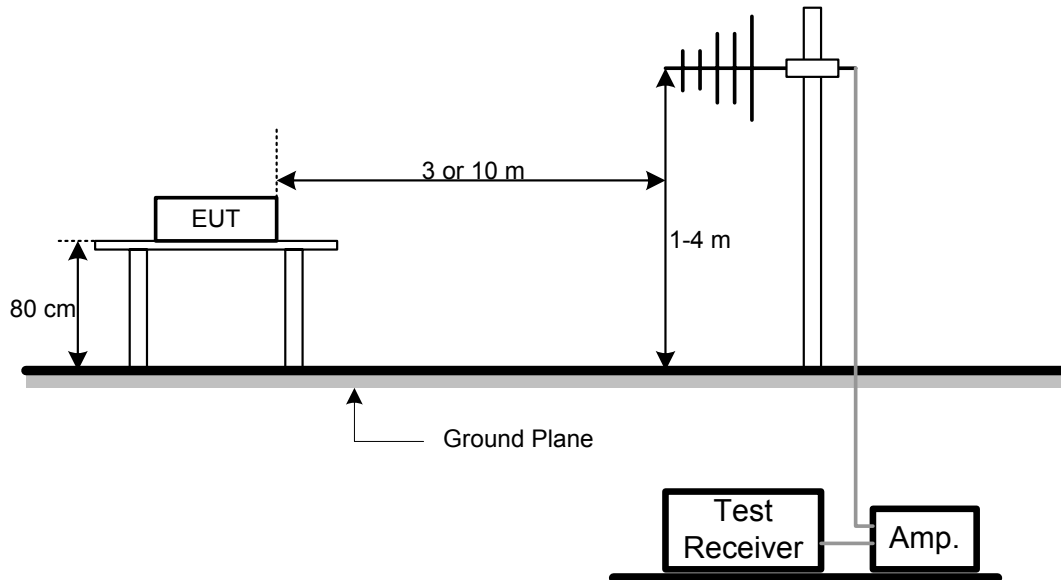

#### 4.2.6 EUT OPERATING CONDITIONS

The EUT tested system was configured as the statements of 4.1.6 Unless otherwise a special operating condition is specified in the follows during the testing.



**4.2.7 TEST RESULTS-BETWEEN 30MHZ AND 1000MHZ**

E.U.T :	SubCompact Board	Model Name :	GENE-9455-Bxxxxxx
Temperature :	25 °C	Relative Humidity :	75%
Test Voltage :	AC 120V/60Hz		
Test Mode :	D-SUB 1024*768/60Hz+VIDEO		

Freq. (MHz)	Ant. H/V	Reading(RA) (dBuV)	Corr.Factor(CF) (dB)	Measured(FS) (dBuV/m)	Limits(QP) (dBuV/m)	Margin (dB)	Note
31.24	V	38.37	-6.60	31.77	40.00	- 8.23	
240.00	V	48.94	-5.75	43.19	47.00	- 3.81	
250.01	V	38.92	-5.44	33.48	47.00	- 13.52	
497.94	V	32.39	0.86	33.25	47.00	- 13.75	
720.01	V	26.56	5.16	31.72	47.00	- 15.28	(QP)
851.32	V	26.73	7.39	34.12	47.00	- 12.88	

Remark :

- (1) Reading in which marked as QP or Peak means measurements by using are Quasi-Peak Mode or Peak Mode with Detector BW=120KHz ; SPA setting in RBW=120KHz, VBW =120KHz, Swp. Time = 0.3 sec./MHz ◦
- (2) All readings are Peak unless otherwise stated QP in column of 『Note』 . Peak denotes that the Peak reading compliance with the QP Limits and then QP Mode measurement didn't perform ◦
- (3) Measuring frequency range from 30MHz to 1000MHz ◦
- (4) If the peak scan value lower limit more than 20dB, then this signal data does not how in table ◦

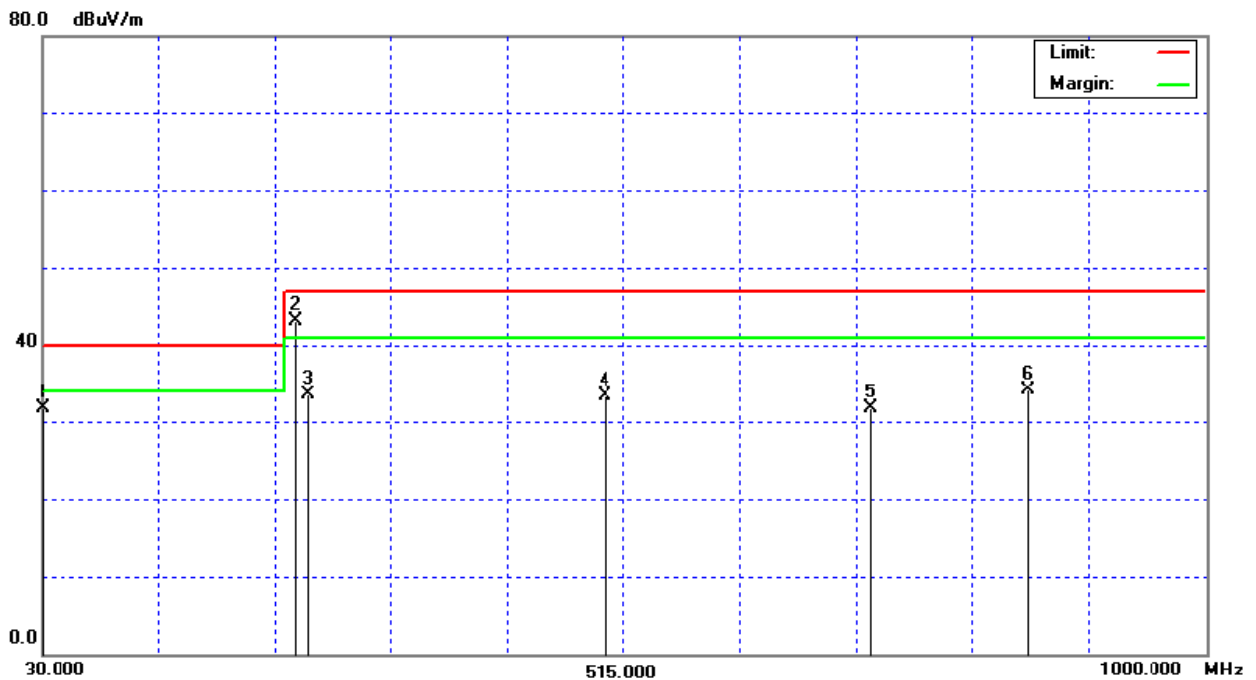



E.U.T :	SubCompact Board	Model Name :	GENE-9455-Bxxxxxx
Temperature :	25 °C	Relative Humidity :	75%
Test Voltage :	AC 120V/60Hz		
Test Mode :	D-SUB 1024*768/60Hz+VIDEO		

Freq. (MHz)	Ant. H/V	Reading(RA) (dBuV)	Corr.Factor(CF) (dB)	Measured(FS) (dBuV/m)	Limits(QP) (dBuV/m)	Margin (dB)	Note
240.01	H	42.18	-5.75	36.43	47.00	- 10.57	(QP)
257.58	H	42.35	-5.41	36.94	47.00	- 10.06	
365.15	H	41.45	-2.13	39.32	47.00	- 7.68	
480.13	H	36.69	0.67	37.36	47.00	- 9.64	
497.93	H	41.47	0.86	42.33	47.00	- 4.67	
720.04	H	30.66	5.16	35.82	47.00	- 11.18	(QP)

Remark :

- (1) Reading in which marked as QP or Peak means measurements by using are Quasi-Peak Mode or Peak Mode with Detector BW=120KHz ; SPA setting in RBW=120KHz, VBW =120KHz, Swp. Time = 0.3 sec./MHz ◦
- (2) All readings are Peak unless otherwise stated QP in column of 『Note』 . Peak denotes that the Peak reading compliance with the QP Limits and then QP Mode measurement didn't perform ◦
- (3) Measuring frequency range from 30MHz to 1000MHz ◦
- (4) If the peak scan value lower limit more than 20dB, then this signal data does not how in table ◦

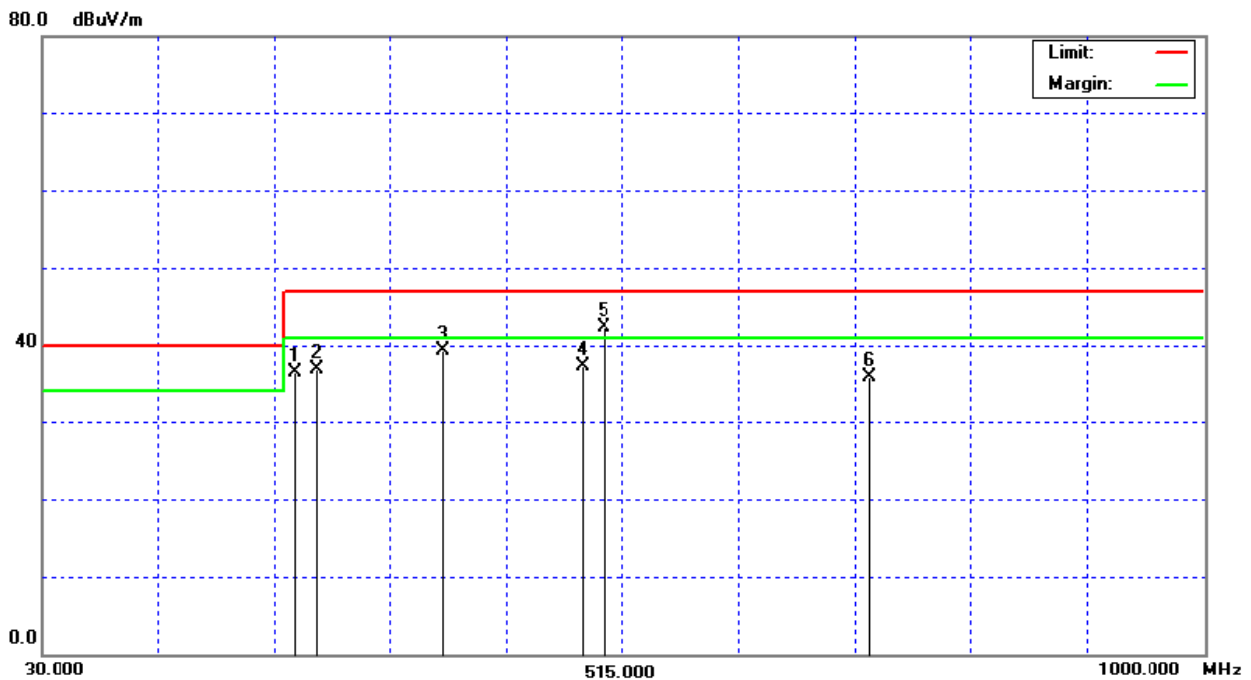



E.U.T :	SubCompact Board	Model Name :	GENE-9455-Bxxxxxx
Temperature :	25 °C	Relative Humidity :	75%
Test Voltage :	AC 120V/60Hz		
Test Mode :	D-SUB 1024*768/60Hz+VIDEO (OPEN CASE)		

Freq. (MHz)	Ant. H/V	Reading(RA) (dBuV)	Corr.Factor(CF) (dB)	Measured(FS) (dBuV/m)	Limits(QP) (dBuV/m)	Margin (dB)	Note
31.12	V	39.12	-6.61	32.51	40.00	- 7.49	
240.03	V	49.10	-5.75	43.35	47.00	- 3.65	
250.02	V	39.74	-5.44	34.30	47.00	- 12.70	
497.75	V	34.58	0.86	35.44	47.00	- 11.56	
720.08	V	29.45	5.16	34.61	47.00	- 12.39	(QP)
851.45	V	28.96	7.40	36.36	47.00	- 10.64	

Remark :

- (1) Reading in which marked as QP or Peak means measurements by using are Quasi-Peak Mode or Peak Mode with Detector BW=120KHz ; SPA setting in RBW=120KHz, VBW =120KHz, Swp. Time = 0.3 sec./MHz ◦
- (2) All readings are Peak unless otherwise stated QP in column of 『Note』 . Peak denotes that the Peak reading compliance with the QP Limits and then QP Mode measurement didn't perform ◦
- (3) Measuring frequency range from 30MHz to 1000MHz ◦
- (4) If the peak scan value lower limit more than 20dB, then this signal data does not how in table ◦

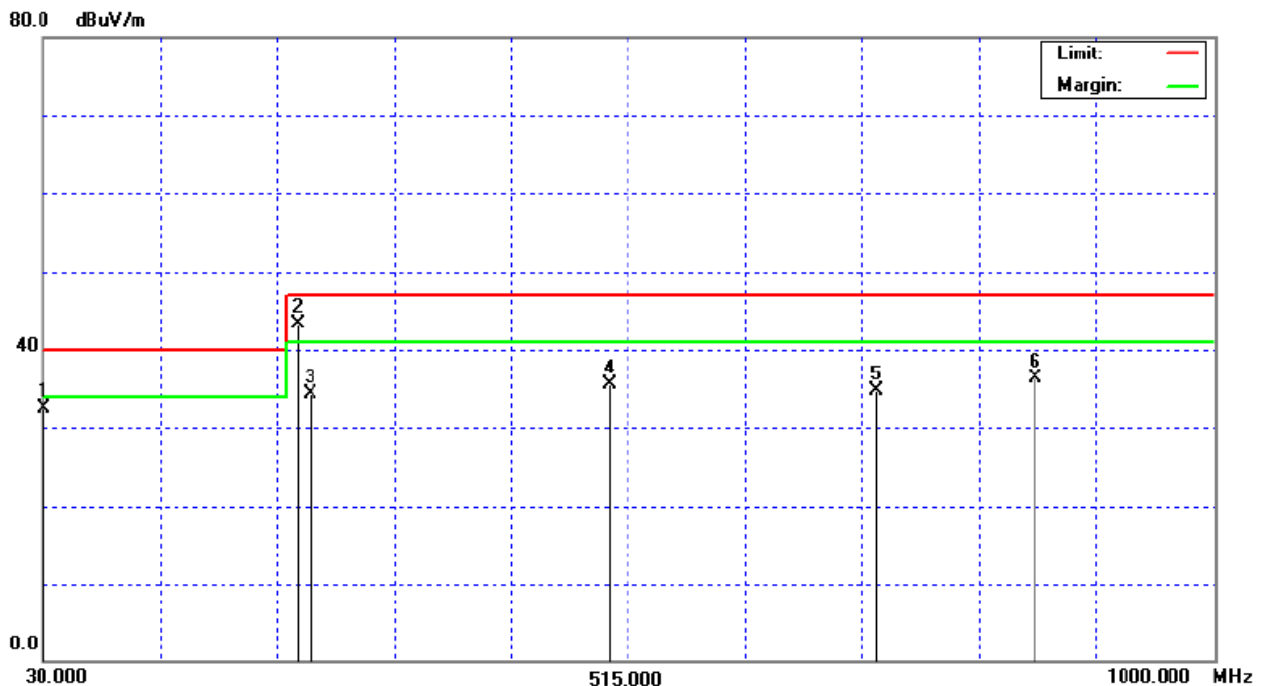



E.U.T :	SubCompact Board	Model Name :	GENE-9455-Bxxxxxx
Temperature :	25 °C	Relative Humidity :	75%
Test Voltage :	AC 120V/60Hz		
Test Mode :	D-SUB 1024*768/60Hz+VIDEO (OPEN CASE)		

Freq. (MHz)	Ant. H/V	Reading(RA) (dBuV)	Corr.Factor(CF) (dB)	Measured(FS) (dBuV/m)	Limits(QP) (dBuV/m)	Margin (dB)	Note
240.01	H	44.10	-5.75	38.35	47.00	- 8.65	(QP)
257.69	H	45.85	-5.41	40.44	47.00	- 6.56	
365.14	H	43.66	-2.13	41.53	47.00	- 5.47	
480.07	H	38.75	0.67	39.42	47.00	- 7.58	
497.72	H	42.01	0.86	42.87	47.00	- 4.13	
720.03	H	33.12	5.16	38.28	47.00	- 8.72	(QP)

Remark :

- (1) Reading in which marked as QP or Peak means measurements by using are Quasi-Peak Mode or Peak Mode with Detector BW=120KHz ; SPA setting in RBW=120KHz, VBW =120KHz, Swp. Time = 0.3 sec./MHz ◦
- (2) All readings are Peak unless otherwise stated QP in column of 『Note』 . Peak denotes that the Peak reading compliance with the QP Limits and then QP Mode measurement didn't perform ◦
- (3) Measuring frequency range from 30MHz to 1000MHz ◦
- (4) If the peak scan value lower limit more than 20dB, then this signal data does not how in table ◦

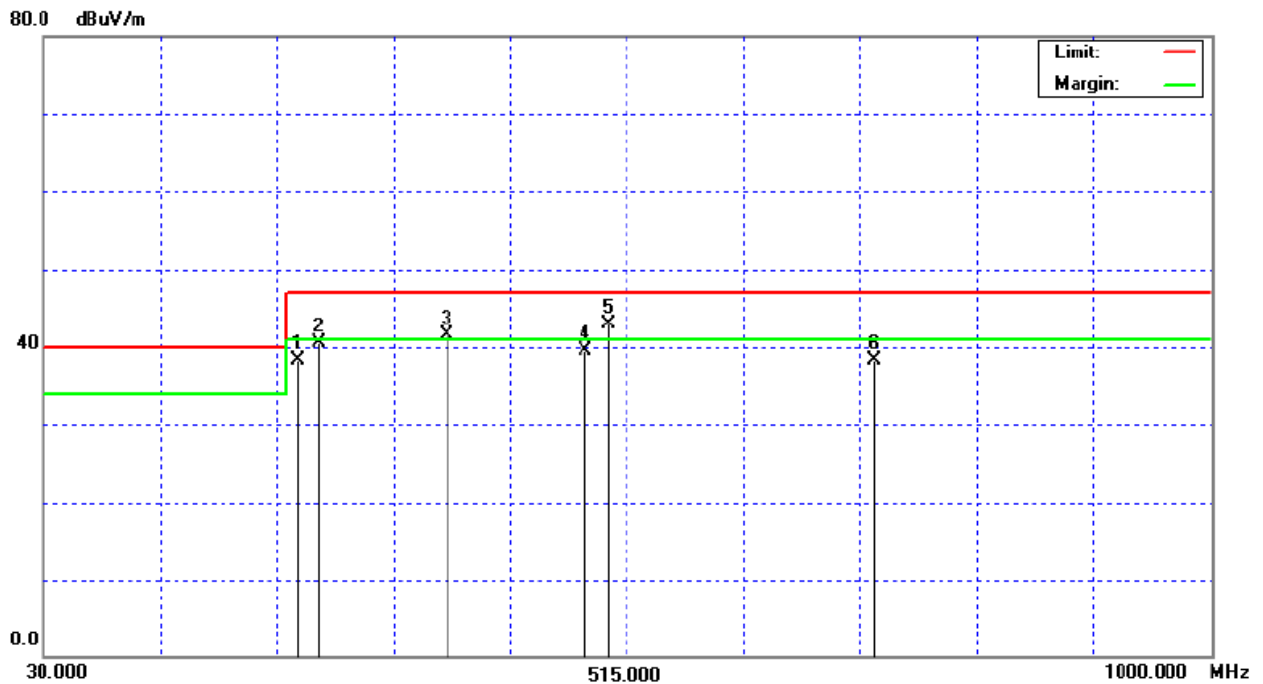



4.2.8 TEST RESULTS-ABOVE 1000MHZ

E.U.T :	SubCompact Board	Model Name :	GENE-9455-Bxxxxxx
Temperature :	26 °C	Relative Humidity :	57%
Test Voltage :	AC 120V/60Hz		
Test Mode :	D-SUB 1024*768/60Hz+VIDEO		

Freq. (MHz)	Ant.Pol. (H/V)	Reading(dBuV)		Ant./CF CF(dB)	Act.(dBuV/m)		Limit(dBuV/m)		Note
		Peak	AV		Peak	AV	Peak	AV	
1056.00	V	46.57	-	-7.60	38.97	-	80.00	60.00	
1224.00	V	41.72	-	-7.06	34.66	-	80.00	60.00	
1588.00	V	40.68	-	-6.00	34.68	-	80.00	60.00	
1882.00	V	40.57	-	-5.40	35.17	-	80.00	60.00	
2022.00	V	39.68	-	-5.05	34.63	-	80.00	60.00	
2316.00	V	41.86	-	-3.59	38.27	-	80.00	60.00	

Remark :

- (1) Reading in which marked as PK means measurements by using are Peak Mode with instrument setting in RBW= 1 MHz, VBW= 1 MHz, Swp. Time = Auto.  
Reading in which marked as AV means measurements by using are Average Mode with instrument setting in RBW= 1 MHz, VBW= 10 Hz, Swp. Time = Auto.
- (2) All readings are PK Mode value unless otherwise stated AVG in column of 『Note』 . If the PK Mode Measured value compliance with the PK Limits and lower than AVG Limits, the EUT shall be deemed to meet both PK & AVG Limits and then only PK Mode was measured, but AVG Mode didn't perform. In this case, a " \* " marked in AVG Mode column of Interference Voltage Measured.
- (3) Measuring frequency range above 1000MHz.

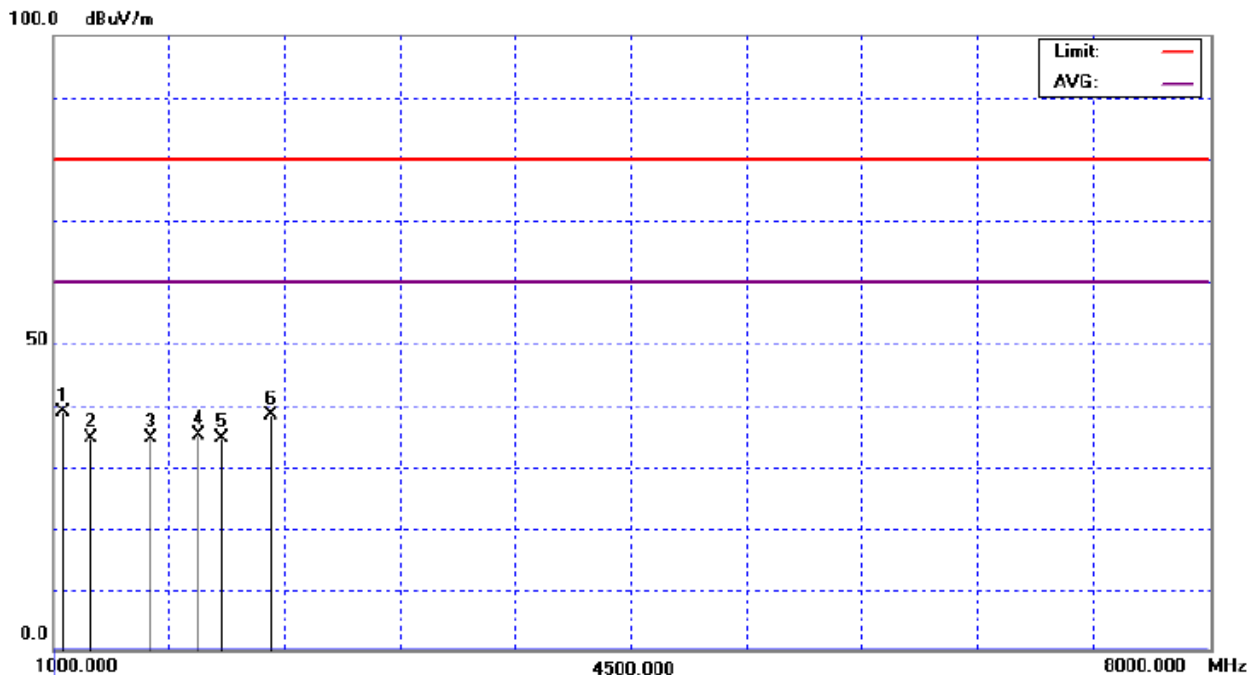



E.U.T :	SubCompact Board	Model Name :	GENE-9455-Bxxxxxx
Temperature :	26 °C	Relative Humidity :	57%
Test Voltage :	AC 120V/60Hz		
Test Mode :	D-SUB 1024*768/60Hz+VIDEO		

Freq. (MHz)	Ant.Pol. (H/V)	Reading(dBuV)		Ant./CF CF(dB)	Act.(dBuV/m)		Limit(dBuV/m)		Note
		Peak	AV		Peak	AV	Peak	AV	
1056.00	H	45.89	-	-7.60	38.29	-	80.00	60.00	
1322.00	H	40.89	-	-6.75	34.14	-	80.00	60.00	
1672.00	H	39.70	-	-5.83	33.87	-	80.00	60.00	
1812.00	H	39.01	-	-5.54	33.47	-	80.00	60.00	
2092.00	H	38.88	-	-4.70	34.18	-	80.00	60.00	
2414.00	H	40.55	-	-3.11	37.44	-	80.00	60.00	

Remark :

- (1) Reading in which marked as PK means measurements by using are Peak Mode with instrument setting in RBW= 1 MHz, VBW= 1 MHz, Swp. Time = Auto.  
Reading in which marked as AV means measurements by using are Average Mode with instrument setting in RBW= 1 MHz, VBW= 10 Hz, Swp. Time = Auto.
- (2) All readings are PK Mode value unless otherwise stated AVG in column of 『Note』 . If the PK Mode Measured value compliance with the PK Limits and lower than AVG Limits, the EUT shall be deemed to meet both PK & AVG Limits and then only PK Mode was measured, but AVG Mode didn't perform. In this case, a " \* " marked in AVG Mode column of Interference Voltage Measured.
- (3) Measuring frequency range above 1000MHz.

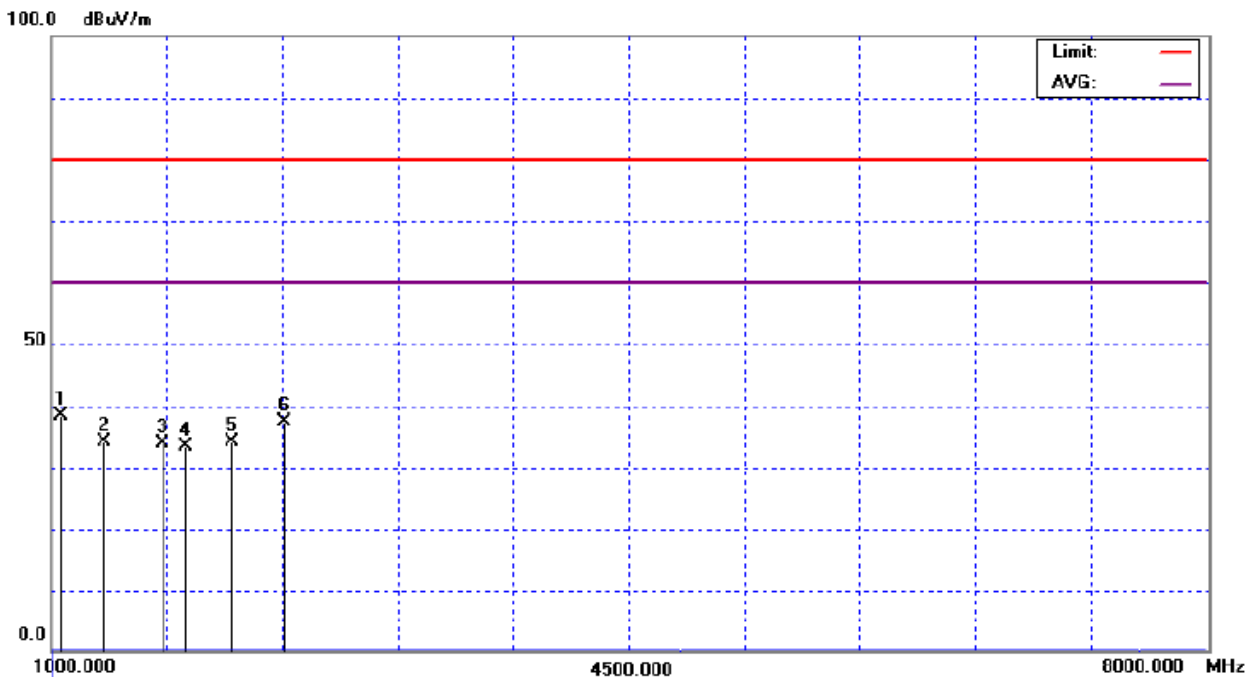





E.U.T :	SubCompact Board	Model Name :	GENE-9455-Bxxxxxx
Temperature :	26 °C	Relative Humidity :	57%
Test Voltage :	AC 120V/60Hz		
Test Mode :	D-SUB 1024*768/60Hz+VIDEO (OPEN CASE)		

Freq. (MHz)	Ant.Pol. (H/V)	Reading(dBuV)		Ant./CF CF(dB)	Act.(dBuV/m)		Limit(dBuV/m)		Note
		Peak	AV		Peak	AV	Peak	AV	
1056.00	V	48.37	-	-7.60	40.77	-	80.00	60.00	
1224.00	V	44.17	-	-7.06	37.11	-	80.00	60.00	
1589.00	V	42.44	-	-6.00	36.44	-	80.00	60.00	
1885.00	V	43.16	-	-5.39	37.77	-	80.00	60.00	
2023.00	V	42.73	-	-5.04	37.69	-	80.00	60.00	
2315.00	V	42.99	-	-3.59	39.40	-	80.00	60.00	

Remark :

- (1) Reading in which marked as PK means measurements by using are Peak Mode with instrument setting in RBW= 1 MHz, VBW= 1 MHz, Swp. Time = Auto.  
Reading in which marked as AV means measurements by using are Average Mode with instrument setting in RBW= 1 MHz, VBW= 10 Hz, Swp. Time = Auto.
- (2) All readings are PK Mode value unless otherwise stated AVG in column of 『Note』 . If the PK Mode Measured value compliance with the PK Limits and lower than AVG Limits, the EUT shall be deemed to meet both PK & AVG Limits and then only PK Mode was measured, but AVG Mode didn't perform. In this case, a " \* " marked in AVG Mode column of Interference Voltage Measured.
- (3) Measuring frequency range above 1000MHz.

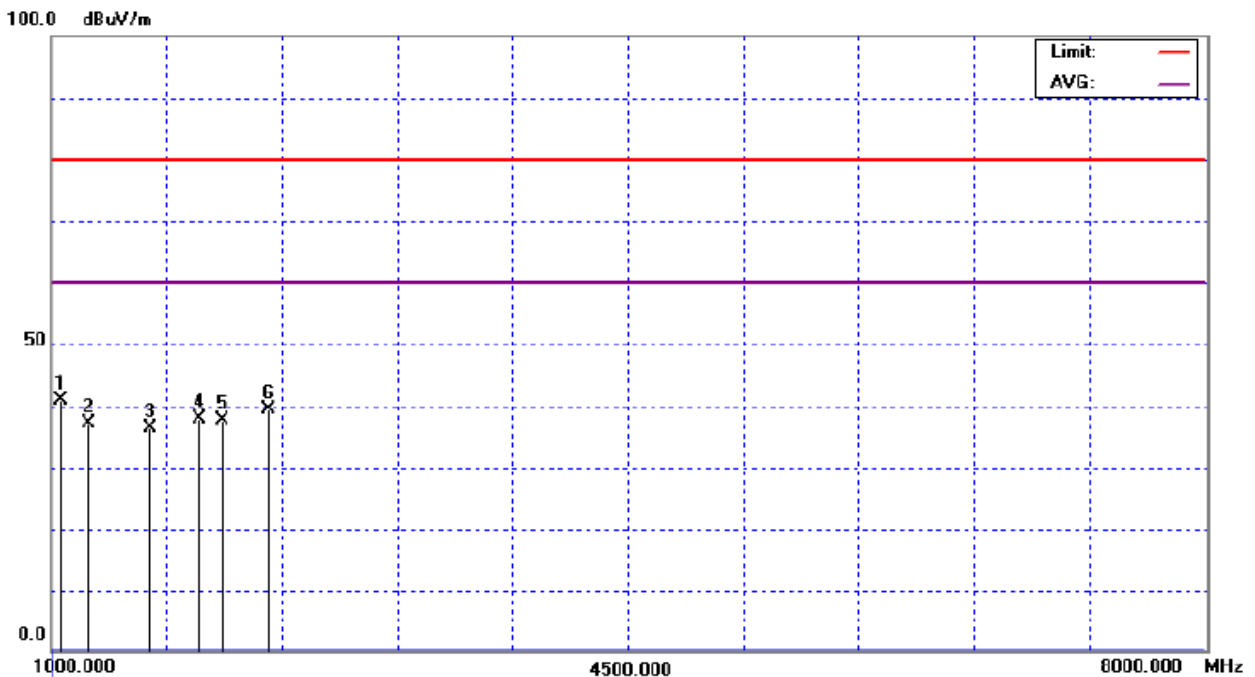



E.U.T :	SubCompact Board	Model Name :	GENE-9455-Bxxxxxx
Temperature :	26 °C	Relative Humidity :	57%
Test Voltage :	AC 120V/60Hz		
Test Mode :	D-SUB 1024*768/60Hz+VIDEO (OPEN CASE)		

Freq. (MHz)	Ant.Pol. (H/V)	Reading(dBuV)		Ant./CF CF(dB)	Act.(dBuV/m)		Limit(dBuV/m)		Note
		Peak	AV		Peak	AV	Peak	AV	
1056.00	H	47.57	-	-7.60	39.97	-	80.00	60.00	
1323.00	H	42.47	-	-6.75	35.72	-	80.00	60.00	
1674.00	H	44.20	-	-5.83	38.37	-	80.00	60.00	
1812.00	H	42.63	-	-5.54	37.09	-	80.00	60.00	
2093.00	H	42.10	-	-4.70	37.40	-	80.00	60.00	
2415.00	H	42.41	-	-3.10	39.31	-	80.00	60.00	

Remark :

- (1) Reading in which marked as PK means measurements by using are Peak Mode with instrument setting in RBW= 1 MHz, VBW= 1 MHz, Swp. Time = Auto.  
Reading in which marked as AV means measurements by using are Average Mode with instrument setting in RBW= 1 MHz, VBW= 10 Hz, Swp. Time = Auto.
- (2) All readings are PK Mode value unless otherwise stated AVG in column of 『Note』 . If the PK Mode Measured value compliance with the PK Limits and lower than AVG Limits, the EUT shall be deemed to meet both PK & AVG Limits and then only PK Mode was measured, but AVG Mode didn't perform. In this case, a " \* " marked in AVG Mode column of Interference Voltage Measured.
- (3) Measuring frequency range above 1000MHz.

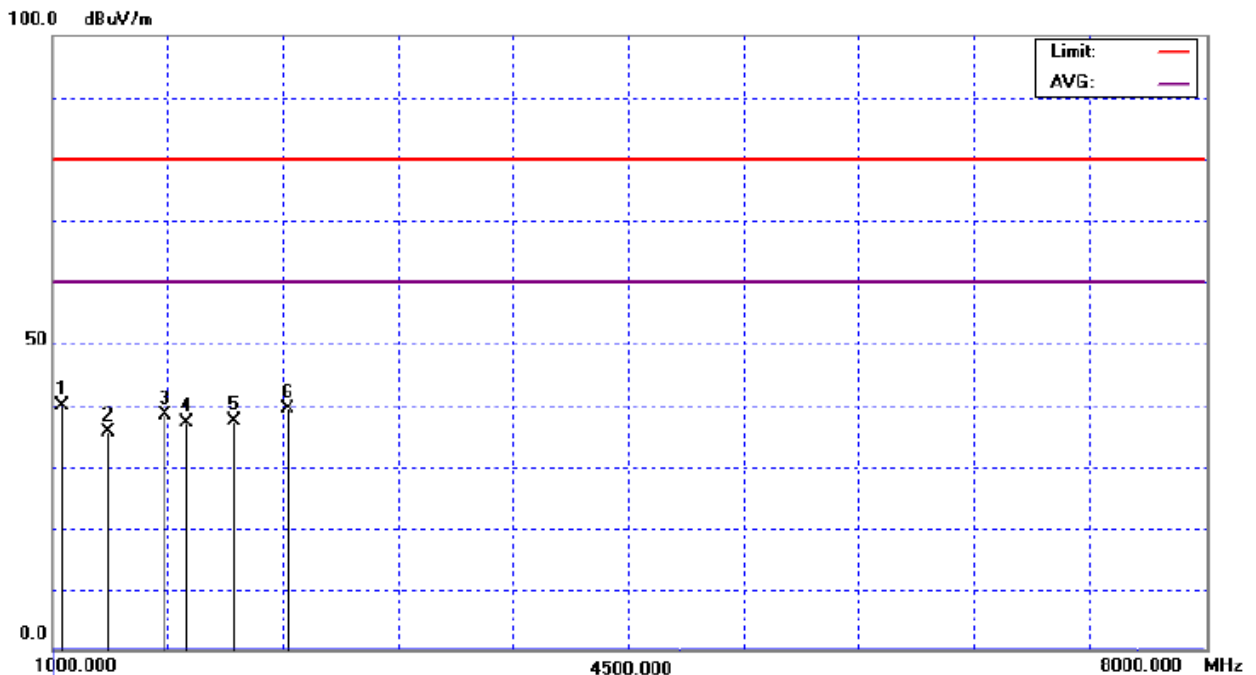

5. EUT TEST PHOTO

Conducted Measurement Photos



**Radiated Measurement Photos**





**Radiated Measurement Photos**

**OPEN CASE**

