

# FCC 47 CFR PART 15 SUBPART B TEST REPORT

for

**ETX Board**

**MODEL: ETX-945GSE-xxxxxx**

Test Report Number:  
91013201-F

Issued to:

**AAEON Technology Inc.**

**5F, No.135, Lane 235, Pao Chiao Rd., Hsin-Tien City,  
Taipei, Taiwan, R.O.C.**

Issued by:

**Compliance Certification Services Inc.**

**Sindian BU.**

**No.163-1, Jhongsheng Rd., Sindian City,  
Taipei County 23151, Taiwan**

**TEL: 886-2-22170894**

**FAX: 886-2-22171029**

**Issued Date: October 26, 2009**



**Note:** This report shall not be reproduced except in full, without the written approval of Compliance Certification Services Inc. This document may be altered or revised by Compliance Certification Services Inc. personnel only, and shall be noted in the revision section of the document. The client should not use it to claim product endorsement by TAF, A2LA, NIST or any government agencies. The test results in the report only apply to the tested sample.



**Revision History**

Rev.	Issue Date	Revisions	Effect Page	Revised By
00	October 26, 2009	Initial Issue	ALL	Joy Hsiao



TABLE OF CONTENTS

**1 TEST RESULT CERTIFICATION ..... 4**

**2 EUT DESCRIPTION..... 5**

**3 TEST METHODOLOGY..... 6**

    3.1. DECISION OF FINAL TEST MODE..... 6

    3.2. EUT SYSTEM OPERATION ..... 6

**4 SETUP OF EQUIPMENT UNDER TEST ..... 7**

    4.1. DESCRIPTION OF SUPPORT UNITS ..... 7

    4.2. CONFIGURATION OF SYSTEM UNDER TEST ..... 8

**5 FACILITIES AND ACCREDITATIONS ..... 9**

    5.1. FACILITIES ..... 9

    5.2. ACCREDITATIONS..... 9

    5.3. MEASUREMENT UNCERTAINTY..... 9

**6 CONDUCTED EMISSION MEASUREMENT ..... 10**

    6.1. LIMITS OF CONDUCTED EMISSION MEASUREMENT ..... 10

    6.2. TEST INSTRUMENTS ..... 10

    6.3. TEST PROCEDURES ..... 11

    6.4. TEST SETUP ..... 12

    6.5. DATA SAMPLE ..... 12

    6.6. TEST RESULTS..... 13

**7 RADIATED EMISSION MEASUREMENT ..... 14**

    7.1. LIMITS OF RADIATED EMISSION MEASUREMENT ..... 14

    7.2. TEST INSTRUMENTS ..... 15

    7.3. TEST PROCEDURES..... 16

    7.4. TEST SETUP ..... 17

    7.5. DATA SAMPLE ..... 18

    7.6. TEST RESULTS..... 19

**8 PHOTOGRAPHS OF THE TEST CONFIGURATION..... 21**



# 1 TEST RESULT CERTIFICATION

<b>Product:</b>	ETX Board
<b>Model:</b>	ETX-945GSE-xxxxxx(Where x is 0-9 , A-Z , -or blank) for marketing purpose
<b>Brand:</b>	AAEON
<b>Applicant:</b>	<b>AAEON Technology Inc.</b> 5F, No.135, Lane 235, Pao Chiao Rd., Hsin-Tien City, Taipei, Taiwan, R.O.C.
<b>Manufacturer:</b>	<b>AAEON Technology Inc.</b> 5F, No.135, Lane 235, Pao Chiao Rd., Hsin-Tien City, Taipei, Taiwan, R.O.C.
<b>Tested:</b>	October 13, 2009 & October 20, 2009



EMISSION			
Standard	Item	Result	Remarks
FCC 47 CFR Part 15 Subpart B, ICES-003 Issue 4 ANSI C63.4-2003	Conducted (Power Port)	PASS	Meet Class A limit
	Radiated	PASS	Meet Class A limit

- Note:
1. The statements of test result on the above are decided by the request of test standard only; the measurement uncertainties are not factored into this compliance determination.
  2. The information of measurement uncertainty is available upon the customer's request.

Deviation from Applicable Standard
None

The above equipment has been tested by Compliance Certification Services Inc., and found compliance with the requirements set forth in the technical standards mentioned above. The results of testing in this report apply only to the product/system, which was tested. Other similar equipment will not necessarily produce the same results due to production tolerance and measurement uncertainties.

Approved by:

  
  
 \_\_\_\_\_  
 Vince Chiang  
 Assistant Manager

Reviewed by:

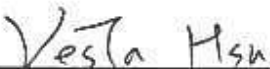
  
 \_\_\_\_\_  
 Vesta Hsu  
 Supervisor of report document dept.



## 2 EUT DESCRIPTION

<b>Product</b>	ETX Board
<b>Brand Name</b>	AAEON
<b>Model</b>	ETX-945GSE-xxxxxx(Where x is 0-9 , A-Z , -or blank) for marketing purpose
<b>Applicant</b>	AAEON Technology Inc.
<b>Housing material</b>	N/A
<b>Identify Number</b>	91013201
<b>Received Date</b>	October 13, 2009
<b>EUT Power Rating</b>	5VDC from Host PC
<b>AC Power During Test</b>	120VAC / 60Hz to Host PC Power Supply
<b>OSC/Clock Frequencies</b>	14.31818MHz; 25MHz; 32.768kHz; 24.576MHz

### I/O PORT

I/O PORT TYPES	Q'TY	TESTED WITH
1. PIO Port	1	1
2. SIO Port	4	4
3. PS/2 Keyboard Port	1	1
4. PS/2 Mouse Port	1	1
5. VGA Port	1	1
6. Audio In Port	1	1
7. Microphone Port	1	1
8. Earphone Port	1	1
9. USB Port	4	4
10. LAN Port	1	1

**Note:** Client consigns only one model sample to test (Model Number: ETX-945GSE).

### 3 TEST METHODOLOGY

#### 3.1. DECISION OF FINAL TEST MODE

The EUT was tested together with the above additional components, and a configuration, which produced the worst emission levels, was selected and recorded in this report.

The test configuration/ modes are as the following:

**Conduction Mode:**

1	NORMAL MODE
---	-------------

**Radiation Modes:**

1	NORMAL MODE
	NORMAL MODE / 1-8GHz

**Conduction:** Mode 1

**Radiation:** Mode 1

#### 3.2. EUT SYSTEM OPERATION

1. Windows XP boots system.
2. Run Emctest.exe to activate all peripherals and display “H” pattern on monitor screen.
3. Run Winemc.exe and choose “E:/ & F:/ & G:/ & H:” to test USB 2.0 port.
4. Run Winemc.exe and choose media player to play music.
5. Press the start menu, select executive and type ping 192.168.0.2 –t (EUT), ping 192.168.0.1 –t (Server Notebook).

**Note:** Test program is self-repeating throughout the test.

## 4 SETUP OF EQUIPMENT UNDER TEST

### 4.1. DESCRIPTION OF SUPPORT UNITS

The EUT has been tested as an independent unit together with other necessary accessories or support units. The following support units or accessories were used to form a representative test configuration during the tests.

#### Host PC Devices:

No.	Equipment	Model No.	Trade Name
1	CPU (1.6GHz)	Atom 1.6GHz	Intel
2	Memory (512MB / DDR2-667)	E5108AE-5C-E	ELPIDA
3	Power Supply	ST-300HLP	Seventeam
4	SATA HDD (80GB)	WD800AAJS	WD
5	Carrier Board	ECB-902M	AAEON

#### Peripherals Devices:

No.	Equipment	Model No.	Serial No.	FCC ID / BSMI ID	Trade Name	Data Cable	Power Cord
1-4	USB 2.0 HDD	F12-U	N/A	BSMI ID: 4912A002	TeraSys	Shielded, 1.8m	N/A
5	PS/2 Mouse	M-SBF69	HCA54301042	DoC BSMI: R41126	Logitech	Shielded, 1.8m	N/A
6	PS/2 Keyboard	Y-SJ17	867247-0121	DoC BSMI: T51160	Logitech	Shielded, 1.8m	N/A
7	Player	RQ-L11LT	N/A	BSMI ID: 3912A162	Panasonic	Unshielded, 1.8m	N/A
8	Earphone & Microphone	M071KC	443029438	DoC BSMI: R41108	DELL	Unshielded, 1.8m	N/A
9	Printer	C20SX	N/A	BSMI ID: 3902E004	EPSON	Shielded, 1.8m	Unshielded, 1.8m
10	Monitor	710V	GS17H9NXA0585 3A	DoC BSMI: R33475	SAMSUNG	Shielded, 1.8m with two cores	Unshielded, 1.8m
11-14	Modem	5JEG4033MKO	N/A	5RJTAI-35500-M5- E	TOP- SOLUTION	Shielded, 1.8m	Unshielded, 1.8m
15	Server Notebook	PP05L	2464936188	DoC BSMI: R33002	DELL	Unshielded, 20m	Unshielded, 1.8m with a core

#### Note:

- 1) All the equipment/cables were placed in the worst-case configuration to maximize the emission during the test.
- 2) Grounding was established in accordance with the manufacturer's requirements and conditions for the intended use.

## 4.2. CONFIGURATION OF SYSTEM UNDER TEST

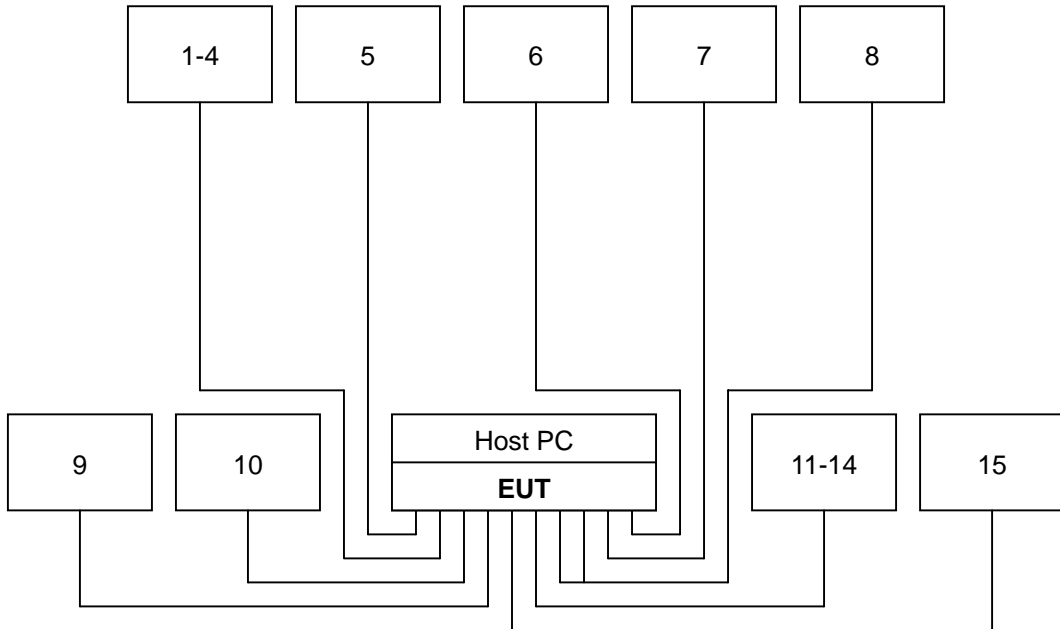



## 5 FACILITIES AND ACCREDITATIONS

### 5.1. FACILITIES

All measurement facilities (exclude facilities of measurement radiated frequency above 1GHz) used to collect the measurement data are located at CCS Taiwan Sindian BU. at No.163-1, Jhongsheng Rd., Sindian City, Taipei County 23151, Taiwan.

The measurement facilities of radiated frequency rang above 1GHz are located at CCS Taiwan Linkou BU. at No.81-1, Lane 210, Bade 2nd Rd., Lujhu Township, Taoyuan County 33841, Taiwan Taoyuan Hsien, Taiwan.

The sites are constructed in conformance with the requirements of ANSI C63.4 and CISPR Publication 22. All receiving equipment conforms to CISPR 16-1-1, CISPR 16-1-2, CISPR 16-1-3, CISPR 16-1-4 and CISPR 16-1-5.

### 5.2. ACCREDITATIONS

Our laboratories are accredited and approved by the following accreditation body according to ISO/IEC 17025.

<b>Taiwan</b>	TAF
<b>USA</b>	A2LA

The measuring facility of laboratories has been authorized or registered by the following approval agencies.

<b>Canada</b>	Industry Canada
<b>Germany</b>	TUV Rheinland
<b>Japan</b>	VCCI
<b>Taiwan</b>	BSMI
<b>USA</b>	FCC

Copies of granted accreditation certificates are available for downloading from our web site, <http://www.ccsrf.com>

### 5.3. MEASUREMENT UNCERTAINTY

Where relevant, the following measurement uncertainty levels have been estimated for tests performed on the EUT as specified in CISPR 16-4-2:

Measurement	Frequency	Uncertainty
Conducted emissions	0.15MHz ~ 30MHz	± 1.7376
Radiated emissions	30MHz ~ 200MHz	± 3.8792
	200MHz ~ 1000MHz	± 3.8914

This uncertainty represents an expanded uncertainty expressed at approximately the 95% confidence level using a coverage factor of k=2.

Consistent with industry standard (e.g. CISPR 22: 2005, clause 11, Measurement Uncertainty) determining compliance with the limits shall be base on the results of the compliance measurement. Consequently the measure emissions being less than the maximum allowed emission result in this be a compliant test or passing test.

The acceptable measurement uncertainty value without requiring revision of the compliance statement is base on conducted and radiated emissions being less than  $U_{CISPR}$  which is 3.6dB and 5.2dB respectively. CCS values (called  $U_{Lab}$  in CISPR 16-4-2) is less than  $U_{CISPR}$  as shown in the table above. Therefore, MU need not be considered for compliance.



## 6 CONDUCTED EMISSION MEASUREMENT

### 6.1. LIMITS OF CONDUCTED EMISSION MEASUREMENT

FREQUENCY (MHz)	Class A (dBuV)		Class B (dBuV)	
	Quasi-peak	Average	Quasi-peak	Average
0.15 - 0.5	79	66	66 - 56	56 - 46
0.50 - 5.0	73	60	56	46
5.0 - 30.0	73	60	60	50

**Note:**

1. The lower limit shall apply at the transition frequencies.
2. The limit decreases in line with the logarithm of the frequency in the range 0.15 to 0.50 MHz.
3. All emanations from a class A/B digital device or system, including any network of conductors and apparatus connected thereto, shall not exceed the level of field strengths specified above.

### 6.2. TEST INSTRUMENTS

Conducted Emission room # A				
Name of Equipment	Manufacturer	Model	Serial Number	Calibration Due
TEST RECEIVER	R&S	ESHS20	840455/006	02/12/2010
LISN (EUT)	SCHWARZBECK	NSLK 8127	8127382	12/09/2009
LISN	SOLAR	8012-50-R-24-BNC	8305114	12/09/2009
BNC CABLE	MIYAZAKI	5D-FB	BNC A4	05/11/2010
THERMO-HYGRO METER	TECPEL	DTM-303	No.7	11/24/2009
Test S/W	EMI 32.exe			

**Note:**

1. The calibration interval of the above test instruments is 12 months and the calibrations are traceable to NML/ROC and NIST/USA.
2. N.C.R = No Calibration Request.

### **6.3. TEST PROCEDURES** (please refer to measurement standard or CCS SOP PA-031)

#### **Procedure of Preliminary Test**

- The EUT and support equipment, if needed, were set up as per the test configuration to simulate typical usage per the user's manual. When the EUT is a tabletop system, a wooden table with a height of 0.8 meters is used and is placed on the ground plane as per ANSI C63.4 (see Test Facility for the dimensions of the ground plane used). When the EUT is a floor standing equipment, it is placed on the ground plane, which has a 12 mm non-conductive covering to insulate the EUT from the ground plane.
- All I/O cables were positioned to simulate typical actual usage as per ANSI C63.4.
- The test equipment EUT installed by AC 120VAC/60Hz main power, through a Line Impedance Stabilization Network (LISN), which was supplied power source and was grounded to the ground plane.
- All support equipment power by from a second LISN.
- The test program of the EUT was started. Emissions were measured on each current carrying line of the EUT using an EMI Test Receiver connected to the LISN powering the EUT.
- The Receiver scanned from 150kHz to 30MHz for emissions in each of the test modes.
- During the above scans, the emissions were maximized by cable manipulation.
- The test mode(s) described in Item 3.1 were scanned during the preliminary test.
- After the preliminary scan, we found the test mode described in Item 3.1 producing the highest emission level.
- The worst configuration of EUT and cable of the above highest emission level were recorded for reference of the final test.

#### **Procedure of Final Test**

- EUT and support equipment were set up on the test bench as per the configuration with highest emission level in the preliminary test.
- A scan was taken on both power lines, Line 1 and Line 2, recording at least the six highest emissions. Emission frequency and amplitude were recorded into a computer in which correction factors were used to calculate the emission level and compare reading to the applicable limit.
- The test data of the worst-case condition(s) was recorded.

### 6.4. TEST SETUP

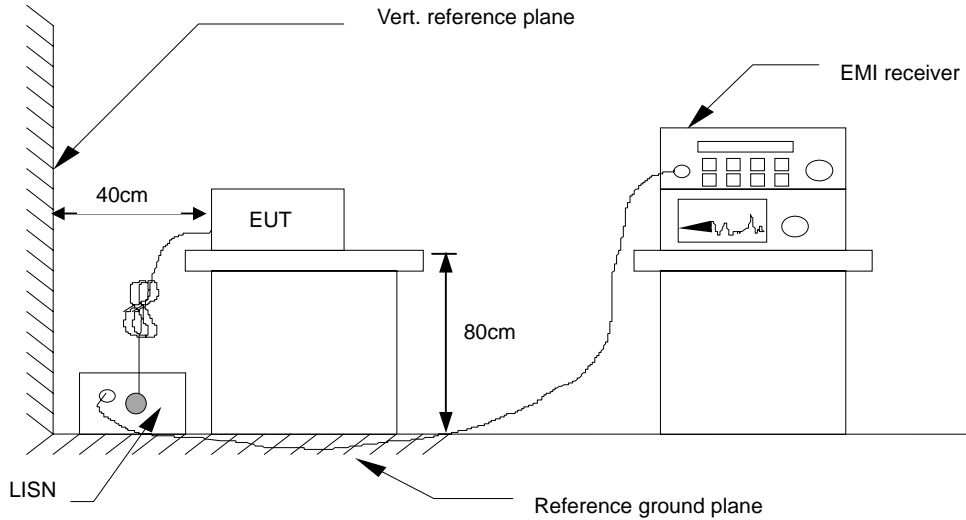

- For the actual test configuration, please refer to the related item – Photographs of the Test Configuration.

### 6.5. DATA SAMPLE

Freq. (MHz)	Read Level (dBuV)	Factor (dB)	Level (dBuV)	Limit Line (dBuV)	Over Limit (dB)	Remark (P/Q/A)	Line (L1/L2)
x.xx	42.95	0.55	43.50	73	-29.50	Q	L1

- Freq. = Emission frequency in MHz
- Read Level = Uncorrected Analyzer/Receiver reading
- Factor = Insertion loss of LISN + Cable Loss
- Level = Read Level + Factor
- Limit Line = Limit stated in standard
- Over Limit = Reading in reference to limit
- P = Peak Reading
- Q = Quasi-peak Reading
- A = Average Reading
- L1 = Hot side
- L2 = Neutral side

#### Calculation Formula

Over Limit (dB) = Level (dBuV) – Limit Line (dBuV)



**6.6. TEST RESULTS**

<b>Model No.</b>	ETX-945GSE	<b>6dB Bandwidth</b>	10 kHz
<b>Environmental Conditions</b>	24deg.C, 58% RH, 1010hPa	<b>Test Mode</b>	Mode 1
<b>Tested by</b>	Benson Yang		

(The chart below shows the highest readings taken from the final data.)

<b>Six Highest Conducted Emission Readings</b>							
<b>Frequency Range Investigated</b>				<b>150 kHz to 30 MHz</b>			
<b>Freq. (MHz)</b>	<b>Read Level (dBuV)</b>	<b>Factor (dB)</b>	<b>Level (dBuV)</b>	<b>Limit Line (dBuV)</b>	<b>Over Limit (dB)</b>	<b>Remark (P/Q/A)</b>	<b>Line (L1/L2)</b>
<b>9.011</b>	<b>29.94</b>	<b>0.58</b>	<b>30.52</b>	<b>73.00</b>	<b>-42.48</b>	<b>P</b>	<b>L1</b>
<b>19.326</b>	<b>35.18</b>	<b>1.17</b>	<b>36.35</b>	<b>73.00</b>	<b>-36.65</b>	<b>P</b>	<b>L1</b>
<b>0.598</b>	<b>30.56</b>	<b>0.09</b>	<b>30.65</b>	<b>73.00</b>	<b>-42.35</b>	<b>P</b>	<b>L2</b>
<b>4.384</b>	<b>30.56</b>	<b>0.25</b>	<b>30.81</b>	<b>73.00</b>	<b>-42.19</b>	<b>P</b>	<b>L2</b>
<b>13.479</b>	<b>32.16</b>	<b>0.66</b>	<b>32.82</b>	<b>73.00</b>	<b>-40.18</b>	<b>P</b>	<b>L2</b>
<b>19.845</b>	<b>38.07</b>	<b>0.96</b>	<b>39.03</b>	<b>73.00</b>	<b>-33.97</b>	<b>P</b>	<b>L2</b>

**Note:**

1. L1 = Line One (Live Line) / L2 = Line Two (Neutral Line).
2. The emission level was or more than 2dB below the Average limit, so no re-check anymore.

## 7 RADIATED EMISSION MEASUREMENT

### 7.1. LIMITS OF RADIATED EMISSION MEASUREMENT

#### Below 1GHz

FREQUENCY (MHz)	dBuV/m (At 10m)	
	Class A	Class B
30 ~ 230	40	30
230 ~ 1000	47	37

**Note:**

1. The lower limit shall apply at the transition frequencies.
2. Emission level (dBuV/m) = 20 log Emission level (uV/m).

#### Above 1GHz

Frequency (MHz)	Class A (dBuV/m) (At 10m)		Class B (dBuV/m) (At 3m)	
	Average	Peak	Average	Peak
Above 1000	60	80	54	74

**Note:**

1. The lower limit shall apply at the transition frequencies.
2. Emission level (dBuV/m) = 20 log Emission level (uV/m).

According to FCC Part 15.33 (b), for an unintentional radiator, including a digital device, the spectrum shall be investigated from the lowest radio frequency signal generated or used in the device, without going below the lowest frequency for which a radiated emission limit is specified, up to the frequency shown in the following table:

Highest frequency generated or used in the device or on which the device operates or tunes (MHz)	Upper frequency of measurement range (MHz)
Below 1.75	30
1.75-108	1000
108-500	2000
500-1000	5000
Above 1000	5 <sup>th</sup> harmonic of the highest frequency or 40GHz, whichever is lower



7.2. TEST INSTRUMENTS

Open Area Test Site # I				
Name of Equipment	Manufacturer	Model	Serial Number	Calibration Due
MEASURE RECEIVER	SCHAFFNER	SCR3501	338	07/07/2010
SPECTRUM ANALYZER	ADVANTEST	R3132	120900008	No Calibration Required
ANTENNA	SCHAFFNER	CBL 6112B	2809	09/06/2010
AMPLIFIER	SCHAFFNER	CPA9231A	3626	10/11/2010
CABLE	BELDEN	9913	N-TYPE #12	02/22/2010
THERMO-HYGRO METER	TECPEL	DTM-303	090639	05/24/2010
Test S/W	Lab VIEW 7.1			
Above 1GHz Used				
Spectrum Analyzer	Agilent	E4407B	MY44212679	12/28/2009
Bilog Antenna	SCHWAZBECK	VULB9160	3084	09/11/2010
EMI Test Receiver	SCHAFFNER	SCR 3501	436	01/21/2010
Pre-Amplifier	HP	8447D	2944A06530	12/31/2009
Turn Table	CCS	CC-T-1F	N/A	N.C.R
Antenna Tower	CCS	CC-A-1F	N/A	N.C.R
Controller	CCS	CC-C-1F	N/A	N.C.R
Site NSA	SIDT EUROPE	9x6x6	N/A	05/15/2010
Test S/W	CCS-3A1RE			

Note:

1. The calibration interval of the above test instruments is 12 months and the calibrations are traceable to NML/ROC and NIST/USA.
2. N.C.R = No Calibration Request.

**7.3. TEST PROCEDURES** (please refer to measurement standard or CCS SOP PA-031)**Procedure of Preliminary Test**

- The equipment was set up as per the test configuration to simulate typical usage per the user's manual. When the EUT is a tabletop system, a wooden turntable with a height of 0.8 meters is used which is placed on the ground plane. When the EUT is a floor standing equipment, it is placed on the ground plane which has a 12 mm non-conductive covering to insulate the EUT from the ground plane.
- Support equipment, if needed, was placed as per ANSI C63.4.
- All I/O cables were positioned to simulate typical usage as per ANSI C63.4.
- The EUT received AC 120VAC/60Hz power source from the outlet socket under the turntable. All support equipment power received from another socket under the turntable.
- The antenna was placed at 3 or 10 meter away from the EUT as stated in ANSI C63.4. The antenna connected to the Spectrum Analyzer via a cable and at times a pre-amplifier would be used.
- The Analyzer / Receiver quickly scanned from 30MHz to 40GHz. The EUT test program was started. Emissions were scanned and measured rotating the EUT to 360 degrees and positioning the antenna 1 to 4 meters above the ground plane, in both the vertical and the horizontal polarization, to maximize the emission reading level.
- The test mode(s) described in Item 3.1 were scanned during the preliminary test:
- After the preliminary scan, we found the test mode described in Item 3.1 producing the highest emission level.
- The worst configuration of EUT and cable of the above highest emission level were recorded for reference of the final test.



**Procedure of Final Test**

- EUT and support equipment were set up on the turntable as per the configuration with highest emission level in the preliminary test.
- The Analyzer / Receiver scanned from 30MHz to 40GHz. Emissions were scanned and measured rotating the EUT to 360 degrees, varying cable placement and positioning the antenna 1 to 4 meters above the ground plane, in both the vertical and the horizontal polarization, to maximize the emission reading level.
- Recording at least the six highest emissions. Emission frequency, amplitude, antenna position, polarization and turntable position were recorded into a computer in which correction factors were used to calculate the emission level and compare reading to the applicable limit. Below 1GHz the Q.P. reading and above 1GHz the Peak and Average reading are presented.
- The test data of the worst-case condition(s) was recorded.

**7.4. TEST SETUP**

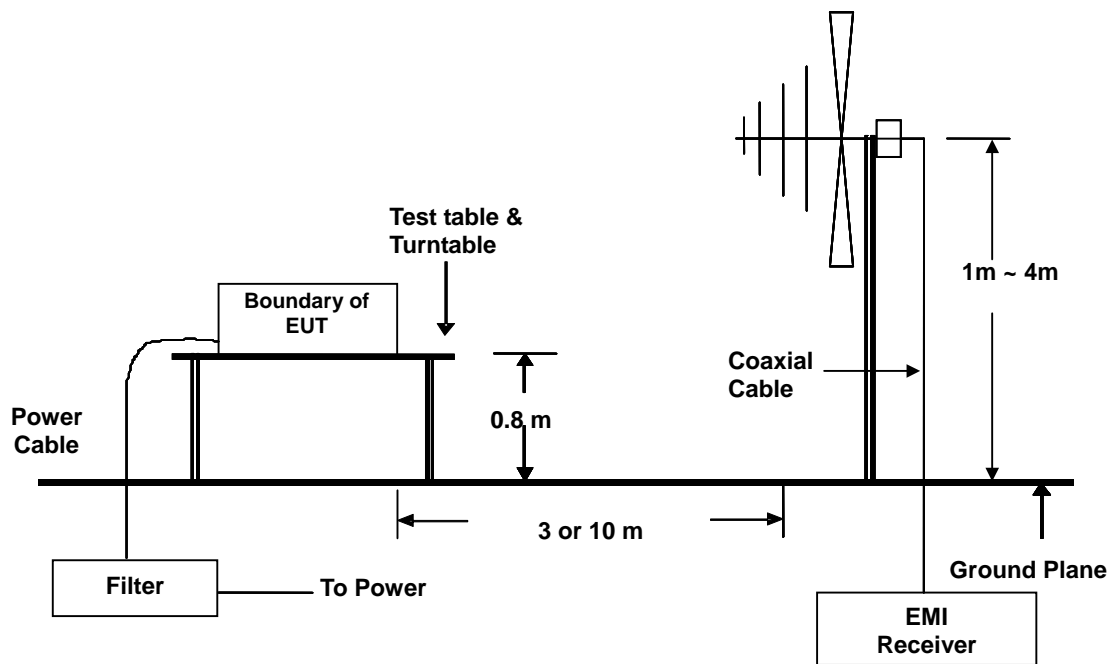

- For the actual test configuration, please refer to the related item - Photographs of the Test Configuration.



### 7.5. DATA SAMPLE

#### Below 1GHz

Freq. (MHz)	Reading (dBuV/m)	Factor (dB)	Result (dBuV/m)	Limit (dBuV/m)	Margin (dB)	Detector (P/Q)	Pol. (H/V)
x.xx	14.0	12.2	26.2	40	-13.8	Q	H

#### Above 1GHz

Freq. (MHz)	Reading (dBuV/m)	Factor (dB)	Result (dBuV/m)	Limit (dBuV/m)	Margin (dB)	Detector (P/A)	Pol. (H/V)
x.xx	42.95	0.55	43.50	60	-16.50	A	H

- Freq. = Emission frequency in MHz
- Reading = Uncorrected Analyzer/Receiver reading
- Factor = Antenna Factor + Cable Loss - Amplifier Gain
- Result = Reading + Factor
- Limit = Limit stated in standard
- Margin = Reading in reference to limit
- P = Peak Reading
- Q = Quasi-peak Reading
- A = Average Reading
- H = Antenna Polarization: Horizontal
- V = Antenna Polarization: Vertical

#### Calculation Formula

Margin (dB) = Result (dBuV/m) – Limit (dBuV/m)

## 7.6. TEST RESULTS

### Below 1GHz

<b>Model No.</b>	ETX-945GSE	<b>Test Mode</b>	Mode 1
<b>Environmental Conditions</b>	25deg.C, 80% RH, 1010hPa	<b>6dB Bandwidth</b>	120 kHz
<b>Antenna Pole</b>	Vertical / Horizontal	<b>Antenna Distance</b>	10m
<b>Detector Function</b>	Quasi-peak.	<b>Tested by</b>	John Yen

(The chart below shows the highest readings taken from the final data.)

Six Highest Radiated Emission Readings							
Frequency Range Investigated				30 MHz to 1000 MHz at 10m			
Freq. (MHz)	Reading (dBuV/m)	Factor (dB)	Result (dBuV/m)	Limit (dBuV/m)	Margin (dB)	Detector (P/Q)	Pol. (H/V)
<b>51.850</b>	<b>50.60</b>	<b>-18.53</b>	<b>32.07</b>	<b>40.00</b>	<b>-7.93</b>	<b>Q</b>	<b>V</b>
<b>71.978</b>	<b>55.30</b>	<b>-21.53</b>	<b>33.77</b>	<b>40.00</b>	<b>-6.23</b>	<b>Q</b>	<b>V</b>
<b>110.180</b>	<b>44.70</b>	<b>-16.46</b>	<b>28.24</b>	<b>40.00</b>	<b>-11.76</b>	<b>Q</b>	<b>V</b>
<b>166.010</b>	<b>44.70</b>	<b>-17.83</b>	<b>26.87</b>	<b>40.00</b>	<b>-13.13</b>	<b>Q</b>	<b>V</b>
<b>499.640</b>	<b>41.58</b>	<b>-8.03</b>	<b>33.55</b>	<b>47.00</b>	<b>-13.45</b>	<b>Q</b>	<b>V</b>
<b>992.976</b>	<b>33.25</b>	<b>-1.74</b>	<b>31.51</b>	<b>47.00</b>	<b>-15.49</b>	<b>Q</b>	<b>V</b>

(The chart below shows the highest readings taken from the final data.)

Six Highest Radiated Emission Readings							
Frequency Range Investigated				30 MHz to 1000 MHz at 10m			
Freq. (MHz)	Reading (dBuV/m)	Factor (dB)	Result (dBuV/m)	Limit (dBuV/m)	Margin (dB)	Detector (P/Q)	Pol. (H/V)
<b>51.853</b>	<b>44.70</b>	<b>-18.54</b>	<b>26.16</b>	<b>40.00</b>	<b>-13.84</b>	<b>Q</b>	<b>H</b>
<b>84.290</b>	<b>46.54</b>	<b>-20.31</b>	<b>26.23</b>	<b>40.00</b>	<b>-13.77</b>	<b>Q</b>	<b>H</b>
<b>110.170</b>	<b>43.61</b>	<b>-16.46</b>	<b>27.15</b>	<b>40.00</b>	<b>-12.85</b>	<b>Q</b>	<b>H</b>
<b>166.130</b>	<b>45.65</b>	<b>-17.83</b>	<b>27.82</b>	<b>40.00</b>	<b>-12.18</b>	<b>Q</b>	<b>H</b>
<b>499.620</b>	<b>44.14</b>	<b>-8.03</b>	<b>36.11</b>	<b>47.00</b>	<b>-10.89</b>	<b>Q</b>	<b>H</b>
<b>540.100</b>	<b>41.78</b>	<b>-6.54</b>	<b>35.24</b>	<b>47.00</b>	<b>-11.76</b>	<b>Q</b>	<b>H</b>

**Note:**

1. 30MHz to 1000MHz test is Applicable CISPR 22 / EN 55022 standard.
2. The other emission levels were very low against the limit.
3. P= Peak Reading; Q= Quasi-peak Reading.

**Above 1000MHz**

<b>Model No.</b>	ETX-945GSE	<b>Test Mode</b>	Mode 1
<b>Environmental Conditions</b>	18deg.C, 60% RH, 1008hPa	<b>6dB Bandwidth</b>	1 MHz
<b>Antenna Pole</b>	Vertical / Horizontal	<b>Antenna Distance</b>	3m
<b>Highest frequency generated or used</b>	1600MHz	<b>Upper frequency</b>	8000MHz
<b>Detector Function</b>	Peak or average.	<b>Tested by</b>	Howard Pang

(The chart below shows the highest readings taken from the final data.)

<b>Radiated Emission Readings</b>							
<b>Frequency Range Investigated</b>				<b>Above 1GHz at 3m</b>			
Freq. (MHz)	Reading (dBUV/m)	Factor (dB)	Result (dBUV/m)	Limit (dBUV/m)	Margin (dB)	Detector (P/A)	Pol. (H/V)
<b>1112.500</b>	<b>46.50</b>	<b>-8.97</b>	<b>37.53</b>	<b>80.00</b>	<b>-42.47</b>	<b>P</b>	<b>V</b>
<b>1337.500</b>	<b>46.53</b>	<b>-7.68</b>	<b>38.85</b>	<b>80.00</b>	<b>-41.15</b>	<b>P</b>	<b>V</b>
<b>1500.000</b>	<b>48.37</b>	<b>-6.75</b>	<b>41.62</b>	<b>80.00</b>	<b>-38.38</b>	<b>P</b>	<b>V</b>
<b>2000.000</b>	<b>45.89</b>	<b>-3.66</b>	<b>42.23</b>	<b>80.00</b>	<b>-37.77</b>	<b>P</b>	<b>V</b>
<b>2350.000</b>	<b>45.31</b>	<b>-2.44</b>	<b>42.87</b>	<b>80.00</b>	<b>-37.13</b>	<b>P</b>	<b>V</b>
<b>2975.000</b>	<b>44.80</b>	<b>0.32</b>	<b>45.12</b>	<b>80.00</b>	<b>-34.88</b>	<b>P</b>	<b>V</b>

(The chart below shows the highest readings taken from the final data.)

<b>Radiated Emission Readings</b>							
<b>Frequency Range Investigated</b>				<b>Above 1GHz at 3m</b>			
Freq. (MHz)	Reading (dBUV/m)	Factor (dB)	Result (dBUV/m)	Limit (dBUV/m)	Margin (dB)	Detector (P/Q)	Pol. (H/V)
<b>1300.000</b>	<b>46.50</b>	<b>-7.90</b>	<b>38.60</b>	<b>80.00</b>	<b>-43.40</b>	<b>P</b>	<b>H</b>
<b>1500.000</b>	<b>51.20</b>	<b>-6.75</b>	<b>44.45</b>	<b>80.00</b>	<b>-35.55</b>	<b>P</b>	<b>H</b>
<b>1900.000</b>	<b>44.37</b>	<b>-4.28</b>	<b>40.09</b>	<b>80.00</b>	<b>-39.91</b>	<b>P</b>	<b>H</b>
<b>2125.000</b>	<b>45.00</b>	<b>-3.23</b>	<b>41.77</b>	<b>80.00</b>	<b>-38.23</b>	<b>P</b>	<b>H</b>
<b>2462.500</b>	<b>47.47</b>	<b>-2.05</b>	<b>45.42</b>	<b>80.00</b>	<b>-34.58</b>	<b>P</b>	<b>H</b>
<b>2900.000</b>	<b>44.11</b>	<b>-0.03</b>	<b>44.08</b>	<b>80.00</b>	<b>-35.92</b>	<b>P</b>	<b>H</b>

**Note:**

1. The other emission levels were very low against the limit.
2. P= Peak Reading; A= Average Reading.

## 8 PHOTOGRAPHS OF THE TEST CONFIGURATION CONDUCTED EMISSION TEST



### RADIATED EMISSION TEST

