



**Spectrum Research  
& Testing Lab., Inc.**

No. 101-10, Ling 8,  
Shan-Tong Li, Chung-Li  
City, Taoyuan, Taiwan,  
R.O.C.

# TEST REPORT

Reference No.:A04060204  
Report No.:FCAA03053001-03  
Page:1 of 27  
Issued Date:Jun. 03, 2004

Product Name: ETX CPU Module  
Model No.: ETX-625  
Applicant: AAEON TECHNOLOGY INC.  
5F, NO. 135, LANE 235, PAO CHIAO RD., HSIN-TIEN  
CITY, TAIPEI, TAIWAN, R.O.C.  
Date of Receipt: Sep. 01, 2003  
Finished date of Test: Oct. 30, 2003  
Applicable Standards: 47 CFR Part 15, Subpart B, Class A  
ANSI C63.4:1992

We, **Spectrum Research & Testing Laboratory Inc.**, hereby certify that one sample of the above was tested in our laboratory with positive results according to the above-mentioned standards. The records in the report are an accurate account of the results. Details of the results are given in the subsequent pages of this report.

Checked By : Jun Chen for , Date: 2004.06.03  
( Sunyou Chen )

Approved By : James Ho , Date: Jun 03, 2004  
( Johnson Ho, Director )

NVLAQ®

Lab Code: 200099-0



## Table of Contents

1.	DOCUMENT POLICY AND TEST STATEMENT .....	3
1.1	DOCUMENT POLICY .....	3
1.2	TEST STATEMENT .....	3
2.	DESCRIPTION OF EUT AND TEST MODE .....	4
2.1	GENERAL DESCRIPTION OF EUT .....	4
2.2	DESCRIPTION OF EUT INTERNAL DEVICE .....	4
2.3	DESCRIPTION OF TEST MODE .....	5
2.4	DESCRIPTION OF SUPPORT UNIT .....	6
3.	DESCRIPTION OF APPLIED STANDARDS .....	7
4.	CONDUCTED EMISSION TEST .....	8
4.1	CONDUCTED EMISSION LIMIT .....	8
4.2	TEST EQUIPMENT .....	8
4.3	TEST SETUP .....	9
4.4	TEST PROCEDURE .....	9
4.5	EUT OPERATING CONDITION .....	10
4.6	TEST RESULT .....	11
5.	RADIATED EMISSION TEST .....	13
5.1	RADIATED EMISSION LIMIT .....	13
5.2	TEST EQUIPMENT .....	14
5.3	TEST SET-UP .....	15
5.4	TEST PROCEDURE .....	16
5.5	EUT OPERATING CONDITION .....	16
5.6	RADIATED EMISSION TEST RESULT .....	17
6.	PHOTOS OF TESTING .....	21
7.	TERMS OF ABRIVATION .....	27



## 1. DOCUMENT POLICY AND TEST STATEMENT

### 1.1 DOCUMENT POLICY

- The report shall not be reproduced except in full, without the written approval of SRT Lab, Inc.
- The report must not be used by the applicant to claim that the product is endorsed by NVLAP, TÜV, NEMKO and SRT.
- The NVLAP logo applies only to the applicable standards specified in this report.

### 1.2 TEST STATEMENT

- The test results in the report apply only to the unit tested by SRT Lab.
- There was no deviation from the requirements of test standards during the test.
- AC power source, 120 Vac/60 Hz, was used during the test.

**Spectrum Research  
& Testing Lab., Inc.**No. 101-10, Ling 8,  
Shan-Tong Li, Chung-Li  
City, Taoyuan, Taiwan,  
R.O.C.**TEST REPORT**Reference No.:A04060204  
Report No.:FCAA03053001-03  
Page:4 of 27  
Issued Date:Jun. 03, 2004**2. DESCRIPTION OF EUT AND TEST MODE****2.1 GENERAL DESCRIPTION OF EUT**

<b>PRODUCT</b>	ETX CPU Module
<b>MODEL NO.</b>	ETX-625
<b>POWER SUPPLY</b>	DC from PC
<b>CABLE</b>	N/A

**NOTE :**

For more detailed information, please refer to the EUT's specification or user's manual provided by manufacturer.

**2.2 DESCRIPTION OF EUT INTERNAL DEVICE**

<b>DEVICE</b>	<b>BRAND / MAKER</b>	<b>MODEL #</b>	<b>FCC ID/DOC</b>	<b>REMARK</b>
N/A				

**NOTE :**

1. Frequency range to be measured.  
Radiated emission is 30MHz to 4.7GHz.



## 2.3 DESCRIPTION OF TEST MODE

The EUT was pre-tested under the following video resolution:

640x480, 1024x768 and 1600x1200

The worst emission was found under 1600x1200 and therefore the test data of only this mode is recorded.

The EUT was tested for emission measurement under the following situations:

Mode	Output
1	CRT+LCD
2	CRT+TV



## 2.4 DESCRIPTION OF SUPPORT UNIT

The EUT was configured by the requirement of ANSI C63.4:1992 and CISRP22:1997. All interface ports were connected to the appropriate support units via specific cables. The support units and cables are listed below.

NO	DEVICE	BRAND	MODEL #	FCC ID/DOC	CABLE
1	MONITOR	SAMSUNG	PG17IS	DOC	1.5m unshielded power cord 1.2m shielded data cable
2	PRINTER	EPSON	STYLUS C20SX	DOC	1.5m unshielded power cord 1.2m shielded data cable
3	MODEM	ACEEX	DM-1414	DOC	1.5m unshielded DC power cable 1.2m shielded data cable
4	MODEM	ACEEX	DM-1414	DOC	1.5m unshielded DC power cable 1.2m shielded data cable
5	MODEM	ACEEX	DM-1414	DOC	1.5m unshielded DC power cable 1.2m shielded data cable
6	KEYBOARD	IBM	SK-8820	DOC	1.5m unshielded data cable
7	MOUSE	IBM	MU29J	DOC	1.5m unshielded data cable
8	USB 2.0 HDD	TERASYS	F12-U	DOC	1.5m unshielded power cord 1.2m shielded data cable
9	USB 2.0 HDD	TERASYS	F12-U	DOC	1.5m unshielded power cord 1.2 shielded data cable
10	1394 HDD	TERASYS	F12-U	DOC	1.5m unshielded power cord 1.2m shielded data cable
11	1394 HDD	TERASYS	F12-U	DOC	1.5m unshielded power cord 1.2 shielded data cable
12	TV	PANASONIC	TC-14S10R2	N/A	1.8 unshielded power cord
13	SPEAKER	JS	J-205A	N/A	1.5 unshielded power cord 1.2 unshielded data cable
14	MP3 PLAYER	CURSOR	GSR-A01C	DOC	1.2m shielded data cable
15	MIC	TAKY	UDM-606	N/A	1.8m unshielded data cable
16	MODULAR PANEL PC	ARBOR	P1506	DOC	N/A

**NOTE :** For the actual test configuration, please refer to the photos of testing.



**Spectrum Research  
& Testing Lab., Inc.**

No. 101-10, Ling 8,  
Shan-Tong Li, Chung-Li  
City, Taoyuan, Taiwan,  
R.O.C.

# TEST REPORT

Reference No.:A04060204  
Report No.:FCAA03053001-03  
Page:7 of 27  
Issued Date:Jun. 03, 2004

### 3. DESCRIPTION OF APPLIED STANDARDS

The EUT could be used in industrial environment information provided by the applicant, it must comply with the requirements of the following standards:

47 CFR Part 15 Subpart B, Class A

All tests have been performed and recorded as per the above standards.



## 4. CONDUCTED EMISSION TEST

### 4.1 CONDUCTED EMISSION LIMIT

FREQUENCY (MHz)	Class A (dB $\mu$ V)		Class B (dB $\mu$ V)	
	Quasi-peak	Average	Quasi-peak	Average
0.15 - 0.5	79	66	66 - 56	56 - 46
0.5 - 5.0	73	60	56	46
5.0 - 30.0	73	60	60	50

**NOTE:**

1. The lower limit shall apply at the transition frequencies.
2. The limit decreases in line with the logarithm of the frequency in the range of 0.15 to 0.50 MHz.

### 4.2 TEST EQUIPMENT

The following test equipment was used for the test:

EQUIPMENT/ FACILITIES	SPECIFICATIONS	MANUFACTURER	MODEL#/ SERIAL#	DUE DATE OF CAL. & CAL. CENTER
EMI TEST RECEIVER	9 kHz TO 2750 MHz	ROHDE & SCHWARZ	ESCS30/ 830245/012	AUG. 2004 ETC
LISN (for EUT)	50 $\mu$ H, 50 ohm	SOLAR ELECTRONICS	8012-50-R-24-BNC / 924839	JUN. 2004 ETC
LISN (for Peripheral)	50 $\mu$ H, 50 ohm	SOLAR ELECTRONICS	9252-50-R-24-BNC / 951318	JUN. 2004 ETC
50 ohm TERMINATOR	50 ohm	HP	11593A/ 2	MAY 2004 ETC
COAXIAL CABLE	3m	SUNCITY	J400/ 3M	JUL. 2004 SRT
ISOLATION TRANSFORMER	N/A	APC	AFC-11015/ F102040016	N/A
FILTER	2 LINE, 30A	FIL.COIL	FC-943/ 771	N/A
GROUND PLANE	2.3M (H) x 2.4M (W)	SRT	N/A	APR. 2004 SRT
GROUND PLANE	2.4M (H) x 2.4M (W)	SRT	N/A	APR. 2004 SRT

**NOTE:** The calibration interval of the above test equipment is one year and the calibrations are traceable to NML/ROC and NIST/USA.





## 4.3 TEST SETUP

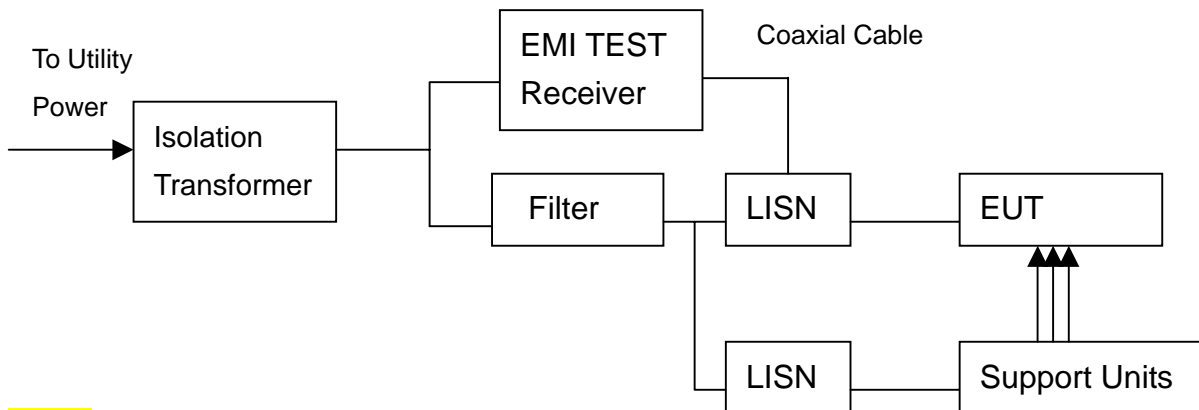

### NOTE:

1. The EUT was put on a wooden table with 0.8m height above ground plane, and 0.4m away from reference ground plane (> 2mx2m).
2. For the actual test configuration, please refer to the photos of testing.
3. The serial no. of the LISN connected to EUT is 951318.
4. The serial no. of the LISN connected to support units is 924839.

## 4.4 TEST PROCEDURE

The EUT was tested according to the requirement of ANSI C63.4:1992 and CISRP22:1997. The frequency spectrum from 0.15 MHz to 30 MHz was investigated. The LISN used was 50 ohm/50 $\mu$ H as specified. All readings were quasi-peak and average values with 10 kHz resolution bandwidth of the test receiver. The EUT system was operated in all typical methods by users. Both lines of the power mains of EUT were measured and the cables connected to EUT and support units were moved to find the maximum emission levels for each frequency. First, Find the margin or higher points at least 6 points by software, then use manual to find the maximum data. The procedure is referred on the test procedure of SRT LAB.



## 4.5 EUT OPERATING CONDITION

1. Under WIN 2000 ran “EMI TEST”, “WIN FCC”, “XCOPY” and “Media Player” programs.
2. PC sent "H" pattern or accessed the following peripherals directly or via EUT:
  - Color Monitor
  - RS232
  - Keyboard
  - Mouse
  - Printer
  - FDD
  - HDD
3. Accessed data from internet.



## 4.6 TEST RESULT

Temperature:	<u>25 °C</u>	Humidity:	<u>51 %RH</u>
Ferquency Range:	<u>0.15 – 30 MHz</u>	Tested Mode:	<u>1 (CRT+LCD)</u>
Receiver Detector:	<u>Q.P. and AV.</u>	Tested By:	<u>Shunm Wang</u>
		Tested Date:	<u>Oct. 17, 2003</u>

Power Line Measured : Line

Freq. (MHz)	Correct. Factor (dB)	Reading Value (dB $\mu$ V)		Emission Level (dB $\mu$ V)		Limit (dB $\mu$ V)		Margin (dB)	
		Q.P.	AV.	Q.P.	AV.	Q.P.	AV.	Q.P.	AV.
0.240	0.20	40.1	34.6	40.3	34.8	79.0	66.0	-38.7	-31.2
0.349	0.20	42.7	35.1	42.9	35.3	79.0	66.0	-36.1	-30.7
0.709	0.20	34.6	28.9	34.8	29.1	73.0	60.0	-38.2	-30.9
1.244	0.20	30.1	25.3	30.3	25.5	73.0	60.0	-42.7	-34.5
7.009	0.35	44.5	41.9	44.8	42.2	73.0	60.0	-28.2	-17.8
8.224	0.37	34.0	29.1	34.4	29.5	73.0	60.0	-38.6	-30.5

Power Line Measured : Neutral

Freq. (MHz)	Correct. Factor (dB)	Reading Value (dB $\mu$ V)		Emission Level (dB $\mu$ V)		Limit (dB $\mu$ V)		Margin (dB)	
		Q.P.	AV.	Q.P.	AV.	Q.P.	AV.	Q.P.	AV.
0.246	0.20	43.4	38.6	43.6	38.8	79.0	66.0	-35.4	-27.2
0.353	0.20	42.3	30.4	42.5	30.6	79.0	66.0	-36.5	-35.4
0.697	0.20	29.4	22.5	29.6	22.7	73.0	60.0	-43.4	-37.3
1.521	0.20	22.2	16.9	22.4	17.1	73.0	60.0	-50.6	-42.9
6.861	0.35	42.5	40.1	42.8	40.4	73.0	60.0	-30.2	-19.6
8.130	0.37	34.1	32.8	34.5	33.2	73.0	60.0	-38.5	-26.8

### NOTE :

1. Measurement uncertainty is +/-2dB
2. Emission level = Reading value + Correction factor
3. Correction Factor = Cable loss + Insertion loss of LISN
4. Margin value = Emission level - Limit
5. The emission of other frequencies were very low against the limit.
6. "-": The Quasi-peak reading value also meets average limit and measurement with the average detector is unnecessary.



Temperature:	<u>25 °C</u>	Humidity:	<u>51 %RH</u>
Frequency Range:	<u>0.15 – 30 MHz</u>	Tested Mode:	<u>2 (CRT+TV)</u>
Receiver Detector:	<u>Q.P. and AV.</u>	Tested By:	<u>Shunm Wang</u>
		Tested Date:	<u>Oct. 17, 2003</u>

Power Line Measured : Line

Freq. (MHz)	Correct. Factor (dB)	Reading Value (dB $\mu$ V)		Emission Level (dB $\mu$ V)		Limit (dB $\mu$ V)		Margin (dB)	
		Q.P.	AV.	Q.P.	AV.	Q.P.	AV.	Q.P.	AV.
0.213	0.20	46.6	35.6	46.8	35.8	79.0	66.0	-32.2	-30.2
0.427	0.20	41.2	20.1	41.4	20.3	79.0	66.0	-37.6	-45.7
0.869	0.20	36.6	19.9	36.8	20.1	73.0	60.0	-36.2	-39.9
7.060	0.35	38.4	30.1	38.7	30.4	73.0	60.0	-34.3	-29.6
8.466	0.37	52.3	38.6	52.7	39.0	73.0	60.0	-20.3	-21.0
28.638	0.77	40.3	38.8	41.1	39.6	73.0	60.0	-31.9	-20.4

Power Line Measured : Neutral

Freq. (MHz)	Correct. Factor (dB)	Reading Value (dB $\mu$ V)		Emission Level (dB $\mu$ V)		Limit (dB $\mu$ V)		Margin (dB)	
		Q.P.	AV.	Q.P.	AV.	Q.P.	AV.	Q.P.	AV.
0.209	0.20	40.1	31.2	40.3	31.4	79.0	66.0	-38.7	-34.6
0.552	0.20	32.3	21.3	32.5	21.5	73.0	60.0	-40.5	-38.5
0.611	0.20	32.2	21.6	32.4	21.8	73.0	60.0	-40.6	-38.2
1.283	0.20	31.4	18.6	31.6	18.8	73.0	60.0	-41.4	-41.2
4.353	0.30	25.0	19.1	25.3	19.4	73.0	60.0	-47.7	-40.6
14.318	0.49	39.6	39.4	40.1	39.9	73.0	60.0	-32.9	-20.1

**NOTE :**

1. Measurement uncertainty is +/-2dB
2. Emission level = Reading value + Correction factor
3. Correction Factor = Cable loss + Insertion loss of LISN
4. Margin value = Emission level - Limit
5. The emission of other frequencies were very low against the limit.
6. "-": The Quasi-peak reading value also meets average limit and measurement with the average detector is unnecessary.



## 5. RADIATED EMISSION TEST

### 5.1 RADIATED EMISSION LIMIT

CISPR 22:1997 limits of radiated emission measurement for frequency below 1000 MHz

FREQUENCY (MHz)	Class A (at 10m)	Class B (at 10m)
	dB $\mu$ V/m	dB $\mu$ V/m
30 – 230	40	30
230 - 1000	47	37

**NOTE:**

1. The lower limit shall apply at the transition frequencies.
2. Emission level (dB $\mu$ V/m) = 20 log Emission level ( $\mu$ V/m).

FCC Part 15, Subpart B limit of radiated emission for frequency above 1000 MHz

FREQUENCY (MHz)	Class A (dB $\mu$ V/m) (at 3m)		Class B (dB $\mu$ V/m) (at 3m)	
	PEAK	AVERAGE	PEAK	AVERAGE
Above 1000	80.0	60.0	74.0	54.0



## 5.2 TEST EQUIPMENT

The following test equipment was used during the radiated emission test:

EQUIPMENT/ FACILITIES	SPECIFICATIONS	MANUFACTURER	MODEL#/ SERIAL#	DUE DATE OF CAL. & CAL. CENTER
EMI TEST RECEIVER	20 MHz TO 1 GHz	ROHDE & SCHWARZ	ESVS30/ 841977/003	AUG. 2004 ETC
BI-LOG ANTENNA	25 MHz TO 2 GHz	EMCO	3142/ 9701-1124	APR. 2004 SRT
SPECTRUM ANALYZER	9 KHz TO 26.5 GHz	HP	8593E/ 3710A03220	MAY 2004 ETC
PRE-AMPLIFIER	1 GHz TO 26.5 GHz	HP	8449B/ 3008A01019	DEC. 2003 ETC
HORN ANTENNA	1 GHz TO 18 GHz	EMCO	3115/ 9602-4681	DEC. 2003 ETC
OATS	3 – 10 M MEASUREMENT	SRT	SRT-1	APR. 2004 SRT
COAXIAL CABLE	25M	SUNCITY	J400/ 25M	AUG. 2004 SRT
FILTER	2 LINE, 30A	FIL.COIL	FC-943/ 869	N/A
FREQUENCY CONVERTER	N/A	APC	AFC-2KBB/ F100030031	AUG. 2004 SRT

### NOTE:

1. The calibration interval of the above test equipment is one year and the calibrations are traceable to NML/ROC and NIST/USA.
2. The Open Area Test Site (SRT-1) is registered by FCC with No. 90957 and VCCI with No. R-1081.
3. The Open Area Test Site (SRT-2) is registered by FCC with No. 98458 and VCCI with No. R-1168.



## 5.3 TEST SET-UP

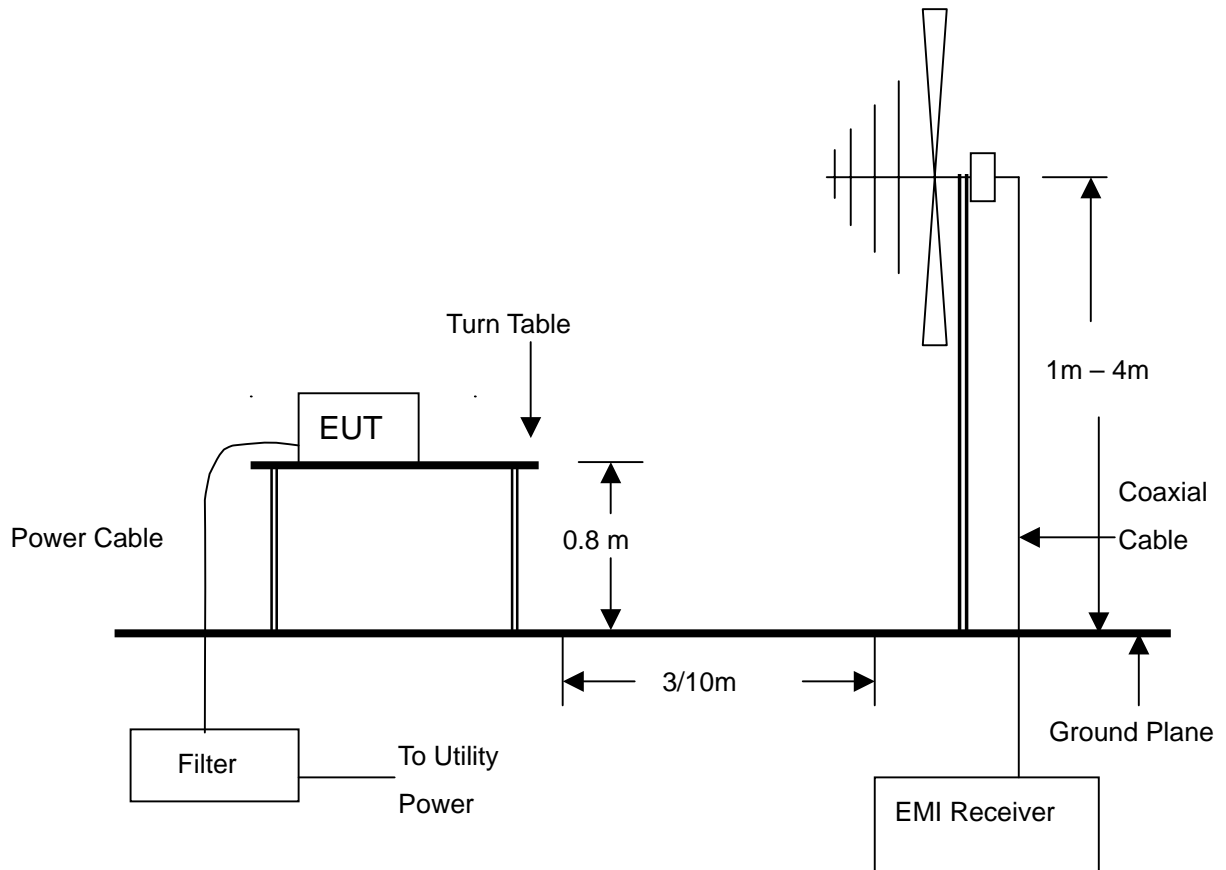

### NOTE :

1. The EUT system was put on a wooden table with 0.8m heights above a ground plane.
2. For the actual test configuration, please refer to the photos of testing.



## 5.4 TEST PROCEDURE

The EUT was tested according to the requirement of ANSI C63.4:1992 and CISPR 22:1997. The measurements were made at an open area test site with 10 meter measurement distance under 1 GHz and with 3m distance above 1GHz. The frequency spectrum measured started from 30 MHz. Under 1 GHz, all readings were quasi-peak values with 120 kHz resolution bandwidth of the test receiver. Above 1 GHz, the measurements were made at an open area test site with 3 meter measurement distance and all readings were peak or average values with 1 MHz resolution bandwidth of the test receiver. The EUT system was operated in all typical methods by users. The cables connected to EUT and support units were moved to find the maximum emission levels for each frequency. First, Find the margin or higher points at least 6 points by software, then use manual to find the maximum data. The procedure is referred on the test procedure of SRT LAB.

## 5.5 EUT OPERATING CONDITION

Same as section 4.5 of this report.





## 5.6 RADIATED EMISSION TEST RESULT

Temperature:	25 °C	Humidity:	53 %RH
Ferquency Range:	30 – 1000 MHz	Measured Distance:	10m
Receiver Detector:	Q.P.	Tested Mode:	1 (CRT+LCD)
Tested By:	Shunm Wang	Tested Date:	Oct. 17, 2003

Antenna Polarization:Horizontal

Frequency (MHz)	Cable Loss (dB)	Antenna Factor (dB/m)	Reading Data (dBμV)	Emission Level (dBμV/m)	Limit (dBμV/m)	Margin (dB)	AZ(°)	EL(m)
45.4664	0.73	11.05	17.4	29.2	40.0	-10.8	355.6	4.00
66.5510	0.85	7.30	16.4	24.5	40.0	-15.5	131.6	4.00
71.9978	0.90	7.10	18.0	26.0	40.0	-14.0	129.1	4.00
84.4332	0.92	7.38	16.5	24.8	40.0	-15.2	152.1	4.00
133.1570	1.11	7.44	22.0	30.5	40.0	-9.5	262.6	4.00
214.2916	1.35	10.26	20.0	31.6	40.0	-8.4	188.0	3.60

Antenna Polarization:Vertical

Frequency (MHz)	Cable Loss (dB)	Antenna Factor (dB/m)	Reading Data (dBμV)	Emission Level (dBμV/m)	Limit (dBμV/m)	Margin (dB)	AZ(°)	EL(m)
45.4664	0.73	11.05	23.2	35.0	40.0	-5.0	121.1	1.00
57.2720	0.77	8.05	24.3	33.1	40.0	-6.9	235.9	1.00
66.6984	0.85	7.30	21.2	29.3	40.0	-10.7	227.2	1.10
71.4220	0.90	7.10	22.0	30.0	40.0	-10.0	254.3	2.03
84.4134	0.92	7.38	21.5	29.8	40.0	-10.2	76.3	1.58
133.1570	1.11	7.44	23.2	31.7	40.0	-8.3	200.3	1.00

### NOTE :

1. Measurement uncertainty is +/-4dB.
2. "": Measurement does not apply for this frequency.
3. Emission Level = Reading Value + Ant. Factor + Cable Loss.
4. The field strength of other emission frequencies were very low against the limit.



Temperature:	25 °C	Humidity:	53 %RH
Frequency Range:	30 – 1000 MHz	Measured Distance:	10m
Receiver Detector:	Q.P.	Tested Mode:	2 (CRT+TV)
Tested By:	Shunm Wang	Tested Date:	Oct. 17, 2003

Antenna Polarization:Horizontal

Frequency (MHz)	Cable Loss (dB)	Antenna Factor (dB/m)	Reading Data (dBµV)	Emission Level (dBµV/m)	Limit (dBµV/m)	Margin (dB)	AZ(°)	EL(m)
66.6830	0.85	7.30	18.3	26.4	40.0	-13.6	340.1	4.00
169.2200	1.22	8.99	17.0	27.2	40.0	-12.8	140.2	3.90
179.8674	1.24	10.35	15.9	27.5	40.0	-12.5	119.3	4.00
196.6721	1.35	10.10	15.4	26.9	40.0	-13.2	149.2	4.00
225.7390	1.40	10.60	18.9	30.9	40.0	-9.1	251.9	3.80
533.5699	2.26	19.26	16.1	37.6	47.0	-9.4	198.2	3.20

Antenna Polarization:Vertical

Frequency (MHz)	Cable Loss (dB)	Antenna Factor (dB/m)	Reading Data (dBµV)	Emission Level (dBµV/m)	Limit (dBµV/m)	Margin (dB)	AZ(°)	EL(m)
56.5831	0.77	8.20	21.9	30.9	40.0	-9.1	135.2	1.00
66.6990	0.85	7.30	19.5	27.6	40.0	-12.4	250.1	1.00
84.5222	0.92	7.38	20.9	29.2	40.0	-10.8	222.3	1.20
197.6285	1.35	10.05	21.5	32.9	40.0	-7.1	238.8	1.30
322.8564	1.70	14.90	18.4	35.0	47.0	-12.0	201.6	1.20
533.4537	2.26	19.26	17.9	39.4	47.0	-7.6	190.5	1.90

**NOTE :**

1. Measurement uncertainty is +/-4dB.
2. "\*\*": Measurement does not apply for this frequency.
3. Emission Level = Reading Value + Ant. Factor + Cable Loss.
4. The field strength of other emission frequencies were very low against the limit.



Temperature:	25 °C	Humidity:	53 %RH
Frequency Range:	1 – 4.7 GHz	Measured Distance:	3m
Receiver Detector:	PK. or AV.	Tested Mode:	1 (CRT+LCD)
Tested By:	Shunm Wang	Tested Date:	Oct. 17, 2003

Antenna Polarization : Horizontal

Frequency (MHz)	Correct Factor (dB)	Antenna Factor (dB/m)	Reading Data (dB $\mu$ V)		Emission Level (dB $\mu$ V/m)		Limit (dB $\mu$ V/m)		Margin (dB)		AZ (°)	EL (m)
			PK.	AV.	PK.	AV.	PK.	AV.	PK.	AV.		
1071.1300	-34.61	24.40	69.8	60.2	59.6	50.0	80.0	60.0	-20.4	-10.0	35.6	1.00
1336.8300	-33.07	24.94	62.5	53.4	54.4	45.3	80.0	60.0	-25.6	-14.7	268.1	1.20
1603.6500	-32.92	25.69	65.1	56.7	57.9	49.5	80.0	60.0	-22.1	-10.5	168.4	1.00
1735.2200	-33.00	26.19	64.1	55.8	57.3	49.0	80.0	60.0	-22.7	-11.0	321.6	1.16
3406.9600	-31.46	32.22	60.2	51.9	61.0	52.7	80.0	60.0	-19.0	-7.3	94.2	1.50
4840.9800	-30.37	33.67	61.9	52.5	65.2	55.8	80.0	60.0	-14.8	-4.2	106.7	1.33

Antenna Polarization : Vertical

Frequency (MHz)	Correct Factor (dB)	Antenna Factor (dB/m)	Reading Data (dB $\mu$ V)		Emission Level (dB $\mu$ V/m)		Limit (dB $\mu$ V/m)		Margin (dB)		AZ (°)	EL (m)
			PK.	AV.	PK.	AV.	PK.	AV.	PK.	AV.		
1070.9000	-34.61	24.35	71.2	62.5	60.9	52.2	80.0	60.0	-19.1	-7.8	195.6	1.00
1205.1900	-33.86	24.65	65.2	56.8	56.0	47.6	80.0	60.0	-24.0	-12.4	275.6	1.30
1336.7600	-33.07	24.94	64.2	65.6	56.1	57.5	80.0	60.0	-23.9	-2.5	10.2	1.10
1471.3300	-30.21	25.24	63.2	54.9	58.2	49.9	80.0	60.0	-21.8	-10.1	351.0	1.40
3284.5200	-31.77	31.85	58.9	49.2	59.0	49.3	80.0	60.0	-21.0	-10.7	128.4	1.09
4299.1600	-30.27	32.96	59.5	50.1	62.2	52.8	80.0	60.0	-17.8	-7.2	0	1.00

**NOTE :**

1. Measurement uncertainty is 4dB.
2. "\*\*": Measurement does not apply for this frequency.
3. Emission Level = Reading Value + Ant. Factor + Cable Loss.
4. The field strength of other emission frequencies were very low against the limit.
5. "-": The Peak reading value also meets average limit and measurement with the average detector is unnecessary.



Temperature:	25 °C	Humidity:	53 %RH
Frequency Range:	1 – 4.7 GHz	Measured Distance:	3m
Receiver Detector:	PK. or AV.	Tested Mode:	2 (CRT+TV)
Tested By:	Shunm Wang	Tested Date:	Oct. 17, 2003

Antenna Polarization : Horizontal

Frequency (MHz)	Correct Factor (dB)	Antenna Factor (dB/m)	Reading Data (dB $\mu$ V)		Emission Level (dB $\mu$ V/m)		Limit (dB $\mu$ V/m)		Margin (dB)		AZ (°)	EL (m)
			PK.	AV.	PK.	AV.	PK.	AV.	PK.	AV.		
1071.2000	-34.61	24.40	67.1	58.9	56.9	48.7	80.0	60.0	-23.1	-11.3	45.6	1.10
1134.2500	-34.63	24.49	64.2	55.9	54.1	45.8	80.0	60.0	-25.9	-14.2	145.6	1.00
1336.7500	-33.07	24.94	62.1	63.5	54.0	55.4	80.0	60.0	-26.0	-4.6	128.9	1.00
1734.1000	-33.00	26.19	61.6	52.6	54.8	45.8	80.0	60.0	-25.2	-14.2	355.1	1.21
3288.5100	-31.77	31.86	58.5	49.6	58.6	49.7	80.0	60.0	-21.4	-10.3	62.5	1.30
4696.2000	-30.58	33.56	61.0	52.6	64.0	55.6	80.0	60.0	-16.0	-4.4	156.2	1.20

Antenna Polarization : Vertical

Frequency (MHz)	Correct Factor (dB)	Antenna Factor (dB/m)	Reading Data (dB $\mu$ V)		Emission Level (dB $\mu$ V/m)		Limit (dB $\mu$ V/m)		Margin (dB)		AZ (°)	EL (m)
			PK.	AV.	PK.	AV.	PK.	AV.	PK.	AV.		
1071.2200	-34.61	24.36	68.1	59.6	57.8	49.3	80.0	60.0	-22.2	-10.7	240.3	1.00
1133.1200	-34.64	24.49	67.9	58.4	57.8	48.3	80.0	60.0	-22.2	-11.7	211.5	1.10
1468.3500	-30.14	25.23	61.5	52.6	56.6	47.7	80.0	60.0	-23.4	-12.3	40.3	1.41
1603.6100	-32.92	25.69	63.5	54.4	56.3	47.2	80.0	60.0	-23.7	-12.8	309.7	1.20
3067.9500	-32.14	31.20	57.1	48.6	56.2	47.7	80.0	60.0	-23.8	-12.3	179.3	1.00
4955.8900	-30.25	33.76	59.9	50.4	63.4	53.9	80.0	60.0	-16.6	-6.1	50.6	1.20

**NOTE :**

1. Measurement uncertainty is 4dB.
2. "\*": Measurement does not apply for this frequency.
3. Emission Level = Reading Value + Ant. Factor + Cable Loss.
4. The field strength of other emission frequencies were very low against the limit.
5. "-": The Peak reading value also meets average limit and measurement with the average detector is unnecessary.



## 6. PHOTOS OF TESTING

- Conducted test (CRT+LCD)





**Spectrum Research  
& Testing Lab., Inc.**

No. 101-10, Ling 8,  
Shan-Tong Li, Chung-Li  
City, Taoyuan, Taiwan,  
R.O.C.

# TEST REPORT

Reference No.:A04060204  
Report No.:FCAA03053001-03  
Page:22 of 27  
Issued Date:Jun. 03, 2004

- Conducted test (CRT+TV)





- Radiated test (CRT+LCD: Below 1GHz)





**Spectrum Research  
& Testing Lab., Inc.**

No. 101-10, Ling 8,  
Shan-Tong Li, Chung-Li  
City, Taoyuan, Taiwan,  
R.O.C.

# TEST REPORT

Reference No.:A04060204  
Report No.:FCAA03053001-03  
Page:24 of 27  
Issued Date:Jun. 03, 2004

- Radiated test (CRT+TV: Below 1GHz)







**Spectrum Research  
& Testing Lab., Inc.**

No. 101-10, Ling 8,  
Shan-Tong Li, Chung-Li  
City, Taoyuan, Taiwan,  
R.O.C.

# TEST REPORT

Reference No.:A04060204  
Report No.:FCAA03053001-03  
Page:25 of 27  
Issued Date:Jun. 03, 2004

- Radiated test (CRT+LCD: Above 1GHz)





**Spectrum Research  
& Testing Lab., Inc.**

No. 101-10, Ling 8,  
Shan-Tong Li, Chung-Li  
City, Taoyuan, Taiwan,  
R.O.C.

# TEST REPORT

Reference No.:A04060204  
Report No.:FCAA03053001-03  
Page:26 of 27  
Issued Date:Jun. 03, 2004

- Radiated test (CRT+TV: Above 1GHz)



**Spectrum Research  
& Testing Lab., Inc.**

No. 101-10, Ling 8,  
Shan-Tong Li, Chung-Li  
City, Taoyuan, Taiwan,  
R.O.C.

**TEST REPORT**

Reference No.:A04060204  
Report No.:FCAA03053001-03  
Page:27 of 27  
Issued Date:Jun. 03, 2004

**7. TERMS OF ABRIVATION**

AV.	Average detection
AZ(°)	Turn table azimuth
Correct.	Correction
EL(m)	Antenna height (meter)
EUT	Equipment Under Test
Horiz.	Horizontal direction
LISN	Line Impedance Stabilization Network
NSA	Normalized Site Attenuation
Q.P.	Quasi-peak detection
SRT Lab	Spectrum Research & Testing Laboratory, Inc.
Vert.	Vertical direction