

# FCC Verification TEST REPORT

for

**Mini ITX Board**

**MODEL: EMB-9459T-xxxxxxx (Where x is 0-9 , A-Z , - or blank) for marketing purpose**

Test Report Number:  
T100525203-F

Issued to:

**AAEON Technology Inc.**

**5F, No. 135, Lane 235, Pao Chiao Rd., Hsin-Tien City,  
Taipei, Taiwan, R.O.C.**

Issued by:

**Compliance Certification Services Inc.**

**Sindian BU.**

**No.163-1, Jhongsheng Rd., Sindian City,  
Taipei County 23151, Taiwan**

**TEL: 886-2-22170894**

**FAX: 886-2-22171029**

**Issued Date: June 9, 2010**



**Note:** This report shall not be reproduced except in full, without the written approval of Compliance Certification Services Inc. This document may be altered or revised by Compliance Certification Services Inc. personnel only, and shall be noted in the revision section of the document. The client should not use it to claim product endorsement by TAF, A2LA, NVLAP, NIST or any government agencies. The test results in the report only apply to the tested sample.



**Revision History**

Rev.	Issue Date	Revisions	Effect Page	Revised By
00	February 5, 2009	Initial Issue	ALL	Wendy Wang
01	October 13, 2009	1. Update power diagram and I/O port 2. Update Standards	ALL	Wendy Wang
02	June 9, 2010	1. Update internal schematic 2. Add test mode and date	1,4,5,6,14,18	Wendy Wang



**TABLE OF CONTENTS**

**1 TEST RESULT CERTIFICATION..... 4**

**2 EUT DESCRIPTION..... 5**

**3 TEST METHODOLOGY ..... 6**

**3.1. DECISION OF FINAL TEST MODE ..... 6**

**3.2. EUT SYSTEM OPERATION..... 6**

**4 SETUP OF EQUIPMENT UNDER TEST ..... 7**

**4.1. DESCRIPTION OF SUPPORT UNITS ..... 7**

**4.2. CONFIGURATION OF SYSTEM UNDER TEST ..... 8**

**5 FACILITIES AND ACCREDITATIONS ..... 9**

**5.1. FACILITIES ..... 9**

**5.2. ACCREDITATIONS ..... 9**

**5.3. MEASUREMENT UNCERTAINTY ..... 9**

**6 CONDUCTED EMISSION MEASUREMENT..... 10**

**6.1. LIMITS OF CONDUCTED EMISSION MEASUREMENT ..... 10**

**6.2. TEST INSTRUMENTS ..... 10**

**6.3. TEST PROCEDURES..... 11**

**6.4. TEST SETUP ..... 12**

**6.5. DATA SAMPLE..... 12**

**6.6. TEST RESULTS ..... 13**

**7 RADIATED EMISSION MEASUREMENT ..... 14**

**7.1. LIMITS OF RADIATED EMISSION MEASUREMENT ..... 14**

**7.2. TEST INSTRUMENTS ..... 14**

**7.3. TEST PROCEDURES..... 15**

**7.4. TEST SETUP ..... 16**

**7.5. DATA SAMPLE..... 17**

**7.6. TEST RESULTS ..... 18**

**8 PHOTOGRAPHS OF THE TEST CONFIGURATION ..... 20**



# 1 TEST RESULT CERTIFICATION

<b>Product:</b>	Mini ITX Board
<b>Brand:</b>	AAEON
<b>Model:</b>	EMB-9459T-xxxxxxx (Where x is 0-9 , A-Z , - or blank) for marketing purpose
<b>Applicant:</b>	<b>AAEON Technology Inc.</b> 5F, No. 135, Lane 235, Pao Chiao Rd., Hsin-Tien City, Taipei, Taiwan, R.O.C.
<b>Manufacturer:</b>	<b>AAEON Technology Inc.</b> 5F, No. 135, Lane 235, Pao Chiao Rd., Hsin-Tien City, Taipei, Taiwan, R.O.C.
<b>Tested:</b>	February 2, 2009 ~ June 8, 2010

EMISSION			
Standard	Item	Result	Remarks
FCC 47 CFR Part 15 Subpart B, ICES-003 Issue 4 ANSI C63.4-2003	Conducted (Power Port)	PASS	Meet Class A limit
	Radiated	PASS	Meet Class A limit

- Note:**
1. The statements of test result on the above are decided by the request of test standard only; the measurement uncertainties are not factored into this compliance determination.
  2. The information of measurement uncertainty is available upon the customer's request.

Deviation from Applicable Standard
None

The above equipment has been tested by Compliance Certification Services Inc., and found compliance with the requirements set forth in the technical standards mentioned above. The results of testing in this report apply only to the product/system, which was tested. Other similar equipment will not necessarily produce the same results due to production tolerance and measurement uncertainties.

Approved by:

Reviewed by:



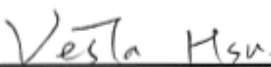

Sam Hu  
Section Manager

Vesta Hsu  
Supervisor of report document dept.



## 2 EUT DESCRIPTION

<b>Product</b>	Mini ITX Board
<b>Brand Name</b>	AAEON
<b>Model</b>	EMB-9459T-xxxxxxx (Where x is 0-9 , A-Z , - or blank) for marketing purpose
<b>Applicant</b>	AAEON Technology Inc.
<b>Housing material</b>	N/A
<b>Identify Number</b>	91006203
<b>Received Date</b>	October 6, 2009
<b>EUT Power Rating</b>	3.3VDC/5VDC/12VDC
<b>AC Power During Test</b>	120VAC / 60 Hz
<b>OSC/Clock Frequencies</b>	14.31818MHz; 25MHz; 32.768kHz

### Model Difference

Report No.	Model Name	Difference	Tested (Checked)
90202201	EMB-9459T	EUT are same, Except power diagram and I/O port difference	<input checked="" type="checkbox"/>
91006203	EMB-9459T		<input checked="" type="checkbox"/>
T100525203	EMB-9459T	EUT are same, Except internal schematic difference	<input checked="" type="checkbox"/>

### I/O PORT

I/O PORT TYPES	Q'TY	TESTED WITH
1) SIO Port	6	6
2) PIO Port	1	1
3) PS/2 Keyboard Port	1	1
4) PS/2 Mouse Port	1	1
5) VGA Port	1	1
6) Microphone Port	1	1
7) Earphone Port	1	1
8) USB Port	8	8
9) LAN Port	2	2

**Note:** Client consigns only one model sample to test (Model Number: EMB-9459T).

### 3 TEST METHODOLOGY

#### 3.1. DECISION OF FINAL TEST MODE

The EUT was tested together with the above additional components, and a configuration, which produced the worst emission levels, was selected and recorded in this report.

The test configuration modes are as the following:

**Conduction Mode:**

1.	Report No.: 90202201	Normal Mode
2.	Report No.: 91006203	Normal Mode

**Radiation Mode:**

1.	Report No.: 90202201	Normal Mode
		Normal Mode / 1-8GHz
2.	Report No.: 91006203	Normal Mode
		Normal Mode / 1-8GHz
3.	Report No.: T100525203	2048X1536

**Conduction:** Mode 2

**Radiation (Below 1GHz):** Mode 3

**Radiation (Above1GHz):** Mode 2

#### 3.2. EUT SYSTEM OPERATION

1. Windows XP boots system.
2. Run Emctest.exe to activate all peripherals and display “H” pattern on monitor screen.
3. Run Winemc.exe and choose media player to play music.
4. Run Winemc.exe and choose “E:/& F:/& G:/ & H:/ & I:/& J:/ & K:/ & L:/” to test EUT.
5. Press the start menu, select executive and type ping 192.168.0.10 -t (EUT), ping 192.168.0.5-t (Server Notebook).
6. Press the start menu, select executive and type ping 192.168.0.10 -t (EUT), ping 192.168.0.4-t (Server Notebook).

**Note:** Test program is self-repeating throughout the test.



## 4 SETUP OF EQUIPMENT UNDER TEST

### 4.1. DESCRIPTION OF SUPPORT UNITS

The EUT has been tested as an independent unit together with other necessary accessories or support units. The following support units or accessories were used to form a representative test configuration during the tests.

#### Host PC Devices:

No.	Equipment	Model No.	Trade Name
1	CPU (1.6GHz)	Atom	Intel
2	Memory (512MB DDR2-533)	E5108AGBG-6E-E	EIPIDA
3	Power Supply	ST-300BLV	Seventeam
4	HDD (40GB)	ST340014A	Seagate

#### Peripherals Devices:

No.	Equipment	Model No.	Serial No.	FCC ID / BSMI ID	Trade Name	Data Cable	Power Cord
1	Earphone & Microphone	MSB301	N/A	N/A	e-Sense	Unshielded, 1.8m	N/A
2	PS/2 Mouse	M-SBF69	HCA54301042	DoC / R41126	Logitech	Shielded, 1.8m	N/A
3	PS/2 Keyboard	Y-SJ17	867247-0121	DoC / T51160	Logitech	Shielded, 1.8m	N/A
4-11	USB 2.0 HDD	F12-U	N/A	BSMI ID: 4912A002	TeraSys	Shielded, 1.8m	N/A
12-14	Modem	5JEG4033MKO	N/A	5RJTAI-35500-M5-E	TOP-SOLUTION	Shielded, 1.8m	Unshielded, 1.8m
15-17	Modem	1414	N/A	IFAXDM1414	ACEEX	Shielded, 1.8m	Unshielded, 1.8m
18	Monitor	710V	GS17H9NXA16497S	DOC BSMI: R33475	SAMSUNG	Shielded, 1.8m with two cores	Unshielded, 1.8m
19	Printer	C60	DR3K039402	BSMI ID:3902E006	EPSON	Shielded, 1.8 m	Unshielded, 1.8m
20	HUB	DGS-1008D	N/A	N/A	D-Link	Unshielded, 20m x2	Unshielded, 1.8m
21	Server Notebook	2210B	CNV7472KG5	DoC BSMI: R33001	HP	Unshielded, 1.0m	Unshielded, 1.8m

#### Note:

- 1) All the equipment/cables were placed in the worst-case configuration to maximize the emission during the test.
- 2) Grounding was established in accordance with the manufacturer's requirements and conditions for the intended use.

## 4.2. CONFIGURATION OF SYSTEM UNDER TEST

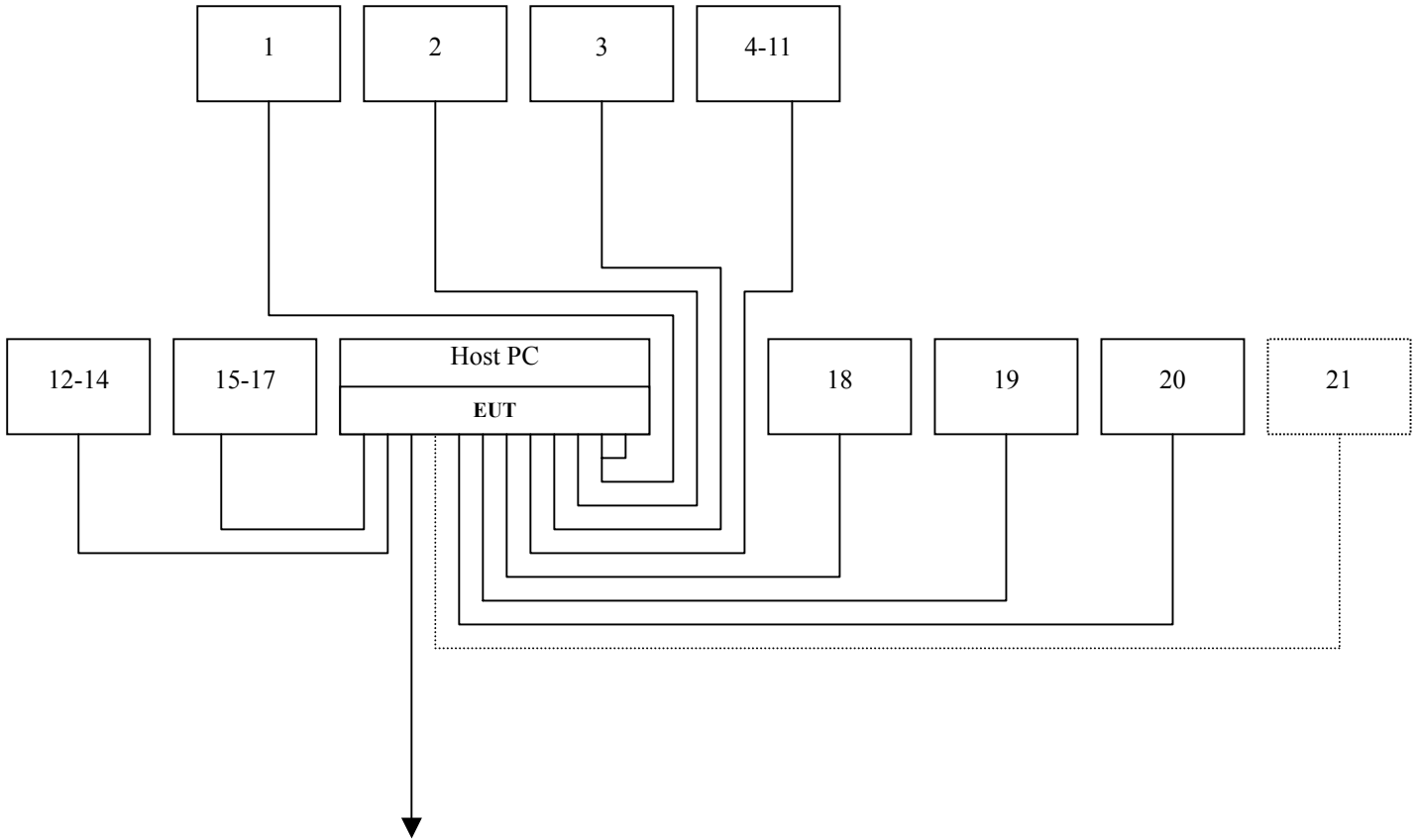



## 5 FACILITIES AND ACCREDITATIONS

### 5.1. FACILITIES

All measurement facilities (exclude facilities of measurement radiated frequency above 1GHz) used to collect the measurement data are located at CCS Taiwan Sindian BU. at No.163-1, Jhongsheng Rd., Sindian City, Taipei County 23151, Taiwan.

The measurement facilities of radiated frequency rang above 1GHz are located at CCS Taiwan Linkou BU. at No.81-1, Lane 210, Bade 2nd Rd., Lujhu Township, Taoyuan County 33841, Taiwan Taoyuan Hsien, Taiwan.

The sites are constructed in conformance with the requirements of ANSI C63.4 and CISPR Publication 22. All receiving equipment conforms to CISPR 16-1-1, CISPR 16-1-2, CISPR 16-1-3, CISPR 16-1-4 and CISPR 16-1-5.

### 5.2. ACCREDITATIONS

Our laboratories are accredited and approved by the following accreditation body according to ISO/IEC 17025.

<b>Taiwan</b>	TAF
<b>USA</b>	A2LA

The measuring facility of laboratories has been authorized or registered by the following approval agencies.

<b>Canada</b>	Industry Canada
<b>Norway</b>	Nemko
<b>Japan</b>	VCCI
<b>Taiwan</b>	BSMI
<b>USA</b>	FCC

Copies of granted accreditation certificates are available for downloading from our web site, <http://www.ccsrf.com>

### 5.3. MEASUREMENT UNCERTAINTY

Where relevant, the following measurement uncertainty levels have been estimated for tests performed on the EUT as specified in CISPR 16-4-2:

Measurement	Frequency	Uncertainty
Conducted emissions	0.15MHz~30MHz	± 1.7376
Radiated emissions	30MHz ~1000MHz	± 3.97

This uncertainty represents an expanded uncertainty expressed at approximately the 95% confidence level using a coverage factor of k=2.

Consistent with industry standard (e.g. CISPR 22: 2005, clause 11, Measurement Uncertainty) determining compliance with the limits shall be base on the results of the compliance measurement. Consequently the measure emissions being less than the maximum allowed emission result in this be a compliant test or passing test.

The acceptable measurement uncertainty value without requiring revision of the compliance statement is base on conducted and radiated emissions being less than  $U_{CISPR}$  which is 3.6dB and 5.2dB respectively. CCS values (called  $U_{Lab}$  in CISPR 16-4-2) is less than  $U_{CISPR}$  as shown in the table above. Therefore, MU need not be considered for compliance.



## 6 CONDUCTED EMISSION MEASUREMENT

### 6.1. LIMITS OF CONDUCTED EMISSION MEASUREMENT

FREQUENCY (MHz)	Class A (dBuV)		Class B (dBuV)	
	Quasi-peak	Average	Quasi-peak	Average
0.15 - 0.5	79	66	66 - 56	56 - 46
0.50 - 5.0	73	60	56	46
5.0 - 30.0	73	60	60	50

**NOTE:**

- (1) The lower limit shall apply at the transition frequencies.
- (2) The limit decreases in line with the logarithm of the frequency in the range of 0.15 to 0.50 MHz.
- (3) All emanations from a class A/B digital device or system, including any network of conductors and apparatus connected thereto, shall not exceed the level of field strengths specified above.

### 6.2. TEST INSTRUMENTS

Conducted Emission Room # A				
Name of Equipment	Manufacturer	Model	Serial Number	Calibration Due
TEST RECEIVER	R&S	ESHS20	840455/006	02/12/2010
LISN (EUT)	SCHWARZBECK	NSLK 8127	8127382	12/09/2009
LISN	SOLAR	8012-50-R-24-BNC	8305114	12/09/2009
BNC CABLE	MIYAZAKI	5D-FB	BNC A4	05/11/2010
THERMO-HYGRO METER	TECPEL	DTM-303	No.7	11/24/2009
Test S/W	EMI 32.exe			

- NOTE:** 1. The calibration interval of the above test instruments is 12 months and the calibrations are traceable to NML/ROC and NIST/USA.  
2. N.C.R = No Calibration Request.



### **6.3. TEST PROCEDURES** (please refer to measurement standard or CCS SOP PA-031)

#### **Procedure of Preliminary Test**

- The EUT and Support equipment, if needed, was set up as per the test configuration to simulate typical usage per the user's manual. When the EUT is a tabletop system, a wooden table with a height of 0.8 meters is used and is placed on the ground plane as per ANSI C63.4 (see Test Facility for the dimensions of the ground plane used). When the EUT is a floor standing equipment, it is placed on the ground plane, which has a 12 mm non-conductive covering to insulate the EUT from the ground plane.
- All I/O cables were positioned to simulate typical actual usage as per ANSI C63.4.
- The test equipment EUT installed received AC main power, through a Line Impedance Stabilization Network (LISN), which supplied power source and was grounded to the ground plane.
- All support equipment power received from a second LISN.
- The EUT test program was started. Emissions were measured on each current carrying line of the EUT using an EMI Test Receiver connected to the LISN powering the EUT.
- The Receiver scanned from 150kHz to 30MHz for emissions in each of the test modes.
- During the above scans, the emissions were maximized by cable manipulation.
- The test mode(s) described in Item 3.1 were scanned during the preliminary test.
- After the preliminary scan, we found the test mode described in Item 3.1 producing the highest emission level.
- The EUT configuration and cable configuration of the above highest emission levels were recorded for reference of the final test.

#### **Procedure of Final Test**

- EUT and support equipment were set up on the test bench as per the configuration with highest emission level in the preliminary test.
- A scan was taken on both power lines, Line 1 and Line 2, recording at least the six highest emissions. Emission frequency and amplitude were recorded into a computer in which correction factors were used to calculate the emission level and compare reading to the applicable limit.
- The test data of the worst-case condition(s) was recorded.

**6.4. TEST SETUP**

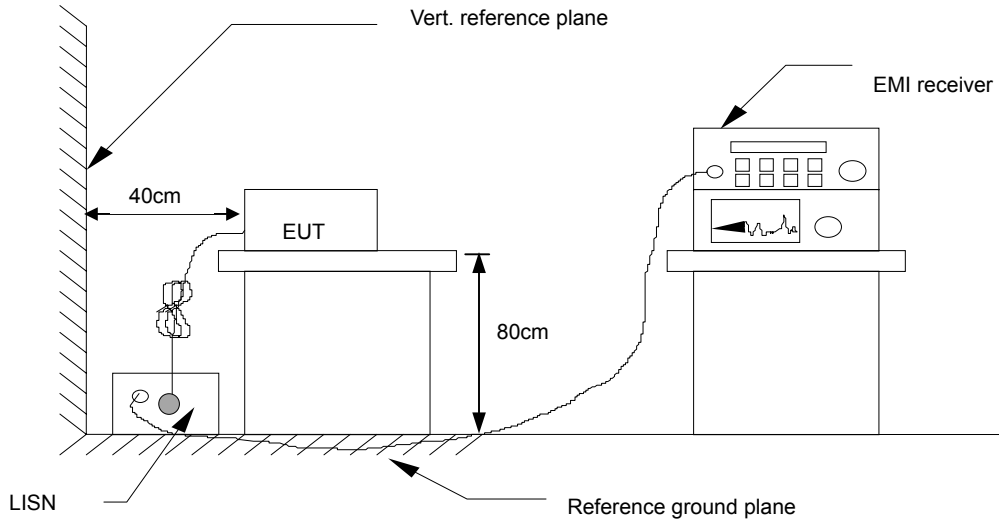

- For the actual test configuration, please refer to the related item – Photographs of the Test Configuration.

**6.5. DATA SAMPLE**

Freq. (MHz)	Read Level (dBuV)	Factor (dB)	Level (dBuV)	Limit Line (dBuV)	Over Limit (dB)	Remark (P/Q/A)	Line (L1/L2)
x.xx	42.95	0.55	43.50	73	-29.50	Q	L1

- Freq. = Emission frequency in MHz
- Read Level = Uncorrected Analyzer/Receiver reading
- Factor = Insertion loss of LISN + Cable Loss
- Level = Read Level + Factor
- Limit Line = Limit stated in standard
- Over Limit = Reading in reference to limit
- P = Peak Reading
- Q = Quasi-peak Reading
- A = Average Reading
- L1 = Hot side
- L2 = Neutral side

**Calculation Formula**

Over Limit (dB) = Level (dBuV) – Limit Line (dBuV)



**6.6. TEST RESULTS**

<b>Model No.</b>	EMB-9459T	<b>6dB Bandwidth</b>	10 KHz
<b>Environmental Conditions</b>	24°C, 58% RH, 1010mbar	<b>Test Mode</b>	Mode 2
<b>Tested by</b>	BENSON YANG		

(The chart below shows the highest readings taken from the final data.)

<b>Six Highest Conducted Emission Readings</b>							
<b>Frequency Range Investigated</b>				<b>150 KHz to 30 MHz</b>			
<b>Freq. (MHz)</b>	<b>Read Level (dBuV)</b>	<b>Factor (dB)</b>	<b>Level (dBuV)</b>	<b>Limit Line (dBuV)</b>	<b>Over Limit (dB)</b>	<b>Remark (P/Q/A)</b>	<b>Line (L1/L2)</b>
<b>9.156</b>	<b>36.14</b>	<b>0.58</b>	<b>36.73</b>	<b>73.00</b>	<b>-36.27</b>	<b>P</b>	<b>L1</b>
<b>13.841</b>	<b>38.25</b>	<b>0.86</b>	<b>39.11</b>	<b>73.00</b>	<b>-33.89</b>	<b>P</b>	<b>L1</b>
<b>15.307</b>	<b>37.87</b>	<b>0.94</b>	<b>38.81</b>	<b>73.00</b>	<b>-34.19</b>	<b>P</b>	<b>L1</b>
<b>9.654</b>	<b>34.17</b>	<b>0.48</b>	<b>34.65</b>	<b>73.00</b>	<b>-38.35</b>	<b>P</b>	<b>L2</b>
<b>14.288</b>	<b>35.23</b>	<b>0.69</b>	<b>35.92</b>	<b>73.00</b>	<b>-37.08</b>	<b>P</b>	<b>L2</b>
<b>15.718</b>	<b>37.02</b>	<b>0.76</b>	<b>37.78</b>	<b>73.00</b>	<b>-35.22</b>	<b>P</b>	<b>L2</b>

NOTE: 1. L1 = Line One (Live Line) / L2 = Line Two (Neutral Line).

2. The emission level was or more than 2dB below the Average limit, so no re-check anymore.



## 7 RADIATED EMISSION MEASUREMENT

### 7.1. LIMITS OF RADIATED EMISSION MEASUREMENT

FREQUENCY (MHz)	dBuV/m (At 10m)	
	Class A	Class B
30 ~ 230	40	30
230 ~ 1000	47	37

Frequency (MHz)	Class A (dBuV/m) (At 3m)		Class B (dBuV/m) (At 3m)	
	Average	Peak	Average	Peak
Above 1000	60	80	54	74

**NOTE:** (1) The lower limit shall apply at the transition frequencies.  
 (2) Emission level (dBuV/m) = 20 log Emission level (uV/m).  
 (3) 10m to 3m: 20 log (3/10)=-10.4576dB.

### 7.2. TEST INSTRUMENTS

Open Area Test Site # I				
Name of Equipment	Manufacturer	Model	Serial Number	Calibration Due
MEASURE RECEIVER	SCHAFFNER	SCR3501	338	07/07/2010
SPECTRUM ANALYZER	ADVANTEST	R3132	120900008	No Calibration Required
ANTENNA	SCHAFFNER	CBL 6112B	2809	09/06/2010
AMPLIFIER	SCHAFFNER	CPA9231A	3626	10/11/2010
CABLE	BELDEN	9913	N-TYPE #I2	02/21/2011
THERMO-HYGRO METER	TECPEL	DTM-303	090639	05/23/2011
Test S/W	EZ-EMC			
Above 1GHz Used				
Spectrum Analyzer	Agilent	E4407B	MY44212679	12/28/2009
Bilog Antenna	SCHWAZBECK	VULB9160	3084	09/11/2010
EMI Test Receiver	SCHAFFNER	SCR 3501	436	01/21/2010
Pre-Amplifier	HP	8447D	2944A06530	12/31/2009
Turn Table	CCS	CC-T-1F	N/A	N.C.R
Antenna Tower	CCS	CC-A-1F	N/A	N.C.R
Controller	CCS	CC-C-1F	N/A	N.C.R
Site NSA	SIDT EUROPE	9x6x6	N/A	05/15/2010
Test S/W	CCS-3A1RE			

**NOTE:** 1. The calibration interval of the above test instruments is 12 months and the calibrations are traceable to NML/ROC and NIST/USA.  
 2. N.C.R = No Calibration Request.



### **7.3. TEST PROCEDURES** (please refer to measurement standard or CCS SOP PA-031)

#### **Procedure of Preliminary Test**

- The equipment was set up as per the test configuration to simulate typical usage per the user's manual. When the EUT is a tabletop system, a wooden turntable with a height of 0.8 meters is used which is placed on the ground plane. When the EUT is a floor standing equipment, it is placed on the ground plane which has a 12 mm non-conductive covering to insulate the EUT from the ground plane.
- Support equipment, if needed, was placed as per ANSI C63.4.
- All I/O cables were positioned to simulate typical usage as per ANSI C63.4.
- The EUT received AC power source from the outlet socket under the turntable. All support equipment power received from another socket under the turntable.
- The antenna was placed at 3 or 10 meter way from the EUT as stated in ANSI C63.4. The antenna connected to the Spectrum Analyzer via a cable and at times a pre-amplifier would be used.
- The Analyzer / Receiver quickly scanned from 30MHz to 40GHz. The EUT test program was started. Emissions were scanned and measured rotating the EUT to 360 degrees and positioning the antenna 1 to 4 meters above the ground plane, in both the vertical and the horizontal polarization, to maximize the emission reading level.
- The test mode(s) described in Item 3.1 were scanned during the preliminary test:
- After the preliminary scan, we found the test mode described in Item 3.1 producing the highest emission level.
- The EUT and cable configuration, antenna position, polarization and turntable position of the above highest emission level were recorded for the final test.

**Procedure of Final Test**

- EUT and support equipment were set up on the turntable as per the configuration with highest emission level in the preliminary test.
- The Analyzer / Receiver scanned from 30MHz to 40GHz. Emissions were scanned and measured rotating the EUT to 360 degrees, varying cable placement and positioning the antenna 1 to 4 meters above the ground plane, in both the vertical and the horizontal polarization, to maximize the emission reading level.
- Recorded at least the six highest emissions. Emission frequency, amplitude, antenna position, polarization and turntable position were recorded into a computer in which correction factors were used to calculate the emission level and compare reading to the applicable limit and only Q.P. reading is presented.
- The test data of the worst-case condition(s) was recorded.

**7.4. TEST SETUP**

- For the actual test configuration, please refer to the related item – Photographs of the Test Configuration.

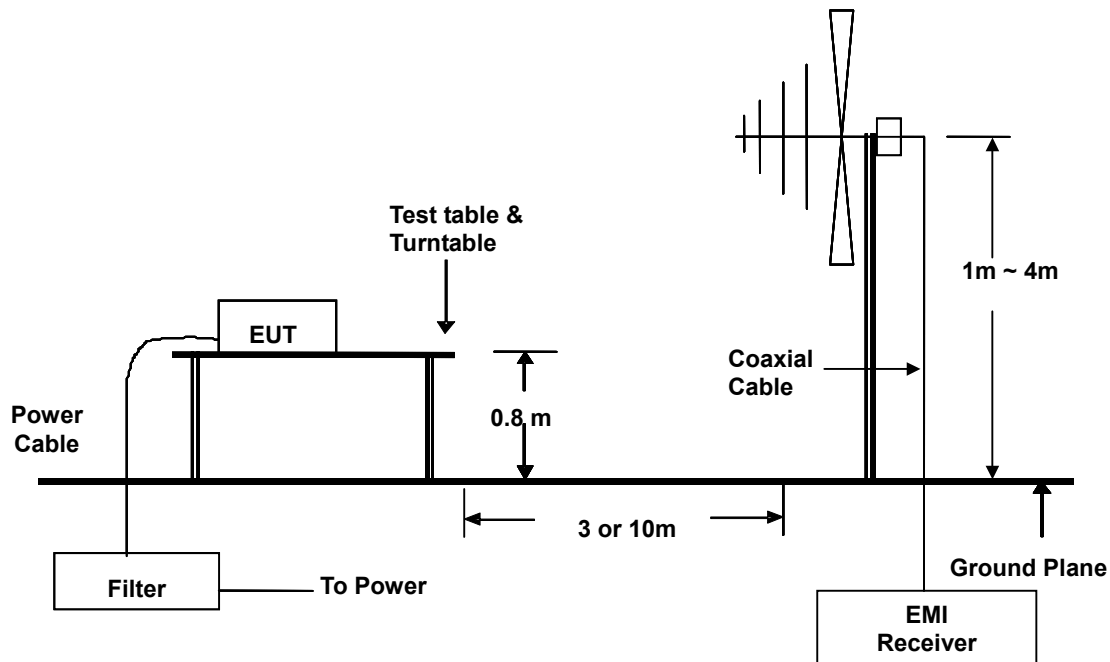





7.5. DATA SAMPLE

Below 1GHz

Freq. (MHz)	Reading (dBuV)	Factor (dB/m)	Result (dBuV/m)	Limit (dBuV/m)	Margin (dB)	Detector (P/Q)	Pol. (H/V)
x.xx	14.0	12.2	26.2	40	-13.8	Q	H

Above 1GHz

Freq. (MHz)	Reading (dBuV)	Factor (dB/m)	Result (dBuV/m)	Limit (dBuV/m)	Margin (dB)	Detector (P/Q)	Pol. (H/V)
x.xx	42.95	0.55	43.50	60	-16.50	A	H

- Freq. = Emission frequency in MHz
- Reading = Uncorrected Analyzer/Receiver reading
- Factor = Antenna Factor + Cable Loss - Amplifier Gain
- Result = Reading + Factor
- Limit = Limit stated in standard
- Margin = Reading in reference to limit
- P = Peak Reading
- Q = Quasi-peak Reading
- A = Average Reading
- H = Antenna Polarization: Horizontal
- V = Antenna Polarization: Vertical

**Calculation Formula**

Margin (dB) = Result (dBuV/m) – Limit (dBuV/m)

## 7.6. TEST RESULTS

### Below 1GHz

<b>Model No.</b>	EMB-9459T	<b>Test Mode</b>	Mode 3
<b>Environmental Conditions</b>	22°C, 85% RH, 1010mbar	<b>6dB Bandwidth</b>	120 KHz
<b>Antenna Pole</b>	Vertical & Horizontal	<b>Antenna Distance</b>	10m
<b>Detector Function</b>	Quasi-peak.	<b>Tested by</b>	HOWARD PANG

(The chart below shows the highest readings taken from the final data.)

Six Highest Radiated Emission Readings							
Frequency Range Investigated				30 MHz to 1000 MHz at 10m			
Freq. (MHz)	Reading (dBuV)	Factor (dB/m)	Result (dBuV/m)	Limit (dBuV/m)	Margin (dB)	Detector (P/Q)	Pol. (H/V)
79.9070	53.10	-21.16	31.94	40.00	-8.06	Q	V
186.4800	48.90	-17.98	30.92	40.00	-9.08	Q	V
239.9900	54.80	-15.70	39.10	47.00	-7.90	Q	V
433.3380	47.00	-9.40	37.60	47.00	-9.40	Q	V
480.0400	45.20	-8.20	37.00	47.00	-10.00	Q	V
500.0100	49.60	-7.70	41.90	47.00	-5.10	Q	V

Six Highest Radiated Emission Readings							
Frequency Range Investigated				30 MHz to 1000 MHz at 10m			
Freq. (MHz)	Reading (dBuV)	Factor (dB/m)	Result (dBuV/m)	Limit (dBuV/m)	Margin (dB)	Detector (P/Q)	Pol. (H/V)
166.6700	52.60	-17.70	34.90	40.00	-5.10	Q	H
239.9600	58.90	-15.70	43.20	47.00	-3.80	Q	H
480.0500	48.50	-8.19	40.31	47.00	-6.69	Q	H
500.0300	52.00	-7.70	44.30	47.00	-2.70	Q	H
766.6900	39.10	-4.14	34.96	47.00	-12.04	Q	H
1000.000	39.50	-1.09	38.41	47.00	-8.59	Q	H

- Note:**
1. 30MHz to 1000MHz test is Applicable CISPR 22 / EN 55022 standard.
  2. The other emission levels were very low against the limit.
  3. P= Peak Reading; Q= Quasi-peak Reading



Above 1GHz

<b>Model No.</b>	EMB-9459T	<b>Test Mode</b>	Mode 2
<b>Environmental Conditions</b>	18°C, 60% RH, 1010mbar	<b>6dB Bandwidth</b>	1000 KHz
<b>Antenna Pole</b>	Vertical & Horizontal	<b>Antenna Distance</b>	3m
<b>Detector Function</b>	Quasi-peak.	<b>Tested by</b>	TONY TASI

(The chart below shows the highest readings taken from the final data.)

<b>Six Highest Radiated Emission Readings</b>							
<b>Frequency Range Investigated</b>				<b>1000 MHz to 8000 MHz at 3m</b>			
Freq. (MHz)	Reading (dBuV)	Factor (dB/m)	Result (dBuV/m)	Limit (dBuV/m)	Margin (dB)	Detector (P/Q)	Pol. (H/V)
1025.000	48.06	-9.47	38.59	74.00	-35.41	P	V
1300.000	46.71	-7.90	38.81	74.00	-35.19	P	V
1400.000	46.33	-7.32	39.01	74.00	-34.99	P	V
1537.500	45.84	-6.52	39.32	74.00	-34.68	P	V
1712.500	52.87	-5.44	47.43	74.00	-26.57	P	V
2462.500	48.88	-2.05	46.83	74.00	-27.17	P	V

<b>Six Highest Radiated Emission Readings</b>							
<b>Frequency Range Investigated</b>				<b>1000 MHz to 8000 MHz at 3m</b>			
Freq. (MHz)	Reading (dBuV)	Factor (dB/m)	Result (dBuV/m)	Limit (dBuV/m)	Margin (dB)	Detector (P/Q)	Pol. (H/V)
1350.020	47.04	-7.61	39.43	74.00	-34.57	P	H
1425.000	47.55	-7.18	40.37	74.00	-33.63	P	H
1463.380	47.50	-6.96	40.54	74.00	-33.46	P	H
1612.500	51.02	-6.05	44.97	74.00	-29.03	P	H
2375.000	48.89	-2.35	46.54	74.00	-27.46	P	H
2462.500	50.95	-2.05	48.90	74.00	-25.10	P	H

- Note:**
1. The other emission levels were very low against the limit.
  2. P= Peak Reading; A= Average Reading.

## 8 PHOTOGRAPHS OF THE TEST CONFIGURATION CONDUCTED EMISSION TEST





### RADIATED EMISSION TEST

