

FCC DoC TEST REPORT

for

Robust Panel PC

MODEL: xxxxxAPC-9172HTy-xx-xxxx

Test Report Number:
70427205-F

Issued to:

AAEON Technology Inc.

**5F, No.135, Lane 235, Pao Chiao Rd., Hsin-Tien City,
Taipei, Taiwan, R.O.C.**

Issued by:

Compliance Certification Services Inc.

Sindian BU

**No.163-1, Jhongsheng Rd., Sindian City,
Taipei County 23151, Taiwan**

TEL: 886-2-22170894

FAX: 886-2-22171029

Issued Date: May 4, 2007



Note: This report shall not be reproduced except in full, without the written approval of Compliance Certification Services Inc. This document may be altered or revised by Compliance Certification Services Inc. personnel only, and shall be noted in the revision section of the document. The client should not use it to claim product endorsement by TAF, A2LA, NVLAP, NIST or any government agencies. The test results in the report only apply to the tested sample.



Revision History

Rev.	Issue Date	Revisions	Effect Page	Revised By
00		Initial Issue	ALL	



TABLE OF CONTENTS

1 TEST RESULT CERTIFICATION4

2 EUT DESCRIPTION5

3 TEST METHODOLOGY.....6

3.1. DECISION OF FINAL TEST MODE6

3.2. EUT SYSTEM OPERATION6

4 SETUP OF EQUIPMENT UNDER TEST.....7

4.1. DESCRIPTION OF SUPPORT UNITS7

4.2. CONFIGURATION OF SYSTEM UNDER TEST9

5 FACILITIES AND ACCREDITATIONS.....10

5.1. FACILITIES10

5.2. ACCREDITATIONS.....10

5.3. MEASUREMENT UNCERTAINTY10

6 CONDUCTED EMISSION MEASUREMENT.....11

6.1. LIMITS OF CONDUCTED EMISSION MEASUREMENT11

6.2. TEST INSTRUMENTS11

6.3. TEST PROCEDURES12

6.4. TEST SETUP13

6.5. DATA SAMPLE13

6.6. TEST RESULTS14

7 RADIATED EMISSION MEASUREMENT.....15

7.1. LIMITS OF RADIATED EMISSION MEASUREMENT15

7.2. TEST INSTRUMENTS15

7.3. TEST PROCEDURES16

7.4. TEST SETUP18

7.5. DATA SAMPLE18

7.6. TEST RESULTS19

8 PHOTOGRAPHS OF THE TEST CONFIGURATION21



1 TEST RESULT CERTIFICATION

Product: Robust Panel PC

Model: xxxxxAPC-9172HTy-xx-xxxx(Where y is T or blank and x is 0-9, A-Z, - or blank)

Brand: AAEON

Applicant: **AAEON Technology Inc.**
5F, No.135, Lane 235, Pao Chiao Rd., Hsin-Tien City,
Taipei, Taiwan, R.O.C.

Manufacturer: **AAEON Technology Inc.**
5F, No.135, Lane 235, Pao Chiao Rd., Hsin-Tien City,
Taipei, Taiwan, R.O.C.

Tested: April 27, 2007 & May 2, 2007

EMISSION			
Standard	Item	Result	Remarks
FCC 47 CFR Part 15 Subpart B, ICES-003 Issue 4 ANSI C63.4-2003	Conducted (Main Port)	PASS	Meet Class A limit
	Radiated	PASS	Meet Class A limit

Note: 1. The test result judgment is decided by the limit of measurement standard.
2. The information of measurement uncertainty is available upon the customer's request.

Deviation from Applicable Standard
None



The above equipment has been tested by Compliance Certification Services Inc., and found compliance with the requirements set forth in the technical standards mentioned above. The results of testing in this report apply only to the product/system, which was tested. Other similar equipment will not necessarily produce the same results due to production tolerance and measurement uncertainties.

Approved by:

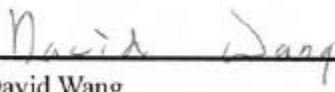
Reviewed by:



 David Wang
 Manager of Sindian BU

 Vince Chiang
 Assistant Manager of Sindian BU



2 EUT DESCRIPTION

Product	Robust Panel PC
Brand Name	AAEON
Model	xxxxxAPC-9172HTy-xx-xxxx(Where y is T or blank and x is 0-9, A-Z, - or blank)
Test Item	Engineering Sample
Applicant	AAEON Technology Inc.
Housing material	Metal Case
EUT Type	<input checked="" type="checkbox"/> Engineering Sample . <input type="checkbox"/> Product Sample . <input type="checkbox"/> Mass Product Sample.
Serial Number	N/A
Received Date	April 27, 2007
EUT Power Rating	100-240VAC, 50-60Hz
AC Power During Test	120VAC / 60Hz
Power Supply Manufacturer	FSP
Power Supply Model Number	FSP250-50PLB
OSC/Clock Frequencies	14.31818MHz; 25MHz; 32.768KHz

I/O PORT

I/O PORT TYPES	Q' TY	TESTED WITH
1. PIO Port	1	1
2. SIO Port	4	4
3. PS/2 Keyboard Port	1	1
4. PS/2 Mouse Port	1	1
5. Video Out Port (VGA)	1	1
6. Audio In Port	1	1
7. Microphone Port	1	1
8. Earphone Port	1	1
9. LAN Port	2	2
10. USB Port	5	5
11. CF/ SM/ MS/ SD Slot	1/ 1/ 1/ 1	1/ 1/ 1/ 1

Note: Client consigns only one model sample to test (Model Number: APC-9172).



3 TEST METHODOLOGY

3.1. DECISION OF FINAL TEST MODE

The EUT was tested together with the above additional components, and a configuration, which produced the worst emission levels, was selected and recorded in this report.

The test configuration/ mode is as the following:

Conduction:

1.	Normal Mode
----	-------------

Radiation(s):

1.	Normal Mode
	Normal Mode / 1-8.3GHz

Conduction: Mode 1

Radiation: Mode 1

3.2. EUT SYSTEM OPERATION

1. Windows XP boots system.
2. Run Emctest.exe to activate all peripherals and display “H” pattern on monitor screen.
3. Run media player to play music.
4. Run Winemc.exe and choose “E:/ & F:/ & G:/ & H:/ & I:/ & J:/ & K:/ & L:/ & N:/” to test EUT.
5. Press the start menu, select executive and type ping 192.168.0.2-t (EUT), ping 192.168.0.1 -t (Server Notebook).
6. Press the start menu, select executive and type ping 192.168.1.2-t (EUT), ping 192.168.1.1 -t (Server Notebook).

Note: Test program is self-repeating throughout the test.



4 SETUP OF EQUIPMENT UNDER TEST

4.1. DESCRIPTION OF SUPPORT UNITS

The EUT has been tested as an independent unit together with other necessary accessories or support units. The following support units or accessories were used to form a representative test configuration during the tests.

EUT Devices:

No.	Equipment	Model No.	Trade Name
1	RAM (512MB / DDR2)	E5108A G-6E-E	ELPIDA
2	CPU (1.66GHz)	T5500	Intel(R)Core 2
3	SATA HDD (80GB)	MHV2080BH	FUJITSU
4	Power Supply	FSP250-50PLB	FSP
5	DVD ROM	DV-28SL-R93	TEAC

**Peripherals Devices:**

No.	Equipment	Model No.	Serial No.	FCC ID/ BSMI ID	Trade Name	Data Cable	Power Cord
1	Earphone & Microphone	MSB301	N/A	N/A	e-Sense	Unshielded, 1.8m	N/A
2	Player	RQ-L11LT	N/A	BSMI ID: 3912A162	Panasonic	Unshielded, 1.4m	N/A
3	USB HDD	F12-U	N/A	BSMI ID: 4912A002	TeraSys	Shielded, 1.8m	N/A
4	PS/2 Mouse	M071KC	443029438	DOC / BSMI: R41108	DELL	Shielded, 1.8m	N/A
5	PS/2 Keyboard	SK-8110	N/A	DOC / BSMI: T3A002	DELL	Shielded, 1.8m	N/A
6	USB HDD	F12-U	N/A	BSMI ID: 4912A002	TeraSys	Shielded, 1.8m	N/A
7	USB HDD	F12-U	N/A	BSMI ID: 4912A002	TeraSys	Shielded, 1.8m	N/A
8	USB HDD	F12-U	N/A	BSMI ID: 4912A002	TeraSys	Shielded, 1.8m	N/A
9	USB HDD	F12-U	N/A	BSMI ID: 4912A002	TeraSys	Shielded, 1.8m	N/A
10	Printer	C60	N/A	BSMI ID: 3902E006	EPSON	Shielded, 1.8m	Unshielded, 1.8m
11	Monitor	710V	GS17H9NXA05855D	DOC / BSMI: R33475	SAMSUNG	Shielded, 1.8m with two cores	Unshielded, 1.8m
12	Modem	5JEG4033MKO	N/A	5RJTAI-35500-M5-E	TOP-SOLUTION	Shielded, 1.6m	Unshielded, 1.8m
13	Modem	1414	N/A	IFAXDM1414	ACEEX	Shielded, 1.6m	Unshielded, 1.8m
14	Modem	1414	N/A	IFAXDM1414	ACEEX	Shielded, 1.6m	Unshielded, 1.8m
15	Modem	1414	N/A	IFAXDM1414	ACEEX	Shielded, 1.6m	Unshielded, 1.8m
16	Server Notebook	M623	N/A	N/A	Fox	Unshielded, 20m	Unshielded, 1.8m
17	Server Notebook	PP05L	2464936188	DOC / BSMI: R33002	DELL	Unshielded, 20m	Unshielded, 1.8m
18	CF Card	N/A	N/A	N/A	N/A	N/A	N/A
19	SD Card	N/A	N/A	N/A	N/A	N/A	N/A
20	MS Card	N/A	N/A	N/A	N/A	N/A	N/A
21	SM Card	N/A	N/A	N/A	N/A	N/A	N/A

Note:

- 1) All the equipment/cables were placed in the worst-case configuration to maximize the emission during the test.
- 2) Grounding was established in accordance with the manufacturer's requirements and conditions for the intended use.

4.2. CONFIGURATION OF SYSTEM UNDER TEST

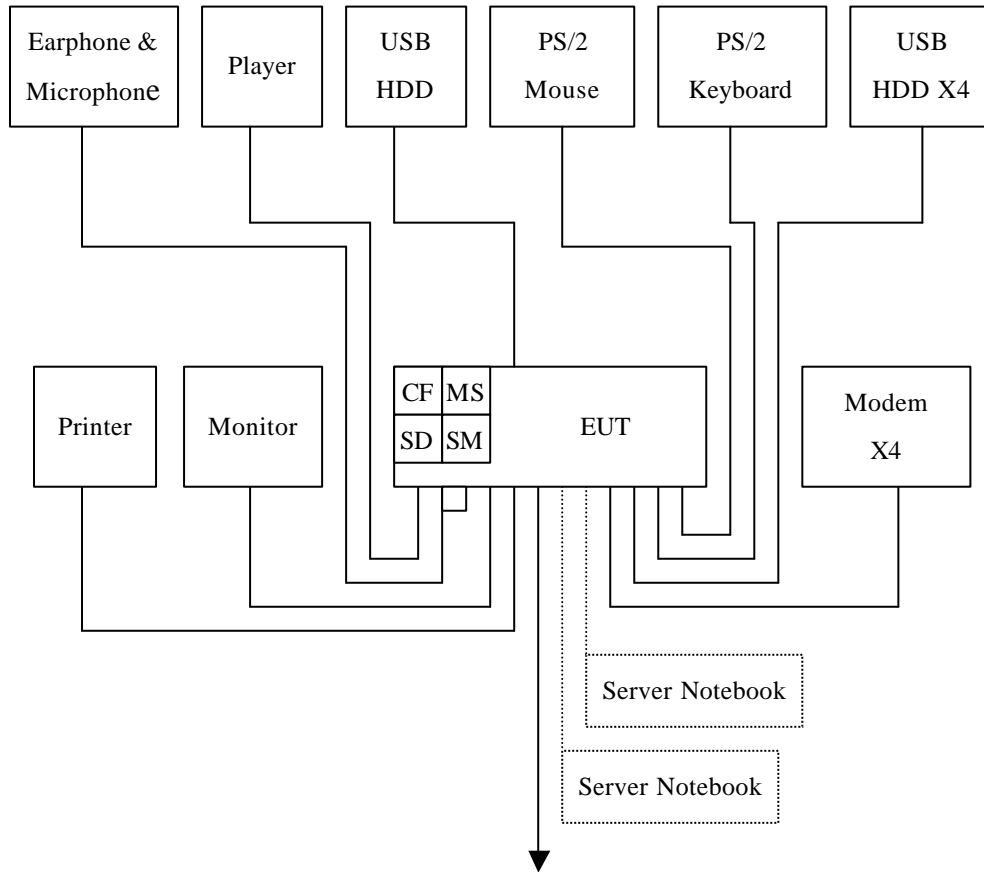

5 FACILITIES AND ACCREDITATIONS

5.1. FACILITIES

All measurement facilities used to collect the measurement data are located at CCS Taiwan Sindian BU at No.163-1, Jhongsheng Rd., Sindian City, Taipei County 23151, Taiwan.

The sites are constructed in conformance with the requirements of ANSI C63.4 and CISPR Publication 22. All receiving equipment conforms to CISPR Publication 16-1, "Radio Interference Measuring Apparatus and Measurement Methods."

5.2. ACCREDITATIONS

Our laboratories are accredited and approved by the following approval agencies according to ISO/IEC 17025.

USA	FCC, A2LA,
Germany	TUV Rheinland
Japan	VCCI
Norway	NEMKO
Canada	INDUSTRY CANADA
Taiwan	TAF, BSMI

Copies of granted accreditation certificates are available for downloading from our web site, <http://www.ccsemc.com.tw>

5.3. MEASUREMENT UNCERTAINTY

Where relevant, the following measurement uncertainty levels have been estimated for tests performed on the EUT as specified in CISPR 16-4-2:

Measurement	Frequency		Uncertainty
Conducted emissions	9kHz~30MHz		± 3.4508
Radiated emissions	Horizontal	30MHz ~ 200MHz	± 4.3799
		200MHz ~1000MHz	± 4.5147
	Vertical	30MHz ~ 200MHz	± 4.5015
		200MHz ~1000MHz	± 4.5073

This uncertainty represents an expanded uncertainty expressed at approximately the 95% confidence level using a coverage factor of k=2.



6 CONDUCTED EMISSION MEASUREMENT

6.1. LIMITS OF CONDUCTED EMISSION MEASUREMENT

FREQUENCY (MHz)	Class A (dBuV)		Class B (dBuV)	
	Quasi-peak	Average	Quasi-peak	Average
0.15 - 0.5	79	66	66 - 56	56 - 46
0.50 - 5.0	73	60	56	46
5.0 - 30.0	73	60	60	50

NOTE:

- (1) The lower limit shall apply at the transition frequencies.
- (2) The limit decreases in line with the logarithm of the frequency in the range of 0.15 to 0.50 MHz.
- (3) All emanations from a class A/B digital device or system, including any network of conductors and apparatus connected thereto, shall not exceed the level of field strengths specified above.

6.2. TEST INSTRUMENTS

Conducted Emission room # A				
Name of Equipment	Manufacturer	Model	Serial Number	Calibration Due
TEST RECEIVER	R&S	ESHS20	840455/006	02/12/2008
LISN (EUT)	SCHWARZBECK	NSLK 8127	8127382	12/06/2007
LISN	SOLAR	8012-50-R-24-BNC	8305114	12/26/2007
BNC CABLE	JYE BAO	RG-223/U	BNC A2	10/10/2007
THERMO-HYGRO METER	TOP	HA-202	9303-1	02/04/2008
Test S/W	EMI 32.exe			

- NOTE:** 1. The calibration interval of the above test instruments is 12 months and the calibrations are traceable to NML/ROC and NIST/USA.
 2. N.C.R = No Calibration Request.



6.3. TEST PROCEDURES (please refer to measurement standard or CCS SOP PA -031)

Procedure of Preliminary Test

- The EUT and Support equipment, if needed, was set up as per the test configuration to simulate typical usage per the user's manual. When the EUT is a tabletop system, a wooden table with a height of 0.8 meters is used and is placed on the ground plane as per ANSI C63.4 (see Test Facility for the dimensions of the ground plane used). When the EUT is a floor standing equipment, it is placed on the ground plane, which has a 3-12 mm non-conductive covering to insulate the EUT from the ground plane.
- All I/O cables were positioned to simulate typical actual usage as per ANSI C63.4.
- The test equipment EUT installed received AC main power, through a Line Impedance Stabilization Network (LISN), which supplied power source and was grounded to the ground plane.
- All support equipment power received from a second LISN.
- The EUT test program was started. Emissions were measured on each current carrying line of the EUT using an EMI Test Receiver connected to the LISN powering the EUT.
- The Receiver scanned from 150kHz to 30MHz for emissions in each of the test modes.
- During the above scans, the emissions were maximized by cable manipulation.
- The test mode(s) described in Item 3.1 were scanned during the preliminary test.
- After the preliminary scan, we found the test mode described in Item 3.1 producing the highest emission level.
- The EUT configuration and cable configuration of the above highest emission levels were recorded for reference of the final test.

Procedure of Final Test

- EUT and support equipment were set up on the test bench as per the configuration with highest emission level in the preliminary test.
- A scan was taken on both power lines, Line 1 and Line 2, recording at least the six highest emissions. Emission frequency and amplitude were recorded into a computer in which correction factors were used to calculate the emission level and compare reading to the applicable limit.
- The test data of the worst-case condition(s) was recorded.

6.4. TEST SETUP

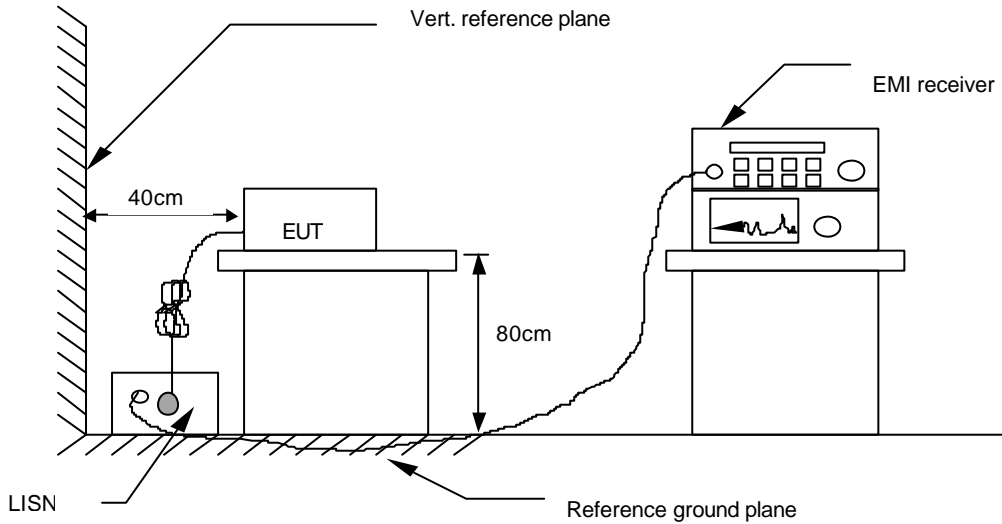

- For the actual test configuration, please refer to the related item – Photographs of the Test Configuration.

6.5. DATA SAMPLE

Freq. MHz	Read Level dBuV	Factor dB	Level dBuV	Limit dBuV	Over Limit dB	Reading Type (P/Q/A)	Line (L1/L2)
x.xx	42.95	0.55	43.50	73	-29.50	Q	L1

- Freq. = Emission frequency in MHz
- Read Level = Uncorrected Analyzer/Receiver reading
- Factor = Insertion loss of LISN + Cable Loss
- Level = Read Level + Factor
- Limit = Limit stated in standard
- Over Limit = Reading in reference to limit
- P = Peak Reading
- Q = Quasi-peak Reading
- A = Average Reading
- L1 = Hot side
- L2 = Neutral side

Calculation Formula

Over Limit (dB) = Level (dBuV) – Limit (dBuV)



6.6. TEST RESULTS

Model No.	APC-9172	6dB Bandwidth	10 KHz
Environmental Conditions	25deg.C, 55% RH, 1010 hPa	Test Mode	Mode 1
Tested by	James Hsieh		

(The chart below shows the highest readings taken from the final data.)

Six Highest Conducted Emission Readings							
Frequency Range Investigated				150 KHz to 30 MHz			
Freq (MHz)	Read Level (dBuV)	Factor (dB)	Level (dBuV)	Limit Line (dBuV)	Over Limit (dB)	Reading Type (P/Q/A)	Line (L1/L2)
6.627	42.0	0.99	43.08	73.00	-29.92	P	L1
11.438	42.39	1.21	43.60	73.00	-29.40	P	L1
24.400	47.36	1.98	49.34	73.00	-23.66	P	L1
8.279	40.33	0.66	40.99	73.00	-32.01	P	L2
20.814	43.23	1.49	44.72	73.00	-28.28	P	L2
24.271	44.83	1.67	46.50	73.00	-26.50	P	L2

NOTE: 1. L1 = Line One (Live Line) / L2 = Line Two (Neutral Line)

2. The emission level was or more than 2dB below the Average limit, so no re-check anymore.



7 RADIATED EMISSION MEASUREMENT

7.1. LIMITS OF RADIATED EMISSION MEASUREMENT

FREQUENCY (MHz)	dBuV/m (At 10m)	
	Class A	Class B
30 ~ 230	40	30
230 ~ 1000	47	37

NOTE: (1) The lower limit shall apply at the transition frequencies.
 (2) Emission level (dBuV/m) = 20 log Emission level (uV/m).

7.2. TEST INSTRUMENTS

Open Area Test Site # I				
Name of Equipment	Manufacturer	Model	Serial Number	Calibration Due
SITE NSA	CCS	I Site	N/A	10/13/2007
MEASURE RECEIVER	SCHAFFNER	SCR3501	338	07/02/2007
SPECTRUM ANALYZER	ADVANTEST	R3132	120900008	No Calibration Required
ANTENNA	SCHAFFNER	CBL 6112B	2809	09/22/2007
AMPLIFIER	SCHAFFNER	CPA9231A	3626	10/10/2007
CABLE	BELDEN	9913	N-TYPE #I2	02/25/2008
ATTENUATOR	MCL	UNAT-6	AT06-3	10/10/2007
THERMO-HYGRO METER	TFA	N/A	NO.2	10/26/2007
Test S/W	LAB VIEW 7.1			

NOTE: 1. The calibration interval of the above test instruments is 12 months and the calibrations are traceable to NML/ROC and NIST/USA.
 2. N.C.R = No Calibration Request.



7.3. TEST PROCEDURES (please refer to measurement standard or CCS SOP PA -031)

Procedure of Preliminary Test

- The equipment was set up as per the test configuration to simulate typical usage per the user's manual. When the EUT is a tabletop system, a wooden turntable with a height of 0.8 meters is used which is placed on the ground plane. When the EUT is a floor standing equipment, it is placed on the ground plane which has a 3-12 mm non-conductive covering to insulate the EUT from the ground plane.
- Support equipment, if needed, was placed as per ANSI C63.4.
- All I/O cables were positioned to simulate typical usage as per ANSI C63.4.
- The EUT received AC power source from the outlet socket under the turntable. All support equipment power received from another socket under the turntable.
- The antenna was placed at 10 meter away from the EUT as stated in ANSI C63.4. The antenna connected to the Spectrum Analyzer via a cable and at times a pre-amplifier would be used.
- The Analyzer / Receiver quickly scanned from 30MHz to 8300MHz. The EUT test program was started. Emissions were scanned and measured rotating the EUT to 360 degrees and positioning the antenna 1 to 4 meters above the ground plane, in both the vertical and the horizontal polarization, to maximize the emission reading level.
- The test mode(s) described in Item 3.1 were scanned during the preliminary test:
- After the preliminary scan, we found the test mode described in Item 3.1 producing the highest emission level.
- The EUT and cable configuration, antenna position, polarization and turntable position of the above highest emission level were recorded for the final test.



Procedure of Final Test

- EUT and support equipment were set up on the turntable as per the configuration with highest emission level in the preliminary test.
- The Analyzer / Receiver scanned from 30MHz to 8300MHz. Emissions were scanned and measured rotating the EUT to 360 degrees, varying cable placement and positioning the antenna 1 to 4 meters above the ground plane, in both the vertical and the horizontal polarization, to maximize the emission reading level.
- Recorded at least the six highest emissions. Emission frequency, amplitude, antenna position, polarization and turntable position were recorded into a computer in which correction factors were used to calculate the emission level and compare reading to the applicable limit and only Q.P. reading is presented.
- The test data of the worst-case condition(s) was recorded.

7.4. TEST SETUP

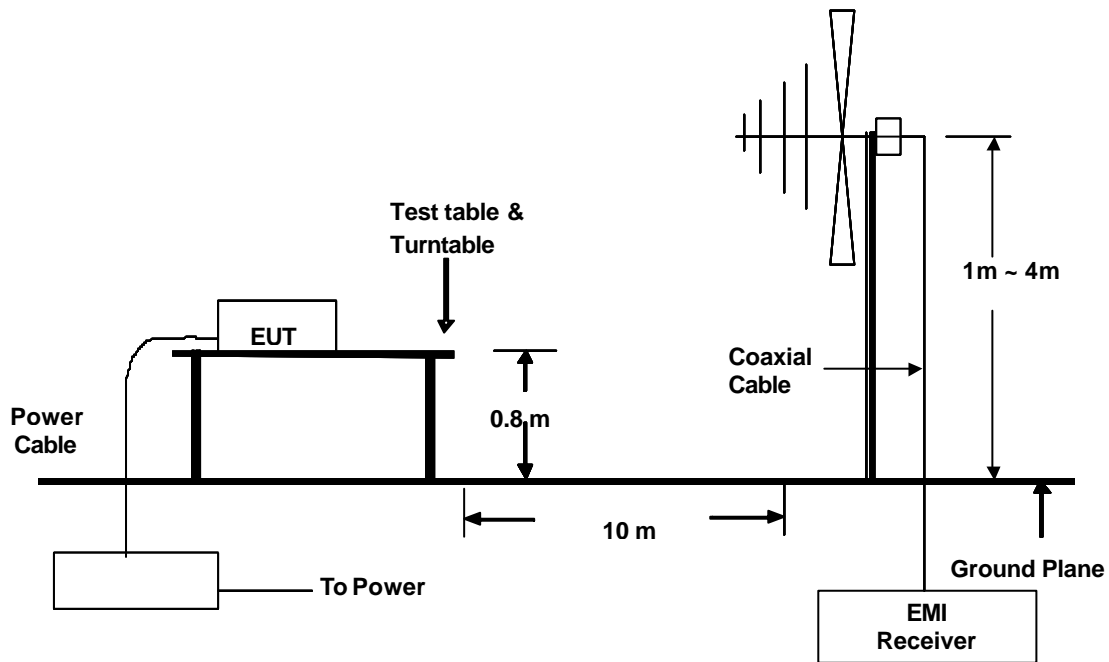

- For the actual test configuration, please refer to the related item – Photographs of the Test Configuration.

7.5. DATA SAMPLE

Freq. MHz	Read Level dBuV	Factor dB/m	Level dBuV/m	Limit dBuV/m	Over Limit dB	Reading Type (P/Q/A)	Pol. (H/V)
x.xx	14.0	12.2	26.2	40	-13.8	Q	H

- Freq. = Emission frequency in MHz
- Read Level = Uncorrected Analyzer/Receiver reading
- Factor = Antenna Factor + Cable Loss + Attenuator (3/6/10dB) – Amplifier Gain
- Level = Read Level + Factor
- Limit = Limit stated in standard
- Over Limit = Reading in reference to limit
- P = Peak Reading
- Q = Quasi-peak Reading
- A = Average Reading
- H = Antenna Polarization: Horizontal
- V = Antenna Polarization: Vertical

Calculation Formula

Over Limit (dB) = Level (dBuV/m) – Limit (dBuV/m)



7.6. TEST RESULTS

Model No.	APC-9172	Test Mode	Mode 1
Environmental Conditions	25deg.C, 70% RH, 1008 hPa	6dB Bandwidth	120 KHz
Antenna Pole	Vertical	Antenna Distance	10m
Detector Function	Quasi-peak.	Tested by	Alex Pan

(The chart below shows the highest readings taken from the final data.)

Six Highest Radiated Emission Readings							
Frequency Range Investigated				30 MHz to 1000 MHz at 10m			
Freq (MHz)	Read Level (dBuV)	Factor (dB/m)	Level (dBuV/m)	Limit Line (dBuV/m)	Over Limit (dB)	Reading Type (P/Q/A)	Pol. (H/V)
72.010	42.10	-14.02	28.08	40.00	-11.92	Q	V
166.673	44.80	-9.73	35.07	40.00	-4.93	Q	V
215.997	42.00	-9.53	32.47	40.00	-7.53	Q	V
239.999	44.80	-7.55	37.25	47.00	-9.75	Q	V
300.016	38.20	-4.45	33.75	47.00	-13.25	Q	V
600.170	33.50	3.67	37.17	47.00	-9.83	Q	V

- REMARKS:**
1. 30MHz to 1000MHz test is Applicable CISPR 22 / EN 55022 standard.
 2. The other emission levels were very low against the limit.
 3. P= Peak Reading; Q= Quasi-peak Reading A= Average Reading



Model No.	APC-9172	Test Mode	Mode 1
Environmental Conditions	25deg.C, 70% RH, 1008 hPa	6dB Bandwidth	120 KHz
Antenna Pole	Horizontal	Antenna Distance	10m
Detector Function	Quasi-peak.	Tested by	Alex Pan

(The chart below shows the highest readings taken from the final data.)

Six Highest Radiated Emission Readings							
Frequency Range Investigated				30 MHz to 1000 MHz at 10m			
Freq (MHz)	Read Level (dBuV)	Factor (dB/m)	Level (dBuV/m)	Limit Line (dBuV/m)	Over Limit (dB)	Reading Type (P/Q/A)	Pol. (H/V)
73.070	44.20	-13.98	30.22	40.00	-9.78	Q	H
166.685	44.20	-9.73	34.47	40.00	-5.53	Q	H
214.960	43.20	-9.61	33.59	40.00	-6.41	Q	H
239.992	40.50	-7.55	32.95	47.00	-14.05	Q	H
300.022	38.20	-4.45	33.75	47.00	-13.25	Q	H
600.020	32.50	3.67	36.17	47.00	-10.83	Q	H

- REMARKS:**
1. 30MHz to 1000MHz test is Applicable CISPR 22 / EN 55022 standard.
 2. The other emission levels were very low against the limit.
 3. P= Peak Reading; Q= Quasi-peak Reading A= Average Reading

8 PHOTOGRAPHS OF THE TEST CONFIGURATION CONDUCTED EMISSION TEST



RADIATED EMISSION TEST

