



FCC DoC TEST REPORT

for

Ethernet Operator Panel

MODEL: AOP-8070HT

Test Report Number:

70214203-F

Issued to:

AAEON Technology Inc.

**5F, No.135, Lane 235, Pao Chiao Rd., Hsin-Tien City,
Taipei, Taiwan, R.O.C.**

Issued by:

Compliance Certification Services Inc.

Sindian BU

**No.163-1, Jhongsheng Rd., Sindian City,
Taipei County 23151, Taiwan**

TEL: 886-2-22170894

FAX: 886-2-22171029

Issued Date: March 06, 2007



Note: This report shall not be reproduced except in full, without the written approval of Compliance Certification Services Inc. This document may be altered or revised by Compliance Certification Services Inc. personnel only, and shall be noted in the revision section of the document. The client should not use it to claim product endorsement by TAF, A2LA, NVLAP, NIST or any government agencies. The test results in the report only apply to the tested sample.



Revision History

| Rev. | Issue Date | Revisions | Effect Page | Revised By |
|------|------------|---------------|-------------|------------|
| 00 | | Initial Issue | ALL | |
| | | | | |
| | | | | |
| | | | | |



TABLE OF CONTENTS

1 TEST RESULT CERTIFICATION.....4

2 EUT DESCRIPTION.....5

3 TEST METHODOLOGY.....6

3.1. DECISION OF FINAL TEST MODE.....6

3.2. EUT SYSTEM OPERATION.....6

4 SETUP OF EQUIPMENT UNDER TEST.....7

4.1. DESCRIPTION OF SUPPORT UNITS.....7

4.2. CONFIGURATION OF SYSTEM UNDER TEST8

5 FACILITIES AND ACCREDITATIONS.....9

5.1. FACILITIES9

5.2. ACCREDITATIONS.....9

5.3. MEASUREMENT UNCERTAINTY.....9

6 CONDUCTED EMISSION MEASUREMENT10

6.1. LIMITS OF CONDUCTED EMISSION MEASUREMENT10

6.2. TEST INSTRUMENTS10

6.3. TEST PROCEDURES.....11

6.4. TEST SETUP.....12

6.5. DATA SAMPLE12

6.6. TEST RESULTS.....13

7 RADIATED EMISSION MEASUREMENT.....14

7.1. LIMITS OF RADIATED EMISSION MEASUREMENT14

7.2. TEST INSTRUMENTS14

7.3. TEST PROCEDURES.....15

7.4. TEST SETUP.....17

7.5. DATA SAMPLE17

7.6. TEST RESULTS.....18

8 PHOTOGRAPHS OF THE TEST CONFIGURATION.....20



1 TEST RESULT CERTIFICATION

Product: Ethernet Operator Panel

Brand: AAEON

Model: AOP-8070HT

Applicant: **AAEON Technology Inc.**
5F, No.135, Lane 235, Pao Chiao Rd., Hsin-Tien City,
Taipei, Taiwan, R.O.C.

Manufacturer: **AAEON Technology Inc.**
5F, No.135, Lane 235, Pao Chiao Rd., Hsin-Tien City,
Taipei, Taiwan, R.O.C.

Tested: February 13, 2007 ~ February 15, 2007

| EMISSION | | | |
|--|-----------------------|--------|--------------------|
| Standard | Item | Result | Remarks |
| FCC 47 CFR Part 15 Subpart B, ICES-003 Issue 4 ANSI C63.4-2003 | Conducted (Main Port) | PASS | Meet Class A limit |
| | Radiated | PASS | Meet Class A limit |

- Note:**
1. The test result judgment is decided by the limit of measurement standard.
 2. The information of measurement uncertainty is available upon the customer's request.

| Deviation from Applicable Standard |
|------------------------------------|
| None |



The above equipment has been tested by Compliance Certification Services Inc., and found compliance with the requirements set forth in the technical standards mentioned above. The results of testing in this report apply only to the product/system, which was tested. Other similar equipment will not necessarily produce the same results due to production tolerance and measurement uncertainties.

Approved by:

Reviewed by:



 David Wang
 Manager of Sindian BU

 Vince Chiang
 Assistant Manager of Sindian BU



2 EUT DESCRIPTION

| | |
|--------------------------------|--|
| Product | Ethernet Operator Panel |
| Brand Name | AAEON |
| Model | AOP-8070HT |
| Test Item | Engineering sample |
| Applicant | AAEON Technology Inc. |
| Housing material | Plastic w/ metal plate |
| EUT Type | <input checked="" type="checkbox"/> Engineering Sample . <input type="checkbox"/> Product Sample . <input type="checkbox"/> Mass Product Sample. |
| Serial Number | N/A |
| Received Date | February 14, 2007 |
| EUT Power Rating | (1) 12VDC, 1.66A (2) 24VDC, 1A |
| AC Adaptor Manufacturer | LIEN ELECTRONICS, INC. |
| AC Adaptor Model Number | (1) LE-0309BDSD20B (2) LE-0309BDSD24V |
| AC Adaptor Power Rating | (1) I/P: 100-240VAC, 50-60Hz, 1.4A; O/P: 12VDC, 1.66A (2) I/P: 100-240VAC, 50-60Hz, 1.4A; O/P: 24VDC, 1A |
| AC Power Cord Type | Unshielded, 1.8m (Detachable) to AC Adaptor |
| DC Power Cord Type | Unshielded, 1.3m (Non-detachable, with a core) to AC Adaptor |
| OSC/Clock Frequencies | 24.576MHz; 32.768KHz; 13MHz; 25MHz; 12MHz |

I/O PORT

| I/O PORT TYPES | Q' TY | TESTED WITH |
|----------------|-------|-------------|
| 1. SIO Port | 2 | 2 |
| 2. USB Port | 1 | 1 |
| 3. USB Port | 4 | 4 |
| 4. LAN Port | 1 | 1 |

Note: Client consigns only one model sample to test (Model Number: AOP-8070HT).



3 TEST METHODOLOGY

3.1. DECISION OF FINAL TEST MODE

The EUT was tested together with the above additional components, and a configuration, which produced the worst emission levels, was selected and recorded in this report.

The test configuration/ mode(s) is as the following:

Conduction(s):

| | |
|----|------------------------------|
| 1. | LE-0309BDSD20B / NORMAL MODE |
| 2. | LE-0309BDSD24V / NORMAL MODE |

Radiation:

| | |
|----|---------------------------------------|
| 1. | LE-0309BDSD20B / NORMAL MODE |
| 2. | LE-0309BDSD24V / NORMAL MODE |
| | LE-0309BDSD24V / NORMAL MODE / 1-5GHz |

Conduction: Mode 2

Radiation: Mode 2

3.2. EUT SYSTEM OPERATION

1. Windows CE boots system.
2. Run windows media player to play music.
3. Press the start menu, select executive and type ping 192.168.0.2-t (EUT), ping 192.168.0.1 -t (Server PC).

Note: Test program is self-repeating throughout the test.



4 SETUP OF EQUIPMENT UNDER TEST

4.1. DESCRIPTION OF SUPPORT UNITS

The EUT has been tested as an independent unit together with other necessary accessories or support units. The following support units or accessories were used to form a representative test configuration during the tests.

EUT Devices:

| No. | Equipment | Model No. | Trade Name |
|-----|------------------------|-------------------------|------------|
| 1 | CPU (Onboard / 520MHz) | XSCALE PXA270 | Intel |
| 2 | Memory (Onboard 128MB) | K4S51163PFPF75 (PC-133) | SAMSUNG |

Peripherals Devices:

| No. | Equipment | Model No. | Serial No. | FCC ID/ BSMI ID | Trade Name | Data Cable | Power Cord |
|-----|----------------|-------------|-------------|---------------------|--------------|-----------------|------------------|
| 1~2 | USB 2.0 HDD X2 | F12-U | N/A | BSMI ID: 4912A002 | TeraSys | Shielded, 1.8m | N/A |
| 3 | USB Mouse | M-BT85 | 831114-0000 | DOC BSMI: R41126 | LOGITECH | Shielded, 1.8m | N/A |
| 4 | USB Keyboard | Y-BL49 | STW42600036 | DOC BSMI: R41126 | LOGITECH | Shielded, 1.8m | N/A |
| 5 | Modem | 5JEG4033MKO | N/A | 5RJTAI-35500-M5-E | TOP-SOLUTION | Shielded, 1.8m | Unshielded, 1.8m |
| 6 | Server PC | DCNE | CV8DH1S | BSMI: R33002 | DELL | Unshielded, 20m | Unshielded, 1.8m |
| 7 | SIO Cable Load | N/A | N/A | N/A | N/A | Shielded, 1.8m | N/A |
| 8 | USB Cable Load | N/A | N/A | N/A | N/A | Shielded, 1.8m | N/A |

Note:

- 1) All the equipment/cables were placed in the worst-case configuration to maximize the emission during the test.
- 2) Grounding was established in accordance with the manufacturer's requirements and conditions for the intended use.

4.2. CONFIGURATION OF SYSTEM UNDER TEST

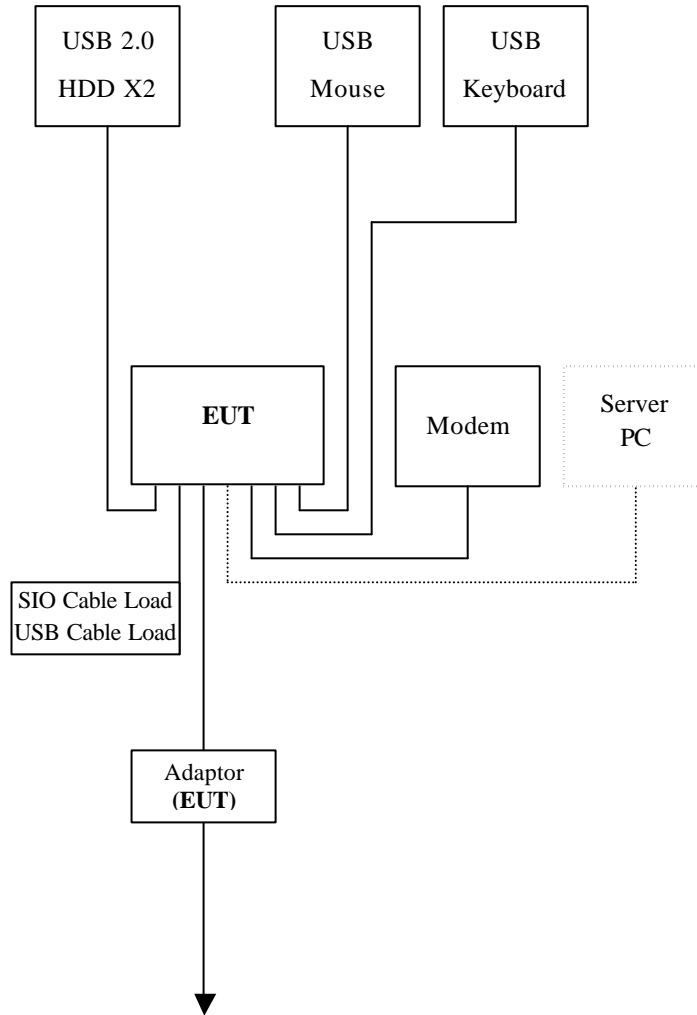



5 FACILITIES AND ACCREDITATIONS

5.1. FACILITIES

All measurement facilities used to collect the measurement data are located at CCS Taiwan Sindian BU at No.163-1, Jhongsheng Rd., Sindian City, Taipei County 23151, Taiwan.

The sites are constructed in conformance with the requirements of ANSI C63.4 and CISPR Publication 22. All receiving equipment conforms to CISPR Publication 16-1, "Radio Interference Measuring Apparatus and Measurement Methods."

5.2. ACCREDITATIONS

Our laboratories are accredited and approved by the following approval agencies according to ISO/IEC 17025.

| | |
|----------------|-----------------|
| USA | FCC, A2LA |
| Germany | TUV Rheinland |
| Japan | VCCI |
| Norway | NEMKO |
| Canada | INDUSTRY CANADA |
| Taiwan | TAF, BSMI |

Copies of granted accreditation certificates are available for downloading from our web site, <http://www.ccsemc.com.tw>

5.3. MEASUREMENT UNCERTAINTY

Where relevant, the following measurement uncertainty levels have been estimated for tests performed on the EUT as specified in CISPR 16-4-2:

| Measurement | Frequency | | Uncertainty |
|---------------------|------------|-----------------|-------------|
| Conducted emissions | 9kHz~30MHz | | ± 3.4510 |
| Radiated emissions | Horizontal | 30MHz ~ 200MHz | ± 4.3799 |
| | | 200MHz ~1000MHz | ± 4.5147 |
| | Vertical | 30MHz ~ 200MHz | ± 4.5015 |
| | | 200MHz ~1000MHz | ± 4.5073 |

This uncertainty represents an expanded uncertainty expressed at approximately the 95% confidence level using a coverage factor of k=2.



6 CONDUCTED EMISSION MEASUREMENT

6.1. LIMITS OF CONDUCTED EMISSION MEASUREMENT

| FREQUENCY (MHz) | Class A (dBuV) | | Class B (dBuV) | |
|-----------------|----------------|---------|----------------|---------|
| | Quasi-peak | Average | Quasi-peak | Average |
| 0.15 - 0.5 | 79 | 66 | 66 - 56 | 56 - 46 |
| 0.50 - 5.0 | 73 | 60 | 56 | 46 |
| 5.0 - 30.0 | 73 | 60 | 60 | 50 |

NOTE:

- (1) The lower limit shall apply at the transition frequencies.
- (2) The limit decreases in line with the logarithm of the frequency in the range of 0.15 to 0.50 MHz.
- (3) All emanations from a class A/B digital device or system, including any network of conductors and apparatus connected thereto, shall not exceed the level of field strengths specified above.

6.2. TEST INSTRUMENTS

| Conducted Emission Room # B | | | | |
|-----------------------------|--------------|---------|---------------|-----------------|
| Name of Equipment | Manufacturer | Model | Serial Number | Calibration Due |
| TEST RECEIVER | R&S | ESHS10 | 843743/015 | 03/28/2007 |
| LISN (EUT) | EMCO | 3825/2 | 9106-1810 | 01/03/2008 |
| LISN | EMCO | 3825/2 | 1382 | 01/03/2008 |
| BNC CABLE | MIYAZAKI | 5D-FB | BNC B1 | 07/13/2007 |
| Pulse Limiter | R&S | ESH3-Z2 | 100374 | 08/24/2007 |
| THERMO-HYGRO METER | TOP | HA-202 | 9303-3 | 02/04/2008 |
| Test S/W | EMI 32.exe | | | |

- NOTE:** 1. The calibration interval of the above test instruments is 12 months and the calibrations are traceable to NML/ROC and NIST/USA.
 2. N.C.R = No Calibration Request.



6.3. TEST PROCEDURES (please refer to measurement standard or CCS SOP PA -031)

Procedure of Preliminary Test

- The EUT and Support equipment, if needed, was set up as per the test configuration to simulate typical usage per the user's manual. When the EUT is a tabletop system, a wooden table with a height of 0.8 meters is used and is placed on the ground plane as per ANSI C63.4 (see Test Facility for the dimensions of the ground plane used). When the EUT is a floor standing equipment, it is placed on the ground plane, which has a 3-12 mm non-conductive covering to insulate the EUT from the ground plane.
- All I/O cables were positioned to simulate typical actual usage as per ANSI C63.4.
- The test equipment EUT installed received AC main power, through a Line Impedance Stabilization Network (LISN), which supplied power source and was grounded to the ground plane.
- All support equipment power received from a second LISN.
- The EUT test program was started. Emissions were measured on each current carrying line of the EUT using an EMI Test Receiver connected to the LISN powering the EUT.
- The Receiver scanned from 150kHz to 30MHz for emissions in each of the test modes.
- During the above scans, the emissions were maximized by cable manipulation.
- The test mode(s) described in Item 3.1 were scanned during the preliminary test.
- After the preliminary scan, we found the test mode described in Item 3.1 producing the highest emission level.
- The EUT configuration and cable configuration of the above highest emission levels were recorded for reference of the final test.

Procedure of Final Test

- EUT and support equipment were set up on the test bench as per the configuration with highest emission level in the preliminary test.
- A scan was taken on both power lines, Line 1 and Line 2, recording at least the six highest emissions. Emission frequency and amplitude were recorded into a computer in which correction factors were used to calculate the emission level and compare reading to the applicable limit.
- The test data of the worst-case condition(s) was recorded.

6.4. TEST SETUP

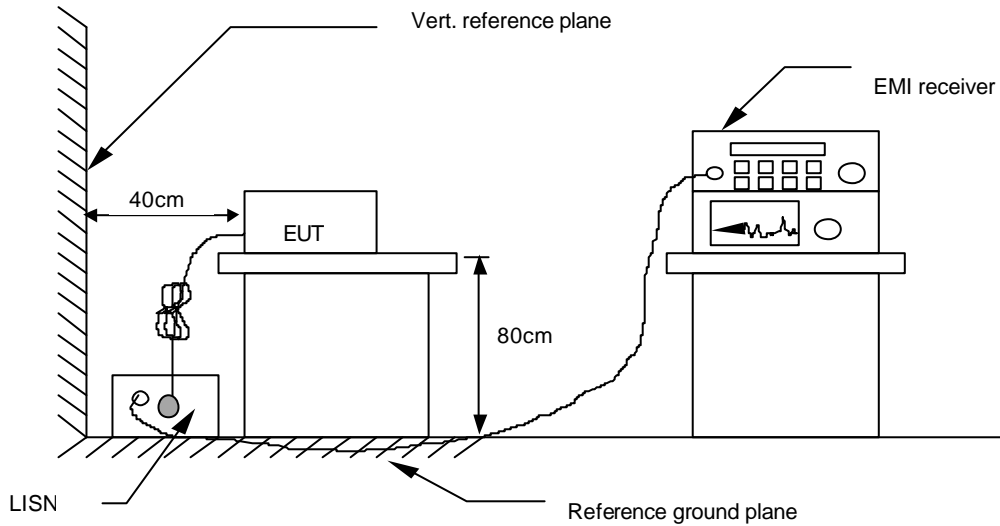

- For the actual test configuration, please refer to the related item – Photographs of the Test Configuration.

6.5. DATA SAMPLE

| Freq. MHz | Read Level dBuV | Factor dB | Level dBuV | Limit dBuV | Over Limit dB | Reading Type (P/Q/A) | Line (L1/L2) |
|-----------|-----------------|-----------|------------|------------|---------------|----------------------|--------------|
| x.xx | 42.95 | 0.55 | 43.50 | 73 | -29.50 | Q | L1 |

- Freq. = Emission frequency in MHz
- Read Level = Uncorrected Analyzer/Receiver reading
- Factor = Insertion loss of LISN + Cable Loss
- Level = Read Level + Factor
- Limit = Limit stated in standard
- Over Limit = Reading in reference to limit
- P = Peak Reading
- Q = Quasi-peak Reading
- A = Average Reading
- L1 = Hot side
- L2 = Neutral side

Calculation Formula

Over Limit (dB) = Level (dBuV) – Limit (dBuV)



6.6. TEST RESULTS

| | | | |
|---------------------------------|---------------------------|----------------------|--------|
| Model No. | AOP-8070HT | 6dB BANDWIDTH | 10 KHz |
| Environmental Conditions | 21deg.C, 57% RH, 1009 hPa | Test Mode | Mode 2 |
| Tested by | John Yen | | |

(The chart below shows the highest readings taken from the final data.)

| Six Highest Conducted Emission Readings | | | | | | | |
|---|-------------------|-------------|--------------|-------------------|-----------------|----------------------|--------------|
| Frequency Range Investigated | | | | 150 KHz to 30 MHz | | | |
| Freq (MHz) | Read Level (dBuV) | Factor (dB) | Level (dBuV) | Limit Line (dBuV) | Over Limit (dB) | Reading Type (P/Q/A) | Line (L1/L2) |
| 5.898 | 41.21 | 9.98 | 51.19 | 73.00 | -21.81 | P | L1 |
| 12.188 | 41.73 | 10.08 | 51.81 | 73.00 | -21.19 | P | L1 |
| 5.898 | 39.06 | 10.03 | 49.09 | 73.00 | -23.91 | P | L2 |
| 7.025 | 39.63 | 10.07 | 49.70 | 73.00 | -23.30 | P | L2 |
| 9.451 | 40.58 | 10.14 | 50.73 | 73.00 | -22.27 | P | L2 |
| 12.188 | 43.54 | 10.23 | 53.77 | 73.00 | -19.23 | P | L2 |

- NOTE: 1. L1 = Line One (Live Line) / L2 = Line Two (Neutral Line).
 2. The emission level was or more than 2dB below the Average limit, so no re-check anymore.



7 RADIATED EMISSION MEASUREMENT

7.1. LIMITS OF RADIATED EMISSION MEASUREMENT

| FREQUENCY (MHz) | dBuV/m (At 10m) | |
|-----------------|-----------------|---------|
| | Class A | Class B |
| 30 ~ 230 | 40 | 30 |
| 230 ~ 1000 | 47 | 37 |

NOTE: (1) The lower limit shall apply at the transition frequencies.

(2) Emission level (dBuV/m) = 20 log Emission level (uV/m).

7.2. TEST INSTRUMENTS

| Open Area Test Site # I | | | | |
|----------------------------|---------------|--------------|---------------|-------------------------|
| Name of Equipment | Manufacturer | Model | Serial Number | Calibration Due |
| SITE NSA | CCS | I Site | N/A | 10/13/2007 |
| MEASURE RECEIVER | SCHAFFNER | SCR3501 | 338 | 07/02/2007 |
| SPECTRUM ANALYZER | ADVANTEST | R3132 | 120900008 | No Calibration Required |
| ANTENNA | SCHAFFNER | CBL 6112B | 2809 | 09/22/2007 |
| AMPLIFIER | SCHAFFNER | CPA9231A | 3626 | 10/10/2007 |
| CABLE | BELDEN | 9913 | N-TYPE#I2 | 02/17/2007 |
| ATTENUATOR | MCL | UNAT-6 | AT06-3 | 10/10/2007 |
| THERMO-HYGRO METER | TFA | N/A | NO.2 | 10/26/2007 |
| Test S/W | LAB VIEW 7.1 | | | |
| Above 1GHz Used | | | | |
| EMC ANALYZER (100Hz-22GHz) | HP | 8566B | 2937A06102 | 06/29/2007 |
| ANTENNA (1-18GHz) | EMCO | 3115 | 00022256 | 01/16/2008 |
| AMPLIFIER (1-18GHz) | HP | 8449B | 3008A01266 | 02/13/2007 |
| CABLE (1-18GHz) | JYEBAO | LL142 | SMA#RS1 | 02/01/2008 |
| CABLE (1-18GHz) | HUBER +SUHNER | SUCOFLEX 104 | SMA#RS3 | 02/01/2008 |
| CABLE (1-18GHz) | JYEBAO | LL142 | SMA#C1 | 02/01/2008 |

NOTE: 1. The calibration interval of the above test instruments is 12 months and the calibrations are traceable to NML/ROC and NIST/USA.

2. N.C.R = No Calibration Request.



7.3. TEST PROCEDURES (please refer to measurement standard or CCS SOP PA -031)

Procedure of Preliminary Test

- The equipment was set up as per the test configuration to simulate typical usage per the user's manual. When the EUT is a tabletop system, a wooden turntable with a height of 0.8 meters is used which is placed on the ground plane. When the EUT is a floor standing equipment, it is placed on the ground plane which has a 3-12 mm non-conductive covering to insulate the EUT from the ground plane.
- Support equipment, if needed, was placed as per ANSI C63.4.
- All I/O cables were positioned to simulate typical usage as per ANSI C63.4.
- The EUT received AC power source from the outlet socket under the turntable. All support equipment power received from another socket under the turntable.
- The antenna was placed at 10 meter away from the EUT as stated in ANSI C63.4. The antenna connected to the Spectrum Analyzer via a cable and at times a pre-amplifier would be used.
- The Analyzer / Receiver quickly scanned from 30MHz to 5000MHz. The EUT test program was started. Emissions were scanned and measured rotating the EUT to 360 degrees and positioning the antenna 1 to 4 meters above the ground plane, in both the vertical and the horizontal polarization, to maximize the emission reading level.
- The test mode(s) described in Item 3.1 were scanned during the preliminary test:
- After the preliminary scan, we found the test mode described in Item 3.1 producing the highest emission level.
- The EUT and cable configuration, antenna position, polarization and turntable position of the above highest emission level were recorded for the final test.



Procedure of Final Test

- EUT and support equipment were set up on the turntable as per the configuration with highest emission level in the preliminary test.
- The Analyzer / Receiver scanned from 30MHz to 5000MHz. Emissions were scanned and measured rotating the EUT to 360 degrees, varying cable placement and positioning the antenna 1 to 4 meters above the ground plane, in both the vertical and the horizontal polarization, to maximize the emission reading level.
- Recorded at least the six highest emissions. Emission frequency, amplitude, antenna position, polarization and turntable position were recorded into a computer in which correction factors were used to calculate the emission level and compare reading to the applicable limit and only Q.P. reading is presented.
- The test data of the worst-case condition(s) was recorded.

7.4. TEST SETUP

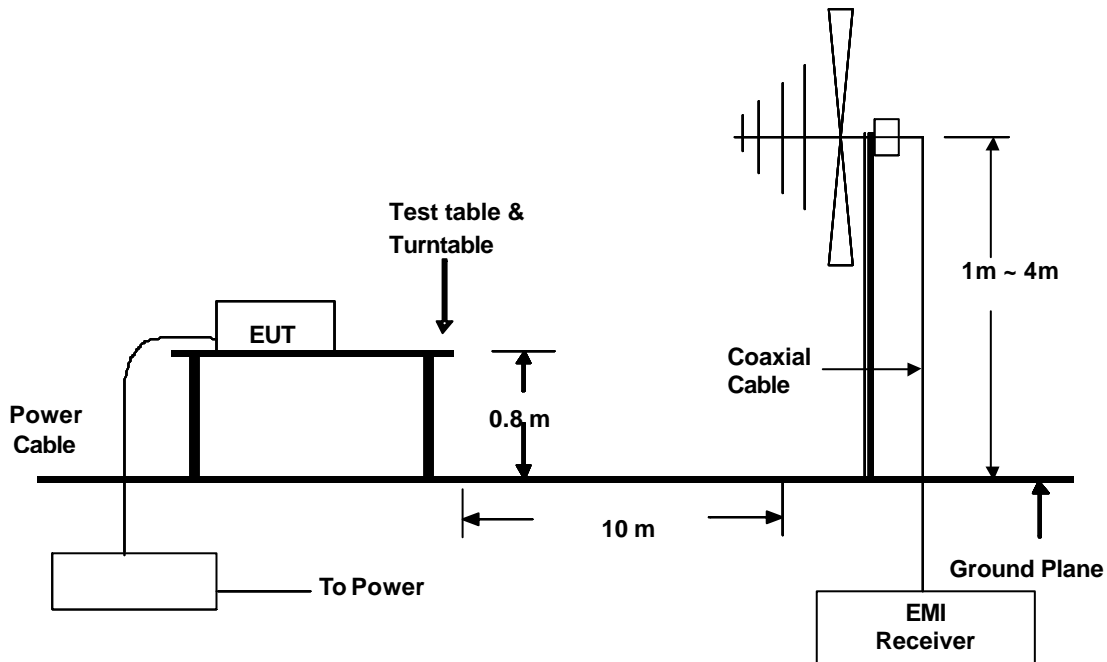

- For the actual test configuration, please refer to the related item – Photographs of the Test Configuration.

7.5. DATA SAMPLE

| Freq. MHz | Read Level dBuV | Factor dB/m | Level dBuV/m | Limit dBuV/m | Over Limit dB | Reading Type (P/Q/A) | Pol. (H/V) |
|-----------|-----------------|-------------|--------------|--------------|---------------|----------------------|------------|
| x.xx | 14.0 | 12.2 | 26.2 | 40 | -13.8 | Q | H |

- Freq. = Emission frequency in MHz
- Read Level = Uncorrected Analyzer/Receiver reading
- Factor = Antenna Factor + Cable Loss + Attenuator (3/6/10dB) – Amplifier Gain
- Level = Read Level + Factor
- Limit = Limit stated in standard
- Over Limit = Reading in reference to limit
- P = Peak Reading
- Q = Quasi-peak Reading
- A = Average Reading
- H = Antenna Polarization: Horizontal
- V = Antenna Polarization: Vertical

Calculation Formula

Over Limit (dB) = Level (dBuV/m) – Limit (dBuV/m)



7.6. TEST RESULTS

| | | | |
|---------------------------------|---------------------------|-------------------------|----------|
| Model No. | AOP-8070HT | Test Mode | Mode 2 |
| Environmental Conditions | 26deg.C, 60% RH, 1005 hPa | 6dB BANDWIDTH | 120 KHz |
| Antenna Pole | Vertical | Antenna Distance | 10m |
| Detector Function | Quasi-peak. | Tested by | John Yen |

(The chart below shows the highest readings taken from the final data.)

| Six Highest Radiated Emission Readings | | | | | | | |
|--|-------------------|---------------|----------------|---------------------------|-----------------|----------------------|------------|
| Frequency Range Investigated | | | | 30 MHz to 1000 MHz at 10m | | | |
| Freq (MHz) | Read Level (dBuV) | Factor (dB/m) | Level (dBuV/m) | Limit Line (dBuV/m) | Over Limit (dB) | Reading Type (P/Q/A) | Pol. (H/V) |
| 45.437 | 47.90 | -12.09 | 35.81 | 40.00 | -4.19 | Q | V |
| 54.106 | 48.38 | -16.14 | 32.24 | 40.00 | -7.76 | Q | V |
| 84.760 | 45.24 | -13.03 | 32.21 | 40.00 | -7.79 | Q | V |
| 125.000 | 45.06 | -8.73 | 36.33 | 40.00 | -3.67 | Q | V |
| 250.009 | 50.27 | -7.35 | 42.92 | 47.00 | -4.08 | Q | V |
| 318.440 | 43.00 | -5.02 | 37.98 | 47.00 | -9.02 | Q | V |

- REMARKS:**
1. 30MHz to 1000MHz test is Applicable CISPR 22 / EN 55022 standard.
 2. The other emission levels were very low against the limit.
 3. P= Peak Reading; Q= Quasi-peak Reading A= Average Reading.



| | | | |
|---------------------------------|---------------------------|-------------------------|----------|
| ModelNo. | AOP-8070HT | Test Mode | Mode 2 |
| Environmental Conditions | 26deg.C, 60% RH, 1005 hPa | 6dB BANDWIDTH | 120 KHz |
| Antenna Pole | Horizontal | Antenna Distance | 10m |
| Detector Function | Quasi-peak. | Tested by | John Yen |

(The chart below shows the highest readings taken from the final data.)

| Six Highest Radiated Emission Readings | | | | | | | |
|--|-------------------|---------------|----------------|---------------------------|-----------------|----------------------|------------|
| Frequency Range Investigated | | | | 30 MHz to 1000 MHz at 10m | | | |
| Freq (MHz) | Read Level (dBuV) | Factor (dB/m) | Level (dBuV/m) | Limit Line (dBuV/m) | Over Limit (dB) | Reading Type (P/Q/A) | Pol. (H/V) |
| 45.183 | 48.67 | -11.93 | 36.74 | 40.00 | -3.26 | Q | H |
| 125.022 | 44.28 | -8.73 | 35.55 | 40.00 | -4.45 | Q | H |
| 250.018 | 50.30 | -7.35 | 42.95 | 47.00 | -4.05 | Q | H |
| 315.130 | 39.27 | -5.06 | 34.21 | 47.00 | -12.79 | Q | H |
| 500.048 | 37.69 | 0.05 | 37.74 | 47.00 | -9.26 | Q | H |
| 715.005 | 35.15 | 3.44 | 38.59 | 47.00 | -8.41 | Q | H |

- REMARKS:**
1. 30MHz to 1000MHz test is Applicable CISPR 22 / EN 55022 standard.
 2. The other emission levels were very low against the limit.
 3. P= Peak Reading; Q= Quasi-peak Reading A= Average Reading.

8 PHOTOGRAPHS OF THE TEST CONFIGURATION CONDUCTED EMISSION TEST



RADIATED EMISSION TEST

