



FCC DoC TEST REPORT

for

Operator Panel PC

MODEL: xxxxxAOP-8060XT-xx-xxxx

Test Report Number:

70511207-F

Issued to:

AAEON Technology Inc.

**5F, No.135, Lane 235, Pao Chiao Rd., Hsin-Tien City,
Taipei, Taiwan, R.O.C.**

Issued by:

Compliance Certification Services Inc.

Sindian BU

**No.163-1, Jhongsheng Rd., Sindian City,
Taipei County 23151, Taiwan**

TEL: 886-2-22170894

FAX: 886-2-22171029

Issued Date: May 28, 2007



Note: This report shall not be reproduced except in full, without the written approval of Compliance Certification Services Inc. This document may be altered or revised by Compliance Certification Services Inc. personnel only, and shall be noted in the revision section of the document. The client should not use it to claim product endorsement by TAF, A2LA, NVLAP, NIST or any government agencies. The test results in the report only apply to the tested sample.



Revision History

Rev.	Issue Date	Revisions	Effect Page	Revised By
00		Initial Issue	ALL	



TABLE OF CONTENTS

1 TEST RESULT CERTIFICATION.....4

2 EUT DESCRIPTION.....5

3 TEST METHODOLOGY.....6

3.1. DECISION OF FINAL TEST MODE.....6

3.2. EUT SYSTEM OPERATION.....6

4 SETUP OF EQUIPMENT UNDER TEST.....7

4.1. DESCRIPTION OF SUPPORT UNITS.....7

4.2. CONFIGURATION OF SYSTEM UNDER TEST8

5 FACILITIES AND ACCREDITATIONS.....9

5.1. FACILITIES9

5.2. ACCREDITATIONS.....9

5.3. MEASUREMENT UNCERTAINTY.....9

6 CONDUCTED EMISSION MEASUREMENT10

6.1. LIMITS OF CONDUCTED EMISSION MEASUREMENT10

6.2. TEST INSTRUMENTS10

6.3. TEST PROCEDURES.....11

6.4. TEST SETUP.....12

6.5. DATA SAMPLE12

6.6. TEST RESULTS.....13

7 RADIATED EMISSION MEASUREMENT.....14

7.1. LIMITS OF RADIATED EMISSION MEASUREMENT14

7.2. TEST INSTRUMENTS14

7.3. TEST PROCEDURES.....15

7.4. TEST SETUP.....17

7.5. DATA SAMPLE17

7.6. TEST RESULTS.....18

8 PHOTOGRAPHS OF THE TEST CONFIGURATION.....20



1 TEST RESULT CERTIFICATION

Product: Operator Panel PC
Brand: AAEON
Model: xxxxxAOP-8060XT-xx-xxxx(Where y is T or blank and x is 0-9,A-Z ,- or blank)
Applicant: AAEON Technology Inc.
5F, No.135, Lane 235, Pao Chiao Rd., Hsin-Tien City, Taipei, Taiwan, R.O.C.
Manufacturer: AAEON Technology Inc.
5F, No.135, Lane 235, Pao Chiao Rd., Hsin-Tien City, Taipei, Taiwan, R.O.C.
Tested: May 11, 2007

Table with 4 columns: Standard, Item, Result, Remarks. Rows include FCC 47 CFR Part 15 Subpart B, ICES-003 Issue 4, ANSI C63.4-2003 with items Conducted (Main Port) and Radiated, both resulting in PASS.

Note: 1. The test result judgment is decided by the limit of measurement standard.
2. The information of measurement uncertainty is available upon the customer's request.

Table with 1 column: Deviation from Applicable Standard. Value: None

The above equipment has been tested by Compliance Certification Services Inc., and found compliance with the requirements set forth in the technical standards mentioned above. The results of testing in this report apply only to the product/system, which was tested. Other similar equipment will not necessarily produce the same results due to production tolerance and measurement uncertainties.

Approved by:

Reviewed by:

Signature of David Wang
David Wang
Manager of Sindian BU

Signature of Vince Chiang
Vince Chiang
Assistant Manager of Sindian BU



2 EUT DESCRIPTION

Product	Operator Panel PC
Brand Name	AAEON
Model	xxxxxAOP-8060XT-xx-xxxx(Where y is T or blank and x is 0-9,A-Z,- or blank)
Test Item	Engineering sample
Applicant	AAEON Technology Inc.
Housing material	Plastic w/ metal plate
EUT Type	<input checked="" type="checkbox"/> Engineering Sample . <input type="checkbox"/> Product Sample . <input type="checkbox"/> Mass Product Sample.
Serial Number	N/A
Received Date	May 11, 2007
AC Power During Test	120VAC / 60 Hz
EUT Power Rating	5VDC from AC Adaptor
ACA daptor Manufacturer	SINPRO
ACA daptor Model Number	SPU50-1
ACA daptor Power Rating	I/P: 100-240VAC, 47-63Hz; O/P: 5-6VDC
DC Power Cable Type	Unshielded, 1.2m (Non-detachable, with a core) to AC A daptor
OSC/Clock Frequencies	14.31818MHz; 25MHz; 32.768KHz; 24.576MHz

I/O PORT

I/O PORT TYPES	Q' TY	TESTED WITH
1. SIO Port	1	1
2. PS/2 one to two adaptor	1	1
3. VIDEO-OUT Port (VGA)	1	1
4. AUDIO OUT Port	1	1
5. LAN Port	1	1
6. USB Port	2	2
7. CF Slot	1	1

Note: Client consigns only one model sample to test (Model Number: AOP-8060XT).



3 TEST METHODOLOGY

3.1. DECISION OF FINAL TEST MODE

The EUT was tested together with the above additional components, and a configuration, which produced the worst emission levels, was selected and recorded in this report.

The test configuration/ mode is as the following:

Conduction:

1.	NORMAL MODE
----	-------------

Radiation:

1.	NORMAL MODE
	NORMAL MODE / 1-6.5GHz

Conduction: Mode 1

Radiation: Mode 1

3.2. EUT SYSTEM OPERATION

1. Windows XP boots system.
2. Run Emctest.exe to activate all peripherals and display “H” pattern on monitor screen.
3. Run Winemc.exe and choose “F:/ & G:/” to test EUT.
4. Press the start menu, select executive and type ping 192.168.0.2-t (EUT), ping 192.168.0.1 -t (Server Notebook).

Note: Test program is self-repeating throughout the test.



4 SETUP OF EQUIPMENT UNDER TEST

4.1. DESCRIPTION OF SUPPORT UNITS

The EUT has been tested as an independent unit together with other necessary accessories or support units. The following support units or accessories were used to form a representative test configuration during the tests.

EUT Devices:

No.	Equipment	Model No.	Trade Name
1	Memory	D5116AFTA-6B-E	ELPIDA, 512MB, DDR
2	CPU	Celeron M, 1.30GHz	Genuine Intel(R)
3	CFD (2GB)	N/A	PQI
4	Power Supply	SPU50-1	SINPRO

Peripherals Devices:

No.	Equipment	Model No.	Serial No.	FCC ID/ BSMI ID	Trade Name	Data Cable	Power Cord
1	Earphone	MSB301	N/A	N/A	e-Sense	Unshielded, 1.8m	N/A
2	PS/2 Mouse	M071KC	443029438	DoC BSMI: R41108	DELL	Shielded, 1.8m	N/A
3	PS/2 Keyboard	SK-8110	N/A	DoC BSMI: T3A002	DELL	Shielded, 1.8m	N/A
4-5	USB 2.0 HDD X2	F12-U	N/A	BSMI ID: 4912A002	TeraSys	Shielded, 1.8m	N/A
6	Modem	5JEG4033MKO	N/A	5RJTAI-35500-M5-E	TOP-SOLUTION	Shielded, 1.5m	Unshielded, 1.8m
7	Monitor	710V	GS17H9NXA05857N	DOC BSMI: R33475	SAMSUNG	Shielded, 1.8m with two cores	Unshielded, 1.8m
8	Server Notebook	PP05L	2464936188	DoC BSMI: R33002	DELL	Unshielded, 20m	Unshielded, 1.8m

Note:

- 1) All the equipment/cables were placed in the worst-case configuration to maximize the emission during the test.
- 2) Grounding was established in accordance with the manufacturer's requirements and conditions for the intended use.

4.2. CONFIGURATION OF SYSTEM UNDER TEST

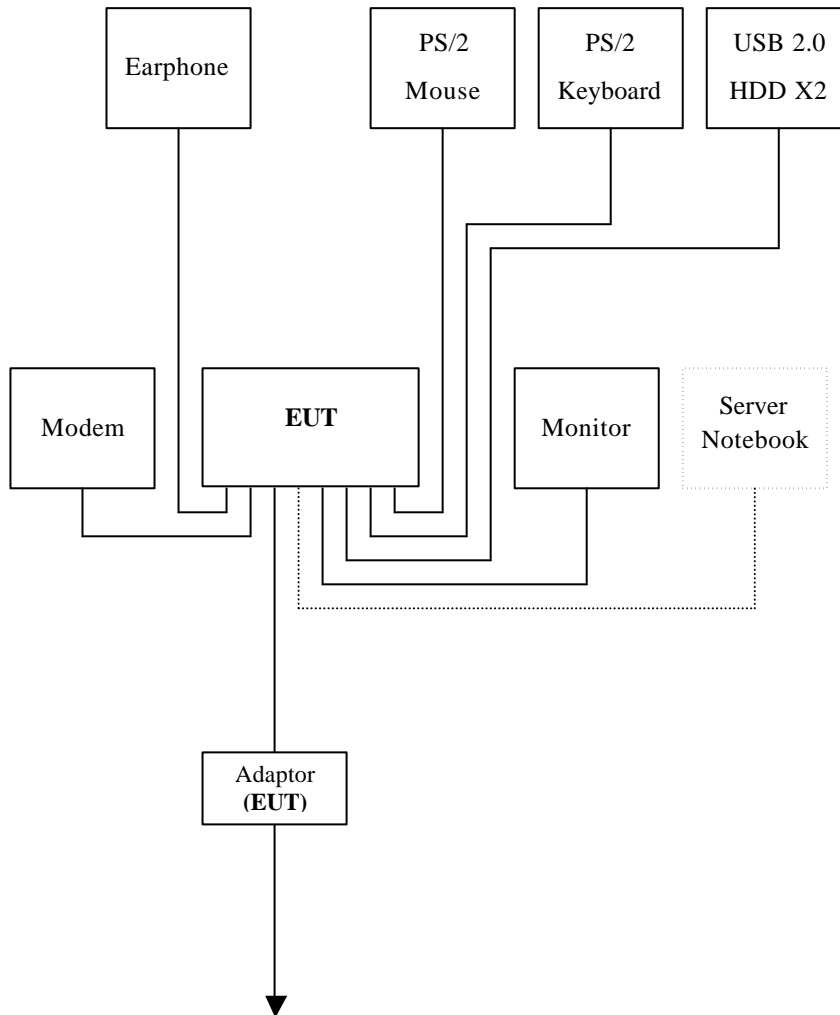



5 FACILITIES AND ACCREDITATIONS

5.1. FACILITIES

All measurement facilities used to collect the measurement data are located at CCS Taiwan Sindian BU at No.163-1, Jhongsheng Rd., Sindian City, Taipei County 23151, Taiwan.

The sites are constructed in conformance with the requirements of ANSI C63.4 and CISPR Publication 22. All receiving equipment conforms to CISPR Publication 16-1, "Radio Interference Measuring Apparatus and Measurement Methods."

5.2. ACCREDITATIONS

Our laboratories are accredited and approved by the following approval agencies according to ISO/IEC 17025.

USA	FCC, A2LA
Germany	TUV Rheinland
Japan	VCCI
Norway	NEMKO
Canada	INDUSTRY CANADA
Taiwan	TAF, BSMI

Copies of granted accreditation certificates are available for downloading from our web site, <http://www.ccsemc.com.tw>

5.3. MEASUREMENT UNCERTAINTY

Where relevant, the following measurement uncertainty levels have been estimated for tests performed on the EUT as specified in CISPR 16-4-2:

Measurement	Frequency		Uncertainty
Conducted emissions	9kHz~30MHz		± 3.4508
Radiated emissions	Horizontal	30MHz ~ 200MHz	± 4.3801
		200MHz ~1000MHz	± 4.5154
	Vertical	30MHz ~ 200MHz	± 4.5017
		200MHz ~1000MHz	± 4.5080

This uncertainty represents an expanded uncertainty expressed at approximately the 95% confidence level using a coverage factor of k=2.



6 CONDUCTED EMISSION MEASUREMENT

6.1. LIMITS OF CONDUCTED EMISSION MEASUREMENT

FREQUENCY (MHz)	Class A (dBuV)		Class B (dBuV)	
	Quasi-peak	Average	Quasi-peak	Average
0.15 - 0.5	79	66	66 - 56	56 - 46
0.50 - 5.0	73	60	56	46
5.0 - 30.0	73	60	60	50

NOTE:

- (1) The lower limit shall apply at the transition frequencies.
- (2) The limit decreases in line with the logarithm of the frequency in the range of 0.15 to 0.50 MHz.
- (3) All emanations from a class A/B digital device or system, including any network of conductors and apparatus connected thereto, shall not exceed the level of field strengths specified above.

6.2. TEST INSTRUMENTS

Conducted Emission Room # A				
Name of Equipment	Manufacturer	Model	Serial Number	Calibration Due
TEST RECEIVER	R&S	ESHS20	840455/006	02/12/2008
LISN (EUT)	SCHWARZBECK	NSLK 8127	8127382	12/06/2007
LISN	SOLAR	8012-50-R-24-BNC	8305114	12/26/2007
BNC CABLE	Huber+Suhner	RG-223/U	BNCA2	05/13/2008
THERMO-HYGRO METER	TOP	HA-202	9303-1	02/04/2008
Test S/W	EMI 32.exe			

- NOTE:** 1. The calibration interval of the above test instruments is 12 months and the calibrations are traceable to NML/ROC and NIST/USA.
 2. N.C.R = No Calibration Request.



6.3. TEST PROCEDURES (please refer to measurement standard or CCS SOP PA -031)

Procedure of Preliminary Test

- The EUT and Support equipment, if needed, was set up as per the test configuration to simulate typical usage per the user's manual. When the EUT is a tabletop system, a wooden table with a height of 0.8 meters is used and is placed on the ground plane as per ANSI C63.4 (see Test Facility for the dimensions of the ground plane used). When the EUT is a floor standing equipment, it is placed on the ground plane, which has a 3-12 mm non-conductive covering to insulate the EUT from the ground plane.
- All I/O cables were positioned to simulate typical actual usage as per ANSI C63.4.
- The test equipment EUT installed received AC main power, through a Line Impedance Stabilization Network (LISN), which supplied power source and was grounded to the ground plane.
- All support equipment power received from a second LISN.
- The EUT test program was started. Emissions were measured on each current carrying line of the EUT using an EMI Test Receiver connected to the LISN powering the EUT.
- The Receiver scanned from 150kHz to 30MHz for emissions in each of the test modes.
- During the above scans, the emissions were maximized by cable manipulation.
- The test mode(s) described in Item 3.1 were scanned during the preliminary test.
- After the preliminary scan, we found the test mode described in Item 3.1 producing the highest emission level.
- The EUT configuration and cable configuration of the above highest emission levels were recorded for reference of the final test.

Procedure of Final Test

- EUT and support equipment were set up on the test bench as per the configuration with highest emission level in the preliminary test.
- A scan was taken on both power lines, Line 1 and Line 2, recording at least the six highest emissions. Emission frequency and amplitude were recorded into a computer in which correction factors were used to calculate the emission level and compare reading to the applicable limit.
- The test data of the worst-case condition(s) was recorded.

6.4. TEST SETUP

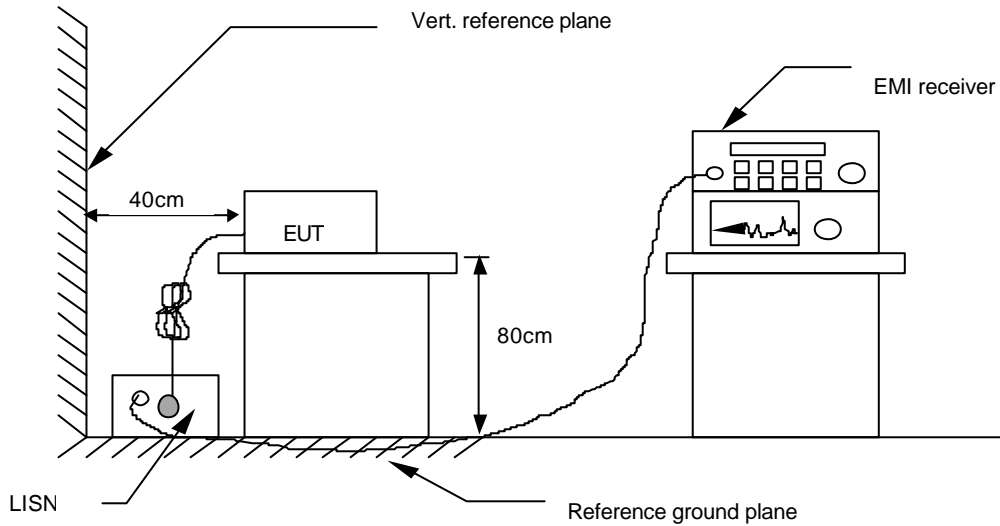

- For the actual test configuration, please refer to the related item – Photographs of the Test Configuration.

6.5. DATA SAMPLE

Freq. MHz	Read Level dBuV	Factor dB	Level dBuV	Limit dBuV	Over Limit dB	Reading Type (P/Q/A)	Line (L1/L2)
x.xx	42.95	0.55	43.50	73	-29.50	Q	L1

- Freq. = Emission frequency in MHz
- Read Level = Uncorrected Analyzer/Receiver reading
- Factor = Insertion loss of LISN + Cable Loss
- Level = Read Level + Factor
- Limit = Limit stated in standard
- Over Limit = Reading in reference to limit
- P = Peak Reading
- Q = Quasi-peak Reading
- A = Average Reading
- L1 = Hot side
- L2 = Neutral side

Calculation Formula

Over Limit (dB) = Level (dBuV) – Limit (dBuV)



6.6. TEST RESULTS

Model No.	AOP-8060XT	6dB BANDWIDTH	10 KHz
Environmental Conditions	26deg.C, 53% RH, 1012 hPa	Test Mode	Mode 1
Tested by	Jason Chia		

(The chart below shows the highest readings taken from the final data.)

Six Highest Conducted Emission Readings							
Frequency Range Investigated				150 KHz to 30 MHz			
Freq (MHz)	Read Level (dBuV)	Factor (dB)	Level (dBuV)	Limit Line (dBuV)	Over Limit (dB)	Reading Type (P/Q/A)	Line (L1/L2)
0.217	48.03	0.44	48.47	79.00	-30.53	P	L1
0.329	52.69	0.58	53.27	79.00	-25.73	P	L1
0.217	49.35	0.15	49.50	79.00	-29.50	P	L2
0.334	46.17	0.15	46.32	79.00	-32.68	P	L2
0.444	47.39	0.17	47.56	79.00	-31.44	P	L2
0.994	40.91	0.20	41.11	73.00	-31.89	P	L2

- NOTE: 1. L1 = Line One (Live Line) / L2 = Line Two (Neutral Line).
 2. The emission level was or more than 2dB below the Average limit, so no re-check anymore.



7 RADIATED EMISSION MEASUREMENT

7.1. LIMITS OF RADIATED EMISSION MEASUREMENT

FREQUENCY (MHz)	dBuV/m (At 10m)	
	Class A	Class B
30 ~ 230	40	30
230 ~ 1000	47	37

NOTE: (1) The lower limit shall apply at the transition frequencies.
 (2) Emission level (dBuV/m) = 20 log Emission level (uV/m).

7.2. TEST INSTRUMENTS

Open Area Test Site # K				
Name of Equipment	Manufacturer	Model	Serial Number	Calibration Due
SITE NSA	CCS	K Site	N/A	09/30/2007
MEASURE RECEIVER	SCHAFFNER	SCR3501	412	05/18/2007
SPECTRUM ANALYZER	ADVANTEST	R3132	120900029	No Calibration Required
ANTENNA	SCHAFFNER	CBL 6112B	2846	05/26/2007
PRE-AMPLIFIER	SCHAFFNER	CPA9231A	3639	10/10/2007
CABLE	SUHNER	RG 214	N-TYPE #K2	02/25/2008
THERMO-HYGRO METER	TFA	N/A	NO.4	01/31/2008
Test S/W	LAB VIEW 5.1			
Above 1GHz Used				
EMC ANALYZER (100Hz-22GHz)	HP	8566B	2937A06102	07/04/2007
ANTENNA (1-18GHz)	EMCO	3115	00022256	01/16/2008
AMPLIFIER (1-18GHz)	HP	8449B	3008A01266	02/11/2008
CABLE (1-18GHz)	JYEBAO	LL142	SMA#RS1	02/01/2008
CABLE (1-18GHz)	HUBER +SUHNER	SUCOFLEX 104	SMA#RS3	02/01/2008
CABLE (1-18GHz)	JYEBAO	LL142	SMA#C1	02/01/2008

NOTE: 1. The calibration interval of the above test instruments is 12 months and the calibrations are traceable to NML/ROC and NIST/USA.
 2. N.C.R = No Calibration Request.



7.3. TEST PROCEDURES (please refer to measurement standard or CCS SOP PA -031)

Procedure of Preliminary Test

- The equipment was set up as per the test configuration to simulate typical usage per the user's manual. When the EUT is a tabletop system, a wooden turntable with a height of 0.8 meters is used which is placed on the ground plane. When the EUT is a floor standing equipment, it is placed on the ground plane which has a 3-12 mm non-conductive covering to insulate the EUT from the ground plane.
- Support equipment, if needed, was placed as per ANSI C63.4.
- All I/O cables were positioned to simulate typical usage as per ANSI C63.4.
- The EUT received AC power source from the outlet socket under the turntable. All support equipment power received from another socket under the turntable.
- The antenna was placed at 10 meter away from the EUT as stated in ANSI C63.4. The antenna connected to the Spectrum Analyzer via a cable and at times a pre-amplifier would be used.
- The Analyzer / Receiver quickly scanned from 30MHz to 6500MHz. The EUT test program was started. Emissions were scanned and measured rotating the EUT to 360 degrees and positioning the antenna 1 to 4 meters above the ground plane, in both the vertical and the horizontal polarization, to maximize the emission reading level.
- The test mode(s) described in Item 3.1 were scanned during the preliminary test:
- After the preliminary scan, we found the test mode described in Item 3.1 producing the highest emission level.
- The EUT and cable configuration, antenna position, polarization and turntable position of the above highest emission level were recorded for the final test.



Procedure of Final Test

- EUT and support equipment were set up on the turntable as per the configuration with highest emission level in the preliminary test.
- The Analyzer / Receiver scanned from 30MHz to 6500MHz. Emissions were scanned and measured rotating the EUT to 360 degrees, varying cable placement and positioning the antenna 1 to 4 meters above the ground plane, in both the vertical and the horizontal polarization, to maximize the emission reading level.
- Recorded at least the six highest emissions. Emission frequency, amplitude, antenna position, polarization and turntable position were recorded into a computer in which correction factors were used to calculate the emission level and compare reading to the applicable limit and only Q.P. reading is presented.
- The test data of the worst-case condition(s) was recorded.

7.4. TEST SETUP

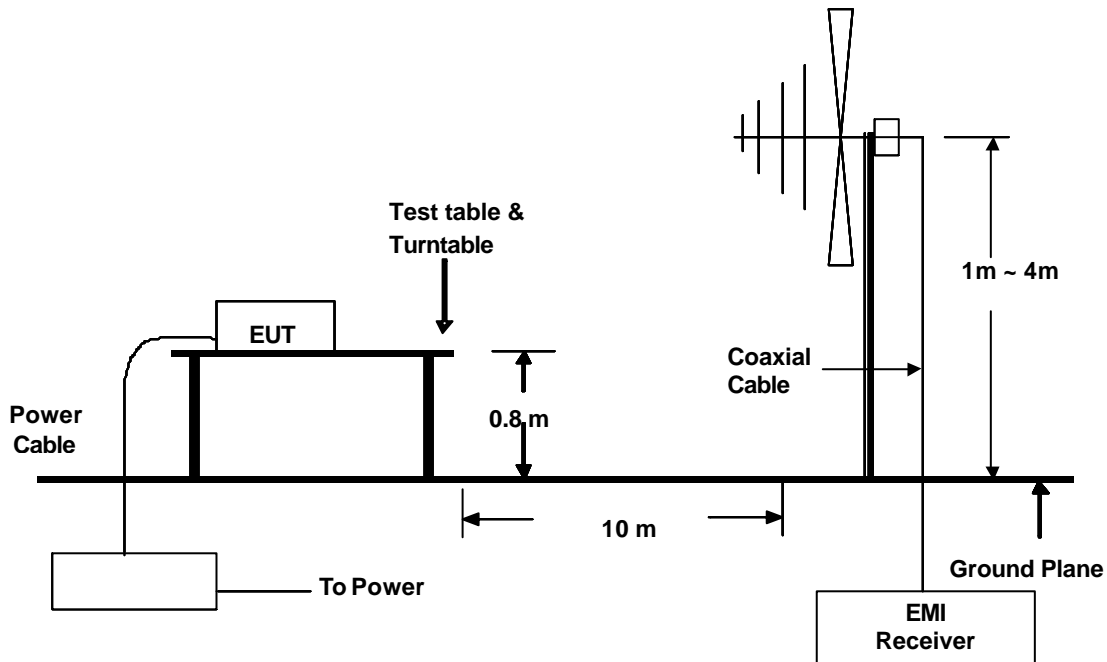

- For the actual test configuration, please refer to the related item – Photographs of the Test Configuration.

7.5. DATA SAMPLE

Freq. MHz	Amptd dBuV/m	Margin dB	Limit dBuV/m	Reading dBuV	Factor dB/m	Reading Type (P/Q/A)	Pol. (H/V)
x.xx	26.2	-13.8	40	14	12.2	Q	H

- Freq. = Emission frequency in MHz
- Reading = Uncorrected Analyzer/Receiver reading
- Factor = Antenna Factor + Cable Loss + Attenuator (3/6/10dB) – Amplifier Gain
- Amptd = Uncorrected Analyzer/Receiver reading + Factor
- Limit = Limit stated in standard
- Margin = Reading in reference to limit
- P = Peak Reading
- Q = Quasi-peak Reading
- A = Average Reading
- H = Antenna Polarization: Horizontal
- V = Antenna Polarization: Vertical

Calculation Formula

Margin (dB) = Amptd (dBuV/m) – Limit (dBuV/m)



7.6. TEST RESULTS

Model No.	AOP-8060XT	Test Mode	Mode 1
Environmental Conditions	29deg.C, 50% RH, 1010 hPa	6dB BANDWIDTH	120 KHz
Antenna Pole	Vertical	Antenna Distance	10m
Detector Function	Quasi-peak.	Tested by	Benson Yang

(The chart below shows the highest readings taken from the final data.)

Six Highest Radiated Emission Readings							
Frequency Range Investigated				30 MHz to 1000 MHz at 10m			
Freq (MHz)	Amptd (dBuV/m)	Margin (dB)	Limit (dBuV/m)	Reading (dBuV)	Factor (dB/m)	Reading Type (P/Q/A)	Pol. (H/V)
55.3300	35.13	-4.87	40.00	54.40	-19.27	Q	V
57.8350	32.83	-7.17	40.00	53.00	-20.17	Q	V
133.3150	28.44	-11.56	40.00	42.00	-13.56	Q	V
218.8150	25.78	-14.22	40.00	40.20	-14.42	Q	V
233.5000	33.32	-13.68	47.00	46.50	-13.18	Q	V
400.0200	30.26	-16.74	47.00	36.00	-5.74	Q	V

- REMARKS:**
1. 30MHz to 1000MHz test is Applicable CISPR 22 / EN 55022 standard.
 2. The other emission levels were very low against the limit.
 3. P= Peak Reading; Q= Quasi-peak Reading A= Average Reading.



Model No.	AOP-8060XT	Test Mode	Mode 1
Environmental Conditions	29deg.C, 50% RH, 1010 hPa	6dB BANDWIDTH	120 KHz
Antenna Pole	Horizontal	Antenna Distance	10m
Detector Function	Quasi-peak.	Tested by	Benson Yang

(The chart below shows the highest readings taken from the final data.)

Six Highest Radiated Emission Readings							
Frequency Range Investigated				30 MHz to 1000 MHz at 10m			
Freq (MHz)	Amptd (dBuV/m)	Margin (dB)	Limit (dBuV/m)	Reading (dBuV)	Factor (dB/m)	Reading Type (P/Q/A)	Pol. (H/V)
67.9100	27.69	-12.31	40.00	48.10	-20.41	Q	H
70.4300	23.27	-16.73	40.00	43.50	-20.23	Q	H
181.0800	24.00	-16.00	40.00	39.80	-15.80	Q	H
400.0100	30.46	-16.54	47.00	36.20	-5.74	Q	H
509.2350	29.98	-17.02	47.00	33.60	-3.62	Q	H
598.5000	31.56	-15.44	47.00	33.00	-1.44	Q	H

- REMARKS:**
1. 30MHz to 1000MHz test is Applicable CISPR 22 / EN 55022 standard.
 2. The other emission levels were very low against the limit.
 3. P= Peak Reading; Q= Quasi-peak Reading A= Average Reading.

**8 PHOTOGRAPHS OF THE TEST CONFIGURATION
CONDUCTED EMISSION TEST**



RADIATED EMISSION TEST

