

FCC Verification TEST REPORT

for

Fanless Embedded Controller

MODEL: xxxxxAEC-6811-xxxxxxx

Test Report Number:
90525201-F

Issued to:

AAEON Technology Inc.

**5F, No. 135, Lane 235, Pao Chiao Rd., Hsin-Tien City,
Taipei, Taiwan, R.O.C.**

Issued by:

Compliance Certification Services Inc.

Sindian BU.

**No.163-1, Jhongsheng Rd., Sindian City,
Taipei County 23151, Taiwan**

TEL: 886-2-22170894

FAX: 886-2-22171029

Issued Date: June 2, 2009



Note: This report shall not be reproduced except in full, without the written approval of Compliance Certification Services Inc. This document may be altered or revised by Compliance Certification Services Inc. personnel only, and shall be noted in the revision section of the document. The client should not use it to claim product endorsement by TAF, A2LA, NVLAP, NIST or any government agencies. The test results in the report only apply to the tested sample.



Revision History

| Rev. | Issue Date | Revisions | Effect Page | Revised By |
|------|------------|---------------|-------------|------------|
| 00 | | Initial Issue | ALL | |
| | | | | |
| | | | | |
| | | | | |



TABLE OF CONTENTS

1 TEST RESULT CERTIFICATION..... 4

2 EUT DESCRIPTION..... 5

3 TEST METHODOLOGY 6

3.1. DECISION OF FINAL TEST MODE..... 6

3.2. EUT SYSTEM OPERATION 6

4 SETUP OF EQUIPMENT UNDER TEST 7

4.1. DESCRIPTION OF SUPPORT UNITS 7

4.2. CONFIGURATION OF SYSTEM UNDER TEST..... 8

5 FACILITIES AND ACCREDITATIONS 9

5.1. FACILITIES 9

5.2. ACCREDITATIONS 9

5.3. MEASUREMENT UNCERTAINTY 9

6 CONDUCTED EMISSION MEASUREMENT..... 10

6.1. LIMITS OF CONDUCTED EMISSION MEASUREMENT 10

6.2. TEST INSTRUMENTS 10

6.3. TEST PROCEDURES 11

6.4. TEST SETUP 12

6.5. DATA SAMPLE..... 12

6.6. TEST RESULTS..... 12

7 RADIATED EMISSION MEASUREMENT 13

7.1. LIMITS OF RADIATED EMISSION MEASUREMENT 13

7.2. TEST INSTRUMENTS 13

7.3. TEST PROCEDURES 14

7.4. TEST SETUP 15

7.5. DATA SAMPLE..... 16

7.6. TEST RESULTS..... 17

8 PHOTOGRAPHS OF THE TEST CONFIGURATION 19



1 TEST RESULT CERTIFICATION

Product: Fanless Embedded Controller

Model: xxxxxAEC-6811-xxxxxxx (Where x is 0-9, A-Z, - or blank)

Brand: AAEON

Applicant: **AAEON Technology Inc.**
5F, No. 135, Lane 235, Pao Chiao Rd., Hsin-Tien City,
Taipei, Taiwan, R.O.C.

Manufacturer: **AAEON Technology Inc.**
5F, No. 135, Lane 235, Pao Chiao Rd., Hsin-Tien City,
Taipei, Taiwan, R.O.C.

Tested: May 22, 2009 & May 26, 2009

| EMISSION | | | |
|--|-----------------------|--------|------------------------|
| Standard | Item | Result | Remarks |
| FCC 47 CFR Part 15 Subpart B, ICES-003 Issue 4 ANSI C63.4-2003 | Conducted (Main Port) | N/A | Please see the page 12 |
| | Radiated | PASS | Meet Class A limit |

Note: 1. The statements of test result on the above are decided by the request of test standard only; the measurement uncertainties are not factored into this compliance determination.
2. The information of measurement uncertainty is available upon the customer's request.

| Deviation from Applicable Standard |
|------------------------------------|
| None |

The above equipment has been tested by Compliance Certification Services Inc., and found compliance with the requirements set forth in the technical standards mentioned above. The results of testing in this report apply only to the product/system, which was tested. Other similar equipment will not necessarily produce the same results due to production tolerance and measurement uncertainties.

Approved by:

Reviewed by:

Vince Chiang
Assistant Manager of Sindian BU.

Vesta Hsu
Supervisor of report document dept. of Sindian BU.



2 EUT DESCRIPTION

| | |
|------------------------------|--|
| Product | Fanless Embedded Controller |
| Brand Name | AAEON |
| Model | xxxxxAEC-6811-xxxxxxx (Where x is 0-9, A-Z, - or blank) |
| Applicant | AAEON Technology Inc. |
| Housing material | Metal case |
| Identify Number | 90525201 |
| Received Date | May 25, 2009 |
| EUT Power Rating | 12VDC from Adaptor |
| EUT I/O Cable Type | Audio: Unshielded, 0.2m (Detachable) PS/2: Shielded, 0.15m (Detachable) |
| OSC/Clock Frequencies | 14.31818MHz; 25MHz; 32.768KHz; 24.576MHz |

I/O PORT

| I/O PORT TYPES | Q'TY | TESTED WITH |
|-------------------------------|------|-------------|
| 1. SIO Port | 4 | 4 |
| 2. VGA Port | 1 | 1 |
| 3. PS/2 one to two adaptor | 1 | 1 |
| 4. Audio one to three adaptor | 1 | 1 |
| 5. USB Port | 4 | 4 |
| 6. LAN Port | 2 | 2 |
| 7. CF Slot | 1 | 1 |
| 8. DIO port | 1 | 1 |

Note: Client consigns only one model sample to test (Model Number: AEC-6811).

3 TEST METHODOLOGY

3.1. DECISION OF FINAL TEST MODE

The EUT was tested together with the above additional components, and a configuration, which produced the worst emission levels, was selected and recorded in this report.

The test configuration/ mode is as the following:

Radiation Mode:

| | |
|----|----------------------|
| 1. | Normal Mode |
| | Normal Mode / 1-5GHz |

Conduction: N/A *(The subject equipment is not intended to be connected to AC mains supply. Therefore, this test is not applicable)*

Radiation: Mode 1

3.2. EUT SYSTEM OPERATION

1. Windows XP boots system.
2. Run Emctest.exe to activate all peripherals and display “H” pattern on monitor screen.
3. Run Winemc.exe and choose media player to play music.
4. Run Winemc.exe and choose “E:/ & F:/ & G:/ & H:/” to test USB port.
5. Run Winemc.exe and choose “I:/” to test CF slot.
6. Press the start menu, select executive and type ping 192.168.2.10 -t (EUT), ping 192.168.2.20 -t (EUT), ping 192.168.2.11 -t (Server Notebook).

Note: Test program is self-repeating throughout the test.



4 SETUP OF EQUIPMENT UNDER TEST

4.1. DESCRIPTION OF SUPPORT UNITS

The EUT has been tested as an independent unit together with other necessary accessories or support units. The following support units or accessories were used to form a representative test configuration during the tests.

EUT Devices:

| No. | Equipment | Model No. | Trade Name |
|-----|----------------|------------------|------------|
| 1 | CPU (500MHz) | Geode LX | AMD |
| 2 | Memory (512MB) | V58C2512804SAI5I | Apacer |
| 3 | HDD (40GB) | MHW2040AT | FUJITSU |

Peripherals Devices:

| No. | Equipment | Model No. | Serial No. | FCC ID / BSMI ID | Trade Name | Data Cable | Power Cord |
|-------|-----------------------|----------------|-----------------|---------------------|------------|----------------------------------|------------------------------------|
| 1~4 | USB HDD | F12-U | N/A | BSMI ID: 4912A002 | TeraSys | Shielded, 1.8m | N/A |
| 5 | PS/2 Mouse | M071KC | 443029438 | DOC BSMI: R41108 | DELL | Shielded, 1.8m | N/A |
| 6 | PS/2 Keyboard | SK-8110 | N/A | DOC BSMI: T3A002 | DELL | Shielded, 1.8m | N/A |
| 7 | Earphone & Microphone | MSB301 | N/A | N/A | e-Sense | Unshielded, 1.8m | N/A |
| 8 | Player | RQ-L11LT | N/A | BSMI ID: 3912A162 | Panasonic | Unshielded, 1.8m | N/A |
| 9 | Monitor | 710V | GS17H9NXA05858E | DOC BSMI: R33475 | SAMAUNG | Shielded, 1.8m with two cores | Unshielded, 1.8m |
| 10~13 | Modem | 1414 | N/A | IFAXDM1414 | ACEEX | Shielded, 1.2m | Unshielded, 1.8m |
| 14 | Hub | DGS-1008D | N/A | N/A | D-Link | Unshielded, 20m X2 | Unshielded, 1.8m with a core |
| 15 | Server Notebook | 2210B | CNV7472KG5 | DOC BSMI: R33001 | HP | Unshielded, 1.0m | Unshielded, 1.8m |
| 16 | DIO Cable | N/A | N/A | N/A | N/A | Unshielded, 1.8m X2 | N/A |
| 17 | CF Card | N/A | N/A | N/A | N/A | N/A | N/A |
| 18 | Power Adaptor | FSP036-1AD101C | N/A | N/A | FSP | Unshielded, 1.0m with a core | Unshielded, 1.8m |

Note:

- 1) All the equipment/cables were placed in the worst-case configuration to maximize the emission during the test.
- 2) Grounding was established in accordance with the manufacturer's requirements and conditions for the intended use.

4.2. CONFIGURATION OF SYSTEM UNDER TEST

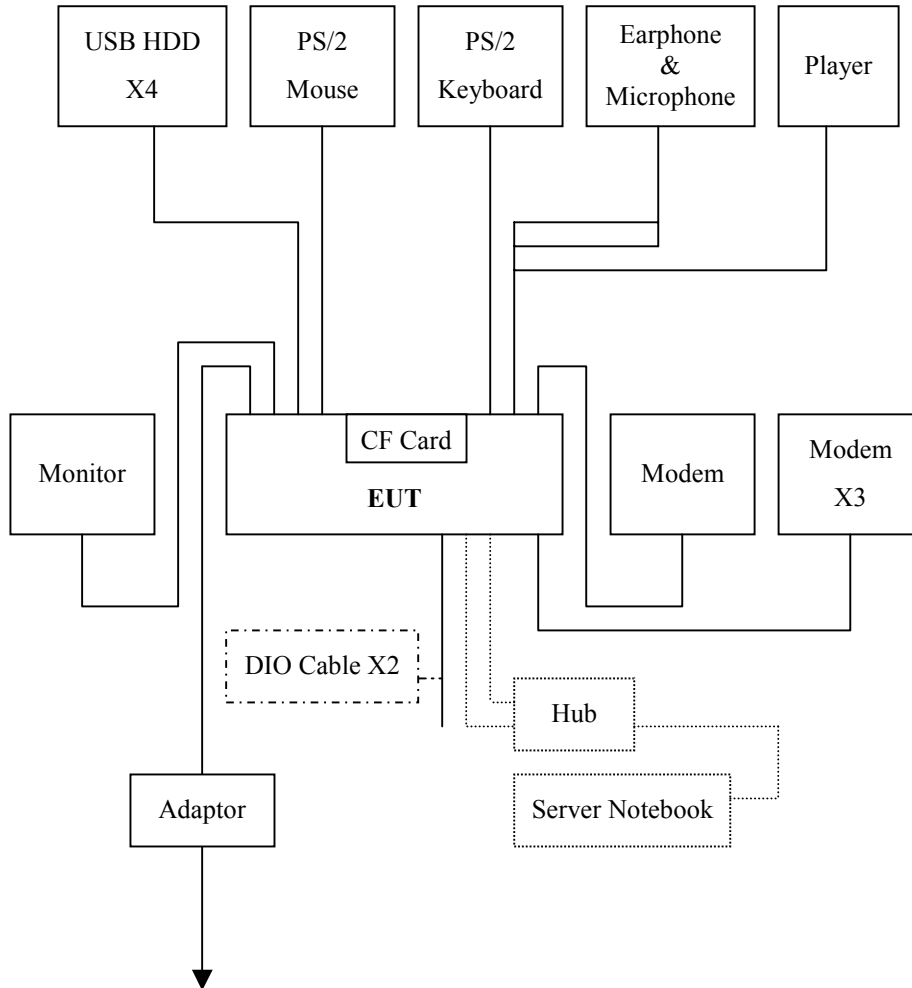

5 FACILITIES AND ACCREDITATIONS

5.1. FACILITIES

All measurement facilities used to collect the measurement data are located at CCS Taiwan Sindian BU. at No.163-1, Jhongsheng Rd., Sindian City, Taipei County 23151, Taiwan.

The sites are constructed in conformance with the requirements of ANSI C63.4 and CISPR Publication 22. All receiving equipment conforms to CISPR 16-1-1, CISPR 16-1-2, CISPR 16-1-3, CISPR 16-1-4 and CISPR 16-1-5.

5.2. ACCREDITATIONS

Our laboratories are accredited and approved by the following accreditation body according to ISO/IEC 17025.

| | |
|---------------|------|
| Taiwan | TAF |
| USA | A2LA |

The measuring facility of laboratories has been authorized or registered by the following approval agencies.

| | |
|----------------|-----------------|
| Canada | Industry Canada |
| Germany | TUV Rheinland |
| Japan | VCCI |
| Taiwan | BSMI |
| USA | FCC |

Copies of granted accreditation certificates are available for downloading from our web site, <http://www.ccsemc.com>

5.3. MEASUREMENT UNCERTAINTY

Where relevant, the following measurement uncertainty levels have been estimated for tests performed on the EUT as specified in CISPR 16-4-2:

| Measurement | Frequency | Uncertainty |
|---------------------|-----------------|-------------|
| Conducted emissions | 0.15MHz~30MHz | N/A |
| Radiated emissions | 30MHz ~ 200MHz | ± 3.8792 |
| | 200MHz ~1000MHz | ± 3.8914 |

This uncertainty represents an expanded uncertainty expressed at approximately the 95% confidence level using a coverage factor of k=2.

Consistent with industry standard (e.g. CISPR 22: 2006, clause 11, Measurement Uncertainty) determining compliance with the limits shall be base on the results of the compliance measurement. Consequently the measure emissions being less than the maximum allowed emission result in this be a compliant test or passing test.

The acceptable measurement uncertainty value without requiring revision of the compliance statement is base on conducted and radiated emissions being less than U_{CISPR} which is 3.6dB and 5.2dB respectively. CCS values (called U_{Lab} in CISPR 16-4-2) is less than U_{CISPR} as shown in the table above. Therefore, MU need not be considered for compliance.



6 CONDUCTED EMISSION MEASUREMENT

6.1. LIMITS OF CONDUCTED EMISSION MEASUREMENT

| FREQUENCY (MHz) | Class A (dBuV) | | Class B (dBuV) | |
|-----------------|----------------|---------|----------------|---------|
| | Quasi-peak | Average | Quasi-peak | Average |
| 0.15 - 0.5 | 79 | 66 | 66 - 56 | 56 - 46 |
| 0.50 - 5.0 | 73 | 60 | 56 | 46 |
| 5.0 - 30.0 | 73 | 60 | 60 | 50 |

NOTE:

- (1) The lower limit shall apply at the transition frequencies.
- (2) The limit decreases in line with the logarithm of the frequency in the range of 0.15 to 0.50 MHz.
- (3) All emanations from a class A/B digital device or system, including any network of conductors and apparatus connected thereto, shall not exceed the level of field strengths specified above.

6.2. TEST INSTRUMENTS

| Conducted Emission Room # | | | | |
|---------------------------|--------------|-------|---------------|-----------------|
| Name of Equipment | Manufacturer | Model | Serial Number | Calibration Due |
| | | | | |
| | | | | |
| | | | | |
| | | | | |
| | | | | |
| | | | | |
| | | | | |

- NOTE:** 1. The calibration interval of the above test instruments is 12 months and the calibrations are traceable to NML/ROC and NIST/USA.
 2. N.C.R = No Calibration Request.



6.3. TEST PROCEDURES (please refer to measurement standard or CCS SOP PA-031)

Procedure of Preliminary Test

- The EUT and Support equipment, if needed, was set up as per the test configuration to simulate typical usage per the user's manual. When the EUT is a tabletop system, a wooden table with a height of 0.8 meters is used and is placed on the ground plane as per ANSI C63.4 (see Test Facility for the dimensions of the ground plane used). When the EUT is a floor standing equipment, it is placed on the ground plane, which has a 12 mm non-conductive covering to insulate the EUT from the ground plane.
- All I/O cables were positioned to simulate typical actual usage as per ANSI C63.4.
- The test equipment EUT installed received AC main power, through a Line Impedance Stabilization Network (LISN), which supplied power source and was grounded to the ground plane.
- All support equipment power received from a second LISN.
- The EUT test program was started. Emissions were measured on each current carrying line of the EUT using an EMI Test Receiver connected to the LISN powering the EUT.
- The Receiver scanned from 150kHz to 30MHz for emissions in each of the test modes.
- During the above scans, the emissions were maximized by cable manipulation.
- The test mode(s) described in Item 3.1 were scanned during the preliminary test.
- After the preliminary scan, we found the test mode described in Item 3.1 producing the highest emission level.
- The EUT configuration and cable configuration of the above highest emission levels were recorded for reference of the final test.

Procedure of Final Test

- EUT and support equipment were set up on the test bench as per the configuration with highest emission level in the preliminary test.
- A scan was taken on both power lines, Line 1 and Line 2, recording at least the six highest emissions. Emission frequency and amplitude were recorded into a computer in which correction factors were used to calculate the emission level and compare reading to the applicable limit.
- The test data of the worst-case condition(s) was recorded.

6.4. TEST SETUP

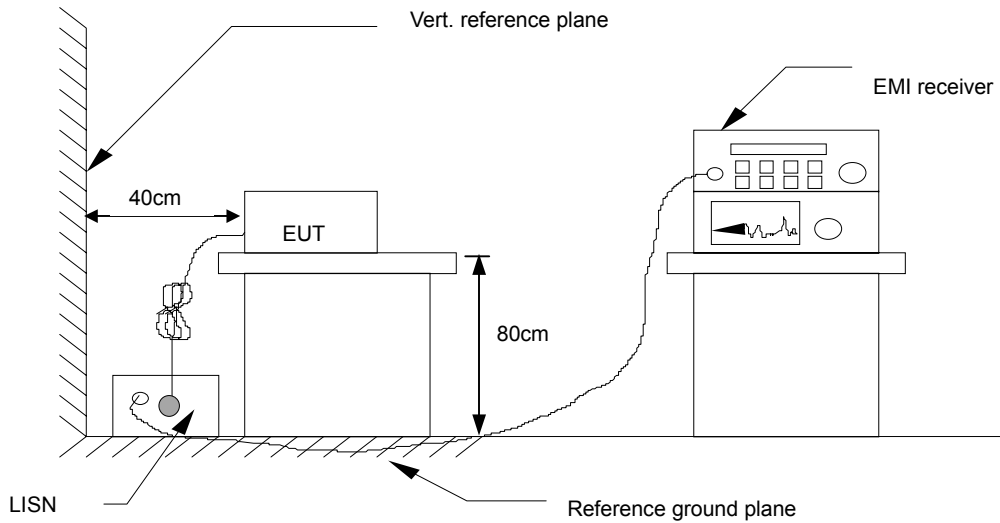

- For the actual test configuration, please refer to the related item – Photographs of the Test Configuration.

6.5. DATA SAMPLE

| Freq. (MHz) | Read Level (dBuV) | Factor (dB) | Level (dBuV) | Limit Line (dBuV) | Over Limit (dB) | Remark (P/Q/A) | Line (L1/L2) |
|-------------|-------------------|-------------|--------------|-------------------|-----------------|----------------|--------------|
| x.xx | 42.95 | 0.55 | 43.50 | 73 | -29.50 | Q | L1 |

- Freq. = Emission frequency in MHz
- Read Level = Uncorrected Analyzer/Receiver reading
- Factor = Insertion loss of LISN + Cable Loss
- Level = Read Level + Factor
- Limit Line = Limit stated in standard
- Over Limit = Reading in reference to limit
- P = Peak Reading
- Q = Quasi-peak Reading
- A = Average Reading
- L1 = Hot side
- L2 = Neutral side

Calculation Formula

Over Limit (dB) = Level (dBuV) – Limit Line (dBuV)

6.6. TEST RESULTS

| | | | |
|---------------------------------|-----|----------------------|-----|
| Model No. | N/A | 6dB Bandwidth | N/A |
| Environmental Conditions | N/A | Test Mode | N/A |
| Tested by | N/A | | |

NOTE: The subject equipment is not intended to be connected to AC mains supply. Therefore, this test is not applicable.



7 RADIATED EMISSION MEASUREMENT

7.1. LIMITS OF RADIATED EMISSION MEASUREMENT

| FREQUENCY (MHz) | dBuV/m (At 10m) | |
|-----------------|-----------------|---------|
| | Class A | Class B |
| 30 ~ 230 | 40 | 30 |
| 230 ~ 1000 | 47 | 37 |

| Frequency (MHz) | Class A (dBuV/m) (At 3m) | | Class B (dBuV/m) (At 3m) | |
|-----------------|--------------------------|------|--------------------------|------|
| | Average | Peak | Average | Peak |
| Above 1000 | 60 | 80 | 54 | 74 |

NOTE: (1) The lower limit shall apply at the transition frequencies.
 (2) Emission level (dBuV/m) = 20 log Emission level (uV/m).
 (3) 10m to 3m: 20 log (3/10)=-10.4576dB.

7.2. TEST INSTRUMENTS

| Open Area Test Site # I | | | | |
|--------------------------------|---------------|--------------|---------------|-------------------------|
| Name of Equipment | Manufacturer | Model | Serial Number | Calibration Due |
| MEASURE RECEIVER | SCHAFFNER | SCR3501 | 338 | 07/07/2009 |
| SPECTRUM ANALYZER | ADVANTEST | R3132 | 120900008 | No Calibration Required |
| ANTENNA | SCHAFFNER | CBL 6112B | 2809 | 09/08/2009 |
| AMPLIFIER | SCHAFFNER | CPA9231A | 3626 | 10/12/2009 |
| CABLE | BELDEN | 9913 | N-TYPE #I2 | 02/22/2010 |
| THERMO-HYGRO METER | TECPEL | DTM-303 | 090639 | 05/21/2010 |
| Test S/W | Lab VIEW 7.1 | | | |
| Above 1GHz Used | | | | |
| SPECTRUM ANALYZER (9kHz-30GHz) | R&S | FSP 30 | 100112 | 10/16/2009 |
| ANTENNA (1-18GHz) | EMCO | 3115 | 00022256 | 01/22/2010 |
| AMPLIFIER (1-18GHz) | HP | 8449B | 3008A01266 | 01/19/2010 |
| CABLE (1-18GHz) | JYEBAO | LL142 | SMA#RS1 | 01/19/2010 |
| CABLE (1-18GHz) | HUBER +SUHNER | SUCOFLEX 104 | SMA#RS3 | 01/19/2010 |
| CABLE (1-18GHz) | JYEBAO | LL142 | SMA#C1 | 01/19/2010 |
| Test S/W | EZ-EMC | | | |

NOTE: 1. The calibration interval of the above test instruments is 12 months and the calibrations are traceable to NML/ROC and NIST/USA.
 2. N.C.R = No Calibration Request.



7.3. TEST PROCEDURES (please refer to measurement standard or CCS SOP PA-031)

Procedure of Preliminary Test

- The equipment was set up as per the test configuration to simulate typical usage per the user's manual. When the EUT is a tabletop system, a wooden turntable with a height of 0.8 meters is used which is placed on the ground plane. When the EUT is a floor standing equipment, it is placed on the ground plane which has a 12 mm non-conductive covering to insulate the EUT from the ground plane.
- Support equipment, if needed, was placed as per ANSI C63.4.
- All I/O cables were positioned to simulate typical usage as per ANSI C63.4.
- The EUT received AC power source from the outlet socket under the turntable. All support equipment power received from another socket under the turntable.
- The antenna was placed at 10/3 meter away from the EUT as stated in ANSI C63.4. The antenna connected to the Spectrum Analyzer via a cable and at times a pre-amplifier would be used.
- The Analyzer / Receiver quickly scanned from 30MHz to 5000MHz. The EUT test program was started. Emissions were scanned and measured rotating the EUT to 360 degrees and positioning the antenna 1 to 4 meters above the ground plane, in both the vertical and the horizontal polarization, to maximize the emission reading level.
- The test mode(s) described in Item 3.1 were scanned during the preliminary test:
- After the preliminary scan, we found the test mode described in Item 3.1 producing the highest emission level.
- The EUT and cable configuration, antenna position, polarization and turntable position of the above highest emission level were recorded for the final test.

Procedure of Final Test

- EUT and support equipment were set up on the turntable as per the configuration with highest emission level in the preliminary test.
- The Analyzer / Receiver scanned from 30MHz to 5000MHz. Emissions were scanned and measured rotating the EUT to 360 degrees, varying cable placement and positioning the antenna 1 to 4 meters above the ground plane, in both the vertical and the horizontal polarization, to maximize the emission reading level.
- Recorded at least the six highest emissions. Emission frequency, amplitude, antenna position, polarization and turntable position were recorded into a computer in which correction factors were used to calculate the emission level and compare reading to the applicable limit and only Q.P. reading is presented.
- The test data of the worst-case condition(s) was recorded.

7.4. TEST SETUP

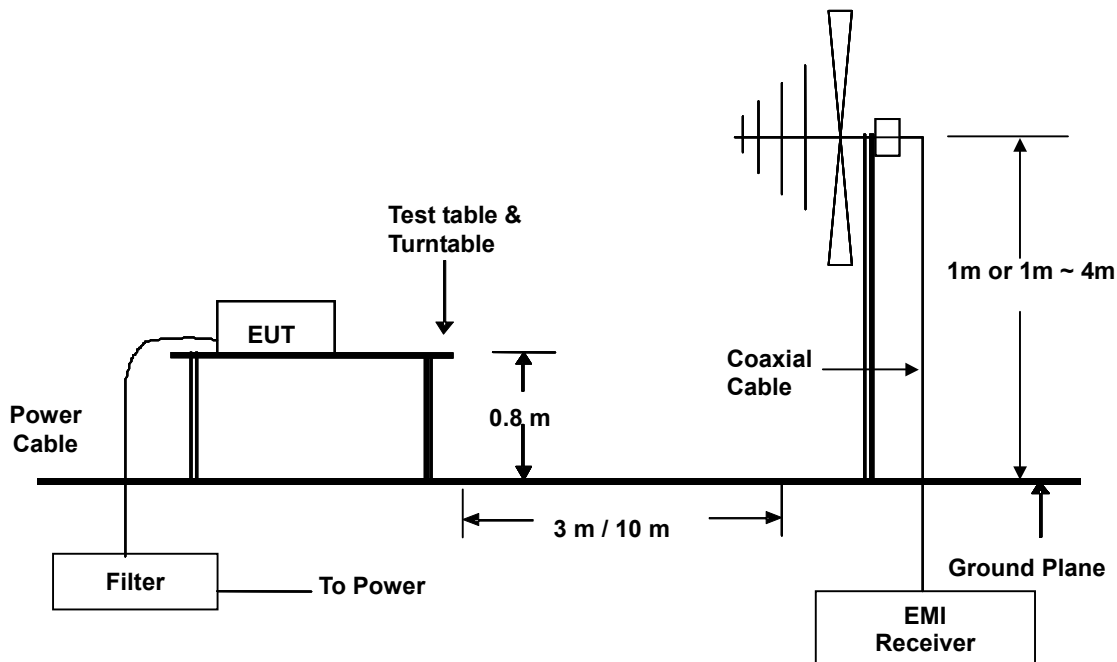

- For the actual test configuration, please refer to the related item - Photographs of the Test Configuration.



7.5. DATA SAMPLE

Below 1GHz

| Freq. (MHz) | Reading (dBuV/m) | Factor (dB) | Result (dBuV/m) | Limit (dBuV/m) | Margin (dB) | Remark (P/Q) | Pol. (H/V) |
|-------------|------------------|-------------|-----------------|----------------|-------------|--------------|------------|
| x.xx | 14.0 | 12.2 | 26.2 | 40 | -13.8 | Q | H |

- Freq. = Emission frequency in MHz
- Reading = Uncorrected Analyzer/Receiver reading
- Factor = Antenna Factor + Cable Loss + Attenuator (3/6/10dB) – Amplifier Gain
- Result = Reading + Factor
- Limit = Limit stated in standard
- Margin = Reading in reference to limit
- P = Peak Reading
- Q = Quasi-peak Reading
- H = Antenna Polarization: Horizontal
- V = Antenna Polarization: Vertical

Calculation Formula

Margin (dB) = Result (dBuV/m) – Limit (dBuV/m)

Above 1GHz

| Freq. (MHz) | Reading (dBuV) | Factor (dB) | Result (dBuV/m) | Limit (dBuV/m) | Margin (dB) | Detector (P/A) | Pol. (H/V) |
|-------------|----------------|-------------|-----------------|----------------|-------------|----------------|------------|
| x.xx | 42.95 | 0.55 | 43.50 | 60 | -16.50 | A | H |

- Freq. = Emission frequency in MHz
- Reading = Uncorrected Analyzer/Receiver reading
- Factor = Antenna Factor + Cable Loss - Amplifier Gain
- Result = Reading + Factor
- Limit = Limit stated in standard
- Margin = Result – Limit
- P = Peak Reading
- A = Average Reading
- H = Antenna Polarization: Horizontal
- V = Antenna Polarization: Vertical



7.6. TEST RESULTS

Below 1GHz

| | | | |
|---------------------------------|---------------------------|-------------------------|-------------|
| Model No. | AEC-6811 | Test Mode | Mode 1 |
| Environmental Conditions | 25deg.C, 80% RH, 1010 hPa | 6dB Bandwidth | 120 KHz |
| Antenna Pole | Vertical / Horizontal | Antenna Distance | 10m |
| Remark Function | Quasi-peak. | Tested by | Howard Peng |

(The chart below shows the highest readings taken from the final data.)

| Six Highest Radiated Emission Readings | | | | | | | |
|--|----------------|-------------|-----------------|---------------------------|-------------|--------------|------------|
| Frequency Range Investigated | | | | 30 MHz to 1000 MHz at 10m | | | |
| Freq. (MHz) | Reading (dBuV) | Factor (dB) | Result (dBuV/m) | Limit (dBuV/m) | Margin (dB) | Remark (P/Q) | Pol. (H/V) |
| 62.979 | 51.30 | -22.40 | 28.90 | 40.00 | -11.10 | Q | V |
| 72.000 | 55.10 | -21.85 | 33.25 | 40.00 | -6.75 | Q | V |
| 120.003 | 45.70 | -15.90 | 29.80 | 40.00 | -10.20 | Q | V |
| 199.953 | 54.60 | -18.19 | 36.41 | 40.00 | -3.59 | Q | V |
| 216.004 | 44.90 | -17.81 | 27.09 | 40.00 | -12.91 | Q | V |
| 552.010 | 44.10 | -6.01 | 38.09 | 47.00 | -8.91 | Q | V |

(The chart below shows the highest readings taken from the final data.)

| Six Highest Radiated Emission Readings | | | | | | | |
|--|----------------|-------------|-----------------|---------------------------|-------------|--------------|------------|
| Frequency Range Investigated | | | | 30 MHz to 1000 MHz at 10m | | | |
| Freq. (MHz) | Reading (dBuV) | Factor (dB) | Result (dBuV/m) | Limit (dBuV/m) | Margin (dB) | Remark (P/Q) | Pol. (H/V) |
| 72.003 | 49.30 | -21.85 | 27.45 | 40.00 | -12.55 | Q | H |
| 199.952 | 51.50 | -18.19 | 33.31 | 40.00 | -6.69 | Q | H |
| 216.010 | 45.30 | -17.81 | 27.49 | 40.00 | -12.51 | Q | H |
| 504.010 | 42.80 | -7.68 | 35.12 | 47.00 | -11.87 | Q | H |
| 551.990 | 48.20 | -6.01 | 42.19 | 47.00 | -4.81 | Q | H |
| 999.776 | 37.10 | -1.45 | 35.65 | 47.00 | -11.35 | Q | H |

- REMARKS:**
1. 30MHz to 1000MHz test is Applicable CISPR 22 / EN 55022 standard.
 2. The other emission levels were very low against the limit.
 3. P= Peak Reading; Q= Quasi-peak Reading



Above 1GHz

| | | | |
|---------------------------------|------------------------|-------------------------|-----------|
| Model No. | AEC-6811 | Test Mode | Mode 1 |
| Environmental Conditions | 26°C, 60% RH, 1010mbar | 6dB Bandwidth | 1000 KHz |
| Antenna Pole | Vertical / Horizontal | Antenna Distance | 3m |
| Detector Function | Peak or Average | Tested by | Alee Shen |

(The chart below shows the highest readings taken from the final data.)

| Six Highest Radiated Emission Readings | | | | | | | |
|--|----------------|-------------|-----------------|----------------------------|-------------|----------------|------------|
| Frequency Range Investigated | | | | 1000 MHz to 5000 MHz at 3m | | | |
| Freq. (MHz) | Reading (dBuV) | Factor (dB) | Result (dBuV/m) | Limit (dBuV/m) | Margin (dB) | Detector (P/A) | Pol. (H/V) |
| 1204.000 | 53.87 | -10.48 | 43.39 | 80.00 | -36.61 | P | V |
| 1374.000 | 51.35 | -9.63 | 41.72 | 80.00 | -38.28 | P | V |
| 1748.000 | 56.03 | -7.46 | 48.57 | 80.00 | -31.43 | P | V |
| 2054.000 | 51.33 | -5.73 | 45.60 | 80.00 | -34.40 | P | V |
| 2428.000 | 50.41 | -4.53 | 45.88 | 80.00 | -34.12 | P | V |
| 3006.000 | 51.55 | -2.18 | 49.37 | 80.00 | -30.63 | P | V |

(The chart below shows the highest readings taken from the final data.)

| Six Highest Radiated Emission Readings | | | | | | | |
|--|----------------|-------------|-----------------|----------------------------|-------------|----------------|------------|
| Frequency Range Investigated | | | | 1000 MHz to 5000 MHz at 3m | | | |
| Freq. (MHz) | Reading (dBuV) | Factor (dB) | Result (dBuV/m) | Limit (dBuV/m) | Margin (dB) | Detector (P/A) | Pol. (H/V) |
| 1646.000 | 52.42 | -8.09 | 44.33 | 80.00 | -35.67 | P | H |
| 2224.000 | 51.21 | -5.18 | 46.03 | 80.00 | -33.97 | P | H |
| 2598.000 | 47.15 | -3.89 | 43.26 | 80.00 | -36.74 | P | H |
| 3006.000 | 50.46 | -2.18 | 48.28 | 80.00 | -31.72 | P | H |
| 3414.000 | 52.20 | -1.04 | 51.16 | 80.00 | -28.84 | P | H |
| 4162.000 | 49.58 | 0.93 | 50.51 | 80.00 | -29.49 | P | H |

REMARKS: 1. The other emission levels were very low against the limit.
2. P= Peak Reading; A= Average Reading

8 PHOTOGRAPHS OF THE TEST CONFIGURATION

RADIATED EMISSION TEST

