

FCC CLASS A COMPLIANCE REPORT

for

Electromagnetic Emissions

of

CPU Board

Trade Name : N/A

Model Number : PCM-6890B(N)

Serial Number : N/A

Report Number : 000461-F

Date : July 18, 2000

Prepared for :

AAEON Technology Co., Ltd.

**5F, No. 135, Lane 235, Pao Chiao Rd. Hsin-Tien City,
Taipei, Taiwan, R.O.C.**

Prepared by :

C&C LABORATORY, CO., LTD.

**1st, Fl, No. 344, Fu Ching Street,
Taipei, Taiwan, R.O.C.**

TEL: (02)2746-8584

FAX: (02)2763-2154



**This report shall not be reproduced, except in full, without the written approval of
C&C Laboratory, Co., Ltd.**



TABLE OF CONTENTS

DESCRIPTION	PAGE
VERIFICATION OF COMPLIANCE	3
SYSTEM DESCRIPTION	4
PRODUCT INFORMATION	5
SUPPORT EQUIPMENT	6
MEASUREMENT PROCEDURE & LIMIT (LINE CONDUCTED EMISSION TEST)	7
MEASUREMENT PROCEDURE & LIMIT (RADIATED EMISSION TEST)	9
SUMMARY DATA	12
APPENDIX 1 TEST FACILITY	19
APPENDIX 2 TEST EQUIPMENT	21
APPENDIX 3 BLOCK DIAGRAM OF TEST SETUP	25
APPENDIX 4 PHOTOGRAPHS OF TEST SETUP	27
APPENDIX 5 PHOTOGRAPHS OF EUT	30



VERIFICATION OF COMPLIANCE

Equipment Under Test: CPU Board

Trade Name: N/A

Model Number: PCM-6890B(N)

Serial Number: N/A

Applicant: **AAEON Technology Co., Ltd.**
5F, No.135, Lane 235, Pao Chiao Rd. Hsin-Tien City,
Taipei, Taiwan, R.O.C.

Manufacturer: **AAEON Technology Co., Ltd.**
5F, No.135, Lane 235, Pao Chiao Rd. Hsin-Tien City,
Taipei, Taiwan, R.O.C.

Type of Test: FCC Class A

Measurement Procedure: ANSI C63.4: 1992

File Number: 000461-F

Date of test: July 8~10, 2000

Deviation: According to applicant's declaration this EUT is a class A product, and to be market in industrial environment only.

Condition of Test Sample: Normal

The above equipment was tested by C&C Laboratory, Co., Ltd. for compliance with the requirements set forth in the FCC Rules and Regulations Part 15, Subpart B and the measurement procedure according to ANSI C63.4, 1992. This said equipment in the configuration described in this report shows the maximum emission levels emanating from equipment are within the compliance requirements.

The test results of this report relate only to the tested sample identified in this report.

Responsible Party

Kuo Chen

Authorized Signatory

Officer of the Responsible Party



SYSTEM DESCRIPTION

EUT Test Program:

1. An EMI test software was loaded and executed under Windows environment.
2. The EMI test program sequentially exercised all I/O's of EUT.
3. A communicated software was loaded and executed on EUT to communicate with remote side equipment.
4. The EUT sends to and receives message from remote side, and filling the screen of monitor with upper case of "H" patterns.
5. Repeat step 2 to 4 throughout the test.



PRODUCT INFORMATION

Housing Type:	N/A		
EUT Power Rating:	DCV from Power Supply		
AC power during Test:	120VAC/60Hz to Power Supply		
Power Supply Manufacturer:	AAEON		
Power Supply Model Number:	ENP-1815		
AC Power Cord Type:	Unshielded, 1.8m (Detachable) to Power Supply		
DC Power Cable Type:	N/A		
CPU Manufacturer:	Intel	Type:	Celeron 533MHz
OSC/Clock Frequencies:	66 MHz		
Memory Capacity:		Installed:	32MB
HDD Manufacturer:	MAXTOR	Model:	9108005
Case Manufacturer:	AAEON	Model:	ARC-6100B
VGA Card Type:	On Board		

Note: The manufacturer must list all items and the manipulation for compliance FCC requirement in the user' s manual.

I/O Port of EUT:

I/O PORT TYPES	Q' TY	TESTED WITH
1). Parallel Port	1	1
2). Serial Port	4	4
3). Video Port	1	1
4). PS/2 Keyboard Port	1	1
5). PS/2 Mouse	1	1
6). Microphone Port	1	1
7). Line-in Port	1	1
8). Line-out Port	1	1
9). TV-out (S terminal)	1	1
10).TV-out (AV terminal)	1	1
11).LAN Port	1	1
12).USB Port	2	2
13).AT Keyboard Port	1	1



SUPPORT EQUIPMENT

No.	Equipment	Model #	Serial #	FCC ID	Trade Name	Data Cable	Power Cord
1.	Monitor	GM753ET	T9B000194	DoC	HITACHI	Shielded, 1.5m	Unshielded, 1.8m
2.	TV	21S3	70332865	N/A	TOSHIBA	Shielded, 1.5m	Unshielded, 1.5m
3.	Modem	2400	94-364-176272	DK467GSM24	Computer Peripherals	Shielded, 1.8m	Unshielded, 1.5m
4.	Printer	2225C	3125S98198	DSI6XU2225	HP	Shielded, 1.8m	AC I/P: Unshielded, 1.5m
5.	PS/2 Keyboard	6511-TW4C	16600704C83G00 671S0000	N/A	ACER	Shielded, 1.8m	N/A
6.	AT Keyboard	KB-9000	KA5-2	LFCACEKEY1	ACEKEY	Shielded, 1.5m	N/A
7.	PS/2 Mouse	M-S43	LZE93401262	DZL211106	LOGITECH	Shielded, 1.8m	N/A
8.	USB Mouse	M-BB48	LZE93050165	DoC	LOGITECH	Shielded, 1.8m	N/A
9.	USB Mouse	M-BB48	LZE93050187	DoC	LOGITECH	Shielded, 1.8m	N/A
10.	Mouse	M-MM43	LZE94052771	DoC	LOGITECH	Shielded, 1.9m	N/A
11.	Mouse	M-MM43	LZE94052791	DoC	LOGITECH	Shielded, 1.9m	N/A
12.	Mouse	M-MM43	LZE93353074	DoC	LOGITECH	Shielded, 1.9m	N/A
13.	Walkman	YX-328	W7	N/A	YING-KO	Unshielded, 1.8m	N/A
14.	Multimedia Headset	SX-M	A5-2	N/A	TOKYO	Unshielded, 1.8m	N/A
15.	Notebook PC (Remote)	365	EXTENSA367T	FCC DoC	Acer	Shielded, 10m	N/A

Note: All the above equipment/cables were placed in worse case positions to maximize emission signals during emission test.

Grounding: Grounding was in accordance with the manufacturer's requirements and conditions for the intended use.



MEASUREMENT PROCEDURE (PRELIMINARY LINE CONDUCTED EMISSION TEST)

- 1) The equipment was set up as per the test configuration to simulate typical actual usage per the user's manual. When the EUT is a tabletop system, a wooden table with a height of 0.8 meters is used and is placed on the ground plane as per ANSI C63.4: 1992 (see Test Facility for the dimensions of the ground plane used). When the EUT is a floor-standing equipment, it is placed on the ground plane which has a 3-12 mm non-conductive covering to insulate the EUT from the ground plane.
- 2) Support equipment, if needed, was placed as per ANSI C63.4: 1992.
- 3) All I/O cables were positioned to simulate typical actual usage as per ANSI C63.4: 1992.
- 4) The EUT received AC power through a Line Impedance Stabilization Network (LISN) which supplied power source of 120VAC/60Hz and was grounded to the ground plane.
- 5) All support equipment received power from a second LISN supplying power of 110VAC/60Hz, if any.
- 6) The EUT test program was started. Emissions were measured on each current carrying line of the EUT using a spectrum Analyzer / Receiver connected to the LISN powering the EUT. The LISN has two monitoring points: Line 1 (Hot Side) and Line 2 (Neutral Side). Two scans were taken: one with Line 1 connected to Analyzer / Receiver and Line 2 connected to a 50 ohm load; the second scan had Line 1 connected to a 50 ohm load and Line 2 connected to the Analyzer / Receiver.
- 7) Analyzer / Receiver scanned from 150kHz to 30MHz for emissions in each of the test modes.
- 8) During the above scans, the emissions were maximized by cable manipulation.
- 9) The following test mode(s) were scanned during the preliminary test:

Mode(s): (Customer defined)

1. 1024 x 768 resolution with 533MHz CPU and 66MHz external clock + TV (AV in)
2. 800 x 600 resolution with 533MHz CPU and 66MHz external clock + TV (AV in)
3. 640 x 480 resolution with 533MHz CPU and 66MHz external clock + TV (AV in)

- 10) After the preliminary scan, we found the following test mode) producing the highest emission level.

Mode: 1.

Then, the EUT configuration and cable configuration of the above highest emission level were recorded for reference of final testing.



MEASUREMENT PROCEDURE (FINAL LINE CONDUCTED EMISSION TEST)

- 1) EUT and support equipment was set up on the test bench as per step 10 of the preliminary test.
- 2) A scan was taken on both power lines, Line 1 and Line 2, recording at least the six highest emissions. Emission frequency and amplitude were recorded into a computer in which correction factors were used to calculate the emission level and compare reading to the applicable limit.
- 3) The test data of the worst case condition(s) was reported on the Summary Data page.

Data Sample:

Freq. MHz	Q.P. Raw dBuV	Average Raw dBuV	Q.P. Limit dBuV	Average Limit dBuV	Q.P. Margin dB	Average Margin dB	Note
x.xx	39.2	---	79	66	-39.8	-26.8	L 1

- Freq. = Emission frequency in MHz
- Raw dBuV = Uncorrected Analyzer / Receiver reading
- Limit dBuV = Limit stated in standard
- Margin dB = Reading in reference to limit
- Note = Current carrying line of reading
- “---“ = The emission level complied with the Average limits, with at least 2 dB margin, so no further recheck.

LINE CONDUCTED EMISSION LIMIT

Frequency	Maximum RF Line Voltage	
	Q.P.	AVERAGE
150kHz-500kHz	79dBuV	66dBuV
500kHz-5MHz	73dBuV	60dBuV
5MHz-30MHz	73dBuV	60dBuV

Note: The lower limit shall apply at the transition frequency.

MEASUREMENT PROCEDURE (PRELIMINARY RADIATED EMISSION TEST)

- 1) The equipment was set up as per the test configuration to simulate typical actual usage per the user's manual. When the EUT is a tabletop system, a wooden turntable with a height of 0.8 meters is used which is placed on the ground plane as per ANSI C63.4: 1992 (see Test Facility for the dimensions of the ground plane used). When the EUT is a floor-standing equipment, it is placed on the ground plane which has a 3-12 mm non-conductive covering to insulate the EUT from the ground plane.
- 2) Support equipment, if needed, was placed as per ANSI C63.4: 1992.
- 3) All I/O cables were positioned to simulate typical actual usage as per ANSI C63.4: 1992.
- 4) The EUT received 120VAC/60Hz power source from the outlet socket under the turntable. All support equipment received 110VAC/60Hz power from another socket under the turntable, if any.
- 5) The antenna was placed at 10 meter away from the EUT as stated in ANSI C63.4: 1992. The antenna connected to the analyzer via a cable and at times a pre-amplifier would be used.
- 6) The analyzer quickly scanned from 30MHz to 2000MHz. The EUT test program was started. Emissions were scanned and measured rotating the EUT to 360 degrees and positioning the antenna 1 to 4 meters above the ground plane, in both the vertical and the horizontal polarization, to maximize the emission reading level.
- 7) The following test mode(s) were scanned during the preliminary test:

Mode(s): (Customer defined)

1. 1024 x 768 resolution with 533MHz CPU and 66MHz external clock + TV (AV in)
2. 800 x 600 resolution with 533MHz CPU and 66MHz external clock + TV (AV in)
3. 640 x 480 resolution with 533MHz CPU and 66MHz external clock + TV (AV in)

- 8) After the preliminary scan, we found the following test mode

Mode: 1.

Then, the EUT and cable configuration, antenna position, polarization and turntable position of the above highest emission level were recorded for reference of final testing.



MEASUREMENT PROCEDURE (FINAL RAIDATED EMISSION TEST)

- 1) EUT and support equipment were set up on the turntable as per step 8 of the preliminary test.
- 2) The Analyzer / Receiver scanned from 30MHz to 5000MHz. Emissions were scanned and measured rotating the EUT to 360 degrees, varying cable placement and positioning the antenna 1 to 4 meters above the ground plane, in both the vertical and the horizontal polarization, to maximize the emission reading level.
- 3) Recorded at least the six highest emissions. Emission frequency, amplitude, were recorded into a computer (The antenna position, polarization and turntable position were kept in raw data file) in which correction factors were used to calculate the emission level and compare reading to the applicable limit.
- 4) The test data of the worst case condition(s) was reported on the Summary Data page.

Data Sample:

Freq. (MHz)	Raw Data (dBuV/m)	Corr. Factor (dB)	Emiss. Level (dBuV/m)	Limits	Margin (dB)
xx.xx	14.0	11.2	26.2	40	-13.8

Freq.	= Emission frequency in MHz
Raw Data (dBuV/m)	= Uncorrected Analyzer / Receiver reading
Corr. Factor (dB)	= Correction factors of antenna factor and cable loss
Emiss. Level	= Raw reading converted to dBuV/m and CF added
Limit dBuV/m	= Limit stated in standard
Margin dB	= Reading in reference to limit



RADIATED EMISSION LIMIT

Frequency (MHz)	Distance (m)	Maximum Field Strength Limit (dBuV/m)		
		Q.P.	AVERAGE	PEAK
30-230	10	40	/	/
230-1000	10	47	/	/
Above 1000	3	/	60	80

**Note: “/” means the limit line isn’ t applicable.



SUMMARY DATA

(LINE CONDUCTED TEST)

Model Number: PCM-6890B(N)

Location: Site # 4

Tested by: Tony Tsai

Test Mode: Mode 1

Test Results: Passed

Temperature: 28°C

Humidity: 64%RH

(The chart below shows the highest readings taken from the final data)

FREQ MHz	Q.P. Raw dBuV	AVG Raw dBuV	Q.P. Limit dBuV	AVG Limit dBuV	Q.P. Margin dB	AVG Margin dB	NOTE
0.220	45.7	---	79.0	66.0	-33.3	---	L1
13.010	31.8	---	73.0	60.0	-41.2	---	L1
19.490	37.5	---	73.0	60.0	-35.5	----	L1
23.630	25.9	---	73.0	60.0	-47.1	---	L1
24.000	47.8	---	73.0	60.0	-25.2	---	L1
26.010	32.2	---	73.0	60.0	-40.8	---	L1
0.220	45.8	---	79.0	66.0	-33.2	---	L2
13.010	31.9	---	73.0	60.0	-41.1	---	L2
19.490	37.1	---	73.0	60.0	-35.9	---	L2
23.630	29.2	---	73.0	60.0	-43.8	---	L2
24.000	47.3	---	73.0	60.0	-25.7	---	L2
26.010	28.9	---	73.0	60.0	-44.1	---	L2

L1 = Line One (Hot side) / L2 = Line Two (Neutral side)

****NOTE:** “---” denotes the emission level was or more than 2dB below the Average limit, so no re-check anymore.



C&C Lab. Co. Shielded Room4
 CISPR 22 - Class A QP/AU Limit

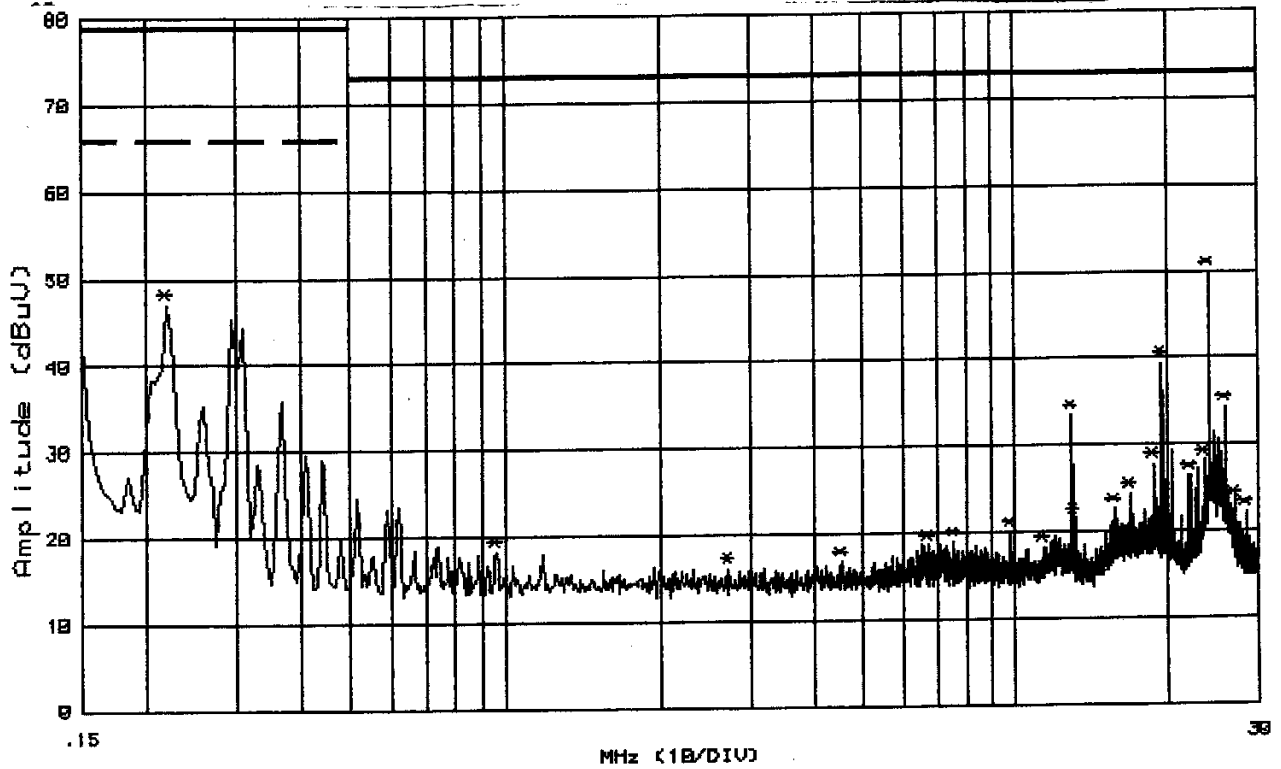

Customer:NA File#: 1507 Date :10 Jul 2000 17:16:34
 Model :PCM-6890B(N) Humd.:64 (%) Temp. :28 (C)
 Mode :FULL SYSTEM Port :L1 Tester:TONY TSAI
 Reading :Peak(R&S Receiver)
 Remark :1024*768

No.	Freq. (MHz)	Reading (dBuV)	I_Loss (dB)	Total (dBuV)	QP.Lmt (dBuV)	Margin (dB)	Warning Mark
1	.220	46.9	.1	47.0	79.0	-32.0	
2	.960	18.1	.2	18.3	73.0	-54.7	
3	2.720	15.9	.3	16.2	73.0	-56.8	
4	4.530	16.2	.5	16.7	73.0	-56.3	
5	6.720	18.1	.5	18.6	73.0	-54.4	
6	7.590	18.4	.5	18.9	73.0	-54.1	
7	9.830	19.5	.5	20.0	73.0	-53.0	
8	11.410	17.5	.8	18.3	73.0	-54.7	
9	13.010	32.6	.8	33.4	73.0	-39.6	
10	13.150	20.7	.8	21.5	73.0	-51.5	
11	15.810	21.6	1.0	22.6	73.0	-50.4	
12	16.920	23.3	1.0	24.3	73.0	-48.7	
13	18.740	26.8	1.0	27.8	73.0	-45.2	
14	19.490	38.4	1.0	39.4	73.0	-33.6	
15	22.100	25.3	1.1	26.4	73.0	-46.6	





SUMMARY DATA

(RADIATED EMISSION TEST)

Model Number: PCM-6890B(N)

Location: Site # 3

Tested by: Gimmy Tsai

Test Mode: Mode 1

Polar: Vertical -- 10m

Detector Function: Quasi-Peak

Test Results: Passed

Temperature: 28°C

Humidity: 68%RH

(The chart below shows the highest readings taken from the final data)

Freq. Data (MHz)	Raw Factor (dBuV/m)	Corr. Level (dB)	Emiss. (dBuV/m)	Limits	Margin (dB)
66.72	22.3	7.3	29.6	40.0	-10.4
120.21	20.0	14.5	34.5	40.0	-5.5
168.02	18.8	12.8	31.6	40.0	-8.4
200.63	17.3	11.6	28.9	40.0	-11.1
602.04	9.1	25.4	34.5	47.0	-12.5
869.09	13.3	27.6	40.9	47.0	-6.1





SUMMARY DATA

(RADIATED EMISSION TEST)

Model Number: PCM-6890B(N)

Location: Site # 3

Tested by: Gimmy Tsai

Test Mode: Mode 1

Polar: Horizontal -- 10m

Detector Function: Quasi-Peak

Test Results: Passed

Temperature: 28°C

Humidity: 68%RH

(The chart below shows the highest readings taken from the final data)

Freq. Data (MHz)	Raw Factor (dBuV/m)	Corr. Level (dB)	Emiss. (dBuV/m)	Limits	Margin (dB)
120.22	18.0	14.5	32.5	40.0	-7.5
132.07	15.0	14.4	29.4	40.0	-10.6
167.21	20.2	12.7	32.9	40.0	-7.1
200.65	18.0	11.7	29.7	40.0	-10.3
434.49	18.2	21.8	40.0	47.0	-7.0
501.67	13.3	23.2	36.5	47.0	-10.5



SUMMARY DATA

(RADIATED EMISSION TEST)

Model Number: PCM-6890B(N)

Location: 3 meter chamber

Tested by: Gimmy Tsai

Polar: Vertical ---3 m

Test Mode: Mode 1.

Detector Function: Pk / A.V.

Test Results: Passed

Temperature: 29°C

Humidity: 65RH

(The chart below shows the highest readings taken from the final data)

Freq. (MHz)	Raw Data (dBuV/m)	Corr. Factor (dB)	Emiss. Level (dBuV/m)	Limits (A.V))	Margin (dB)
1006.00	13.7	27.0	40.7	60	-19.3
--					
1143.00	14.0	27.4	41.4	60	-18.6
--					
1989.00	9.5	30.8	40.3	60	-19.7
--					
3651.00	8.7	36.3	45.0	60	-15.0
--					

****Note:** In case of peak reading complied with the A.V. limit at least 2dB margin, no further measurement with A.V. detector required.



APPENDIX 1

TEST FACILITY



TEST FACILITY

- Location:** No. 15, 14 Line, Chin Twu Chi, Lu Chu Hsiang, Taoyuan, Taiwan, R.O.C.
- Description:** There are three 3/10m open area test sites and three line conducted labs for final test, and one 3/10m open area test site for engineering lab.
The Open Area Test Sites and the Line Conducted labs are constructed and calibrated to meet the FCC requirements in documents ANSI C63.4: 1992 and CISPR 22/EN 55022 requirements.
- Site Filing:** A site description is on file with the Federal Communications Commission, 7435 Oakland Mills Road, Columbia, MD 21046.

Registration also was made with Voluntary Control Council for Interference (VCCI).
- Site Accreditation:** Accredited by NEMKO (Authorization #: ELA 124) for EMC & A2LA (Certificate #: 824.01) for Emission

Also accredited by BSMI for the product category of Information Technology Equipment.
- Instrument Tolerance:** All measuring equipment is in accord with ANSI C63.4 and CISPR 22 requirements that meet industry regulatory agency and accreditation agency requirement.
- Ground Plane:** Two conductive reference ground planes were used during the Line Conducted Emission, one in vertical and the other in horizontal. The dimensions of these ground planes are as below. The vertical ground plane was placed distancing 40 cm to the rear of the wooden test table on where the EUT and the support equipment were placed during test. The horizontal ground plane projected 50 cm beyond the footprint of the EUT system and distanced 80 cm to the wooden test table. For Radiated Emission Test, one horizontal conductive ground plane extended at least 1m beyond the periphery of the EUT and the largest measuring antenna, and covered the entire area between the EUT and the antenna. It has no holes or gaps having longitudinal dimensions larger than one-tenth of a wavelength at the highest frequency of measurement up to 1GHz.
- Site # 1 & # 3 Line Conducted Test Site:** Vertical ground plane (2.2m x 2.2m)
Horizontal ground plane (2.5m x 2.5m)
- Site # 4 Line Conducted Test Site:** At Shielding Room



APPENDIX 2

TEST EQUIPMENT LIST

TEST EQUIPMENT LIST

Instrumentation: The following list contains equipment used at C & C Laboratory, Co., Ltd. for testing. The equipment conforms to the CISPR 16-1 / ANSI C63.2-1988 Specifications for Electromagnetic Interference and Field Strength Instrumentation from 10kHz to 1.0 / 2.0 GHz.

Equipment used during the tests:

Open Area Test Site: # 1 ; # 3 ; # 4

Open Area Test Site # 1					
EQUIPMENT TYPE	MFR	MODEL NUMBER	SERIAL NUMBER	LAST CAL.	CAL. DUE
Spectrum Analyzer	ADVANTEST	R3261A	N/A	03/08/2000	03/07/2001
EMI Test Receiver	R&S	ESCS30	847793/012	11/06/1999	11/05/2000
PRE-AMP.	HP	8447F	2944A03748	10/22/1999	10/21/2000
Precision Dipole	R&S	HZ-12	846932/0004	07/13/1999	07/12/2000
Precision Dipole	R&S	HZ-13	846556/0008	07/13/1999	07/12/2000
Bilog Antenna	CHASE	CBL6112A	2309	02/13/2000	02/12/2001
Turn Table	EMCO	2081-1.21	N/A	N.C.R	N.C.R
Antenna Tower	EMCO	2075-2	9707-2604	N.C.R	N.C.R
Controller	EMCO	2090	N/A	N.C.R	N.C.R
RF Switch	ANRITSU	MP59B	N/A	N.C.R	N.C.R
Site NSA	C&C	N/A	N/A	11/10/1999	11/09/2000

Open Area Test Site # 3					
EQUIPMENT TYPE	MFR	MODEL NUMBER	SERIAL NUMBER	LAST CAL.	CAL. DUE
Spectrum Analyzer	ADVANTEST	R3261C	71720533	10/25/1999	10/24/2000
Pre-Amplifier	HP	8447D	2944A09173	02/01/2000	01/31/2001
EMI Test Receiver	R&S	ESVS20	838804/004	12/24/1999	12/23/2000
Precision Dipole	R&S	HZ-12	846932/0004	07/13/1999	07/12/2000
Precision Dipole	R&S	HZ-13	846556/0008	07/13/1999	07/12/2000
Bilog Antenna	CHASE	CBL6112A	2179	11/27/1999	11/26/2000
Turn Table	EMCO	2081-1.21	9709-1885	N.C.R	N.C.R
Antenna Tower	EMCO	2075-2	9707-2060	N.C.R	N.C.R
Controller	EMCO	2090	9709-1256	N.C.R	N.C.R
RF Switch	ANRITSU	MP59B	N/A	N.C.R	N.C.R
Site NSA	C&C	N/A	N/A	01/30/2000	01/30/2001



Open Area Test Site # 4					
EQUIPMENT TYPE	MFR	MODEL NUMBER	SERIAL NUMBER	LAST CAL.	CAL. DUE
Spectrum Analyzer	ADVANTEST	R3132	91700456	02/15/2000	02/14/2001
Pre-Amplifier	HP	8447F	2944A03748	10/22/1999	10/21/2000
EMI Test Receiver	R&S	ESVS10	846285/016	12/17/1999	12/16/2000
Precision Dipole	R&S	HZ-12	846932/0004	07/13/1999	07/12/2000
Precision Dipole	R&S	HZ-13	846556/0008	07/13/1999	07/12/2000
Bilog Antenna	CHASE	CBL 6112B	2462	01/13/2000	01/12/2001
Turn Table	Chance most	N/A	N/A	N.C.R	N.C.R
Antenna Tower	Chance most	N/A	N/A	N.C.R	N.C.R
Controller	Chance most	N/A	N/A	N.C.R	N.C.R
RF Switch	ANRITSU	MP59B	N/A	N.C.R	N.C.R
Site NSA	C&C Lab.	N/A	N/A	12/26/1999	12/25/2000

3 meter chamber					
EQUIPMENT TYPE	MFR	MODEL NUMBER	SERIAL NUMBER	LAST CAL.	CAL. DUE
Spectrum Analyzer	ADVANTEST	R3271A	85060321	01/12/2000	01/11/2001
Pre-Amplifier	HP	8449B	3008A00965	03/03/2000	03/02/2001
Horn Antenna	EMCO	3115	9602-4659	04/06/2000	04/05/2001
Coaxial Cable	ANOREW	LDF-2-50	79027	04/17/2000	04/16/2001
Turn Table	HD	DS 415	N/A	N.C.R	N.C.R
Antenna Tower	HD	MA 240	N/A	N.C.R	N.C.R
Controller	HD	HD 100	N/A	N.C.R	N.C.R



Conducted Emission Test Site: # 4

Conducted Emission Test Site # 4					
EQUIPMENT TYPE	* MFR	MODEL NUMBER	SERIAL NUMBER	LAST CAL.	CAL. DUE
EMI Test Receiver	R&S	ESHS10	843743/015	12/09/1999	12/08/2000
LISN	EMCO	3825/2	9106-1810	07/27/1999	07/26/2000
LISN	R&S	ESH2-Z5	843250/010	12/04/1999	12/03/2000

The calibrations of the measuring instruments, including any accessories that may effect such calibration, are checked frequently to assure their accuracy. Adjustments are made and correction factors applied in accordance with instructions contained in the manual for the measuring instrument.



APPENDIX 3

BLOCK DIAGRAM OF TEST SETUP

System Diagram of Connections between EUT and Simulators

EUT: CPU Board

Trade Name: N/A

Model Number: PCM-6890B(N)

Power Cord: Unshielded, 1.8m

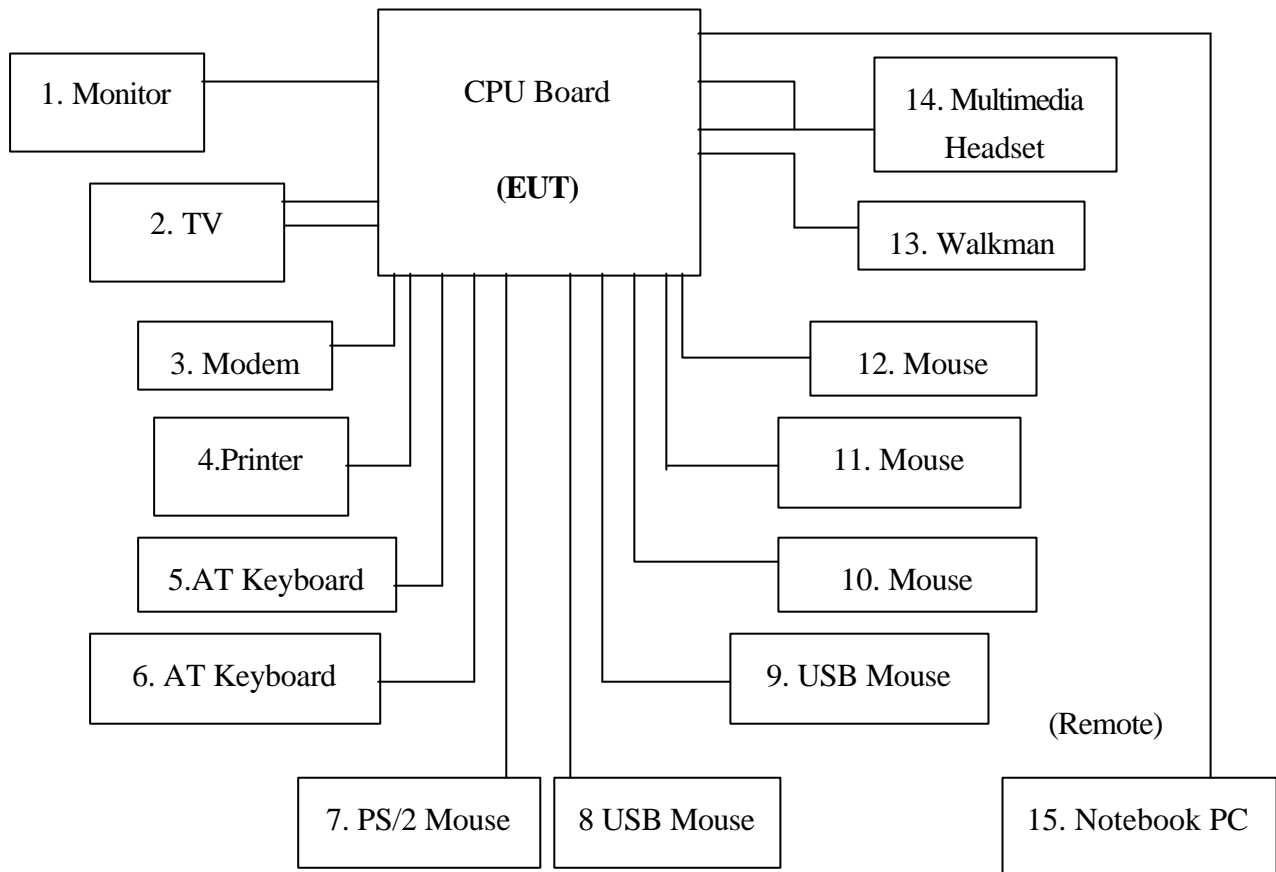



APPENDIX 4

PHOTOGRAPHS OF TEST SETUP

TEST SETUP OF LINE CONDUCTED EMISSION TEST



TEST SETUP OF RADIATED EMISSION TEST





APPENDIX 5

PHOTOGRAPHS OF EUT

Front View of PC



Rear View of PC



Open View of PC



Front View of PC (Model Number: PCM-6890B(N))

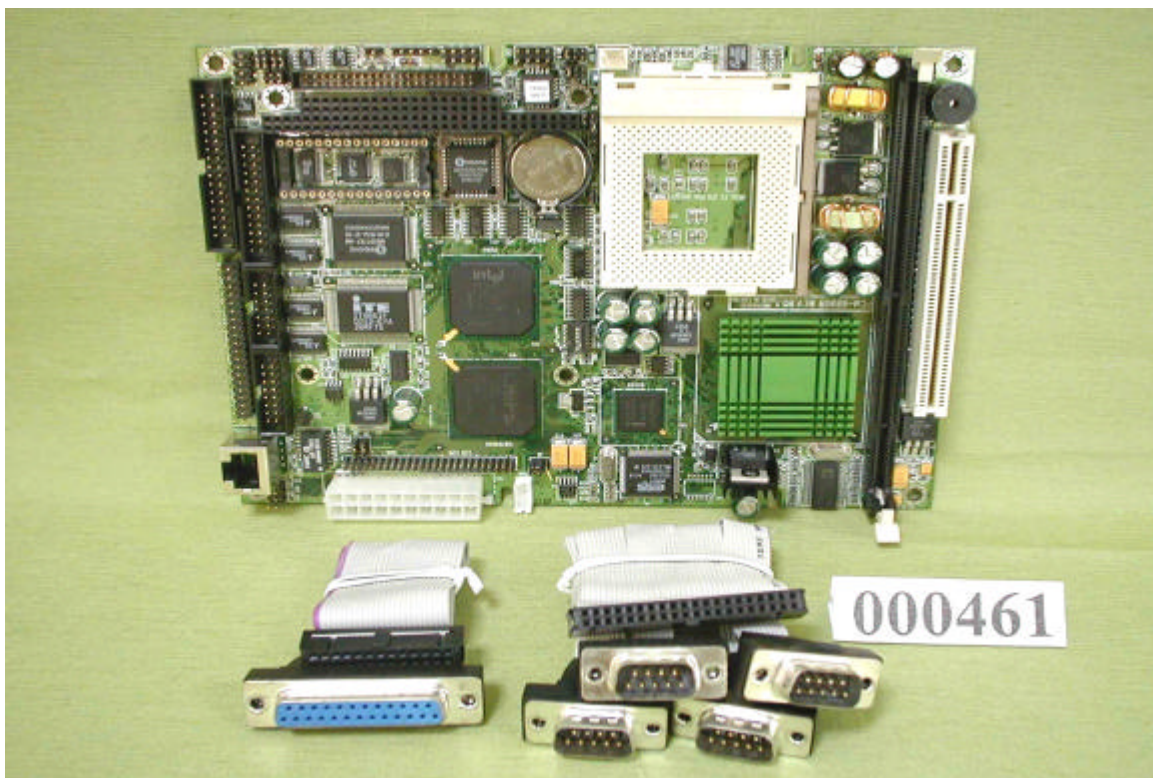

Rear View of PC (Model Number: PCM-6890B(N))

