

RTC-900R

(Non Packaging / Operating Mode)

Drop Test Report

Report NO: 13R030003



Issued by:	Rex Chang _____ Engineer	/	07/03/2013 _____ Date
Reviewed by:	Tom Lin _____ Sr. Manager	/	07/03/2013 _____ Date

Test item list

1. *Test item list* ----- 2
2. *Configuration of EUT* ----- 3
3. *Non-packaging / operation drop test* ----- 4

Testing Result

Num	Test item list	Result	Remark
1	Non-packaging / operating drop test	Pass	

Configuration of EUT

Test Product: RTC-900R		
Sample Configuration & Quantity Under Test:		
Num	Item	Spec
RTC-900R (with 3G Module)		
1.	TABLET PC	RTC-900R
	1. CPU	NVIDIA® Tegra™ 2 1.0GHz Dual-core CPU
	2. Memory	DDR2 1GB SDRAM
	3. LCD Monitor	10.1" WXGA (1280 x 800) TFT LCD with Projected Capacitive Touch screen panel
	4. Audio Codec	Wolfson.WM8903L
	5.GPS	BROADCOM BCM4751IFBG
	6.WiFi	AzureWave.AW-NH615
	7.3G Module	AnyDATA DTL718-W
	8.eMMC	Hynix.H26M52002CKR
	9.Android ver.	4.0.3
	10.Build number	IML74K US_epad-0.1.0.0-20130624 test-keys
2.	Battery	Lithium-Polymer high capacity battery (54WHr), 12 Hours Battery Life.
3.	AC Adapter	L.T.E. LTE24E-S2-2 AC Adapter

Drop Test

Test Date: 07-02-2013

Test Product: RTC-900R (with 3G Module)

Test Site: AAEON QE Dept.

Test Standard:

Refer to MIL-STD 810G Method 516.6 Procedure IV. Transit drop test.

Test Equipment:

Drop Tester

KING DESIGN Co. LTD.

Model: KD-128A

Serial Number: UU110099190

Test Condition:

1. Unit is Operating
2. Test Environment: Room Temperature.
3. Test Procedure: 122cm drop on the 2 inch plywood over concrete
4. Test Phase: Eight corners. Twelve edges. Six faces (total of 26 drops)
5. Test cycle: 1 cycle
6. Test Height: 122cm
7. Test Weight: 1.15Kg
8. Sample Quantity: 2 unit
9. Test Drawing:

Corners define

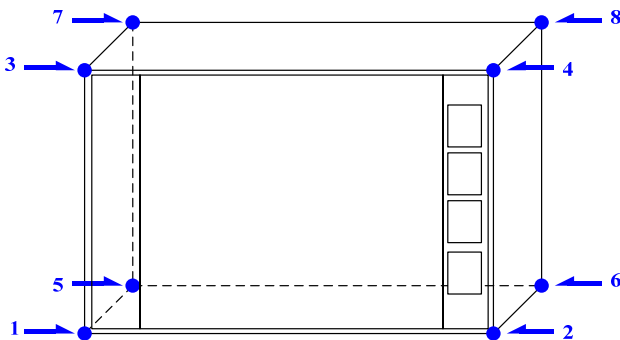

Edges define

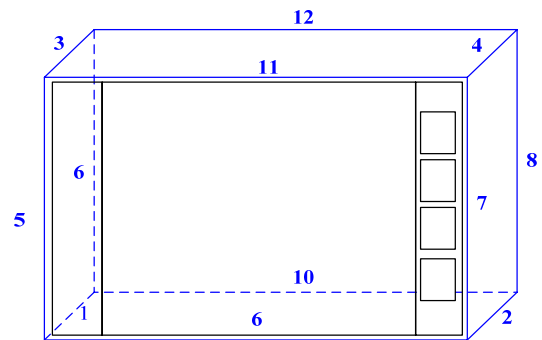

Faces define

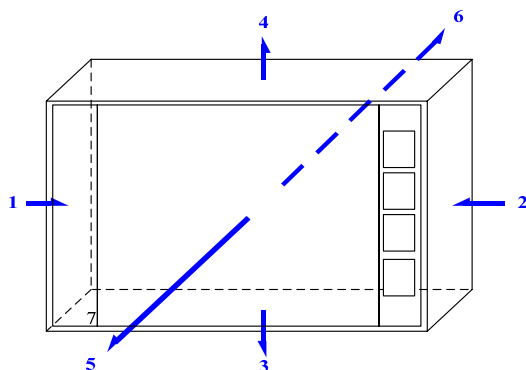

Drop Test

During Drop Test:

Test Item Sample No.	8 corners	12 edges	6 faces	Note
Sample 1	Pass	Pass	Pass	Note 1,2,3,4
Sample 2	Pass	Pass	Pass	Note 1,2,3,4

Note(*):

- The test system enter stand by mode (only turn off LCD) when the test unit dropped with edge of 7 and 8, the re-start unit work normally
- The test system shut down suddenly when the test unit dropped with edge 6, the re-start unit work normally
- The test system enter stand by mode (only turn off LCD) when the test unit dropped with faces 6, the re-start unit work normally
- The test system shut down suddenly when the test unit dropped with faces 5, the re-start unit work normally

Test Result: PASS

After Drop test					
Test Item / Testing practices		Sample No.	Sample 1	Sample 2	Note
3G	Networking / Download		Pass	Pass	
Wi-Fi	Networking / Download		Pass	Pass	
Camera lens	Take picture with front and back camera		Pass	Pass	
Gyroscope	Run Gyro_settlement_test Utility		Pass	Pass	
Vibration	Vibrate when press on specific symbol		Pass	Pass	
GPS	Run GPS Test Utility		Pass	Pass	
G-Sensor	Rotating the screen		Pass	Pass	
L-Sensor	Run LightSensor Utility		Pass	Pass	

Note(*):