

RTC-900B

(Non Packaging / Operating Mode)

Drop Test Report

Report NO: 14R030010



Issued by: Ben Sun / 12/18/2014
Engineer Date

Reviewed by: Vincent Chen / 12/18/2014
Sr. Manager Date

Test item list

1. *Test item list* ----- 2
2. *Configuration of EUT* ----- 3
3. *Non-packaging / operation drop test* ----- 4

Testing Result

Num	Test item list	Result	Remark
1	Non-packaging / operating drop test	Pass	

Configuration of EUT

Test Product: RTC-900B		
Sample Configuration & Quantity Under Test:		
Num	Item	Spec
RTC-900B		
01.	CPU:	Intel ® E3825 1.33GHz Dual core
02.	PCBA	A0.3
03.	BIOS	RTC-900B BIOS Rev1.0 x64 for Windows 8(11/25/2014)
04.	Memory	DDR3L-1600 4GB 204pin SO-DIMM Hynix
05.	mSATA	32GB mSATA SSD MLC
06.	3G	Quectel UC20
07.	WLAN + BT Module	AW-NB110H
08.	LCD	EJ101IA-01G
09.	Touch Panel	EDT EP1010MLD8
10.	Battery	AALIC As attached file
11.	AC Adapter	Adaptor LTE24E-S2-2D6
12.	Test Software	PassMark Burn In Test 7.0 Pro

Drop Test

Test Date: 12-17-2014

Test Product: RTC-900B

Test Site: AAEON QE Dept.

Test Standard:

Refer to MIL-STD 810G Method 516.6 Procedure IV. Transit drop test.

Test Equipment:

Drop Tester

KING DESIGN Co. LTD.

Model: KD-128A

Serial Number: UU110099190

Test Condition:

1. Unit is Operating
2. Test Environment: Room Temperature.
3. Test Procedure: 122cm drop on the 2 inch plywood over concrete
4. Test Phase: Eight corners. Twelve edges. Six faces (total of 26 drops)
5. Test cycle: 1 cycle
6. Test Height: 122cm
7. Test Weight: 1.24Kg
8. Sample Quantity: 1 unit
9. Test Drawing:

Corners define

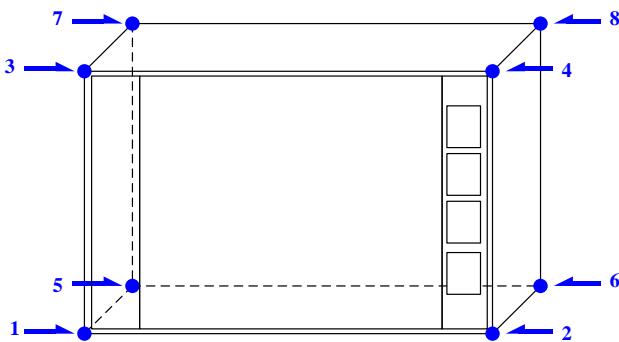

Edges define

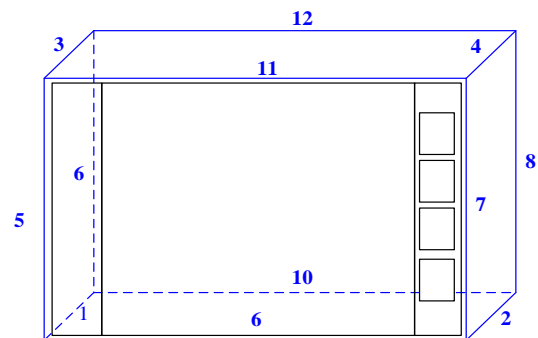

Faces define

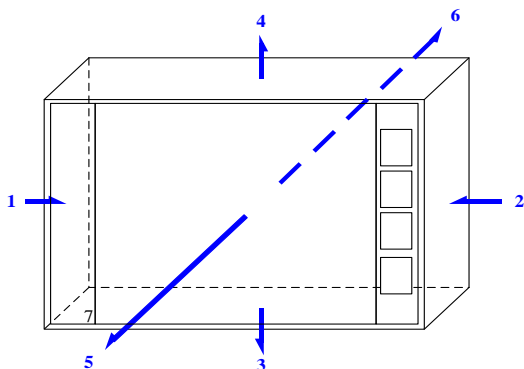

Drop Test

During Drop Test:

Test Item Sample No.	8 corners	12 edges	6 faces	Note
Sample 1	Pass	Pass	Pass	
Note(*):				

Test Result: PASS

No issues were found after the drop test.