

# **RTC-700M**

(Non Packaging / Operating Mode)

## **Drop Test Report**

**Report NO: 16R030002**

<b>Issued by:</b>	<b>Ben Sun</b> _____ Engineer	/	<b>05/06/2016</b> _____ Date
<b>Reviewed by:</b>	<b>KJ Wang</b> _____ Sr. Manager	/	<b>05/06/2016</b> _____ Date

# Test item list

---

1. *Test item list* ----- 2
2. *Configuration of EUT* ----- 3
3. *Non-packaging / operation drop test* ----- 4

## Testing Result

Num	Test item list	Result	Remark
1	Non-packaging / operating drop test	Pass	

# Configuration of EUT

Test Product: RTC-700M		
Sample Configuration & Quantity Under Test:		
Num	Item	Description
RTC-700M		
01.	<b>CPU:</b>	TI OMAP 4470
02.	<b>PCBA</b>	A0.3_0_1
03.	<b>BIOS</b>	none
04.	<b>Memory</b>	1GB LPDDR2 + 16GB eMMC
05.	<b>Storage</b>	16GB eMMC flash
06.	<b>3G</b>	QUECTEL UC20-G
07.	<b>WLAN + BT Module</b>	Jorjin WG7550 WIFI+BT_GPS module
08.	<b>Battery</b>	GETAC 2S1P 1530mAh x 2
09.	<b>AC Adapter</b>	FSP036-RBBN2
10.	<b>Test Software</b>	Android AP



# Drop Test

**Test Date:** 05-05-2016

**Test Product:** RTC-700M

**Test Site:** AAEON QE Dept.

**Test Standard:**

Refer to MIL-STD 810G Method 516.6 Procedure IV. Transit drop test.

**Test Equipment:**

Drop Tester

KING DESIGN Co. LTD.

Model: KD-128A

Serial Number: UU110099190

**Test Condition:**

1. Unit is Operating
2. Test Environment: Room Temperature.
3. Test Procedure: 122cm drop on the 2 inch plywood over concrete
4. Test Phase: Eight corners. Twelve edges. Six faces (total of 26 drops)
5. Test cycle: 1 cycle
6. Test Height: 122cm
7. Test Weight: 0.62Kg
8. Sample Quantity: 2 unit
9. Test Drawing:

**Corners define**

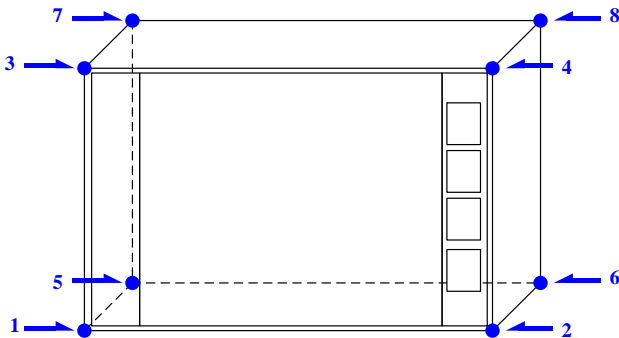

**Edges define**

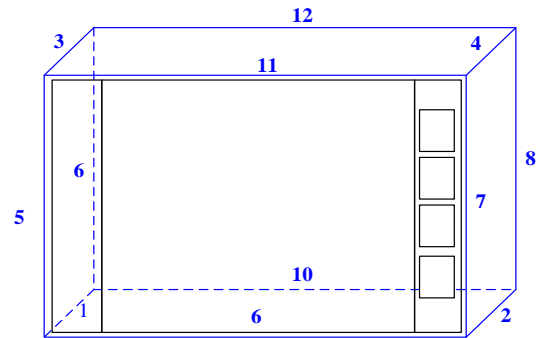

**Faces define**

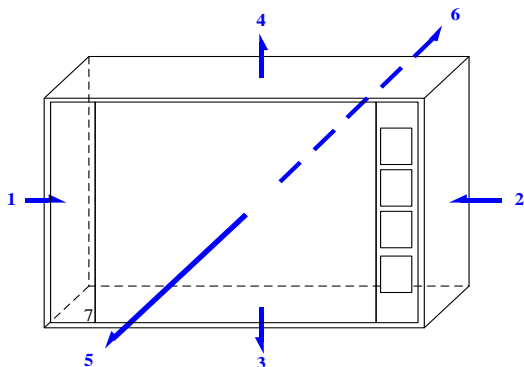

# Drop Test

---

## During Drop Test:

Test Item Sample No.	8 corners	12 edges	6 faces	Note
Sample 1	Pass	Pass	Pass	
Sample 2	Pass	Pass	Pass	
Note(*):				

## Test Result: PASS

No issues were found after the drop test.