

RTC-700C

(Non Packaging / Operating Mode)

Drop Test Report

Report NO: 14R030005



Issued by: Ben Sun / 10/17/2014
Engineer Date

Reviewed by: Tom Lin / 10/17/2014
Sr. Manager Date

Test item list

1. *Test item list* ----- 2
2. *Configuration of EUT* ----- 3
3. *Non-packaging / operation drop test* ----- 4

Testing Result

Num	Test item list	Result	Remark
1	Non-packaging / operating drop test	Pass	

Configuration of EUT

Test Product: RTC-700C		
Sample Configuration & Quantity Under Test:		
Num	Item	Spec
RTC-700C		
01.	CPU:	Intel® Atom™ Z2760 Processor / 1.8GHz
02.	PCBA	RTC-700C A0.3
03.	BIOS	BIOS (V0.4.7)
04.	Memory	DDRII 2GB Mobile RAM
05.	mSATA	eMMC 64GB/ SanDisk.SDIN7DP4-64G
	3G	Anydata DTL718-W-P
06.	WLAN + BT Module	AW-AH691
07.	Battery	JHT.JHT-795RTC70-A(J1067-1), 2S1P 3700mAh
08.	AC Adapter	LTE24E-S2-2C6 (Output: 12V / 2A)
09.	Test Software	Windows Embedded 8.1 / Run PassMark BurnIn Test 7.0 Pro

Drop Test

Test Date: 10-15-2014

Test Product: RTC-700C

Test Site: AAEON QE Dept.

Test Standard:

Refer to MIL-STD 810G Method 516.6 Procedure IV. Transit drop test.

Test Equipment:

Drop Tester

KING DESIGN Co. LTD.

Model: KD-128A

Serial Number: UU110099190

Test Condition:

1. Unit is Operating
2. Test Environment: Room Temperature.
3. Test Procedure: 122cm drop on the 2 inch plywood over concrete
4. Test Phase: Eight corners. Twelve edges. Six faces (total of 26 drops)
5. Test cycle: 1 cycle
6. Test Height: 122cm
7. Test Weight: 0.62Kg
8. Sample Quantity: 1 unit
9. Test Drawing:

Corners define

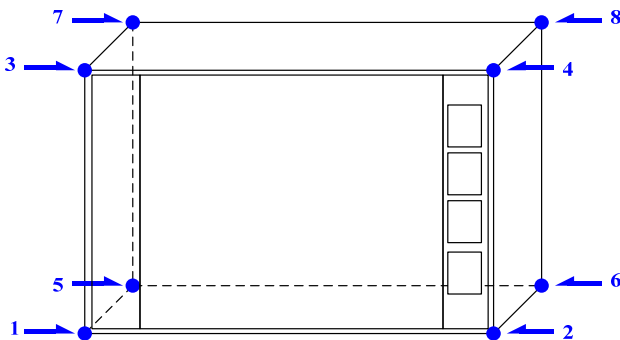

Edges define

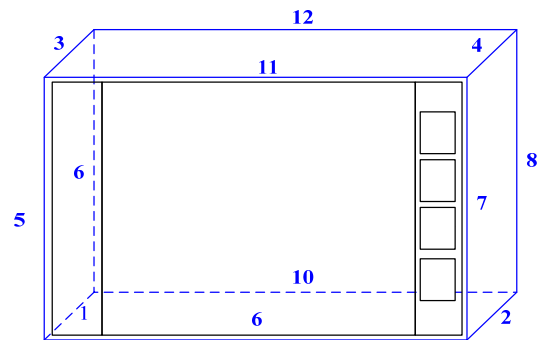

Faces define

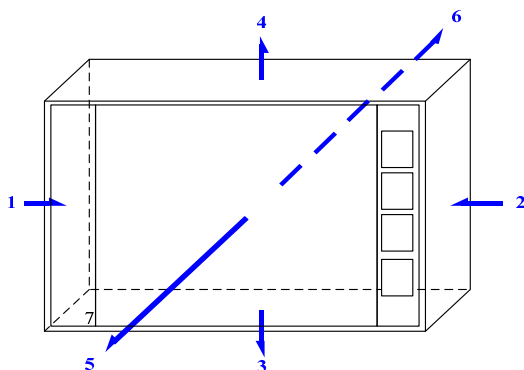

Drop Test

During Drop Test:

Test Item Sample No.	8 corners	12 edges	6 faces	Note
Sample 1	Pass	Pass	Pass	
Note(*):				

Test Result: PASS

No issues were found after the drop test.