

RTC-700B

(Non Packaging / Operating Mode)

Drop Test Report

Report NO: 16R030003

Issued by:	Ben Sun _____ Engineer	/	06/23/2016 _____ Date
Reviewed by:	KJ Wang _____ Sr. Manager	/	06/23/2016 _____ Date

Test item list

1. *Test item list* ----- 2
2. *Configuration of EUT* ----- 3
3. *Non-packaging / operation drop test* ----- 4

Testing Result

Num	Test item list	Result	Remark
1	Non-packaging / operating drop test	Pass	

Configuration of EUT

Test Product: RTC-700B		
Sample Configuration & Quantity Under Test:		
Num	Item	Description
RTC-700M		
01.	CPU:	Intel Atom x5-Z8350 Processor (2M Cache, up to 1.92 GHz)
02.	PCBA	Rev: A0.3_0_0
03.	BIOS	700B0511
04.	Memory	NANYA NT5CC256M16DP-DI (2GB DDRL-1600)
05.	Storage	Samsung KLMCG4JENB-B041 (eMMC 64GB)
06.	3G	QUECTEL UC20 Mini PCIe
07.	WLAN + BT Module	AMPAK WL334(802.11abgn+BT4.0)
08.	Battery	RTC600H, RTC600S (1530mAh x 2)
09.	AC Adapter	FSP036-RBBN2 (12VDC/3A/36W)
10.	Test Software	Windows 10 IOT Enterprise x64 Editoin



Drop Test

Test Date: 06-22-2016

Test Product: RTC-700B

Test Site: AAEON QE Dept.

Test Standard:

Refer to MIL-STD 810G Method 516.6 Procedure IV. Transit drop test.

Test Equipment:

Drop Tester

KING DESIGN Co. LTD.

Model: KD-128A

Serial Number: UU110099190

Test Condition:

1. Unit is Operating
2. Test Environment: Room Temperature.
3. Test Procedure: 122cm drop on the 2 inch plywood over concrete
4. Test Phase: Eight corners. Twelve edges. Six faces (total of 26 drops)
5. Test cycle: 1 cycle
6. Test Height: 122cm
7. Test Weight: 0.64Kg
8. Sample Quantity: 2 unit
9. Test Drawing:

Corners define

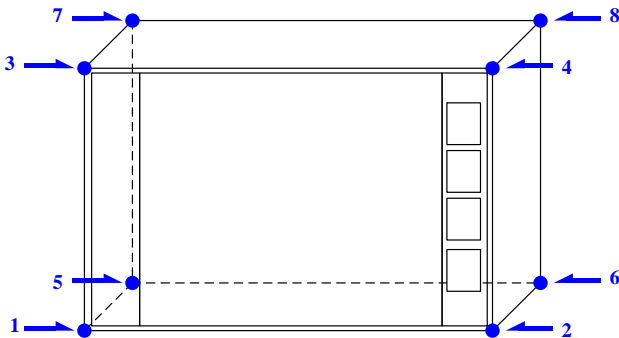

Edges define

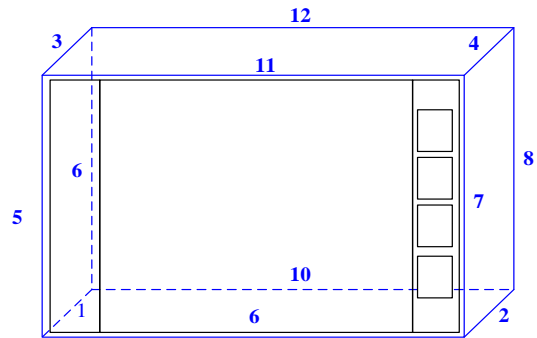

Faces define

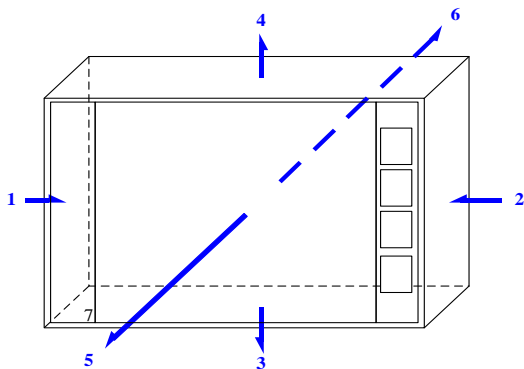

Drop Test

During Drop Test:

Test Item Sample No.	8 corners	12 edges	6 faces	Note
Sample 1	Pass	Pass	Pass	
Sample 2	Pass	Pass	Pass	
Note(*):				

Test Result: PASS

No issues were found after the drop test.