

RTC-1200SK

(Non Packaging / Operating Mode)

Drop Test Report

Report NO: 17R030001



Summary	<p><input checked="" type="checkbox"/> Pass</p> <p><input type="checkbox"/> Fail</p> <p>Note : There is/are ____ defect(s) not list in the report, please check it in the DTS Website.</p> <p><input type="checkbox"/> Pass with Deviation</p> <p>Comment: _____</p>
---------	---

Issue date

2017-03-21

QE Manager

KJ Wang

Test Engineer

Jerry Chen

Test item list

- 1. *Test item list* ----- 2
- 2. *Configuration of EUT* ----- 3
- 3. *Non-packaging / operation drop test* ----- 4

Testing Result

Num	Test item list	Result	Remark
1	Non-packaging / operating drop test	Pass	

Configuration of EUT

Test Product: RTC-1200SK		
Sample Configuration & Quantity Under Test:		
Num	Item	Spec
RTC-1200SK		
01.	CPU:	Sample#1: Intel Skylake Celeron 3955U 2.0 GHz & Sample#2: Intel Skylake i3-6100U 2.3 GHz
02.	PCBA	RTC-1200SK REV. A0.3
03.	BIOS	BIOS Rev0.52 / EC Rev 0.03.45
04.	Memory	Transcend DD3L SODIMM 4G 1 Rx 8 1600
05.	3G Module	QUECTEL UC20GA
06.	WLAN + BT Module	Ampak AP12356
07.	LCD+ Touch Panel	LITEMAX OLP1167-ITN-A01(1920*1080)
08.	GPS	u-blox NEO-M8Q
09.	Battery	ETICA BP16-001570 , (4S1P , 14.8V 2.27Ah)
10.	AC Adapter	FSP. FSP065-REBN2(Output 19V 3.42A)
11.	AC Power Input	100~240V / 1.5A 50~60 Hz
12.	Test Software	Windows 10 Enterprise 2016 LTSB/ Run PassMark BurnIn Test 7.1 Pro
13	SSD	Transcend TS64GMTS800-AA 64G SATA A3 2280
14	Front Camera	Gotek NCO-062FR-XA05
15	Rear Camera	Gotek NCO-045AS-RL03

Drop Test

Test Date: 03-17-2017

Test Product: RTC-1200SK

Test Site: AAEON QE Dept.

Test Standard:

Reference MIL-STD 810G Method 516.6 Procedure IV. Transit drop test.

Test Equipment:

Drop Tester

KING DESIGN Co. LTD.

Model: KD-128A

Serial Number: UU110099190

Test Condition:

1. Unit is Operating
2. Test Environment: Room Temperature.
3. Test Procedure: 122cm drop on the 2 inches plywood over concrete
4. Test Phase: 8 corners. 12 edges. 6 faces (total of 26 drops)
5. Test cycle: 1 cycle
6. Test High: 122cm
7. Test Weight: 1.73Kg
8. Sample Quantity: 2 unit
9. Test Drawing:

Corners define

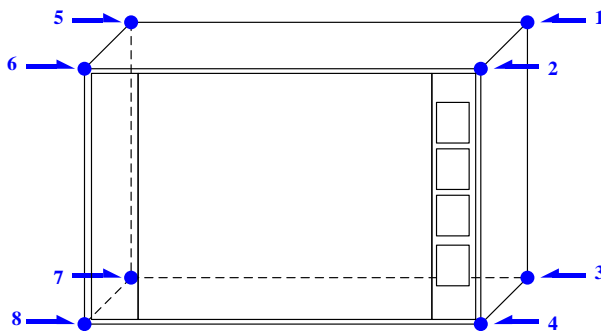

Edges define

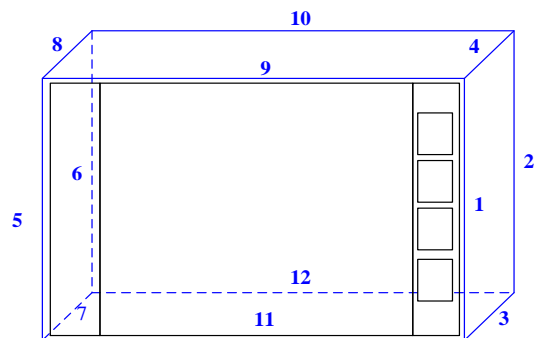

Faces define

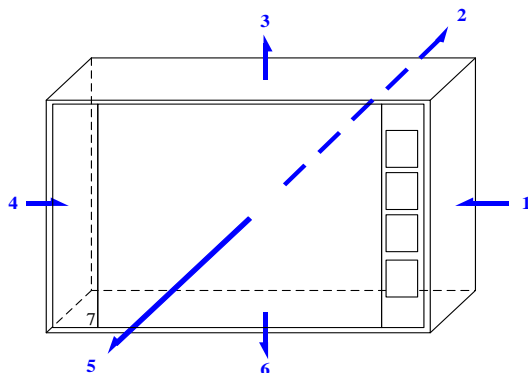

Drop Test

Test Result:

During Test:

Test Item Sample No.	8 corners	12 edges	6 faces	Note
Sample 1	Pass	Pass	Pass	Note 1

Note(*):

1. The test system is shutdown when the test unit dropped with face 5, and then re-start the unit can be work normally.

Test Item Sample No.	8 corners	12 edges	6 faces	Note
Sample 2	Pass	Pass	Pass	Note 1, 2

Note(*):

1. The one battery cover jump out when the test unit dropped with corner 6, the unit works normally.
2. The test system reboot when the test unit dropped with face 5, the unit can be work normally.

After test:

1. .Observation with our frame is no any defect. There is no any loose with antenna and part disconnect.
2. Turn on the power and check the 3G, camera, video microphone, WiFi, light-sensor, Bluetooth, HDMI, GPS, Micro SD storage, audio, screen rotation, USB function work correct under Windows.