

RTC-700A

(Non Packaging / Operating Mode)

Drop Test Report

Report NO: 15R030001



Summary	<p><input checked="" type="checkbox"/> Pass</p> <p><input type="checkbox"/> Fail</p> <p>Note : There is/are ____ defect(s) not list in the report, please check it in the DTS Website.</p> <p><input type="checkbox"/> Pass with Deviation</p> <p>Comment: _____</p>
---------	---

Issue date

2015-07-09

Approval

KJ Wang

Test Engineer

Rex Chang

Test item list

- 1. *Test item list* ----- 2
- 2. *Configuration of EUT* ----- 3
- 3. *Non-packaging / operation drop test* ----- 4

Testing Result

Num	Test item list	Result	Remark
1	Non-packaging / operating drop test	Pass	

Configuration of EUT

Test Product: RTC-700A		
Sample Configuration & Quantity Under Test:		
Num	Item	Spec
RTC-700A ((with Bar Code Scanner and External GPS))		
1.	TABLET PC	RTC-700A
	1. CPU	NVIDIA® Tegra™ 2 1.0GHz Dual-core CPU
	2. Memory	DDR2 1GB SDRAM
	3. LCD Monitor	7" WXGA (1280 x 800) TFT LCD with Projected Capacitive Touch screen panel
	4. Audio Codec	Wolfson.WM8903L
	5.GPS	BROADCOM BCM4751IFBG
	6.WiFi	AzureWave.AW-NH615
	7.3G Module	Anydata 16671872
	8.eMMC	Hynix.H26M52103FMR
	9.Bar Code Scanner	OPTICON MDI-3100
	10.External GPS	Max-M8C-000
	11.Android ver.	4.0.3
	12.Build number	IML74K.RTC700A-0.1.0.0-20141219
2.	Battery	Lithium-Polymer high capacity battery (31WHr), 6 Hours Battery Life.
3.	AC Adapter	L.T.E. LTE24E-S2-2 AC Adapter

Drop Test

Test Date: 07-08-2015

Test Product: RTC-700A A1.2

Test Site: AAEON QE Dept.

Test Standard:

Reference MIL-STD 810G Method 516.6 Procedure IV. Transit drop test.

Test Equipment:

Drop Tester

KING DESIGN Co. LTD.

Model: KD-128A

Serial Number: UU110099190

Test Condition:

1. Unit is Operating
2. Test Environment: Room Temperature.
3. Test Procedure: 122cm drop on the 2 inches plywood over concrete
4. Test Phase: 8 corners. 12 edges. 6 faces (total of 26 drops)
5. Test cycle: 1 cycle
6. Test High: 122cm
7. Test Weight: 0.62Kg
8. Sample Quantity: 3 unit
9. Test Drawing:

Corners define

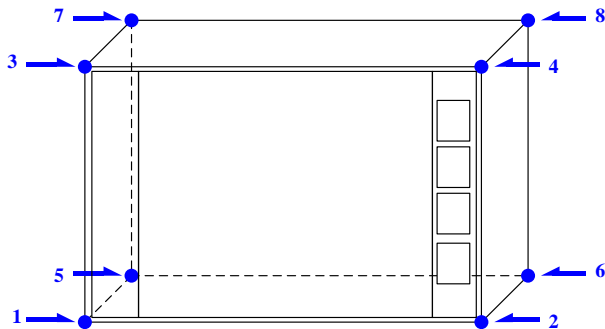

Edges define

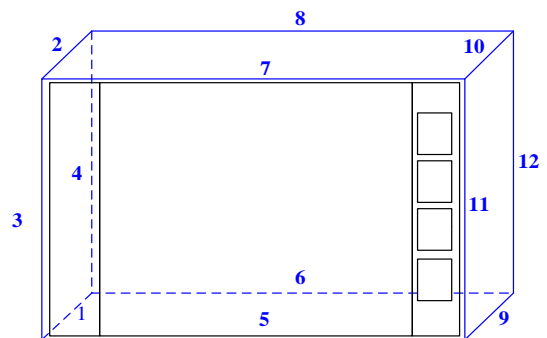

Faces define

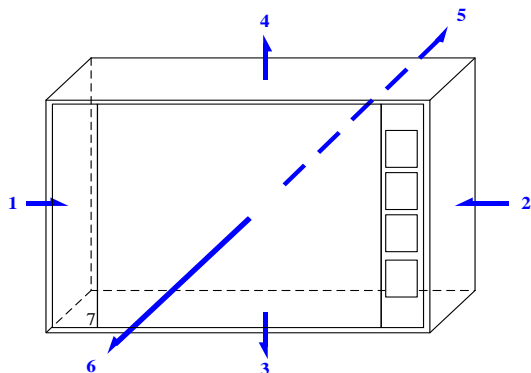

Drop Test

Test Result:

During Test:

Test Item Sample No.	8 corners		Note
Sample 1	Pass		—
Note(*):			
Test Item Sample No.	8 edges (1~8)		Note
Sample 2	Pass		Note 1
Note(*):			
1. The test system enter standby mode (only turn off LCD) when the test unit dropped with edge 8, the re-start unit work normally			
Test Item Sample No.	4 edges (9~12)	6 Faces	Note
Sample 3	Pass	Pass	Note 1, 2
Note(*):			
1. The test system enter standby mode (only turn off LCD) when the test unit dropped with face 4, the re-start unit work normally			
2. The 3G card at face 3 drop test (with docking connection face down) is jumper out. when put 3G card back to the function is working correctly.			

After test:

1. Observation with our frame is no any defect. There is no any loose with antenna and part disconnect.
2. Turn on the power and check the 3G, camera, video microphone, WiFi, light-sensor, Bluetooth, HDMI, Bar code scanner, GPS, Micro SD storage, screen rotation, USB function work correct under Android.