

KING DESIGN INDUSTRIAL CO., LTD.

5F, NO. 3, Lane 270, Pei Shen Road Sec. 3,

Shen Keng Dist., New Taipei City, 222, Taiwan, R.O.C

TEL: 886-2-2662-5100 FAX: 886-2-2662-3094

**RELIABILITY TEST LABORATORY**<http://www.kdi.tw><http://www.vibration.com.tw>E-mail: [service@kdi.tw](mailto:service@kdi.tw)**TESTING / INSPECTION REPORT**

REPORT NO : DT-130110-1

COMPANY : AAEON Technology Inc.

ADDRESS : 5F, No.135, Lane 235, Pao Chiao Rd.

Hsin-Tien City, Taipei, Taiwan, R. O. C.

TEL : 886-2-8919-1234

FAX : 886-2-8919-1049

SPECIMEN : DSS-CV21(With 2.5" HDD)

DATE OF RECEIVED : 2013/01/02

DATE OF TESTED : 2013/01/02

TEST / INSPECTION ITEMS : Drop Test

## REMARKS :

- The laboratory is accredited by ISO/IEC 17025 General Requirements for the Competence of Calibration and Testing Laboratory.
- The results only apply to the device under test.
- This report is 17 pages, and no part of it may be abstracted or reproduced.

Test Engineer :



Approval Signatory :



Laboratory Head :

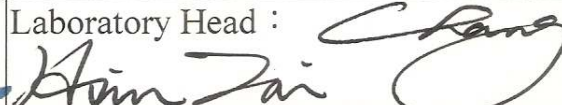

**KING DESIGN INDUSTRIAL CO., LTD.**

5F,NO. 3, Lane 270, Pei Shen Road Sec. 3,

Shen Keng Dist., New Taipei City, 222, Taiwan, R.O.C

TEL: 886-2-2662-5100 FAX: 886-2-2662-3094

**RELIABILITY TEST LABORATORY**<http://www.kdi.tw><http://www.vibration.com.tw>

E-mail:service@kdi.tw

## TESTING / INSPECTION REPORT

### TESTING EQUIPMENT :

- 1.Drop Testing System : KING DESIGN KD-128A, S/N : 02370206-22  
2.Controller : Lansmont TP-3, S/N:0506-046  
3.Measuring Accelerometer : DYTRAN3053B, S/N:1242

### TEST ENVIRONMENT :

- Temperature : 24.2°C (25±10°C)  
Relative Humidity : 62%RH (50±25% RH)

### SPECIMEN :

- Model : DSS-CV21(With 2.5" HDD)  
Quantity : 1 carton

### TEST SPECIFICATION :

- For ISTA 1A  
Weight : 3.12 kg  
Drop Height : 76 cm  
Drop Onto : 1 corner, 3 edges & 6 faces

### TEST RESULT :

Describe	PASS	FAIL	Non-Judgment
Function judgment	√	---	---
Appearance check	√	---	---

## TESTING / INSPECTION REPORT

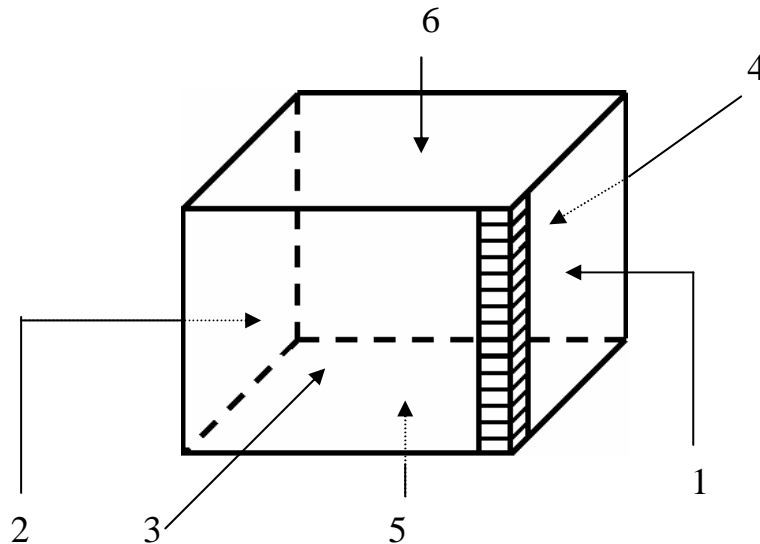



1	The 1-3-5 Corner	Corner
2	The shortest edge radiating from that corner	Edge
3	The next longest edge radiating from that corner	Edge
4	The longest edge radiating from that corner	Edge
5	Flat on one of the smallest faces	Flat
6	Flat on one of the opposite small faces	Flat
7	Flat on one of the medium faces	Flat
8	Flat on one of the opposite medium faces	Flat
9	Flat on one of the largest faces	Flat
10	Flat on one of the opposite largest faces	Flat

**KING DESIGN INDUSTRIAL CO., LTD.**  
 5F,NO. 3, Lane 270, Pei Shen Road Sec. 3,  
 Shen Keng Dist., New Taipei City, 222, Taiwan, R.O.C  
 TEL: 886-2-2662-5100 FAX: 886-2-2662-3094

**RELIABILITY TEST LABORATORY**  
<http://www.kdi.tw>  
<http://www.vibration.com.tw>  
 E-mail:service@kdi.tw

## TESTING / INSPECTION REPORT

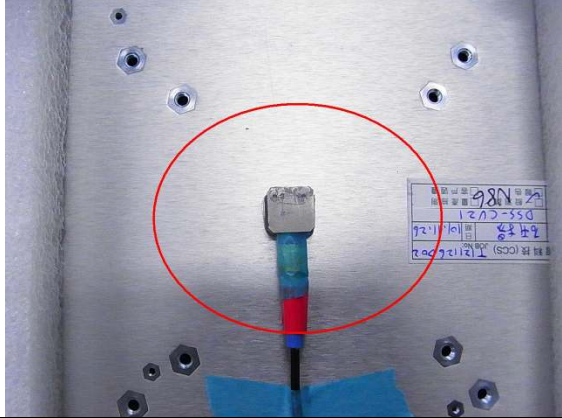
Testing photos	
<b>Before test-1</b>	<b>Before test-2</b>
	
<b>Before test-3</b>	<b>Before test-4</b>
	



**TESTING / INSPECTION REPORT**

**Testing photos**

**Corner**



**Edge-1**



**Edge-2**

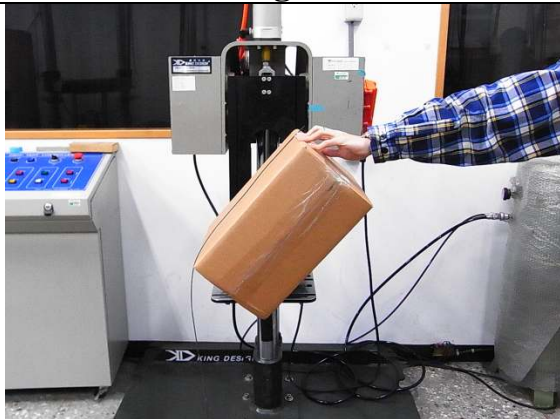

**Edge-3**

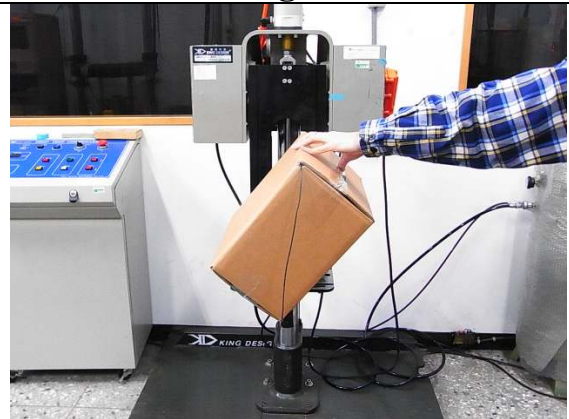

## TESTING / INSPECTION REPORT

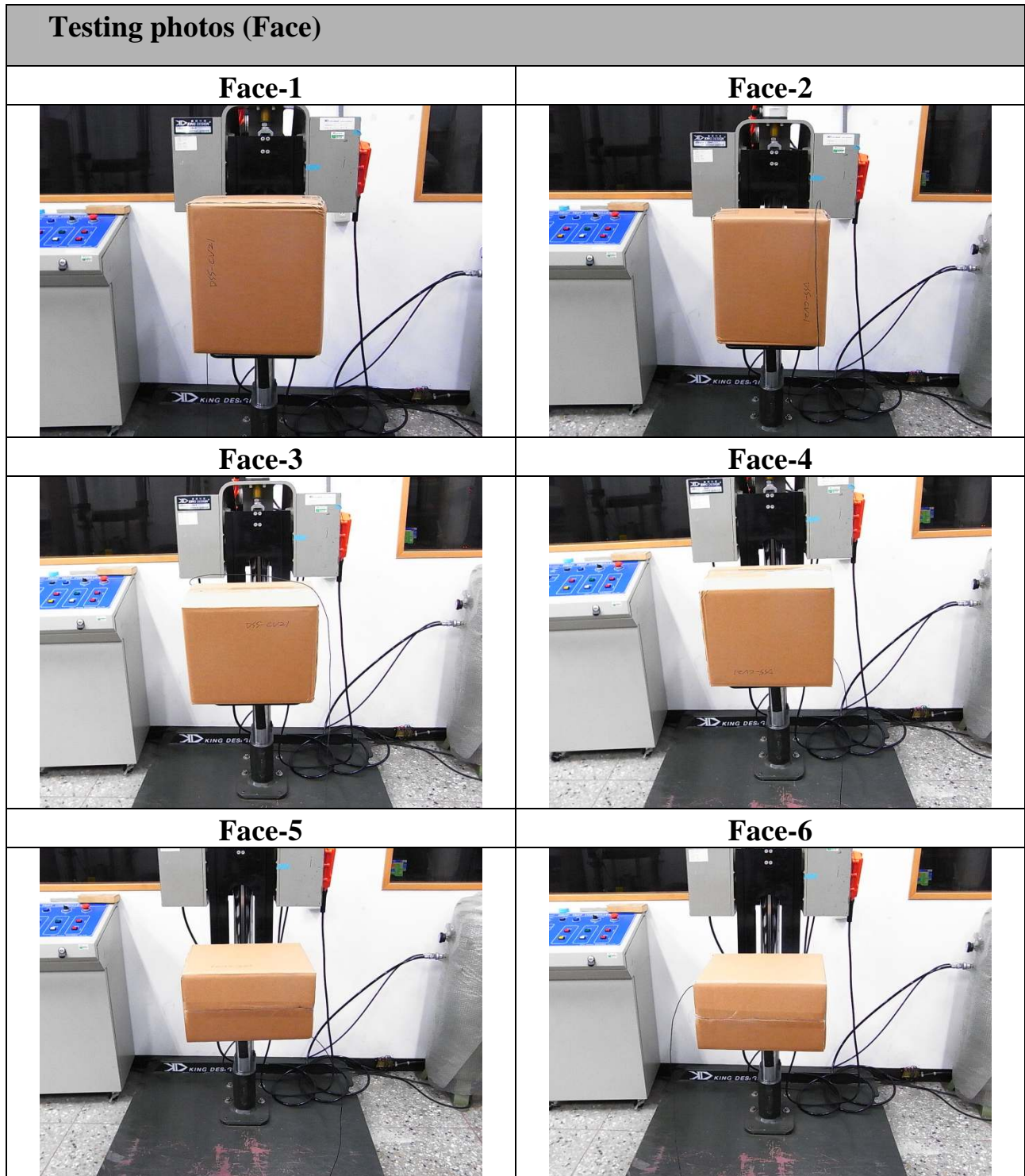

**KING DESIGN INDUSTRIAL CO., LTD.**

5F,NO. 3, Lane 270, Pei Shen Road Sec. 3,

Shen Keng Dist., New Taipei City, 222, Taiwan, R.O.C

TEL: 886-2-2662-5100 FAX: 886-2-2662-3094

**RELIABILITY TEST LABORATORY**

<http://www.kdi.tw>

<http://www.vibration.com.tw>

E-mail:service@kdi.tw

## TESTING / INSPECTION REPORT

### Testing photos

#### After test



**KING DESIGN INDUSTRIAL CO., LTD.**

5F, NO. 3, Lane 270, Pei Shen Road Sec. 3,

Shen Keng Dist., New Taipei City, 222, Taiwan, R.O.C

TEL: 886-2-2662-5100 FAX: 886-2-2662-3094

**RELIABILITY TEST LABORATORY**
<http://www.kdi.tw>
<http://www.vibration.com.tw>

E-mail: service@kdi.tw

## Corner

### Acceleration vs Time

	Channel Description:	G's	msec	In/S	Filter Hz	Max G's	Min G's
Ch1	Ch1	24.14	22.30	123.53	220.00	24.14	-4.29
Ch2	Ch2	23.34	20.30	120.07	220.00	23.34	-3.24
Ch3	Ch3	14.49	9.30	35.37	220.00	14.49	-5.22

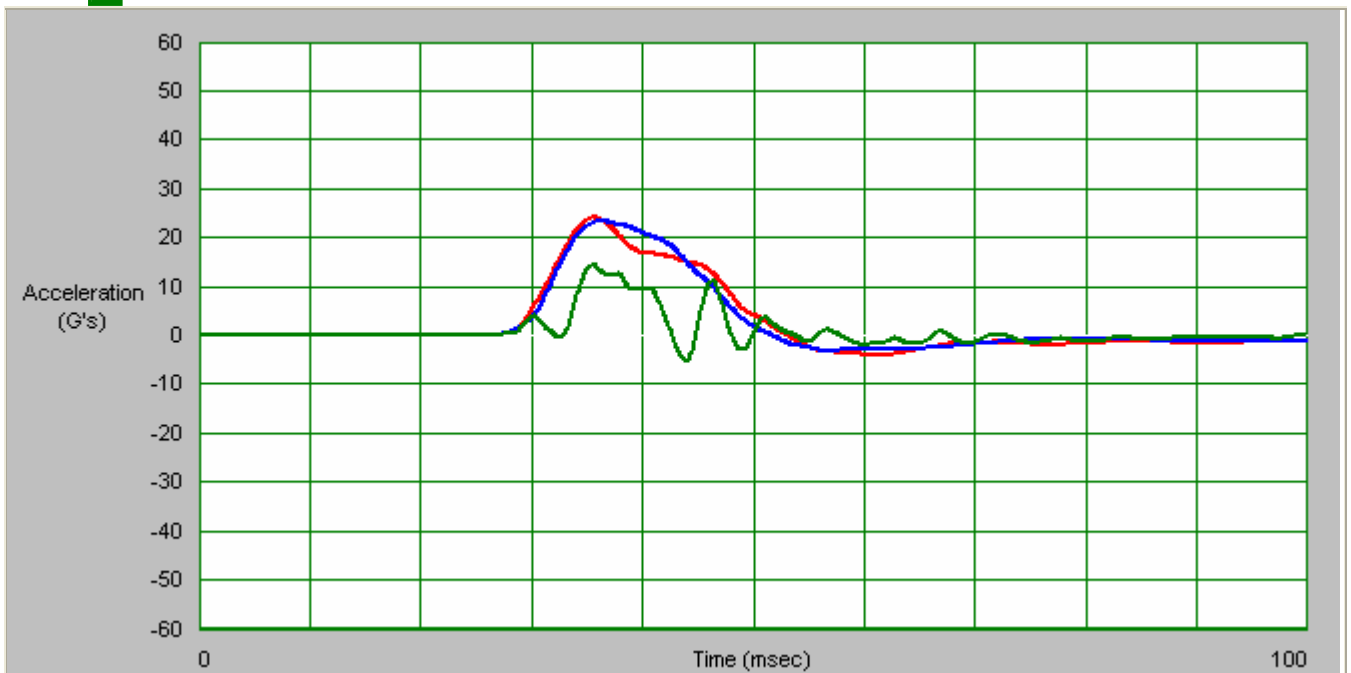



**KING DESIGN INDUSTRIAL CO., LTD.**

5F,NO. 3, Lane 270, Pei Shen Road Sec. 3,

Shen Keng Dist., New Taipei City, 222, Taiwan, R.O.C

TEL: 886-2-2662-5100 FAX: 886-2-2662-3094

**RELIABILITY TEST LABORATORY**
<http://www.kdi.tw>
<http://www.vibration.com.tw>

E-mail:service@kdi.tw

**Edge-1**
**Acceleration vs Time**

	Channel Description:	G's	msec	In/S	Filter Hz	Max G's	Min G's
Ch1	Ch1	28.18	19.20	127.96	220.00	28.18	-4.77
Ch2	Ch2	26.33	19.10	127.82	220.00	26.33	-4.77
Ch3	Ch3	18.97	9.50	45.09	220.00	18.97	-5.70

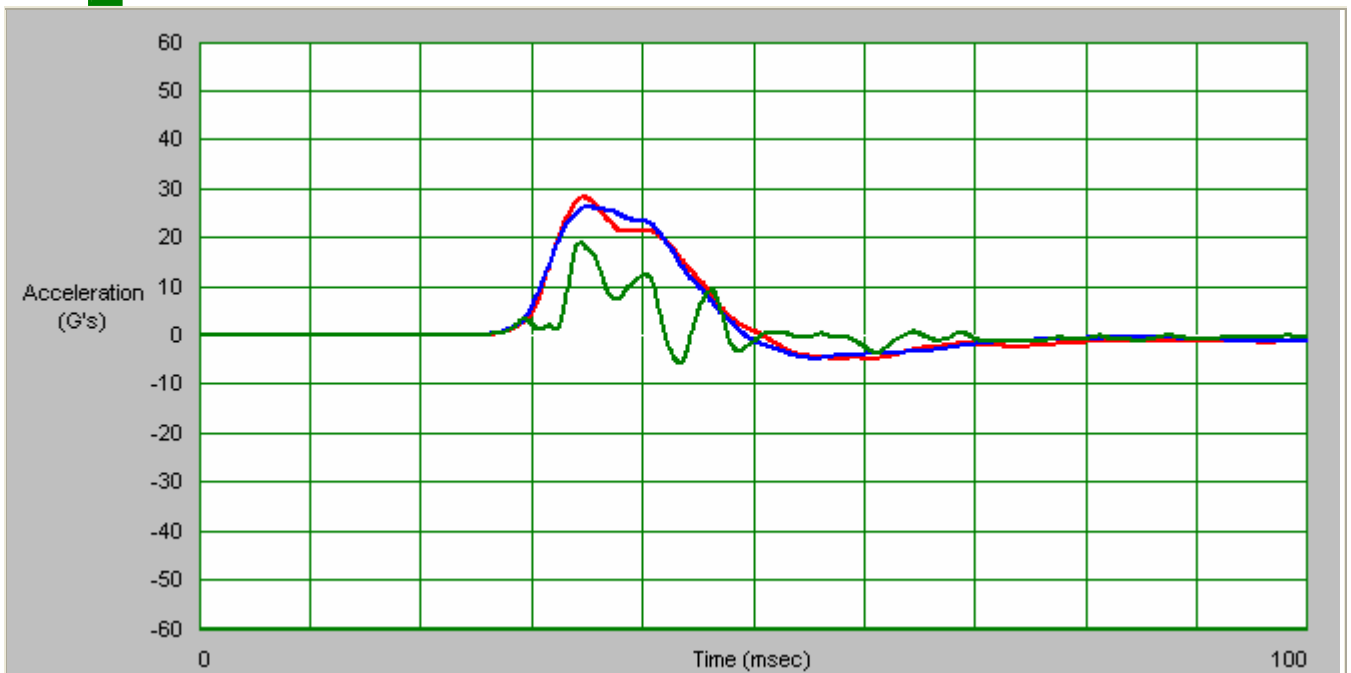

**KING DESIGN INDUSTRIAL CO., LTD.**

5F,NO. 3, Lane 270, Pei Shen Road Sec. 3,

Shen Keng Dist., New Taipei City, 222, Taiwan, R.O.C

TEL: 886-2-2662-5100 FAX: 886-2-2662-3094

**RELIABILITY TEST LABORATORY**
<http://www.kdi.tw>
<http://www.vibration.com.tw>

E-mail:service@kdi.tw

**Edge-2**
**Acceleration vs Time**

	Channel Description:	G's	msec	In/S	Filter Hz	Max G's	Min G's
Ch1	Ch1	8.64	8.70	15.93	220.00	8.64	-2.65
Ch2	Ch2	30.57	21.50	176.06	220.00	30.57	-3.93
Ch3	Ch3	23.05	9.80	56.63	220.00	23.05	-7.64

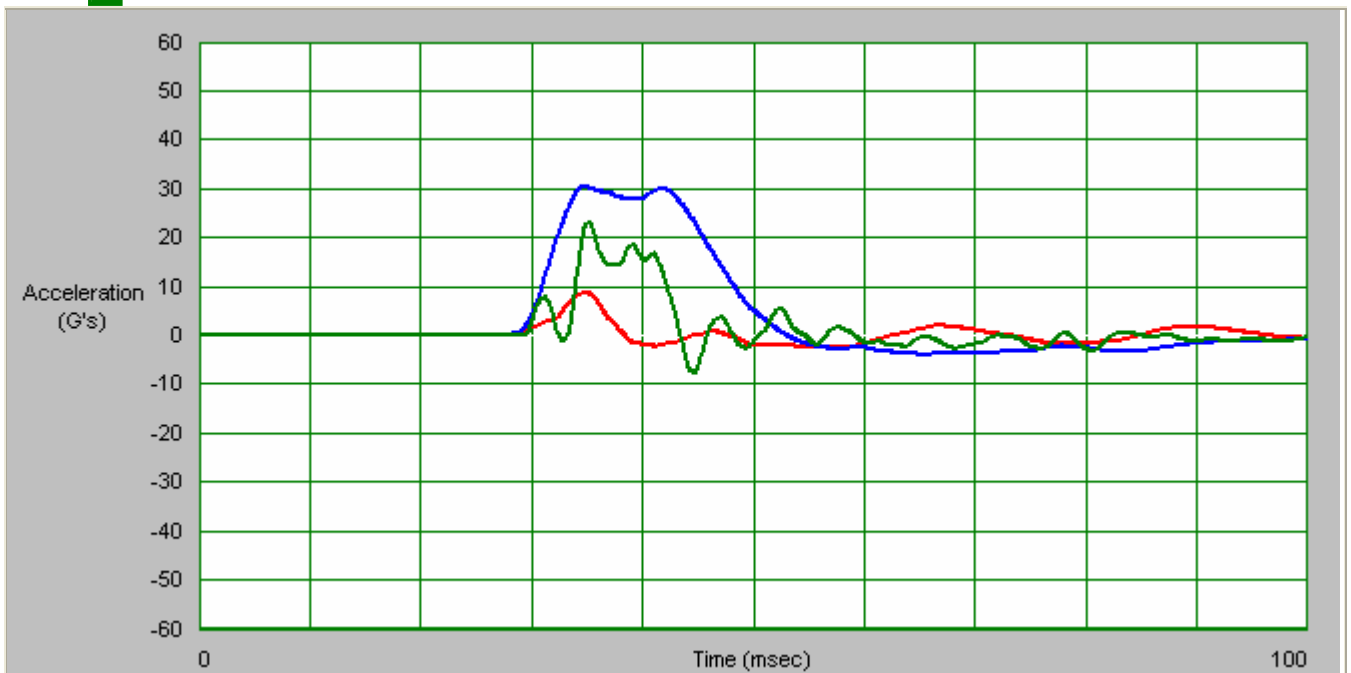

**KING DESIGN INDUSTRIAL CO., LTD.**

5F,NO. 3, Lane 270, Pei Shen Road Sec. 3,

Shen Keng Dist., New Taipei City, 222, Taiwan, R.O.C

TEL: 886-2-2662-5100 FAX: 886-2-2662-3094

**RELIABILITY TEST LABORATORY**
<http://www.kdi.tw>
<http://www.vibration.com.tw>

E-mail:service@kdi.tw

### Edge-3

#### Acceleration vs Time

	Channel Description:	G's	msec	In/S	Filter Hz	Max G's	Min G's
Ch1	Ch1	30.67	21.10	159.94	220.00	30.67	-4.82
Ch2	Ch2	15.95	9.20	35.99	220.00	15.95	-5.74
Ch3	Ch3	26.24	14.30	71.59	220.00	26.24	-3.40

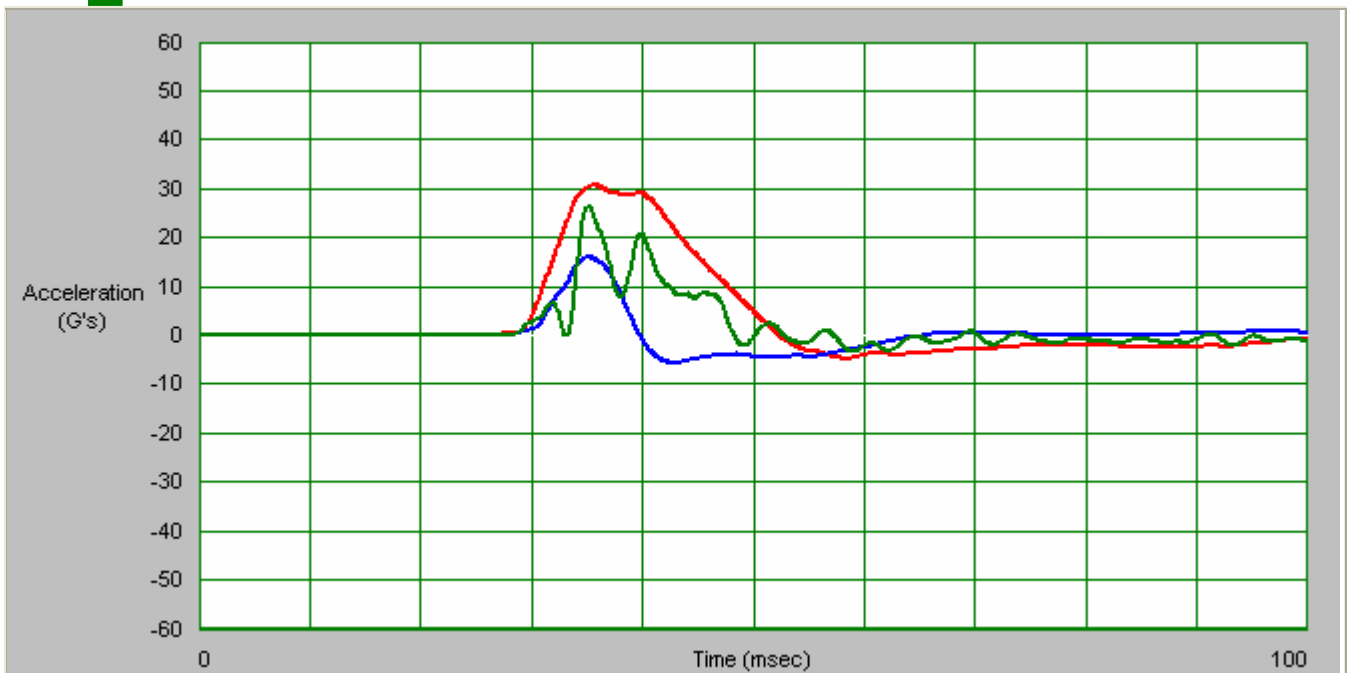

**KING DESIGN INDUSTRIAL CO., LTD.**  
 5F,NO. 3, Lane 270, Pei Shen Road Sec. 3,  
 Shen Keng Dist., New Taipei City, 222, Taiwan, R.O.C  
 TEL: 886-2-2662-5100 FAX: 886-2-2662-3094

**RELIABILITY TEST LABORATORY**  
<http://www.kdi.tw>  
<http://www.vibration.com.tw>  
 E-mail:service@kdi.tw

### Face-1

## Acceleration vs Time

	Channel Description:	G's	msec	In/S	Filter Hz	Max G's	Min G's
Ch1	Ch1	13.19	21.10	69.14	220.00	13.19	-4.58
Ch2	Ch2	29.44	25.40	180.23	220.00	29.44	-3.42
Ch3	Ch3	10.82	14.10	29.48	220.00	10.82	-1.77

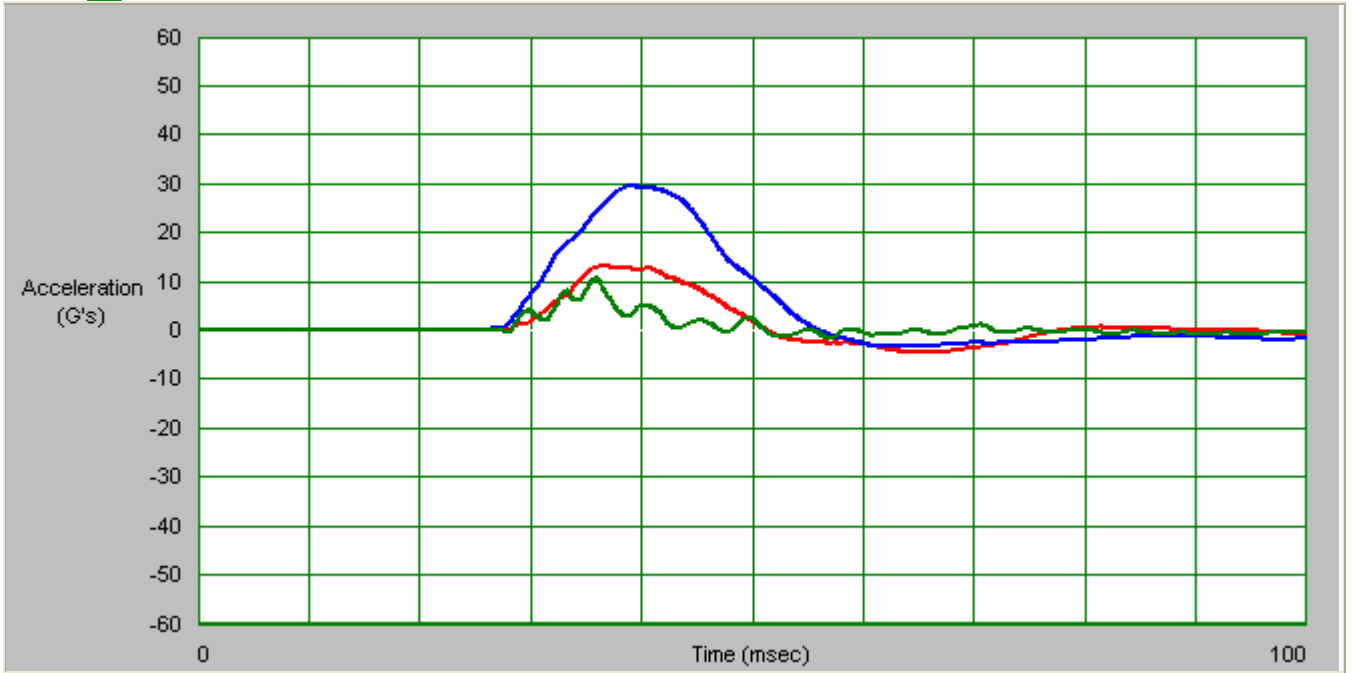



**KING DESIGN INDUSTRIAL CO., LTD.**  
 5F, NO. 3, Lane 270, Pei Shen Road Sec. 3,  
 Shen Keng Dist., New Taipei City, 222, Taiwan, R.O.C  
 TEL: 886-2-2662-5100 FAX: 886-2-2662-3094

**RELIABILITY TEST LABORATORY**  
<http://www.kdi.tw>  
<http://www.vibration.com.tw>  
 E-mail: service@kdi.tw

## Face-2

### Acceleration vs Time

	Channel Description:	G's	msec	In/S	Filter Hz	Max G's	Min G's
Ch1	Ch1	3.55	23.20	17.21	220.00	3.55	-1.92
Ch2	Ch2	33.35	23.80	184.82	220.00	33.35	-4.38
Ch3	Ch3	16.77	1.60	6.38	220.00	16.77	-9.95

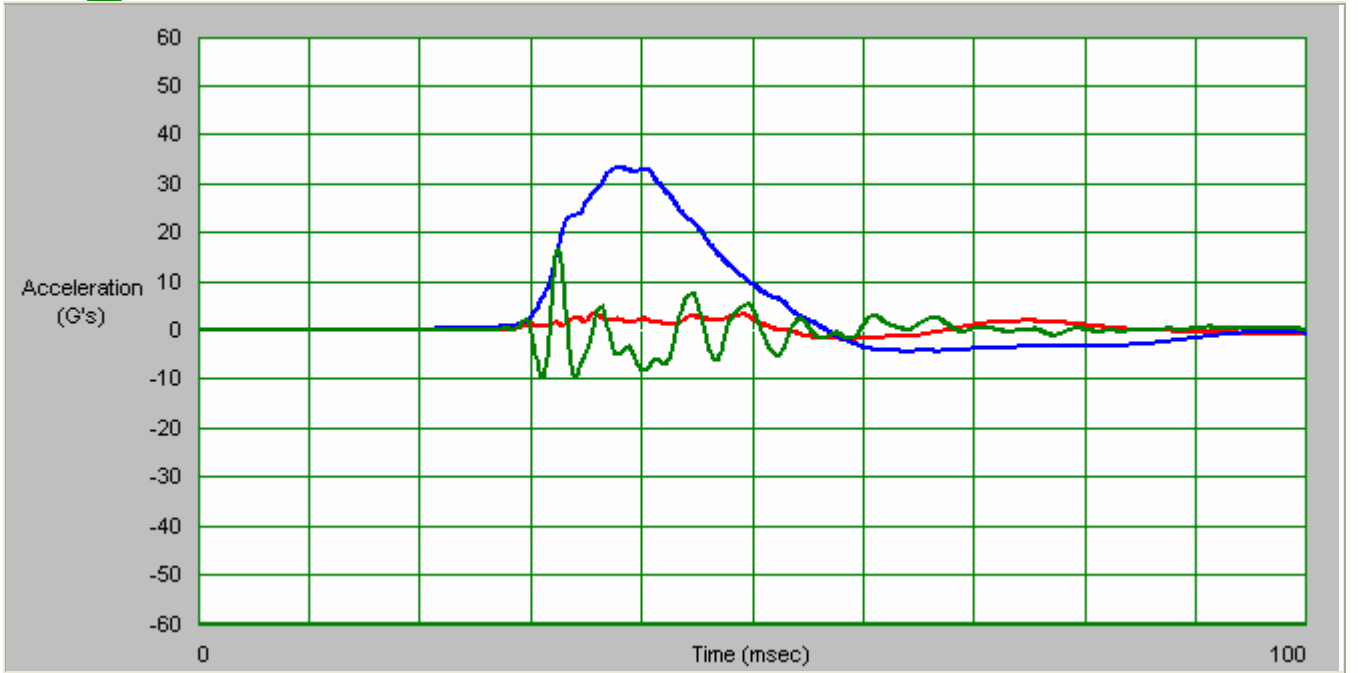

**KING DESIGN INDUSTRIAL CO., LTD.**

5F,NO. 3, Lane 270, Pei Shen Road Sec. 3,

Shen Keng Dist., New Taipei City, 222, Taiwan, R.O.C

TEL: 886-2-2662-5100 FAX: 886-2-2662-3094

**RELIABILITY TEST LABORATORY**
<http://www.kdi.tw>
<http://www.vibration.com.tw>

E-mail:service@kdi.tw

**Face-3**
**Acceleration vs Time**

	Channel Description:	G's	msec	In/S	Filter Hz	Max G's	Min G's
Ch1	Ch1	43.56	18.40	188.21	220.00	43.56	-6.04
Ch2	Ch2	3.15	12.00	6.73	220.00	3.15	-1.65
Ch3	Ch3	6.16	2.40	3.31	220.00	6.16	-5.21

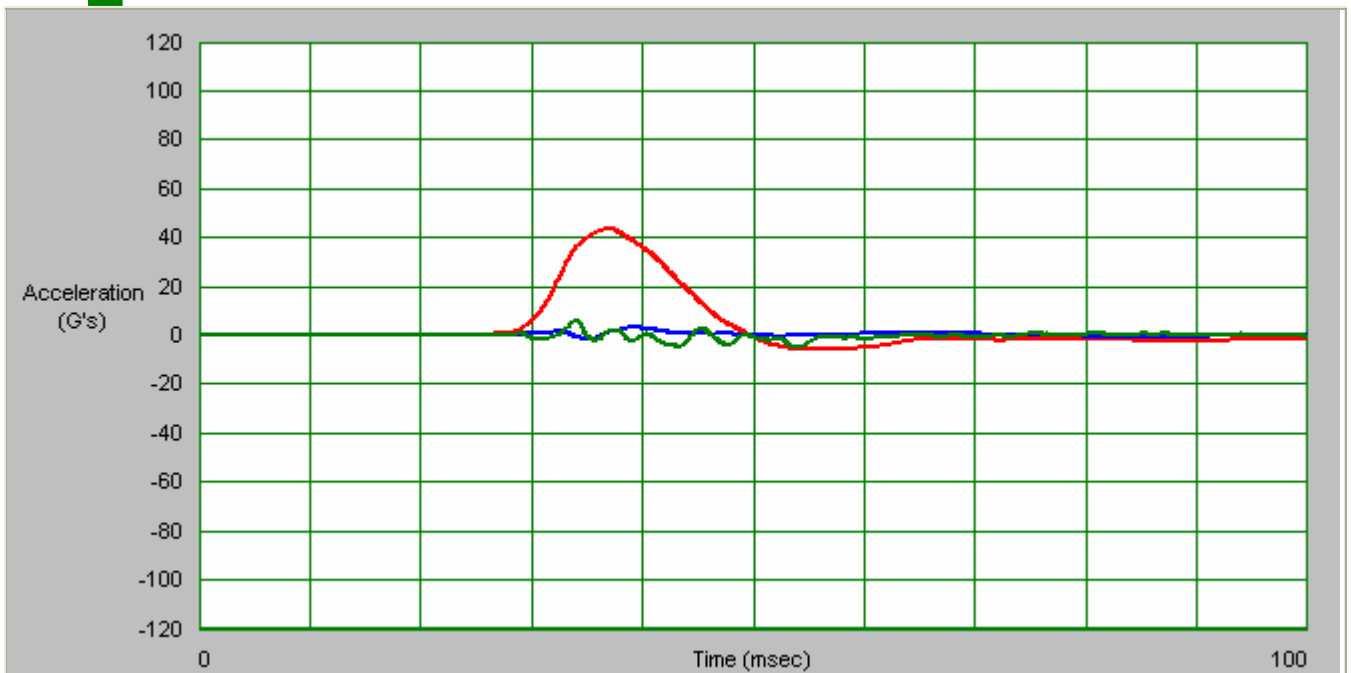

**KING DESIGN INDUSTRIAL CO., LTD.**

5F, NO. 3, Lane 270, Pei Shen Road Sec. 3,

Shen Keng Dist., New Taipei City, 222, Taiwan, R.O.C

TEL: 886-2-2662-5100 FAX: 886-2-2662-3094

**RELIABILITY TEST LABORATORY**
<http://www.kdi.tw>
<http://www.vibration.com.tw>

E-mail: service@kdi.tw

**Face-4**
**Acceleration vs Time**

	Channel Description:	G's	msec	In/S	Filter Hz	Max G's	Min G's
Ch1	Ch1	41.20	18.50	180.90	220.00	41.20	-8.42
Ch2	Ch2	7.46	12.00	18.57	220.00	7.46	-3.98
Ch3	Ch3	27.28	11.60	75.77	220.00	27.28	-9.48

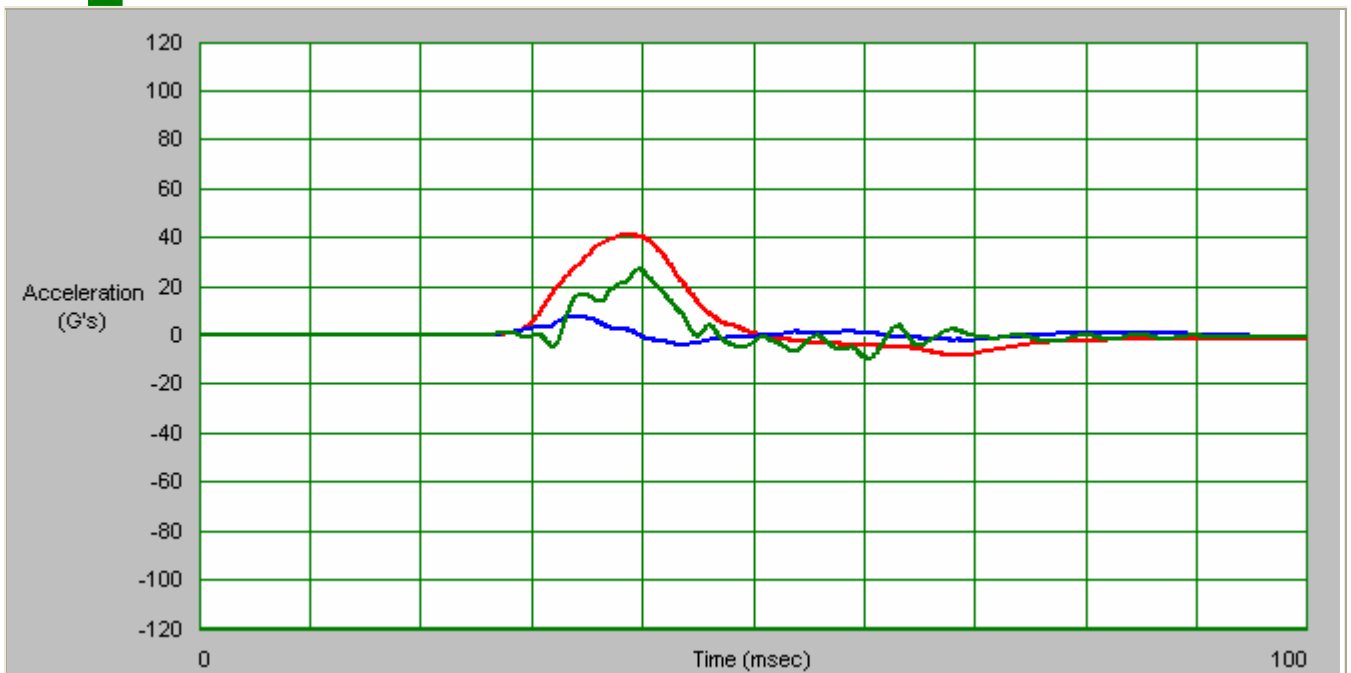

**KING DESIGN INDUSTRIAL CO., LTD.**

5F,NO. 3, Lane 270, Pei Shen Road Sec. 3,

Shen Keng Dist., New Taipei City, 222, Taiwan, R.O.C

TEL: 886-2-2662-5100 FAX: 886-2-2662-3094

**RELIABILITY TEST LABORATORY**
<http://www.kdi.tw>
<http://www.vibration.com.tw>

E-mail:service@kdi.tw

**Face-5**
**Acceleration vs Time**

	Channel Description:	G's	msec	In/S	Filter Hz	Max G's	Min G's
Ch1	Ch1	14.99	9.10	35.72	220.00	14.99	-14.29
Ch2	Ch2	16.48	14.20	48.26	220.00	16.48	-15.89
Ch3	Ch3	51.34	17.50	192.20	220.00	51.34	-18.38

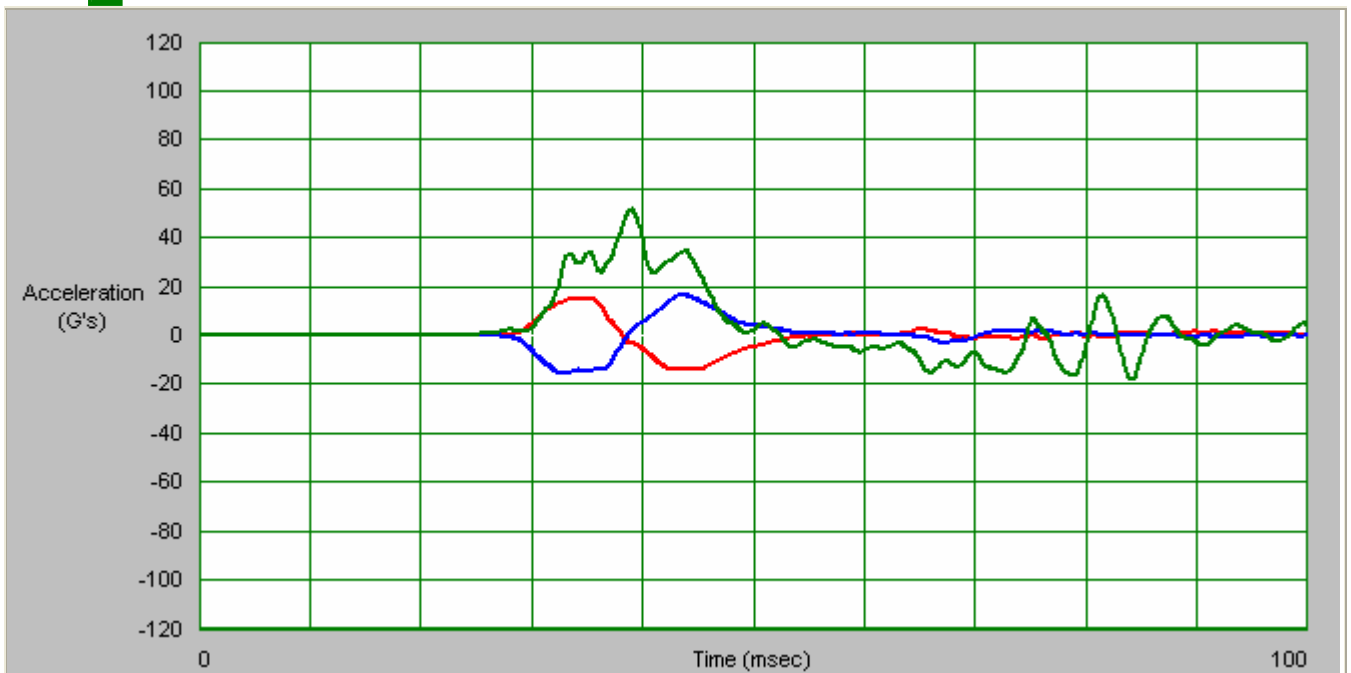



**KING DESIGN INDUSTRIAL CO., LTD.**

5F,NO. 3, Lane 270, Pei Shen Road Sec. 3,

Shen Keng Dist., New Taipei City, 222, Taiwan, R.O.C

TEL: 886-2-2662-5100 FAX: 886-2-2662-3094

**RELIABILITY TEST LABORATORY**
<http://www.kdi.tw>
<http://www.vibration.com.tw>

E-mail:service@kdi.tw

**Face-6**
**Acceleration vs Time**

	Channel Description:	G's	msec	In/S	Filter Hz	Max G's	Min G's
Ch1	Ch1	6.01	15.50	21.28	220.00	6.01	-5.29
Ch2	Ch2	12.00	7.10	21.42	220.00	12.00	-9.30
Ch3	Ch3	49.05	15.80	167.32	220.00	49.05	-16.50

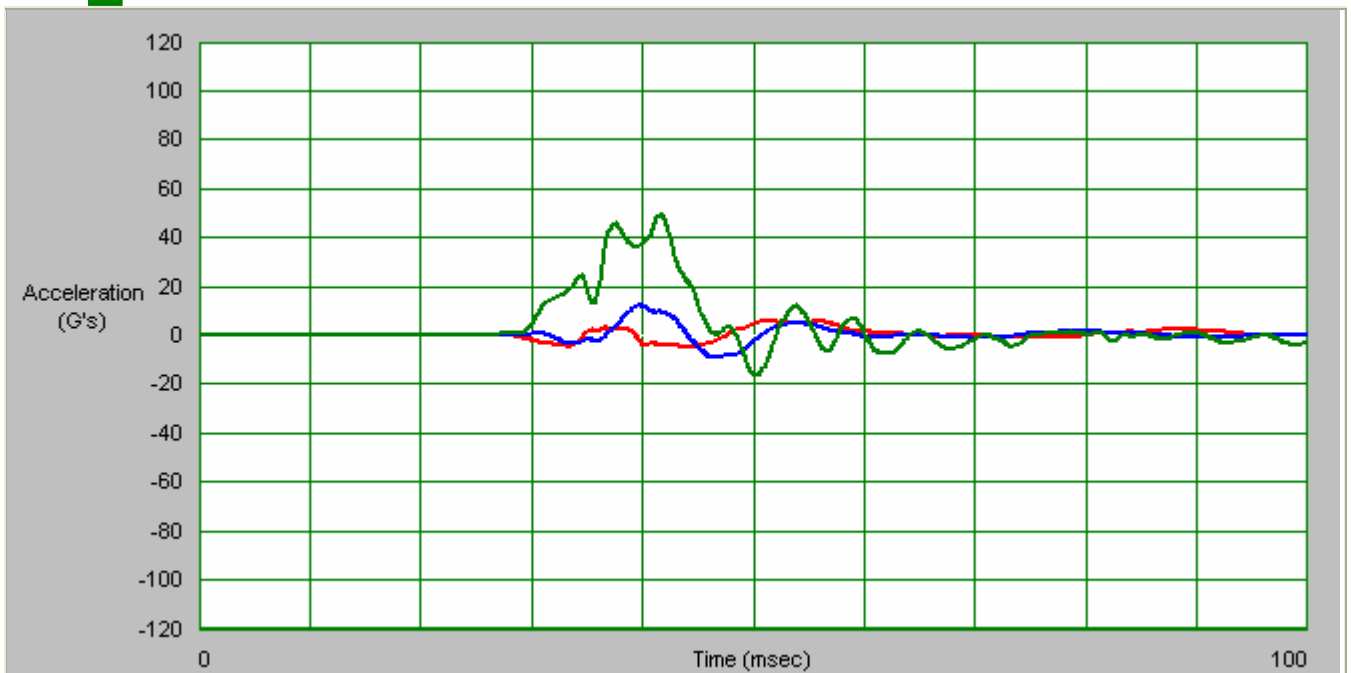
**-END-**