

Report NO:18I010004

# FWS-7360

## Intel® Denverton

### 1U Rackmount Network Appliance

#### Firewall Product

#### P5

### Compatibility Test Report

Summary	<input checked="" type="checkbox"/> Pass <input type="checkbox"/> Fail <input type="checkbox"/> Pass with Deviation (Comment: _____)			
Test Results Category				
	Critical	Major	Minor	Enhancement
Defect Found	0	0	0	0
Defect Unsolved	0	0	0	0

<b>Issue date</b>	<b>QE Manager</b>	<b>Test Engineer</b>
2018-06-14	KJ Wang	Aslenhsieh

**Summary Table of DTS:**

Defect No.	Severity	Description	Issue status

### Version Released Records

Date	Version	Change History	Note
01/27/2016	A0	1. First release	
01/06/2017	A1	1. Add NIM card compatibility test. 2. Add 10G · 40G LAN function test. 3. Update BIOS test plan. 4. Update Stability test item. 5. Add 10G, 40G Throughput performance test.	
07/17/2017	A2	1. Add Linux Burnintest 2. Add PCIe GEN3 bear card test	

**Note :**

For all test items in this report, 3 results have been defined and described as following:

- Pass:            Functionality work perfectly
- Fail:            Functionality failed and must be resolved in the next version
- N/A:            Functionality Not Applicable or Not Available

This test report would be updated when re-test completed in product next change version.

## Specification Validation

### Main Specification

Item	Specification	Result			Note
		Pass	Fail	N/A	
Form Factor	1U Rackmount 6-port Network Appliance	<input checked="" type="checkbox"/>	<input type="checkbox"/>	<input type="checkbox"/>	
Processor	Onboard Intel Denverton SoC C3758, option support 8 to 16 core	<input checked="" type="checkbox"/>	<input type="checkbox"/>	<input type="checkbox"/>	
System Memory	4 x 280-pin DDR4 2133MHz UDIMM/ECC UDIMM, Up to 64GB	<input checked="" type="checkbox"/>	<input type="checkbox"/>	<input type="checkbox"/>	
Ethernet	5 x RJ45 GbE (3 ports with I211, 2 ports from Marvell88E1543) (Additional 1 port with I211, colay with Mini-PCIe slots) 2 x 10G SFP+ Port (co-lay with 2 x RJ-45 GbE from Marvell88E1543)	<input checked="" type="checkbox"/>	<input type="checkbox"/>	<input type="checkbox"/>	
Bypass	2 pairs	<input checked="" type="checkbox"/>	<input type="checkbox"/>	<input type="checkbox"/>	
BIOS	AMI BIOS ROM	<input checked="" type="checkbox"/>	<input type="checkbox"/>	<input type="checkbox"/>	
Storage	2 x SATA III port on board 2.5"HDD Bay x 2	<input checked="" type="checkbox"/>	<input type="checkbox"/>	<input type="checkbox"/>	
Serial Port	1 x RJ45 console	<input checked="" type="checkbox"/>	<input type="checkbox"/>	<input type="checkbox"/>	
Universal Serial Bus	2 x USB 3.0 Type A on I/O side	<input checked="" type="checkbox"/>	<input type="checkbox"/>	<input type="checkbox"/>	
Expansion Interface	Mini-Card socket (full-size) with SIM socket x 1, option 2 Mini PCIe 1 x Mini-Card slot (PCIe/USB) with SIM slot, co-lay with RJ-45 LAN <b>※SATA is reserved</b> 1 x Mini-Card slot (PCIe/USB), co-lay with RJ-45 LAN <b>※SATA is reserved</b>	<input checked="" type="checkbox"/>	<input type="checkbox"/>	<input type="checkbox"/>	
RTC	Internal RTC	<input checked="" type="checkbox"/>	<input type="checkbox"/>	<input type="checkbox"/>	
TPM	TPM v1.2 9660/TPM2.0 9665 (optional)	<input checked="" type="checkbox"/>	<input type="checkbox"/>	<input type="checkbox"/>	
Watchdog Timer	1~255 step by software programmable	<input checked="" type="checkbox"/>	<input type="checkbox"/>	<input type="checkbox"/>	
GPIO	Reserve internal pin header 8-bit Digital I/O interface (4-in /4-out)	<input checked="" type="checkbox"/>	<input type="checkbox"/>	<input type="checkbox"/>	
Case Open	Pin Header	<input checked="" type="checkbox"/>	<input type="checkbox"/>	<input type="checkbox"/>	
Power Requirement	1 x 24-pin ATX power connector compatible with 20 pin type PSU	<input checked="" type="checkbox"/>	<input type="checkbox"/>	<input type="checkbox"/>	
Front I/O panel	2 x SFP+ with LED 5 x RJ45 Ethernet ports with LED 2 x USB 3.0 1 x RJ45 console 1 x Software Programmable button LCM 5 x LED for Power/HDD/ Status/ Bypass 1 x NIM slot	<input checked="" type="checkbox"/>	<input type="checkbox"/>	<input type="checkbox"/>	
Rear I/O panel	Power Switch 1 x AC Input	<input checked="" type="checkbox"/>	<input type="checkbox"/>	<input type="checkbox"/>	

**O.S. Support**

Item	Specification	Result			Note
		Pass	Fail	N/A	
Microsoft Windows	Windows 10 Enterprise 64 bits	<input checked="" type="checkbox"/>	<input type="checkbox"/>	<input type="checkbox"/>	
Linux	CentOS7 kernel:3.10.0-693.el7.x86_64	<input checked="" type="checkbox"/>	<input type="checkbox"/>	<input type="checkbox"/>	Testing environment 1. Linux as first priority
	Ubuntu16.04 x86_64 kernel 4.4.0-21-generic	<input checked="" type="checkbox"/>	<input type="checkbox"/>	<input type="checkbox"/>	

### Platform Information

Item	Device Information	Note
Product of department	NSD	
System Model	FWS-7360	
PCB Model / Version	NMB-7360 A0.1	
BIOS / Version	FWS-7360 R0.2 (K736AM02) (02/09/2018) FWS-7360 R1.0 (K736AM10) (05/17/2018) FWS-7360 R1.1 (K736AM11) (06/08/2018)	
Driver folder	\\nas3\sap-beta\Products\FWS-7360	
CPU Type	Intel® Atom™ CPU C3858 @ 2.0 GHz	
Memory Type	Transcend DDR4 2400 16GB SEC 546 K4A8G085WB BCRC	
SATA HDD	Intel SSD530 2.5". 120GB.SATA III SSD MLC	
	Transcend TS128GSSD370 2.5".128GB.SATA III SSD MLC.	
USB DVD-ROM	BUFFALO BDXL-PC6U2	
VGA Monitor	LG Flatron E2260 / 1920*1080 / 22" monitor	
	Asus PA238Q / 1920*1080 / 23" monitor	
Operating System	<input checked="" type="checkbox"/> CentOS7 kernel: 3.10.0-693.el7.x86_64	
	<input checked="" type="checkbox"/> Ubuntu16.04 x86_64 kernel 4.4.0-62-generic	
	<input checked="" type="checkbox"/> Windows 10 Enterprise 64bit English version	
Power Supply	ATX Power Supply : be quiet Straight Power E7 Golden 550W/ATX	
	Adapter : N/A	
<b>Chipset Information</b>		
SOC Chip	Denverton up to 12 core	
Super IO Chipset	ITE IT8728F/CX	
Ethernet Chipset	Intel i210IS/11AT & Marvell88E1543	

## Summary Table of contents:

1. Hardware Compatibility Test .....	8
1.1. CPU Compatibility Test .....	8
1.2. Memory Compatibility Test.....	8
1.3. SATA Compatibility Test .....	9
2. Basic Function Test.....	10
2.1. CPU Function Test.....	10
2.2. Memory Function Test .....	10
2.3. SATA Function Test .....	11
2.4. Video Function Test .....	11
2.5 Console Function Test.....	12
2.6 Com Port Function Test .....	12
2.7 USB ports Function Test .....	12
2.8 LED / LCM / Button Function Test .....	13
2.9. Bypass Function Test .....	14
2.10. LAN Function Test .....	15
2.11. Digital IO Function Test.....	16
2.12. TPM2.0 Function Test .....	16
2.13. Jumper and connector Function Test .....	17
3. Expansion card and Application Test .....	18
3.1. PCI-Express Bear Card Test: .....	18
3.2. Mini PCIe Compatibility Test:.....	18
3.3. Expansion Card Integration Test .....	18
4. Time Accuracy Test.....	19
4.1. System Clock & RTC Clock Test.....	19
5. Power Consumption Test .....	20
5.1. Power Consumption.....	20
5.2. PC Health Status .....	20
5.3. CMOS Battery Test .....	21
6. O.S Compatibility Test .....	22
6.1. Linux OS Compatibility Test .....	22
6.2. Windows OS Compatibility Test.....	24
7. BIOS Function Test .....	25
7.1. Flash BIOS .....	25
7.2. Advanced Test .....	25
7.3. Chipset Test.....	26
7.4. Boot Test .....	26
7.5. Clear CMOS and Load Default Test.....	26
7.6. AAEON Tag Check Utility.....	26
7.7. Supervisor / User Password Test .....	26
7.8. Negative Test.....	27
8. Stability Test.....	28
8.1. Run in Test.....	28
8.2. Cold Boot Test .....	28
8.3. Memory Test.....	29
9. 1G LAN Performance Test .....	30
9.1 DUT and Test Equipment .....	30
9.2 RFC-2544 performance test (2 port) .....	31
9.3 RFC-2544 performance test (6 ports).....	32
9.4 LAN Endurance Test .....	34

# 1. Hardware Compatibility Test

## 1.1. CPU Compatibility Test

Procedure:

Step1. Check CPU information and frequency should show correct value during POST screen and O.S.

<Linux CPU info # dmidecode -t processor|grep "Version:">

Step2. CPU supported must meet specification.

Test Result:

Test item	Result			Note
	Pass	Fail	N/A	
Below CPU information and frequency should show correct value				
Intel® Atom™ CPU C3758 @ 2.20 GHz	<input checked="" type="checkbox"/>	<input type="checkbox"/>	<input type="checkbox"/>	
Intel® Atom™ CPU C3858 @ 2.0 GHz	<input checked="" type="checkbox"/>	<input type="checkbox"/>	<input type="checkbox"/>	
Intel® Atom™ CPU C3958 @ 2.0 GHz	<input checked="" type="checkbox"/>	<input type="checkbox"/>	<input type="checkbox"/>	

## 1.2. Memory Compatibility Test

Procedure:

Step1. Boot up function test

Step2. Check Memory frequency should show correct value during POST screen and O.S.

<<Linux Memory info # dmidecode -t memory|grep "Size:">

Step3. Memory supported must meet specification.

Test Result:

Test item	AAEON P/N	Result			Note
		Pass	Fail	N/A	
a. Boot up normal.					
b. Below Memory Information and frequency should show correct value.					
U-DIMM					
Transcend DDR4 2133 8GB SEC 449 K4A4G085WD BCPB	N/A	<input checked="" type="checkbox"/>	<input type="checkbox"/>	<input type="checkbox"/>	
Transcend DDR4 2133 4GB SEC 446 K4A4G085WD BCPB	N/A	<input checked="" type="checkbox"/>	<input type="checkbox"/>	<input type="checkbox"/>	
Transcend DDR4 2400 16GB SEC 546 K4A8G085WB BCRC	N/A	<input checked="" type="checkbox"/>	<input type="checkbox"/>	<input type="checkbox"/>	
Transcend DDR4 2400 4GB SEC 637 K4A4G085WE BCRC	N/A	<input checked="" type="checkbox"/>	<input type="checkbox"/>	<input type="checkbox"/>	
Innodisk DDR4 2133 8GB M4U0-8GSSOCR-26 SEC 449 K4A4G085WD BCPB	N/A	<input checked="" type="checkbox"/>	<input type="checkbox"/>	<input type="checkbox"/>	
Innodisk DDR4 2133 4GB M4U0-4GSSNCRG-26 SEC 449 K4A4G085WD BCPB	N/A	<input checked="" type="checkbox"/>	<input type="checkbox"/>	<input type="checkbox"/>	
DSL DDR4 2133 8GB CL15 SEC 446 K4A4G085WD BCPB	N/A	<input checked="" type="checkbox"/>	<input type="checkbox"/>	<input type="checkbox"/>	
DSL DDR4 2133 4GB CL15 SEC 446 K4A4G085WD BCPB	N/A	<input checked="" type="checkbox"/>	<input type="checkbox"/>	<input type="checkbox"/>	
Crucial CT16G4SFD8213.16FA1 16GB DDR4-2133 SODIMM 1.2V CL15	N/A	<input checked="" type="checkbox"/>	<input type="checkbox"/>	<input type="checkbox"/>	



### 1.3. SATA Compatibility Test

#### 1.3.1 SATA AHCI Mode

Procedure:

Step1. BIOS select AHCI mode, check SATA devices information/ size should show correct value in BIOS setup.

Step2. Boot into OS, check SATA devices information/size should show correct value.

OS: Ubuntu16.04.2 kernel:4.4.0-62-generic x86\_64

Test Result:

Test item	Result			Note	
	Pass	Fail	N/A		
Below SATA devices information and size should show correct value with UEFI mode.					
SATAII	TOSHIBA MK3276GSX 2.5" 320GB	<input checked="" type="checkbox"/>	<input type="checkbox"/>	<input type="checkbox"/>	
SATAII	Seagate ST9160412AS 2.5" 160GB	<input checked="" type="checkbox"/>	<input type="checkbox"/>	<input type="checkbox"/>	
SATAIII	TOSHIBA MQ01ABF032 2.5" 320GB	<input checked="" type="checkbox"/>	<input type="checkbox"/>	<input type="checkbox"/>	
SATAIII	WD WD5000BPKX 2.5" 500GB	<input checked="" type="checkbox"/>	<input type="checkbox"/>	<input type="checkbox"/>	
SATAIII	HGST HTS541010A9E680 2.5" 1TB	<input checked="" type="checkbox"/>	<input type="checkbox"/>	<input type="checkbox"/>	
SSD	Intel® SSD 530 Series (120GB, 2.5in SATA 6Gb/s, 20nm, MLC)	<input checked="" type="checkbox"/>	<input type="checkbox"/>	<input type="checkbox"/>	
SSD	OCZ / TRN100-25SAT3-240G 2.5" SATA 3 6Gb/s	<input checked="" type="checkbox"/>	<input type="checkbox"/>	<input type="checkbox"/>	
SSD	Transcend TS32GSSD370 2.5".32GB.SATA III SSD MLC.	968C032G2D	<input checked="" type="checkbox"/>	<input type="checkbox"/>	<input type="checkbox"/>
SSD	Transcend.TS64GSSD370 2.5".64GB. SATA III.SSD.MLC	968C64G003	<input checked="" type="checkbox"/>	<input type="checkbox"/>	<input type="checkbox"/>
SSD	Transcend.TS128GSSD370 2.5" SATA3 SSD.128GB.MLC.	968C128G0W	<input checked="" type="checkbox"/>	<input type="checkbox"/>	<input type="checkbox"/>
SSD	Innodisk. 3MG2-P 2.5" 16GB MLC SATA SSD 15nm. DGS25-16GD81BC3SC-26	AP-SS968C016G3 K	<input checked="" type="checkbox"/>	<input type="checkbox"/>	<input type="checkbox"/>
SSD	Innodisk. 3MG2-P 2.5" 32GB MLC SATA SSD 15nm. DGS25-32GD81BC3DC-26	AP-SS968C032G1 P	<input checked="" type="checkbox"/>	<input type="checkbox"/>	<input type="checkbox"/>
SSD	Innodisk. 3MG2-P 2.5" 64GB MLC SATA SSD 15nm. DGS25-64GD81BC3QC-26	968C064G39	<input checked="" type="checkbox"/>	<input type="checkbox"/>	<input type="checkbox"/>
SSD	Innodisk. 3MG2-P 2.5" 128GB MLC SATA SSD 15nm. DGS25-A28D81BC3QC-26	AP-SS968C128G1 P	<input checked="" type="checkbox"/>	<input type="checkbox"/>	<input type="checkbox"/>
SSD	Innodisk. 3MG2-P 2.5" 256GB. MLC SATA SSD 15nm. DGS25-B56D81BC3QC-26	AP-SS968C256G1 6	<input checked="" type="checkbox"/>	<input type="checkbox"/>	<input type="checkbox"/>

## 2. Basic Function Test

### 2.1. CPU Function Test

Configuration:

CPU: Intel® Atom™ CPU C3858 @ 2.0 GHz

Memory: Transcend DDR4 2400 16GB SEC 546 K4A8G085WB BCRC

Procedure:

Step1. Connected CPU with product specification max supported.

Step2. Boot into BIOS manual and check CPU information is correct.

Step4. Confirm CPU max speed can meet CPU specification in OS environment.

<#watch -n 1 "cat /proc/cpuinfo | grep MHz">

Step5. Install and execute benchmark AP "sysbench", recode the benchmark.

<1 thread #sysbench --test=cpu --cpu-max-prime=20000 run>

<8 threads #sysbench --test=cpu --cpu-max-prime=20000 --num-threads=4 run>

Test result:

No.	Test item	Result			Note
		Pass	Fail	N/A	
1	System can boot properly	<input checked="" type="checkbox"/>	<input type="checkbox"/>	<input type="checkbox"/>	
2	BIOS\CPU information is correct.	<input checked="" type="checkbox"/>	<input type="checkbox"/>	<input type="checkbox"/>	
3	CPU speed should meet specification	<input checked="" type="checkbox"/>	<input type="checkbox"/>	<input type="checkbox"/>	
4	Recode CPU Benchmark	Intel	1 thread	25.2058 s	
		2.20 G	4 threads	6.3095 s	

### 2.2. Memory Function Test

Configuration:

CPU: Intel® Atom™ CPU C3858 @ 2.0 GHz

Memory: Transcend DDR4 2400 16GB SEC 546 K4A8G085WB BCRC

Procedure:

Step1. Connected memory with product specification max supported.

Step2. Boot into BIOS manual and check memory information is correct.

Step3. Slot test.

Step4. Execute benchmark AP" sysbench", recode the benchmark.

<read # sysbench --test=memory --memory-block-size=8K --memory-total-size=1G --memory-oper=read run >

<write # sysbench --test=memory --memory-block-size=8K --memory-total-size=1G run >

Test result:

No.	Test item	Result			Note
		Pass	Fail	N/A	
1	System should boot properly.	<input checked="" type="checkbox"/>	<input type="checkbox"/>	<input type="checkbox"/>	
2	BIOS\Memory information is correct.	<input checked="" type="checkbox"/>	<input type="checkbox"/>	<input type="checkbox"/>	
3	Slot 1	System should boot up properly.	<input checked="" type="checkbox"/>	<input type="checkbox"/>	<input type="checkbox"/>
	Slot 2		<input checked="" type="checkbox"/>	<input type="checkbox"/>	<input type="checkbox"/>
	Slot 3		<input checked="" type="checkbox"/>	<input type="checkbox"/>	<input type="checkbox"/>
	Slot 4		<input checked="" type="checkbox"/>	<input type="checkbox"/>	<input type="checkbox"/>
4.	Recode Memory Benchmark	read	Transferred:21208.37MB/s Total time:0.0368 s		
		write	Transferred:3724.34MB/s		

			Total time:0.2624s	
--	--	--	--------------------	--

### 2.3. SATA Function Test

Configuration:

SATA: Transcend TS128GSSD370 2.5".128GB.SATA III SSD MLC.

Procedure:

- Step1. Connect SATA HDD / SSD and CF.
- Step2. Boot into BIOS manual and check SATA/CF information is correct.
- Step3. Install Linux OS with SATA storage / CF.
- Step4. Check SATA/CF read/write speed can meet the specification.
  - <update# apt-get update>
  - <check HDD# fdisk -l>
  - <Read command#: hdparm -t /dev/sda>
  - <Write command#: hdparm -t --direct /dev/sda>

Test result:

No.	Test item	Result			Note
		Pass	Fail	N/A	
1	SATA storage and CF information should correct during POST and OS.	<input checked="" type="checkbox"/>	<input type="checkbox"/>	<input type="checkbox"/>	
2	SATA ports speed should meet specification. (SATAII max read speed > 150MB/s) (SATAIII max read speed> 300MB/s)	<input checked="" type="checkbox"/>	<input type="checkbox"/>	<input type="checkbox"/>	SATA 1 port Read: 390.27 MB/s Write: 462.77 MB/s
3	mSATA R/W speed should meet specification.	<input type="checkbox"/>	<input type="checkbox"/>	<input checked="" type="checkbox"/>	Read: MB/s Write: MB/s

### 2.4. Video Function Test

Procedure:

- Step1. Connect mini PCI-E to PCI-E x1 display card
- Step2. Connect VGA monitor.
- Step3. Install Linux OS to DUT system.
- Step4. After installation and boot to Linux OS for test X-windows mode and Text mode.
- Step5. Check EDID function if kernel supported.

Test result:

No.	Test item		Result			Note
			Pass	Fail	N/A	
1	Display shouldn't loss during OS installation.	VGA	<input type="checkbox"/>	<input type="checkbox"/>	<input checked="" type="checkbox"/>	
		HDMI	<input type="checkbox"/>	<input type="checkbox"/>	<input checked="" type="checkbox"/>	
2	Display shouldn't flicker during POST and OS.	VGA	<input type="checkbox"/>	<input type="checkbox"/>	<input checked="" type="checkbox"/>	
		HDMI	<input type="checkbox"/>	<input type="checkbox"/>	<input checked="" type="checkbox"/>	
3	VGA should display normal with x-window and text mode.		<input type="checkbox"/>	<input type="checkbox"/>	<input checked="" type="checkbox"/>	
4	HDMI should display normal with x-window and text mode.		<input type="checkbox"/>	<input type="checkbox"/>	<input checked="" type="checkbox"/>	
5.	VGA EDID should function properly		<input type="checkbox"/>	<input type="checkbox"/>	<input checked="" type="checkbox"/>	
6	HDMI EDID should function properly		<input type="checkbox"/>	<input type="checkbox"/>	<input checked="" type="checkbox"/>	

## 2.5 Console Function Test

Procedure:

- Step1. Execute “Hyper-Terminal” in HOST PC.
- Step2. Boot up DUT system and press ESC key of HOST keyboard to boot into BIOS manual.
- Step3. To check HOST keyboard can control properly in BIOS manual.
- Step4. DUT boot to DOS (USB flash) and check console redirection work properly.
- Step5. Under Linux OS, install minicom AP and check console transmission.

Test Result:

No.	Test item	Result			Note
		Pass	Fail	N/A	
1	Console support BIOS display and control.	<input checked="" type="checkbox"/>	<input type="checkbox"/>	<input type="checkbox"/>	Test with 9600/38400/115200
2	Console support UEFI display and command typing.	<input checked="" type="checkbox"/>	<input type="checkbox"/>	<input type="checkbox"/>	Test with 9600/38400/115200
3	Under Linux OS, console support minicom transmission.	<input checked="" type="checkbox"/>	<input type="checkbox"/>	<input type="checkbox"/>	Test with 9600/38400/115200 ttyS0

## 2.6 Com Port Function Test

Procedure:

- Step1. Execute “Hyper-Terminal” in Server PC.
- Step2. Install “minicom” on DUT. <apt-get install minicom or yum install minicom>
- Step3. To run “minicom” and set com port for test. (#minicom -s )(com1=ttyS0; com2=ttyS1....)
- Step4. Connect “Null cable” between Server PC and DUT.
- Step5. Transmit words between server and DUT.

Test Result:

No.	Test item	Result			Note
		Pass	Fail	N/A	
1	Transmission words should not loss or error.	<input checked="" type="checkbox"/>	<input type="checkbox"/>	<input type="checkbox"/>	COM1: ttyS0

## 2.7 USB ports Function Test

### 2.7.1 USB basic function test

Procedure:

- Step1. Connect USB keyboard and check it works properly under BIOS/DOS/Linux.
- Step2. Connect USB DVD ROM, check system can boot from USB DVD ROM and USB DVD ROM can work properly under Linux OS.
- Step3. Connect USB2.0/3.0 Flash, check system can boot from USB flash and USB flash can work properly under Linux OS.
- Step4. Check USB2.0/3.0 flash read speed can meet the Flash specification.  
<Read command#: hdparm -t /dev/sdb>

Test Result:

No.	Test item	Result			Note
		Pass	Fail	N/A	
1	Boot from USB DVD ROM and drive should work properly.	<input checked="" type="checkbox"/>	<input type="checkbox"/>	<input type="checkbox"/>	USB1/2
2	USB 1.1 / 2.0 /3.0 devices (Flash, keyboard,	<input checked="" type="checkbox"/>	<input type="checkbox"/>	<input type="checkbox"/>	USB1/2

	mouse, DVD ROM) can work properly on USB 3.0 ports.				
3	USB3.0 R/W speed should meet specification.	<input checked="" type="checkbox"/>	<input type="checkbox"/>	<input type="checkbox"/>	USB1 Read:126.06 MB/s

### 2.7.2 USB compatibility test

Procedure:

Step1. Insert USB device to USB2.0 / 3.0 ports.

Step2. Test each USB device function.

Test Result

Test Item		Result			Note
		Pass	Fail	N/A	
USB devices function should work properly.					
keyboard	Microsoft 1366	<input checked="" type="checkbox"/>	<input type="checkbox"/>	<input type="checkbox"/>	
Mouse	Microsoft MSK-1113(B)	<input checked="" type="checkbox"/>	<input type="checkbox"/>	<input type="checkbox"/>	
DVD ROM	BUFFALO BDXL-PC6U2	<input checked="" type="checkbox"/>	<input type="checkbox"/>	<input type="checkbox"/>	
HUB	Mini 4ports HUB High speed USB2.0	<input checked="" type="checkbox"/>	<input type="checkbox"/>	<input type="checkbox"/>	
HDD	Transcend TS500GSJ25D3 USB3.0 500GB	<input checked="" type="checkbox"/>	<input type="checkbox"/>	<input type="checkbox"/>	
USB2.0 Flash	Sandisk cruzer 8GB	<input checked="" type="checkbox"/>	<input type="checkbox"/>	<input type="checkbox"/>	
	TDK 16GB	<input checked="" type="checkbox"/>	<input type="checkbox"/>	<input type="checkbox"/>	
USB3.0 Flash	Sandisk SDCZ80 64GB	<input checked="" type="checkbox"/>	<input type="checkbox"/>	<input type="checkbox"/>	
	Apacer AH450 32GB	<input checked="" type="checkbox"/>	<input type="checkbox"/>	<input type="checkbox"/>	

### 2.8 LED / LCM / Button Function Test

Procedure:

Step1. Check power LED when system power on.

Step2. Check HDD LED blinks when install OS to HDD/CF.

Step3. Check Bypass LED when AAeon Test AP set Bypass status.

Step4. Check Test AP resume are correct which press LCM function button.  
(Up/Down/ESC/Enter)

Step5. Check Test AP resume is correct which press program reset button.

SDK: Button <1. #make clean 2. # make 3. # ./button>

Step6. Check status LED action same with Test AP setting.

Step7. To check Ethernet LED status can follow below methods.

- A. Use LAN cable to connect 1GB switch between Server PC and DUT, transmit some packets between Server PC and DUT.
- B. Use LAN cable to connect 100MB switch between Server PC and DUT, transmit some packets between Server PC and DUT.
- C. Use LAN cable to connect 10MB switch between Server PC and DUT, transmit some packets between Server PC and DUT.

	Speed LED
40GB/s	Color Blue
10GB/s	Color Blue
1GB/s	Color Orange
100MB/s	Color Green
10MB/s	Color Blank

	Link/Act LED
Un-Linked	Blank

Linked	TBD
Transmit	LED Blink

Result:

No.	Test item	Result			Remark
		Pass	Fail	N/A	
1	Power LED should turn on when system power on.	<input checked="" type="checkbox"/>	<input type="checkbox"/>	<input type="checkbox"/>	
2	HDD LED should blinks when install OS to HDD and CF.	<input checked="" type="checkbox"/>	<input type="checkbox"/>	<input type="checkbox"/>	
3	Bypass LED should turn on when SDK set bypass status.	<input checked="" type="checkbox"/>	<input type="checkbox"/>	<input type="checkbox"/>	
4	Status LED color and action should same with SDK setting.	<input checked="" type="checkbox"/>	<input type="checkbox"/>	<input type="checkbox"/>	SDK: LED
5	Reset value of SDK should show high when press the program reset button.	<input checked="" type="checkbox"/>	<input type="checkbox"/>	<input type="checkbox"/>	Open: show high Press: show low
6	LCM value of SDK should show correct when press LCM function button.	<input checked="" type="checkbox"/>	<input type="checkbox"/>	<input type="checkbox"/>	SDK: LCM ./lcm -getkey return ./lcm -lcm on ./lcm -lcm off ./lcm -set String
7	10G connection LAN LED action as below: Speed LED: Green Link LED: Blue / Blinking	<input checked="" type="checkbox"/>	<input type="checkbox"/>	<input type="checkbox"/>	
8	1000M connection LAN LED action as below: Speed LED: Orange Link LED: Yellow / Blinking	<input checked="" type="checkbox"/>	<input type="checkbox"/>	<input type="checkbox"/>	
9	100M connection LAN LED action as below: Speed LED: Green Link LED: Yellow / Blinking	<input checked="" type="checkbox"/>	<input type="checkbox"/>	<input type="checkbox"/>	
10	10M connection LAN LED action as below: Speed LED: blank Link LED: Yellow / Blinking	<input checked="" type="checkbox"/>	<input type="checkbox"/>	<input type="checkbox"/>	

## 2.9. Bypass Function Test

Procedure:

- Step1. Under Linux, execute AAEON SDK(LanByPass) to test Bypass function under power on and power off mode.
- Step2. SDK set "power on" is "PassTru and "power off" is "ByPass, and remove the AC power cord. (G3 status)
- Step3. BIOS set power on is "PassTru" and power off is "Bypass", boot up system from G3 status..
- Step4. SDK set "power on" is "PassTru" and "WDT-ByPass", execute watch Dog.
- Step5. SDK set "save to BIOS" and reboot to BIOS, check BIOS Bypass value.

Test result:

No.	Test item	Power on	Power off	Result			Remark
				Pass	Fail	N/A	

1	PassTru / ByPass should work properly by SDK control.	Bypass	Bypass	<input checked="" type="checkbox"/>	<input type="checkbox"/>	<input type="checkbox"/>	SDK: LanByPass
		Bypass	PassTru	<input checked="" type="checkbox"/>	<input type="checkbox"/>	<input type="checkbox"/>	
		PassTru	Bypass	<input checked="" type="checkbox"/>	<input type="checkbox"/>	<input type="checkbox"/>	
		PassTru	PassTru	<input checked="" type="checkbox"/>	<input type="checkbox"/>	<input type="checkbox"/>	
2	LAN should switch to ByPass mode when system AC loss.( G3 status)	PassTru	ByPass	<input checked="" type="checkbox"/>	<input type="checkbox"/>	<input type="checkbox"/>	
3	Boot up from G3, LAN should switch to PassTru.	PassTru	ByPass	<input checked="" type="checkbox"/>	<input type="checkbox"/>	<input type="checkbox"/>	
4	WDT ByPass should work properly.			<input checked="" type="checkbox"/>	<input type="checkbox"/>	<input type="checkbox"/>	
5	Save to BIOS			<input checked="" type="checkbox"/>	<input type="checkbox"/>	<input type="checkbox"/>	

### 2.10. LAN Function Test

Configuration:

- 1G switch: D-Link DGS-1210-16
- 100M switch D-Link DES-1008A
- 10M HUB SVEC FD916H
- 100 meters CAT6 cable

Procedure:

(PXE and WOL support or not, define in SPEC)

- Step1. Each LAN port connect DHCP server. ; 10G & 40G LAN port connect to Host PC
  - Step2. Connect internet and ping Google (8.8.8.8) ; 10G & 40G ping Host PC.
  - Step3. Each LAN port connect host PXE PC and DUT BIOS enable PXE function.
  - Step4. BIOS select boot from LAN.
  - Step5. Test each LAN port WOL function properly which from OS shutdown.
  - Step6. Client PC to install and execute iperf3 and host PC execute iperf3 -s
  - Step7. Iperf test with 1G, 100M, 10M switch/Hub. ; 10G & 40G iperf test with Host PC.
- ```
<#yum install iperf>
<#iperf3 -c 192.168.3.58 -w 100M -i 1 -t 120 >
```

Test result:

| Test item                                                                                           | LAN 1~2 1G                          |                          |                          | LAN 3~4 1G                          |                          |                                     | LAN 5~8 1G                          |                          |                                     | Note      |
|-----------------------------------------------------------------------------------------------------|-------------------------------------|--------------------------|--------------------------|-------------------------------------|--------------------------|-------------------------------------|-------------------------------------|--------------------------|-------------------------------------|-----------|
|                                                                                                     | Pass                                | Fail                     | N/A                      | Pass                                | Fail                     | N/A                                 | Pass                                | Fail                     | N/A                                 |           |
| Internet Browser (DHCP Server)<br>Ping website(8.8.8.8) should work properly                        | <input checked="" type="checkbox"/> | <input type="checkbox"/> | <input type="checkbox"/> | <input checked="" type="checkbox"/> | <input type="checkbox"/> | <input type="checkbox"/>            | <input checked="" type="checkbox"/> | <input type="checkbox"/> | <input type="checkbox"/>            |           |
| LAN Boot (PXE)<br>Boot from LAN should work properly                                                | <input checked="" type="checkbox"/> | <input type="checkbox"/> | <input type="checkbox"/> | <input type="checkbox"/>            | <input type="checkbox"/> | <input checked="" type="checkbox"/> | <input type="checkbox"/>            | <input type="checkbox"/> | <input checked="" type="checkbox"/> | LAN1/LAN2 |
| Wake On LAN<br>WOL should work properly when resume from S5                                         | <input checked="" type="checkbox"/> | <input type="checkbox"/> | <input type="checkbox"/> | <input checked="" type="checkbox"/> | <input type="checkbox"/> | <input type="checkbox"/>            | <input checked="" type="checkbox"/> | <input type="checkbox"/> | <input type="checkbox"/>            |           |
| 1Gbps connection<br>Iperf test result should not loss and max bandwidth must be in 900Mbps or more. | <input checked="" type="checkbox"/> | <input type="checkbox"/> | <input type="checkbox"/> | <input checked="" type="checkbox"/> | <input type="checkbox"/> | <input type="checkbox"/>            | <input checked="" type="checkbox"/> | <input type="checkbox"/> | <input type="checkbox"/>            |           |

|                                                                                                      |                                     |                          |                          |                                     |                          |                          |                                     |                          |                          |  |
|------------------------------------------------------------------------------------------------------|-------------------------------------|--------------------------|--------------------------|-------------------------------------|--------------------------|--------------------------|-------------------------------------|--------------------------|--------------------------|--|
| 100Mbps connection<br>Iperf test result should not loss and max bandwidth must be in 90Mbps or more. | <input checked="" type="checkbox"/> | <input type="checkbox"/> | <input type="checkbox"/> | <input checked="" type="checkbox"/> | <input type="checkbox"/> | <input type="checkbox"/> | <input checked="" type="checkbox"/> | <input type="checkbox"/> | <input type="checkbox"/> |  |
| 10Mbps connection<br>Iperf test result should not loss and max bandwidth must be in 9Mbps or more.   | <input checked="" type="checkbox"/> | <input type="checkbox"/> | <input type="checkbox"/> | <input checked="" type="checkbox"/> | <input type="checkbox"/> | <input type="checkbox"/> | <input checked="" type="checkbox"/> | <input type="checkbox"/> | <input type="checkbox"/> |  |

### 2.11. Digital IO Function Test

Procedure:

- Step1. Use SDK to set DIO high/low output.
- Step2. Use meter to measure DIO output value.

Test result:

| No. | Test item                                      | Result                              |                          |                          | Remark            |
|-----|------------------------------------------------|-------------------------------------|--------------------------|--------------------------|-------------------|
|     |                                                | Pass                                | Fail                     | N/A                      |                   |
| 1   | DIO ports should be controlled correct by SDK. | <input checked="" type="checkbox"/> | <input type="checkbox"/> | <input type="checkbox"/> | BIOS control pass |

### 2.12. TPM2.0 Function Test

Procedure:

- Step1. Enable BIOS\TPM device and status.
- Step2. `$ wget https://drive.google.com/open?id=0B2qBRy2H60mEaF9NTG5tWWVIRzA<#get eltt2 >`
- Step3. `$ unzip ELTT2_v1.0_Released.zip.`
- Step4. `$ dmesg | grep -i tpm`  
<#to check if tpm module has been loaded during boot process>
- Step5. Do the following command to rebuild the tool:
  - a. `$ cd ./eltt2/eltt2/`
  - b. `$ make clean`
  - c. `$ make`
- Step6. `$ sudo ./eltt2 -g`  
#to read the tpm information:
- Step7. `$ ls /dev/tpm*`  
# check if the tpm device has been included in the system devices
- Step8. `$ sudo ./eltt2 -a 61`  
# encrypt ascii 61 with sha-1 algorithm

Test result:

| No. | Test item                                                     | Result                              |                          |                          | Remark |
|-----|---------------------------------------------------------------|-------------------------------------|--------------------------|--------------------------|--------|
|     |                                                               | Pass                                | Fail                     | N/A                      |        |
| 1   | TPM 2.0 information should show correct.                      | <input checked="" type="checkbox"/> | <input type="checkbox"/> | <input type="checkbox"/> |        |
| 2   | "hash value extracted from tpm response" should show correct. | <input checked="" type="checkbox"/> | <input type="checkbox"/> | <input type="checkbox"/> |        |



### 2.13. Jumper and connector Function Test

Configuration:

Procedure:

- Step1. Test power button function under BIOS and OS environment.
- Step2. Test PS/2 keyboard / mouse under BIOS and OS environment.
- Step3. Connect PWB/Reset/HDD LED/PWR LED cable to FP1, check if each function can work properly
- Step4. Set keyboard lock jumper to close and check PS/2 keyboard function.
- Step5. Set “auto power on” jumper” to enable & disable and test auto power on feature.
- Step6. Use meter to measure the CFD voltage.
- Step7. Connect IPMI module and open JP3, check if IPMI function can work properly.
- Step8. Remove AC cable and CMOS jumper set 2-3 close, check if CMOS all data will be cleaned.

Test result:

| No. | Test item                                                 | Result                                                |                                     |                          | Remark                   |  |
|-----|-----------------------------------------------------------|-------------------------------------------------------|-------------------------------------|--------------------------|--------------------------|--|
|     |                                                           | Pass                                                  | Fail                                | N/A                      |                          |  |
| 1   | Power switch                                              | System on /off under BIOS.                            | <input checked="" type="checkbox"/> | <input type="checkbox"/> | <input type="checkbox"/> |  |
|     |                                                           | System shutdown or suspend when press PWB under OS.   | <input checked="" type="checkbox"/> | <input type="checkbox"/> | <input type="checkbox"/> |  |
|     |                                                           | System force shutdown when press PWB > 4SEC under OS. | <input checked="" type="checkbox"/> | <input type="checkbox"/> | <input type="checkbox"/> |  |
| 2   | Power Button (FP1)                                        | <input checked="" type="checkbox"/>                   | <input type="checkbox"/>            | <input type="checkbox"/> |                          |  |
| 3   | System Reset (FP1)                                        | <input checked="" type="checkbox"/>                   | <input type="checkbox"/>            | <input type="checkbox"/> |                          |  |
| 4   | CASEOPEN (CN12)                                           | <input checked="" type="checkbox"/>                   | <input type="checkbox"/>            | <input type="checkbox"/> |                          |  |
| 5   | Auto power (JP1)<br>1-2 disable<br>2-3 enable             | <input checked="" type="checkbox"/>                   | <input type="checkbox"/>            | <input type="checkbox"/> |                          |  |
| 6   | Clear CMOS (CN10)<br>1-3 2-4 Normal<br>3-5 4-6 Clear CMOS | <input checked="" type="checkbox"/>                   | <input type="checkbox"/>            | <input type="checkbox"/> |                          |  |

### 3. Expansion card and Application Test

#### 3.1. PCI-Express Bear Card Test:

Procedure:

Step1. Connect PCIe bear card and boot into DOS or Windows.

Step2. Execute test command for PCIe MLW test.

Test result:

| Test Item | Result                            |                                     |                          | Remark                   |  |
|-----------|-----------------------------------|-------------------------------------|--------------------------|--------------------------|--|
|           | Pass                              | Fail                                | N/A                      |                          |  |
| Mini PCIe | 1.5V, 3.3V, reset power LED check | <input checked="" type="checkbox"/> | <input type="checkbox"/> | <input type="checkbox"/> |  |
|           | Wake# function                    | <input checked="" type="checkbox"/> | <input type="checkbox"/> | <input type="checkbox"/> |  |
|           | PCIe x1 / GEN3                    | <input checked="" type="checkbox"/> | <input type="checkbox"/> | <input type="checkbox"/> |  |

Remark: GENx by specification supported.

#### 3.2. Mini PCIe Compatibility Test:

Procedure:

Step1. Connect Mini PCIe device and boot into OS.

Step2. Test PCI-e card basic function.

OS: CentOS7 kernel: 3.10.0-693.el7.x86\_64

Test result:

| Test Item                                                                              | Result                              |                          |                          | Remark                                                                         |
|----------------------------------------------------------------------------------------|-------------------------------------|--------------------------|--------------------------|--------------------------------------------------------------------------------|
|                                                                                        | Pass                                | Fail                     | N/A                      |                                                                                |
| Function should work properly as below item                                            |                                     |                          |                          |                                                                                |
| AAEON PER-C11L Intel 82574 Gigabit LAN + USB port                                      | <input checked="" type="checkbox"/> | <input type="checkbox"/> | <input type="checkbox"/> |                                                                                |
| AAEON PER-C41C-A10 4 port RS-232                                                       | <input checked="" type="checkbox"/> | <input type="checkbox"/> | <input type="checkbox"/> |                                                                                |
| AzureWave AW-NB159H 802.11b/g/n RTL8723BE combo module                                 | <input checked="" type="checkbox"/> | <input type="checkbox"/> | <input type="checkbox"/> |                                                                                |
| AzureWave AW-CB161H 802.11a/b/g/n/ac (PCI-e Wireless+ USB Bluetooth) Realtek RTL8821AE | <input checked="" type="checkbox"/> | <input type="checkbox"/> | <input type="checkbox"/> |                                                                                |
| Bointec DPE909-AA WIFI                                                                 | <input checked="" type="checkbox"/> | <input type="checkbox"/> | <input type="checkbox"/> |                                                                                |
| Quectel UC20 3G Card (USB interface)                                                   | <input checked="" type="checkbox"/> | <input type="checkbox"/> | <input type="checkbox"/> | 1. Ping 168.95.1.1 for 1000 clcyes, loss<2 times.                              |
| Sierra Wireless AirPrime MC7304 Qualcomm 4G                                            | <input checked="" type="checkbox"/> | <input type="checkbox"/> | <input type="checkbox"/> | 2. Download 1GB file from website.<br>Tested on Mini card1 and Mini card2 slot |

#### 3.3. Expansion Card Integration Test

Procedure:

Step1. Connect devices to all of expansion slots.

Step2. Install OS.

Step3. Test expansion cards basic function.

OS: Ubuntu16.04.2 kernel: 4.4.0-62-generic x86\_64

| Test Item          | Result                                     |                                     |                          | Remark                   |  |
|--------------------|--------------------------------------------|-------------------------------------|--------------------------|--------------------------|--|
|                    | Pass                                       | Fail                                | N/A                      |                          |  |
| OS installation    | No error during OS and driver installation | <input checked="" type="checkbox"/> | <input type="checkbox"/> | <input type="checkbox"/> |  |
| Expansion function | All of expansion cards should work normal. | <input checked="" type="checkbox"/> | <input type="checkbox"/> | <input type="checkbox"/> |  |

## 4. Time Accuracy Test

### 4.1. System Clock & RTC Clock Test

Procedure:

Step1. Check RTC time deviation after 24 hrs at power on status.

Step2. Check RTC time deviation after 24 hrs at power off status.

Step3. Press power button to check system with “beep” sound.

Step4. Run watchdog timer test with last version SDK.

<#./wdt -w 0> to set Normal Reset

<#./wdt -t 10> to set time for 10sec, 60sec, 255sec

Test Result:

Under Room Temperature: 26 °C

| No. | Test item                                   | Actual |     | Result                              |                          |                          | Remark |
|-----|---------------------------------------------|--------|-----|-------------------------------------|--------------------------|--------------------------|--------|
|     |                                             |        |     | Pass                                | Fail                     | N/A                      |        |
| 1   | RTC Clock in Power On less 2 sec deviation  | 0      | Sec | <input checked="" type="checkbox"/> | <input type="checkbox"/> | <input type="checkbox"/> |        |
| 2   | RTC Clock in Power Off less 2 sec deviation | 1      | Sec | <input checked="" type="checkbox"/> | <input type="checkbox"/> | <input type="checkbox"/> |        |
| 3   | System boot on in 60 sec                    | 29.06  | Sec | <input checked="" type="checkbox"/> | <input type="checkbox"/> | <input type="checkbox"/> |        |
| 4   | Watch dog time in 10+/-10% sec              | 10.38  | Sec | <input checked="" type="checkbox"/> | <input type="checkbox"/> | <input type="checkbox"/> |        |
| 5   | Watch dog time in 60+/-10% sec              | 63.04  | Sec | <input checked="" type="checkbox"/> | <input type="checkbox"/> | <input type="checkbox"/> |        |
| 6   | Watch dog time in 255+/-10% sec             | 262.16 | sec | <input checked="" type="checkbox"/> | <input type="checkbox"/> | <input type="checkbox"/> |        |

## 5. Power Consumption Test

| Configuration |                                                  |
|---------------|--------------------------------------------------|
| CPU           | Intel® Atom™ CPU C3858 @ 2.0 GHz                 |
| Memory        | Transcend DDR4 2400 16GB SEC 546 K4A8G085WB BCRC |
| Storage       | Intel SSD530 2.5". 120GB.SATA III SSD MLC        |
| O.S           | Ubuntu16.04.2 kernel:4.4.0-62-generic x86_64     |

### 5.1. Power Consumption

| Test Equipment                                                                                        |                        |      |   |                                  |
|-------------------------------------------------------------------------------------------------------|------------------------|------|---|----------------------------------|
| Equipment                                                                                             | Programmable AC Source |      |   |                                  |
| Manufacturer                                                                                          | Chroma                 |      |   |                                  |
| Model name                                                                                            | 62012P-600-8           |      |   |                                  |
| Power Supply                                                                                          | P                      |      |   | Note                             |
| Full Loading Mode<br>Test AP: Stress Test                                                             | +100VAC<br>60Hz        | 56.2 | W | # stress –c 12 (CPU total cores) |
| Win. Idle mode: Measure the current value when system in windows mode and without running any program | +100VAC<br>60Hz        | 48.1 | W |                                  |
| S5 mode: Measure the current value when system in S5 mode of windows and without running any          | +100VAC<br>60Hz        | 2.0  | W |                                  |

### 5.2. PC Health Status

Procedure:

Step1. Use meter to measure each voltage of H/W monitor supported.

Step2. Use thermometer to measure each Temp of H/W monitor supported.

Step3. Use Tachometer to measure each FAN speed of H/W monitor supported.

Test Result:

| H/W monitor                                  | Result                              |                          |                          | BIOS     | Actual  | Note |
|----------------------------------------------|-------------------------------------|--------------------------|--------------------------|----------|---------|------|
|                                              | Pass                                | Fail                     | N/A                      |          |         |      |
| (+) Vcore<br>Actual and monitor must be ±5%  | <input checked="" type="checkbox"/> | <input type="checkbox"/> | <input type="checkbox"/> | 0.996 V  | 0.98 V  |      |
| (+) VMEM<br>Actual and monitor must be ±5%   | <input checked="" type="checkbox"/> | <input type="checkbox"/> | <input type="checkbox"/> | 1.212 V  | 1.18 V  |      |
| (+) 12V<br>Actual and monitor must be ±5%    | <input checked="" type="checkbox"/> | <input type="checkbox"/> | <input type="checkbox"/> | 12.332 V | 12.30 V |      |
| (+) 5V<br>Actual and monitor must be ±5%     | <input checked="" type="checkbox"/> | <input type="checkbox"/> | <input type="checkbox"/> | 4.974 V  | 4.90 V  |      |
| (+) 3.3V<br>Actual and monitor must be ±5%   | <input checked="" type="checkbox"/> | <input type="checkbox"/> | <input type="checkbox"/> | 3.312 V  | 3.30 V  |      |
| (+) 5VDual<br>Actual and monitor must be ±5% | <input checked="" type="checkbox"/> | <input type="checkbox"/> | <input type="checkbox"/> | 4.896 V  | 4.90 V  |      |
| 3VSB<br>Actual and monitor must be ±5%       | <input checked="" type="checkbox"/> | <input type="checkbox"/> | <input type="checkbox"/> | 3.328 V  | 3.28 V  |      |
| VBAT<br>Actual and monitor must be ±5%       | <input checked="" type="checkbox"/> | <input type="checkbox"/> | <input type="checkbox"/> | 3.048 V  | 3.04 V  |      |

|                                                     |                                     |                          |                          |      |     |      |     |  |
|-----------------------------------------------------|-------------------------------------|--------------------------|--------------------------|------|-----|------|-----|--|
| CPU Fan Speed<br>Actual and monitor must be ±10%    | <input checked="" type="checkbox"/> | <input type="checkbox"/> | <input type="checkbox"/> | 5003 | rpm | 5037 | rpm |  |
| System Fan Speed<br>Actual and monitor must be ±10% | <input checked="" type="checkbox"/> | <input type="checkbox"/> | <input type="checkbox"/> | NA   | rpm | NA   | rpm |  |
| CPU DTS Temp<br>Actual and monitor must be ±15°C    | <input checked="" type="checkbox"/> | <input type="checkbox"/> | <input type="checkbox"/> | 30   | °C  | 29   | °C  |  |
| CPU Temp<br>Actual and monitor must be ±15°C        | <input checked="" type="checkbox"/> | <input type="checkbox"/> | <input type="checkbox"/> | 29   | °C  | 29   | °C  |  |
| System Temp<br>Actual and monitor must be ±5°C      | <input checked="" type="checkbox"/> | <input type="checkbox"/> | <input type="checkbox"/> | 30   | °C  | 29   | °C  |  |

### 5.3. CMOS Battery Test

Procedure:

Step1. DUT AC loss, use meter to measure voltage of CMOS battery

Step2. Use ammeter to measure current of CMOS battery.

Test Result:

(Calculate result=225mAh/measured current / 365days/24hours)

| Check item                                                                                | Measured Voltage |   | Measured Current |    | Calculate Result |       | Result                              |                          |                          | Note |
|-------------------------------------------------------------------------------------------|------------------|---|------------------|----|------------------|-------|-------------------------------------|--------------------------|--------------------------|------|
|                                                                                           |                  |   |                  |    |                  |       | Pass                                | Fail                     | N/A                      |      |
| Battery leakage<br>1. Voltage should be >3V.<br>2. Calculated result should be > 5 years. | 3.02             | V | 4.2              | uA | 6.1              | years | <input checked="" type="checkbox"/> | <input type="checkbox"/> | <input type="checkbox"/> |      |

## 6. O.S Compatibility Test

### 6.1. Linux OS Compatibility Test

Procedure:

Step1. Install Linux x86 & x64 serial from USB DVD ROM.

Step2. Install all required driver to system.

Step3. Execute the following command to test LAN basic control.

Step 5.1 Force speed

- (1) Execute command “ethtool –s ethx speed 1000 duplex full” ,link cable to confirm speed light is orange
- (2) Execute command “ethtool –s ethx speed 100 duplex full” ,link cable to confirm speed light is green
- (3) Execute command “ethtool –s ethx speed 10 duplex full” ,link cable to confirm speed light is blank

Step 5.2 ifconfig Ethernet

- (1) Execute command “ifdown ethx” close ethernet interface
- (2) Execute command “ifup ethx” start ethernet interface

Step 5.3 Jumbo Frame

Setting #ifconfig LAN mtu 9000

Check #ifconfig LAN (mtu will change from 1500 to 9000)

Step 6 Enter ping Google command (ping 8.8.8.8) or HOST PC, test networks function are whether normal

Step.7 Test USB R/W, check USB ports function.

Step.8 Execute “minicom” to test COM ports function.

Step 9 Execute command “init 0” or “shutdown –h” to shutdown system.

Step 10 Execute command “init 6” or “reboot” to reset system.

Step 11 Execute command “systemctl suspend –i” to suspend system.

Test result:

6.1.1 CentOS7 kernel:3.10.0-693.el7.x86\_64

| Test Item                                               |                                                                                                        | Result                              |                          |                          | Note |
|---------------------------------------------------------|--------------------------------------------------------------------------------------------------------|-------------------------------------|--------------------------|--------------------------|------|
|                                                         |                                                                                                        | Pass                                | Fail                     | N/A                      |      |
| System should not any error during install process.     |                                                                                                        | <input checked="" type="checkbox"/> | <input type="checkbox"/> | <input type="checkbox"/> |      |
| System should not error during LAN driver installation. |                                                                                                        | <input checked="" type="checkbox"/> | <input type="checkbox"/> | <input type="checkbox"/> |      |
| Force speed                                             | LAN connection speed should show 1000Mb when execute command “ ethtool –s ethx speed 1000 duplex full” | <input checked="" type="checkbox"/> | <input type="checkbox"/> | <input type="checkbox"/> |      |
|                                                         | LAN connection speed should show 100Mb when execute command “ ethtool –s ethx speed 100 duplex full”   | <input checked="" type="checkbox"/> | <input type="checkbox"/> | <input type="checkbox"/> |      |
|                                                         | LAN connection speed should show 10Mb when execute command “ ethtool –s ethx speed 10 duplex full”     | <input checked="" type="checkbox"/> | <input type="checkbox"/> | <input type="checkbox"/> |      |
| Ifconfig                                                | Ethernet interface should be closed when execute command “ifdown ethx”                                 | <input checked="" type="checkbox"/> | <input type="checkbox"/> | <input type="checkbox"/> |      |
|                                                         | Ethernet interface should be started when execute command “ifup ethx”                                  | <input checked="" type="checkbox"/> | <input type="checkbox"/> | <input type="checkbox"/> |      |
| Jumbo                                                   | Jumbo function should work properly                                                                    | <input checked="" type="checkbox"/> | <input type="checkbox"/> | <input type="checkbox"/> |      |

|                                                                                 |                                                                                                                         |                                     |                          |                          |                                         |
|---------------------------------------------------------------------------------|-------------------------------------------------------------------------------------------------------------------------|-------------------------------------|--------------------------|--------------------------|-----------------------------------------|
| Connected internet and ping the website should work properly. (Google: 8.8.8.8) | Onboard port1~6                                                                                                         | <input checked="" type="checkbox"/> | <input type="checkbox"/> | <input type="checkbox"/> |                                         |
|                                                                                 | 1G NIM module: port 1~8 <NIM-S13B>                                                                                      | <input checked="" type="checkbox"/> | <input type="checkbox"/> | <input type="checkbox"/> |                                         |
| USB2.0 /3.0 function should work properly                                       |                                                                                                                         | <input checked="" type="checkbox"/> | <input type="checkbox"/> | <input type="checkbox"/> |                                         |
| COM ports function should work properly.                                        |                                                                                                                         | <input checked="" type="checkbox"/> | <input type="checkbox"/> | <input type="checkbox"/> |                                         |
| Shutdown                                                                        | System should be shutdown when execute command "init 0"                                                                 | <input checked="" type="checkbox"/> | <input type="checkbox"/> | <input type="checkbox"/> |                                         |
| Reboot                                                                          | System should be reset when execute command "init 6"                                                                    | <input checked="" type="checkbox"/> | <input type="checkbox"/> | <input type="checkbox"/> |                                         |
| suspend                                                                         | 1. System should be suspend when execute command "systemctl suspend -l".<br>2. Resume from suspend should work properly | <input checked="" type="checkbox"/> | <input type="checkbox"/> | <input type="checkbox"/> | Kernel need to support graphics drvier. |

6.1.2 Ubuntu16.04.2 kernel:4.4.0-62-generic x86\_64

| Test Item                                                                       | Result                                                                                                |                                     |                          | Note                     |                    |
|---------------------------------------------------------------------------------|-------------------------------------------------------------------------------------------------------|-------------------------------------|--------------------------|--------------------------|--------------------|
|                                                                                 | Pass                                                                                                  | Fail                                | N/A                      |                          |                    |
| System should not any error during install process.                             |                                                                                                       | <input checked="" type="checkbox"/> | <input type="checkbox"/> | <input type="checkbox"/> |                    |
| System should not error during LAN driver installation.                         |                                                                                                       | <input checked="" type="checkbox"/> | <input type="checkbox"/> | <input type="checkbox"/> | ixgbe-5.1.3.tar.gz |
| Force speed                                                                     | LAN connection speed should show 1000Mb when execute command "ethtool -s ethx speed 1000 duplex full" | <input checked="" type="checkbox"/> | <input type="checkbox"/> | <input type="checkbox"/> |                    |
|                                                                                 | LAN connection speed should show 100Mb when execute command "ethtool -s ethx speed 100 duplex full"   | <input checked="" type="checkbox"/> | <input type="checkbox"/> | <input type="checkbox"/> |                    |
|                                                                                 | LAN connection speed should show 10Mb when execute command "ethtool -s ethx speed 10 duplex full"     | <input checked="" type="checkbox"/> | <input type="checkbox"/> | <input type="checkbox"/> |                    |
| Ifconfig                                                                        | Ethernet interface should be closed when execute command "'ifconfig ethx down"                        | <input checked="" type="checkbox"/> | <input type="checkbox"/> | <input type="checkbox"/> |                    |
|                                                                                 | Ethernet interface should be started when execute command "'ifconfig ethx up"                         | <input checked="" type="checkbox"/> | <input type="checkbox"/> | <input type="checkbox"/> |                    |
| Jumbo                                                                           | Jumbo function should work properly                                                                   | <input checked="" type="checkbox"/> | <input type="checkbox"/> | <input type="checkbox"/> |                    |
| Connected internet and ping the website should work properly. (Google: 8.8.8.8) | Onboard port1~6                                                                                       | <input checked="" type="checkbox"/> | <input type="checkbox"/> | <input type="checkbox"/> |                    |
|                                                                                 | NIM module: port 1~8 <NIM-C13B>                                                                       | <input checked="" type="checkbox"/> | <input type="checkbox"/> | <input type="checkbox"/> |                    |
| USB2.0 / 3.0 function should work properly                                      |                                                                                                       | <input checked="" type="checkbox"/> | <input type="checkbox"/> | <input type="checkbox"/> |                    |
| COM ports function should work properly.                                        |                                                                                                       | <input checked="" type="checkbox"/> | <input type="checkbox"/> | <input type="checkbox"/> |                    |
| Shutdown                                                                        | System should be shutdown when execute command "init 0"                                               | <input checked="" type="checkbox"/> | <input type="checkbox"/> | <input type="checkbox"/> |                    |
| Reboot                                                                          | System should be reset when execute command "init 6"                                                  | <input checked="" type="checkbox"/> | <input type="checkbox"/> | <input type="checkbox"/> |                    |

## 6.2. Windows OS Compatibility Test

Procedure:

- Step1. Install Windows OS from USB DVD ROM.
- Step2. Install all required driver to system.
- Step3. Connect internet, check each LAN port function.
- Step4. Insert USB flash, check each USB port function.
- Step5. ACPI S5 and reset function test.
- Step6. ACPI S3 and S4 function test if support graphics driver.

Test result:

### 6.2.1 Windows 10 Enterprise 64bit English version

| Test Item                                                                          | Result                                               |                                     |                          | Note                                |  |
|------------------------------------------------------------------------------------|------------------------------------------------------|-------------------------------------|--------------------------|-------------------------------------|--|
|                                                                                    | Pass                                                 | Fail                                | N/A                      |                                     |  |
| System should not any error during install process.                                | <input checked="" type="checkbox"/>                  | <input type="checkbox"/>            | <input type="checkbox"/> | UEFI mode                           |  |
| All required driver should be installed.                                           | <input checked="" type="checkbox"/>                  | <input type="checkbox"/>            | <input type="checkbox"/> |                                     |  |
| Connected internet and ping the website should work properly.<br>(Google: 8.8.8.8) | Onboard port1~6                                      | <input checked="" type="checkbox"/> | <input type="checkbox"/> | <input type="checkbox"/>            |  |
|                                                                                    | NIM module: port 1~8<br><NIM-S13B>                   | <input type="checkbox"/>            | <input type="checkbox"/> | <input checked="" type="checkbox"/> |  |
| USB ports should work properly and speed should meet specification.                | <input checked="" type="checkbox"/>                  | <input type="checkbox"/>            | <input type="checkbox"/> |                                     |  |
| Monitor should display normal and should detect monitor EDID.                      | VGA                                                  | <input checked="" type="checkbox"/> | <input type="checkbox"/> | <input type="checkbox"/>            |  |
| Transmission should work properly.<br>Baud rate: 115200bps                         | Console                                              | <input checked="" type="checkbox"/> | <input type="checkbox"/> | <input type="checkbox"/>            |  |
|                                                                                    | COM1                                                 | <input checked="" type="checkbox"/> | <input type="checkbox"/> | <input type="checkbox"/>            |  |
| Shutdown                                                                           | System should be shutdown when click "shutdown" icon | <input checked="" type="checkbox"/> | <input type="checkbox"/> | <input type="checkbox"/>            |  |
| Reboot                                                                             | System should be reset when click "Reset" icon.      | <input checked="" type="checkbox"/> | <input type="checkbox"/> | <input type="checkbox"/>            |  |



## 7. BIOS Function Test

Procedure:

- Step1. Flash BIOS process will complete and run correctly
- Step2. Press Keyboard “ DEL ” Key into BIOS.
- Step3. To ensure the BIOS setting can be controlled correctly.
- Step4. Please add or del test item from your test BIOS Version.

Test Result:

### 7.1. Flash BIOS

| Test Item<br>(Following item should work properly) | Result                              |                          |                          | Note |
|----------------------------------------------------|-------------------------------------|--------------------------|--------------------------|------|
|                                                    | Pass                                | Fail                     | N/A                      |      |
| *Execute Go.bat for flash BIOS                     | <input checked="" type="checkbox"/> | <input type="checkbox"/> | <input type="checkbox"/> |      |
| *Press keyboard Del into BIOS setup                | <input checked="" type="checkbox"/> | <input type="checkbox"/> | <input type="checkbox"/> |      |

### 7.2. Advanced Test

| Test Item<br>(Following item should work properly) | Result                              |                                     |                                     | Note                                                                          |                  |
|----------------------------------------------------|-------------------------------------|-------------------------------------|-------------------------------------|-------------------------------------------------------------------------------|------------------|
|                                                    | Pass                                | Fail                                | N/A                                 |                                                                               |                  |
| Case Open Warning                                  | <input checked="" type="checkbox"/> | <input type="checkbox"/>            | <input type="checkbox"/>            |                                                                               |                  |
| Trusted Computing                                  | TPM Device Configuration            | <input checked="" type="checkbox"/> | <input type="checkbox"/>            | TPM 2.0                                                                       |                  |
|                                                    | TPM Device Support                  | <input checked="" type="checkbox"/> | <input type="checkbox"/>            | Enable / Disabled                                                             |                  |
|                                                    | Device Selectt                      | <input checked="" type="checkbox"/> | <input type="checkbox"/>            |                                                                               |                  |
| Serial port console redirection                    | console redirection                 | <input checked="" type="checkbox"/> | <input type="checkbox"/>            | Enable / Disabled                                                             |                  |
|                                                    | Baud rate: 9600/38400/115200        | <input checked="" type="checkbox"/> | <input type="checkbox"/>            |                                                                               |                  |
| USB Configuration                                  | Legacy USB Support                  | <input checked="" type="checkbox"/> | <input type="checkbox"/>            | Enable / Disabled                                                             |                  |
| SIO Configuration                                  | Serial port                         | <input checked="" type="checkbox"/> | <input type="checkbox"/>            |                                                                               |                  |
| HW Monitor                                         | Temp                                | <input checked="" type="checkbox"/> | <input type="checkbox"/>            |                                                                               |                  |
|                                                    | Fan Speed                           | <input checked="" type="checkbox"/> | <input type="checkbox"/>            |                                                                               |                  |
|                                                    | voltage Value                       | <input checked="" type="checkbox"/> | <input type="checkbox"/>            |                                                                               |                  |
| LAN Bypass Config                                  | Status LED                          | <input checked="" type="checkbox"/> | <input type="checkbox"/>            | LED off/RED on/RED Blink/RED Fast Blink/Green on/Green Blink/Green Fast blink |                  |
|                                                    | LAN kit1                            | Power on                            | <input checked="" type="checkbox"/> | <input type="checkbox"/>                                                      | PassTru / Bypass |
|                                                    |                                     | Power off                           | <input checked="" type="checkbox"/> | <input type="checkbox"/>                                                      | PassTru / Bypass |
|                                                    | LAN kit2                            | Power on                            | <input checked="" type="checkbox"/> | <input type="checkbox"/>                                                      | PassTru / Bypass |
|                                                    |                                     | Power off                           | <input checked="" type="checkbox"/> | <input type="checkbox"/>                                                      | PassTru / Bypass |
|                                                    | WDT                                 | System Reset                        | <input checked="" type="checkbox"/> | <input type="checkbox"/>                                                      |                  |
| Force Bypass                                       |                                     | <input checked="" type="checkbox"/> | <input type="checkbox"/>            |                                                                               |                  |
| Power manager                                      | Power Mode                          | AT                                  | <input checked="" type="checkbox"/> | <input type="checkbox"/>                                                      |                  |
|                                                    |                                     | ATX                                 | <input checked="" type="checkbox"/> | <input type="checkbox"/>                                                      |                  |
|                                                    | AC power loss                       | Power on                            | <input checked="" type="checkbox"/> | <input type="checkbox"/>                                                      |                  |
|                                                    |                                     | Power off                           | <input checked="" type="checkbox"/> | <input type="checkbox"/>                                                      |                  |
|                                                    |                                     | Last state                          | <input checked="" type="checkbox"/> | <input type="checkbox"/>                                                      |                  |
|                                                    | RTC wake system from S5             | Fixed Time                          | <input checked="" type="checkbox"/> | <input type="checkbox"/>                                                      |                  |
| Dynamic Time                                       |                                     | <input checked="" type="checkbox"/> | <input type="checkbox"/>            |                                                                               |                  |

### 7.3. Chipset Test

| Test Item<br>(Following item should work properly) |                         | Result                              |                          |                          | Note |
|----------------------------------------------------|-------------------------|-------------------------------------|--------------------------|--------------------------|------|
|                                                    |                         | Pass                                | Fail                     | N/A                      |      |
| Intel RC Setup                                     | Processor Configuration | <input checked="" type="checkbox"/> | <input type="checkbox"/> | <input type="checkbox"/> |      |
|                                                    | ME Configuration        | <input checked="" type="checkbox"/> | <input type="checkbox"/> | <input type="checkbox"/> |      |
|                                                    | Memory Information      | <input checked="" type="checkbox"/> | <input type="checkbox"/> | <input type="checkbox"/> |      |
|                                                    | SATA Port               | <input checked="" type="checkbox"/> | <input type="checkbox"/> | <input type="checkbox"/> |      |

### 7.4. Boot Test

| Test Item<br>(Following item should work properly) |  | Result                              |                          |                          | Note            |
|----------------------------------------------------|--|-------------------------------------|--------------------------|--------------------------|-----------------|
|                                                    |  | Pass                                | Fail                     | N/A                      |                 |
| Quiet Boot                                         |  | <input checked="" type="checkbox"/> | <input type="checkbox"/> | <input type="checkbox"/> |                 |
| Launch PXE ROM                                     |  | <input checked="" type="checkbox"/> | <input type="checkbox"/> | <input type="checkbox"/> | Support LAN1 /2 |
| Boot From Hard Disk                                |  | <input checked="" type="checkbox"/> | <input type="checkbox"/> | <input type="checkbox"/> |                 |
| Boot From USB HDD                                  |  | <input checked="" type="checkbox"/> | <input type="checkbox"/> | <input type="checkbox"/> |                 |
| Boot From USB CD-ROM                               |  | <input checked="" type="checkbox"/> | <input type="checkbox"/> | <input type="checkbox"/> |                 |
| Boot from LAN                                      |  | <input checked="" type="checkbox"/> | <input type="checkbox"/> | <input type="checkbox"/> |                 |
| Disable                                            |  | <input checked="" type="checkbox"/> | <input type="checkbox"/> | <input type="checkbox"/> |                 |

### 7.5. Clear CMOS and Load Default Test

| Test Item<br>(Following item should work properly) |                                                                | Result                              |                          |                          | Note                                |
|----------------------------------------------------|----------------------------------------------------------------|-------------------------------------|--------------------------|--------------------------|-------------------------------------|
|                                                    |                                                                | Pass                                | Fail                     | N/A                      |                                     |
| Clear CMOS by jumper (under G3 status)             |                                                                | <input checked="" type="checkbox"/> | <input type="checkbox"/> | <input type="checkbox"/> | Clear date, time, setting, password |
| Clear CMOS by remove battery (under G3 status)     |                                                                | <input checked="" type="checkbox"/> | <input type="checkbox"/> | <input type="checkbox"/> | Clear date, time, setting, password |
| Load default                                       | Date, time, password should be kept                            | <input checked="" type="checkbox"/> | <input type="checkbox"/> | <input type="checkbox"/> |                                     |
|                                                    | BIOS setting should be restored to default.                    | <input checked="" type="checkbox"/> | <input type="checkbox"/> | <input type="checkbox"/> |                                     |
|                                                    | Boot option priorities should restore from disable to default. | <input checked="" type="checkbox"/> | <input type="checkbox"/> | <input type="checkbox"/> |                                     |

### 7.6. AAEON Tag Check Utility

| Test Item<br>(Following item should work properly) |  | Result                              |                          |                          | Note    |
|----------------------------------------------------|--|-------------------------------------|--------------------------|--------------------------|---------|
|                                                    |  | Pass                                | Fail                     | N/A                      |         |
| Check AAEON BIOS OK                                |  | <input checked="" type="checkbox"/> | <input type="checkbox"/> | <input type="checkbox"/> | Cks.nsh |

### 7.7. Supervisor / User Password Test

| Test Item<br>(Following item should work properly) |  | Result                              |                          |                          | Note |
|----------------------------------------------------|--|-------------------------------------|--------------------------|--------------------------|------|
|                                                    |  | Pass                                | Fail                     | N/A                      |      |
| Administrator Password                             |  | <input checked="" type="checkbox"/> | <input type="checkbox"/> | <input type="checkbox"/> |      |
| User Password                                      |  | <input checked="" type="checkbox"/> | <input type="checkbox"/> | <input type="checkbox"/> |      |

## 7.8. Negative Test

### 7.8.1 USB Keyboard Negative Test

| Methods                                                                                                                         | Result                              |                          |                          | Note |
|---------------------------------------------------------------------------------------------------------------------------------|-------------------------------------|--------------------------|--------------------------|------|
|                                                                                                                                 | Pass                                | Fail                     | N/A                      |      |
| 1. Boot into BIOS setup manual.<br>2. Press NumLock or ScrLk and press arrow key.<br>3. confirm arrow key function are normally | <input checked="" type="checkbox"/> | <input type="checkbox"/> | <input type="checkbox"/> |      |

### 7.8.2 UEFI Mode Negative Test

| Methods                                                                                                                                                        | Result                              |                          |                          | Note |
|----------------------------------------------------------------------------------------------------------------------------------------------------------------|-------------------------------------|--------------------------|--------------------------|------|
|                                                                                                                                                                | Pass                                | Fail                     | N/A                      |      |
| 1. Install Windows with UEFI mode.<br>2. Clear CMOS.<br>3. Confirm BIOS\Boot device was not loss "Windows boot manager" and should boot into Windows properly. | <input checked="" type="checkbox"/> | <input type="checkbox"/> | <input type="checkbox"/> |      |

## 8. Stability Test

### 8.1. Run in Test

Configuration:

CPU: Intel® Atom™ CPU C3858 @ 2.0 GHz  
 RAM: Transcend DDR4 2400 16GB SEC 546 K4A8G085WB BCRC  
 Storage: onboard eMMC 16GB  
 Graphics: PCI-E x1 VGA card  
 OS: Ubuntu16.04.2 kernel:4.4.0-62-generic x86\_64  
 CentOS7 kernel:3.10.0-693.el7.x86\_64

Procedure:

Step1. Install test AP : Burnintest Linux V3.3.  
 Step2. Select test item: CPU, RAM, COM, 2D, 3D, Disk, Network / loading select 100%.

Test Result:

| Test Item                                                                                                            | Result               |                                     |                                     | Note                                |                                     |                     |
|----------------------------------------------------------------------------------------------------------------------|----------------------|-------------------------------------|-------------------------------------|-------------------------------------|-------------------------------------|---------------------|
|                                                                                                                      | Pass                 | Fail                                | N/A                                 |                                     |                                     |                     |
| Burn In Test Linux V3.3<br>Duty: 100<br>Time: over 12 hours<br><br><System should not error or hang during testing.> | CPU                  | <input checked="" type="checkbox"/> | <input type="checkbox"/>            | <input type="checkbox"/>            |                                     |                     |
|                                                                                                                      | RAM                  | <input checked="" type="checkbox"/> | <input type="checkbox"/>            | <input type="checkbox"/>            |                                     |                     |
|                                                                                                                      | COM                  | <input checked="" type="checkbox"/> | <input type="checkbox"/>            | <input type="checkbox"/>            | ttyS0                               |                     |
|                                                                                                                      | 2D                   | <input checked="" type="checkbox"/> | <input type="checkbox"/>            | <input type="checkbox"/>            |                                     |                     |
|                                                                                                                      | 3D                   | <input type="checkbox"/>            | <input type="checkbox"/>            | <input checked="" type="checkbox"/> |                                     |                     |
|                                                                                                                      | Disk                 | SATA                                | <input checked="" type="checkbox"/> | <input type="checkbox"/>            | <input type="checkbox"/>            |                     |
|                                                                                                                      |                      | CF                                  | <input type="checkbox"/>            | <input type="checkbox"/>            | <input checked="" type="checkbox"/> |                     |
|                                                                                                                      |                      | CFast (option)                      | <input type="checkbox"/>            | <input type="checkbox"/>            | <input checked="" type="checkbox"/> | CFast colay with CF |
|                                                                                                                      | Sound                | <input type="checkbox"/>            | <input type="checkbox"/>            | <input checked="" type="checkbox"/> |                                     |                     |
|                                                                                                                      | Network<br><default> | <input checked="" type="checkbox"/> | <input type="checkbox"/>            | <input type="checkbox"/>            |                                     |                     |

Note: COM PORT Speed Set [cycle to 115200].

### 8.2. Cold Boot Test

#### 8.2.1 ACPI G3 Cold Boot Test

Configuration:

CPU: Intel® Atom™ CPU C3858 @ 2.0 GHz  
 RAM: Transcend DDR4 2400 16GB SEC 546 K4A8G085WB BCRC  
 Storage: Transcend USB3.0 Flash 8GB  
 Graphics: Onboard Graphics  
 OS: UEFI

Procedure:

Step1. Set auto power on jumper for enable or set BIOS\restore AC loss for always on.  
 Step2. Set power on with 90 second and power off with 20 second.  
 Step3. Run the on/off test over 1000 cycles to test system boot up stability at room temp.  
 Step4. Set H/W auto power on.  
 Step5. Set power on with 60 second and power off with 5 second.  
 Step6. Run the on/off test over 20 cycles to test system AC power restored in short time

Test Result:

| Test item                                                                                                          | Result                              |                          |                          | Note                                                                                                                 |
|--------------------------------------------------------------------------------------------------------------------|-------------------------------------|--------------------------|--------------------------|----------------------------------------------------------------------------------------------------------------------|
|                                                                                                                    | Pass                                | Fail                     | N/A                      |                                                                                                                      |
| AC loss cold boot over 1000 cycles<br><loss rate: 0 /1000 times>                                                   | <input checked="" type="checkbox"/> | <input type="checkbox"/> | <input type="checkbox"/> | <input type="checkbox"/> Jumper set auto power button<br><input checked="" type="checkbox"/> BIOS select " power on" |
| G3(AC loss) cold boot over 20 cycles<br>Setting: Power on- 60sec ;<br>Power off- 5sec.<br><loss rate: 0 /20 times> | <input checked="" type="checkbox"/> | <input type="checkbox"/> | <input type="checkbox"/> | <input checked="" type="checkbox"/> Jumper set auto power button                                                     |

8.2.2 Power Button Cold Boot Test

Configuration:

CPU: Intel® Atom™ CPU C3858 @ 2.0 GHz  
RAM: Transcend DDR4 2400 16GB SEC 546 K4A8G085WB BCRC  
Storage: Transcend USB3.0 Flash 8GB  
Graphics: Onboard Graphics  
OS: UEFI

Procedure:

- Step1. Set auto power on jumper for disable.
- Step2. Set each ON/OFF cycle with 180 second.
- Step3. Run the power button on/off test over 500 cycles to test system boot up stability at room temp.

Test Result:

| Test item                                                      | Result                              |                          |                          | Note |
|----------------------------------------------------------------|-------------------------------------|--------------------------|--------------------------|------|
|                                                                | Pass                                | Fail                     | N/A                      |      |
| Power button boot over 500 cycles<br><loss rate: 0 /500 times> | <input checked="" type="checkbox"/> | <input type="checkbox"/> | <input type="checkbox"/> |      |

8.3. Memory Test

Configuration:

OS: UEFI  
Tool: Passmark Memtest version7.0 UEFI  
Memory information: Transcend DDR4 2400 16GB (SPEC max support size).

| Test item                                                                   | Result                              |                          |                          | Note |
|-----------------------------------------------------------------------------|-------------------------------------|--------------------------|--------------------------|------|
|                                                                             | Pass                                | Fail                     | N/A                      |      |
| Memory Test for 4 loops.<br>< Memtest result should not error or<br>hang..> | <input checked="" type="checkbox"/> | <input type="checkbox"/> | <input type="checkbox"/> |      |

Remark: If system support UEFI mode only, the test tool is [Memtest86 Version 5.0 Experimental UEFI Beta]

## 9. 1G LAN Performance Test

### 9.1 DUT and Test Equipment

#### 9.1.1. DUT Specification

##### Hardware:

- Model name: FWS-7360 (NMB-7360 A0.1)
- CPU: Intel® Atom™ CPU C3858 @ 2.0 GHz
- RAM: Transcend DDR4 2400 16GB SEC 546 K4A8G085WB BCRC
- HDD: Intel SSD530 2.5". 120GB.SATA III SSD MLC

##### Software:

- BIOS: FWS-7360 R0.2 (K736AM02) (02/09/2018)
- Operating System: CentOS7 kernel:3.10.0-693.el7.x86\_64

#### 9.1.2. Test Equipments Specification

##### SPIRENT Smartbits

- Chassis: SPIRENT Smartbits 600B
- Chassis Version: 2.80.003 (Cur) 2.50.000
- Chassis Serial #: 06014047
- Library: 6.00-29
- API: 5.50.42.01
- File: 0550042
- Module: 2 \* LAN-3324A SmartMetrics XD 4-Port 10/100/1000Base-T Gigabit Ethernet
- Test Software: SmartFlow5.50.42.1

## 9.2 RFC-2544 performance test (2 port)

### 9.2.1. Throughput test (2 port)

#### Test Description:

- In DUT System, set routing function enabled.  
<# echo 1 > /proc/sys/net/ipv4/ip\_forward>
- Test Configuration as below Figure.

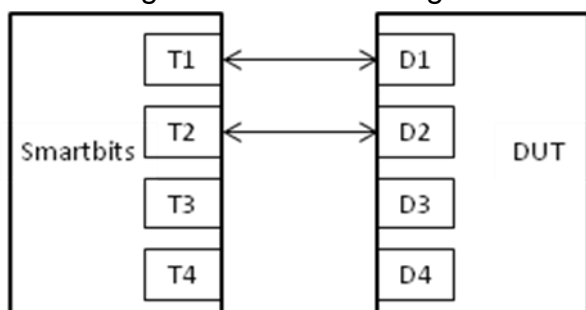

- Smartflow\Test Group to add port1<->port2 with Bi-directional,
- The tester set loading traffic from 1% to 100% and the traffic step is 50%.
- Interaction Constants Duration Time Set to 60 Sec.
- Test all LAN ports performance.

#### Test Result:

Test Group: <LAN1-LAN2 bi-directional>

| Speed:<br>1000_Full | Frame Size(bytes) |            |           |     |      |      |      |
|---------------------|-------------------|------------|-----------|-----|------|------|------|
| LAN ports           | 64                | 128        | 256       | 512 | 1024 | 1280 | 1518 |
| 1-2                 | 24.9765625        | 43.5390625 | 76.796875 | 100 | 100  | 100  | 100  |
| 3-4                 | 23.4296875        | 41.21875   | 73.703125 | 100 | 100  | 100  | 100  |
| 5-6                 | 44.3125           | 77.5703125 | 100       | 100 | 100  | 100  | 100  |
| 7-8                 | 44.3125           | 77.5703125 | 100       | 100 | 100  | 100  | 100  |

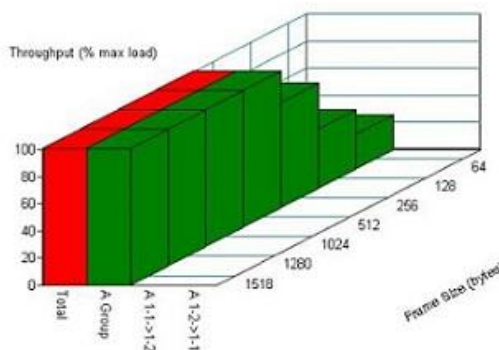

Throughput vs Frame Size

| Name/Frame size | 64         | 128        | 256       | 512 | 1024 | 1280 | 1518 |
|-----------------|------------|------------|-----------|-----|------|------|------|
| Total           | 24.9765625 | 43.5390625 | 76.796875 | 100 | 100  | 100  | 100  |
| A Group         | 24.9765625 | 43.5390625 | 76.796875 | 100 | 100  | 100  | 100  |
| A 1-1->1-2      | N/A        | N/A        | N/A       | N/A | N/A  | N/A  | N/A  |
| A 1-2->1-1      | N/A        | N/A        | N/A       | N/A | N/A  | N/A  | N/A  |

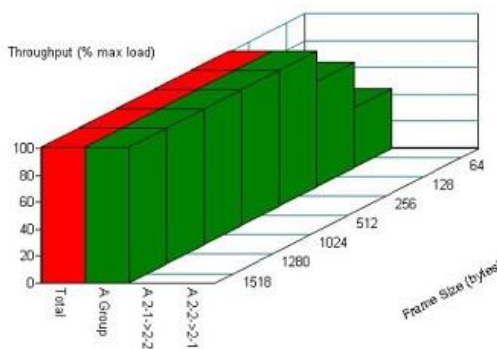

Throughput vs Frame Size

| Name/Frame size | 64      | 128        | 256 | 512 | 1024 | 1280 | 1518 |
|-----------------|---------|------------|-----|-----|------|------|------|
| Total           | 44.3125 | 77.5703125 | 100 | 100 | 100  | 100  | 100  |
| A Group         | 44.3125 | 77.5703125 | 100 | 100 | 100  | 100  | 100  |
| A 2-1->2-2      | N/A     | N/A        | N/A | N/A | N/A  | N/A  | N/A  |
| A 2-2->2-1      | N/A     | N/A        | N/A | N/A | N/A  | N/A  | N/A  |

### 9.3 RFC-2544 performance test (8 ports)

#### 9.3.1. Throughput test

##### Test Description:

1. In DUT System, set routing function enabled.  
<# echo 1 > /proc/sys/net/ipv4/ip\_forward>
2. Test Configuration as below Figure.

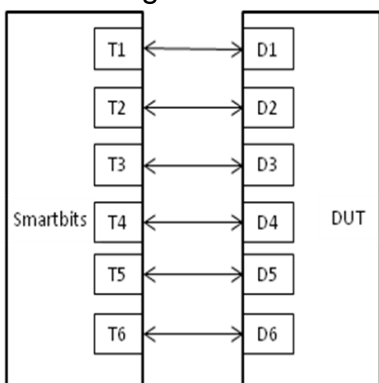

3. Smartflow\Test Group to add port1<->port2 with Bi-directional, port3<->port4 with Bi-directional, port5<->port6 with Bi-directional, port7<->port8 with Bi-directional.
4. The tester set loading traffic from 1% to 100% and the traffic step is 50%.
5. Interaction Constants Duration Time Set to 60 Sec.
6. Test all LAN ports performance.

##### Test Result:

Test Group: <LAN1-LAN2 bi-directional> ; <LAN3-LAN4 bi-directional>  
<LAN5-LAN6 bi-directional> ; <LAN7-LAN8 bi-directional>

| Speed:<br>1000_Full | Frame Size(bytes) |          |            |      |      |      |      |
|---------------------|-------------------|----------|------------|------|------|------|------|
| LAN ports           | 64                | 128      | 256        | 512  | 1024 | 1280 | 1518 |
| 1 ~8                | 8.734375          | 16.46875 | 29.6171875 | 50.5 | 100  | 100  | 100  |



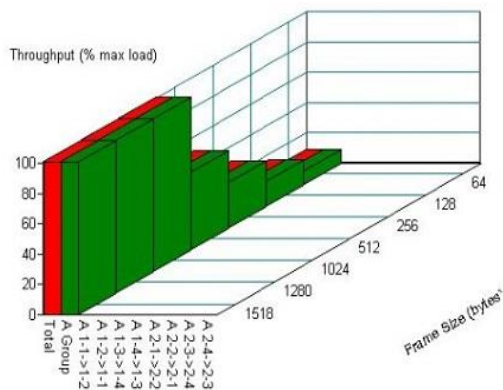

Throughput vs Frame Size

| Name/FrameSize | 64       | 128      | 256        | 512  | 1024 | 1280 | 1518 |
|----------------|----------|----------|------------|------|------|------|------|
| Total          | 8.734375 | 16.46875 | 29.6171875 | 50.5 | 100  | 100  | 100  |
| A Group        | 8.734375 | 16.46875 | 29.6171875 | 50.5 | 100  | 100  | 100  |
| A 1-1->1-2     | N/A      | N/A      | N/A        | N/A  | N/A  | N/A  | N/A  |
| A 1-2->1-1     | N/A      | N/A      | N/A        | N/A  | N/A  | N/A  | N/A  |
| A 1-3->1-4     | N/A      | N/A      | N/A        | N/A  | N/A  | N/A  | N/A  |
| A 1-4->1-3     | N/A      | N/A      | N/A        | N/A  | N/A  | N/A  | N/A  |
| A 2-1->2-2     | N/A      | N/A      | N/A        | N/A  | N/A  | N/A  | N/A  |
| A 2-2->2-1     | N/A      | N/A      | N/A        | N/A  | N/A  | N/A  | N/A  |
| A 2-3->2-4     | N/A      | N/A      | N/A        | N/A  | N/A  | N/A  | N/A  |
| A 2-4->2-3     | N/A      | N/A      | N/A        | N/A  | N/A  | N/A  | N/A  |

### 9.4 LAN Endurance Test

#### Configuration:

CPU: Intel® Atom™ CPU C3858 @ 2.0 GHz

RAM: Transcend DDR4 2400 16GB SEC 546 K4A8G085WB BCRC

HDD: Intel SSD530 2.5". 120GB.SATA III SSD MLC

#### Software:

BIOS: FWS-7360 R0.2 (K736AM02) (02/09/2018)

Operating System: CentOS7 kernel: 3.10.0-693.el7.x86\_64

#### Procedure:

Step1. Use SmartBits to test LAN endurance.

Step2. Test Group:

<LAN1-LAN2 bi-directional> ; <LAN3-LAN4 bi-directional>

<LAN5-LAN6 bi-directional> ; <LAN7-LAN8 bi-directional>

Step3. To set Frame size=1518 / loading=100 / time=43200sec

#### Test Result:

| Test item                                                             | Result                              |                          |                          | Note |
|-----------------------------------------------------------------------|-------------------------------------|--------------------------|--------------------------|------|
|                                                                       | Pass                                | Fail                     | N/A                      |      |
| Onboard LAN1~8 Endurance Test<br><Test result should not frame loss.> | <input checked="" type="checkbox"/> | <input type="checkbox"/> | <input type="checkbox"/> |      |

#### Throughput Detail Report

[Summary Report](#) [Stray Frames Report](#) [Port Errors Report](#) [Packet Rate Report](#)

| Name       | Time              | FrameSize | Load      | TxFrames    | RxFrames    | LostFrames | Lost (%) | Throughput | Tx fps | Tx L2 bps  | Rx fps | Rx L3 bps  | Rx L2 bps  |
|------------|-------------------|-----------|-----------|-------------|-------------|------------|----------|------------|--------|------------|--------|------------|------------|
| Total      | 03/03/18 05:57:10 | 1518      | 100.00000 | 28088425680 | 28088425680 | 0          | 0.00000  | 100.00000  | 650195 | 7999999758 | 650195 | 7802340467 | 7999999758 |
| A Group    | 03/03/18 05:57:10 | 1518      | 100.00000 | 28088425680 | 28088425680 | 0          | 0.00000  | 100.00000  | 650195 | 7999999758 | 650195 | 7802340467 | 7999999758 |
| A 1-1->1-2 | 03/03/18 05:57:10 | 1518      | 100.00000 | 3511053210  | 3511053210  | 0          | 0.00000  | N/A        | 81274  | 999999970  | 81274  | 975292558  | 999999970  |
| A 1-2->1-1 | 03/03/18 05:57:10 | 1518      | 100.00000 | 3511053210  | 3511053210  | 0          | 0.00000  | N/A        | 81274  | 999999970  | 81274  | 975292558  | 999999970  |
| A 1-3->1-4 | 03/03/18 05:57:10 | 1518      | 100.00000 | 3511053210  | 3511053210  | 0          | 0.00000  | N/A        | 81274  | 999999970  | 81274  | 975292558  | 999999970  |
| A 1-4->1-3 | 03/03/18 05:57:10 | 1518      | 100.00000 | 3511053210  | 3511053210  | 0          | 0.00000  | N/A        | 81274  | 999999970  | 81274  | 975292558  | 999999970  |
| A 2-1->2-2 | 03/03/18 05:57:10 | 1518      | 100.00000 | 3511053210  | 3511053210  | 0          | 0.00000  | N/A        | 81274  | 999999970  | 81274  | 975292558  | 999999970  |
| A 2-2->2-1 | 03/03/18 05:57:10 | 1518      | 100.00000 | 3511053210  | 3511053210  | 0          | 0.00000  | N/A        | 81274  | 999999970  | 81274  | 975292558  | 999999970  |
| A 2-3->2-4 | 03/03/18 05:57:10 | 1518      | 100.00000 | 3511053210  | 3511053210  | 0          | 0.00000  | N/A        | 81274  | 999999970  | 81274  | 975292558  | 999999970  |
| A 2-4->2-3 | 03/03/18 05:57:10 | 1518      | 100.00000 | 3511053210  | 3511053210  | 0          | 0.00000  | N/A        | 81274  | 999999970  | 81274  | 975292558  | 999999970  |