

# CE EMC TEST REPORT

for

**PCI-104 CPU Module**

**MODEL: PFM-541IWT-xxxxxx**

Test Report Number:

80627204-E

Issued to:

**AAEON Technology Inc.**

**5F, No. 135, Lane 235, Pao Chiao Rd., Hsin-Tien City,  
Taipei, Taiwan, R.O.C.**

Issued by:

**Compliance Certification Services Inc.**

**Sindian BU.**

**No.163-1, Jhongsheng Rd., Sindian City,  
Taipei County 23151, Taiwan**

**TEL: 886-2-22170894**

**FAX: 886-2-22171029**

**Issued Date: July 04, 2008**



***Note:** This report shall not be reproduced except in full, without the written approval of Compliance Certification Services Inc. This document may be altered or revised by Compliance Certification Services Inc. personnel only, and shall be noted in the revision section of the document. The client should not use it to claim product endorsement by TAF, A2LA, NVLAP, NIST or any government agencies. The test results in the report only apply to the tested sample.*



**Revision History**

Rev.	Issue Date	Revisions	Effect Page	Revised By
00		Initial Issue	ALL	



TABLE OF CONTENTS

1 TEST CERTIFICATION ..... 4

2 TEST RESULT SUMMARY ..... 5

3 EUT DESCRIPTION ..... 6

4 TEST METHODOLOGY ..... 7

    4.1. DECISION OF FINAL TEST MODE ..... 7

    4.2. EUT SYSTEM OPERATION ..... 7

5 SETUP OF EQUIPMENT UNDER TEST ..... 8

    5.1. DESCRIPTION OF SUPPORT UNITS ..... 8

    5.2. CONFIGURATION OF SYSTEM UNDER TEST ..... 9

6 FACILITIES AND ACCREDITATIONS ..... 10

    6.1. FACILITIES ..... 10

    6.2. ACCREDITATIONS ..... 10

    6.3. MEASUREMENT UNCERTAINTY ..... 10

7 EMISSION TEST ..... 11

    7.1. CONDUCTED EMISSION MEASUREMENT ..... 11

    7.2. CONDUCTED EMISSION MEASUREMENT AT TELECOMMUNICATION PORTS ..... 15

    7.3. RADIATED EMISSION MEASUREMENT ..... 19

    7.4. HARMONICS CURRENT MEASUREMENT ..... 25

    7.5. VOLTAGE FLUCTUATION AND FLICKER MEASUREMENT ..... 28

8 IMMUNITY TEST ..... 32

    8.1. GENERAL DESCRIPTION ..... 32

    8.2. GENERAL PERFORMANCE CRITERIA DESCRIPTION ..... 33

    8.3. ELECTROSTATIC DISCHARGE (ESD) ..... 34

    8.4. RADIATED, RADIO-FREQUENCY, ELECTROMAGNETIC FIELD (RS) ..... 38

    8.5. ELECTRICAL FAST TRANSIENT (EFT) ..... 42

    8.6. SURGE IMMUNITY TEST ..... 45

    8.7. CONDUCTED RADIO FREQUENCY DISTURBANCES (CS) ..... 49

    8.8. POWER FREQUENCY MAGNETIC FIELD ..... 53

    8.9. VOLTAGE DIP & VOLTAGE INTERRUPTIONS ..... 56

9 PHOTOGRAPHS OF THE TEST CONFIGURATION ..... 59



# 1 TEST CERTIFICATION

**Product:** PCI-104 CPU Module

**Brand:** AAEON

**Model:** PFM-541IWT-xxxxxx (Where x is 0-9 , A-Z , - or blank) for marketing purpose

**Applicant:** **AAEON Technology Inc.**  
5F, No. 135, Lane 235, Pao Chiao Rd., Hsin-Tien City,  
Taipei, Taiwan, R.O.C.

**Manufacturer:** **AAEON Technology Inc.**  
5F, No. 135, Lane 235, Pao Chiao Rd., Hsin-Tien City,  
Taipei, Taiwan, R.O.C.

**Tested:** June 27, 2008 ~ July 02, 2008

**Applicable Standards:** EN 55022: 2006, Class A

EN 61000-3-2: 2006

EN 61000-3-3: 1995 + A1: 2001 + A2: 2005

EN 55024: 1998 + A1: 2001 + A2: 2003

IEC 61000-4-2: 1995 + A1: 1998 + A2: 2000

IEC 61000-4-3: 2006

IEC 61000-4-4: 2004

IEC 61000-4-5: 2005

IEC 61000-4-6: 2007

IEC 61000-4-8: 1993 + A1: 2000

IEC 61000-4-11: 2004

### Deviation from Applicable Standard

As the customers required, we adopt the above standards for testing.

The above equipment has been tested by Compliance Certification Services Inc., and found compliance with the requirements set forth in the technical standards mentioned above. The results of testing in this report apply only to the product/system, which was tested. Other similar equipment will not necessarily produce the same results due to production tolerance and measurement uncertainties.

**Approved by:**

Vince Chiang  
Assistant Manager of Sindian BU.

**Reviewed by:**

Vesta Hsu  
Supervisor of report document dept. of Sindian BU.



## 2 TEST RESULT SUMMARY

EMISSION			
Standard	Item	Result	Remarks
EN 55022: 2006	Conducted (Main Port)	PASS	Meet Class A limit
	Conducted (Telecom port)	PASS	Meet Class A limit
	Radiated	PASS	Meet Class A limit
EN 61000-3-2: 2006	Harmonic current emissions	N/A	Please see the page 27
EN 61000-3-3: 1995 + A1: 2001 + A2: 2005	Voltage fluctuations & flicker	PASS	Meets the requirements

IMMUNITY 【 EN 55024 (1998 + A1: 2001 + A2: 2003) 】			
Standard	Item	Result	Remarks
IEC 61000-4-2: 1995 + A1: 1998 + A2: 2000	ESD	PASS	Meets the requirements of Performance Criterion B
IEC 61000-4-3: 2006	RS	PASS	Meets the requirements of Performance Criterion A
IEC 61000-4-4: 2004	EFT	PASS	Meets the requirements of Performance Criterion B
IEC 61000-4-5: 2005	Surge	PASS	Meets the requirements of Performance Criterion B
IEC 61000-4-6: 2007	CS	PASS	Meets the requirements of Performance Criterion A
IEC 61000-4-8: 1993 + A1: 2000	PFMF	N/A	Please see the page 55
IEC 61000-4-11: 2004	Voltage dips & voltage variations	PASS	Meets the requirements of <b>Voltage Dips:</b> 1) >95% reduction Performance Criterion B 2) 30% reduction Performance Criterion C <b>Voltage Interruptions:</b> 1) >95% reduction Performance Criterion C.

- Note:**
1. The test result judgment is decided by the limit of test standard
  2. The information of measurement uncertainty is available upon the customer's request.



### 3 EUT DESCRIPTION

<b>Product</b>	PCI-104 CPU Module
<b>Brand Name</b>	AAEON
<b>Model</b>	PFM-541IWT-xxxxxx (Where x is 0-9 , A-Z , - or blank) for marketing
<b>Applicant</b>	AAEON Technology Inc.
<b>Housing material</b>	N/A
<b>Serial Number</b>	N/A
<b>Received Date</b>	June 27, 2008
<b>EUT Power Rating</b>	5VDC
<b>AC Power During Test</b>	230VAC / 50Hz
<b>AC Power Cord Type</b>	Unshielded, 1.8m (Detachable)
<b>OSC/Clock Frequencies</b>	25MHz; 14.31818MHz; 32.768KHz

### I/O PORT

I/O PORT TYPES	Q'TY	TESTED WITH
1) PIO Port	1	1
2) SIO Port	4	4
3) PS/2 Keyboard Port	1	1
4) PS/2 Mouse Port	1	1
5) VGA Port	1	1
6) USB Port	4	4
7) LAN Port	2	2

*Note: Client consigns only one model sample to test (Model Number: PFM-541IWT).*

## 4 TEST METHODOLOGY

### 4.1. DECISION OF FINAL TEST MODE

The EUT was tested together with the above additional components, and a configuration, which produced the worst emission levels, was selected and recorded in this report.

The test configuration/ mode is as the following:

**Mode:**

1.	<b>NORMAL MODE</b>
----	--------------------

**Conduction:** Mode 1

**Radiation:** Mode 1

### 4.2. EUT SYSTEM OPERATION

1. Windows XP boots system.
2. Run Emctest.exe to activate all peripherals and display “H” pattern on monitor screen.
3. Run Winemc.exe and choose “C:/ & F:/ & E:/ & G:/ & H:/” to test USB 2.0 ports.
4. Press the start menu, select executive and type ping 192.168.0.2-t (EUT), ping 192.168.0.1 -t (Server Notebook).
5. Press the start menu, select executive and type ping 192.168.1.2-t (EUT), ping 192.168.1.1 -t (Server Notebook).

*Note: Test program is self-repeating throughout the test.*



## 5 SETUP OF EQUIPMENT UNDER TEST

### 5.1. DESCRIPTION OF SUPPORT UNITS

The EUT has been tested as an independent unit together with other necessary accessories or support units. The following support units or accessories were used to form a representative test configuration during the tests.

#### PC Devices:

No.	Equipment	Model No.	Trade Name
1	CPU	Geode LX500MHz	AMD
2	CFD	4GB	Transcend
3	Memory (DDR400, 256MB)	V58C2512164SAJ5U	ProMos
4	Power Board	PFM-P13D-xxxxxx (Where x is 0-9 , A-Z , - or blank) for marketing purpose	AAEON
5	Power Supply	ENH-0620 (I/P: 100-240VAC)	Enhance

**Note:** Client consigns only one model sample to test (Power Board Model Number: PFM-P13D).

#### Peripherals Devices:

No.	Equipment	Model No.	Serial No.	FCC ID / BSMI ID	Trade Name	Data Cable	Power Cord
1-4	USB 2.0 HDD X4	F12-UF	N/A	BSMI ID: 4912A002	TeraSys	Shielded, 1.8m	N/A
5	PS/2 Mouse	M071KC	443029438	DOC BSMI: R41108	DELL	Shielded, 1.8m	N/A
6	PS/2 Keyboard	SK-8110	N/A	DOC BSMI: T3A002	DELL	Shielded, 1.8m	N/A
7-8	Modem X2	5JEG4033MKO	N/A	5RJTAI-35500-M5-E	TOP-SOLUTION	Shielded, 1.4m	Unshielded, 1.8m
9	Monitor	710V	GS17H9NXA05855D	DOC BSMI: R33475	SAMSUNG	Shielded, 1.8m with two cores	Unshielded, 1.8m
10	Modem	5JEG4033MKO	N/A	5RJTAI-35500-M5-E	TOP-SOLUTION	Shielded, 1.4m	Unshielded, 1.8m
11	Modem	1414	N/A	IFAXDM1414	ACEEX	Shielded, 1.4m	Unshielded, 1.8m
12	Printer	C60	N/A	BSMI ID: 3902E006	EPSON	Shielded, 1.8m	Unshielded, 1.8m
13-14	Server Notebook X2	xw4400	N/A	DOC BSMI: R33001	HP	Unshielded, 20m	Unshielded, 1.8m

#### Note:

- 1) All the equipment/cables were placed in the worst-case configuration to maximize the emission during the test.
- 2) Grounding was established in accordance with the manufacturer's requirements and conditions for the intended use.



## 5.2. CONFIGURATION OF SYSTEM UNDER TEST

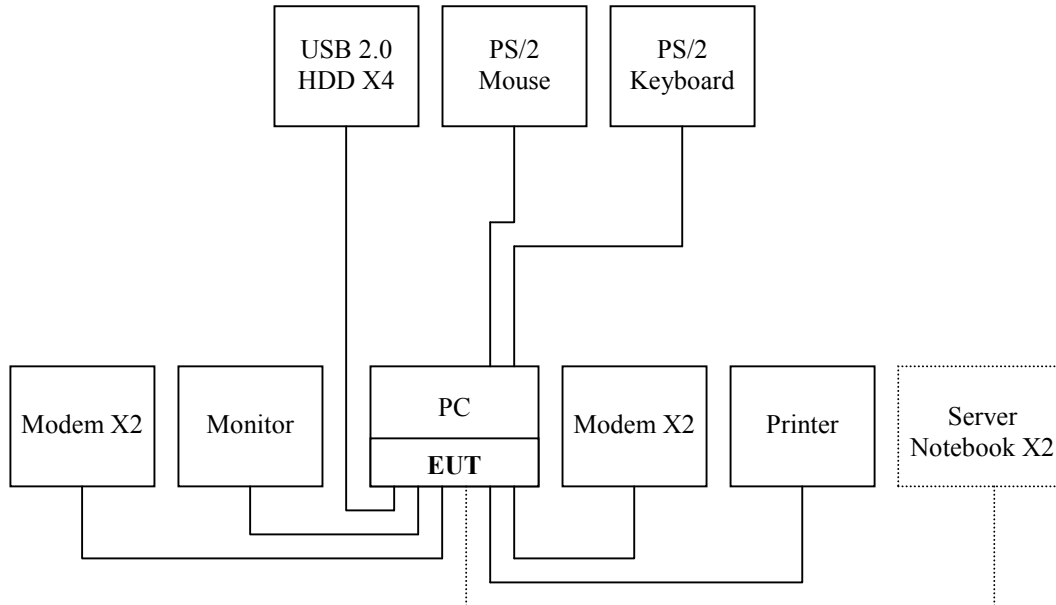

## 6 FACILITIES AND ACCREDITATIONS

### 6.1. FACILITIES

All measurement facilities used to collect the measurement data are located at CCS Taiwan Sindian BU. at No.163-1, Zhongsheng Rd., Sindian City, Taipei County 23151, Taiwan.

The sites are constructed in conformance with the requirements of ANSI C63.4 and CISPR Publication 22. All receiving equipment conforms to CISPR 16-1-1, CISPR 16-1-2, CISPR 16-1-3, CISPR 16-1-4 and CISPR 16-1-5.

### 6.2. ACCREDITATIONS

Our laboratories are accredited and approved by the following accreditation body according to ISO/IEC 17025.

<b>Taiwan</b>	TAF
<b>USA</b>	A2LA

The measuring facility of laboratories has been authorized or registered by the following approval agencies.

<b>Canada</b>	Industry Canada
<b>Germany</b>	TUV Rheinland
<b>Japan</b>	VCCI
<b>Taiwan</b>	BSMI
<b>USA</b>	FCC

Copies of granted accreditation certificates are available for downloading from our web site, <http://www.ccsemc.com.tw>

### 6.3. MEASUREMENT UNCERTAINTY

Where relevant, the following measurement uncertainty levels have been estimated for tests performed on the EUT as specified in CISPR 16-4-2:

Measurement	Frequency	Uncertainty
Conducted emissions	0.15Hz~30MHz	± 1.7376
Radiated emissions	30MHz ~ 200MHz	± 3.8792
	200MHz ~1000MHz	± 3.8914

This uncertainty represents an expanded uncertainty expressed at approximately the 95% confidence level using a coverage factor of k=2.

Consistent with industry standard (e.g. CISPR 22: 2006, clause 11, Measurement Uncertainty) determining compliance with the limits shall be base on the results of the compliance measurement. Consequently the measure emissions being less than the maximum allowed emission result in this be a compliant test or passing test.

The acceptable measurement uncertainty value without requiring revision of the compliance statement is base on conducted and radiated emissions being less than  $U_{CISPR}$  which is 3.6dB and 5.2dB respectively. CCS values (called  $U_{Lab}$  in CISPR 16-4-2) is less than  $U_{CISPR}$  as shown in the table above. Therefore, MU need not be considered for compliance.



### 7 EMISSION TEST

#### 7.1. CONDUCTED EMISSION MEASUREMENT

##### 7.1.1. LIMITS

FREQUENCY (MHz)	Class A (dBuV)		Class B (dBuV)	
	Quasi-peak	Average	Quasi-peak	Average
0.15 - 0.5	79	66	66 - 56	56 - 46
0.50 - 5.0	73	60	56	46
5.0 - 30.0	73	60	60	50

**NOTE:**

- (1) The lower limit shall apply at the transition frequencies.
- (2) The limit decreases in line with the logarithm of the frequency in the range of 0.15 to 0.50 MHz.
- (3) All emanations from a class A/B digital device or system, including any network of conductors and apparatus connected thereto, shall not exceed the level of field strengths specified above.

##### 7.1.2. TEST INSTRUMENTS

Conducted Emission room # A				
Name of Equipment	Manufacturer	Model	Serial Number	Calibration Due
TEST RECEIVER	R&S	ESHS20	840455/006	02/18/2009
LISN (EUT)	SCHWARZBECK	NSLK 8127	8127382	12/03/2008
LISN	SOLAR	8012-50-R-24-BNC	8305114	12/03/2008
BNC CABLE	MIYAZAKI	5D-FB	BNC A4	05/12/2009
THERMO-HYGRO METER	TECPEL	DTM-303	No.7	11/15/2008
Test S/W	EMI 32.exe			

- NOTE:** 1. The calibration interval of the above test instruments is 12 months and the calibrations are traceable to NML/ROC and NIST/USA.  
 2. N.C.R = No Calibration Request.



**7.1.3. TEST PROCEDURES** (please refer to measurement standard or CCS SOP PA-031)

**Procedure of Preliminary Test**

- The EUT and Support equipment, if needed, was set up as per the test configuration to simulate typical usage per the user’s manual. When the EUT is a tabletop system, a wooden table with a height of 0.8 meters is used and is placed on the ground plane as per EN 55022 (see Test Facility for the dimensions of the ground plane used). When the EUT is a floor standing equipment, it is placed on the ground plane, which has a 3-12 mm non-conductive covering to insulate the EUT from the ground plane.
- All I/O cables were positioned to simulate typical actual usage as per EN 55022.
- The test equipment EUT installed received AC main power, through a Line Impedance Stabilization Network (LISN), which supplied power source and was grounded to the ground plane.
- All support equipment power received from a second LISN.
- The EUT test program was started. Emissions were measured on each current carrying line of the EUT using an EMI Test Receiver connected to the LISN powering the EUT.
- The Receiver scanned from 150kHz to 30MHz for emissions in each of the test modes.
- During the above scans, the emissions were maximized by cable manipulation.
- The test mode(s) described in Item 3.1 were scanned during the preliminary test.
- After the preliminary scan, we found the test mode described in Item 3.1 producing the highest emission level.
- The EUT configuration and cable configuration of the above highest emission levels were recorded for reference of the final test.

**Procedure of Final Test**

- EUT and support equipment were set up on the test bench as per the configuration with highest emission level in the preliminary test.
- A scan was taken on both power lines, Line 1 and Line 2, recording at least the six highest emissions. Emission frequency and amplitude were recorded into a computer in which correction factors were used to calculate the emission level and compare reading to the applicable limit.
- The test data of the worst-case condition(s) was recorded.

**7.1.4. TEST SETUP**

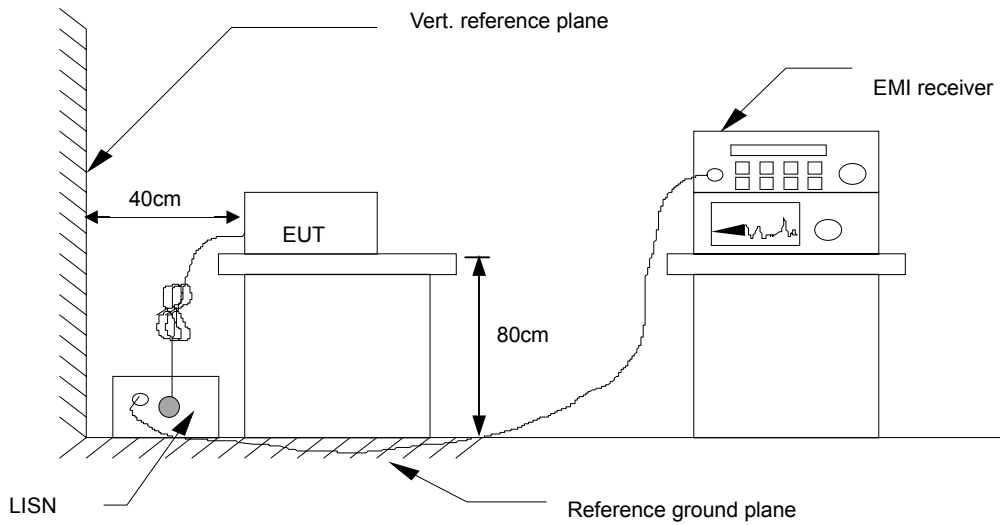

- For the actual test configuration, please refer to the related item - Photographs of the Test Configuration.

**7.1.5. DATA SAMPLE**

Freq. (MHz)	Read Level (dBuV)	Factor (dB)	Level (dBuV)	Limit Line (dBuV)	Over Limit (dB)	Remark (P/Q/A)	Line (L1/L2)
x.xx	42.95	0.55	43.50	73	-29.50	Q	L1

- Freq. = Emission frequency in MHz
- Read Level = Uncorrected Analyzer/Receiver reading
- Factor = Insertion loss of LISN + Cable Loss
- Level = Read Level + Factor
- Limit Line = Limit stated in standard
- Over Limit = Reading in reference to limit
- P = Peak Reading
- Q = Quasi-peak Reading
- A = Average Reading
- L1 = Hot side
- L2 = Neutral side

**Calculation Formula**

Over Limit (dB) = Level (dBuV) – Limit Line (dBuV)



7.1.6. TEST RESULTS

<b>Model No.</b>	PFM-541IWT	<b>6dB Bandwidth</b>	10 KHz
<b>Environmental Conditions</b>	24°C, 50% RH, 1010mbar	<b>Test Mode</b>	Mode 1
<b>Tested by</b>	Jason Lee		

(The chart below shows the highest readings taken from the final data.)

Six Highest Conducted Emission Readings							
Frequency Range Investigated				150 KHz to 30 MHz			
Freq. (MHz)	Read Level (dBuV)	Factor (dB)	Level (dBuV)	Limit Line (dBuV)	Over Limit (dB)	Remark (P/Q/A)	Line (L1/L2)
0.152	66.16	0.12	66.28	79.00	-12.72	P	L1
0.152	62.56	0.12	62.68	66.00	-3.32	A	L1
0.194	55.56	0.12	55.68	79.00	-23.32	P	L1
0.238	54.32	0.12	54.44	79.00	-24.56	P	L1
0.151	69.02	0.15	69.17	79.00	-9.83	P	L2
0.151	62.53	0.15	62.68	66.00	-3.32	A	L2
0.194	54.14	0.14	54.28	79.00	-24.72	P	L2
0.238	53.30	0.14	53.44	79.00	-25.56	P	L2

NOTE: 1. L1 = Line One (Live Line) / L2 = Line Two (Neutral Line).

2. Those frequencies only show peak emission level because that was below the Average limit, so no need to check average anymore.

**7.2. CONDUCTED EMISSION MEASUREMENT AT TELECOMMUNICATION PORTS**

**7.2.1. LIMITS**

For Class A Equipment

FREQUENCY (MHz)	Voltage Limit (dBuV)		Current Limit (dBuA)	
	Quasi-peak	Average	Quasi-peak	Average
0.15 ~ 0.5	97 ~ 87	84 ~ 74	53 ~ 43	40 ~ 30
0.5 ~ 30.0	87	74	43	30

*NOTE: The limits decrease linearly with the logarithm of the frequency in the range 0.15 MHz to 0.5 MHz.*

For Class B Equipment

FREQUENCY (MHz)	Voltage Limit (dBuV)		Current Limit (dBuA)	
	Quasi-peak	Average	Quasi-peak	Average
0.15 - 0.5	84 ~ 74	74 ~ 64	40 ~ 30	30 ~ 20
0.5 - 30.0	74	64	30	20

*NOTE: The limits decrease linearly with the logarithm of the frequency in the range 0.15 MHz to 0.5 MHz.*



7.2.2. TEST INSTRUMENTS

Conducted Emission room # A				
Name of Equipment	Manufacturer	Model	Serial Number	Calibration Due
TEST RECEIVER	R&S	ESHS20	840455/006	02/18/2009
LISN (EUT)	SCHWARZBECK	NSLK 8127	8127382	12/03/2008
LISN	SOLAR	8012-50-R-24-BNC	8305114	12/03/2008
BNC CABLE	MIYAZAKI	5D-FB	BNC A4	05/12/2009
THERMO-HYGRO METER	TECPEL	DTM-303	No.7	11/15/2008
ISN	FCC	FCC-TLISN-T4-02	20453	08/07/2008
Test S/W	EMI 32.exe			

NOTE: 1. The calibration interval of the above test instruments is 12 months and the calibrations are traceable to NML/ROC and NIST/USA.

2. N.C.R = No Calibration Request.

7.2.3. TEST PROCEDURE (please refer to measurement standard or CCS SOP PA-031)

- Selecting ISN for unscreened cable or a current probe for screened cable to take measurement.
- The port of the EUT was connected to the remote side support equipment through the ISN/Current Probe and communication in normal condition.
- Making a overall range scan by using the test receiver controlled by controller and record at least six highest emissions for showing in the test report.
- Emission frequency and amplitude were recorded into a computer in which correction factors were used to calculate the emission level and compare reading to the applicable limit.
- In case of measuring on the screened cable, the current limit shall be applied; otherwise the voltage limit should be applied.
- The following test mode(s) was scanned during the preliminary test:

Mode(s):

1.	10 Mbps
2.	100 Mbps

- After the preliminary scan, we found the following test mode(s) producing the highest emission level and test data of the worst case was recorded.

Mode: 2.



**7.2.4. TEST SETUP**

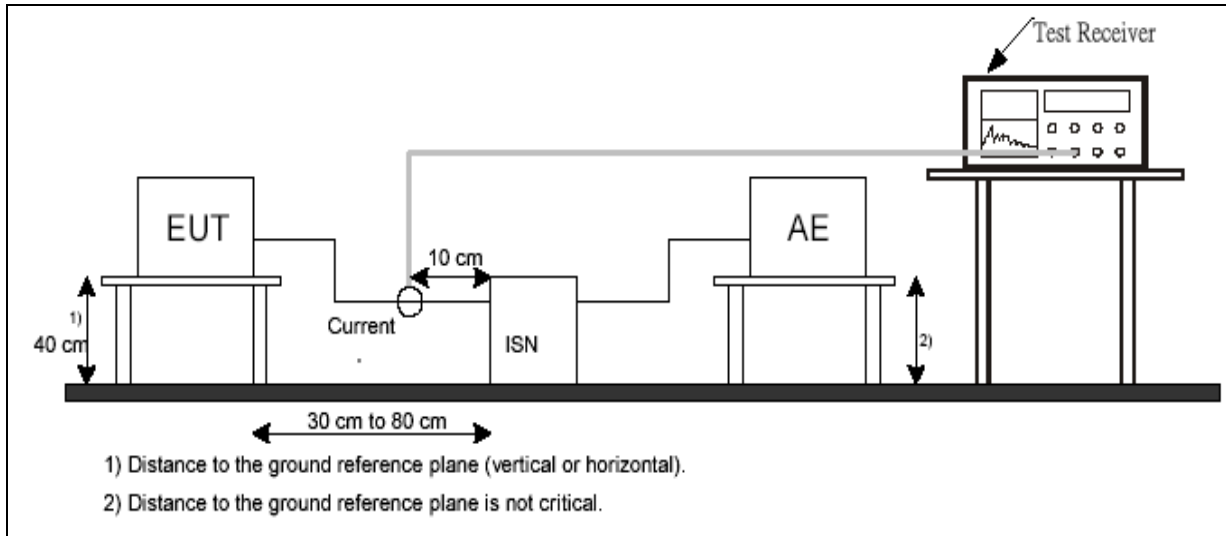

- For the actual test configuration, please refer to the related item – Photographs of the Test Configuration.

**7.2.5. DATA SAMPLE**

Freq. (MHz)	Read Level (dBuV)	Factor (dB)	Level (dBuV)	Limit Line (dBuV)	Over Limit (dB)	Remark (P/Q/A)
x.xx	62.95	0.55	63.50	87	-23.50	Q

- Freq. = Emission frequency in MHz
- Read Level = Uncorrected Analyzer/Receiver reading
- Factor = Insertion loss of ISN + Cable Loss
- Level = Read Level + Factor
- Limit = Limit stated in standard
- Over Limit = Reading in reference to limit
- P = Peak Reading
- Q = Quasi-peak Reading
- A = Average Reading

**Calculation Formula**

Over Limit (dB) = Level (dBuV) – Limit (dBuV)



7.2.6. TEST RESULTS

<b>Model No.</b>	PFM-541IWT	<b>6dB Bandwidth</b>	10 KHz
<b>Environmental Conditions</b>	24°C, 50% RH, 1010mbar	<b>Test Mode</b>	Mode 2
<b>Tested by</b>	Jason Lee		

(The chart below shows the highest readings taken from the final data.)

<b>Six Highest Conducted Emission Readings</b>						
<b>Frequency Range Investigated</b>				<b>150 KHz to 30 MHz</b>		
<b>Freq. (MHz)</b>	<b>Read Level (dBuV)</b>	<b>Factor (dB)</b>	<b>Level (dBuV)</b>	<b>Limit Line (dBuV)</b>	<b>Over Limit (dB)</b>	<b>Remark (P/Q/A)</b>
5.898	43.52	9.81	53.33	87.00	-33.67	P
12.188	48.08	9.88	57.96	87.00	-29.04	P
13.408	48.46	9.89	58.35	87.00	-28.65	P
15.552	46.90	9.91	56.81	87.00	-30.19	P
16.750	45.18	9.93	55.11	87.00	-31.89	P
26.001	41.98	10.03	52.01	87.00	-34.99	P

NOTE: The emission level was or more than 2dB below the Average limit, so no re-check anymore.



7.3. RADIATED EMISSION MEASUREMENT

7.3.1. LIMITS

FREQUENCY (MHz)	dBuV/m (At 10m)	
	Class A	Class B
30 ~ 230	40	30
230 ~ 1000	47	37

**NOTE:** (1) The lower limit shall apply at the transition frequencies.  
 (2) Emission level (dBuV/m) = 20 log Emission level (uV/m).

7.3.2. TEST INSTRUMENTS

Open Area Test Site # I				
Name of Equipment	Manufacturer	Model	Serial Number	Calibration Due
SITE NSA	CCS	I Site	N/A	09/28/2008
MEASURE RECEIVER	SCHAFFNER	SCR3501	338	07/03/2008
SPECTRUM ANALYZER	ADVANTEST	R3132	120900008	No Calibration Required
ANTENNA	SCHAFFNER	CBL 6112B	2809	09/21/2008
AMPLIFIER	SCHAFFNER	CPA9231A	3626	10/10/2008
CABLE	BELDEN	9913	N-TYPE #12	02/24/2009
ATTENUATOR	MCL	UNAT-6	AT06-3	10/10/2008
THERMO-HYGRO METER	TFA	N/A	NO.2	12/03/2008
Test S/W	Lab VIEW 7.1			

**NOTE:** 1. The calibration interval of the above test instruments is 12 months and the calibrations are traceable to NML/ROC and NIST/USA.  
 2. N.C.R = No Calibration Request.

**7.3.3. TEST PROCEDURE** (please refer to measurement standard or CCS SOP PA-031)**Procedure of Preliminary Test**

- The equipment was set up as per the test configuration to simulate typical usage per the user's manual. When the EUT is a tabletop system, a wooden turntable with a height of 0.8 meters is used which is placed on the ground plane. When the EUT is a floor standing equipment, it is placed on the ground plane which has a 3-12 mm non-conductive covering to insulate the EUT from the ground plane.
- Support equipment, if needed, was placed as per EN 55022.
- All I/O cables were positioned to simulate typical usage as per EN 55022.
- The EUT received AC power source from the outlet socket under the turntable. All support equipment power received from another socket under the turntable.
- The antenna was placed at 10 meter away from the EUT as stated in EN 55022. The antenna connected to the Spectrum Analyzer via a cable and at times a pre-amplifier would be used.
- The Analyzer / Receiver quickly scanned from 30MHz to 1000MHz. The EUT test program was started. Emissions were scanned and measured rotating the EUT to 360 degrees and positioning the antenna 1 to 4 meters above the ground plane, in both the vertical and the horizontal polarization, to maximize the emission reading level.
- The test mode(s) described in Item 3.1 were scanned during the preliminary test:
- After the preliminary scan, we found the test mode described in Item 3.1 producing the highest emission level.
- The EUT and cable configuration, antenna position, polarization and turntable position of the above highest emission level were recorded for the final test.



**Procedure of Final Test**

- EUT and support equipment were set up on the turntable as per the configuration with highest emission level in the preliminary test.
- The Analyzer / Receiver scanned from 30MHz to 1000MHz. Emissions were scanned and measured rotating the EUT to 360 degrees, varying cable placement and positioning the antenna 1 to 4 meters above the ground plane, in both the vertical and the horizontal polarization, to maximize the emission reading level.
- Recorded at least the six highest emissions. Emission frequency, amplitude, antenna position, polarization and turntable position were recorded into a computer in which correction factors were used to calculate the emission level and compare reading to the applicable limit and only Q.P. reading is presented.
- The test data of the worst-case condition(s) was recorded.

**7.3.4. TEST SETUP**

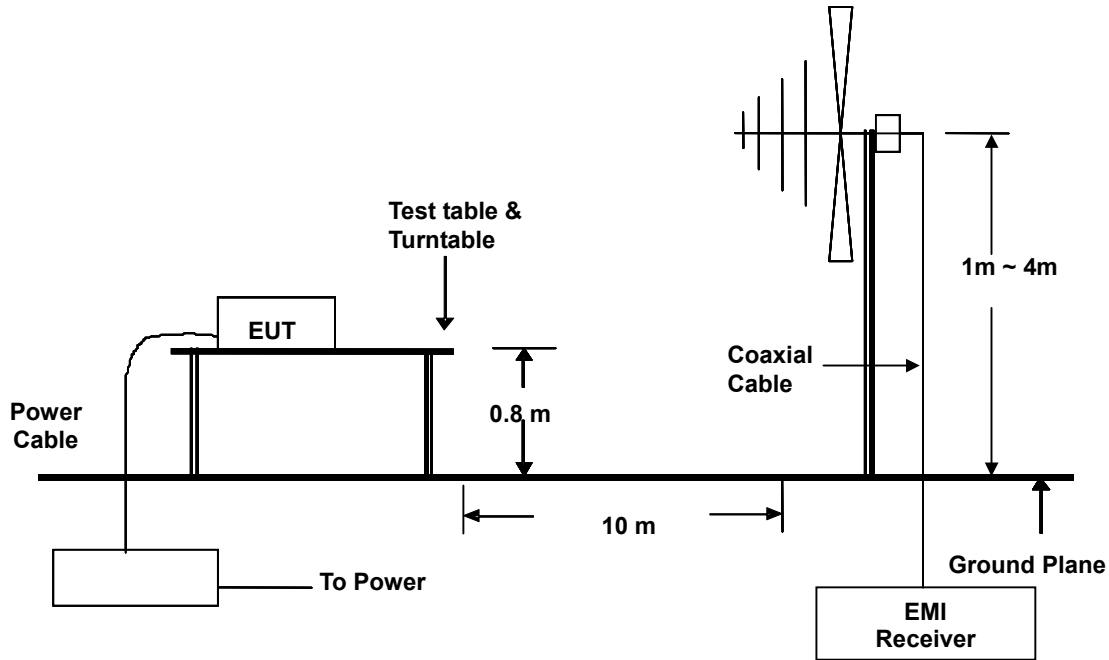

- For the actual test configuration, please refer to the related item – Photographs of the Test Configuration.

**7.3.5. DATA SAMPLE**

Freq. (MHz)	Reading (dBUV)	Factor (dB)	Result (dBUV/m)	Limit (dBUV/m)	Margin (dB)	Remark (P/Q/A)	Pol. (H/V)
x.xx	14.0	12.2	26.2	40	-13.8	Q	H

- Freq. = Emission frequency in MHz
- Reading = Uncorrected Analyzer/Receiver reading
- Factor = Antenna Factor + Cable Loss + Attenuator (3/6/10dB) – Amplifier Gain
- Result = Uncorrected Analyzer/Receiver reading + Factor
- Limit = Limit stated in standard
- Margin = Reading in reference to limit
- P = Peak Reading
- Q = Quasi-peak Reading
- A = Average Reading
- H = Antenna Polarization: Horizontal
- V = Antenna Polarization: Vertical

**Calculation Formula**

Margin (dB) = Level (dBUV/m) – Limit (dBUV/m)



7.3.6. TEST RESULTS

<b>Model No.</b>	PFM-541IWT	<b>Test Mode</b>	Mode 1
<b>Environmental Conditions</b>	25°C, 55% RH, 1005mbar	<b>6dB Bandwidth</b>	120 KHz
<b>Antenna Pole</b>	Vertical	<b>Antenna Distance</b>	10m
<b>Detector Function</b>	Quasi-peak.	<b>Tested by</b>	John Yen

(The chart below shows the highest readings taken from the final data.)

Six Highest Radiated Emission Readings							
Frequency Range Investigated				30 MHz to 1000 MHz at 10m			
Freq. (MHz)	Reading (dBuV)	Factor (dB)	Result (dBuV/m)	Limit (dBuV/m)	Margin (dB)	Remark (P/Q/A)	Pol. (H/V)
31.782	40.00	-4.46	35.54	40.00	-4.46	Q	V
52.231	49.00	-14.28	34.72	40.00	-5.28	Q	V
117.517	44.70	-9.50	35.20	40.00	-4.80	Q	V
208.921	47.80	-10.26	37.54	40.00	-2.46	Q	V
240.110	48.00	-8.44	39.56	47.00	-7.44	Q	V
280.748	48.79	-8.35	40.44	47.00	-6.56	Q	V

**REMARKS:** 1. P= Peak Reading; Q= Quasi-peak Reading A= Average Reading.  
 2. The other emission levels were very low against the limit.



<b>Model No.</b>	PFM-541IWT	<b>Test Mode</b>	Mode 1
<b>Environmental Conditions</b>	25°C, 55% RH, 1005mbar	<b>6dB Bandwidth</b>	120 KHz
<b>Antenna Pole</b>	Horizontal	<b>Antenna Distance</b>	10m
<b>Detector Function</b>	Quasi-peak.	<b>Tested by</b>	John Yen

(The chart below shows the highest readings taken from the final data.)

Six Highest Radiated Emission Readings							
Frequency Range Investigated				30 MHz to 1000 MHz at 10m			
Freq. (MHz)	Reading (dBuV)	Factor (dB)	Result (dBuV/m)	Limit (dBuV/m)	Margin (dB)	Remark (P/Q/A)	Pol. (H/V)
117.530	40.65	-9.50	31.15	40.00	-8.85	Q	H
126.480	42.52	-9.64	32.88	40.00	-7.12	Q	H
208.921	46.60	-10.26	36.34	40.00	-3.66	Q	H
240.100	47.85	-8.44	39.41	47.00	-7.59	Q	H
261.220	46.84	-8.53	38.31	47.00	-8.69	Q	H
364.321	44.00	-5.14	38.86	47.00	-8.14	Q	H

**REMARKS:** 1. P= Peak Reading; Q= Quasi-peak Reading A= Average Reading.  
 2. The other emission levels were very low against the limit.





**7.4. HARMONICS CURRENT MEASUREMENT**

**7.4.1. LIMITS OF HARMONICS CURRENT MEASUREMENT**

Limits for Class A equipment		Limits for Class D equipment		
Harmonics Order n	Max. permissible harmonics current A	Harmonics Order n	Max. permissible harmonics current per watt mA/W	Max. permissible harmonics current A
Odd harmonics		Odd Harmonics only		
3	2.30	3	3.4	2.30
5	1.14	5	1.9	1.14
7	0.77	7	1.0	0.77
9	0.40	9	0.5	0.40
11	0.33	11	0.35	0.33
13	0.21	13	0.30	0.21
15<=n<=39	0.15x15/n	15<=n<=39	3.85/n	0.15x15/n
Even harmonics				
2	1.08			
4	0.43			
6	0.30			
8<=n<=40	0.23x8/n			

**NOTE:** 1. Class A and Class D are classified according to item 4.4.3.  
 2. According to section 7 of EN 61000-3-2, the above limits for all equipment except for lighting equipment having an active input power > 75 W and no limits apply for equipment with an active input power up to and including 75 W.

**7.4.2. TEST INSTRUMENTS**

Name of Equipment	Manufacturer	Model	Serial Number	Calibration Due
Signal Conditioning Unit	Schaffner	CCN 1000-1	72122	11/22/2008
5KVA AC Power Source	Schaffner	NSG 1007	55131	No Calibration Required
Software	Win2100V3.exe			

**NOTE:** 1. The calibration interval of the above test instruments is 12 months and the calibrations are traceable to NML/ROC and NIST/USA.

**7.4.3. TEST PROCEDURE** (please refer to measurement standard or CCS SOP PA-029)

- The EUT was placed on the top of a wooden table 0.8 meters above the ground and operated to produce the maximum harmonic components under normal operating conditions for each successive harmonic component in turn.
- The classification of EUT is according to section 5 of EN 61000-3-2.
- The EUT is classified as follows:
  - Class A: Balanced three-phase equipment, Household appliances excluding equipment as Class D, Tools excluding portable tools, Dimmers for incandescent lamps, audio equipment, equipment not specified in one of the three other classes.
  - Class B: Portable tools; Arc welding equipment which is not professional equipment.
  - Class C: Lighting equipment.
  - Class D: Equipment having a specified power less than or equal to 600 W of the following types:
    - Personal computers and personal computer monitors and television receivers.
- The correspondent test program of test instrument to measure the current harmonics emanated from EUT is chosen. The measure time shall be not less than the time necessary for the EUT to be exercised.

**7.4.4. TEST SETUP**

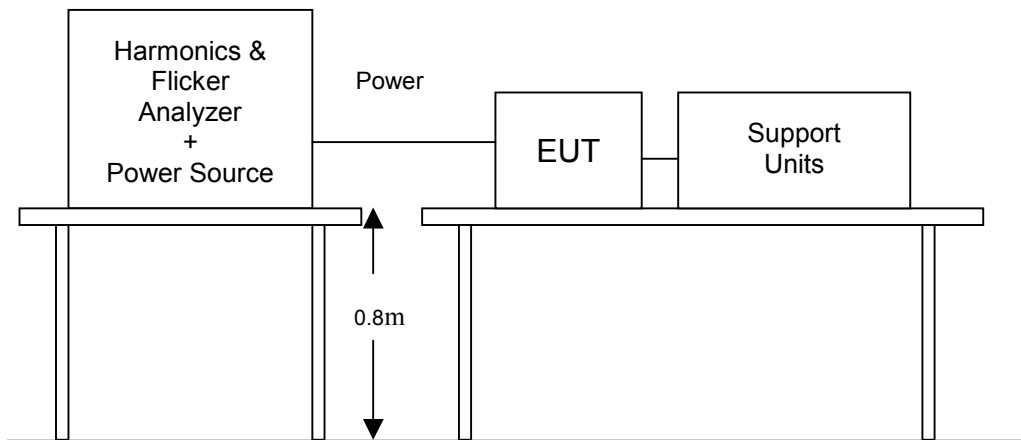

- For the actual test configuration, please refer to the related item – Photographs of the Test Configuration.

**7.4.5. TEST RESULTS**

<b>Power Consumption</b>	29.4 W	<b>Test Results</b>	N/A
<b>Environmental Conditions</b>	18°C, 50% RH, 1010mbar	<b>Limits</b>	Class <input type="checkbox"/> A <input type="checkbox"/> B <input type="checkbox"/> C <input type="checkbox"/> D
<b>Test Mode</b>	Operating	<b>Tested by</b>	Jason Chia

**NOTE:** 1. Limits classified according to item 7.4.3.  
 2. According to clause 7 of EN 61000-3-2: 2006, equipment with a rated power of 75W or less, no limits apply. The test result is only for reference.



7.5. VOLTAGE FLUCTUATION AND FLICKER MEASUREMENT

7.5.1. LIMITS OF VOLTAGE FLUCTUATION AND FLICKER MEASUREMENT

TEST ITEM	LIMIT	REMARK
P <sub>st</sub>	1.0	P <sub>st</sub> means short-term flicker indicator.
P <sub>lt</sub>	0.65	P <sub>lt</sub> means long-term flicker indicator.
T <sub>dt</sub> (ms)	500	T <sub>dt</sub> means maximum time that dt exceeds 3 %.
d <sub>max</sub> (%)	4%	d <sub>max</sub> means maximum relative voltage change.
dc (%)	3.3%	dc means relative steady-state voltage change

7.5.2. TEST INSTRUMENTS

Name of Equipment	Manufacturer	Model	Serial Number	Calibration Due
Signal Conditioning Unit	Schaffner	CCN 1000-1	72122	11/22/2008
5KVA AC Power Source	Schaffner	NSG 1007	55131	No Calibration Required
Software	Win2100V3.exe			

NOTE: 1. The calibration interval of the above test instruments is 12 months and the calibrations are traceable to NML/ROC and NIST/USA.

**7.5.3. TEST PROCEDURE** (please refer to measurement standard or CCS SOP PA-030)

- The EUT was placed on the top of a wooden table 0.8 meters above the ground and operated to produce the most unfavorable sequence of voltage changes under normal operating conditions.
- During the flick measurement, the measure time shall include that part of whole operation cycle in which the EUT produce the most unfavorable sequence of voltage changes. The observation period for short-term flicker indicator is 10 minutes and the observation period for long-term flicker indicator is 2 hours.

**7.5.4. TEST SETUP**

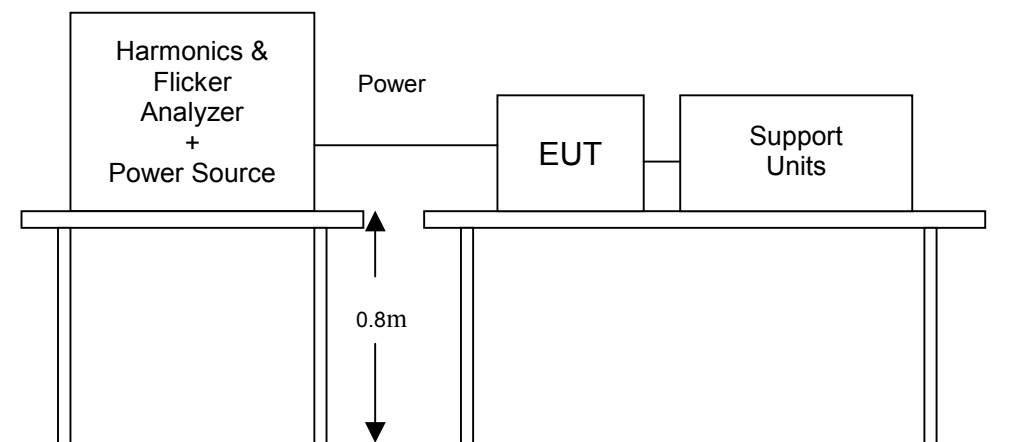

- For the actual test configuration, please refer to the related item – Photographs of the Test Configuration.



7.5.5. TEST RESULTS

Observation Period (Tp)	10mins	Test Mode	Operating
Environmental Conditions	18°C, 50% RH, 1010mbar	Tested by	Jason Chia

TEST PARAMETER	MEASUREMENT VALUE	LIMIT	REMARK
P <sub>st</sub>	0.064	1.0	PASS
P <sub>lt</sub>	0.040	0.65	PASS
T <sub>dt</sub> (ms)	0.0	500	PASS
d <sub>max</sub> (%)	0.00	4%	PASS
dc (%)	0.00	3.3%	PASS

Note: None.



TEST RESULT OF EN 61000-3-3

Test Result: Pass

Status: Test Completed

Pst and limit line

European Limits



Plt and limit line

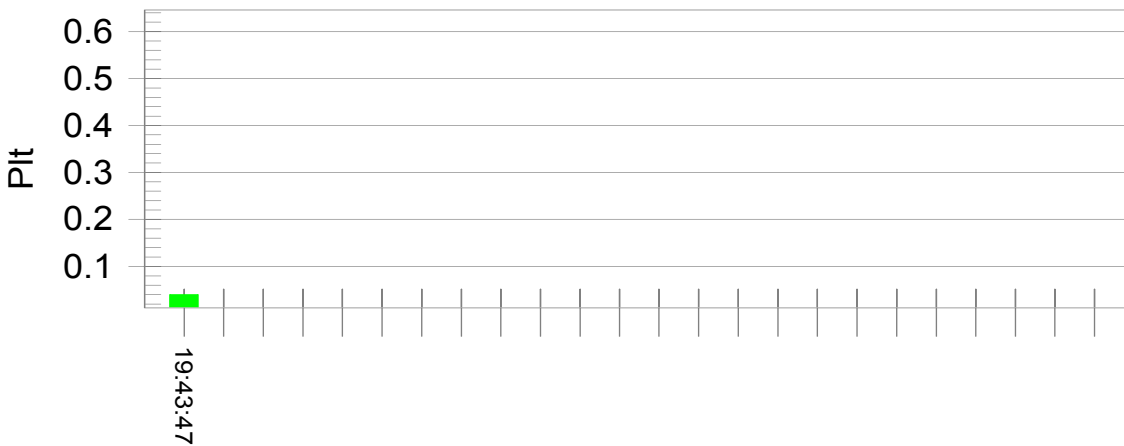

Parameter values recorded during the test:

Vrms at the end of test (Volt):	230.11			
Highest dt (%):	0.00	Test limit (%):	3.14	Pass
Time(mS) > dt:	0.0	Test limit (mS):	500.0	Pass
Highest dc (%):	0.00	Test limit (%):	3.14	Pass
Highest dmax (%):	0.00	Test limit (%):	3.80	Pass
Highest Pst (10 min. period):	0.064	Test limit:	0.950	Pass
Highest Plt (2 hr. period):	0.040	Test limit:	0.617	Pass

## 8 IMMUNITY TEST

### 8.1. GENERAL DESCRIPTION

Product Standard	EN 55024: 1998 + A1: 2001 + A2: 2003	
	Test Type	Minimum Requirement
<b>Basic Standard, Specification, and Performance Criterion required</b>	IEC 61000-4-2	Electrostatic Discharge – ESD: 8KV air discharge, 4KV Contact discharge, Performance Criterion B
	IEC 61000-4-3	Radio-Frequency Electromagnetic Field Susceptibility Test – RS: 80 ~1000 MHz, 3V/m, 80% AM(1kHz), Performance Criterion A
	IEC 61000-4-4	Electrical Fast Transient/Burst - EFT, Power line: 1KV, Signal line: 0.5KV, Performance Criterion B
	IEC 61000-4-5	Surge Immunity Test: 1.2/50 us Open Circuit Voltage, 8 /20 us Short Circuit Current, Power Port ~ Line to line: 1KV, Line to ground: 2KV Signal Port ~ Lines to ground: 1KV Performance Criterion B
	IEC 61000-4-6	Conducted Radio Frequency Disturbances Test – CS: 0.15 ~ 80 MHz, 3Vrms, 80% AM, 1kHz, Performance Criterion A
	IEC 61000-4-8	Power frequency magnetic field immunity test 50 Hz, 1A/m Performance Criterion A
	IEC 61000-4-11	<b>Voltage Dips:</b> i) >95% reduction for 0.5 period, Performance Criterion B ii) 30% reduction for 25 period, Performance Criterion C <b>Voltage Interruptions:</b> >95% reduction for 250 period Performance Criterion C





## 8.2. GENERAL PERFORMANCE CRITERIA DESCRIPTION

<b>Criteria A:</b>	The apparatus shell continues to operate as intended without operator intervention. No degradation of performance or loss of function is allowed below a performance level specified by the manufacturer, when the apparatus is used as intended. The performance level may be replaced by a permissible loss of performance. If the manufacturer does not specify the minimum performance level or the permissible performance loss, then either of these may be derived from the product description and documentation, and by what the user may reasonably expect from the equipment if used as intended.
<b>Criteria B:</b>	After test, the apparatus shell continues to operate as intended without operator intervention. No degradation of performance or loss of function is allowed, after the application of the phenomenon below a performance level specified by the manufacturer, when the apparatus is used as intended. The performance level may be replaced by a permissible loss of performance.  During the test, degradation of performance is however allowed. However, no change of operating state if stored data is allowed to persist after the test. If the manufacturer does not specify the minimum performance level or the permissible performance loss, then either of these may be derived from the product description and documentation, and by what the user may reasonably expect from the equipment if used as intended.
<b>Criteria C:</b>	Temporary loss of function is allowed, provided the functions is self-recoverable or can be restored by the operation of controls by the user in accordance with the manufacturer instructions.  Functions, and/or information stored in non-volatile memory, or protected by a battery backup, shall not be lost.



8.3. ELECTROSTATIC DISCHARGE (ESD)

8.3.1. TEST SPECIFICATION

<b>Basic Standard:</b>	EN 61000-4-2
<b>Discharge Impedance:</b>	330 ohm / 150 pF
<b>Discharge Voltage:</b>	Air Discharge: 2 ; 4 ; 8 KV (Direct) Contact Discharge: 2 ; 4 KV (Direct/Indirect)
<b>Polarity:</b>	Positive & Negative
<b>Number of Discharge:</b>	Minimum 10 times at each test point
<b>Discharge Mode:</b>	Single Discharge 1 second minimum

8.3.2. TEST INSTRUMENT

IMMUNITY SHIELDED ROOM				
Name of Equipment	Manufacturer	Model	Serial Number	Calibration Due
ESD Simulator	Schaffner	NSG 438	129	04/29/2009
Aneroid Barometer	Sato	7610-20	89090	12/09/2008
Thermo-Hygro meter	TECPEL	DTM-303	No.7	11/15/2008

NOTE: The calibration interval of the above test instruments is 12 months and the calibrations are traceable to NML/ROC and NIST/USA.

**8.3.3. TEST PROCEDURE** (please refer to measurement standard or CCS SOP PA-022)

The discharges shall be applied in two ways:

a) Contact discharges to the conductive surfaces and coupling planes:

The EUT shall be exposed to at least 200 discharges, 100 each at negative and positive polarity, at a minimum of four test points. One of the test points shall be subjected to at least 50 indirect discharges to the center of the front edge of the **Horizontal Coupling Plane (HCP)**. The remaining three test points shall each receive at least 50 direct contact discharges. If no direct contact test points are available, then at least 200 indirect discharges shall be applied in the indirect mode. Test shall be performed at a maximum repetition rate of one discharge per second.

b) Air discharges at slots and apertures and insulating surfaces:

On those parts of the EUT where it is not possible to perform contact discharge testing, the equipment should be investigated to identify user accessible points where breakdown may occur. Such points are tested using the air discharge method. This investigation should be restricted to those area normally handled by the user. A minimum of 10 single air discharges shall be applied to the selected test point for each such area.

The basic test procedure was in accordance with IEC 61000-4-2:

- a) The EUT was located 0.1 m minimum from all side of the **HCP** (dimensions 1.6m x 0.8m).
- b) The support units were located another table 30 cm away from the EUT, but direct support unit was/were located at same location as EUT on the HCP and keep at a distance of 10 cm with EUT.
- c) The time interval between two successive single discharges was at least 1 second.
- d) Contact discharges were applied to the non-insulating coating, with the pointed tip of the generator penetrating the coating and contacting the conducting substrate.
- e) Air discharges were applied with the round discharge tip of the discharge electrode approaching the EUT as fast as possible (without causing mechanical damage) to touch the EUT. After each discharge, the ESD generator was removed from the EUT and re-triggered for a new single discharge. The test was repeated until all discharges were complete.
- f) At least ten single discharges (in the most sensitive polarity) were applied at the front edge of each **HCP** opposite the center point of each unit of the EUT and 0.1 meters from the front of the EUT. The long axis of the discharge electrode was in the plane of the **HCP** and perpendicular to its front edge during the discharge.
- g) At least ten single discharges (in the most sensitive polarity) were applied to the center of one vertical edge of the **Vertical Coupling Plane (VCP)** in sufficiently different positions that the four faces of the EUT were completely illuminated. The **VCP** (dimensions 0.5m x 0.5m) was placed vertically to and 0.1 meters from the EUT.

**8.3.4. TEST SETUP**

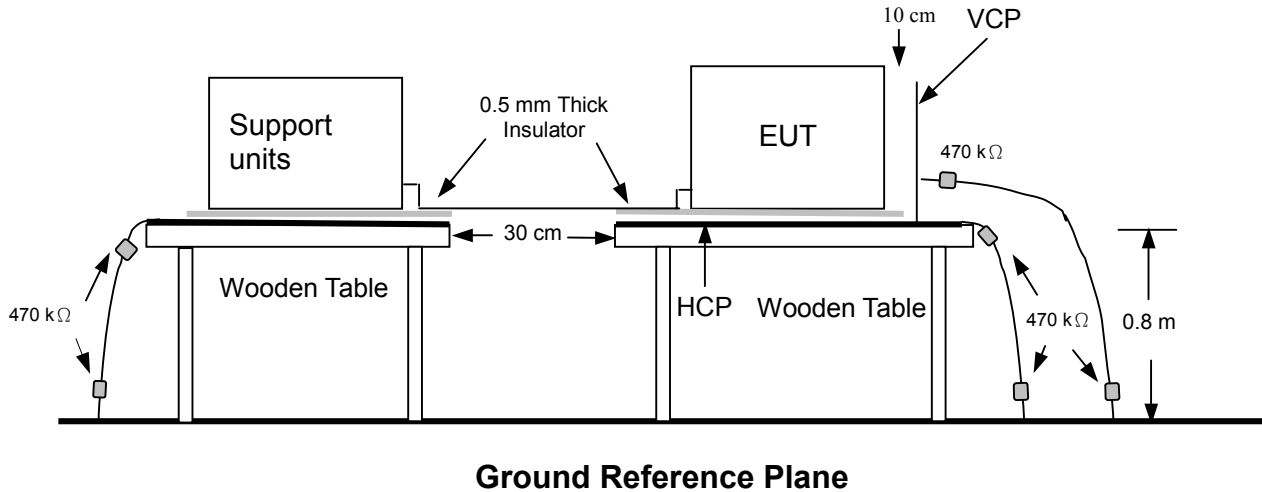

- For the actual test configuration, please refer to the related item – Photographs of the Test Configuration.

**NOTE:**

TABLE-TOP EQUIPMENT

The configuration consisted of a wooden table 0.8 meters high standing on the **Ground Reference Plane**. The **GRP** consisted of a sheet of aluminum at least 0.25mm thick, and 2.5 meters square connected to the protective grounding system. A **Horizontal Coupling Plane** (1.6m x 0.8m) was placed on the table and attached to the **GRP** by means of a cable with 940k total impedance. The equipment under test, was installed in a representative system as described in section 7 of EN 61000-4-2, and its cables were placed on the **HCP** and isolated by an insulating support of 0.5mm thickness. A distance of 1-meter minimum was provided between the EUT and the walls of the laboratory and any other metallic structure.

FLOOR-STANDING EQUIPMENT

The equipment under test was installed in a representative system as described in section 7 of IEC 61000-4-2, and its cables were isolated from the Ground Reference Plane by an insulating support of 0.1-meter thickness. The GRP consisted of a sheet of aluminum that is at least 0.25mm thick, and 2.5 meters square connected to the protective grounding system and extended at least 0.5 meters from the EUT on all sides.



8.3.5. TEST RESULTS

Temperature	18°C	Humidity	50% RH
Pressure	1010mbar	Tested By	Jason Chia
Required Passing Performance		Criterion B	

Air Discharge								
Test Points	Test Levels			Results				
	± 2 KV	± 4 KV	± 8 KV	Pass	Fail	Performance Criterion		Observation
Front	<input checked="" type="checkbox"/>	<input checked="" type="checkbox"/>	<input checked="" type="checkbox"/>	<input checked="" type="checkbox"/>	<input type="checkbox"/>	<input checked="" type="checkbox"/> A	<input type="checkbox"/> B	Note <input type="checkbox"/> 1 <input checked="" type="checkbox"/> 2
Back	<input checked="" type="checkbox"/>	<input checked="" type="checkbox"/>	<input checked="" type="checkbox"/>	<input checked="" type="checkbox"/>	<input type="checkbox"/>	<input checked="" type="checkbox"/> A	<input type="checkbox"/> B	Note <input type="checkbox"/> 1 <input checked="" type="checkbox"/> 2
Left	<input checked="" type="checkbox"/>	<input checked="" type="checkbox"/>	<input checked="" type="checkbox"/>	<input checked="" type="checkbox"/>	<input type="checkbox"/>	<input checked="" type="checkbox"/> A	<input type="checkbox"/> B	Note <input type="checkbox"/> 1 <input checked="" type="checkbox"/> 2
Right	<input checked="" type="checkbox"/>	<input checked="" type="checkbox"/>	<input checked="" type="checkbox"/>	<input checked="" type="checkbox"/>	<input type="checkbox"/>	<input checked="" type="checkbox"/> A	<input type="checkbox"/> B	Note <input type="checkbox"/> 1 <input checked="" type="checkbox"/> 2
Top	<input checked="" type="checkbox"/>	<input checked="" type="checkbox"/>	<input checked="" type="checkbox"/>	<input checked="" type="checkbox"/>	<input type="checkbox"/>	<input checked="" type="checkbox"/> A	<input type="checkbox"/> B	Note <input type="checkbox"/> 1 <input checked="" type="checkbox"/> 2

Contact Discharge								
Test Points	Test Levels			Results				
	± 2 KV	± 4 KV	± 8 KV	Pass	Fail	Performance Criterion		Observation
Front	<input checked="" type="checkbox"/>	<input checked="" type="checkbox"/>	<input type="checkbox"/>	<input checked="" type="checkbox"/>	<input type="checkbox"/>	<input checked="" type="checkbox"/> A	<input type="checkbox"/> B	Note <input checked="" type="checkbox"/> 1 <input type="checkbox"/> 2
Back	<input checked="" type="checkbox"/>	<input checked="" type="checkbox"/>	<input type="checkbox"/>	<input checked="" type="checkbox"/>	<input type="checkbox"/>	<input checked="" type="checkbox"/> A	<input type="checkbox"/> B	Note <input checked="" type="checkbox"/> 1 <input type="checkbox"/> 2
Left	<input checked="" type="checkbox"/>	<input checked="" type="checkbox"/>	<input type="checkbox"/>	<input checked="" type="checkbox"/>	<input type="checkbox"/>	<input checked="" type="checkbox"/> A	<input type="checkbox"/> B	Note <input checked="" type="checkbox"/> 1 <input type="checkbox"/> 2
Right	<input checked="" type="checkbox"/>	<input checked="" type="checkbox"/>	<input type="checkbox"/>	<input checked="" type="checkbox"/>	<input type="checkbox"/>	<input checked="" type="checkbox"/> A	<input type="checkbox"/> B	Note <input checked="" type="checkbox"/> 1 <input type="checkbox"/> 2
Top	<input checked="" type="checkbox"/>	<input checked="" type="checkbox"/>	<input type="checkbox"/>	<input checked="" type="checkbox"/>	<input type="checkbox"/>	<input checked="" type="checkbox"/> A	<input type="checkbox"/> B	Note <input checked="" type="checkbox"/> 1 <input type="checkbox"/> 2

Please refer to ESD test photo on next page for detail discharge point

Discharge To Horizontal Coupling Plane								
Side of EUT	Test Levels			Results				
	± 2 KV	± 4 KV	± 8 KV	Pass	Fail	Performance Criterion		Observation
Front	<input checked="" type="checkbox"/>	<input checked="" type="checkbox"/>	<input type="checkbox"/>	<input checked="" type="checkbox"/>	<input type="checkbox"/>	<input checked="" type="checkbox"/> A	<input type="checkbox"/> B	Note <input checked="" type="checkbox"/> 1 <input type="checkbox"/> 2
Back	<input checked="" type="checkbox"/>	<input checked="" type="checkbox"/>	<input type="checkbox"/>	<input checked="" type="checkbox"/>	<input type="checkbox"/>	<input checked="" type="checkbox"/> A	<input type="checkbox"/> B	Note <input checked="" type="checkbox"/> 1 <input type="checkbox"/> 2
Left	<input checked="" type="checkbox"/>	<input checked="" type="checkbox"/>	<input type="checkbox"/>	<input checked="" type="checkbox"/>	<input type="checkbox"/>	<input checked="" type="checkbox"/> A	<input type="checkbox"/> B	Note <input checked="" type="checkbox"/> 1 <input type="checkbox"/> 2
Right	<input checked="" type="checkbox"/>	<input checked="" type="checkbox"/>	<input type="checkbox"/>	<input checked="" type="checkbox"/>	<input type="checkbox"/>	<input checked="" type="checkbox"/> A	<input type="checkbox"/> B	Note <input checked="" type="checkbox"/> 1 <input type="checkbox"/> 2

Discharge To Vertical Coupling Plane								
Side of EUT	Test Levels			Results				
	± 2 KV	± 4 KV	± 8 KV	Pass	Fail	Performance Criterion		Observation
Front	<input checked="" type="checkbox"/>	<input checked="" type="checkbox"/>	<input type="checkbox"/>	<input checked="" type="checkbox"/>	<input type="checkbox"/>	<input checked="" type="checkbox"/> A	<input type="checkbox"/> B	Note <input checked="" type="checkbox"/> 1 <input type="checkbox"/> 2
Back	<input checked="" type="checkbox"/>	<input checked="" type="checkbox"/>	<input type="checkbox"/>	<input checked="" type="checkbox"/>	<input type="checkbox"/>	<input checked="" type="checkbox"/> A	<input type="checkbox"/> B	Note <input checked="" type="checkbox"/> 1 <input type="checkbox"/> 2
Left	<input checked="" type="checkbox"/>	<input checked="" type="checkbox"/>	<input type="checkbox"/>	<input checked="" type="checkbox"/>	<input type="checkbox"/>	<input checked="" type="checkbox"/> A	<input type="checkbox"/> B	Note <input checked="" type="checkbox"/> 1 <input type="checkbox"/> 2
Right	<input checked="" type="checkbox"/>	<input checked="" type="checkbox"/>	<input type="checkbox"/>	<input checked="" type="checkbox"/>	<input type="checkbox"/>	<input checked="" type="checkbox"/> A	<input type="checkbox"/> B	Note <input checked="" type="checkbox"/> 1 <input type="checkbox"/> 2

**NOTE:** 1. There was no change compared with initial operation during the test.  
 2. Not applicable. (Metal case)



8.4. RADIATED, RADIO-FREQUENCY, ELECTROMAGNETIC FIELD (RS)

8.4.1. TEST SPECIFICATION

**Basic Standard:** EN 61000-4-3  
**Frequency Range:** 80 MHz ~1000 MHz  
**Field Strength:** 3 V/m  
**Modulation:** 1kHz Sine Wave, 80%, AM Modulation  
**Frequency Step:** 1 % of preceding frequency value  
**Polarity of Antenna:** Horizontal and Vertical  
**Test Distance:** 3 m  
**Antenna Height:** 1.5 m

8.4.2. TEST INSTRUMENT

733 RS Chamber				
Name of Equipment	Manufacturer	Model	Serial Number	Calibration Due
Calibration of Field	N/A	Chamber#RS	Ver(Hor)-200805	05/24/2009
Signal Generator	Agilent	E4421B	MY43350597	05/20/2009
Electric Field Probe	AR	FP6001	305650	03/18/2009
RF Power Meter	Boonton	4231A	39601	08/09/2008
Amplifier	AR	100W1000M1	17564	No Calibration Required
Direction Coupler	AR	DC6180A	312189	No Calibration Required
Broadband Antenna	AR	AT1080	311819	No Calibration Required
Thermo-Hygro meter	TFA	N/A	NO.6	11/11/2008
Software	SW1005 Release 1.4.exe			

**NOTE:** 1. The calibration interval of the above test instruments is 12 months and the calibrations are traceable to NML/ROC and NIST/USA.  
 2. N.C.R. = No Calibration required

**8.4.3. TEST PROCEDURE** (please refer to measurement standard or CCS SOP PA-023)

The test procedure was in accordance with EN 61000-4-3

- a) The testing was performed in a fully anechoic chamber. The transmit antenna was located at a distance of 3 meters from the EUT.
- b) The frequency range is swept from 80 MHz to 1000 MHz, with the signal 80% amplitude modulated with a 1kHz sine-wave. The rate of sweep did not exceed  $1.5 \times 10^{-3}$  decade/s, where the frequency range is swept incrementally, the step size was 1% of preceding frequency value.
- c) The dwell time at each frequency shall be not less than the time necessary for the EUT to be able to respond.
- e) The test was performed with the EUT exposed to both vertically and horizontally polarized fields on each of the four sides.

**8.4.4. TEST SETUP**

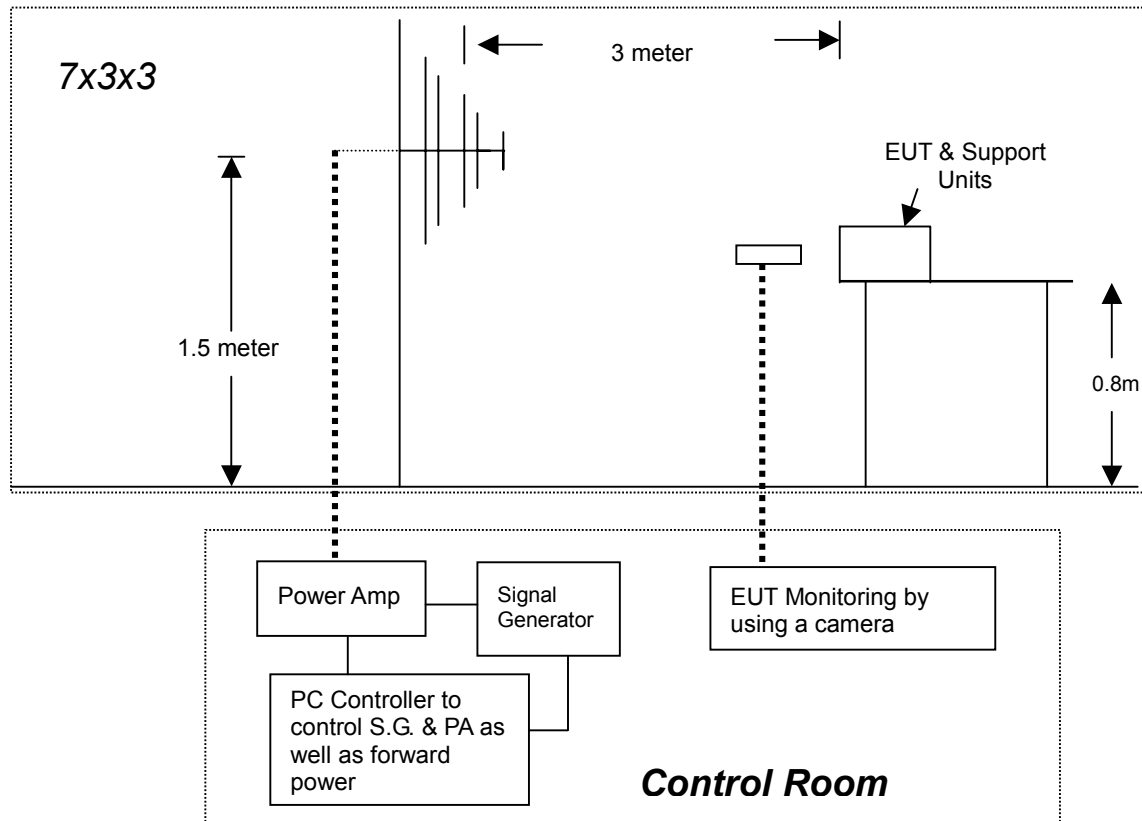

- For the actual test configuration, please refer to the related item – Photographs of the Test Configuration.

**NOTE:**

TABLETOP EQUIPMENT

The EUT installed in a representative system as described in section 7 of EN 61000-4-3 was placed on a non-conductive table 0.8 meters in height. The system under test was connected to the power and signal wire according to relevant installation instructions.

FLOOR STANDING EQUIPMENT

The EUT installed in a representative system as described in section 7 of IEC 61000-4-3 was placed on a non-conductive wood support 0.1 meters in height. The system under test was connected to the power and signal wire according to relevant installation instructions.





8.4.5. TEST RESULTS

Temperature	19°C	Humidity	52% RH
Pressure	1010mbar	Dwell Time	3 sec.
Tested By	Jason Chia	Required Passing Performance	Criterion A

Frequency (MHz)	Polarity	Azimuth	Field Strength (V/m)	Observation	Result
80 ~ 1000	V&H	0	3	Note	PASS
80 ~ 1000	V&H	90	3	Note	PASS
80 ~ 1000	V&H	180	3	Note	PASS
80 ~ 1000	V&H	270	3	Note	PASS

NOTE: There was no change compared with the initial operation during the test.



8.5. ELECTRICAL FAST TRANSIENT (EFT)

8.5.1. TEST SPECIFICATION

<b>Basic Standard:</b>	EN 61000-4-4
<b>Test Voltage:</b>	Power Line: 1 KV Signal/Control Line: 0.5 KV
<b>Polarity:</b>	Positive & Negative
<b>Impulse Frequency:</b>	5 kHz
<b>Impulse Wave-shape:</b>	5/50 ns
<b>Burst Duration:</b>	15 ms
<b>Burst Period:</b>	300 ms
<b>Test Duration:</b>	Not less than 1 min.

8.5.2. TEST INSTRUMENT

Immunity Shield Room				
Name of Equipment	Manufacturer	Model	Serial Number	Calibration Due
EFT Generator	Schaffner	BEST EMC V2.3	200031A024SC	11/06/2008
Capacitive Clamp	Schaffner	N/A	N/A	No Calibration Required
Software	WinBest.exe			

**NOTE:** 1. The calibration interval of the above test instruments is 12 months and the calibrations are traceable to NML/ROC and NIST/USA.  
 2. N.C.R. = No Calibration required

8.5.3. TEST PROCEDURE (please refer to measurement standard or CCS SOP PA-024)

- a) Both positive and negative polarity discharges were applied.
- b) The length of the “hot wire” from the coaxial output of the EFT generator to the terminals on the EUT should not exceed 0.5 meter.
- c) The duration time of each test sequential was 1 minute.
- d) The transient/burst waveform was in accordance with EN 61000-4-4, 5/50ns.

**8.5.4. TEST SETUP**

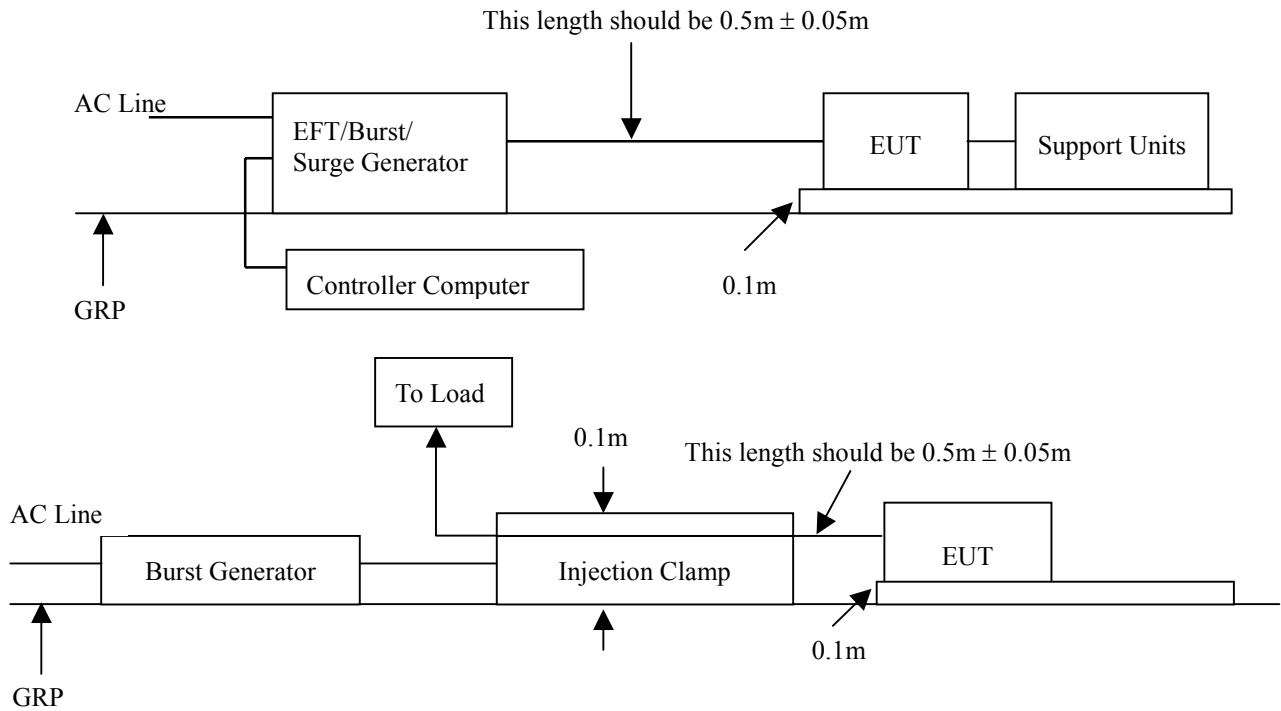

- For the actual test configuration, please refer to the related item – Photographs of the Test Configuration.

**NOTE:**

TABLETOP EQUIPMENT

The configuration consisted of a wooden table (0.1m high) standing on the Ground Reference Plane. The GRP consisted of a sheet of aluminum (at least 0.25mm thick and 2.5m square) connected to the protective grounding system. A minimum distance of 0.5m was provided between the EUT and the walls of the laboratory or any other metallic structure.

FLOOR STANDING EQUIPMENT

The EUT installed in a representative system as described in section 7 of IEC 61000-4-4 and its cables, were isolated from the Ground Reference Plane by an insulating support that is 0.1-meter thick. The GRP consisted of a sheet of aluminum (at least 0.25mm thick and 2.5m square) connected to the protective grounding system.



8.5.5. TEST RESULTS

Temperature	18°C	Humidity	50% RH
Pressure	1010mbar	Tested By	Jason Chia
Required Passing Performance		Criterion B	

Test Point	Polarity	Test Level (KV)	Performance Criterion	Observation	Result
L 1	+/-	1	<input checked="" type="checkbox"/> A <input type="checkbox"/> B	Note <input checked="" type="checkbox"/> 1 <input type="checkbox"/> 2	PASS
L 2	+/-	1	<input checked="" type="checkbox"/> A <input type="checkbox"/> B	Note <input checked="" type="checkbox"/> 1 <input type="checkbox"/> 2	PASS
L 1 - L 2	+/-	1	<input checked="" type="checkbox"/> A <input type="checkbox"/> B	Note <input checked="" type="checkbox"/> 1 <input type="checkbox"/> 2	PASS
PE	+/-	1	<input checked="" type="checkbox"/> A <input type="checkbox"/> B	Note <input checked="" type="checkbox"/> 1 <input type="checkbox"/> 2	PASS
L - PE	+/-	1	<input checked="" type="checkbox"/> A <input type="checkbox"/> B	Note <input checked="" type="checkbox"/> 1 <input type="checkbox"/> 2	PASS
N - PE	+/-	1	<input checked="" type="checkbox"/> A <input type="checkbox"/> B	Note <input checked="" type="checkbox"/> 1 <input type="checkbox"/> 2	PASS
L - N - PE	+/-	1	<input checked="" type="checkbox"/> A <input type="checkbox"/> B	Note <input checked="" type="checkbox"/> 1 <input type="checkbox"/> 2	PASS
RJ45	+/-	0.5	<input checked="" type="checkbox"/> A <input type="checkbox"/> B	Note <input checked="" type="checkbox"/> 1 <input type="checkbox"/> 2	PASS

NOTE: 1. There was no change compared with initial operation during the test.



8.6. SURGE IMMUNITY TEST

8.6.1. TEST SPECIFICATION

<b>Basic Standard:</b>	EN 61000-4-5
<b>Wave-Shape:</b>	Combination Wave 1.2/50 us Open Circuit Voltage 8/20 us Short Circuit Current
<b>Test Voltage:</b>	Power Line ~ Line to Line: 1 KV; Line to Ground: 2 KV
<b>Surge Input/Output:</b>	Power Line: L1-L2 / L1-PE / L2-PE
<b>Generator Source Impedance:</b>	2 ohm between networks 12 ohm between network and ground
<b>Polarity:</b>	Positive/Negative
<b>Phase Angle:</b>	0° / 90° / 180° / 270°
<b>Pulse Repetition Rate:</b>	1 time / min. (maximum)
<b>Number of Tests:</b>	5 positive and 5 negative at selected points

8.6.2. TEST INSTRUMENT

Immunity Shield Room				
Name of Equipment	Manufacturer	Model	Serial Number	Calibration Due
Surger Generator	Schaffner	BEST EMC V2.3	200031A024SC	11/06/2008
Signal and Data Lines Coupling Network	Schaffner	CDN118	19328	No Calibration Required
Software	WinBest.exe			

**NOTE:** 1. The calibration interval of the above test instruments is 12 months and the calibrations are traceable to NML/ROC and NIST/USA.  
2. N.C.R. = No Calibration required

**8.6.3. TEST PROCEDURE** (please refer to measurement standard or CCS SOP PA-025)

## a) For EUT power supply:

The surge is applied to the EUT power supply terminals via the capacitive coupling network. Decoupling networks are required in order to avoid possible adverse effects on equipment not under test that may be powered by the same lines, and to provide sufficient decoupling impedance to the surge wave. The power cord between the EUT and the coupling/decoupling networks was shorter than 2 meters in length.

## b) For test applied to unshielded un-symmetrically operated interconnection lines of EUT:

The surge was applied to the lines via the capacitive coupling. The coupling / decoupling networks didn't influence the specified functional conditions of the EUT. The interconnection line between the EUT and the coupling/decoupling networks was shorter than 2 meters in length.

## c) For test applied to unshielded symmetrically operated interconnection / telecommunication lines of EUT:

The surge was applied to the lines via gas arrestors coupling. Test levels below the ignition point of the coupling arrestor were not specified. The interconnection line between the EUT and the coupling/decoupling networks was shorter than 2 meters in length.

#### 8.6.4. TEST SETUP

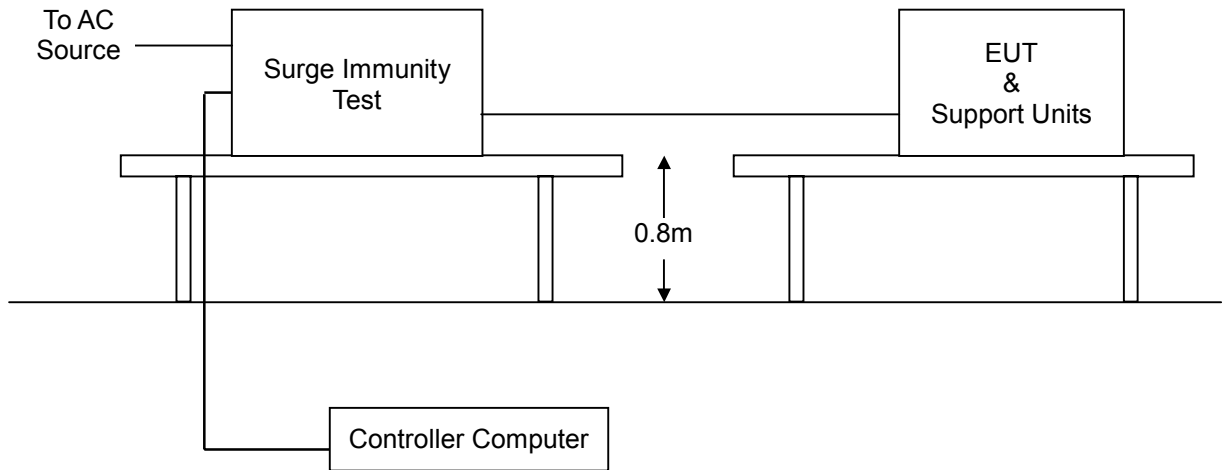

- For the actual test configuration, please refer to the related item – Photographs of the Test Configuration.



8.6.5. TEST RESULTS

Temperature	18°C	Humidity	50% RH
Pressure	1010mbar	Tested By	Jason Chia
Required Passing Performance		Criterion B	

Test Point	Polarity	Test Level (KV)	Performance Criterion	Observation	Result
L1 - L2	+/-	1	<input checked="" type="checkbox"/> A <input type="checkbox"/> B	Note <input checked="" type="checkbox"/> 1 <input type="checkbox"/> 2	PASS
L1 - PE	+/-	2	<input checked="" type="checkbox"/> A <input type="checkbox"/> B	Note <input checked="" type="checkbox"/> 1 <input type="checkbox"/> 2	PASS
L2 - PE	+/-	2	<input checked="" type="checkbox"/> A <input type="checkbox"/> B	Note <input checked="" type="checkbox"/> 1 <input type="checkbox"/> 2	PASS

**NOTE:** 1. (a) There was no change compared with initial operation during the test.  
 (b) Where normal functioning of LAN can't be achieved because of the impact of CDN on the EUT, no test be required.





8.7. CONDUCTED RADIO FREQUENCY DISTURBANCES (CS)

8.7.1. TEST SPECIFICATION

<b>Basic Standard:</b>	EN 61000-4-6
<b>Frequency Range:</b>	0.15 MHz ~ 80 MHz
<b>Field Strength:</b>	3 Vrms
<b>Modulation:</b>	1kHz Sine Wave, 80%, AM Modulation
<b>Frequency Step:</b>	1 % of preceding frequency value
<b>Coupled cable:</b>	Power Mains, Unshielded; RJ45 Line, Unshielded
<b>Coupling device:</b>	CDN-M3 (3 wires), CDN-T4

8.7.2. TEST INSTRUMENT

CS Room				
Name of Equipment	Manufacturer	Model	Serial Number	Calibration Due
RF Generator	Schaffner	NSG 2070-1	1061	07/30/2008
CDN	Schaffner	CDN M316	19600	07/29/2008
CDN	Schaffner	CDN M216	19294	07/29/2008
EM Clamp	Schaffner	KEMZ 801	19227	03/04/2009
CDN	Schaffner	CDN T002	15881	01/06/2009
CDN	FCC	FCC-801-T8-RJ45	04025	07/04/2008
Attenuator	Schaffner	INA2070-1	2061	No Calibration Required
CDN	FCC	FCC-801-T4-RJ45	04031	07/29/2008
Software	Win2070.exe			

**NOTE:** 1. The calibration interval of the above test instruments is 12 months and the calibrations are traceable to NML/ROC and NIST/USA.  
 2. N.C.R. = No Calibration required



**8.7.3. TEST PROCEDURE** (please refer to measurement standard or CCS SOP PA-026)

The EUT shall be tested within its intended operating and climatic conditions.

The test shall be performed with the test generator connected to each of the coupling and decoupling devices in turn, while the other non-excited RF input ports of the coupling devices are terminated by a 50-ohm load resistor.

The frequency range was swept from 150 kHz to 80 MHz, using the signal level established during the setting process and with a disturbance signal of 80 % amplitude. The signal was modulated with a 1 kHz sine wave, pausing to adjust the RF signal level or the switch coupling devices as necessary. The sweep rate was  $1.5 \times 10^{-3}$  decades/s. Where the frequency range is swept incrementally, the step size was 1 % of preceding frequency value from 150 kHz to 80 MHz.

The dwell time at each frequency was less than the time necessary for the EUT to be exercised, and able to respond. Sensitive frequencies such as clock frequency(ies) and harmonics or frequencies of dominant interest, was analyzed separately.

Attempts were made to fully exercise the EUT during testing, and to fully interrogate all exercise modes selected for susceptibility.

8.7.4. TEST SETUP

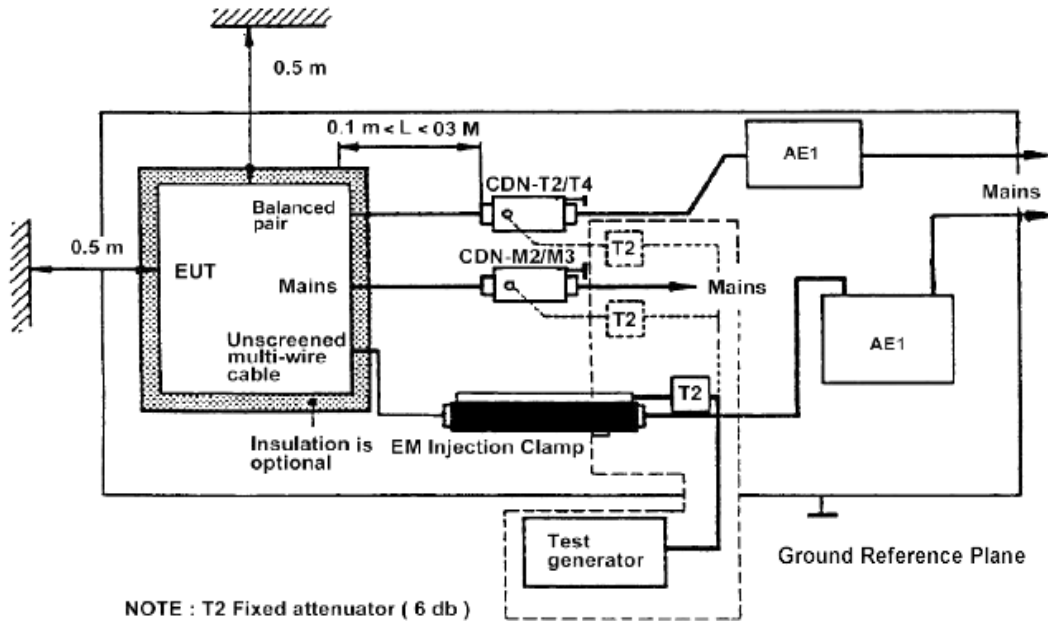

- Note: 1. The EUT is setup 0.1m above Ground Reference Plane*  
*2. The CDNs and / or EM clamp used for real test depends on ports and cables configuration of EUT.*

- For the actual test configuration, please refer to the related item – Photographs of the Test Configuration.

**NOTE:**

TABLE-TOP AND FLOOR-STANDING EQUIPMENT

The equipment to be tested is placed on an insulating support of 0.1 meters height above a ground reference plane. All relevant cables shall be provided with the appropriate coupling and decoupling devices at a distance between 0.1 meters and 0.3 meters from the projected geometry of the EUT on the ground reference plane.



8.7.5. TEST RESULTS

Temperature	19°C	Humidity	52% RH
Pressure	1010mbar	Tested By	Jason Chia
Required Passing Performance		Criterion A	

Frequency Band (MHz)	Field Strength (Vrms)	Cable	Injection Method	Performance Criterion	Observation	Result
0.15 ~ 80	3	AC Power Line (0.3m)	CDN-M3	<input checked="" type="checkbox"/> A <input type="checkbox"/> B	Note <input checked="" type="checkbox"/> 1 <input type="checkbox"/> 2	PASS
0.15 ~ 80	3	RJ 45 Line (0.3m)	CDN-T4	<input checked="" type="checkbox"/> A <input type="checkbox"/> B	Note <input checked="" type="checkbox"/> 1 <input type="checkbox"/> 2	PASS

NOTE: 1. There was no change compared with initial operation during the test.



8.8. POWER FREQUENCY MAGNETIC FIELD

8.8.1. TEST SPECIFICATION

<b>Basic Standard:</b>	EN 61000-4-8
<b>Frequency Range:</b>	50Hz
<b>Field Strength:</b>	1 A/m
<b>Observation Time:</b>	1 minute
<b>Inductance Coil:</b>	Rectangular type, 1mx1m

8.8.2. TEST INSTRUMENT

Immunity Shield Room				
Name of Equipment	Manufacturer	Model	Serial Number	Calibration Due
Induction Coil Interface	Schaffner	INA 21141	6009	No Calibration Required
5KVA AC Power Source	Schaffner	NSG 1007	55131	No Calibration Required
TRMS Clamp Meter	CHY	932C	995000273	06/10/2009
Magnetic Field Meter	Sypris	4080	0247	03/17/2009

**NOTE:** 1. The calibration interval of the above test instruments is 12 months and the calibrations are traceable to NML/ROC and NIST/USA.  
 2. N.C.R. = No Calibration required

8.8.3. TEST PROCEDURE (please refer to measurement standard or CCS SOP PA-027)

- a. The equipment is configured and connected to satisfy its functional requirements. It shall be placed on the GRP with the interposition of a 0.1m-thick insulating support.
- b. The equipment cabinets shall be connected to the safety earth directly on the GRP via the earth terminal of the EUT.
- c. The power supply, input and output circuits shall be connected to the sources of power supply, control and signal.
- d. The cables supplied or recommended by the equipment manufacturer shall be used. 1 meter of all cables used shall be exposed to the magnetic field.

**8.8.4. TEST SETUP**

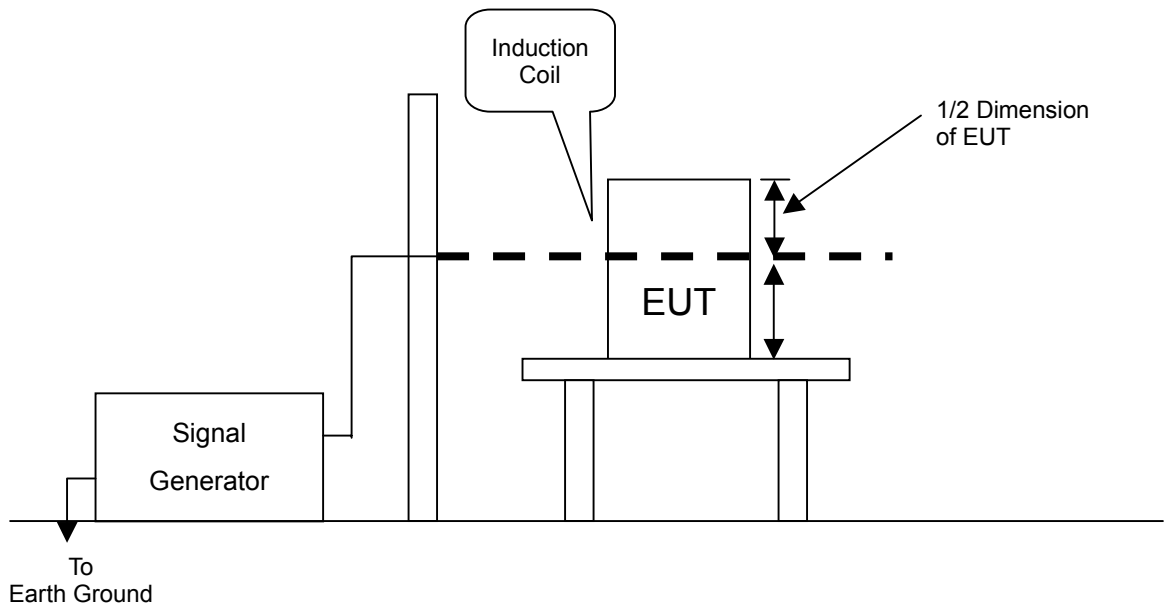

- For the actual test configuration, please refer to the related item – Photographs of the Test Configuration.

**NOTE:**

TABLETOP EQUIPMENT

The equipment shall be subjected to the test magnetic field by using the induction coil of standard dimension (1 m x 1 m). The induction coil shall then be rotated by 90 degrees in order to expose the EUT to the test field with different orientations.

FLOOR-STANDING EQUIPMENT

The equipment shall be subjected to the test magnetic field by using induction coils of suitable dimensions. The test shall be repeated by moving and shifting the induction coils, in order to test the whole volume of the EUT for each orthogonal direction. The test shall be repeated with the coil shifted to different positions along the side of the EUT, in steps corresponding to 50 % of the shortest side of the coil. The induction coil shall then be rotated by 90 degrees in order to expose the EUT to the test field with different orientations.



8.8.5. TEST RESULTS

Temperature	N/A	Humidity	N/A
Pressure	N/A	Tested By	N/A
Required Passing Performance		Criterion A	

DIRECTION	Field Strength (A/m)	Performance Criterion	OBSERVATION	RESULTS
X	1	A	Note	N/A
Y	1	A	Note	N/A
Z	1	A	Note	N/A

**NOTE:** The EUT is not containing any component that is susceptible to a 50 Hz or 60 Hz magnetic field. Therefore, this requirement is not applicable to the EUT.



### 8.9. VOLTAGE DIP & VOLTAGE INTERRUPTIONS

#### 8.9.1. TEST SPECIFICATION

**Basic Standard:** EN 61000-4-11

**Test duration time:** Minimum three test events in sequence

**Interval between event:** Minimum 10 seconds

**Phase Angle:** 0° / 45° / 90° / 135° / 180° / 225° / 270° / 315° / 360°

**Test cycle:** 3 times

#### 8.9.2. TEST INSTRUMENT

Immunity shielded room				
Name of Equipment	Manufacturer	Model	Serial Number	Calibration Due
Dips/Interruption/Variations Tester	Schaffner	BEST EMC V2.3	200031A024SC	11/06/2008
Software	WinBest.exe			

**NOTE:** 1. The calibration interval of the above test instruments is 12 months and the calibrations are traceable to NML/ROC and NIST/USA.  
 2. N.C.R. = No Calibration required

#### 8.9.3. TEST PROCEDURE (please refer to measurement standard or CCS SOP PA-028)

1. The EUT and support units were located on a wooden table, 0.8 m away from ground floor.
2. Setting the parameter of tests and then perform the test software of test simulator.
3. Conditions changes to occur at 0 degree crossover point of the voltage waveform.
4. Recording the test result in test record form.



### 8.9.4. TEST SETUP

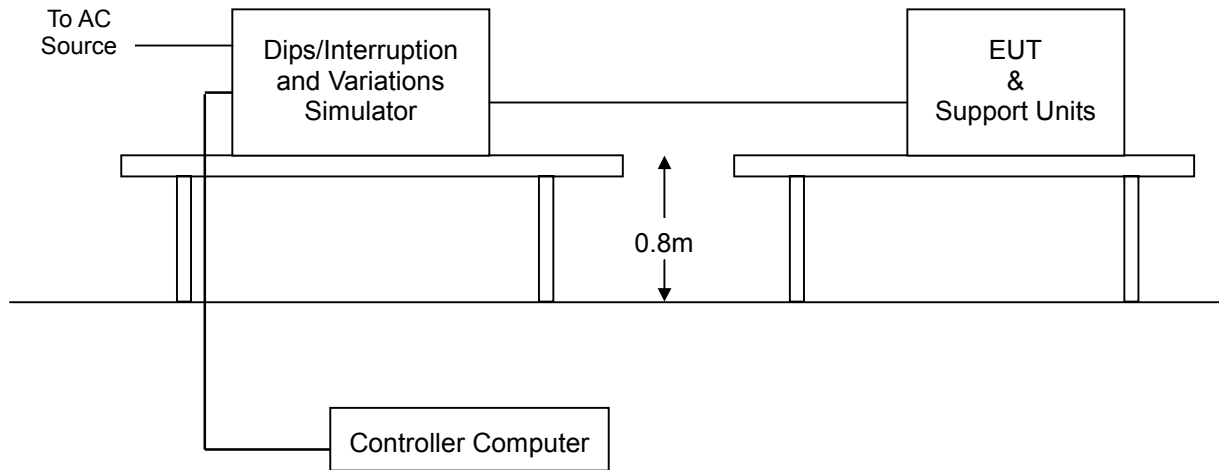

- For the actual test configuration, please refer to the related item – Photographs of the Test Configuration.



8.9.5. TEST RESULTS

Temperature	18°C	Humidity	50% RH
Pressure	1010mbar	Tested By	Jason Chia
Required Passing Performance	<b>Criterion B: &gt;95% reduction 0.5 period</b> <b>Criterion C: 30% reduction 25 period &amp; &gt;95% reduction 250 period</b>		

Test Power: 230Vac, 50Hz				
Voltage (% Reduction)	Duration (Period)	Performance Criterion	Observation	Test Result
>95	0.5	<input checked="" type="checkbox"/> A <input type="checkbox"/> B <input type="checkbox"/> C	Note <input checked="" type="checkbox"/> 1 <input type="checkbox"/> 2	PASS
30	25	<input checked="" type="checkbox"/> A <input type="checkbox"/> B <input type="checkbox"/> C	Note <input checked="" type="checkbox"/> 1 <input type="checkbox"/> 2	PASS
>95	250	<input type="checkbox"/> A <input type="checkbox"/> B <input checked="" type="checkbox"/> C	Note <input type="checkbox"/> 1 <input checked="" type="checkbox"/> 2	PASS

**NOTE:** 1. There was no change compared with initial operation during and after the test. No unintentional response was found during the test.

2. EUT shut down, but EUT can be auto recovered after power on.

## **9 PHOTOGRAPHS OF THE TEST CONFIGURATION CONDUCTED EMISSION TEST**



**CONDUCTED EMISSION TEST AT TELECOMMUNICATION PORTS**  
**RJ45 Telecom Port with ISN (10Mbps & 100Mbps)**



### **RADIATED EMISSION TEST**



**Harmonic & Flick Test**

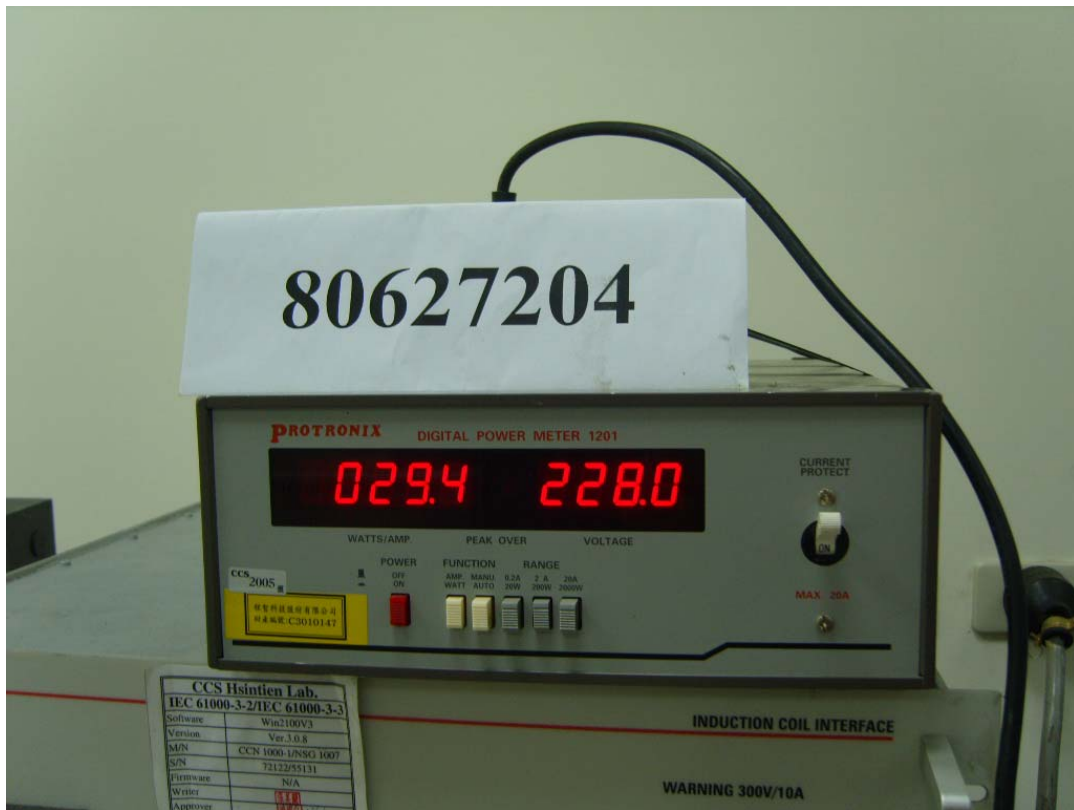

ESD Test



RS Test

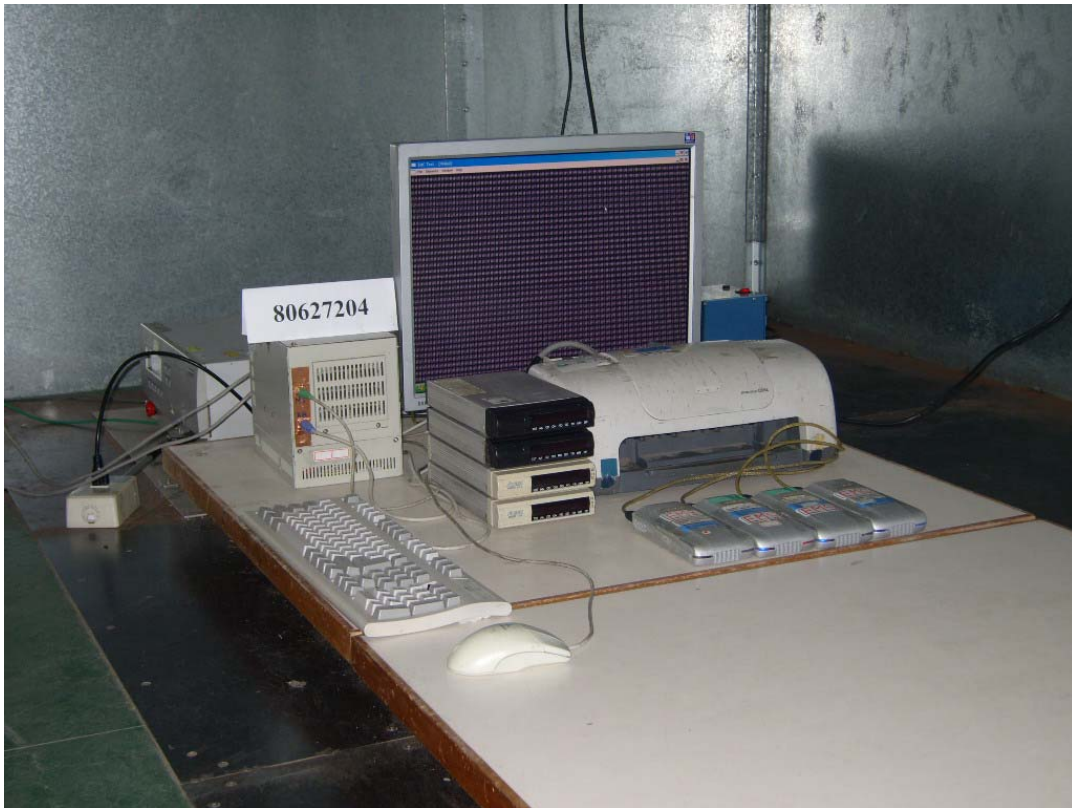

**EFT Test****EFT For I/O Test**



**Surge Test**



**CS Test**

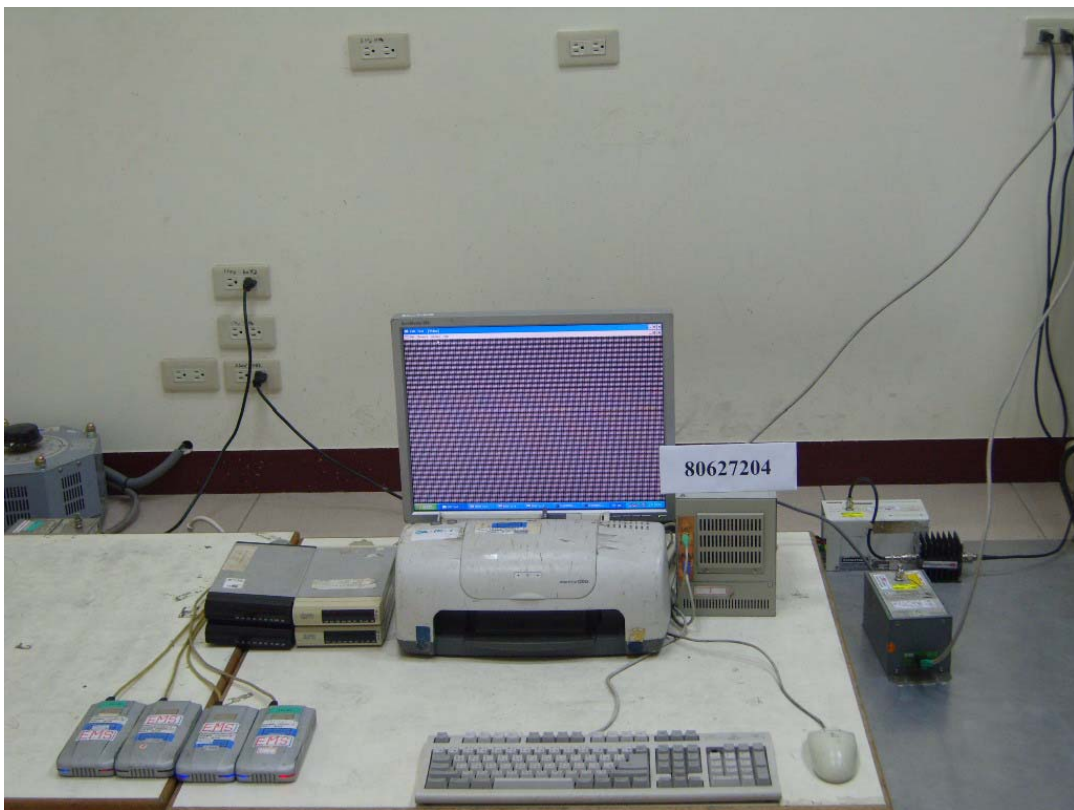

**CS For I/O Test**

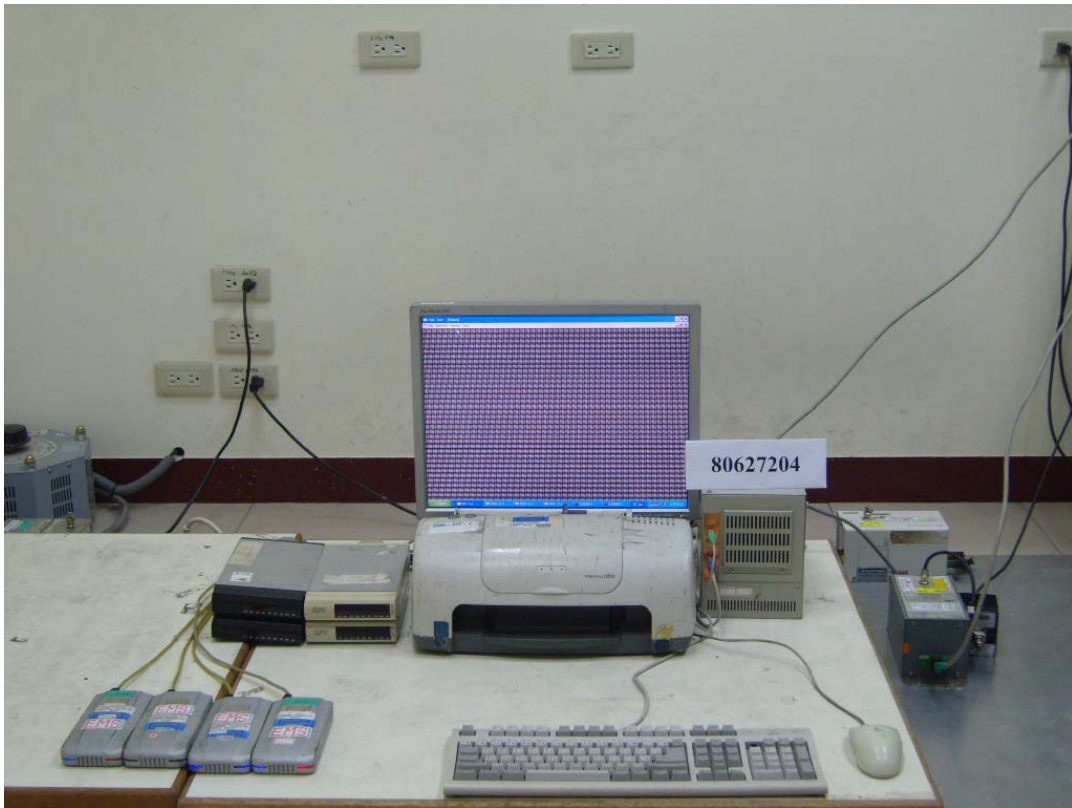

**Voltage Dip Test**

