



CE EMC

TEST REPORT

For

PC/104 CPU Module

Model: PFM-532I

Trade Name: AAEON

Issued to

AAEON Technology Inc.

**5F, No. 135, Lane 235, Pao Chiao Rd., Hsin-Tien City,
Taipei, Taiwan, R.O.C.**

Issued by



**Compliance Certification Services Inc.
Hsintien Lab.**

**No. 165, Chungsen Road, Hsintien City
Taipei Hsien, Taiwan**

TEL: (02) 2217-0894

FAX: (02) 2217-1029



Note: This report shall not be reproduced except in full, without the written approval of Compliance Certification Services Inc. Ltd. This document may be altered or revised by Compliance Certification Services Inc. personnel only, and shall be noted in the revision section of the document.



TABLE OF CONTENTS

1	TEST RESULT CERTIFICATION	3
2	EUT DESCRIPTION	4
3	TEST METHODOLOGY.....	5
3.1	EUT SYSTEM OPERATION.....	5
3.2	DECISION OF FINAL TEST MODE	5
4	SETUP OF EQUIPMENT UNDER TEST	6
5	FACILITIES AND ACCREDITATIONS.....	7
5.1	FACILITIES.....	7
5.2	LABORATORY ACCREDITATIONS AND LISTINGS	7
6	INSTRUMENT AND CALIBRATION	8
6.1	MEASURING INSTRUMENT CALIBRATION	8
6.2	TEST AND MEASUREMENT EQUIPMENT	8
7	LINE CONDUCTED & RADIATED EMISSION TEST.....	11
7.1	LIMIT	11
7.2	TEST PROCEDURE OF LINE CONDUCTED EMISSION	12
7.3	TEST PROCEDURE OF COMMON MODE CONDUCTED EMISSION FOR TELECOMMUNICATION PORT	13
7.4	TEST PROCEDURE OF RADIATED EMISSION	14
7.5	TEST RESULTS	16
8	POWER HARMONICS TEST.....	18
9	POWER VOLTAGE FLUCTUATION / FLICKER TEST	20
10	ELECTROSTATIC DISCHARGE (ESD) IMMUNITY TEST	22
11	RADIATED ELECTROMAGNETIC FIELD IMMUNITY TEST.....	28
12	FAST TRANSIENTS/BURST IMMUNITY TEST.....	31
13	SURGE IMMUNITY TEST	33
14	CONDUCTED DISTURBANCE/INDUCED RADIO-FREQUENCY FIELD IMMUNITY TEST.....	35
15	POWER FREQUENCY MAGNETIC FIELD IMMUNITY TEST.....	37
16	VOLTAGE DIPS / SHORT INTERRUPTIONS.....	39
	APPENDIX I - PHOTOGRAPHS OF TEST SETUP	41
	APPENDIX II – TEST RESULT OF EN 61000-3-2/-3	49



1 TEST RESULT CERTIFICATION

Applicant: **AAEON Technology Inc.**
5F, No. 135, Lane 235, Pao Chiao Rd., Hsin-Tien City,
Taipei, Taiwan, R.O.C.

Manufacturer: **AAEON Technology Inc.**
5F, No. 135, Lane 235, Pao Chiao Rd., Hsin-Tien City,
Taipei, Taiwan, R.O.C.

Equipment Under Test: PC/104 CPU Module

Trade Name: AAEON

Model: PFM-532I

Detailed EUT Description: See Item 2 of this report

Date of Test: November 7, 2005 ~ November 17, 2005

Applicable Standard	Class/Limit/Criterion	Test Result
EN 55022: 1998 + A1: 2000 + A2: 2003	Class B	No non-compliance noted
EN 61000-3-2: 2000	Class D	No non-compliance noted
EN 61000-3-3: 1995 + A1: 2001	Limit	No non-compliance noted
EN 55024: 1998 + A1: 2001 + A2: 2003		
IEC 61000-4-2: 1995 + A1: 1998 + A2: 2000	Criterion B	No non-compliance noted
IEC 61000-4-3: 2002 + A1: 2002	Criterion A	No non-compliance noted
IEC 61000-4-4: 1995 + A1: 2000 + A2: 2001	Criterion B	No non-compliance noted
IEC 61000-4-5: 1995 + A1: 2000	Criterion B	No non-compliance noted
IEC 61000-4-6: 1996 + A1: 2000	Criterion A	No non-compliance noted
IEC 61000-4-8: 1993 + A1: 2000	Criterion A	N/A
IEC 61000-4-11: 1994 + A1: 2000	Criterion B/C/C	No non-compliance noted
Deviation from Applicable Standard		
None		

The above equipment was tested by Compliance Certification Services Inc. for compliance with the requirements set forth in the EMC Directive 89/336/EMC and the technical standards mentioned above. The results of testing in this report apply only to the product/system, which was tested. Other similar equipment will not necessarily produce the same results due to production tolerance and measurement uncertainties.

Approved by:

David Wang
Manager of Hsintien Laboratory
Compliance Certification Services Inc.

Reviewed by:

Vince Chiang
Assistant Manager of Hsintien Laboratory
Compliance Certification Services Inc.



2 EUT DESCRIPTION

Product	PC/104 CPU Module
Trade Name	AAEON
Model	PFM-532I
Housing Type	Metal case
EUT Power Rating	5VDC from Power Supply
AC Power During Test	230VAC / 50Hz to Power Supply
Power Supply Manufacturer	Enhance
Power Supply Model Number	ENH-0620 / Input: 100V-240V(AC)
AC Power Cord Type	Unshielded, 1.8m (Detachable)
OSC/Clock Frequencies	14.31818MHz; 25MHz; 32.768kHz

I/O PORT OF EUT

I/O PORT TYPE	Q'TY	TESTED WITH
1). PIO Port	1	1
2). SIO Port	2	2
3). PS/2 Keyboard Port	1	1
4). PS/2 Mouse Port	1	1
5). VIDEO-OUT Port (VGA)	1	1
6). LAN Port	1	1

Note: Client consigns only one model sample (Model Number is PFM-532I) to test.



3 TEST METHODOLOGY

3.1 EUT SYSTEM OPERATION

- 1.Windows 98 boots system.
- 2.Run Emctest.exe to activate all peripherals and display “H” pattern on monitor screen.
- 3.Run Winemc.exe then choose “C:/ & D:/ & E:/ & F:/” to test EUT.
- 4.Press the start menu, select executive and type ping 192.168.0.2 -t (EUT), ping 192.168.0.1 -t (Server PC).

Note: Test program is self-repeating throughout the test.

3.2 DECISION OF FINAL TEST MODE

1. The following test mode were scanned during the preliminary test:

Mode(s):

1.	1024X768 MODE
2.	800X600 MODE

2. After the preliminary scan, the following test mode was found to produce the highest emission level.

Conduction: Mode 1

Radiation: Mode 1

Then, the EUT configuration and cable configuration of the above highest emission mode was chosen for all final test items.



4 SETUP OF EQUIPMENT UNDER TEST

Setup Diagram

See test photographs attached in Appendix I for the actual connections between EUT and support equipment.

Support Equipment

EUT Devices:

No	Equipment	Model	Trade Name
1	Power Supply	ENH-0620	Enhance
2	CPU (133MHz)	STPC-DX2	ST
3	Memory (32MB)	HY57V6432DTP-6	Hynix
4	HDD (30GB)	Firedall 3	Maxtor

Peripherals Devices:

No	Equipment	Model	Serial No.	FCC/ BSMI ID	Trade Name	Data Cable	Power Cord
1	PS/2 Mouse	M071KC	443029438	DoC BSMI: R41108	DELL	Shielded, 1.8m	N/A
2	PS/2 Keyboard	SK-8110	N/A	DoC BSMI: T3A002	DELL	Shielded, 1.8m	N/A
3	Modem	5JEG4033MKO	N/A	5RJTAI-35500-M5-E	TOP-SOLUTION	Shielded, 1.8m	Unshielded, 1.8m
4	Modem	5JEG4033MKO	N/A	5RJTAI-35500-M5-E	TOP-SOLUTION	Shielded, 1.8m	Unshielded, 1.8m
5	Monitor	710V	GS17H9NXA05853A	DoC BSMI: R33475	SAMSUNG	Shielded, 1.8m with two cores	Unshielded, 1.8m
6	Printer	C60	DR3K039402	BSMI ID: 3902E006	EPSON	Shielded, 1.8m	Unshielded, 1.8m
7	Server PC	M285	RD49R-7YTJR-B3C4K-G2JQX-DD3CG	DoC BSMI: R31259	LEO	Unshielded, 20m	Unshielded, 1.8m with a core

Note: All the above equipment/cables were placed in worse case positions to maximize emission signals during emission test. Grounding: Grounding was in accordance with the manufacturer's requirements and conditions for the intended use.

5 FACILITIES AND ACCREDITATIONS







5.1 FACILITIES

All measurement facilities used to collect the measurement data are located at CCS Taiwan Hsintien Lab at No. 165, Chunghsen Road, Hsintien City, Taipei Hsien, Taiwan.

The measurement facilities are constructed in conformance with the requirements of CISPR 16-1, ANSI C63.4 and other equivalent standards.

5.2 LABORATORY ACCREDITATIONS AND LISTINGS

The test facilities used to perform Electromagnetic compatibility tests are registered or accredited by the organizations listed in the following table which includes the recognized scope specifically.

Country	Agency	Scope of Accreditation	Logo
USA	A2LA	CFR 47, FCC Part 15/18 using ANSI 63.4; AS/NZS 3548; VCCI V3; CNS 13438; CNS 13439; CNS 13783; CNS 14115; CISPR 11/EN 55011; CISPR 14-1/EN 55014-1; CISPR 15/EN 55015; CISPR 22/EN 55022; EN 50081-1/EN 61000-6-3; EN 50082-1/EN 61000-6-4; IEC/EN 61000-4-2, IEC/EN 61000-4-3, IEC/EN 61000-4-4, IEC/EN 61000-4-5, IEC/EN 61000-4-6, IEC/EN 61000-4-8, IEC/EN 61000-4-11, IEC/EN 61000-3-2, IEC/EN 61000-3-3; CISPR 24/EN 55024; CISPR 14-2/EN 55014-2; EN 50081-2/EN 61000-6-1; EN 50082-2/EN 61000-6-2.	 824.01
USA	FCC	3/10 meter Open Area Test Sites to perform FCC Part 15/18 measurements	 250366
Japan	VCCI	3/10 meter Open Area Test Sites and Line Conducted Test Room to perform conducted/radiated measurements	 R-1434/1630~4 C-1511/1882
Norway	NEMKO	EN 50081-1/2, EN 50082-1/2, IEC 61000-6-1/2/3/4, EN 50091-2, EN 50130-4, EN 55011, EN 55013, EN 55014-1/2, EN 55015, EN 55022, EN 55024, EN 61000-3-2/3, EN 61326-1, IEC 61000-4-2/3/4/5/6/8/11, Cisp16-1/2/3/4	 ELA 103
Taiwan	CNLA	47 CFR FCC Part 15 Subpart B, EN 61000-3-2, EN 61000-3-3, CNS 13439, CNS 13783-1, CNS 13438, AS/NZS 3548, VCCI, CNS 13022-1/2/3, EN 55022, EN 55013, EN 55014-1, EN 61000-4-2/3/4/5/6/8/11, ENV 50204, ENV 50141, ENV 50142	 1108 ILAC MRA
Taiwan	BSMI	CNS 13438, CNS 13783-1, CNS 13439	 SL2-IN-E-0005 SL2-A1-E-0005 SL2-R1-E-0005 SL2-R2-E-0005
Canada	Industry Canada	RSS212, Issue 1	 IC 5742

Note: No part of this report may be used to claim or imply product endorsement by CNLA, A2LA or other government agency.



6 INSTRUMENT AND CALIBRATION

6.1 MEASURING INSTRUMENT CALIBRATION

The measuring equipment utilized to perform the tests documented in this report has been calibrated once a year or in accordance with the manufacturer's recommendations, and is traceable to recognized national standards.

6.2 TEST AND MEASUREMENT EQUIPMENT

The following list contains measurement equipment used for testing. The equipment conforms to the requirement of CISPR 16-1, ANSI C63.2 and other required standards.

Calibration of all test and measurement, including any accessories that may effect such calibration, is checked frequently to ensure the accuracy. Adjustments are made and correction factors are applied in accordance with the instructions contained in the respective manual.

Equipment Used for Emission Measurement

Open Area Test Site # I				
EQUIPMENT	MFR	MODEL	SERIAL NUMBER	CAL. DUE
SITE NSA	CCS	I Site	N/A	10/14/2006
MEASURE RECEIVER	SCHAFFNER	SCR3501	338	06/27/2006
SPECTRUM ANALYZER	ADVANTEST	R3132	120900008	No Calibration Required
ANTENNA	SCHAFFNER	CBL 6112B	2809	09/23/2006
AMPLIFIER	SCHAFFNER	CPA9231A	3626	10/08/2006
CABLE	BELDEN	9913	N-TYPE #12	02/18/2006
ATTENUATOR	MCL	UNAT-6	AT06-3	10/08/2006
THERMO-HYGRO METER	TFA	N/A	NO.2	11/02/2006
DECOUPLING NETWORK	FCC	F-201-DCN-5-6MM	22, 24	08/24/2006

Note: The measurement uncertainty is less than +/- 3.36dB, which is evaluated as per the NAMAS NIS 81 and CISPR/A/291/CDV.

Conducted Emission Test Site # A				
EQUIPMENT	MFR	MODEL	SERIAL NUMBER	CAL. DUE
TEST RECEIVER	R&S	ESHS20	840455/006	02/17/2006
LISN (EUT)	SCHWARZBECK	NSLK 8127	8127382	01/03/2006
LISN	SOLAR	8012-50-R-24-BNC	8305114	01/03/2006
BNC CABLE	JYE BAO	RG-223/U	BNC A2	10/08/2006
THERMO-HYGRO METER	TOP	HA-202	9303-1	03/02/2006
4-Wire ISN	R&S	ENY41	100006	07/06/2006
2-Wire ISN	R&S	ENY22	100020	07/06/2006

Note: The measurement uncertainty is less than +/- 2.83dB, which is evaluated as per the NAMAS NIS 81 and CISPR/A/291/CDV.



Power Harmonic & Voltage Fluctuation/Flicker Test Site (EN 61000-3-2&-3-3)			
Manufacturer/Type	Model No.	Serial No.	Cal. Due
Schaffner / Signal Conditioning Unit	CCN 1000-1	72122	12/05/2005
Schaffner / 5KVA AC Power Source	NSG 1007	55131	No Calibration Required

Equipment Used for Immunity Measurement

ESD Test Site (EN 61000-4-2)			
Manufacturer/Type	Model No.	Serial No.	Cal. Due
Schaffner / ESD Simulator	NSG 438	129	04/20/2006
Sato / Aneroid Barometer	7610-20	89090	08/29/2006
TOP / Thermo-Hygro meter	HA-202	9303-1	03/02/2006

Radiated Electromagnetic Field Immunity Test Site (EN 61000-4-3)			
Manufacturer/Type	Model No.	Serial No.	Cal. Due
Calibration of Field	Chamber#RS	RS3H-7 / RS3V-7	07/01/2006
Agilent / Signal Generator	E4421B	MY43350597	05/16/2006
AR / Electric Field Probe	FP6001	305650	02/03/2006
Boonton / RF Voltmeter	9200B	328001AE	02/23/2006
BNC / Function Generator	625A	25451	02/17/2006
AR / Amplifier	100W1000M1	17564	No Calibration Required
Werlatone Inc. / Direction Coupler	C2630	4121	No Calibration Required
Frankonia / Broadband Antenna	BTA-M	030001M	No Calibration Required
TOP / Thermo-Hygro meter	HA-202	9303-2	03/02/2006

Fast Transients/Burst Test Site (EN 61000-4-4)			
Manufacturer/Type	Model No.	Serial No.	Cal. Due
Schaffner / EFT Generator	BEST EMC V2.3	200031A024SC	11/07/2006
Schaffner / Capacitive Clamp	N/A	N/A	No Calibration Required



Surge Immunity Test Site (EN 61000-4-5)			
Manufacturer/Type	Model No.	Serial No.	Cal. Due
Schaffner / Surger Generator	BEST EMC V2.3	200031A024SC	11/07/2006
Schaffner / Signal and Data Lines Coupling Network	CDN118	19328	No Calibration Required

CS test (EN 61000-4-6)			
Manufacturer/Type	Model No.	Serial No.	Cal. Due
Schaffner / RF Generator	NSG 2070-1	1061	08/03/2006
Schaffner / CDN	CDN M316	19600	08/02/2006
Schaffner / CDN	CDN M216	19294	08/02/2006
FCC / CDN	FCC-801-M3-16A	99122	08/02/2006
Schaffner / EM Clamp	KEMZ 801	19227	02/23/2006
Schaffner / CDN	CDN T002	15881	01/13/2006
FCC / CDN	FCC-801-T8-RJ45	04025	06/23/2006
Schaffner / Attenuator	INA2070-1	2061	No Calibration Required
FCC / CDN	FCC-801-T4-RJ45	04031	08/02/2006

Power Frequency Magnetic Field Immunity test (EN 61000-4-8)			
Manufacturer/Type	Model No.	Serial No.	Cal. Due
Schaffner / Induction Coil Interface	INA 21141	6009	No Calibration Required
Schaffner / 5KVA AC Power Source	NSG 1007	55131	No Calibration Required
CHY/ TRMS Clamp Meter	932C	2K0900285	10/16/2006
Sypris / Magnetic Field Meter	4080	0247	01/19/2006

Voltage Dips/Short Interruption and Voltage Variation Immunity test (EN 61000-4-11)			
Manufacturer/Type	Model No.	Serial No.	Cal. Due
Schaffner / Dips/Interruption/Variations Tester	BEST EMC V2.3	200031A024SC	11/07/2006
Protronix / Digital Power Meter	1201	201091	08/24/2006



7 LINE CONDUCTED & RADIATED EMISSION TEST

7.1 LIMIT

Maximum permissible level of Line Conducted Emission

FREQUENCY (MHz)	Class A (dBuV)		Class B (dBuV)	
	Quasi-peak	Average	Quasi-peak	Average
0.15 - 0.5	79	66	66 - 56	56 - 46
0.50 - 5.0	73	60	56	46
5.0 - 30.0	73	60	60	50

Note: The lower limit shall apply at the transition frequency.

Maximum permissible level of Common Mode Conducted Emission (Telecommunication Ports)

CLASS A

FREQUENCY (MHz)	Voltage Limit (dBuV)		Current Limit (dBuA)	
	Quasi-peak	Average	Quasi-peak	Average
0.15 - 0.5	97 - 87	84 - 74	53 - 43	40 - 30
0.5 - 30.0	87	74	43	30

CLASS B

FREQUENCY (MHz)	Voltage Limit (dBuV)		Current Limit (dBuA)	
	Quasi-peak	Average	Quasi-peak	Average
0.15 - 0.5	84 - 74	74 - 64	40 - 30	30 - 20
0.5 - 30.0	74	64	30	20

Note: The lower limit shall apply at the transition frequency.

Maximum permissible level of Radiated Emission measured at 10 meter

FREQUENCY (MHz)	Class A (dBuV/m)	Class B (dBuV/m)
	Quasi-peak	Quasi-peak
30 - 230	40	30
230 - 1000	47	37

Note: The lower limit shall apply at the transition frequency.



7.2 TEST PROCEDURE OF LINE CONDUCTED EMISSION

Procedure of Preliminary Test

- The EUT was set up as per the test configuration to simulate typical usage per the user's manual. When the EUT is a tabletop system, a wooden table with a height of 0.8 meters is used and is placed on the ground plane as per EN 55022 (see Test Facility for the dimensions of the ground plane used). When the EUT is a floor-standing equipment, it is placed on the ground plane which has a 3-12 mm non-conductive covering to insulate the EUT from the ground plane.
- Support equipment, if needed, was placed as per EN 55022.
- All I/O cables were positioned to simulate typical actual usage as per EN 55022.
- The test system with EUT received AC power, 230V/50Hz, through a Line Impedance Stabilization Network (LISN), which supplied power source and was grounded to the ground plane.
- All support equipment received power from a second LISN.
- The EUT test program was started. Emissions were measured on each current carrying line of the EUT using an EMI Test Receiver connected to the LISN powering the EUT.
- The Receiver scanned from 150kHz to 30MHz for emissions in each of the test modes.
- During the above scans, the emissions were maximized by cable manipulation.
- The test mode(s) described in Item 3.2 were scanned during the preliminary test.
- After the preliminary scan, we found the test mode described in Item 3.2 producing the highest emission level.
- The EUT configuration and cable configuration of the above highest emission level were recorded for reference of the final test.

Procedure of Final Test

- EUT and support equipment were set up on the test bench as per the configuration with highest emission level in the preliminary test.
- A scan was taken on both power lines, Line 1 and Line 2, recording at least the six highest emissions. Emission frequency and amplitude were recorded into a computer in which correction factors were used to calculate the emission level and compare reading to the applicable limit. If EUT emission level was less -2dB to the Average limit in Q.P. mode, then the emission signal was re-checked using an Average detector.
- The test data of the worst-case condition(s) was recorded.

**Data Sample:**

Freq. MHz	Read Level dBuV	Factor dB	Level dBuV	Limit dBuV	Over Limit dB	Reading Type (P/Q/A)	Line (L1/L2)
x.xx	42.95	0.55	43.50	56	-12.50	Q	L1

- Freq. = Emission frequency in MHz
 Read Level = Uncorrected Analyzer/Receiver reading
 Factor = Insertion loss of LISN + Cable Loss
 Level = Read Level + Factor
 Limit = Limit stated in standard
 Over Limit = Reading in reference to limit
 P = Peak Reading
 Q = Quasi-peak Reading
 A = Average Reading
 L1 = Hot side
 L2 = Neutral side

Calculation Formula

Over Limit (dB) = Level (dBuV) – Limit (dBuV)

7.3 TEST PROCEDURE OF COMMON MODE CONDUCTED EMISSION FOR TELECOMMUNICATION PORT

- Selecting ISN for unscreened cable or a current probe for screened cable to take measurement.
- The port of the EUT was connected to the remote side support equipment through the ISN/Current Probe and communication in normal condition.
- Making a overall range scan by using the test receiver controlled by controller and record at least six highest emissions for showing in the test report.
- Emission frequency and amplitude were recorded into a computer in which correction factors were used to calculate the emission level and compare reading to the applicable limit.
- In case of measuring on the screened cable, the current limit shall be applied, otherwise the voltage limit should be applied.
- The following test mode(s) were scanned during the preliminary test:

Mode(s):

1.	10 Mbps
2.	100 Mbps

- After the preliminary scan, we found the following test mode(s) producing the highest emission level and test data of the worst case was recorded.

Mode: 2.

**Data Sample:**

Freq. MHz	Read Level dBuV	Factor dB	Level dBuV	Limit dBuV	Over Limit dB	Reading Type (P/Q/A)
x.xx	62.95	0.55	63.50	84	-20.50	Q

- Freq. = Emission frequency in MHz
Read Level = Uncorrected Analyzer/Receiver reading
Factor = Insertion loss of ISN + Cable Loss
Level = Read Level + Factor
Limit = Limit stated in standard
Over Limit = Reading in reference to limit
P = Peak Reading
Q = Quasi-peak Reading
A = Average Reading

Calculation Formula

$$\text{Over Limit (dB)} = \text{Level (dBuV)} - \text{Limit (dBuV)}$$

7.4 TEST PROCEDURE OF RADIATED EMISSION**Procedure of Preliminary Test**

- The equipment was set up as per the test configuration to simulate typical usage per the user's manual. When the EUT is a tabletop system, a wooden turntable with a height of 0.8 meters is used which is placed on the ground plane. When the EUT is a floor-standing equipment, it is placed on the ground plane which has a 3-12 mm non-conductive covering to insulate the EUT from the ground plane.
- Support equipment, if needed, was placed as per EN 55022.
- All I/O cables were positioned to simulate typical usage as per EN 55022.
- The EUT received AC power source, 230V/50Hz, from the outlet socket under the turntable. All support equipment received power from another socket under the turntable.
- Mains cables, telephone lines or other connections to auxiliary equipment located outside the test are shall drape to the floor, be fitted with ferrite clamps or ferrite tubes placed on the floor at the point where the cable reaches the floor and then routed to the place where they leave the turntable. No. extension cords shall be used to mains receptacle.
- The antenna was placed at 10 meter away from the EUT as stated in EN 55022. The antenna connected to the Spectrum Analyzer via a cable and at times a pre-amplifier would be used.
- The Analyzer / Receiver quickly scanned from 30MHz to 1000MHz. The EUT test program was started. Emissions were scanned and measured rotating the EUT to 360 degrees and positioning the antenna 1 to 4 meters above the ground plane, in both the vertical and the horizontal polarization, to maximize the emission reading level.



- The test mode(s) described in Item 3.2 were scanned during the preliminary test:
- After the preliminary scan, we found the test mode described in Item 3.2 producing the highest emission level.
- The EUT and cable configuration, antenna position, polarization and turntable position of the above highest emission level were recorded for the final test.

Procedure of Final Test

- EUT and support equipment were set up on the turntable as per the configuration with highest emission level in the preliminary test.
- The Analyzer / Receiver scanned from 30MHz to 1000MHz. Emissions were scanned and measured rotating the EUT to 360 degrees, varying cable placement and positioning the antenna 1 to 4 meters above the ground plane, in both the vertical and the horizontal polarization, to maximize the emission reading level.
- Recorded at least the six highest emissions. Emission frequency, amplitude, antenna position, polarization and turntable position were recorded into a computer in which correction factors were used to calculate the emission level and compare reading to the applicable limit and only Q.P. reading is presented.

Data Sample:

Freq. MHz	Read Level dBuV	Factor dB/m	Level dBuV/m	Limit dBuV/m	Over Limit dB	Reading Type (P/Q/A)	Pol. (H/V)
x.xx	14.0	12.2	26.2	30	-3.8	Q	H

Freq. = Emission frequency in MHz
 Read Level = Uncorrected Analyzer/Receiver reading
 Factor = Antenna Factor + Cable Loss + Attenuator (3/6/10dB) – Amplifier Gain
 Level = Read Level + Factor
 Limit = Limit stated in standard
 Over Limit = Reading in reference to limit
 P = Peak Reading
 Q = Quasi-peak Reading
 A = Average Reading
 H = Antenna Polarization: Horizontal
 V = Antenna Polarization: Vertical

Calculation Formula

Over Limit (dB) = Level (dBuV/m) – Limit (dBuV/m)



7.5 TEST RESULTS

Line Conducted Emission

Model: PFM-532I**Test Mode:** Mode 1**Temperature:** 23 °C**Humidity:** 55 % RH**Test Results:** Passed**Tested by:** ALEX PAN

(The chart below shows the highest readings taken from the final data)

Six Highest Conducted Emission Readings							
Frequency Range Investigated				150 kHz to 30 MHz			
Freq (MHz)	Read Level (dBuV)	Factor (dB)	Level (dBuV)	Limit Line (dBuV)	Over Limit (dB)	Reading Type (P/Q/A)	Line (L1/L2)
0.269	39.95	0.18	40.13	61.16	-21.03	P	L1
15.552	40.87	1.25	42.12	60.00	-17.88	P	L1
20.814	38.54	1.65	40.19	60.00	-19.81	P	L1
0.419	35.49	0.19	35.68	57.46	-21.79	P	L2
7.368	37.73	0.73	38.46	60.00	-21.54	P	L2
15.552	40.77	1.44	42.21	60.00	-17.79	P	L2

NOTE: The emission level was or more than 2dB below the Average limit, so no re-check anymore.

Common Mode Conducted Emission

Test Mode: Mode 2

Six Highest Conducted Emission Readings						
Frequency Range Investigated				150 kHz to 30 MHz		
Freq (MHz)	Read Level (dBuV)	Factor (dB)	Level (dBuV)	Limit Line (dBuV)	Over Limit (dB)	Reading Type (P/Q/A)
5.898	47.81	10.25	58.06	74.00	-15.94	P
9.451	47.24	10.32	57.56	84.00	-26.44	P
12.188	56.90	10.34	67.24	84.00	-16.76	P
13.408	57.20	10.34	67.54	84.00	-16.46	P
15.552	56.60	10.35	66.96	84.00	-17.04	P
16.750	53.74	10.36	64.11	84.00	-19.89	P

NOTE: The relaxation of 10dB over the frequency range of 6MHz to 30 MHz is according to clause 5.2 table 4 note 3 of EN55022 until b reviewed no later than three years after the date of withdrawal.

**Radiated Emission****Model:** PFM-532I**Test Mode:** Mode 1**Temperature:** 25°C**Humidity:** 60% RH**Test Results:** Passed**Tested by:** ELVIS ZENG

(The chart below shows the highest readings taken from the final data.)

Six Highest Radiated Emission Readings							
Frequency Range Investigated				30 MHz to 1000 MHz at 10m			
Freq (MHz)	Read Level (dBuV)	Factor (dB)	Level (dBuV)	Limit Line (dBuV)	Over Limit (dB)	Reading Type (P/Q/A)	Pol. (H/V)
66.300	41.20	-15.44	25.76	30.00	-4.24	Q	V
125.032	34.70	-9.25	25.45	30.00	-4.55	Q	V
157.476	36.60	-10.91	25.69	30.00	-4.31	Q	V
125.030	35.10	-9.25	25.85	30.00	-4.15	Q	H
133.340	34.90	-9.56	25.34	30.00	-4.66	Q	H
165.090	36.70	-11.05	25.65	30.00	-4.35	Q	H

NOTE: None.



8 POWER HARMONICS TEST

Port : AC Power Port
Basic Standard : EN 61000-3-2 (2000)
Limits : CLASS A ; CLASS D
Tested by : ALEX PAN
Temperature : 25°C
Humidity : 58%

Limit:

Limits for Class A equipment	
Harmonics Order n	Max. permissible harmonics current A
Odd harmonics	
3	2.30
5	1.14
7	0.77
9	0.40
11	0.33
13	0.21
15<=n<=39	0.15x15/n
Even harmonics	
2	1.08
4	0.43
6	0.30
8<=n<=40	0.23x8/n

Limits for Class D equipment		
Harmonics Order n	Max. permissible harmonics current per watt mA/W	Max. permissible harmonics current A
Odd Harmonics only		
3	3.4	2.30
5	1.9	1.14
7	1.0	0.77
9	0.5	0.40
11	0.35	0.33
13	0.30	0.21
15<=n<=39	3.85/n	0.15x15/n

Block Diagram of Test Setup:

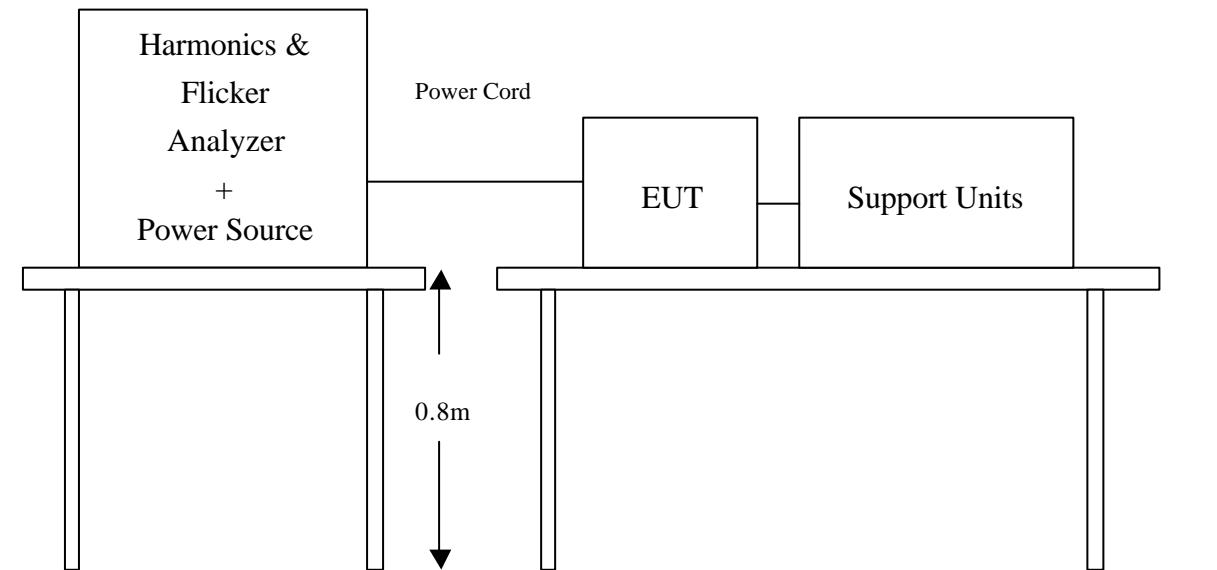

Test Procedure:

- a. The EUT was placed on the top of a wooden table 0.8 meters above the ground and operated to produce the maximum harmonic components under normal operating conditions for each successive harmonic component in turn.
- b. The correspondent test program of test instrument to measure the current harmonics emanated from EUT is chosen. The measure time shall be not less than the time necessary for the EUT to be exercised.

Test Result : (See Appendix II for details)

<input checked="" type="checkbox"/> PASS <input type="checkbox"/> FAIL
<p>Note: No function degraded during the tests.</p>

9 POWER VOLTAGE FLUCTUATION / FLICKER TEST

Port : AC Power Port
Basic Standard : EN 61000-3-3 (1995 + A1: 2001)
Limits : § of EN 61000-3-3
Tested by : ALEX PAN
Temperature : 25°C
Humidity : 58%

Limit:

TEST ITEM	LIMIT	REMARK
P_{st}	1.0	P_{st} means short-term flicker indicator.
P_{lt}	0.65	P_{lt} means long-term flicker indicator.
T_{dt} (ms)	500	T_{dt} means maximum time that dt exceeds 3.3 %.
d_{max} (%)	4%	d_{max} means maximum relative voltage change.
dc (%)	3.3%	dc means relative steady-state voltage change

Block Diagram of Test Setup:

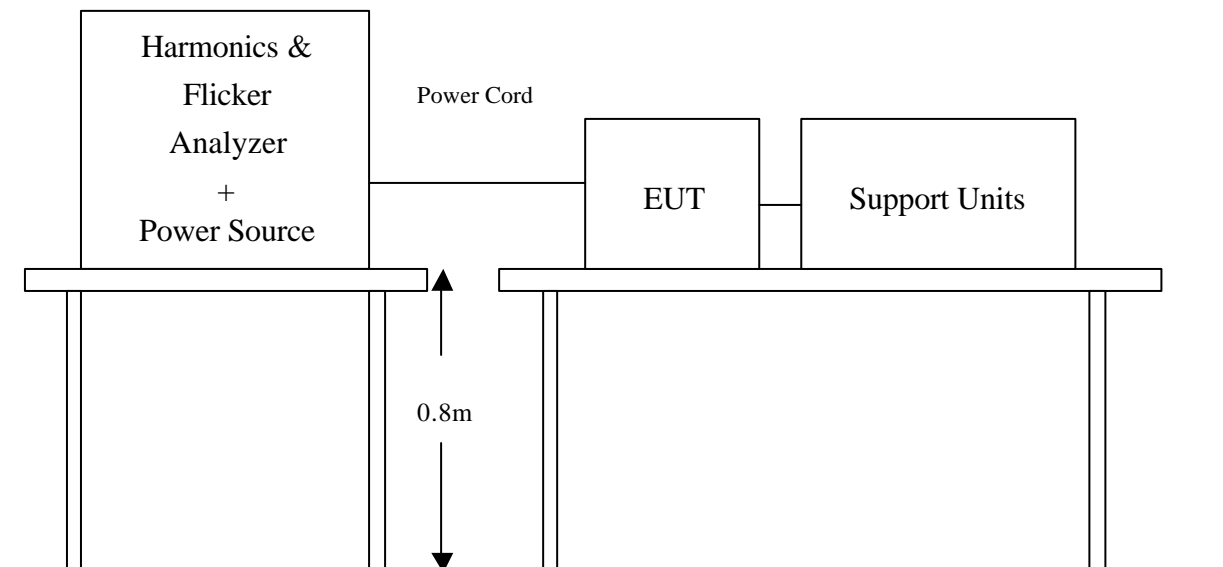



Test Procedure:

- a. The EUT was placed on the top of a wooden table 0.8 meters above the ground and operated to produce the most unfavorable sequence of voltage changes under normal operating conditions.
- b. During the flick measurement, the measure time shall include that part of whole operation cycle in which the EUT produce the most unfavorable sequence of voltage changes. The observation period for short-term flicker indicator is 10 minutes and the observation period for long-term flicker indicator is 2 hours.

Test Result: (See Appendix II for details)

TEST PARAMETER	MEASUREMENT VALUE	LIMIT	RESULT
P_{st}	0.038	1.0	Pass
P_{1t}	0.016	0.65	Pass
T_{dt} (ms)	0	500	Pass
d_{max} (%)	-0.07	4%	Pass
dc (%)	0	3.3%	Pass

Note: None.

10 ELECTROSTATIC DISCHARGE (ESD) IMMUNITY TEST

Port	: Enclosure
Basic Standard	: IEC/EN 61000-4-2
Test Level	: ± 8 kV (Air Discharge) ± 4 kV (Contact Discharge) ± 4 kV (Indirect Discharge)
Performance Criterion:	B (Standard Required)
Tested by	: JASON CHIA
Temperature	: 25°C
Humidity	: 58%
Pressure	: 1018mbar

Block Diagram of Test Setup:

(The 470 k ohm resistors are installed per standard requirement.)

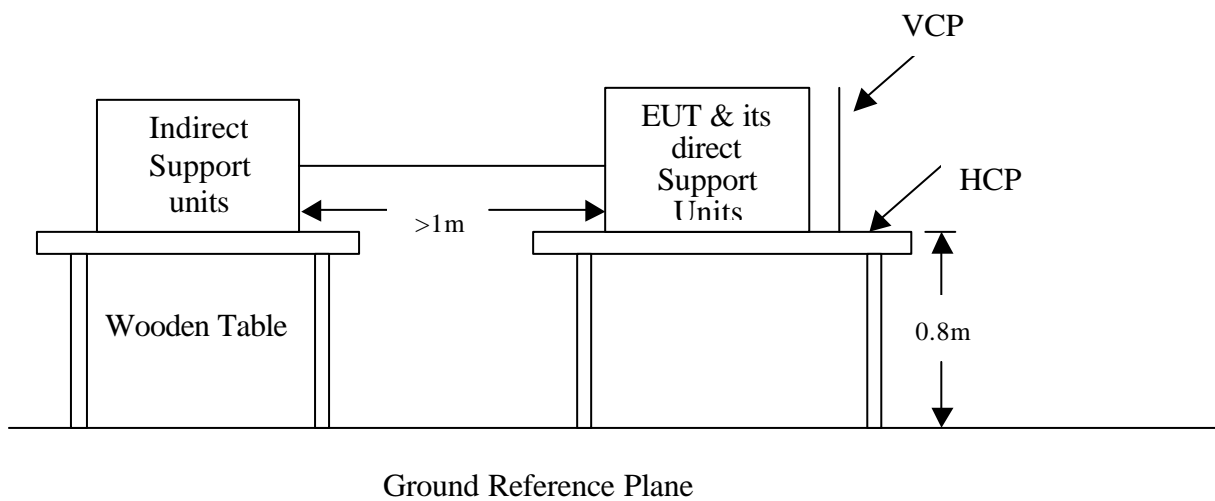

**Test Procedure:**

1. The EUT was located 0.1 m minimum from all sides of the HCP.
2. The indirect support units were located 1 m minimum away from the EUT, but direct support unit was/were located at same location as EUT on the HCP and keep at a distance of 10 cm with EUT.
3. As per the requirement of EN 55024; applying direct contact discharge at the sides other than front of EUT at minimum 50 discharges (25 positive and 25 negative) if applicable, can't be applied direct contact discharge side of EUT then the indirect discharge shall be applied. One of the test points shall be subjected to at least 50 indirect discharge (contact) to the front edge of horizontal coupling plane.
4. Other parts of EUT where it is not possible to perform contact discharge then selecting appropriate points of EUT for air discharge, a minimum of 10 single air discharges shall be applied.
5. The application of ESD to the contact of open connectors is not required.
6. The EUT direct connection units also need to be applied ESD at the port of EUT cable connected.
7. Putting a mark on EUT to show tested points. The following test condition was followed during the tests.

Note: As per IEC/EN 61000-4-2, two 470k bleed resistors cable is connected between the EUT and HCP during the test applicable for power ungrounded or battery operating unit only.

The electrostatic discharges were applied as follows:

Amount of discharge	Voltage	Coupling	Result (Pass/Fail)
Mini 10 /Point	± 8 kV	Air Discharge	Pass
Mini 25 /Point	± 4 kV	Contact Discharge	Pass
Mini 25 /Point	± 4 kV	Indirect Discharge HCP (Front)	Pass
Mini 25 /Point	± 4 kV	Indirect Discharge VCP (Right)	Pass
Mini 25 /Point	± 4 kV	Indirect Discharge VCP (Left)	Pass
Mini 25 /Point	± 4 kV	Indirect Discharge VCP (Back)	Pass

***For the tested points to EUT, please refer to attached page.
(Blue arrow mark for Contact Discharge and red arrow mark for Air Discharge)**

The Tested Points of EUT

Photo 1 of 5



Photo 2 of 5



Photo 3 of 5



Photo 4 of 5





Photo 5 of 5





Performance & Result:

- Criterion A:** The apparatus continues to operate as intended. No degradation of performance or loss of function is allowed below a performance level specified by the manufacturer, when the apparatus is used as intended. In some cases the performance level may be replaced by a permissible loss of performance.
- Criterion B:** The apparatus continues to operate as intended after the test. No degradation of performance or loss of function is allowed below a performance level specified by the manufacturer, when the apparatus is used as intended. In some cases the performance level may be replaced by a permissible loss of performance. During the test, degradation of performance is however allowed.
- Criterion C:** Temporary loss of function is allowed, provided the functions self recoverable or can be restored by the operation of controls.

PASS **FAIL**

Observation: No function degraded during the tests.

11 RADIATED ELECTROMAGNETIC FIELD IMMUNITY TEST

Port	: Enclosure
Basic Standard	: IEC/EN 61000-4-3
Requirements	: 3 V/m / with 80% AM. 1kHz Modulation.
Performance Criterion:	A (Standard Required)
Tested by	: JASON CHIA
Temperature	: 25°C
Humidity	: 58%
Pressure	: 1018mbar

Block Diagram of Test Setup:

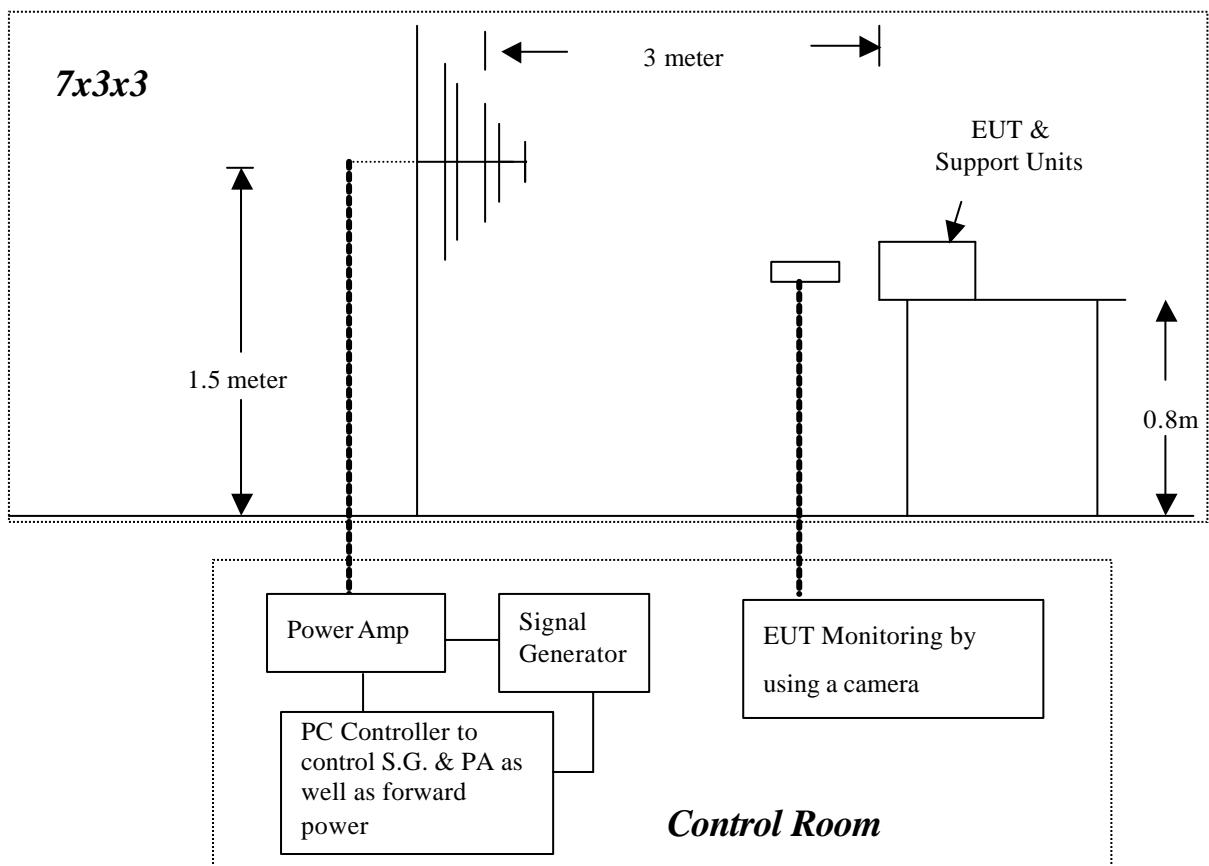

**Test Procedure:**

1. The EUT and support units were located at the edge of supporting table keep 3 meter away from transmitting antenna, it just the calibrated square area of field uniformity.
2. Adjusting the cables to be exposed to the electromagnetic field as possible.
3. Performing a Radiated Emission Scan in range of 80 to 1000 MHz prior to do RS test and records the more higher emission frequencies for the reference of RS test, due to antenna effectiveness.
4. Adjusting the monitoring camera to monitor the “H” message as clear as possible.
5. Setting the testing parameters of RS test software per IEC 61000-4-3.
6. Referring to the tested data of step 3 to performing the RS test from 80 to 1000 MHz.
7. Recording the test result in following table.
8. Changing the EUT to the other side and repeat step 3 to 6, until 4 sides of EUT were verified.

IEC 61000-4-3 Final test conditions:

Test level : 3V/m
 Steps : 1 % of fundamental
 Dwell Time : 3 sec

Range (MHz)	Field	Modulation	Polarity	Position (°)	Result (Pass/Fail)
80-1000	3V/m	Yes	H	Front	Pass
80-1000	3V/m	Yes	V	Front	Pass
80-1000	3V/m	Yes	H	Right	Pass
80-1000	3V/m	Yes	V	Right	Pass
80-1000	3V/m	Yes	H	Back	Pass
80-1000	3V/m	Yes	V	Back	Pass
80-1000	3V/m	Yes	H	Left	Pass
80-1000	3V/m	Yes	V	Left	Pass



Performance & Result:

- Criterion A:** The apparatus continues to operate as intended. No degradation of performance or loss of function is allowed below a performance level specified by the manufacturer, when the apparatus is used as intended. In some cases the performance level may be replaced by a permissible loss of performance.

- Criterion B:** The apparatus continues to operate as intended after the test. No degradation of performance or loss of function is allowed below a performance level specified by the manufacturer, when the apparatus is used as intended. In some cases the performance level may be replaced by a permissible loss of performance. During the test, degradation of performance is however allowed.

- Criterion C:** Temporary loss of function is allowed, provided the functions self recoverable or can be restored by the operation of controls.

<input checked="" type="checkbox"/> PASS <input type="checkbox"/> FAIL
Observation: No function degraded during the tests.

12 FAST TRANSIENTS/BURST IMMUNITY TEST

Port	: AC Power Port and RJ45 Port
Basic Standard	: IEC/EN 61000-4-4
Requirements	: ± 1 kV for AC Power Port ± 0.5 kV for RJ45 Port
Performance Criteria	: B (Standard Required)
Tested by	: JASON CHIA
Temperature	: 25°C
Humidity	: 58%
Pressure	: 1018mbar

Block Diagram of Test Setup:

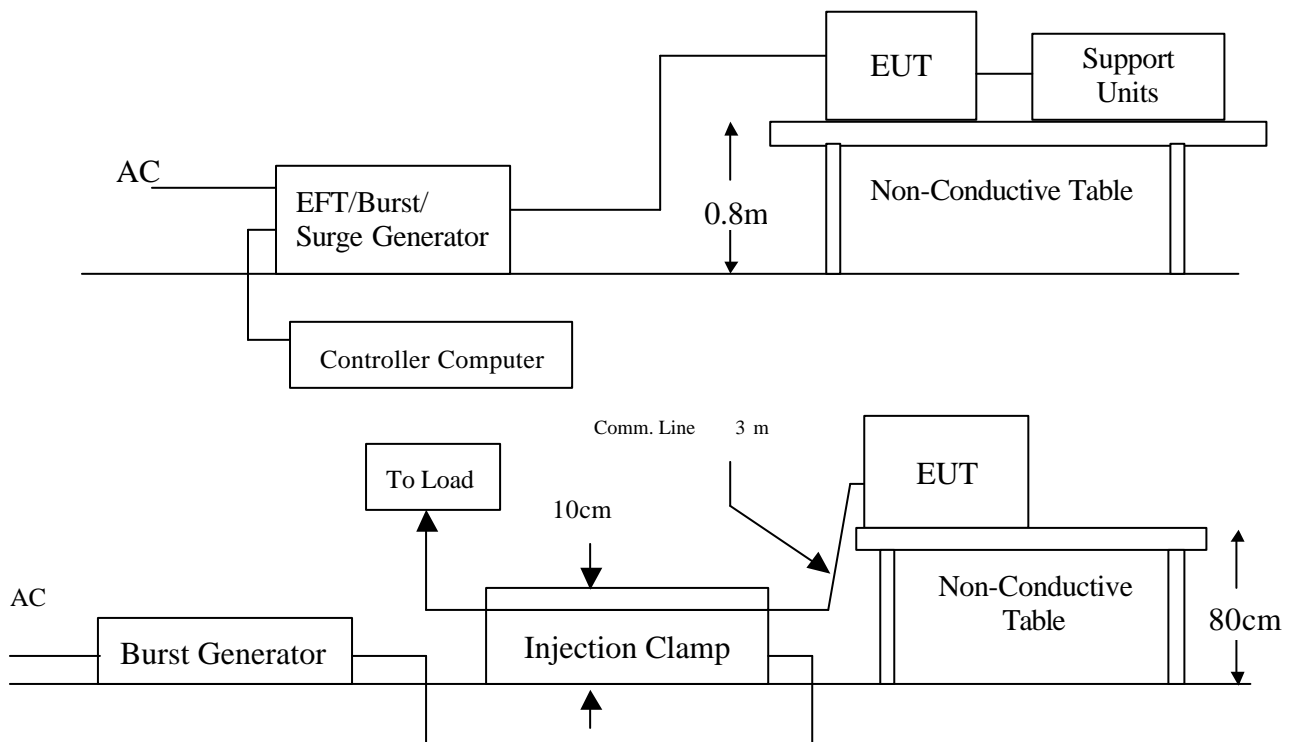

Test Procedure:

1. The EUT and support units were located on a wooden table 0.8 m away from ground reference plane.
2. A 1.0 meter long power cord was attached to EUT during the test.
3. The length of communication cable between communication port and clamp was keeping within 1 meter.
4. Injected test voltage to the EUT ports from minimum to standard request or client request.
5. Recorded the test result as shown in following table.

**Test conditions:**

Impulse Frequency : 5kHz
 Tr/Th : 5/50ns
 Burst Duration : 15ms
 Burst Period : 300ms

Inject Line	Voltage kV	Inject Method	Result (Pass/Fail)
L	± 1	Direct	Pass
N	± 1	Direct	Pass
PE	± 1	Direct	Pass
L + N	± 1	Direct	Pass
L + PE	± 1	Direct	Pass
N + PE	± 1	Direct	Pass
L + N + PE	± 1	Direct	Pass
RJ45	±0.5	Clamp	Pass

Performance & Result:

- Criterion A:** The apparatus continues to operate as intended. No degradation of performance or loss of function is allowed below a performance level specified by the manufacturer, when the apparatus is used as intended. In some cases the performance level may be replaced by a permissible loss of performance.
- Criterion B:** The apparatus continues to operate as intended after the test. No degradation of performance or loss of function is allowed below a performance level specified by the manufacturer, when the apparatus is used as intended. In some cases the performance level may be replaced by a permissible loss of performance. During the test, degradation of performance is however allowed.
- Criterion C:** Temporary loss of function is allowed, provided the functions self recoverable or can be restored by the operation of controls.

PASS **FAIL**

Observation: No function degraded during the tests.

13 SURGE IMMUNITY TEST

Port	: AC Power Port
Basic Standard	: IEC/EN 61000-4-5
Requirements	: ± 1 kV (Line to Line) for AC Power Port ± 2 kV (Line to Ground) for AC Power Port
Performance Criteria	: B (Standard Required)
Tested by	: JASON CHIA
Temperature	: 25°C
Humidity	: 58%
Pressure	: 1018mbar

Block Diagram of Test Setup:

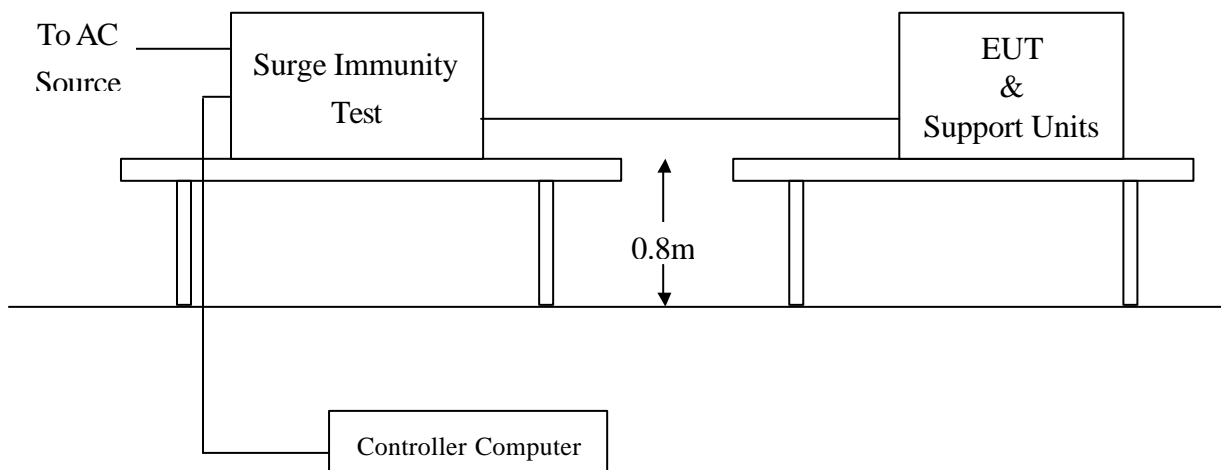

Test Procedure:

1. The EUT and support units were located on a wooden table 0.8 m away from ground floor.
2. Injected test voltage to the EUT ports from minimum to standard request or client request.
3. Recorded the test result as shown in following table.

**Test conditions:**

Voltage Waveform : 1.2/50 *us*
 Current Waveform : 8/20 *us*
 Polarity : Positive/Negative
 Phase angle : 0°, 90°, 270°
 Number of Test : 5

Coupling Line	Voltage (kV)	Polarity	Coupling Method	Result (Pass/Fail)
L1-L2	1	Positive	Capacitive	Pass
L1-PE	2	Positive	Capacitive	Pass
L2-PE	2	Positive	Capacitive	Pass
L1-L2	1	Negative	Capacitive	Pass
L1-PE	2	Negative	Capacitive	Pass
L2-PE	2	Negative	Capacitive	Pass

Performance & Result:

- Criterion A:** The apparatus continues to operate as intended. No degradation of performance or loss of function is allowed below a performance level specified by the manufacturer, when the apparatus is used as intended. In some cases the performance level may be replaced by a permissible loss of performance.
- Criterion B:** The apparatus continues to operate as intended after the test. No degradation of performance or loss of function is allowed below a performance level specified by the manufacturer, when the apparatus is used as intended. In some cases the performance level may be replaced by a permissible loss of performance. During the test, degradation of performance is however allowed.
- Criterion C:** Temporary loss of function is allowed, provided the functions self recoverable or can be restored by the operation of controls.

PASS **FAIL**

Observation: Where normal functioning of LAN can't be achieved because of the impact of CDN on the EUT, no test be required.

14 CONDUCTED DISTURBANCE/INDUCED RADIO-FREQUENCY FIELD IMMUNITY TEST

Port	: AC Power Port and RJ45 Port
Basic Standard	: IEC/EN 61000-4-6
Requirements	: 3 V, with 80% AM. 1kHz Modulation.
Injection Method	: CDN-M3 for AC Power Port CDN-T4 for RJ45 Port
Performance Criterion	: A (Standard Required)
Tested by	: JASON CHIA
Temperature	: 25°C
Humidity	: 58%
Pressure	: 1018mbar

Block Diagram of Test Setup:

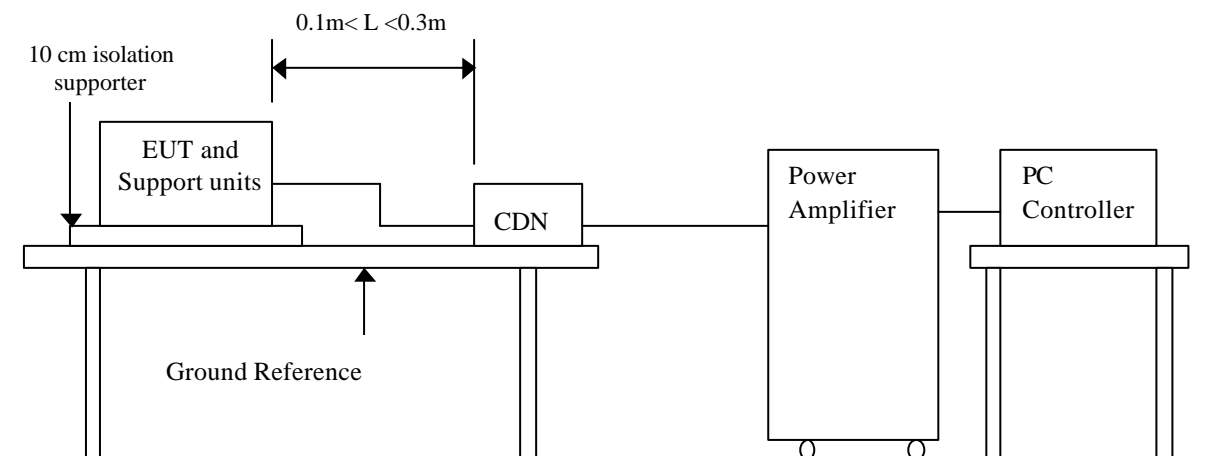

Test Procedure:

1. The EUT and support units were located at a ground reference plane with the interposition of a 0.1 m thickness insulating support and the CDN was located on GRP directly.
2. Set the testing parameters of CS test software as per IEC/EN 61000-4-6.
3. Recorded the test result in following table.



Test conditions:

Frequency Range : 0.15MHz-80MHz

Frequency Step : 1% of fundamental

Dwell Time : 3 sec

Range (MHz)	Field	Modulation	Result (Pass/Fail)
0.15-80	3V	Yes	Pass

Performance & Result:

Criterion A: The apparatus continues to operate as intended. No degradation of performance or loss of function is allowed below a performance level specified by the manufacturer, when the apparatus is used as intended. In some cases the performance level may be replaced by a permissible loss of performance.

Criterion B: The apparatus continues to operate as intended after the test. No degradation of performance or loss of function is allowed below a performance level specified by the manufacturer, when the apparatus is used as intended. In some cases the performance level may be replaced by a permissible loss of performance. During the test, degradation of performance is however allowed.

Criterion C: Temporary loss of function is allowed, provided the functions self recoverable or can be restored by the operation of controls.

<input checked="" type="checkbox"/> PASS <input type="checkbox"/> FAIL
Observation: No function degraded during the tests.

15 POWER FREQUENCY MAGNETIC FIELD IMMUNITY TEST

Port	: Enclosure
Basic Standard	: IEC/EN 61000-4-8
Requirements	: 1 A/m
Performance Criterion	: A (Standard Required)
Tested by	: N/A
Temperature	: N/A
Humidity	: N/A
Pressure	: N/A

Block Diagram of Test Setup:

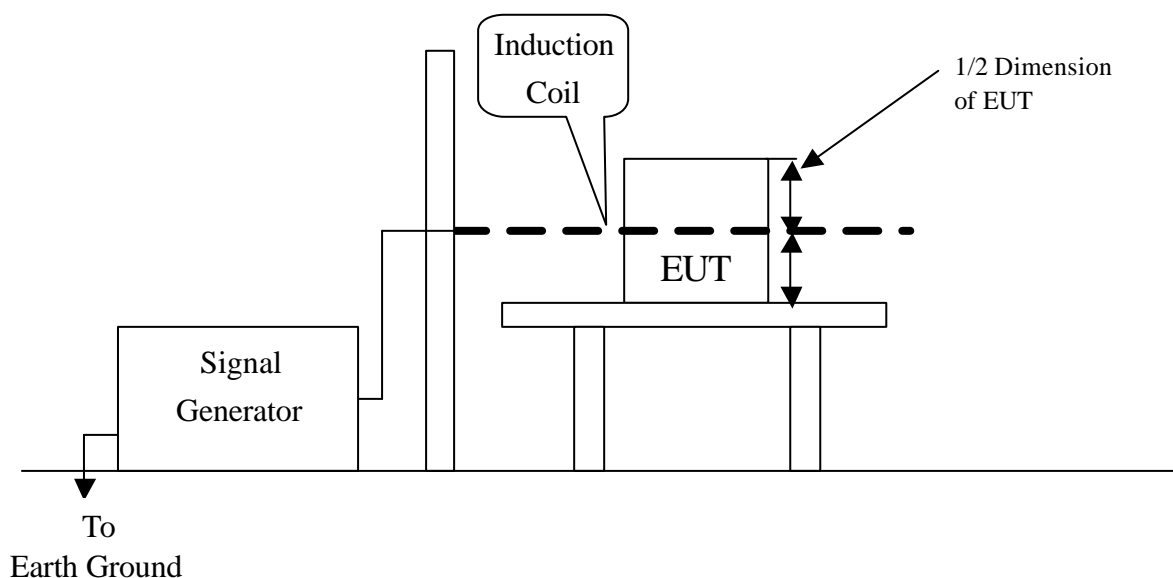

Test Procedure:

1. The EUT and support units were located on Ground Reference Plane with the interposition of a 0.1 m thickness insulation support.
2. Put the induction coil on horizontal direction. (X direction)
3. Recorded the test result as shown in following table.
4. Rotated the induction coil by 90° (Y direction) then repeat step 3.
5. Rotated the induction coil by 90° (Z direction) then repeat step 3.



Test conditions:

Field Strength: 1A/m
Power Freq.: 50Hz
Orientation: X, Y, Z

Orientation	Field	Result (Pass/Fail)	Remark

Performance & Result:

- Criterion A:** The apparatus continues to operate as intended. No degradation of performance or loss of function is allowed below a performance level specified by the manufacturer, when the apparatus is used as intended. In some cases the performance level may be replaced by a permissible loss of performance.
- Criterion B:** The apparatus continues to operate as intended after the test. No degradation of performance or loss of function is allowed below a performance level specified by the manufacturer, when the apparatus is used as intended. In some cases the performance level may be replaced by a permissible loss of performance. During the test, degradation of performance is however allowed.
- Criterion C:** Temporary loss of function is allowed, provided the functions self recoverable or can be restored by the operation of controls.

<input type="checkbox"/> PASS <input type="checkbox"/> FAIL
Observation: The EUT is not containing any component that is susceptible to a 50 Hz or 60 Hz magnetic fail. Therefore, this requirement is not applicable to the EUT.

16 VOLTAGE DIPS / SHORT INTERRUPTIONS

Port : AC Power Port
Basic Standard : IEC/EN 61000-4-11
Requirement : PHASE ANGLE 0, 45, 90, 135, 180, 225, 270, 315 degrees
Test Interval : Min. 10 sec.
Tested by : JASON CHIA
Temperature : 25°C
Humidity : 58%
Pressure : 1018mbar

Voltage Dips	Test Level % U_T	Reduction (%)	Duration (periods)	Performance Criterion
	<5	>95	0.5	B
	70	30	25	C

Voltage Interruptions	Test Level % U_T	Reduction (%)	Duration (periods)	Performance Criterion
	<5	>95	250	C

Block Diagram of Test Setup:

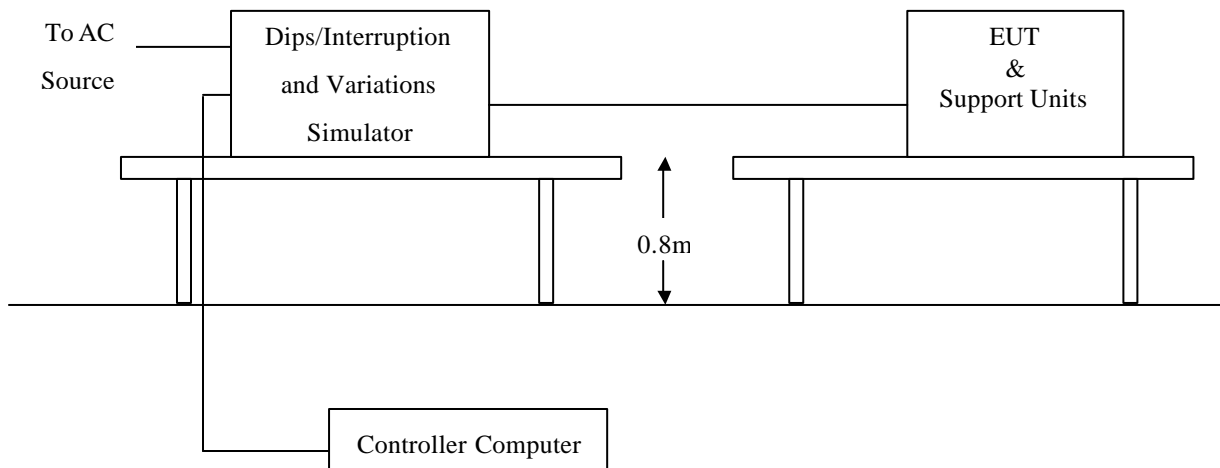

Test Procedure:

1. The EUT and support units were located on a wooden table, 0.8 m away from ground floor.
2. Set the parameter of tests and then Performed the test software of test simulator.
3. Changed Condition to occur at 0 degree crossover point of the voltage waveform.
4. Recorded the test result in test record form.

**Test conditions:**

The duration with a sequence of three dips/interruptions with interval of 10 sec. minimum (Between each test event)

Voltage Dips:

Test Level % U _T	Reduction (%)	Duration (periods)	Observation	Meet Performance Criterion
0	100	0.5	Normal	A
70	30	25	Normal	A

Voltage Interruptions:

Test Level % U _T	Reduction (%)	Duration (periods)	Observation	Meet Performance Criterion
0	100	250	EUT shut down, but EUT can be auto recovered after it restart.	C

Note: "Normal" means no any functions degrade during and after the test.

Performance & Result:

Criterion A: The apparatus continues to operate as intended. No degradation of performance or loss of function is allowed below a performance level specified by the manufacturer, when the apparatus is used as intended. In some cases the performance level may be replaced by a permissible loss of performance.

Criterion B: The apparatus continues to operate as intended after the test. No degradation of performance or loss of function is allowed below a performance level specified by the manufacturer, when the apparatus is used as intended. In some cases the performance level may be replaced by a permissible loss of performance. During the test, degradation of performance is however allowed.

Criterion C: Temporary loss of function is allowed, provided the functions self recoverable or can be restored by the operation of controls.

PASS **FAIL**

Observation: No function degraded during the tests.

APPENDIX I - PHOTOGRAPHS OF TEST SETUP

LINE CONDUCTED EMISSION TEST (EN 55022)



COMMON MODE CONDUCTED EMISSION TEST



RADIATED EMISSION TEST



POWER HARMONIC & VOLTAGE FLUCTUATION / FLICKER TEST



ELECTROSTATIC DISCHARGE TEST

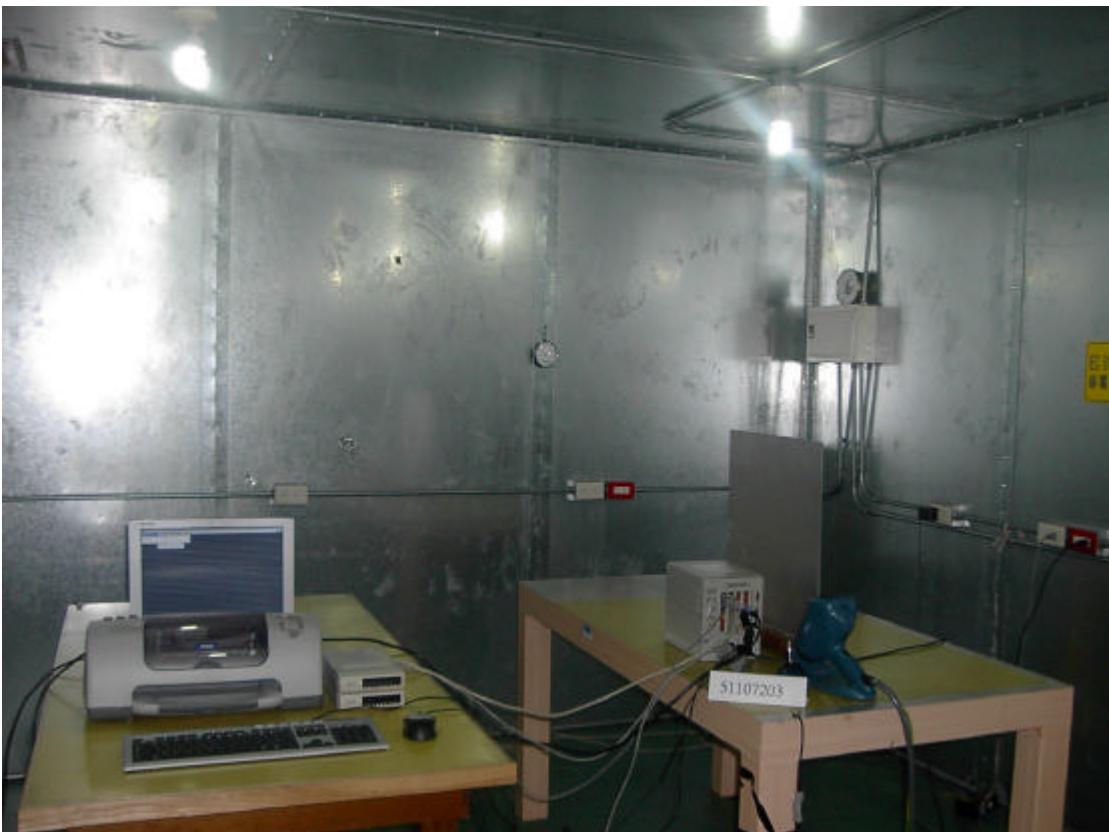

RADIATED ELECTROMAGNETIC FIELD TEST



FAST TRANSIENTS/BURST TEST



(IEC 61000-4-4 FOR I/O)



SURGE IMMUNITY TEST



CONDUCTED DISTURBANCE, INDUCED BY RADIO-FREQUENCY FIELDS TEST



(IEC 61000-4-6 FOR I/O)





VOLTAGE DIPS / INTERRUPTION TEST





APPENDIX II – TEST RESULT OF EN 61000-3-2/-3

Test Result: Pass

Source qualification: Normal

Current & voltage waveforms

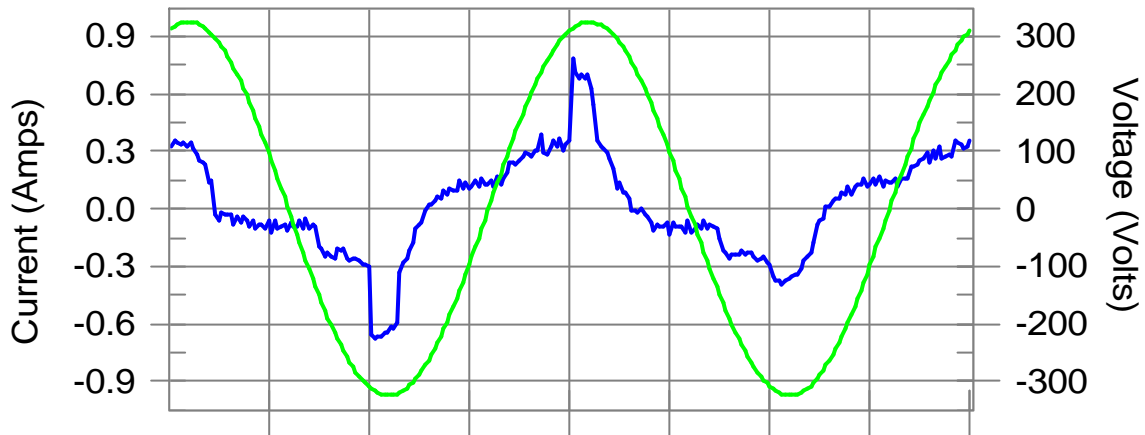

Harmonics and Class D limit line

European Limits

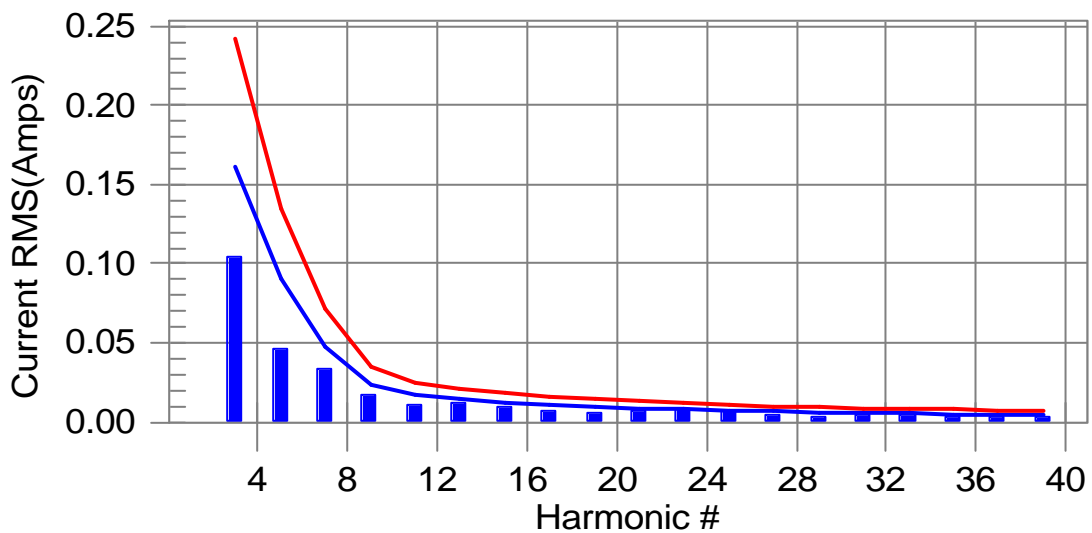

Test result: Pass

Worst harmonic was #23 with 67.00 % of the limit.



Test Result: Pass

Source qualification: Normal

THC(A): 0.127

THD(pk%): 56.436

POHC(A): N/A

POHC Limit(A): N/A

Highest parameter values during test:

V_RMS (Volts): 229.91

I_Peak (Amps): 0.788

I_RMS (Amps): 0.289

I_Fund (Amps): 0.266

Crest Factor: 2.993

Power (Watts): 50

Power Factor: 0.783

Harm#	Harms(avg)	100%Limit	%of Limit	Harms(max)	150%Limit	%of Limit	Status
2	0.000						
3	0.099	0.161	61.5	0.105	0.242	43.30	Pass
4	0.000						
5	0.038	0.090	41.6	0.046	0.135	34.30	Pass
6	0.000						
7	0.026	0.047	54.4	0.034	0.071	47.40	Pass
8	0.000						
9	0.012	0.024	51.5	0.017	0.036	47.66	Pass
10	0.000						
11	0.007	0.017	44.6	0.011	0.025	43.04	Pass
12	0.000						
13	0.008	0.014	58.8	0.012	0.021	57.13	Pass
14	0.000						
15	0.007	0.012	53.0	0.010	0.018	52.74	Pass
16	0.000						
17	0.005	0.011	46.6	0.007	0.016	42.92	Pass
18	0.000						
19	0.004	0.010	45.8	0.006	0.014	40.54	Pass
20	0.000						
21	0.005	0.009	54.7	0.007	0.013	51.87	Pass
22	0.000						
23	0.006	0.008	76.3	0.008	0.012	67.00	Pass
24	0.000						
25	0.005	0.007	66.1	0.007	0.011	61.70	Pass
26	0.000						
27	0.003	0.007	39.7	0.004	0.010	40.25	Pass
28	0.000						
29	0.002	0.006	38.5	0.003	0.009	36.82	Pass
30	0.000						
31	0.004	0.006	63.7	0.005	0.009	56.64	Pass
32	0.000						
33	0.003	0.006	56.6	0.004	0.008	52.82	Pass
34	0.000						
35	0.002	0.005	45.3	0.004	0.008	47.74	Pass
36	0.000						
37	0.002	0.005	39.8	0.003	0.007	38.08	Pass
38	0.000						
39	0.002	0.005	51.7	0.003	0.007	46.89	Pass
40	0.000						



Test Result: Pass

Source qualification: Normal

Highest parameter values during test:

Voltage (Vrms): 229.91

I_Peak (Amps): 0.788

I_RMS (Amps): 0.289

I_Fund (Amps): 0.266

Crest Factor: 2.993

Power (Watts): 50

Power Factor: 0.783

Harm#	Harmonics V-rms	Limit V-rms	% of Limit	Status
2	0.151	0.460	32.74	OK
3	0.395	2.069	19.08	OK
4	0.052	0.460	11.23	OK
5	0.026	0.919	2.84	OK
6	0.200	0.460	43.53	OK
7	0.039	0.690	5.61	OK
8	0.039	0.460	8.59	OK
9	0.047	0.460	10.19	OK
10	0.028	0.460	6.10	OK
11	0.072	0.230	31.21	OK
12	0.024	0.230	10.47	OK
13	0.031	0.230	13.46	OK
14	0.017	0.230	7.59	OK
15	0.013	0.230	5.51	OK
16	0.017	0.230	7.61	OK
17	0.015	0.230	6.42	OK
18	0.039	0.230	16.81	OK
19	0.012	0.230	5.20	OK
20	0.019	0.230	8.10	OK
21	0.019	0.230	8.38	OK
22	0.016	0.230	6.82	OK
23	0.027	0.230	11.70	OK
24	0.016	0.230	6.78	OK
25	0.045	0.230	19.39	OK
26	0.018	0.230	7.67	OK
27	0.011	0.230	4.75	OK
28	0.014	0.230	6.06	OK
29	0.013	0.230	5.65	OK
30	0.035	0.230	15.22	OK
31	0.011	0.230	4.68	OK
32	0.012	0.230	5.23	OK
33	0.009	0.230	3.92	OK
34	0.007	0.230	3.22	OK
35	0.020	0.230	8.75	OK
36	0.008	0.230	3.48	OK
37	0.018	0.230	8.00	OK
38	0.009	0.230	3.89	OK
39	0.010	0.230	4.37	OK
40	0.012	0.230	5.04	OK



Test Result: Pass

Status: Test Completed

Pst_i and limit line

European Limits

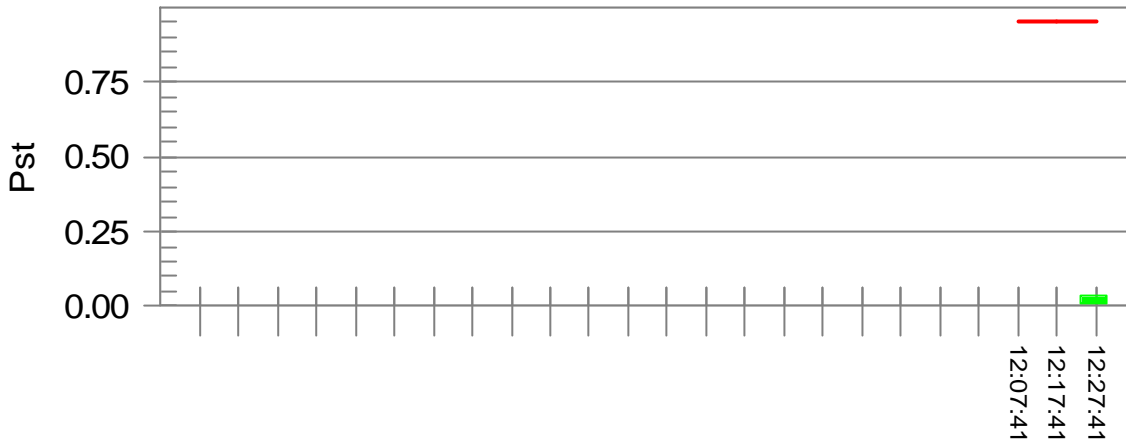

Time is too short for Plt plot

Parameter values recorded during the test:

Vrms at the end of test (Volt):	229.96			
Highest dt (%):	-0.14	Test limit (%):	3.14	Pass
Time(mS) > dt:	0.0	Test limit (mS):	500.0	Pass
Highest dc (%):	0.00	Test limit (%):	3.14	Pass
Highest dmax (%):	-0.07	Test limit (%):	3.80	Pass
Highest Pst (10 min. period):	0.038	Test limit:	0.950	Pass
Highest Plt (2 hr. period):	0.016	Test limit:	0.617	Pass