



SPORTON LAB.

Certificate No: C882605

CERTIFICATE



Equipment Under Test : IPC with CPU Board & LCD Panel

Model No. : IPC-610XX, PCM-3540T, PCM-3540R, PCM-3521

Applicant : **ADVANTECH CO., LTD.**

Fl. 4, No. 108-3, Ming-Chuan Road, Shing-Tien City,
Taipei, Taiwan, R.O.C.

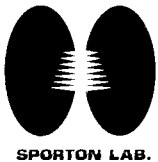

CERTIFY THAT:

THE MEASUREMENTS SHOWN IN THIS TEST REPORT WERE MADE IN ACCORDANCE WITH THE PROCEDURES GIVEN IN **EUROPEAN COUNCIL DIRECTIVE 89/336/EEC**. THE EQUIPMENT WAS **PASSED** THE TEST PERFORMED ACCORDING TO **EUROPEAN STANDARD EN 55022/A1 Class A, and EN 61 000-3-2, EN 61 000-3-3, EN 50 082-1, (EN 61 000-4-2, EN 61 000-4-3, EN 61 000-4-4)** THE TEST WAS CARRIED OUT ON **Nov. 10, 1998** AT **SPORTON INTERNATIONAL INC. LAB.**

Lenore Chang Nov. 19, 1998

Lenore Chang
President



SPORTON LAB.

Certificate No: C882605

CERTIFICATE

Equipment Under Test : IPC with CPU Board & LCD Panel

Model No. : IPC-610XX, PCM-3540T, PCM-3540R, PCM-3521

Applicant : **ADVANTECH CO., LTD.**

Fl. 4, No. 108-3, Ming-Chuan Road, Shing-Tien City,
Taipei, Taiwan, R.O.C.



CERTIFY THAT:

THE MEASUREMENTS SHOWN IN THIS TEST REPORT WERE MADE IN ACCORDANCE WITH THE PROCEDURES GIVEN IN **EUROPEAN COUNCIL DIRECTIVE 89/336/EEC**. THE EQUIPMENT WAS **PASSED** THE TEST PERFORMED ACCORDING TO **EUROPEAN STANDARD EN 55022/A1 Class A, and EN 61 000-3-2, EN 61 000-3-3, EN 50 082-1, (EN 61 000-4-2, EN 61 000-4-3, EN 61 000-4-4)**

THE TEST WAS CARRIED OUT ON **Nov. 10, 1998** AT **SPORTON INTERNATIONAL INC. LAB.**

Lenore Chang Nov. 19, 1998

Lenore Chang
President

CE TEST REPORT

according to

**European Standard EN 55 022:1994/A1:1995 Class A and
EN 61 000-3-2:1995, EN 61 000-3-3:1995, EN 50 082-1:1997,
(EN 61 000-4-2:1995, EN 61 000-4-3:1996, EN 61 000-4-4:1995)**

EQUIPMENT : IPC with CPU Board & LCD Panel

MODEL NO. : IPC-610XX, PCM-3540T, PCM-3540R, PCM-3521

APPLICANT : ADVANTECH CO., LTD.

**Fl. 4, No. 108-3, Ming-Chuan Road, Shing-Tien City,
Taipei, Taiwan, R.O.C.**

- The test result refers exclusively to the test presented test model / sample.
- Without the written authorization of the test lab., the Test Report may not be copied.

SPORTON INTERNATIONAL INC.

6F, No. 106, Hsin Tai Wu Rd., Sec. 1, Hsi Chih, Taipei Hsien, Taiwan, R.O.C.

TABLE OF CONTENT

SECTION TITLE	PAGE
CERTIFICATE OF COMPLIANCE	4
1. GENERAL DESCRIPTION OF EQUIPMENT UNDER TEST	5
1.1. APPLICANT.....	5
1.2. MANUFACTURER.....	5
1.3. BASIC DESCRIPTION OF EQUIPMENT UNDER TEST	5
1.4. FEATURE OF EQUIPMENT UNDER TEST	5
2. TEST CONFIGURATION OF EQUIPMENT UNDER TEST	6
2.1. TEST MANNER.....	6
2.2. DESCRIPTION OF TEST SYSTEM.....	6
3. TEST SOFTWARE.....	8
4. GENERAL INFORMATION OF TEST	9
4.1. TEST FACILITY.....	9
4.2. STANDARD FOR METHODS OF MEASUREMENT	9
4.3. TEST IN COMPLIANCE WITH	9
4.4. FREQUENCY RANGE INVESTIGATED.....	9
4.5. TEST DISTANCE	9
5. TEST OF CONDUCTED POWERLINE	10
5.1. DESCRIPTION OF MAJOR TEST INSTRUMENTS	10
5.2. TEST PROCEDURES	11
5.3. TYPICAL TEST SETUP LAYOUT OF CONDUCTED POWERLINE	12
5.4. TEST RESULT OF AC POWERLINE CONDUCTED EMISSION.....	13
6. TEST OF RADIATED EMISSION	14
6.1. DESCRIPTION OF MAJOR TEST INSTRUMENTS	14
6.2. TEST PROCEDURES	15
6.3. TYPICAL TEST SETUP LAYOUT OF RADIATED EMISSION.....	16
6.4. TEST RESULT OF RADIATED EMISSION	17
6.5. PHOTOGRAPHS OF RADIATED EMISSION TEST CONFIGURATION	18
7. HARMONICS TEST	19
7.1. STANDARD.....	19
7.2. TEST PROCEDURE.....	19
7.3. TEST EQUIPMENT SETTINGS :.....	19
7.4. TEST SETUP	19
7.5. CURRENT HARMONICS TEST.....	20
8. VOLTAGE FLUCTUATIONS TEST	22
8.1. STANDARD.....	22
8.2. TEST PROCEDURE.....	22
8.3. TEST EQUIPMENT SETTINGS :.....	22
8.4. TEST SETUP	22
8.5. TEST RESULT OF VOLTAGE FLUCTUATION AND FLICKER TEST.....	23
8.6. PHOTOGRAPHS OF HARMONICS TEST, VOLTAGE FLUCTUATION AND FLICKER TEST.....	25



9. ELECTROSTATIC DISCHARGE IMMUNITY TEST (ESD)..... 26

- 9.1. TEST SETUP26
- 9.2. TEST SETUP FOR TESTS PERFORMED IN LABORATORY27
- 9.3. ESD TEST PROCEDURE28
- 9.4. TEST SEVERITY LEVELS29
- 9.5. TEST POINTS30
- 9.6. PHOTOGRAPHS OF ELECTROSTATIC DISCHARGE (ESD) IMMUNITY TEST.....31

10. RADIO FREQUENCY ELECTROMAGNETIC FIELD IMMUNITY TEST (RS)..... 32

- 10.1. TEST SETUP32
- 10.2. TEST PROCEDURE.....33
- 10.3. TEST SEVERITY LEVELS34
- 10.4. PHOTO OF RADIO FREQUENCY ELECTROMAGNETIC FIELD IMMUNITY TEST.....35

11. ELECTRICAL FAST TRANSIENT/BURST IMMUNITY TEST (EFT/BURST)..... 36

- 11.1. TEST SETUP36
- 11.2. TEST ON POWER LINE.....37
- 11.3. TEST ON COMMUNICATION LINES37
- 11.4. TEST PROCEDURE.....38
- 11.5. TEST SEVERITY LEVELS39
- 11.6. PHOTO OF ELECTRICAL FAST TRANSIENT/BURST IMMUNITY TEST.....40

12. ANTENNA FACTOR & CABLE LOSS 42

13. LIST OF MEASURING EQUIPMENT USED 43

14. DECLARATION OF CONFORMITY AND THE CE MARK 45

APPENDIX A. Photographs of EUT A1-A12



CERTIFICATE OF COMPLIANCE

according to

**European Standard EN 55 022:1994/A1:1995 Class A and
EN 61 000-3-2:1995, EN 61 000-3-3:1995 , EN 50 082-1:1997,
(EN 61 000-4-2:1995, EN 61 000-4-3:1996, EN 61 000-4-4:1995)**

EQUIPMENT : IPC with CPU Board & LCD Panel

MODEL NO. : IPC-610XX, PCM-3540T, PCM-3540R, PCM-3521

APPLICANT : ADVANTECH CO., LTD.

**Fl. 4, No. 108-3, Ming-Chuan Road, Shing-Tien City,
Taipei, Taiwan, R.O.C.**

I HEREBY CERTIFY THAT :

The measurements shown in this test report were made in accordance with the procedures given in **EUROPEAN COUNCIL DIRECTIVE 89/336/EEC**. The equipment was **passed** the test performed according to

EUROPEAN STANDARD EN 55 022:1994/ A1:1995 Class A,

EN 61 000-3-2:1995, EN 61 000-3-3:1995 and

EN 50 082-1:1997(EN 61 000-4-2:1995, EN 61 000-4-3:1996, EN 61 000-4-4:1995)

The test was carried out on **Nov. 10, 1998** at **SPORTON INTERNATIONAL INC. LAB.**



Lenore Chang

President

SPORTON INTERNATIONAL INC.

6F, No. 106, Hsin Tai Wu Rd., Sec. 1, Hsi Chih, Taipei Hsien, Taiwan, R.O.C.



1. GENERAL DESCRIPTION OF EQUIPMENT UNDER TEST

1.1. APPLICANT

ADVANTECH CO., LTD.

Fl. 4, No. 108-3, Ming-Chuan Road, Shing-Tien City,

Taipei, Taiwan, R.O.C.

1.2. MANUFACTURER

Same as 1.1.

1.3. BASIC DESCRIPTION OF EQUIPMENT UNDER TEST

EQUIPMENT : IPC with CPU Board & LCD Panel

MODEL NO. : IPC-610XX, PCM-3540T, PCM-3540R, PCM-3521

TRADE NAME : **Advantech**

LCD DATA CABLE : Shielded

POWER SUPPLY TYPE : Switching

POWER CORD : Non-shielded

1.4. FEATURE OF EQUIPMENT UNDER TEST

- CPU : AMD, Am5×86-P75
- CPU Board : PCA-6155
- Base Board : PCA-6114P4
- VGA mode : 640×480, 31.5K

2. TEST CONFIGURATION OF EQUIPMENT UNDER TEST

2.1. TEST MANNER

- a. The DELL keyboard, HP printer and ACEEX modem×2 were connected to the EUT for EMI test. During testing, the interface cables and equipment positions were varied according to European Standard EN 55022.
- b. The DELL keyboard, HP printer and ACEEX modem were connected to the EUT for EMS test.

2.2. DESCRIPTION OF TEST SYSTEM

< EMI >

Support Device 1. --- KEYBOARD (DELL)

FCC ID : GYUM92SK
Model No. : AT101 (DE8M)
Serial No. : SP1021
Data Cable : Shielded, 360 degree via metal backshells, 1.9m

Support Device 2. --- PRINTER (HP)

FCC ID : B94C2642X
Model No. : DESK JET 400
Serial No. : SP1040
Data Cable : Shielded, 360 degree via metal backshells, 1.35m
Power Supply Type : Linear, Adapter
Power Cord : Non-shielded

Support Device 3. -- MODEM (ACEEX)

FCC ID : IFAXDM1414
Model No. : DM1414
Power Supply Type : Linear, AC Adapter
Power Cord : Non-shielded
Serial No. : SP1045
Data Cable : Shielded, 360 degree via metal backshells, 1.15m

< EMS >

Support Device 1. --- KEYBOARD (DELL)

FCC ID : GYUM92SK
Model No. : AT101 (DE8M)
Serial No. : SP1021
Data Cable : Shielded, 360 degree via metal backshells, 1.9m

Support Device 2. --- PRINTER (HP)

FCC ID : DS16XU2225
Model No. : 2225C
Serial No. : SP1041
Data Cable : Shielded, 360 degree via metal backshells, 1.35m
Power Supply Type : Linear, AC Adapter
Power Cord : Non-shielded

Support Device 3. -- MODEM (ACEEX)

FCC ID : IFAXDM1414
Model No. : DM1414
Power Supply Type : Linear, AC Adapter
Power Cord : Non-shielded
Serial No. : SP1045
Data Cable : Shielded, 360 degree via metal backshells, 1.15m

3. TEST SOFTWARE

An executive program, EMITEST.EXE under DOS, which generates a complete line of continuously repeating " H " pattern was used as the test software.

The program was executed as follows :

- a. Turn on the power of all equipment.
- b. The PC reads the test program from the floppy disk drive and runs it.
- c. The PC sends " H " messages to the monitor, and the monitor displays " H " patterns on the screen.
- d. The PC sends " H " messages to the printer, then the printer prints them on the paper.
- e. The PC sends " H " messages to the modem.
- f. The PC sends " H " messages to the internal Hard Disk, and the Hard Disk reads and writes the message.
- g. Repeat the steps from b to f.



4. GENERAL INFORMATION OF TEST

4.1. TEST FACILITY

This test was carried out by SPORTON INTERNATIONAL INC.

Openarea Test Site Location : No. 30-1, Lin 6, Diing-Fwu Tsuen, Lin-Kou-Hsiang,
Taipei Hsien, Taiwan, R.O.C.

TEL : 886-2-2601-1640,

FAX : 886-2-2601-1695

4.2. STANDARD FOR METHODS OF MEASUREMENT

EMI Test (conduction and radiation) : European Standard EN 55 022 Class A.

Harmonics Test : European Standard EN 61 000-3-2.

Voltage fluctuations Test : European Standard EN 61 000-3-3.

EMS Test (ESD, RS and EFT) : European Standard EN 50 082-1.

(ESD : EN 61 000-4-2, RS : EN 61 000-4-3, EFT : EN 61 000-4-4)

4.3 .TEST IN COMPLIANCE WITH

EMI Test (conduction and radiation) : European Standard EN 55 022 Class A.

Harmonics Test : European Standard EN 61 000-3-2.

Voltage fluctuations Test : European Standard EN 61 000-3-3.

EMS Test (ESD, RS and EFT) : European Standard EN 50 082-1.

(ESD : EN 61 000-4-2, RS : EN 61 000-4-3, EFT : EN 61 000-4-4)

4.4. FREQUENCY RANGE INVESTIGATED

a. Conducted emission test: from 150 KHz to 30 MHz

b. Radiated emission test: from 30 MHz to 1000 MHz

c. Radio frequency electromagnetic field immunity test : from 80 MHz to 1000 MHz.

4.5. TEST DISTANCE

The test distance of radiated emission test from antenna to EUT is 10 M.

The test distance of radio frequency electromagnetic field immunity test from antenna to EUT is 3 M.

5. TEST OF CONDUCTED POWERLINE

Conducted Emissions were measured from 150 KHz to 30 MHz with a bandwidth of 9 KHz on the 230 VAC power and return leads of the EUT according to the methods defined in European Standard EN 55022 Clause 9. The EUT was placed on a nonmetallic stand in a shielded room 0.8 meters above the ground plane as shown in Figure 5-3. The interface cables and equipment positioning were varied within limits of reasonable applications to determine the position producing maximum conducted emissions.

5.1. DESCRIPTION OF MAJOR TEST INSTRUMENTS

* Test Receiver	(HP 8591EM)
Attenuation	0 dB
Start Frequency	0.15 MHz
Stop Frequency	30 MHz
Step MHz	0.007 MHz
IF Bandwidth	9 KHz

5.2. TEST PROCEDURES

- a. The EUT was placed on a desk 0.8 meters height from the metal ground plane and 0.4 meter from the conducting wall of the shielding room and it was kept at least 0.8 meters from any other grounded conducting surface.
- b. Connect EUT to the power mains through a line impedance stabilization network (LISN).
- c. All the support units are connect to the other LISN.
- d. The LISN provides 50 ohm coupling impedance for the measuring instrument.
- e. The CISPR states that a 50 ohm , 50 microhenry LISN should be used.
- f. Both sides of AC line were checked for maximum conducted interference.
- g. The frequency range from 150 KHz to 30 MHz was searched.
- h. Set the test-receiver system to Peak Detect Function and Specified Bandwidth with Maximum Hold Mode.
- i. If the emission level of the EUT in peak mode was 6 dB lower than the limit specified, then testing will be stopped and peak values of EUT will be reported, otherwise, the emissions which do not have 6 dB margin will be retested one by one using the quasi-peak method and/or average methods and reported.



5.3. TYPICAL TEST SETUP LAYOUT OF CONDUCTED POWERLINE

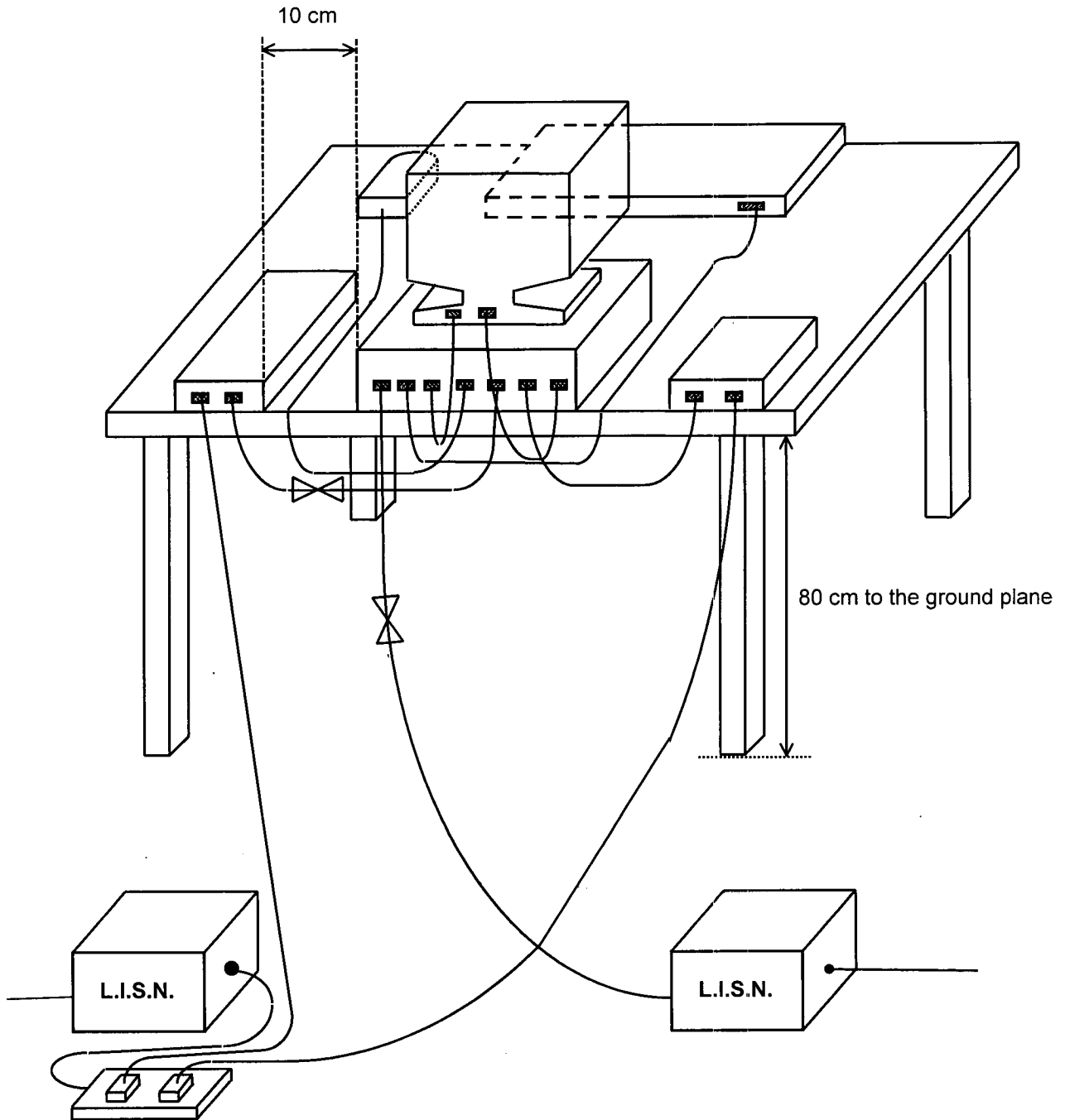



5.4. TEST RESULT OF AC POWERLINE CONDUCTED EMISSION

- Equipment meets the technical specifications of EN 55 022 (1994)
- Frequency Range of Test : from 0.15 MHz to 30 MHz
- Temperature : 22°C
- Relative Humidity : 53% RH
- Test Date : Nov. 05, 1998

The Conducted Emission test was passed at Line 6.29 MHz/ 56.00 dBuV.

Frequency (MHz)	Line or Neutral	Meter Reading				Limits				Margin	
		Q.P. (dBuV)	A.V. (dBuV)	Q.P. (uV)	A.V. (uV)	Q.P. (dBuV)	A.V. (dBuV)	Q.P. (uV)	A.V. (uV)	Q.P. (dB)	A.V. (dB)
6.29	Line	56.00	49.70	630.96	305.49	73.00	60.00	4466.84	1000.00	-17.00	-10.30
9.44	Line	46.00	39.60	199.53	95.50	73.00	60.00	4466.84	1000.00	-27.00	-20.40
25.17	Line	52.80	52.60	436.52	426.58	73.00	60.00	4466.84	1000.00	-20.20	-7.40
6.29	Neutral	55.90	49.60	623.73	302.00	73.00	60.00	4466.84	1000.00	-17.10	-10.40
9.44	Neutral	46.80	40.40	218.78	104.71	73.00	60.00	4466.84	1000.00	-26.20	-19.60
25.17	Neutral	48.80	48.60	275.42	269.15	73.00	60.00	4466.84	1000.00	-24.20	-11.40

Test Engineer :

Kenny Chuang

Kenny Chuang

6. TEST OF RADIATED EMISSION

Radiated emissions from 30 MHz to 1000 MHz were measured with a bandwidth of 120 KHz according to the methods defines in European Standard EN 55022, Clause 10. The EUT was placed on a nonmetallic stand in the open-field site, 0.8 meter above the ground plane, as shown in Figure 6-3. The interface cables and equipment positions were varied within limits of reasonable applications to determine the positions producing maximum radiated emissions.

6.1. DESCRIPTION OF MAJOR TEST INSTRUMENTS

- Amplifier (HP 8447D)
 - Attenuation 0 dB
 - RF Gain 25 dB
 - Signal Input 0.1 MHz to 1.3 GHz

- Spectrum Analyzer (HP 8568B)
 - Attenuation 0 dB
 - Start Frequency 30 MHz
 - Stop Frequency 1000 MHz
 - Resolution Bandwidth 1 MHz
 - Video Bandwidth 1 MHz
 - Signal Input 100 Hz to 1.5 GHz

- Quasi-Peak Adapter (HP 85650A)
 - Resolution Bandwidth 120 KHz
 - Frequency Band 30 MHz to 1 GHz
 - Quasi-Peak Detector ON for Quasi-Peak Mode
OFF for Peak Mode

6.2. TEST PROCEDURES

- a. The EUT was placed on a rotatable table top 0.8 meter above ground.
- b. The EUT was set 10 meters from the interference receiving antenna which was mounted on the top of a variable height antenna tower.
- c. The table was rotated 360 degrees to determine the position of the highest radiation.
- d. The antenna is a half wave dipole and its height is varied between one meter and four meters above ground to find the maximum value of the field strength both horizontal polarization and vertical polarization of the antenna are set to make the measurement.
- e. For each suspected emission the EUT was arranged to its worst case and then tune the antenna tower (from 1 M to 4 M) and turn table (from 0 degree to 360 degrees) to find the maximum reading.
- f. Set the test-receiver system to Peak Detect Function and specified bandwidth with Maximum Hold Mode.
- g. If the emission level of the EUT in peak mode was 6 dB lower than the limit specified, then testing will be stopped and peak values of EUT will be reported, otherwise, the emissions which do not have 6 dB margin will be repeated one by one using the quasi-peak method and reported.

6.3. TYPICAL TEST SETUP LAYOUT OF RADIATED EMISSION

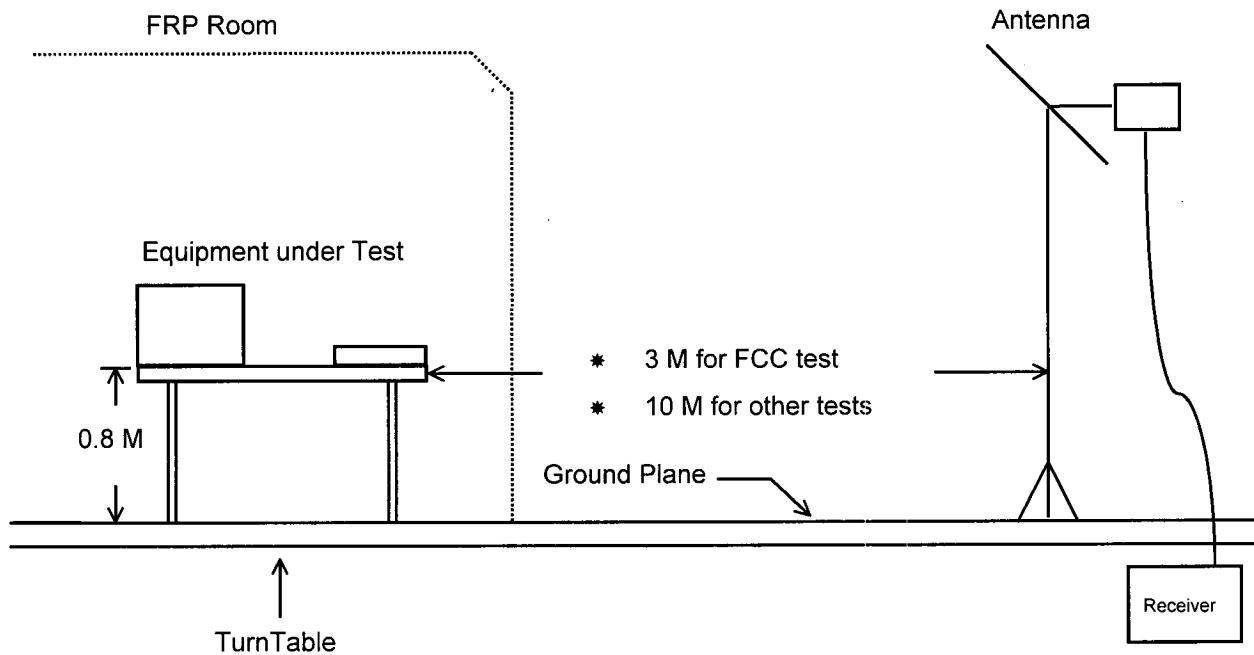

6.4. TEST RESULT OF RADIATED EMISSION

- Equipment meets the technical specifications of EN 55 022 (1994)
- Frequency Range of Test : from 30 MHz to 1000 MHz
- Test Distance : 10 M
- Temperature : 24°C
- Relative Humidity : 80 % RH
- Test Date : Nov. 04, 1998

- Emission level (dBuV/m) = 20 log Emission level (uV/m)
- Sample Calculation at 200.92 MHz
Corrected Reading = 9.11 + 2.31 + 24.57 = 35.99 (dBuV/m)

The Radiated Emission test was passed at

Vertical 226.11 MHz / 36.35 dBuV

Antenna Height 1.3 Meter , Turntable Degree 15°

Frequency (MHz)	Polarity	Antenna Factor (dB/m)	Cable Loss (dB)	Reading (dBuV)	Limits (dBuV/m)	Emission Level (uV/m)	Level (dBuV/m)	Margin (dB)
200.92	H	9.11	2.31	24.57	40.00	100	35.99	63.02 -4.01
226.11	H	9.60	2.50	23.56	40.00	100	35.67	60.74 -4.33
273.93	H	12.66	2.74	27.20	47.00	224	42.61	135.05 -4.39
125.71	V	11.46	2.09	22.28	40.00	100	35.82	61.80 -4.18
226.11	V	9.60	2.50	24.24	40.00	100	36.35	65.69 -3.65
276.32	V	12.75	2.76	27.26	47.00	224	42.77	137.56 -4.23

Test Engineer : James Jan
Jones Jan

6.5. PHOTOGRAPHS OF RADIATED EMISSION TEST CONFIGURATION

FRONT VIEW

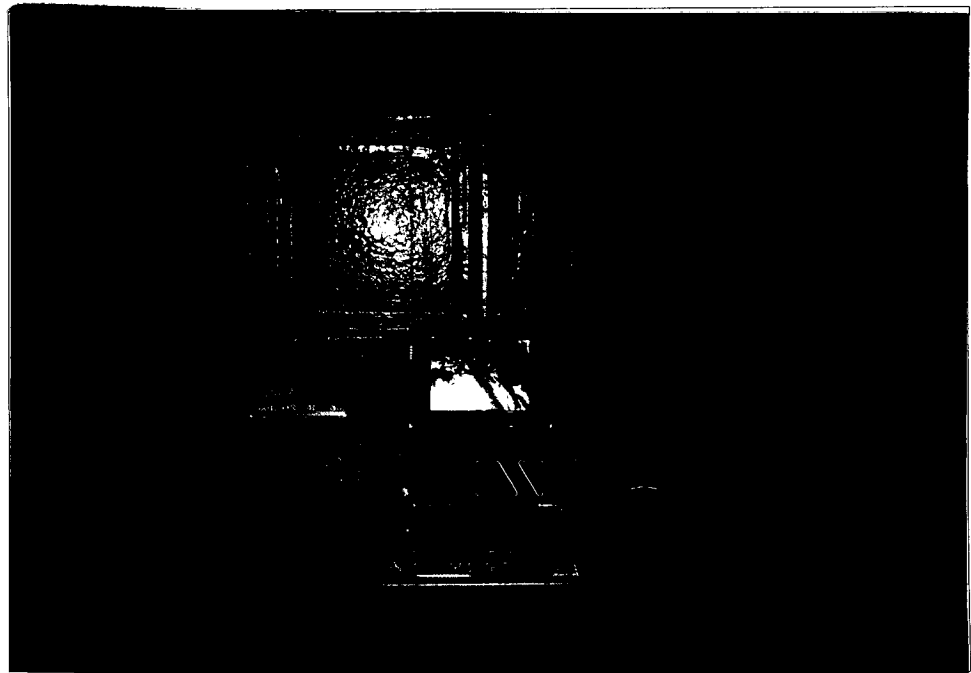

REAR VIEW

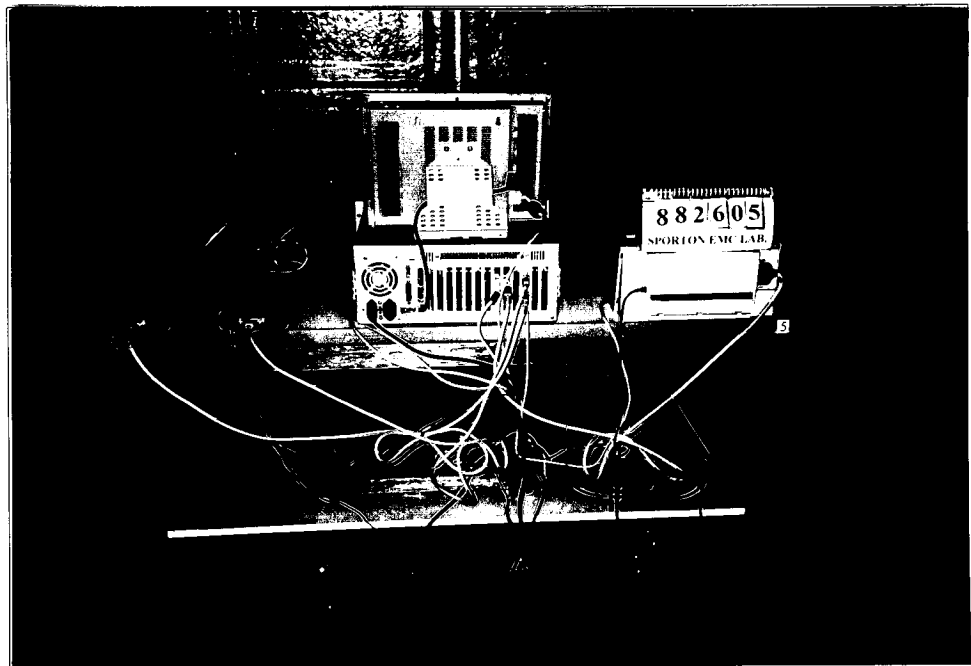

7. HARMONICS TEST

7.1. STANDARD

- Product Standard : EN 61 000-3-2 (1995)

7.2. TEST PROCEDURE

The measured values of the harmonics components of the input current, including line current and neutral current, shall be compared with the limits given in Clause 4.

7.3. TEST EQUIPMENT SETTINGS :

- Line Voltage : 230 V
- Line Frequency : 50 Hz
- Device Class : A
- Current Measurement Range : High
- Measurement Delay : 10.0 seconds
- Test Duration : 2.00 minutes
- Class determination Pre-test Duration : 10.00 seconds

7.4. TEST SETUP

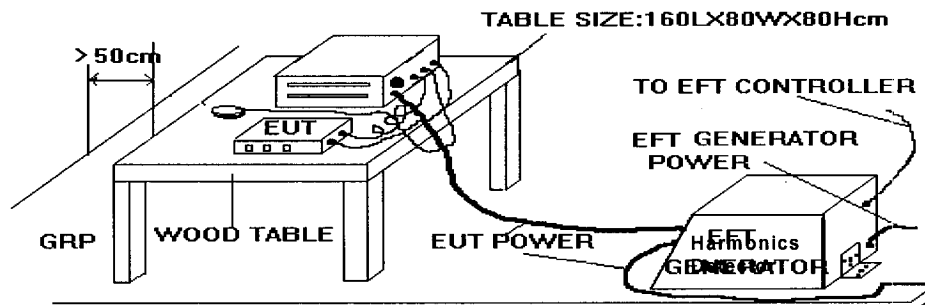



7.5. CURRENT HARMONICS TEST

7.5.1. TEST DATA OF CURRENT HARMONICS

- FINAL TEST RESULT : **PASS**
- Fundamental Current : 0.199 A
- Real Power : 38.6 W
- Power Factor : 0.352
- Percent in Envelope : 100.0 %
- Temperature : 21°C
- Relative Humidity : 62% RH
- Test Date : Nov. 09, 1998

Harmonic Number	Standard Limit (A rms)	Max. Span Values (A rms)	Harmonic Number	Standard Limit (A rms)	Max. Span Values (A rms)
1	Fund	0.1929	21	0.1070	0.0837
2	1.0800	0.0027	22	0.0840	0.0012
3	2.3000	0.1636	23	0.0980	0.0719
4	0.4300	0.0024	24	0.0770	0.0012
5	1.1400	0.1609	25	0.0900	0.0603
6	0.3000	0.0023	26	0.0710	0.0012
7	0.7700	0.1546	27	0.0830	0.0495
8	0.2300	0.0020	28	0.0660	0.0011
9	0.4000	0.1487	29	0.0780	0.0393
10	0.1840	0.0017	30	0.0610	0.0010
11	0.3300	0.1390	31	0.0730	0.0301
12	0.1530	0.0017	32	0.0580	0.0008
13	0.2100	0.1295	33	0.0680	0.0219
14	0.1310	0.0014	34	0.0540	0.0007
15	0.1500	0.1187	35	0.0640	0.0151
16	0.1150	0.0014	36	0.0510	0.0005
17	0.1320	0.1074	37	0.0610	0.0097
18	0.1020	0.0012	38	0.0480	0.0004
19	0.1180	0.0956	39	0.0580	0.0065
20	0.0920	0.0012	40	0.0460	0.0004

Test Engineer : Bruce Huang
 Bruce Huang



7.5.2. TEST GRAPH OF HARMONICS

Harmonics

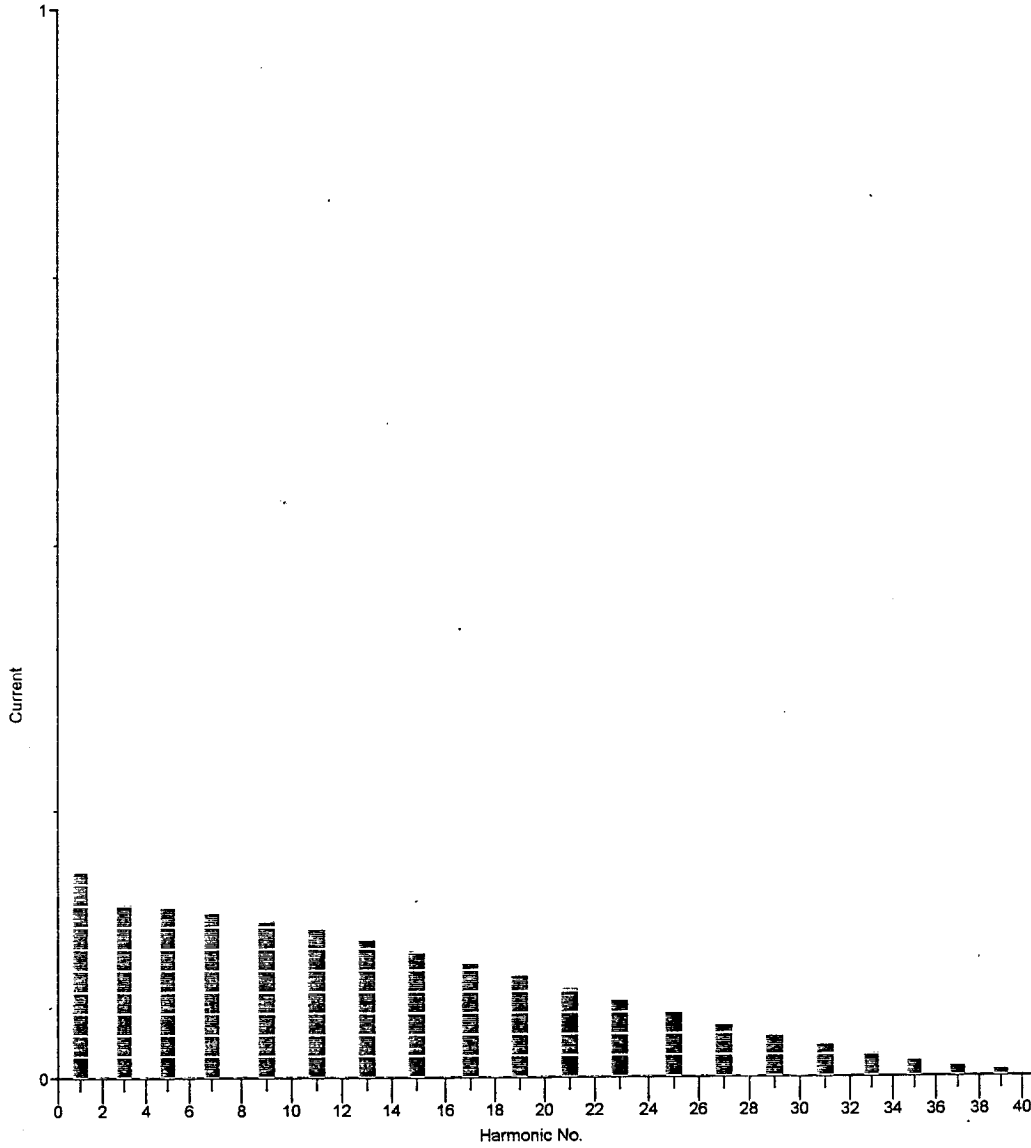

Span: 0:00:02:00.00

882605.STA

Cursor: 0:00:02:00.00

8. VOLTAGE FLUCTUATIONS TEST

8.1. STANDARD

- Product Standard : EN 61 000-3-3 (1995)

8.2. TEST PROCEDURE

The equipment shall be tested under the conditions of **Clause 5**.

The total impedance of the test circuit, excluding the appliance under test, but including the internal impedance of the supply source, shall be equal to the reference impedance. The stability and tolerance of the reference impedance shall be adequate to ensure that the overall accuracy of $\pm 8\%$ is achieved during the whole assessment procedure.

8.3. TEST EQUIPMENT SETTINGS :

- Line Voltage : 230 V
- Line Frequency : 50 Hz
- Measurement Delay : 10.0 seconds
- Pst Integration Time : 10 minutes
- Pst Integration Periods : 1
- Test Duration : 00:10:00 minutes

8.4. TEST SETUP

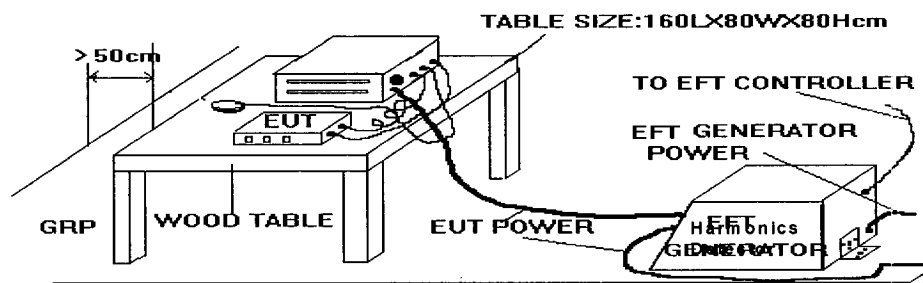



8.5. TEST RESULT OF VOLTAGE FLUCTUATION AND FLICKER TEST

8.5.1. TEST DATA OF VOLTAGE FLUCTUATION AND FLICKER

- FINAL TEST RESULT : **PASS**
- Temperature : 21°C
- Relative Humidity : 62% RH
- Test Date : Nov. 09, 1998

	Pst	Plt	Dc (%)	Dmax (%)	Dt (%)
Reading	0.073	0.00	0.00	0.00	0.00
Limit	0.65	1.0	3.0	4.0	3.0

Test Engineer : Bruce Huang
Bruce Huang



8.5.2. TEST GRAPH OF VOLTAGE FLUCTUATION AND FLICKER

Pst Histogram

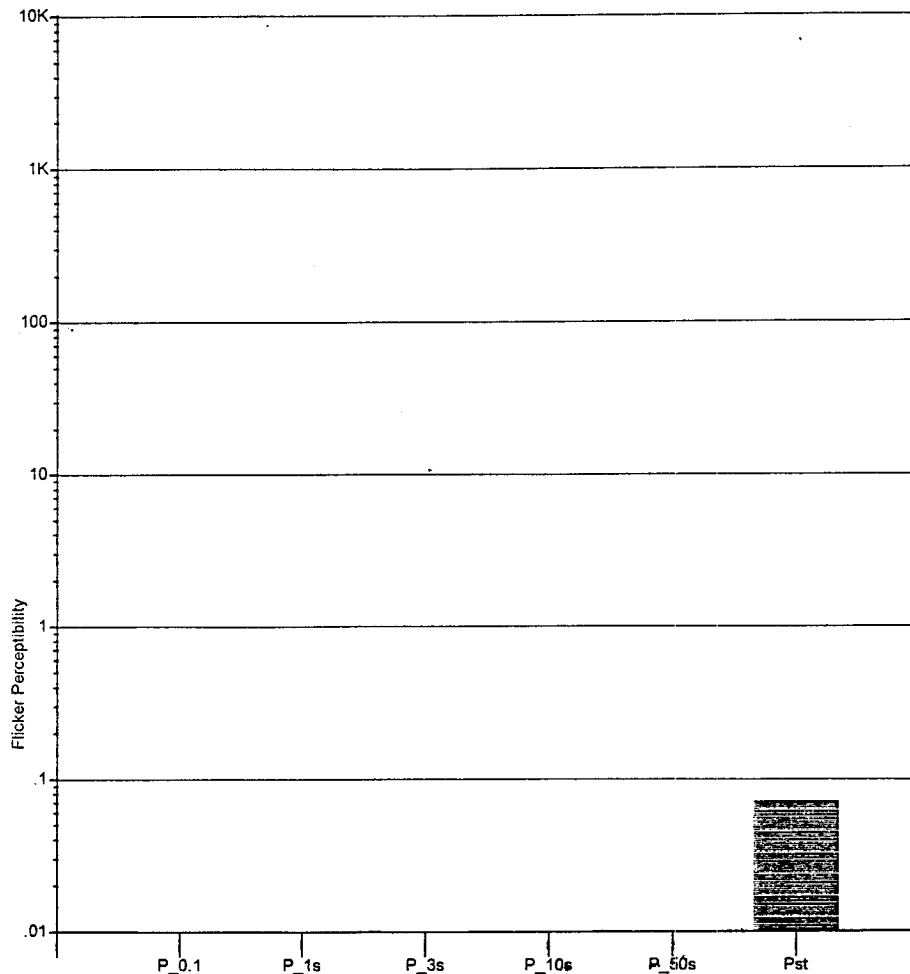

Pst

Span: 0:00:10:00.00

882605.FLK

Cursor: 0:00:10:00.00

8.6. PHOTOGRAPHS OF HARMONICS TEST, VOLTAGE FLUCTUATION AND FLICKER TEST

FRONT VIEW



REAR VIEW

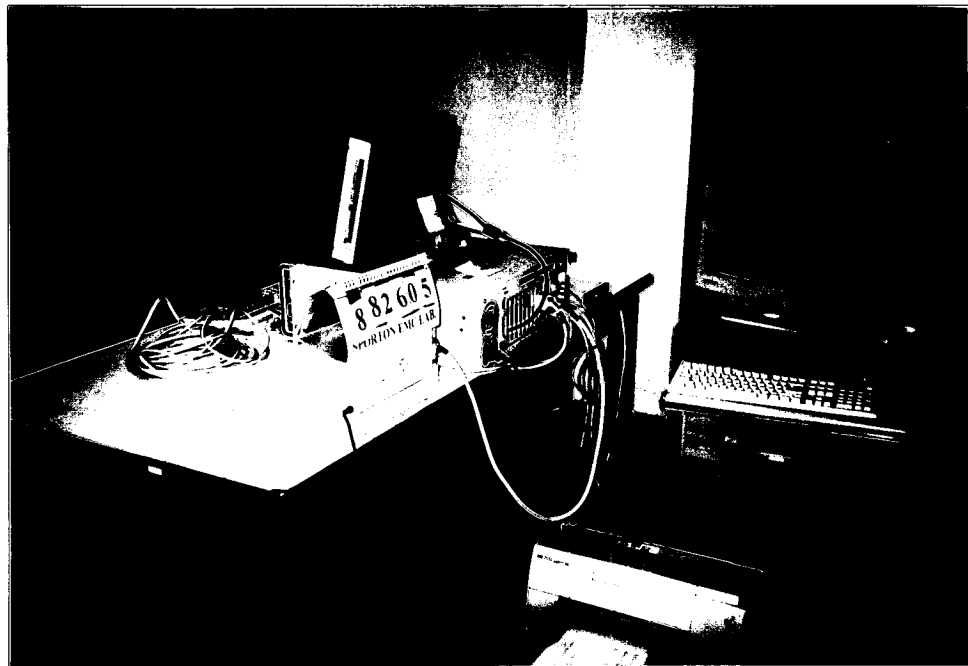



9. ELECTROSTATIC DISCHARGE IMMUNITY TEST (ESD)

FINAL TEST RESULT : PASS

- Basic Standard : EN 61 000-4-2 (1995)
- Generic Standard : EN 50 082-1 (1997)
- Performance Criteria : B
(Remark : During testing, at $\pm 8\text{KV}$ (air discharge), on the frame of the front panel the image shown on the panel flickered. After stopping testing it worked normally.)
- Level : 3 for Air discharge,
2 for Contact discharge
- Tested Voltage : $\pm 2 / \pm 4 / \pm 8 \text{KV}$ for Air discharge,
 $\pm 2 / \pm 4 \text{KV}$ for Contact discharge
- Temperature : 19°C
- Relative Humidity : 57 %
- Test Date : Nov. 10, 1998

9.1. TEST SETUP

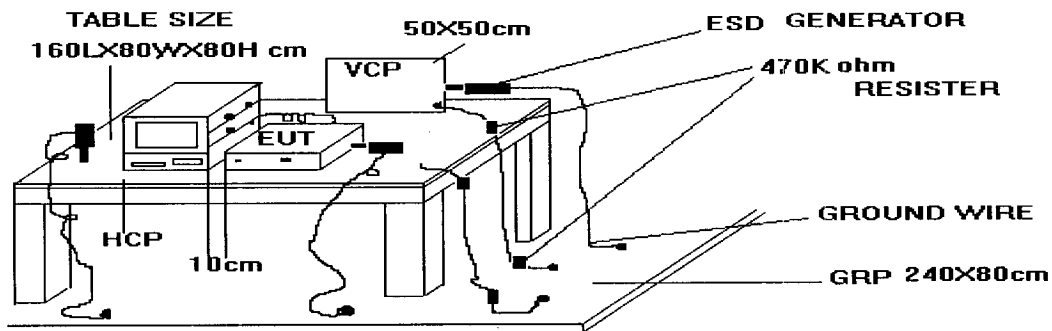

The test setup consists of the test generator, EUT and auxiliary instrumentation necessary to perform DIRECT and INDIRECT application of discharges to the EUT as applicable, in the follow manner :

- (a) CONTACT DISCHARGE to the conductive surfaces and to coupling plane;
- (b) AIR DISCHARGE at insulating surfaces.

The preferred test method is that of type tests performed in laboratories and the only accepted method of demonstrating conformance with this standard. The EUT was arranged as closely as possible to arrangement in final installed conditions.

9.2. TEST SETUP FOR TESTS PERFORMED IN LABORATORY

A ground reference plane was provided on the floor of the test site. It was a metallic sheet (copper or aluminum) of 0.25 mm ,minimum thickness; other metallic may be used but they shall have at least 0.65 mm thickness. In the SPORTON EMC LAB. we provided 1 mm thickness aluminum ground reference plane or 1 mm thickness stainless steel ground reference plane. The minimum size of the ground reference plane is 1 m x 1 m, the exact size depending on the dimensions of the EUT. It was connected to the protective grounding system.

The EUT was arranged and connected according to its functional requirements. A distance of 1m minimum was provided between the EUT and the wall of the lab. and any other metallic structure. In cases where this length exceeds the length necessary to apply the discharges to the selected points, the excess length shall , where possible, be placed non-inductively off the ground reference plane and shall not come closer than 0.2m to other conductive parts in the test setup.

Where the EUT is installed on a metal table, the table was connected to the reference plane via a cable with a 470k ohm resister located at each end, to prevent a build-up of charge. The test setup was consist a wooden table, 0.8m high, standing on the ground reference plane. A HCP, 1.6 m x 0.8 m, was placed on the table. The EUT and cables was isolated from the HCP by an insulating support 0.5 mm thick. The VCP size, 0.5 m x 0.5 m.

9.3. ESD TEST PROCEDURE

- a. In the case of air discharge testing the climatic conditions shall be within the following ranges:
 - ambient temperature : 15°C to 35°C;
 - relative humidity : 30% to 60%;
 - atmospheric pressure : 68 KPa (680 mbar) to 106 KPa (1060 mbar).
- b. Test programs and software shall be chosen so as to exercise all normal modes of operation of the EUT. The use of special exercising software is encouraged, but permitted only where it can be shown that the EUT is being comprehensively exercised.
- c. The test voltage shall be increased from the minimum to the selected test severity level, in order to determine any threshold of failure. The final severity level should not exceed the product specification value in order to avoid damage to the equipment.
- d. The test shall be performed with single discharges. On preselected points at least ten single discharges (in the most sensitive polarity) shall be applied.
- e. For the time interval between successive single discharges an initial value of one second is recommended. Longer intervals may be necessary to determine whether a system failure has occurred.
- f. In the case of contact discharges, the tip of the discharge electrode shall touch the EUT before the discharge switch is operated.
- g. In the case of painted surface covering a conducting substrate, the following procedure shall be adopted :
 - If the coating is not declared to be an insulating coating by the equipment manufacturer, then the pointed tip of the generator shall penetrate the coating so as to make contact with the conducting substrate.
 - Coating declared as insulating by the manufacturer shall only be submitted to the air discharge.
 - The contact discharge test shall not be applied to such surfaces.
- h. In the case of air discharges, the round discharge tip of the discharge electrode shall be approached as fast as possible (without causing mechanical damage) to touch the EUT . After each discharge, the ESD generator (discharge electrode) shall be removed from the EUT. The generator is then retriggered for a new single discharge. This procedure shall be repeated until the discharges are completed. In the case of an air discharge test, the discharge switch, which is used for contact discharge, shall be closed.

9.4. TEST SEVERITY LEVELS**9.4.1. Contact discharge**

Level	Test Voltage (KV) of Contact discharge
1	±2
2	±4
3	±6
4	±8
X	Specified

Remark : "X" is an open level.

9.4.2. Air discharge

Level	Test Voltage (KV) of Air Discharge
1	±2
2	±4
3	±8
4	±15
X	Specified

Remark : "X" is an open level.



9.5. TEST POINTS

9.5.1. TEST RESULT OF AIR DISCHARGE

TEST POINT	VOLTAGE	TESTED NO.	OBSERVATION	RESULT
CASE	±2 / ±4 / ±8 KV	BY 10	NORMAL	PASS
SCREW	±2 / ±4 / ±8 KV	BY 10	NORMAL	PASS
BRACKET	±2 / ±4 / ±8 KV	BY 10	NORMAL	PASS
FAN	±2 / ±4 / ±8 KV	BY 10	NORMAL	PASS
PRINTER PORT	±2 / ±4 / ±8 KV	BY 10	NORMAL	PASS
COM1 PORT	±2 / ±4 / ±8 KV	BY 10	NORMAL	PASS
POWER INPUT	±2 / ±4 / ±8 KV	BY 10	NORMAL	PASS
LINE OUT	±2 / ±4 / ±8 KV	BY 10	NORMAL	PASS

9.5.2. TEST RESULT OF CONTACT DISCHARGE

POLARITY	VOLTAGE	TESTED NO.	OBSERVATION	RESULT
HORIZONTAL(AT FRONT)	±2 / ±4 KV	BY 10	NORMAL	PASS
HORIZONTAL (AT LEFT)	±2 / ±4 KV	BY 10	NORMAL	PASS
HORIZONTAL (AT RIGHT)	±2 / ±4 KV	BY 10	NORMAL	PASS
HORIZONTAL (AT REAR)	±2 / ±4 KV	BY 10	NORMAL	PASS
VERTICAL (AT FRONT)	±2 / ±4 KV	BY 10	NORMAL	PASS
VERTICAL (AT LEFT)	±2 / ±4 KV	BY 10	NORMAL	PASS
VERTICAL (AT RIGHT)	±2 / ±4 KV	BY 10	NORMAL	PASS
VERTICAL (AT REAR)	±2 / ±4 KV	BY 10	NORMAL	PASS
CASE	±2 / ±4 KV	BY 10	NORMAL	PASS
SCREW	±2 / ±4 KV	BY 10	NORMAL	PASS
BRACKET	±2 / ±4 KV	BY 10	NORMAL	PASS
PRINTER PORT	±2 / ±4 KV	BY 10	NORMAL	PASS
COM1 PORT	±2 / ±4 KV	BY 10	NORMAL	PASS

Test Engineer : Bruce Huang
 Bruce Huang

9.6. PHOTOGRAPHS OF ELECTROSTATIC DISCHARGE (ESD) IMMUNITY TEST

FRONT VIEW



REAR VIEW

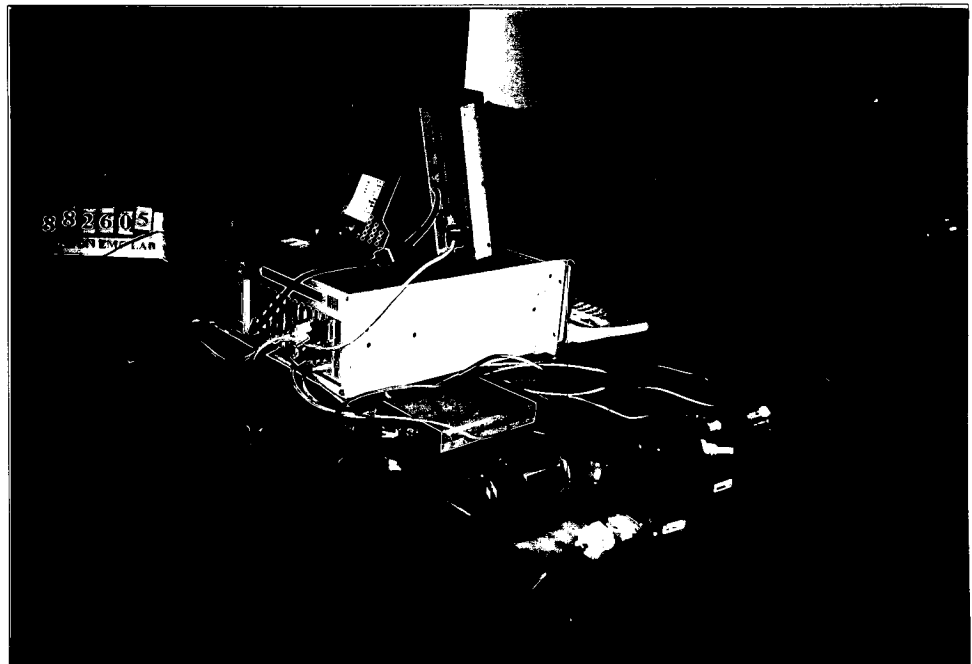

10. RADIO FREQUENCY ELECTROMAGNETIC FIELD IMMUNITY TEST (RS)

FINAL TEST RESULT : PASS

- Basic Standard : EN 61 000-4-3 (1996)
- Generic Standard : EN 50 082-1 (1997)
- Performance Criteria : A
- Level : 2
- Frequency Range : 80 to 1000 MHz
- Field Strength : 3 V/m
(Modulated 80 % AM)
- Temperature : 20°C
- Relative Humidity : 63 %
- Test Date : Nov. 10, 1998

10.1. TEST SETUP

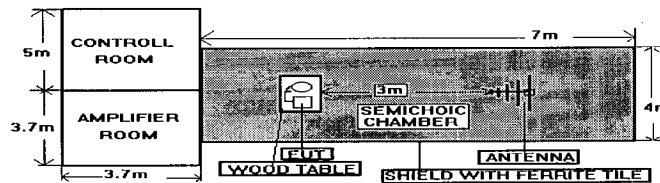

NOTE : The SPORTON 7m x 4m x 4m semicoic chamber is compliance with the sixteen points uniform field requirement as stated in IEC 1000-4-3 Section 6.2

The procedure defined in this part requires the generation of electromagnetic fields within which the test sample is placed and its operation observed. To generate fields that are useful for simulation of actual (field) conditions may require significant antenna drive power and the resultant high field strength levels. To comply with local regulations and to prevent biological hazards to the testing personnel, it is recommended that these tests be carried out in a shielded enclosure or semicoic chamber.

10.2. TEST PROCEDURE

- a. The equipment to be tested is placed in the center of the enclosure on a wooden table. The equipment is then connected to power and signal leads according to pertinent installation instructions.
- b. The bilog antenna which is enabling the complete frequency range of 80 MHz to 1000 MHz is placed 3m away from the equipment. The required field strength is determined by placing the field strength meter(s) on top of or directly alongside the equipment under test and monitoring the field strength meter via a remote field strength indicator outside the enclosure while adjusting the continuous-wave to the applicable antennae.
- c. The test is normally performed with the antenna facing the most sensitive side of the EUT. The polarization of the field generated by the biconical antenna necessitates testing each position twice, once with the antenna positioned vertically and again with the antenna positioned horizontally. The circular polarization of the field from the log-spiral antenna makes a change of position of the antenna unnecessary.
- d. At each of the above conditions, the frequency range is swept from 80 MHz to 1000 MHz, pausing to adjust the R.F. signal level or to switch oscillators and antenna. The rate of sweep is in the order of 1.5×10^{-3} decades/s. The sensitive frequencies or frequencies of dominant interest may be discretely analyzed.



10.3. TEST SEVERITY LEVELS

Frequency Band : 80 MHz to 1000 MHz

Level	Test field strength (V/m)
1	1
2	3
3	10
X	Specified

Remark : "X" is an open class.

Test Engineer : Bruce Huang
Bruce Huang



10.4. PHOTO OF RADIO FREQUENCY ELECTROMAGNETIC FIELD IMMUNITY TEST

FRONT VIEW

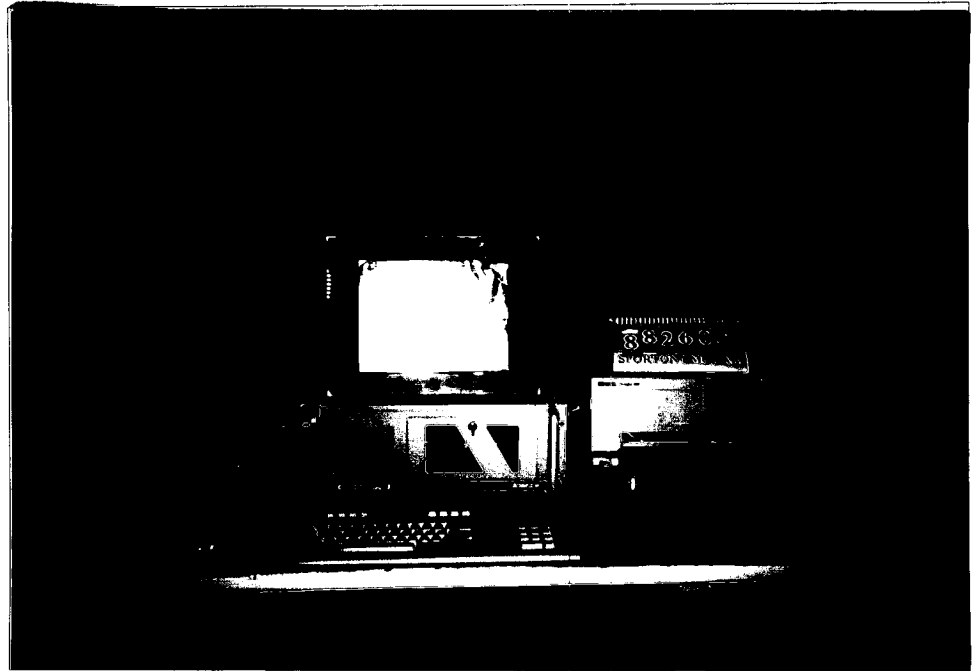

REAR VIEW

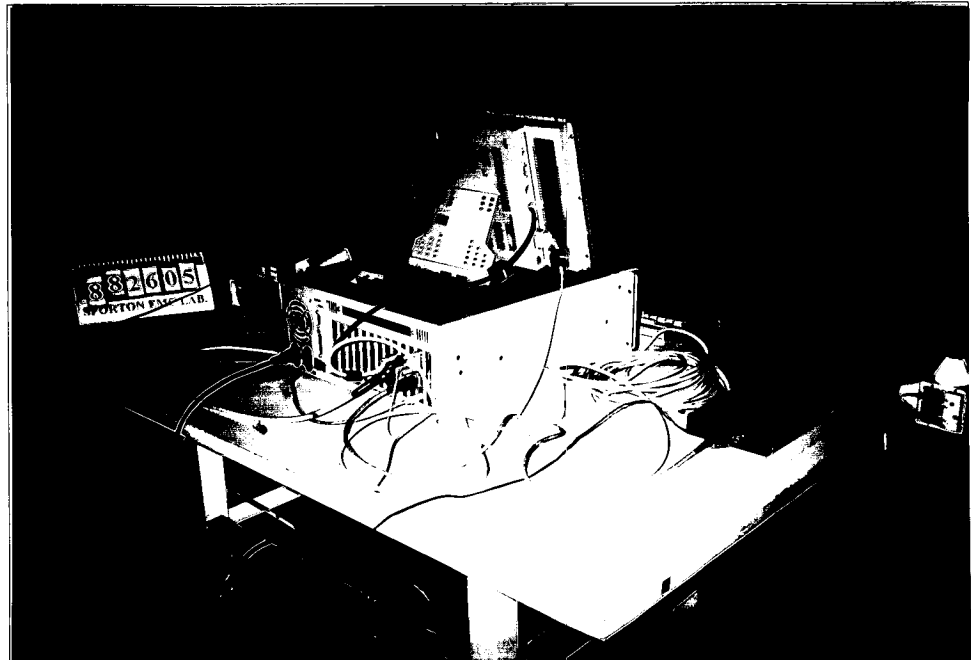

11. ELECTRICAL FAST TRANSIENT/BURST IMMUNITY TEST (EFT/BURST)**FINAL TEST RESULT : PASS**

- Basic Standard : EN 61 000-4-4 (1995)
- Generic Standard : EN 50 082-1 (1997)
- Performance Criteria : B
(Remark : During testing, the image shown on the LCD Panel flickered. After stopping testing it worked normally.)
- Level : on Power Supply -- 2
on I/O signal, data and control line -- 2
- Test Voltage : on Power Supply -- $\pm 0.5 / 1.0$ KV
on I/O signal, data and control line -- 0.25 / 0.50 KV
- Temperature : 21°C
- Relative Humidity : 62 %
- Test Date : Nov. 10, 1998

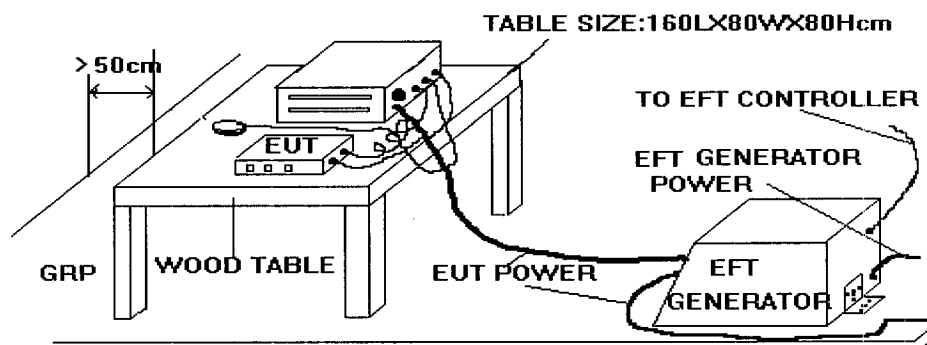
11.1. TEST SETUP

The EUT was placed on a ground reference plane and was insulated from it by an insulating support about 0.1m thick. If the EUT is table-top equipment, it was located approximately 0.8m above the GRP.. The GRP. was a metallic sheet (copper or aluminum) of 0.25 mm ,minimum thickness; other metallic may be used but they shall have at least 0.65 mm thickness. It shall project beyond the EUT by at least 0.1m on all sides and connected to the protective earth. In the SPORTON EMC LAB. we provided 1 mm thickness aluminum ground reference plane or 1 mm thickness stainless steel ground reference plane. The minimum size of the ground reference plane is 1 m x 1 m, the exact size depending on the dimensions of the EUT. It was connected to the protective grounding system. The EUT was arranged and connected according to its functional requirements. The minimum distance between the EUT and other conductive structures, except the GRP. beneath the EUT, was more than 0.5 m. Using the coupling clamp, the minimum distance between the coupling plates and all other conductive structures, except the GRP. beneath the EUT, was more than 0.5 m. The length of the signal and power lines between the coupling device and the EUT was 1m or less.

11.2. TEST ON POWER LINE

- a. The EFT/B-generator was located on the GRP.. The length from the EFT/B-generator to the EUT as not exceed 1 m.
- b. The EFT/B-generator provides the ability to apply the test voltage in a non-symmetrical condition to the power supply input terminals of the EUT.

11.3. TEST ON COMMUNICATION LINES

- a. The coupling clamp is composed of a clamp unit for housing the cable (length more than 3 m), and was placed on the GRP..
- b. The coupling clamp provides the ability of coupling the fast transient/bursts to the cable under test.



11.4. TEST PROCEDURE

- a. In order to minimize the effect of environmental parameters on test results, the climatic conditions when test is carrying out shall comply with the following requirements :
 - ambient temperature : 15°C to 35°C;
 - relative humidity : 45% to 75%;
 - atmospheric pressure : 68 KPa (680 mbar) to 106 KPa (1060 mbar).

- b. In order to minimize the effect of environmental parameters on test results, the electromagnetic environment of the laboratory shall not influence the test results.

- c. The variety and diversity of equipment and systems to be tested make it difficult to establish general criteria for the evaluation of the effects of fast transients/bursts on equipment and systems.

- d. The test results may be classified on the basic of the operating conditions and the functional specification of the equipment under test, according to the following performance criteria :
 - Normal performance within the specification limits.
 - Temporary degradation or loss of function or performance which is selfrecoverable.
 - Temporary degradation or loss of function or performance which requires operator intervention or system reset.
 - Degradation or loss of function which is not recoverable due to damage of equipment (components).



11.5. TEST SEVERITY LEVELS

The following test severity levels are recommended for the fast transient/burst test :

Open circuit output test voltage $\pm 10\%$		
Level	On Power Supply	On I/O signal, data and control line
1	0.5 KV	0.25 KV
2	1.0 KV	0.50 KV
3	2.0 KV	1.00 KV
4	4.0 KV	2.00 KV
X	Specified	Specified

Remark : " X " is an open level. The level is subject to negotiation between the user and the manufacturer or is specified by the manufacturer.

Test Engineer : Bruce Huang
Bruce Huang

11.6. PHOTO OF ELECTRICAL FAST TRANSIENT/BURST IMMUNITY TEST

FRONT VIEW

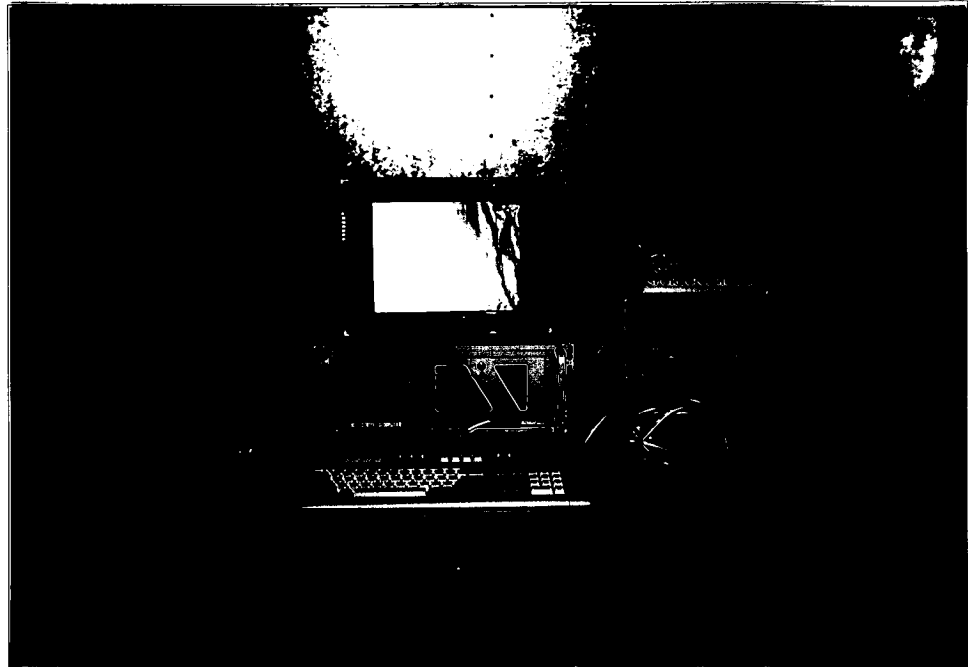

REAR VIEW

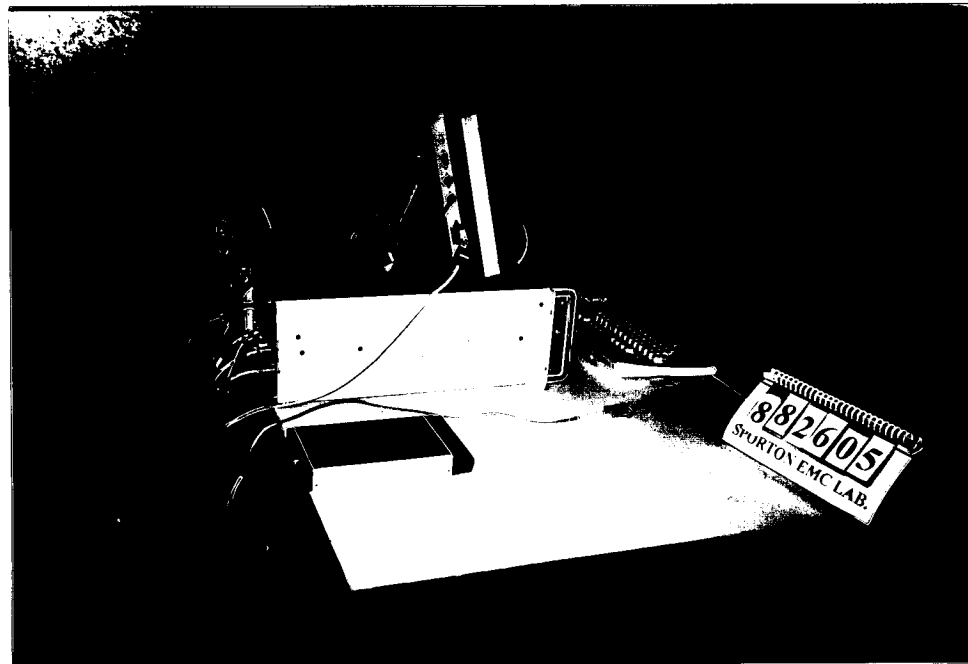

CLAMP

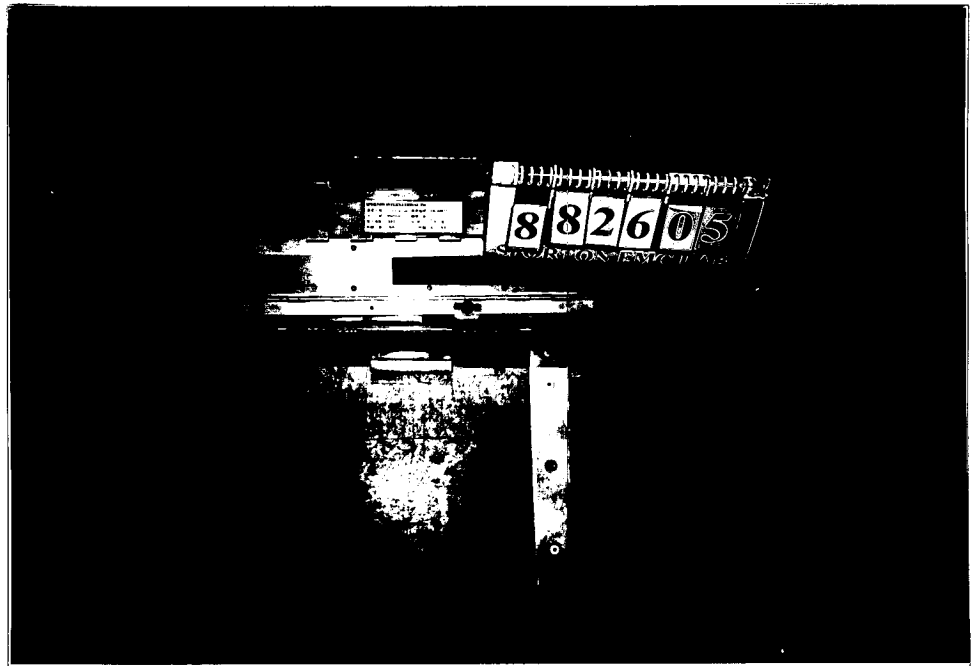

**12. ANTENNA FACTOR & CABLE LOSS**

Frequency (MHz)	Antenna Factor (dB)	Cable Loss (dB)
30	17.7	0.9
35	15.6	1.1
40	13.0	1.0
45	10.1	1.2
50	8.0	1.2
55	6.4	1.2
60	6.1	1.2
65	5.9	1.4
70	6.4	1.3
75	6.3	1.5
80	7.2	1.5
85	7.5	1.6
90	8.5	1.6
100	10.1	1.7
110	10.4	1.9
120	11.8	1.8
130	11.2	2.3
140	11.7	2.0
150	11.9	2.2
160	10.5	2.1
180	9.0	2.0
200	9.1	2.3
225	9.5	2.5
250	11.8	2.6
300	13.6	2.9
350	14.8	3.1
400	16.3	3.4
450	17.3	3.7
500	17.7	3.7
550	19.5	3.9
600	20.0	4.1
650	20.4	4.3
700	21.0	4.6
750	21.4	4.9
800	22.1	4.8
850	22.9	5.0
900	22.7	5.1
950	24.1	5.3
1000	24.9	5.5

13. LIST OF MEASURING EQUIPMENT USED
[CE-EMI]

Instrument	Manufacturer	Model No.	Serial No.	Characteristics	Calibration Date	Remark
EMC Receiver (site 2)	HP	8591EM	3710A01187	9 KHz - 18 GHz	Sep. 15, 1998	Conduction
LISN (EUT) (site 2)	Telemeter	NNB-2/16Z	98009	50 ohm / 50 uH	Jan. 29, 1998	Conduction
LISN (Support Unit) (site 2)	EMCO	3810/2NM	9703-1839	50 ohm / 50 uH	Jul. 06, 1998	Conduction
Quasi-peak Adapter (site 5)	HP	85650A	2521A00821	9KHz -1 GHz	Nov. 12, 1997	Radiation
Spectrum Analyzer (Site 5)	HP	8568B	2634A03000	100Hz - 1.5GHz	Nov. 12, 1997	Radiation
Amplifier (Site 5)	HP	8447D	2944A09073	0.1MHz -1.3GHz	Dec. 20, 1997	Radiation
Bilog Antenna (Site 5)	CHASE	CBL6112A	2287	30MHz -2GHz	Jan. 27, 1998	Radiation
Half-wave dipole antenna (Site 5)	EMCO	3121C	9705-1285	28 M - 1GHz	May 19, 1998	Radiation
Turn Table (site 5)	EMCO	2080	9711-2021	0 ~ 360 degree	N/A	Radiation
Antenna Mast (site 5)	EMCO	2075	9711-2115	1 m- 4 m	N/A	Radiation

※ The column of Remark indicates that the instruments used for conduction ("C") or radiation ("R") test.

[CE-EMS]

Instrument	Manufacturer	Model No.	Characteristics	Calibration Date	Remark
ESD Simulator	KEYTEK	DN-10	N/A	Mar. 27, 1998	ESD
ESD Simulator	KEYTEK	ESD-1	0 KV - 25 KV	Mar. 27, 1998	ESD
OMNI-Tip	KEYTEK	TPC-2	0 KV - 15 KV	Jul. 24, 1998	ESD
Amplifier	AR	100W 1000M3	80 MHz - 1 GHz	N/A	RS
Isotropic Field Probe	AR	FP3000A	10 KHz - 1 GHz	Jun. 20, 1998	RS
IEEE-488 Interface	AR	CP3000	N/A	N/A	RS
System Interface	EMC Automation	200	HP-IB INTERFACE	N/A	RS
Power Meter	EMC Automation	438A	100 KHz -4.2 GHz	N/A	RS
Video Camera controller	EMC Automation	VCC-01	N/A	N/A	RS
Signal Generator	HP	8648A	100 KHz - 1 GHz	Sep. 11, 1998	RS
Signal Generator	R&S	SMX	100 KHz - 1 GHz	Nov. 08, 1998	RS
Antenna	CHASE	CBL6121A	26 MHz - 1 GHz	Jun. 13, 1998	RS
Amplifier	AR	75W 75A220	25MHz - 300MHz	Jun. 15, 1998	RS
EFT Generator	KEYTEK	CE-40	0 KV - 4.4 KV	Jul. 10, 1998	EFT
Capacitive Clamp	KEYTEK	CE-40-CCL	0 KV - 2 KV	Jun. 24, 1998	EFT
Harmonic/Flicker Test System	HP	6843A	4800VA 90A / 48A PEAK	Nov. 15, 1997	Harmonics, Flicker

14. DECLARATION OF CONFORMITY AND THE CE MARK

There are three possible procedures pertaining to the declaration of conformity :

14.1. Conformity testing and declaration of conformity by the manufacturer or his authorized representative established within the Community or by an importer.

- Article 10 (1) of the EMC Directive,
- § 3 (1) no. 2a of the EMC Act.

14.2. Declaration of conformity issued by the manufacturer or his authorized representative established within the Community or by an importer following testing of the product and issued of an *EC certificate of conformity by a competent body.*

- Article 10 (2) of the EMC Directive,
- § 3 (1) no. 2b of the EMC Act.

14.3. Declaration of conformity issued by the manufacturer or his authorized representative established within the Community or by an importer following *testing and certification of the product by a notified body.*

- Article 10 (5) of the EMC Directive,
- § 3 (1) no. 2b of the EMC Act (radio transmitting installations).

14.4. Specimen For The CE Marking Of Electrical / Electronical Equipment

The components of the CE marking shall have substantially the same vertical dimension, which may not be less than 5 mm.



APPENDIX A. Photographs of EUT

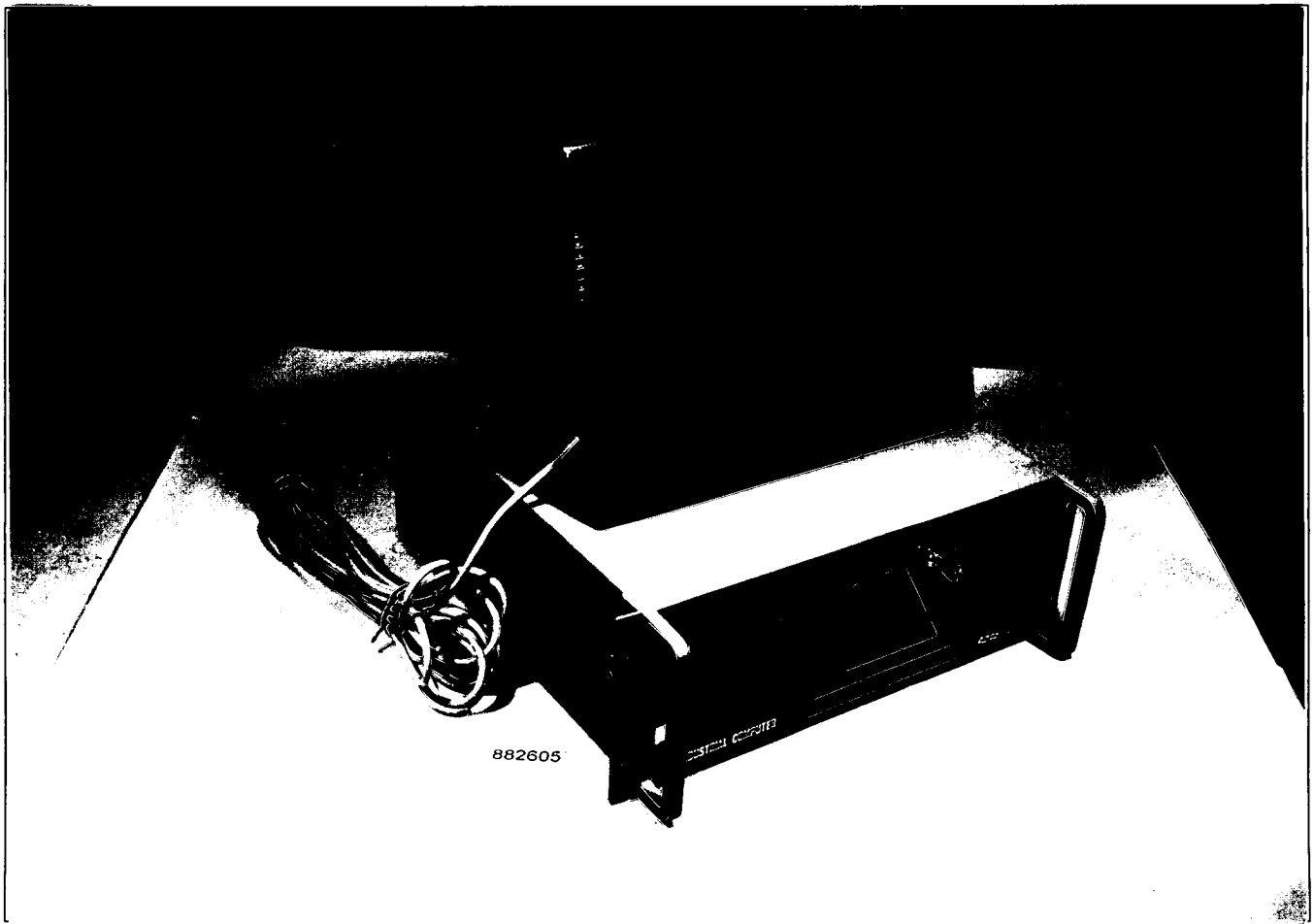

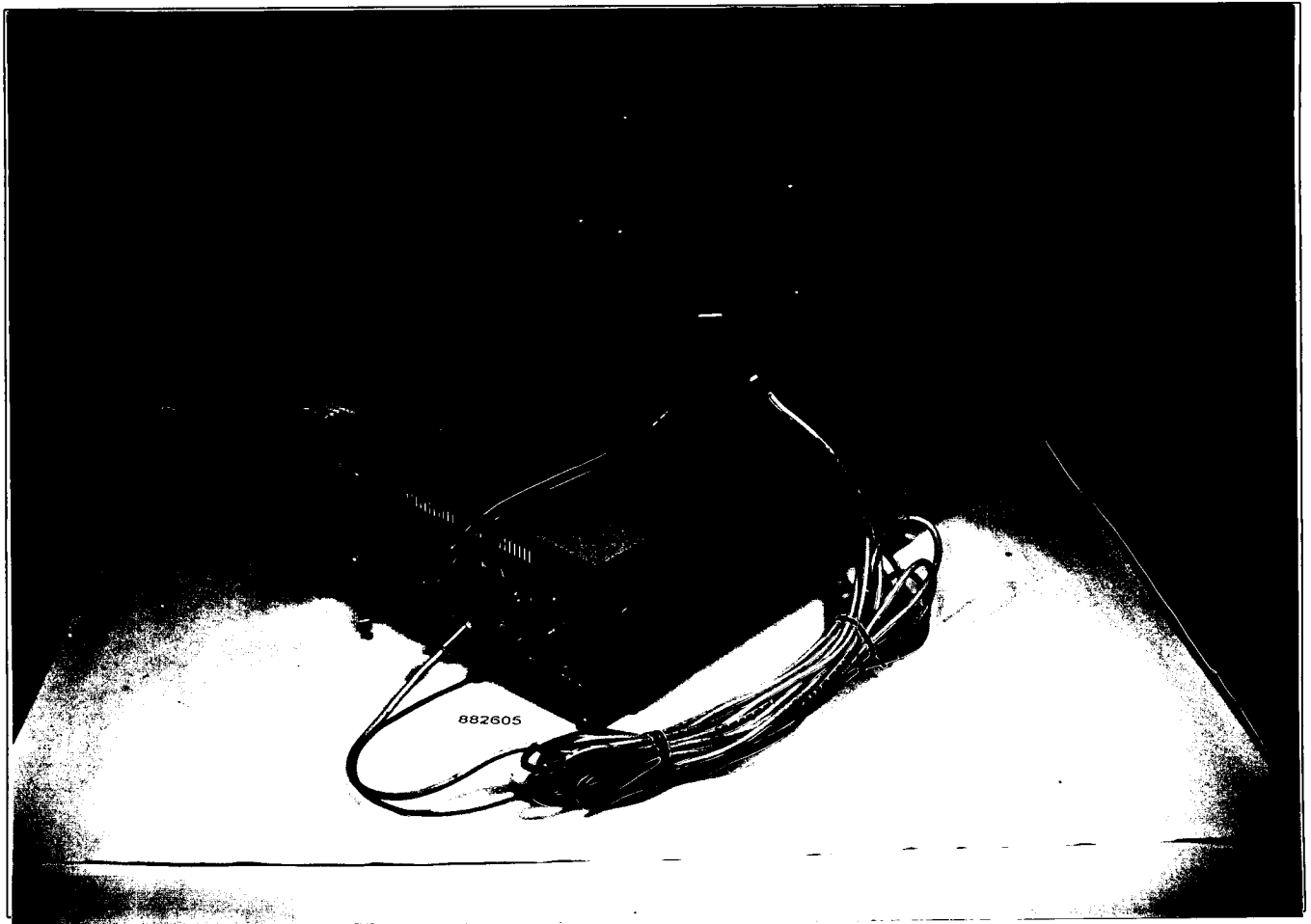

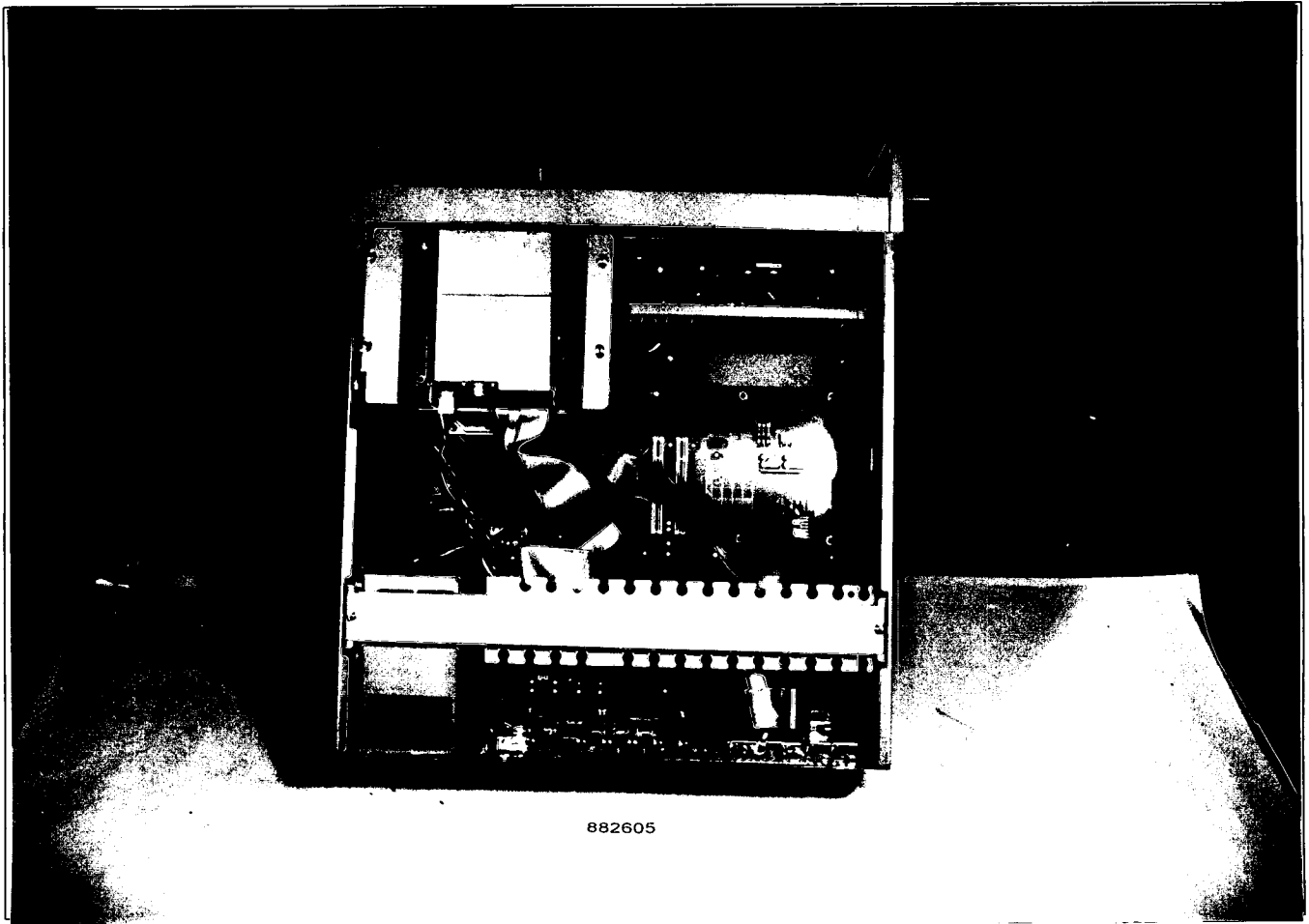

882605

