



CE EMC

TEST REPORT

For

Smart Medical Terminal

Model: ONYX-217; ONYX-215

Trade Name: AAEON

Issued to

AAEON Technology Inc.

**5F, No. 135, Lane 235, Pao Chiao Rd., Hsin-Tien City,
Taipei, Taiwan, R.O.C.**

Issued by



**Compliance Certification Services Inc.
Hsintien Lab.**

**No. 165, Chungsen Road, Hsintien City
Taipei Hsien, Taiwan**

TEL: (02) 2217-0894

FAX: (02) 2217-1029

Note: This report shall not be reproduced except in full, without the written approval of Compliance Certification Services Inc. Ltd. This document may be altered or revised by Compliance Certification Services Inc. personnel only, and shall be noted in the revision section of the document.



TABLE OF CONTENTS

1 TEST RESULT CERTIFICATION..... 3

2 EUT DESCRIPTION..... 4

3 TEST METHODOLOGY 5

3.1 EUT SYSTEM OPERATION 5

4 SETUP OF EQUIPMENT UNDER TEST 6

5 FACILITIES AND ACCREDITATIONS 7

5.1 FACILITIES..... 7

5.2 LABORATORY ACCREDITATIONS AND LISTINGS 7

6 INSTRUMENT AND CALIBRATION 8

6.1 MEASURING INSTRUMENT CALIBRATION 8

6.2 TEST AND MEASUREMENT EQUIPMENT 8

7 LINE CONDUCTED & RADIATED EMISSION TEST..... 11

7.1 LIMIT11

7.2 TEST PROCEDURE OF LINE CONDUCTED EMISSION..... 12

7.3 TEST PROCEDURE OF RADIATED EMISSION 14

7.4 TEST RESULTS 16

8 POWER HARMONICS TEST..... 18

9 POWER VOLTAGE FLUCTUATION / FLICKER TEST 20

10 ELECTROSTATIC DISCHARGE (ESD) IMMUNITY TEST..... 22

11 RADIATED ELECTROMAGNETIC FIELD IMMUNITY TEST..... 26

12 FAST TRANSIENTS/BURST IMMUNITY TEST 28

13 SURGE IMMUNITY TEST..... 30

**14 CONDUCTED DISTRBANCE/INDUCED RADIO-FREQUENCY FIELD
IMMUNITY TEST 32**

15 POWER FREQUENCY MAGNETIC FIELD IMMUNITY TEST..... 34

16 VOLTAGE DIPS / SHORT INTERRUPTIONS 36

APPENDIX I - PHOTOGRAPHS OF TEST SETUP 39

APPENDIX II – TEST RESULT OF EN 61000-3-3 46



1 TEST RESULT CERTIFICATION

Applicant: AAEON Technology Inc.
5F, No.135, Lane 235, Pao Chiao Rd., Hsin-Tien City,
Taipei, Taiwan, R.O.C.

Manufacturer: AAEON Technology Inc.
5F, No.135, Lane 235, Pao Chiao Rd., Hsin-Tien City,
Taipei, Taiwan, R.O.C.

Equipment Under Test: Smart Medical Terminal

Trade Name: AAEON

Model: ONYX-217; ONYX-215

Detailed EUT Description: See Item 2 of this report

Date of Test: February 24, 2006 ~ March 7, 2006

Applicable Standard	Class/Limit/Criterion	Test Result
EN 60601-1-2: 2001, including		
EN 55011: 1998 + A1: 1999 + A2: 2002	Group I, Class B	No non-compliance noted
IEC 61000-4-2: 1995 +A1: 1998 +A2: 2000	See Item 9 of this report	No non-compliance noted
IEC 61000-4-3: 2002 +A1: 2002	See Item 10 of this report	No non-compliance noted
IEC 61000-4-4: 1995 +A1: 2000 +A2: 2001	See Item 11 of this report	No non-compliance noted
IEC 61000-4-5: 1995 + A1: 2000	See Item 12 of this report	No non-compliance noted
IEC 61000-4-6: 1996 + A1: 2000	See Item 13 of this report	No non-compliance noted
IEC 61000-4-8: 1993 + A1: 2000	See Item 14 of this report	No non-compliance noted
IEC 61000-4-11: 1994 + A1: 2000	See Item 15 of this report	No non-compliance noted
EN 61000-3-2: 2000	Class D	N/A
EN 61000-3-3: 1995 + A1: 2001	Limit	No non-compliance noted
Deviation from Applicable Standard		
None		

The above equipment was tested by Compliance Certification Services Inc. for compliance with the requirements set forth in the EMC Directive 93/42/EEC and the technical standards mentioned above. The results of testing in this report apply only to the product/system, which was tested. Other similar equipment will not necessarily produce the same results due to production tolerance and measurement uncertainties.

Approved by:

David Wang
 Manager of Hsintien Laboratory
 Compliance Certification Services Inc.

Reviewed by:

Vince Chiang
 Assistant Manager of Hsintien Laboratory
 Compliance Certification Services Inc.



2 EUT DESCRIPTION

Product	Smart Medical Terminal
Trade Name	AAEON
Model	ONYX-217; ONYX-215
Housing Type	Plastic
EUT Power Rating	12VDC from AC Adaptor
AC Power During Test	230VAC / 50Hz to AC Adaptor
AC Adaptor Manufacturer	EDAC
AC Adaptor Model Number	EA1050A-120
AC Adaptor Power Rating	I/P: 100-240VAC, 50-60Hz O/P: 12VDC
AC Power Cord Type	Unshielded, 1.8m (Detachable)
DC Power Cord Type	Unshielded, 1.2m (Non-detachable, with a core)
OSC/Clock Frequencies	30MHz; 12MHz; 32.768kHz

EUT DIFFERENCE

	Model Name	Differences	Tested (Checked)
Original	ONYX-217	17" TFT LCD	<input checked="" type="checkbox"/>
Additional	ONYX-215	15" TFT LCD	<input checked="" type="checkbox"/>

I/O PORT OF EUT

I/O PORT TYPE	Q'TY	TESTED WITH
1). VIDEO IN Port (VGA)	1	1
2). VIDEO IN Port (DVI)	1	1
3). AUDIO IN Port	1	1
4). USB Port	4	4
5). SD Slot	1	1
6). SM Slot	1	1
7). MS Slot	1	1
8). CF Slot	1	1

Note: None.



3 TEST METHODOLOGY

3.1 EUT SYSTEM OPERATION

1. Windows XP boots system.
2. Run Emctest.exe to activate all peripherals and display “H” pattern on monitor screen.
3. Run Winemc.exe and choose media player to play music.
4. Run Winemc.exe then select “E:/ & F:/ & G:/ & H:/ & I:/ & J:/ & K:/” to test USB 2.0 Ports.

Note: Test program is self-repeating throughout the test.

3.2 DECISION OF FINAL TEST MODE

1. The following test mode(s) were scanned during the preliminary test:

Mode(s):

1	ONYX-217	D-SUB / 1280X1024, VF=60Hz
2		D-SUB / 800X600, VF=75Hz
3		DVI / 1280X1024, VF=60Hz
4		DVI / 800X600, VF=75Hz
5	ONYX-215	D-SUB / 1024X768, VF=60Hz
6		D-SUB / 800X600, VF=75Hz
7		DVI / 1024X768, VF=60Hz
8		DVI / 800X600, VF=75Hz

2. After the preliminary scan, the following test mode was found to produce the highest emission level.

Conduction: Mode 5

Radiation: Mode 1

Then, the EUT configuration and cable configuration of the above highest emission mode was chosen for all final test items.



4 SETUP OF EQUIPMENT UNDER TEST

Setup Diagram

See test photographs attached in Appendix I for the actual connections between EUT and support equipment.

Support Equipment

Peripherals Devices:

No	Equipment	Model	Serial No.	FCC ID/ BSMI ID	Trade Name	Data Cable	Power Cord
1	USB 2.0 HDD	F12-U	N/A	BSMI ID: 4912A002	TeraSys	Shielded, 1.8m	N/A
2	USB 2.0 HDD	F12-U	N/A	BSMI ID: 4912A002	TeraSys	Shielded, 1.8m	N/A
3	USB 2.0 HDD	F12-U	N/A	BSMI ID: 4912A002	TeraSys	Shielded, 1.8m	N/A
4	PS/2 Mouse	M071KC	443029438	BSMI: R41108 DoC	DELL	Shielded, 1.8m	N/A
5	PS/2 Keyboard	SK-8110	N/A	BSMI: T3A002 DoC	DELL	Shielded, 1.8m	N/A
6	Printer	C60	N/A	BSMI ID: 3902E006	EPSON	Shielded, 1.8 m	Unshielded, 1.8m
7	Host PC	P Evo D510C	7308-KN8Z-0010	BSMI ID: 3912Q007	COMPAQ	DVI: Shielded, 1.8m with two cores D-SUB: Shielded, 1.8m with two cores Audio: Unshielded, 1.8m USB: Shielded, 1.8m	Unshielded, 1.8m
8	Modem	5JEG4033MKO	N/A	5RJTAI-35500-M5-E	TOP-SOLUTION	Shielded, 1.1 m	Unshielded, 1.8m
9	SD Card	N/A	N/A	N/A	N/A	N/A	N/A
10	SM Card	N/A	N/A	N/A	N/A	N/A	N/A
11	MS Card	N/A	N/A	N/A	N/A	N/A	N/A
12	CF Card	N/A	N/A	N/A	N/A	N/A	N/A

Note: All the above equipment/cables were placed in worse case positions to maximize emission signals during emission test.
Grounding: Grounding was in accordance with the manufacturer's requirements and conditions for the intended use.

5 FACILITIES AND ACCREDITATIONS

5.1 FACILITIES







All measurement facilities (except above 1GHz measurement frequency of IEC 61000-4-3) used to collect the measurement data are located at CCS Taiwan Hsintien Lab at No. 165, Chunghsen Road, Hsintien City, Taipei Hsien, Taiwan.

The measurement facilities of IEC 61000-4-3 frequency rang above 1GHz are located at CCS Taiwan Wuku Lab. at No. 11, Wu-Kung 6 Rd., Wu-Ku Hsiang, Wu-Ku Industrial District, Taipei Hsien, Taiwan

5.2 LABORATORY ACCREDITATIONS AND LISTINGS

The test facilities used to perform Electromagnetic compatibility tests are registered or accredited by the organizations listed in the following table which includes the recognized scope specifically.

This accredited organization maintains A2LA accreditation to ISO/IEC 17025 for the specific test listed in A2LA Certificate # 0824-01. The test results included in this report, however, are not covered by this accreditation.

Country	Agency	Scope of Accreditation	Logo
USA	A2LA	CFR 47, FCC Part 15/18; AS/NZS 3548; VCCI V3; CNS 13438; CNS 13439; CNS 13783; CNS 14115; CISPR 11/EN 55011; CISPR 14-1/EN 55014-1; CISPR 15/EN 55015; CISPR 22/EN 55022; EN 50081-1/EN 61000-6-3; EN 50082-1/EN 61000-6-4; IEC/EN 61000-4-2, IEC/EN 61000-4-3, IEC/EN 61000-4-4, IEC/EN 61000-4-5, IEC/EN 61000-4-6, IEC/EN 61000-4-8, IEC/EN 61000-4-11, IEC/EN 61000-3-2, IEC/EN 61000-3-3; CISPR 24/EN 55024; CISPR 14-2/EN 55014-2; EN 50081-2/EN 61000-6-1; EN 50082-2/EN 61000-6-2.	 ACCREDITED 824.01
USA	FCC	3/10 meter Open Area Test Sites to perform FCC Part 15/18 measurements	 250366
Japan	VCCI	3/10 meter Open Area Test Sites and Line Conducted Test Room to perform conducted/radiated measurements	 R-1434/1630~4 C-1511/1882
Norway	NEMKO	EN 50081-1/2, EN 50082-1/2, IEC 61000-6-1/2/3/4, EN 50091-2, EN 50130-4, EN 55011, EN 55013, EN 55014-1/2, EN 55015, EN 55022, EN 55024, EN 61000-3-2/3, EN 61326-1, IEC 61000-4-2/3/4/5/6/8/11, Cspr 16-1/2/3/4	 ELA 103
Taiwan	CNLA	47 CFR FCC Part 15 Subpart B, EN 61000-3-2, EN 61000-3-3, CNS 13439, CNS 13783-1, CNS 13438, AS/NZS 3548, VCCI, CNS 13022-1/2/3, EN 55022, EN 55013, EN 55014-1, EN 61000-4-2/3/4/5/6/8/11, ENV 50204, ENV 50141, ENV 50142	 Testing Laboratory 1108
Taiwan	BSMI	CNS 13438, CNS 13783-1, CNS 13439	 SL2-IN-E-0005 SL2-A1-E-0005 SL2-R1-E-0005 SL2-R2-E-0005
Canada	Industry Canada	RSS212, Issue 1	 IC 5742

Note: No part of this report may be used to claim or imply product endorsement by CNLA, A2LA or other government agency.



6 INSTRUMENT AND CALIBRATION

6.1 MEASURING INSTRUMENT CALIBRATION

The measuring equipment utilized to perform the tests documented in this report has been calibrated once a year or in accordance with the manufacturer's recommendations, and is traceable to recognized national standards.

6.2 TEST AND MEASUREMENT EQUIPMENT

The following list contains measurement equipment used for testing. The equipment conforms to the requirement of CISPR 16-1, ANSI C63.2 and other required standards.

Calibration of all test and measurement, including any accessories that may effect such calibration, is checked frequently to ensure the accuracy. Adjustments are made and correction factors are applied in accordance with the instructions contained in the respective manual.

Equipment Used for Emission Measurement

Open Area Test Site # I				
EQUIPMENT	MFR	MODEL	SERIAL NUMBER	CAL. DUE
SITE NSA	CCS	I Site	N/A	10/14/2006
MEASURE RECEIVER	SCHAFFNER	SCR3501	338	06/27/2006
SPECTRUM ANALYZER	ADVANTEST	R3132	120900008	No Calibration Required
ANTENNA	SCHAFFNER	CBL 6112B	2809	09/23/2006
AMPLIFIER	SCHAFFNER	CPA9231A	3626	10/08/2006
CABLE	BELDEN	9913	N-TYPE #12	02/17/2007
ATTENUATOR	MCL	UNAT-6	AT06-3	10/08/2006
THERMO-HYGRO METER	TFA	N/A	NO.2	11/02/2006

Note: The measurement uncertainty is less than +/- 3.36dB, which is evaluated as per the NAMAS NIS 81 and CISPR/A/291/CDV.

Conducted Emission Test Site # A				
EQUIPMENT	MFR	MODEL	SERIAL NUMBER	CAL. DUE
TEST RECEIVER	R&S	ESHS20	840455/006	02/06/2007
LISN (EUT)	SCHWARZBECK	NSLK 8127	8127382	01/02/2007
LISN	SOLAR	8012-50-R-24-BNC	8305114	01/02/2007
BNC CABLE	JYE BAO	RG-223/U	BNC A 2	10/08/2006
THERMO-HYGRO METER	TOP	HA-202	9303-1	02/22/2007

Note: The measurement uncertainty is less than +/- 2.83dB, which is evaluated as per the NAMAS NIS 81 and CISPR/A/291/CDV.



Power Harmonic & Voltage Fluctuation/Flicker Test Site (EN 61000-3-2&-3-3)			
Manufacturer/Type	Model No.	Serial No.	Cal. Due
Schaffner / Signal Conditioning Unit	CCN 1000-1	72122	12/01/2006
Schaffner / 5KVA AC Power Source	NSG 1007	55131	No Calibration Required
Protronix / Digital Power Meter	1201	201091	08/24/2006

Equipment Used for Immunity Measurement

ESD Test Site (EN 61000-4-2)			
Manufacturer/Type	Model No.	Serial No.	Cal. Due
Schaffner / ESD Simulator	NSG 438	129	04/20/2006
Sato / Aneroid Barometer	7610-20	89090	08/29/2006
TOP / Thermo-Hygro meter	HA-202	9303-1	02/22/2007

Radiated Electromagnetic Field Immunity Test Site (EN 61000-4-3)			
Manufacturer/Type	Model No.	Serial No.	Cal. Due
Calibration of Field	Chamber#RS	RS3H-7 / RS3V-7	07/01/2006
Agilent / Signal Generator	E4421B	MY43350597	05/16/2006
AR / Electric Field Probe	FP6001	305657	05/26/2006
Boonton / RF Voltmeter	9200B	328001AE	02/08/2007
BNC / Function Generator	625A	25451	02/08/2007
AR / Amplifier	100W1000M1	17564	No Calibration Required
Werlatone Inc. / Direction Coupler	C2630	4121	No Calibration Required
Frankonia / Broadband Antenna	BTA-M	030001M	No Calibration Required
TOP / Thermo-Hygro meter	HA-202	9303-2	02/22/2007

Fast Transients/Burst Test Site (EN 61000-4-4)			
Manufacturer/Type	Model No.	Serial No.	Cal. Due
Schaffner / EFT Generator	BEST EMC V2.3	200031A024SC	11/07/2006
Schaffner / Capacitive Clamp	N/A	N/A	No Calibration Required



Surge Immunity Test Site (EN 61000-4-5)			
Manufacturer/Type	Model No.	Serial No.	Cal. Due
Schaffner / Surger Generator	BEST EMC V2.3	200031A024SC	11/07/2006
Schaffner / Signal and Data Lines Coupling Network	CDN118	19328	No Calibration Required

CS test (EN 61000-4-6)			
Manufacturer/Type	Model No.	Serial No.	Cal. Due
Schaffner / RF Generator	NSG 2070-1	1061	08/03/2006
Schaffner / CDN	CDN M316	19600	08/02/2006
Schaffner / CDN	CDN M216	19294	08/02/2006
FCC / CDN	FCC-801-M3-16A	99122	08/02/2006
Schaffner / EM Clamp	KEMZ 801	19227	02/19/2007
Schaffner / CDN	CDN T002	15881	01/12/2007
FCC / CDN	FCC-801-T8-RJ45	04025	06/23/2006
Schaffner / Attenuator	INA2070-1	2061	No Calibration Required
FCC / CDN	FCC-801-T4-RJ45	04031	08/02/2006

Power Frequency Magnetic Field Immunity test (EN 61000-4-8)			
Manufacturer/Type	Model No.	Serial No.	Cal. Due
Schaffner / Induction Coil Interface	INA 21141	6009	No Calibration Required
Schaffner / 5KVA AC Power Source	NSG 1007	55131	No Calibration Required
CHY/ TRMS Clamp Meter	932C	2K0900285	10/16/2006
Sypris / Magnetic Field Meter	4080	0247	01/23/2007

Voltage Dips/Short Interruption and Voltage Variation Immunity test (EN 61000-4-11)			
Manufacturer/Type	Model No.	Serial No.	Cal. Due
Schaffner / Dips/Interruption/Variations Tester	BEST EMC V2.3	200031A024SC	11/07/2006
Protronix / Digital Power Meter	1201	201091	08/24/2006



7 LINE CONDUCTED & RADIATED EMISSION TEST

7.1 LIMIT

Maximum permissible level of Line Conducted Emission

Frequency (MHZ)	Class A (dB μ V)		Class B (dB μ V)	
	Quasi-peak	Average	Quasi-peak	Average
0.15 - 0.5	79	66	66 - 56	56 - 46
0.50 - 5.0	73	60	56	46
5.0 - 30.0	73	60	60	50

Note: The lower limit shall apply at the transition frequency.

Maximum permissible level of Radiated Emission measured at 10 meter

Frequency (MHZ)	Class A (dB μ V/m)	Class B (dB μ V/m)
	Quasi-peak	Quasi-peak
30 - 230	40	30
230 - 1000	47	37

Note: The lower limit shall apply at the transition frequency.



7.2 TEST PROCEDURE OF LINE CONDUCTED EMISSION

Procedure of Preliminary Test

- The EUT was set up as per the test configuration to simulate typical usage per the user's manual. When the EUT is a tabletop system, a wooden table with a height of 0.8 meters is used and is placed on the ground plane as per EN 55011 (see Test Facility for the dimensions of the ground plane used). When the EUT is floor-standing equipment, it is placed on the ground plane that has a 3-12 mm non-conductive covering to insulate the EUT from the ground plane.
- Support equipment, if needed, was placed as per EN 55011.
- All I/O cables were positioned to simulate typical actual usage as per EN 55011.
- The test equipment EUT installed received AC power, 230VAC/50Hz, through a Line Impedance Stabilization Network (LISN), which supplied power source and was grounded to the ground plane.
- All support equipment received power from a second LISN.
- The EUT test program was started. Emissions were measured on each current carrying line of the EUT using an EMI Test Receiver connected to the LISN powering the EUT.
- The Receiver scanned from 150kHz to 30MHz for emissions in each of the test modes.
- During the above scans, the emissions were maximized by cable manipulation.
- The test mode(s) described in Item 3.2 were scanned during the preliminary test.
- After the preliminary scan, we found the test mode described in Item 3.2 producing the highest emission level.
- The EUT configuration and cable configuration of the above highest emission levels were recorded for reference of the final test.

Procedure of Final Test

- EUT and support equipment were set up on the test bench as per the configuration with highest emission level in the preliminary test.
- A scan was taken on both power lines, Line 1 and Line 2, recording at least the six highest emissions. Emission frequency and amplitude were recorded into a computer in which correction factors were used to calculate the emission level and compare reading to the applicable limit. If EUT emission level was less -2dB to the Average limit in Q.P. mode, then the emission signal was re-checked using an Average detector.
- The test data of the worst-case condition(s) was recorded.



Data Sample:

Freq. MHz	Read Level dBuV	Factor dB	Level dBuV	Limit dBuV	Over Limit dB	Reading Type (P/Q/A)	Line (L1/L2)
x.xx	42.95	0.55	43.50	56	-12.50	Q	L1

- Freq. = Emission frequency in MHz
- Read Level = Uncorrected Analyzer/Receiver reading
- Factor = Insertion loss of LISN + Cable Loss
- Level = Read Level + Factor
- Limit = Limit stated in standard
- Over Limit = Reading in reference to limit
- P = Peak Reading
- Q = Quasi-peak Reading
- A = Average Reading
- L1 = Hot side
- L2 = Neutral side

Calculation Formula

Over Limit (dB) = Level (dBuV) – Limit (dBuV)



7.3 TEST PROCEDURE OF RADIATED EMISSION

Procedure of Preliminary Test

- The equipment was set up as per the test configuration to simulate typical usage per the user's manual. When the EUT is a tabletop system, a wooden turntable with a height of 0.8 meters is used which is placed on the ground plane. When the EUT is floor-standing equipment, it is placed on the ground plane that has a 3-12 mm non-conductive covering to insulate the EUT from the ground plane.
- Support equipment, if needed, was placed as per EN 55011.
- All I/O cables were positioned to simulate typical usage as per EN 55011.
- The EUT received AC power source, 230VAC/50Hz, from the outlet socket under the turntable. All support equipment received power from another socket under the turntable.
- The antenna was placed at 10 meter away from the EUT as stated in EN 55011. The antenna connected to the Spectrum Analyzer via a cable and at times a pre-amplifier would be used.
- The Analyzer / Receiver quickly scanned from 30MHz to 1000MHz. The EUT test program was started. Emissions were scanned and measured rotating the EUT to 360 degrees and positioning the antenna 1 to 4 meters above the ground plane, in both the vertical and the horizontal polarization, to maximize the emission reading level.
- The test mode(s) described in Item 3.2 were scanned during the preliminary test:
- After the preliminary scan, we found the test mode described in Item 3.2 producing the highest emission level.
- The EUT and cable configuration, antenna position, polarization and turntable position of the above highest emission level were recorded for the final test.

Procedure of Final Test

- EUT and support equipment were set up on the turntable as per the configuration with highest emission level in the preliminary test.
- The Analyzer / Receiver scanned from 30MHz to 1000MHz. Emissions were scanned and measured rotating the EUT to 360 degrees, varying cable placement and positioning the antenna 1 to 4 meters above the ground plane, in both the vertical and the horizontal polarization, to maximize the emission reading level.
- Recorded at least the six highest emissions. Emission frequency, amplitude, antenna position, polarization and turntable position were recorded into a computer in which correction factors were used to calculate the emission level and compare reading to the applicable limit and only Q.P. reading is presented.
- The test data of the worst-case condition(s) was recorded.



Data Sample:

Freq. MHz	Read Level dBuV	Factor dB/m	Level dBuV/m	Limit dBuV/m	Over Limit dB	Reading Type (P/Q/A)	Pol. (H/V)
x.xx	14.0	12.2	26.2	30	-3.8	Q	H

- Freq. = Emission frequency in MHz
- Read Level = Uncorrected Analyzer/Receiver reading
- Factor = Antenna Factor + Cable Loss + Attenuator (3/6/10dB) – Amplifier Gain
- Level = Read Level + Factor
- Limit = Limit stated in standard
- Over Limit = Reading in reference to limit
- P = Peak Reading
- Q = Quasi-peak Reading
- A = Average Reading
- H = Antenna Polarization: Horizontal
- V = Antenna Polarization: Vertical

Calculation Formula

Over Limit (dB) = Level (dBuV/m) – Limit (dBuV/m)



7.4 TEST RESULTS

Line Conducted Emission

Model: ONYX-215**Test Mode:** Mode 5**Temperature:** 21°C**Humidity:** 62% RH**Test Results:** Passed**Tested by:** MARK HSU

(The chart below shows the highest readings taken from the final data)

Six Highest Conducted Emission Readings							
Frequency Range Investigated				150 kHz to 30 MHz			
Freq (MHz)	Read Level (dBuV)	Factor (dB)	Level (dBuV)	Limit Line (dBuV)	Over Limit (dB)	Reading Type (P/Q/A)	Line (L1/L2)
0.178	53.53	0.13	53.66	64.59	-10.93	P	L1
3.436	47.52	0.29	47.81	56.00	-8.19	P	L1
3.436	36.92	0.29	37.21	46.00	-8.79	A	L1
0.178	51.69	0.13	51.82	64.59	-12.77	P	L2
3.025	48.07	0.27	48.34	56.00	-7.66	P	L2
3.025	34.60	0.27	34.87	46.00	-11.13	A	L2
3.436	52.17	0.29	52.46	56.00	-3.54	P	L2
3.436	41.49	0.29	41.78	46.00	-4.22	A	L2
3.740	48.32	0.31	48.63	56.00	-7.37	P	L2
3.740	38.18	0.31	38.49	46.00	-7.51	A	L2

NOTE: Those frequencies only show peak emission level because that was below the Average limit, so no need to check average anymore.



Radiated Emission

Model: ONYX-217

Test Mode: Mode 1

Temperature: 23°C

Humidity: 68% RH

Test Results: Passed

Tested by: MARK HSU

(The chart below shows the highest readings taken from the final data)

Six Highest Radiated Emission Readings							
Frequency Range Investigated				30 MHz to 1000 MHz at 10m			
Freq (MHz)	Read Level (dBuV)	Factor (dB/m)	Level (dBuV/m)	Limit Line (dBuV/m)	Over Limit (dB)	Reading Type (P/Q/A)	Pol. (H/V)
480.150	34.00	-1.60	32.40	37.00	-4.60	Q	V
192.019	35.00	-11.18	23.82	30.00	-6.18	Q	H
240.030	37.50	-8.19	29.31	37.00	-7.69	Q	H
480.112	32.50	-1.60	30.90	37.00	-6.10	Q	H
720.043	27.60	1.86	29.46	37.00	-7.54	Q	H
960.229	30.10	5.72	35.82	37.00	-1.18	Q	H

NOTE: None.



8 POWER HARMONICS TEST

Port : AC Power Port
Basic Standard : EN 61000-3-2 (2000)
Limits : CLASS A; CLASS B; CLASS C; CLASS D
Tested by : N/A
Temperature : N/A
Humidity : N/A

Limit:

Limits for Class A equipment		Limits for Class D equipment		
Harmonics Order n	Max. permissible harmonics current A	Harmonics Order n	Max. permissible harmonics current per watt mA/W	Max. permissible harmonics current A
Odd harmonics		Odd Harmonics only		
3	2.30	3	3.4	2.30
5	1.14	5	1.9	1.14
7	0.77	7	1.0	0.77
9	0.40	9	0.5	0.40
11	0.33	11	0.35	0.33
13	0.21	13	0.30	0.21
15<=n<=39	0.15x15/n	15<=n<=39	3.85/n	0.15x15/n
Even harmonics				
2	1.08			
4	0.43			
6	0.30			
8<=n<=40	0.23x8/n			

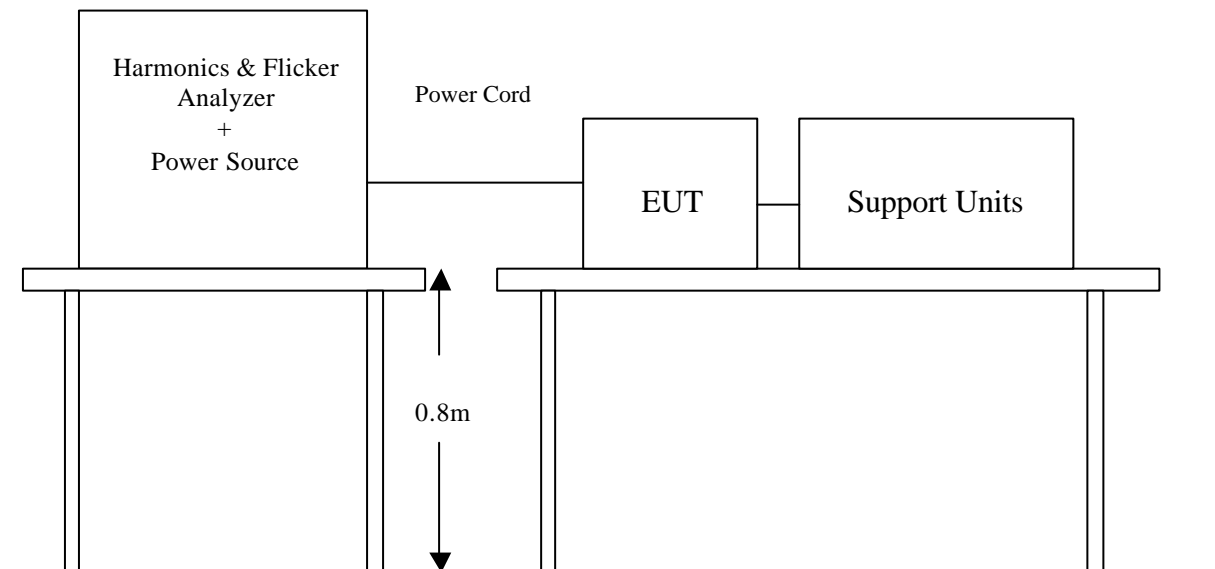

Block Diagram of Test Setup:

Test Procedure:

- a. The EUT was placed on the top of a wooden table 0.8 meters above the ground and operated to produce the maximum harmonic components under normal operating conditions for each successive harmonic component in turn.
- b. The correspondent test program of test instrument to measure the current harmonics emanated from EUT is chosen. The measure time shall be not less than the time necessary for the EUT to be exercised.

Test Result :

PASS **FAIL**

Note: According to clause 7 of EN 61000-3-2: 2000, equipment with a rated power of 75W or less, no limits apply. The test result is only for reference.

9 POWER VOLTAGE FLUCTUATION / FLICKER TEST

Port : AC Power Port
Basic Standard : EN 61000-3-3 (1995 + A1: 2001)
Limits : § of EN 61000-3-3
Tested by : SAM SU
Temperature : 19°C
Humidity : 55%

Limit:

TEST ITEM	LIMIT	REMARK
P_{st}	1.0	P_{st} means short-term flicker indicator.
P_{lt}	0.65	P_{lt} means long-term flicker indicator.
T_{dt} (ms)	500	T_{dt} means maximum time that dt exceeds 3 %.
d_{max} (%)	4%	d_{max} means maximum relative voltage change.
dc (%)	3.3%	dc means relative steady-state voltage change

Block Diagram of Test Setup:

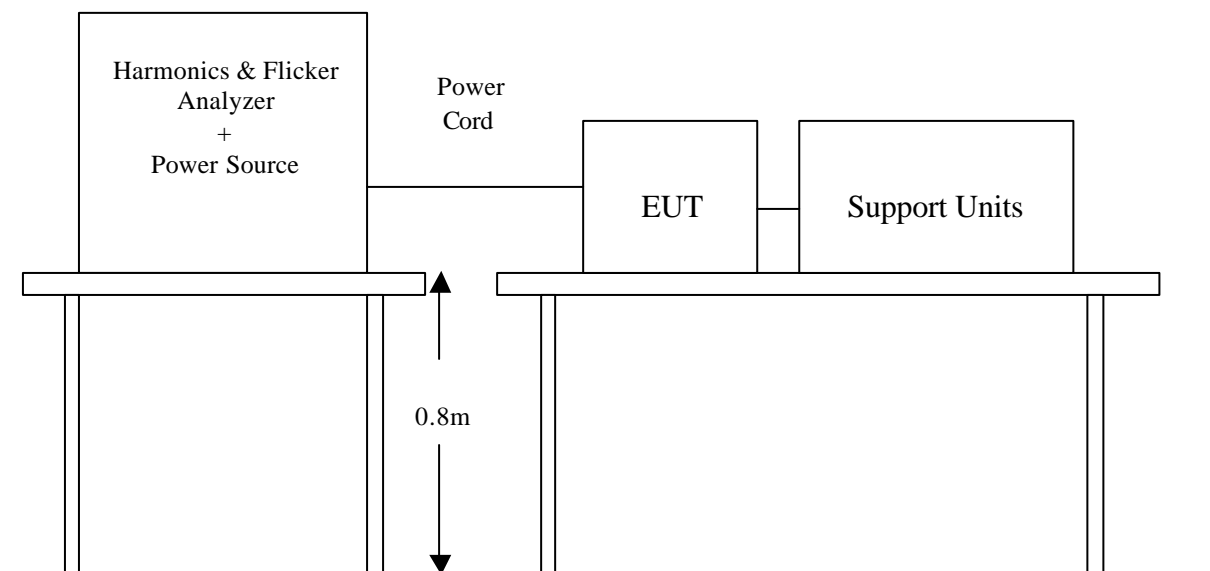



Test Procedure:

- a. The EUT was placed on the top of a wooden table 0.8 meters above the ground and operated to produce the most unfavorable sequence of voltage changes under normal operating conditions.
- b. During the flick measurement, the measure time shall include that part of whole operation cycle in which the EUT produce the most unfavorable sequence of voltage changes. The observation period for short-term flicker indicator is 10 minutes and the observation period for long-term flicker indicator is 2 hours.

Test Result: (See Appendix II for details)

Test Parameter	Measurement Value	Limit	Result
P_{st}	0.338	1.0	Pass
P_{lt}	0.202	0.65	Pass
T_{dt} (ms)	0	500	Pass
d_{max} (%)	0.54	4%	Pass
dc (%)	0.52	3.3%	Pass

Note: None.

10 ELECTROSTATIC DISCHARGE (ESD) IMMUNITY TEST

- Port** : Enclosure
- Basic Standard** : IEC/EN 61000-4-2
- Test Level** : $\pm 2, 4, 8$ kV (Air Discharge)
 $\pm 2, 4, 6$ kV (Contact Discharge)
- Performance Criterion** : The Equipment or System shall be able to provide the essential performance and remain safe.
- Tested by** : SAM SU
- Temperature** : 19°C
- Humidity** : 55% RH
- Pressure** : 1005mbar

Block Diagram of Test Setup:

(The 470 k Ω resistors are installed per standard requirement.)

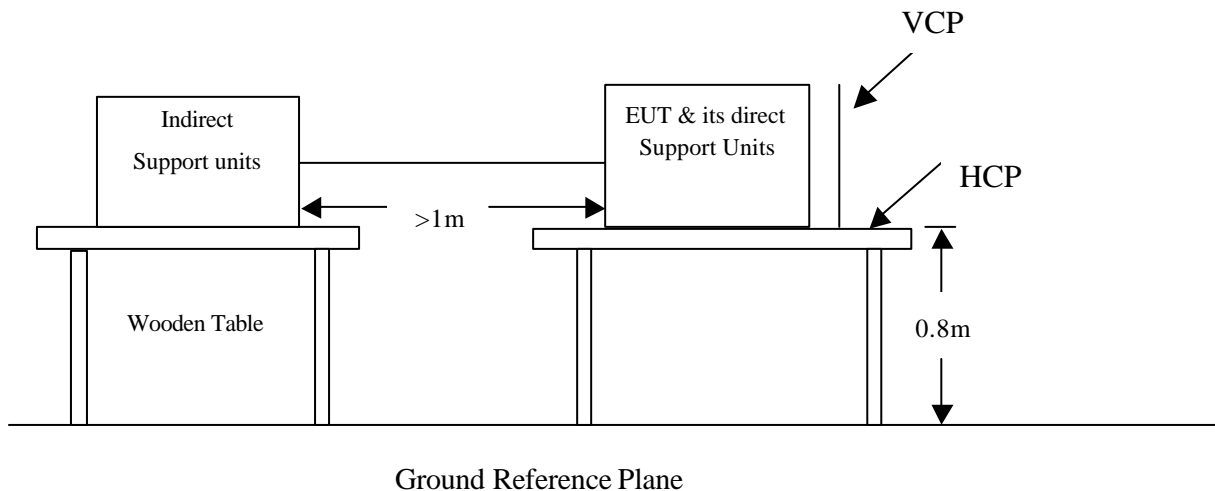



Test Procedure:

The electrostatic discharges were applied as follows:

Amount of Discharges	Voltage	Coupling	Result (Pass/Fail)
20 / Point	± 2, 4, 8 kV	Air Discharge	Pass
20 / Point	± 2, 4, 6 kV	Contact Discharge	Pass
20 / Point	± 2, 4, 6 kV	Indirect Discharge HCP	Pass
20 / Point	± 2, 4, 6 kV	Indirect Discharge VCP (Front)	Pass
20 / Point	± 2, 4, 6 kV	Indirect Discharge VCP (Left)	Pass
20 / Point	± 2, 4, 6 kV	Indirect Discharge VCP (Back)	Pass
20 / Point	± 2, 4, 6 kV	Indirect Discharge VCP (Right)	Pass

***For the tested points to EUT, please refer to attached page.
(Blue Arrow Mark For Contact Discharge And Red Arrow Mark For Air Discharge)*

Observation: No function degraded during the tests.

Compliance Criteria:

Under the test conditions specified in 36.202, the EQUIPMENT or SYSTEM shall be able to provide the ESSENTIAL PERFORMANCE and remain safe. The following DEGRADATIONS associated with ESSENTIAL PERFORMANCE and safety shall not be allowed:

- Component failures
- Changes in programmable parameters
- Reset to factory defaults (manufacturer' s presets)
- Chang of operating mode
- False alarms
- Cessation or interruption of any intended operation, even if accompanied by an alarm
- Initiation of any unintended operation, including unintended or uncontrolled motion, even if accompanied by an alarm
- Error of a displayed numerical value sufficiently large to affect diagnosis or treatment
- Noise on a waveform in which the noise is indistinguishable from physiologically-produced signals or the noise interferes with interpretation of physiologically-produced signals
- Artefact or distortion in an image in which the artefact is indistinguishable from physiologically-produced signals or the distortion interferes with interpretation of physiologically-produced signals
- Failure of automatic diagnosis or treatment EQUIPMENT and SYSTEMS to diagnose or treat, even if accompanied by an alarm.

For EQUIPMENT and SYSTEMS with multiple FUNCTIONS, the criteria apply to each FUNCTION, parameter and channel.

The EQUIPMENT or SYSTEM may exhibit DEGRADATION of performance (e.g. deviation from manufacturer' s specifications) that does not affect ESSENTIAL PERFORMANCE or safety.



The Tested Points of EUT

Photo 1 of 3

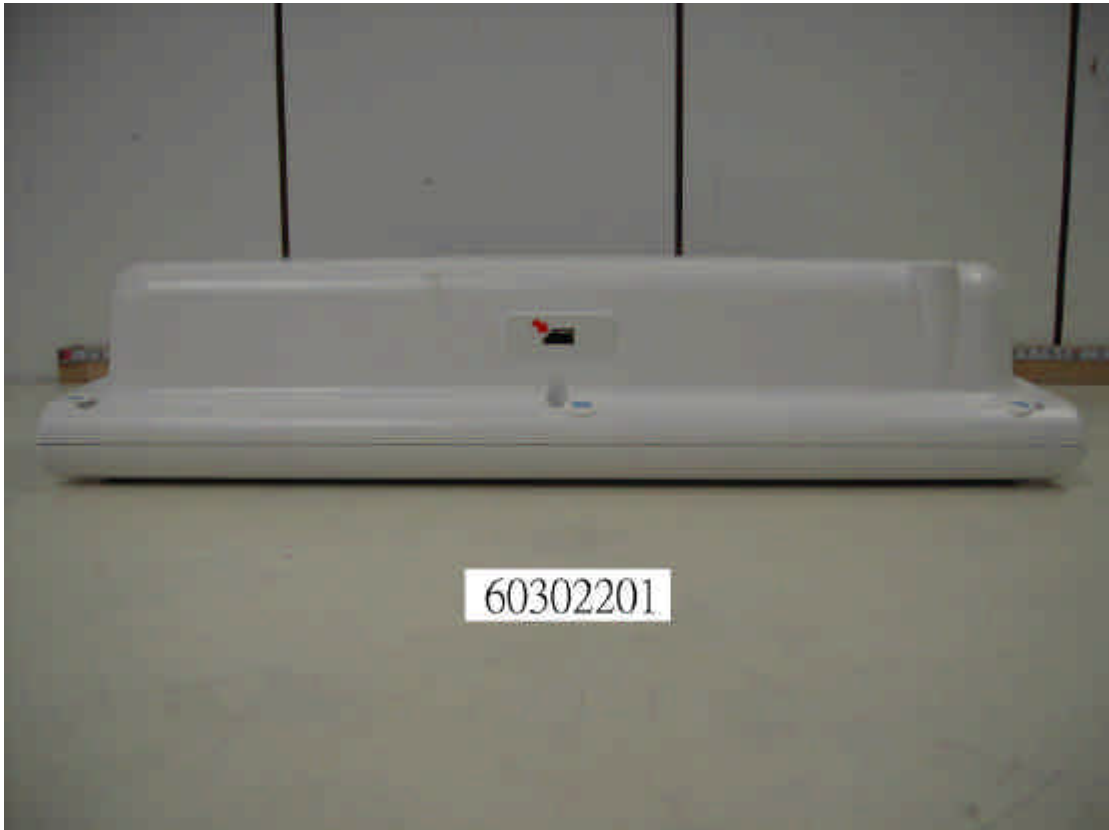

Photo 2 of 3





Photo 3 of 3



11 RADIATED ELECTROMAGNETIC FIELD IMMUNITY TEST

Port	: Enclosure
Basic Standard	: IEC/EN 61000-4-3
Requirements	: 3 V/m with 80% AM, 1kHz Modulation.
Performance Criterion	: The Equipment or System shall be able to provide the essential performance and remain safe.
Tested by	: SAM SU
Temperature	: 19°C
Humidity	: 55% RH
Pressure	: 1005mbar

Block Diagram of Test Setup:

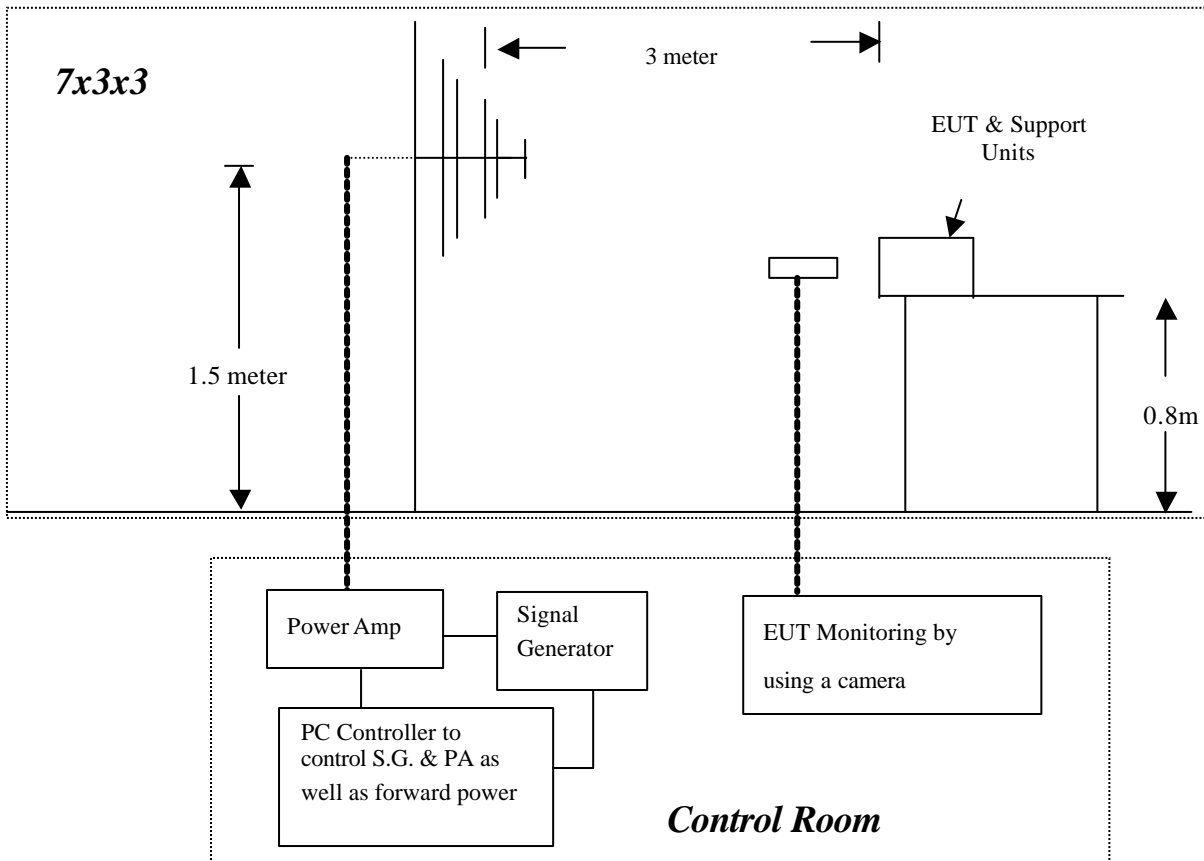



Test Procedure:

Frequency Range 80MHz ~ 2500MHz
Steps : 1 % of fundamental
Dwell Time : 3 sec

Range (MHz)	Field	Modulation	Polarity	Position	Result (Pass/Fail)
80-2500	3V/m	Yes	H	0	Pass
80-2500	3V/m	Yes	V	0	Pass
80-2500	3V/m	Yes	H	90	Pass
80-2500	3V/m	Yes	V	90	Pass
80-2500	3V/m	Yes	H	180	Pass
80-2500	3V/m	Yes	V	180	Pass
80-2500	3V/m	Yes	H	270	Pass
80-2500	3V/m	Yes	V	270	Pass

Observation: No function degraded during the tests.

Compliance Criteria:

Under the test conditions specified in 36.202, the EQUIPMENT or SYSTEM shall be able to provide the ESSENTIAL PERFORMANCE and remain safe. The following DEGRADATIONS associated with ESSENTIAL PERFORMANCE and safety shall not be allowed:

- Component failures
- Changes in programmable parameters
- Reset to factory defaults (manufacturer' s presets)
- Chang of operating mode
- False alarms
- Cessation or interruption of any intended operation, even if accompanied by an alarm
- Initiation of any unintended operation, including unintended or uncontrolled motion, even if accompanied by an alarm
- Error of a displayed numerical value sufficiently large to affect diagnosis or treatment
- Noise on a waveform in which the noise is indistinguishable from physiologically-produced signals or the noise interferes with interpretation of physiologically-produced signals
- Artefact or distortion in an image in which the artefact is indistinguishable from physiologically-produced signals or the distortion interferes with interpretation of physiologically-produced signals
- Failure of automatic diagnosis or treatment EQUIPMENT and SYSTEMS to diagnose or treat, even if accompanied by an alarm.

For EQUIPMENT and SYSTEMS with multiple FUNCTIONS, the criteria apply to each FUNCTION, parameter and channel.

The EQUIPMENT or SYSTEM may exhibit DEGRADATION of performance (e.g. deviation from manufacturer' s specifications) that does not affect ESSENTIAL PERFORMANCE or safety.

12 FAST TRANSIENTS/BURST IMMUNITY TEST

Port	: AC Power Port
Basic Standard	: IEC/EN 61000-4-4
Requirements	: ± 2 kV for AC Power Port
Performance Criterion	: The Equipment or System shall be able to provide the essential performance and remain safe.
Tested by	: SAM SU
Temperature	: 19°C
Humidity	: 55%
Pressure	: 1005mbar

Block Diagram of Test Setup:

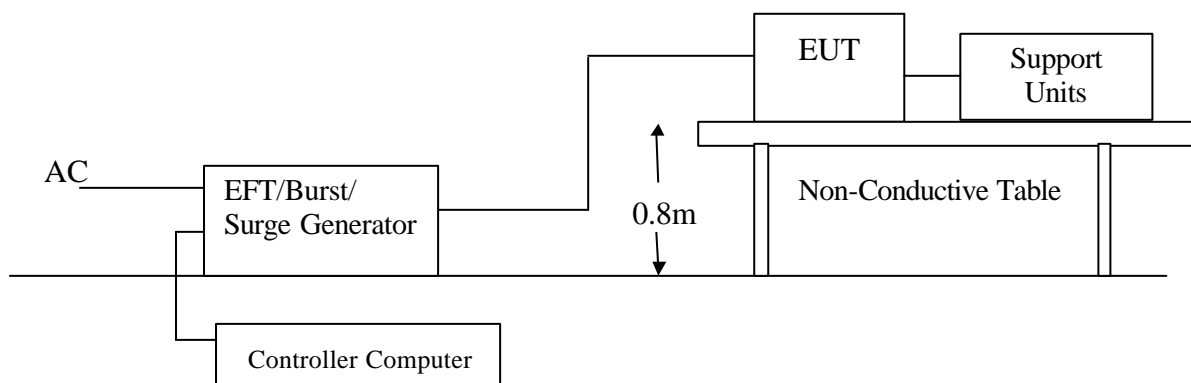



Test Procedure:

Impulse Frequency : 5kHz
Tr/Th : 5/50ns
Burst Duration : 15ms
Burst Period : 300ms

Inject Line	Voltage kV	Inject Method	Result (Pass/Fail)
L	± 2	Direct	Pass
N	± 2	Direct	Pass
PE	± 2	Direct	Pass
L + N	± 2	Direct	Pass
L + PE	± 2	Direct	Pass
N + PE	± 2	Direct	Pass
L + N + PE	± 2	Direct	Pass

Observation: No function degraded during the tests.

Compliance Criteria:

Under the test conditions specified in 36.202, the EQUIPMENT or SYSTEM shall be able to provide the ESSENTIAL PERFORMANCE and remain safe. The following DEGRADATIONS associated with ESSENTIAL PERFORMANCE and safety shall not be allowed:

- Component failures
- Changes in programmable parameters
- Reset to factory defaults (manufacturer' s presets)
- Chang of operating mode
- False alarms
- Cessation or interruption of any intended operation, even if accompanied by an alarm
- Initiation of any unintended operation, including unintended or uncontrolled motion, even if accompanied by an alarm
- Error of a displayed numerical value sufficiently large to affect diagnosis or treatment
- Noise on a waveform in which the noise is indistinguishable from physiologically-produced signals or the noise interferes with interpretation of physiologically-produced signals
- Artefact or distortion in an image in which the artefact is indistinguishable from physiologically-produced signals or the distortion interferes with interpretation of physiologically-produced signals
- Failure of automatic diagnosis or treatment EQUIPMENT and SYSTEMS to diagnose or treat, even if accompanied by an alarm.

For EQUIPMENT and SYSTEMS with multiple FUNCTIONS, the criteria apply to each FUNCTION, parameter and channel.

The EQUIPMENT or SYSTEM may exhibit DEGRADATION of performance (e.g. deviation from manufacturer' s specifications) that does not affect ESSENTIAL PERFORMANCE or safety.

13 SURGE IMMUNITY TEST

Port	: AC Power Port
Basic Standard	: IEC/EN 61000-4-5
Requirements	: ± 1 kV(Line to Line) for AC Power Port ± 2 kV (Line to Ground) for AC Power Port
Performance Criteria	: The Equipment or System shall be able to provide the essential performance and remain safe.
Tested by	: SAM SU
Temperature	: 19°C
Humidity	: 55%
Pressure	: 1005mbar

Block Diagram of Test Setup:

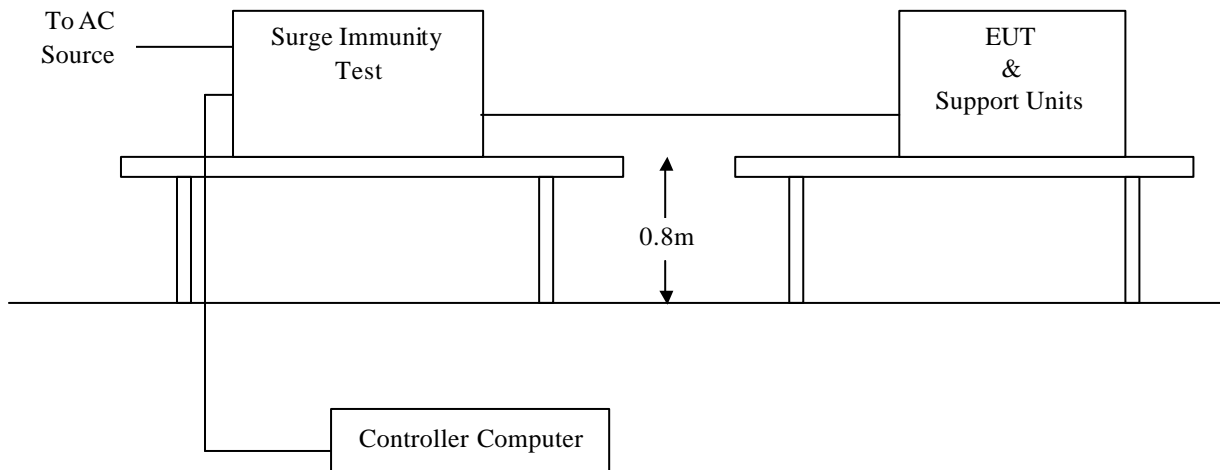

**Test Procedure:**

Voltage Waveform : 1.2/50 μ s
Current Waveform : 8/20 μ s
Polarity : Positive/Negative
Phase angle : 0°, 90°, 180°, 270°, 359°
Number of Test : 5

Coupling Line	Voltage (kV)	Polarity	Coupling Method	Result (Pass/Fail)
L1-L2	± 1	Positive	Capacitive	Pass
L1-PE	± 1 , ± 2	Positive	Capacitive	Pass
L2-PE	± 1 , ± 2	Positive	Capacitive	Pass
L1-L2	± 1	Negative	Capacitive	Pass
L1-PE	± 1 , ± 2	Negative	Capacitive	Pass
L2-PE	± 1 , ± 2	Negative	Capacitive	Pass

Observation: No function degraded during the tests.

Compliance Criteria:

Under the test conditions specified in 36.202, the EQUIPMENT or SYSTEM shall be able to provide the ESSENTIAL PERFORMANCE and remain safe. The following DEGRADATIONS associated with ESSENTIAL PERFORMANCE and safety shall not be allowed:

- Component failures
- Changes in programmable parameters
- Reset to factory defaults (manufacturer's presets)
- Change of operating mode
- False alarms
- Cessation or interruption of any intended operation, even if accompanied by an alarm
- Initiation of any unintended operation, including unintended or uncontrolled motion, even if accompanied by an alarm
- Error of a displayed numerical value sufficiently large to affect diagnosis or treatment
- Noise on a waveform in which the noise is indistinguishable from physiologically-produced signals or the noise interferes with interpretation of physiologically-produced signals
- Artefact or distortion in an image in which the artefact is indistinguishable from physiologically-produced signals or the distortion interferes with interpretation of physiologically-produced signals
- Failure of automatic diagnosis or treatment EQUIPMENT and SYSTEMS to diagnose or treat, even if accompanied by an alarm.

For EQUIPMENT and SYSTEMS with multiple FUNCTIONS, the criteria apply to each FUNCTION, parameter and channel.

The EQUIPMENT or SYSTEM may exhibit DEGRADATION of performance (e.g. deviation from manufacturer's specifications) that does not affect ESSENTIAL PERFORMANCE or safety.

14 CONDUCTED DISTURBANCE/INDUCED RADIO-FREQUENCY FIELD IMMUNITY TEST

Port	: AC Power Port
Basic Standard	: IEC/EN 61000-4-6
Requirements	: 3 V with 80% AM, 1kHz Modulation.
Injection Method	: CDN-M3 for AC Power Port
Performance Criterion	: The Equipment or System shall be able to provide the essential performance and remain safe.
Tested by	: SAM SU
Temperature	: 19°C
Humidity	: 55%
Pressure	: 1005mbar

Block Diagram of Test Setup:

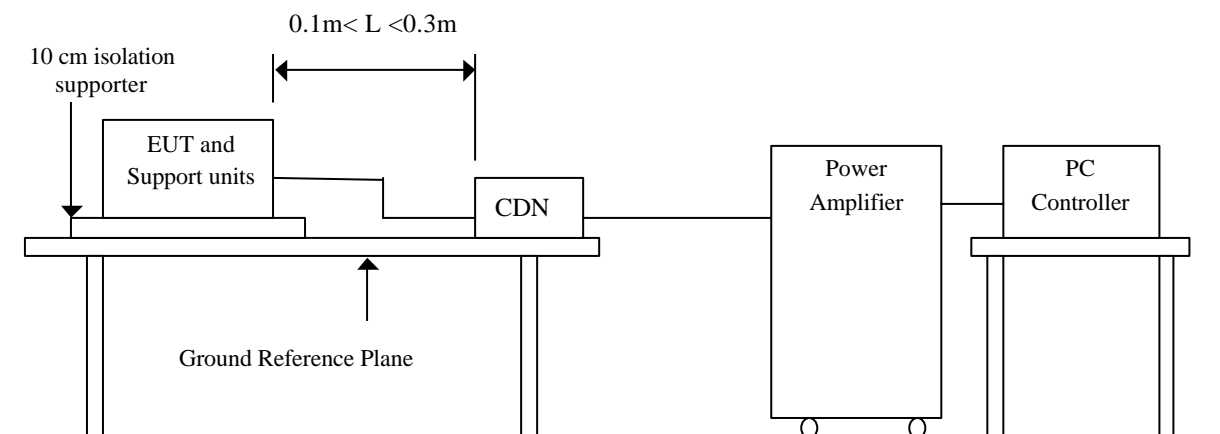



Test Procedure:

Frequency Range : 0.15MHz-80MHz
Frequency Step : 1% of fundamental
Dwell Time : 3 sec

Range (MHz)	Field	Modulation	Result (Pass/Fail)
0.15-80	3V	Yes	Pass

Observation: No function degraded during the tests.

Compliance Criteria:

Under the test conditions specified in 36.202, the EQUIPMENT or SYSTEM shall be able to provide the ESSENTIAL PERFORMANCE and remain safe. The following DEGRADATIONS associated with ESSENTIAL PERFORMANCE and safety shall not be allowed:

- Component failures
- Changes in programmable parameters
- Reset to factory defaults (manufacturer' s presets)
- Chang of operating mode
- False alarms
- Cessation or interruption of any intended operation, even if accompanied by an alarm
- Initiation of any unintended operation, including unintended or uncontrolled motion, even if accompanied by an alarm
- Error of a displayed numerical value sufficiently large to affect diagnosis or treatment
- Noise on a waveform in which the noise is indistinguishable from physiologically-produced signals or the noise interferes with interpretation of physiologically-produced signals
- Artefact or distortion in an image in which the artefact is indistinguishable from physiologically-produced signals or the distortion interferes with interpretation of physiologically-produced signals
- Failure of automatic diagnosis or treatment EQUIPMENT and SYSTEMS to diagnose or treat, even if accompanied by an alarm.

For EQUIPMENT and SYSTEMS with multiple FUNCTIONS, the criteria apply to each FUNCTION, parameter and channel.

The EQUIPMENT or SYSTEM may exhibit DEGRADATION of performance (e.g. deviation from manufacturer' s specifications) that does not affect ESSENTIAL PERFORMANCE or safety.

15 POWER FREQUENCY MAGNETIC FIELD IMMUNITY TEST

Port	: Enclosure
Basic Standard	: IEC/EN 61000-4-8
Requirements	: 3 A/m, 50/60Hz
Performance Criterion	: The Equipment or System shall be able to provide the essential performance and remain safe.
Tested by	: SAM SU
Temperature	: 19°C
Humidity	: 55% RH
Pressure	: 1005mbar

Block Diagram of Test Setup:

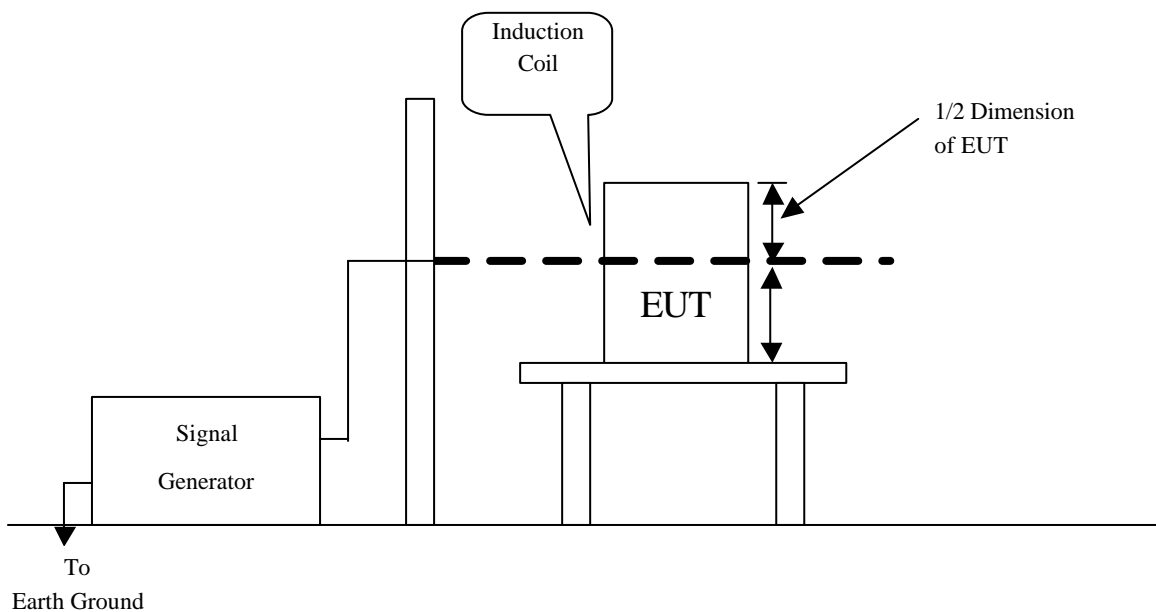



Test Procedure:

Field Strength : 3A/m
Power Freq. : 50Hz, 60Hz
Orientation : X, Y, Z

Orientation	Field	Result	Remark
X	3A/m, 50Hz	Pass	No any function degraded during the tests.
Y	3A/m, 50Hz	Pass	No any function degraded during the tests.
Z	3A/m, 50Hz	Pass	No any function degraded during the tests.
X	3A/m, 60Hz	Pass	No any function degraded during the tests.
Y	3A/m, 60Hz	Pass	No any function degraded during the tests.
Z	3A/m, 60Hz	Pass	No any function degraded during the tests.

Observation: No function degraded during the tests.

Compliance Criteria:

Under the test conditions specified in 36.202, the EQUIPMENT or SYSTEM shall be able to provide the ESSENTIAL PERFORMANCE and remain safe. The following DEGRADATIONS associated with ESSENTIAL PERFORMANCE and safety shall not be allowed:

- Component failures
- Changes in programmable parameters
- Reset to factory defaults (manufacturer' s presets)
- Chang of operating mode
- False alarms
- Cessation or interruption of any intended operation, even if accompanied by an alarm
- Initiation of any unintended operation, including unintended or uncontrolled motion, even if accompanied by an alarm
- Error of a displayed numerical value sufficiently large to affect diagnosis or treatment
- Noise on a waveform in which the noise is indistinguishable from physiologically-produced signals or the noise interferes with interpretation of physiologically-produced signals
- Artefact or distortion in an image in which the artefact is indistinguishable from physiologically-produced signals or the distortion interferes with interpretation of physiologically-produced signals
- Failure of automatic diagnosis or treatment EQUIPMENT and SYSTEMS to diagnose or treat, even if accompanied by an alarm.

For EQUIPMENT and SYSTEMS with multiple FUNCTIONS, the criteria apply to each FUNCTION, parameter and channel.

The EQUIPMENT or SYSTEM may exhibit DEGRADATION of performance (e.g. deviation from manufacturer' s specifications) that does not affect ESSENTIAL PERFORMANCE or safety.

16 VOLTAGE DIPS / SHORT INTERRUPTIONS

Port : AC Power Port

Basic Standard : IEC/EN 61000-4-11

Requirement : PHASE ANGLE 0°, 180°

Voltage Dips	Test Level % U _T	Reduction (%)	Duration (periods)
	<5	>95	0.5
	40	60	5
	70	30	25

Voltage Interruptions	Test Level % U _T	Reduction (%)	Duration (second)
	<5	>95	5

Test Interval : Min. 10 sec.

Performance Criteria : The Equipment or System shall be able to provide the essential performance and remain safe.

Tested by : SAM SU

Temperature : 19°C

Humidity : 55%

Pressure : 1005mbar

Block Diagram of Test Setup:

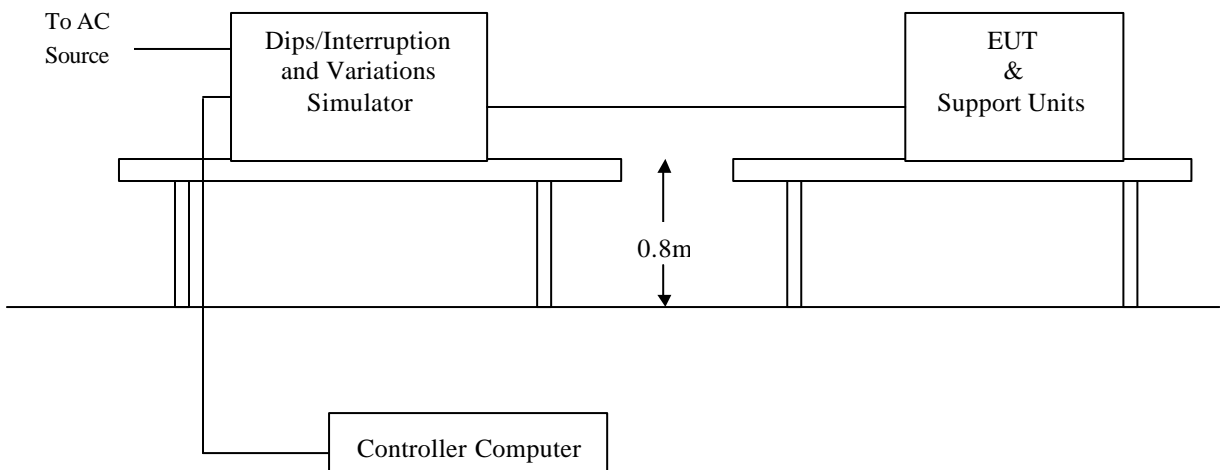



Test Procedure:

The duration with a sequence of three dips/interruptions with interval of 10 s minimums (Between each test event)

Voltage Dips:

Test Level % U _T	Reduction (%)	Duration (periods)	Observation	Result
0	100	0.5	Normal	A
40	60	5	Normal	A
70	30	25	Normal	A

Voltage Interruptions:

Test Level % U _T	Reduction (%)	Duration (second)	Observation	Result
0	100	5	EUT shut down, but EUT can be auto recovered after power turn on.	C

Note:

1. Normal - No any functions degrade during and after the test.
2. For Voltage Interruption, EQUIPMENT and SYSTEMS are allowed a deviation from the requirements of 36.202.1) at the IMMUNITY TEST LEVEL specified in Table 211, provided the EQUIPMENT or SYSTEM remains safe, experiences no component failures and is restorable to the pre-test state with OPERATOR intervention. Determination of compliance is based upon performance of the EQUIPMENT or SYSTEM during and after application of the test sequence.

Observation: No function degraded during the tests.



Compliance Criteria:

Under the test conditions specified in 36.202, the EQUIPMENT or SYSTEM shall be able to provide the ESSENTIAL PERFORMANCE and remain safe. The following DEGRADATIONS associated with ESSENTIAL PERFORMANCE and safety shall not be allowed:

- Component failures
- Changes in programmable parameters
- Reset to factory defaults (manufacturer' s presets)
- Chang of operating mode
- False alarms
- Cessation or interruption of any intended operation, even if accompanied by an alarm
- Initiation of any unintended operation, including unintended or uncontrolled motion, even if accompanied by an alarm
- Error of a displayed numerical value sufficiently large to affect diagnosis or treatment
- Noise on a waveform in which the noise is indistinguishable from physiologically-produced signals or the noise interferes with interpretation of physiologically-produced signals
- Artefact or distortion in an image in which the artefact is indistinguishable from physiologically-produced signals or the distortion interferes with interpretation of physiologically-produced signals
- Failure of automatic diagnosis or treatment EQUIPMENT and SYSTEMS to diagnose or treat, even if accompanied by an alarm.

For EQUIPMENT and SYSTEMS with multiple FUNCTIONS, the criteria apply to each FUNCTION, parameter and channel.

The EQUIPMENT or SYSTEM may exhibit DEGRADATION of performance (e.g. deviation from manufacturer' s specifications) that does not affect ESSENTIAL PERFORMANCE or safety.



APPENDIX I - PHOTOGRAPHS OF TEST SETUP

LINE CONDUCTED EMISSION TEST (EN 55011)



RADIATED EMISSION TEST (EN 55011)

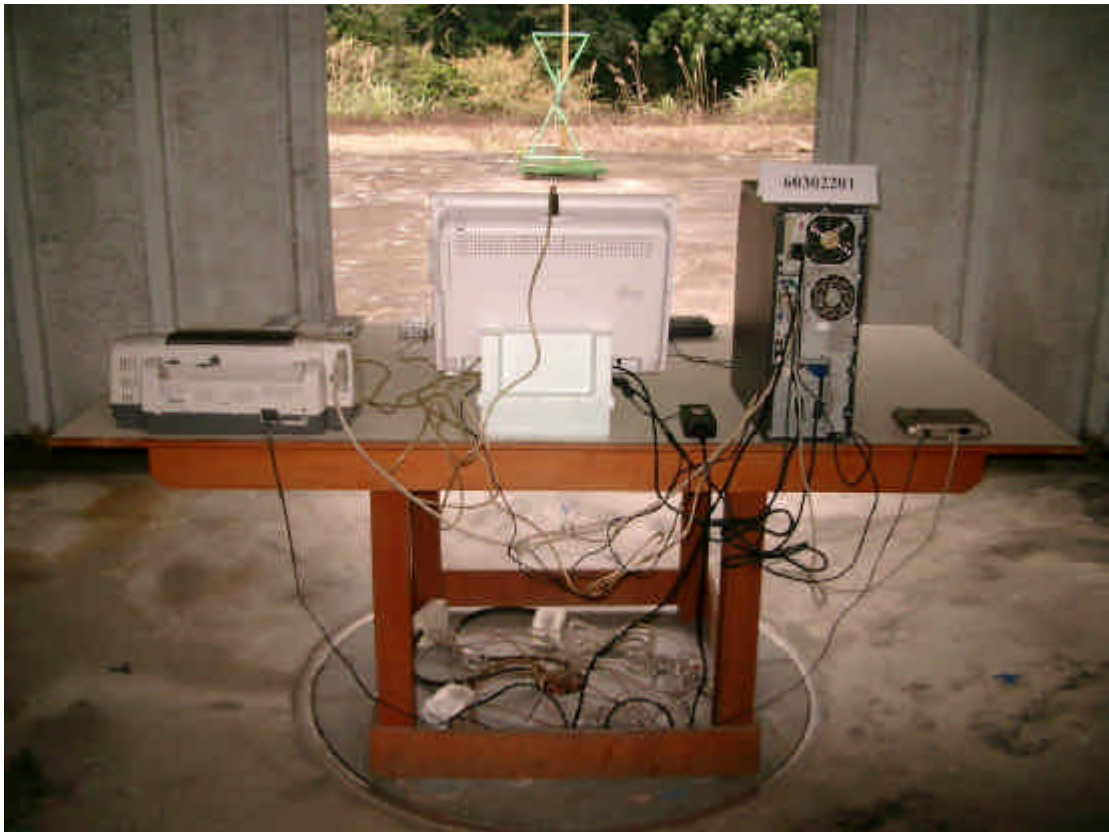

POWER HARMONIC & VOLTAGE FLUCTUATION / FLICKER TEST



ELECTROSTATIC DISCHARGE TEST



RADIATED ELECTROMAGNETIC FIELD TEST



FAST TRANSIENTS/BURST TEST



SURGE IMMUNITY TEST



CONDUCTED DISTURBANCE, INDUCED BY RADIO-FREQUENCY FIELDS TEST



POWER FREQUENCY MAGNETIC FIELD IMMUNITY TEST





VOLTAGE DIPS / INTERRUPTION TEST





APPENDIX II – TEST RESULT OF EN 61000-3-3

Test Result: Pass

Status: Test Completed

Pst_i and limit line

European Limits

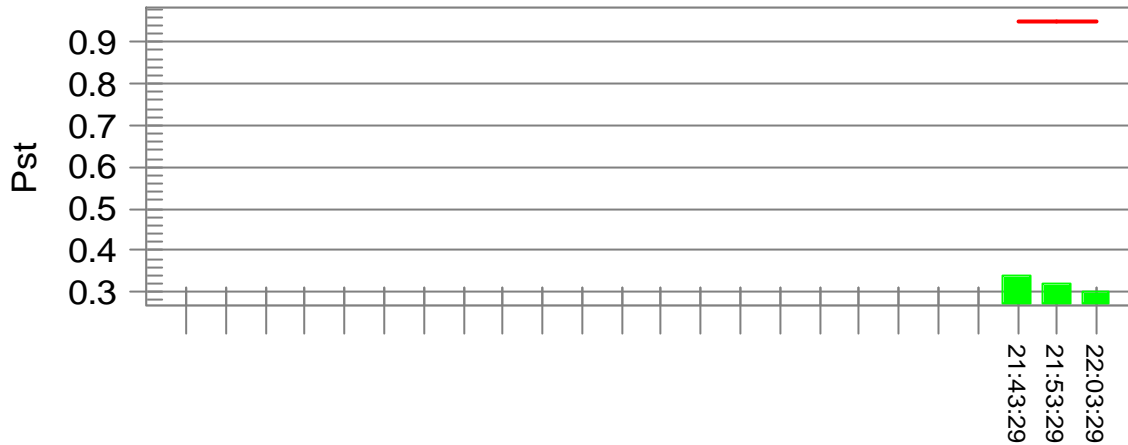

Time is too short for Plt plot

Parameter values recorded during the test:

Vrms at the end of test (Volt):	229.21			
Highest dt (%):	0.22	Test limit (%):	3.14	Pass
Time(mS) > dt:	0.0	Test limit (mS):	500.0	Pass
Highest dc (%):	0.52	Test limit (%):	3.14	Pass
Highest dmax (%):	0.54	Test limit (%):	3.80	Pass
Highest Pst (10 min. period):	0.338	Test limit:	0.950	Pass
Highest Plt (2 hr. period):	0.202	Test limit:	0.617	Pass