



## CE EMC

### TEST REPORT

For

**Intel Pentium4 PCI Half-Size SBC**

**Model: HSB-835P A0.1**

**Trade Name: AAEON**

Issued to

**AAEON Technology Inc.**

**5F, No.135, Lane 235, Pao Chiao Rd., Hsin-Tien City,  
Taipei, Taiwan, R.O.C.**

Issued by



**Compliance Certification Services Inc.  
Hsintien Lab.**

**No. 165, Chungsen Road, Hsintien City  
Taipei Hsien, Taiwan**

**TEL: (02) 2217-0894**

**FAX: (02) 2217-1029**



---

**Note:** This report shall not be reproduced except in full, without the written approval of Compliance Certification Services Inc. Ltd. This document may be altered or revised by Compliance Certification Services Inc. personnel only, and shall be noted in the revision section of the document.



## TABLE OF CONTENTS

<b>1</b>	<b>TEST RESULT CERTIFICATION .....</b>	<b>3</b>
<b>2</b>	<b>EUT DESCRIPTION .....</b>	<b>4</b>
<b>3</b>	<b>TEST METHODOLOGY.....</b>	<b>5</b>
<b>3.1</b>	<b>EUT SYSTEM OPERATION.....</b>	<b>5</b>
<b>3.2</b>	<b>DECISION OF FINAL TEST MODE .....</b>	<b>5</b>
<b>4</b>	<b>SETUP OF EQUIPMENT UNDER TEST.....</b>	<b>6</b>
<b>5</b>	<b>FACILITIES AND ACCREDITATIONS.....</b>	<b>7</b>
<b>5.1</b>	<b>FACILITIES .....</b>	<b>7</b>
<b>5.2</b>	<b>LABORATORY ACCREDITATIONS AND LISTINGS .....</b>	<b>7</b>
<b>6</b>	<b>INSTRUMENT AND CALIBRATION .....</b>	<b>8</b>
<b>6.1</b>	<b>MEASURING INSTRUMENT CALIBRATION .....</b>	<b>8</b>
<b>6.2</b>	<b>TEST AND MEASUREMENT EQUIPMENT.....</b>	<b>8</b>
<b>7</b>	<b>LINE CONDUCTED &amp; RADIATED EMISSION TEST.....</b>	<b>11</b>
<b>7.1</b>	<b>LIMIT .....</b>	<b>11</b>
<b>7.2</b>	<b>TEST PROCEDURE OF LINE CONDUCTED EMISSION.....</b>	<b>12</b>
<b>7.3</b>	<b>TEST PROCEDURE OF COMMON MODE CONDUCTED EMISSION FOR TELECOMMUNICATION PORT .....</b>	<b>13</b>
<b>7.4</b>	<b>TEST PROCEDURE OF RADIATED EMISSION .....</b>	<b>14</b>
<b>7.5</b>	<b>TEST RESULTS .....</b>	<b>16</b>
<b>8</b>	<b>POWER HARMONICS TEST .....</b>	<b>18</b>
<b>9</b>	<b>POWER VOLTAGE FLUCTUATION / FLICKER TEST .....</b>	<b>20</b>
<b>10</b>	<b>ELECTROSTATIC DISCHARGE (ESD) IMMUNITY TEST.....</b>	<b>22</b>
<b>11</b>	<b>RADIATED ELECTROMAGNETIC FIELD IMMUNITY TEST .....</b>	<b>25</b>
<b>12</b>	<b>FAST TRANSIENTS/BURST IMMUNITY TEST.....</b>	<b>28</b>
<b>13</b>	<b>SURGE IMMUNITY TEST .....</b>	<b>30</b>
<b>14</b>	<b>CONDUCTED DISTURBANCE/INDUCED RADIO-FREQUENCY FIELD IMMUNITY TEST.....</b>	<b>32</b>
<b>15</b>	<b>POWER FREQUENCY MAGNETIC FIELD IMMUNITY TEST.....</b>	<b>34</b>
<b>16</b>	<b>VOLTAGE DIPS / SHORT INTERRUPTIONS.....</b>	<b>36</b>
	<b>APPENDIX I - PHOTOGRAPHS OF TEST SETUP.....</b>	<b>38</b>
	<b>APPENDIX II – TEST RESULT OF EN 61000-3-3 .....</b>	<b>46</b>
	<b>APPENDIX III - TEST RESULT OF FINAL DATAS.....</b>	<b>50</b>



# 1 TEST RESULT CERTIFICATION

**Applicant:** AAEON Technology Inc.  
5F, No.135, Lane 235, Pao Chiao Rd., Hsin-Tien City,  
Taipei, Taiwan, R.O.C.

**Manufacturer:** AAEON Technology Inc.  
5F, No.135, Lane 235, Pao Chiao Rd., Hsin-Tien City,  
Taipei, Taiwan, R.O.C.

**Equipment Under Test:** Intel Pentium4 PCI Half-Size SBC

**Trade Name:** AAEON

**Model:** HSB-835P A0.1

**Detailed EUT Description:** See Item 2 of this report

**Date of Test:** January 26, 2005

Applicable Standard	Class/Limit/Criterion	Test Result
EN 55022:1998 + A1: 2000 + A2: 2003	Class A	No non-compliance noted
EN 61000-3-2: 2000	Class D	No non-compliance noted
EN 61000-3-3: 1995 + A1: 2001	Limit	No non-compliance noted
<b>EN 55024:1998 + A1: 2001 + A2: 2003, including</b>		
IEC 61000-4-2: 1995 +A1: 1998 +A2: 2000	Criterion B	No non-compliance noted
IEC 61000-4-3: 1995 +A1: 1998 +A2: 2000	Criterion A	No non-compliance noted
IEC 61000-4-4: 1995 +A1: 2000	Criterion B	No non-compliance noted
IEC 61000-4-5: 1995 +A1: 2000	Criterion B	No non-compliance noted
IEC 61000-4-6: 1996 +A1: 2000	Criterion A	No non-compliance noted
IEC 61000-4-8: 1993 +A1: 2000	Criterion A	N/A
IEC 61000-4-11: 1994 +A1: 2000	Criterion B/C/C	No non-compliance noted
Deviation from Applicable Standard		
None		

The above equipment was tested by Compliance Certification Services Inc. for compliance with the requirements set forth in the EMC Directive 89/336/EMC and the technical standards mentioned above. The results of testing in this report apply only to the product/system, which was tested. Other similar equipment will not necessarily produce the same results due to production tolerance and measurement uncertainties.

**Approved by:**

**Reviewed by:**

*Rick Yeo*

*Vince Chiang*

\_\_\_\_\_  
Rick Yeo  
Manager of Hsintien Laboratory  
Compliance Certification Services Inc.

\_\_\_\_\_  
Vince Chiang  
Section Manager of Hsintien Laboratory  
Compliance Certification Services Inc.



## 2 EUT DESCRIPTION

<b>Product</b>	Intel Pentium4 PCI Half-Size SBC
<b>Trade Name</b>	AAEON
<b>Model</b>	HSB-835P A0.1
<b>Housing Type</b>	Metal case
<b>Power Adaptor Power Rating</b>	110VAC~230VAC
<b>AC Power During Test</b>	230VAC / 50 Hz
<b>Power Supply Manufacturer</b>	Seventeam
<b>Power Supply Model Number</b>	ST-300HLP
<b>AC Power Cord Type</b>	Unshielded, 1.8m (Detachable)
<b>OSC/Clock Frequencies</b>	32.768kHz; 12MHz; 14.318MHz; 25MHz; 33MHz; 48MHz; 66MHz; 100MHz; 133MHz

### I/O PORT OF EUT

I/O PORT TYPE	Q' TY	TESTED WITH
1). PIO Port	1	1
2). SIO Port	2	2
3). PS/2 Keyboard Port	1	1
4). PS/2 Mouse Port	1	1
5). PS/2 one to two adaptor	1	1
6). VIDEO-OUT Port (VGA)	1	1
7). Earphone Port	1	1
8). LAN Port	1	1
9). USB 2.0 Port	3	3

*Note: Client consigns only one model sample (Model Number is HSB-835P A0.1) to test.*



### 3 TEST METHODOLOGY

#### 3.1 EUT SYSTEM OPERATION

1. Windows XP boots system.
2. Run Emctest.exe to activate all peripherals and display “H” pattern on monitor screen.
3. Run Winemc.exe and choose “E:/ & F:/ & G:/” to test USB 2.0 HDD.
4. Run Windows media player to play music.
5. Press the start menu, select executive and type ping 192.168.0.10 –t(EUT), ping 192.168.0.1 –t(Server PC).

*Note: Test program is self-repeating throughout the test.*

#### 3.2 DECISION OF FINAL TEST MODE

1. The following test mode(s) were scanned during the preliminary test:

**Mode:**

1. **Normal Mode**

2. After the preliminary scan, the following test mode(s) was found to produce the highest emission level.

**Conduction:** Mode 1

**Radiation:** Mode 1

Then, the EUT configuration and cable configuration of the above highest emission mode was chosen for all final test items.



## 4 SETUP OF EQUIPMENT UNDER TEST

### Setup Diagram

See test photographs attached in Appendix I for the actual connections between EUT and support equipment.

### Support Equipment

#### EUT Devices:

No	Equipment	Model #	Serial #	FCC/BSMI ID	Trade Name
1	Backplane	BP-2085P-P7 A1.0	N/A	N/A	AAEON
2	CPU (3.2GHz)	Pentium4	N/A	N/A	INTEL
3	RAM (512MB)	DDR400 DIMM3-3-3	N/A	N/A	SAMSUNG
4	HDD (30GB)	Fireball 3 ATA/133	N/A	BSMI: D33029	Maxtor
5	CD-ROM	CD-2052E	N/A	BSMI ID: 3902A934 DOC	AFREEY
6	FLOPPY DISK	FD-235HF	3010687	BSMI ID: 3902A889	TEAC
7	POWER	ST-300HLP	N/A	BSMI ID: 3912A045 DOC	Seventeam
8	Mother Board	HSB-835P A0.1	N/A	N/A	AAEON

#### Peripherals Devices:

No	Equipment	Model	Serial No.	FCC/BSMI ID	Trade Name	Data Cable	Power Cord
1	PS/2 Mouse	M-S34	LNA12301890	BSMI ID: 4862A011 DZL211029	Logitech	Shielded, 1.8m	N/A
2	PS/2 Mouse	M-S34	LNA12301890	BSMI ID: 4862A011 DZL211029	Logitech	Shielded, 1.8m	N/A
3	PS/2 Mouse	M071KC	443029438	DOC BSMI: R41108	DELL	Shielded, 1.8m	N/A
4	PS/2 Keyboard	SK-8110	N/A	DOC BSMI: T3A002	DELL	Shielded, 1.8m	N/A
5	Earphone	MSB301	N/A	N/A	e-Sense	Unshielded, 2.0m	N/A
6	USB 2.0 HDD	F12-U	N/A	BSMI ID: 4912A002	TeraSys	Shielded, 1.8m	N/A
7	USB 2.0 HDD	F12-U	N/A	BSMI ID: 4912A002	TeraSys	Shielded, 1.8m	N/A
8	USB 2.0 HDD	ME-911	N/A	BSMI: D33031	PORTABLE	Shielded, 1.8m	N/A
9	Printer	C20SX	N/A	BSMI ID: 3902E004	EPSON	Shielded, 1.8m	Unshielded, 1.8m
10	Monitor	202P40	BZ000405640110	FCC ID: A3KM107 BSMI: R33048	PHILIPS	Shielded, 1.8m with two cores	Unshielded, 1.8m
11	Modem	5JEG4033MKO	N/A	5RJT AI-35500-M5-E	TOP-SOLUTION	Shielded, 1.8m	Unshielded, 1.8m
12	Modem	5JEG4033MKO	N/A	5RJTAI-35500-M5-E	TOP-SOLUTION	Shielded, 1.8m	Unshielded, 1.8m
13	Server PC	P Evo D510C	7308-KN8Z-0010	BSMI ID: 3912Q007	COMPAQ	Unshielded, 20m	Unshielded, 1.8m with a core

*Note: All the above equipment/cables were placed in worse case positions to maximize emission signals during emission test. Grounding: Grounding was in accordance with the manufacturer's requirements and conditions for the intended use.*

## 5 FACILITIES AND ACCREDITATIONS







### 5.1 FACILITIES

All measurement facilities used to collect the measurement data are located at CCS Taiwan Hsintien Lab at No. 165, Chungshen Road, Hsintien City, Taipei Hsien, Taiwan.

The measurement facilities are constructed in conformance with the requirements of CISPR 16-1, ANSI C63.4 and other equivalent standards.

### 5.2 LABORATORY ACCREDITATIONS AND LISTINGS

The test facilities used to perform Electromagnetic compatibility tests are registered or accredited by the organizations listed in the following table which includes the recognized scope specifically.

Country	Agency	Scope of Accreditation	Logo
USA	A2LA	CFR 47, FCC Part 15/18 using ANSI 63.4; AS/NZS 3548; VCCI V3; CNS 13438; CNS 13439; CNS 13783; CNS 14115; CISPR 11/EN 55011; CISPR 14-1/EN 55014-1; CISPR 15/EN 55015; CISPR 22/EN 55022; EN 50081-1/EN 61000-6-3; EN 50082-1/EN 61000-6-4; IEC/EN 61000-4-2, IEC/EN 61000-4-3, IEC/EN 61000-4-4, IEC/EN 61000-4-5, IEC/EN 61000-4-6, IEC/EN 61000-4-8, IEC/EN 61000-4-11, IEC/EN 61000-3-2, IEC/EN 61000-3-3; CISPR 24/EN 55024; CISPR 14-2/EN 55014-2; EN 50081-2/EN 61000-6-1; EN 50082-2/EN 61000-6-2.	 824.01
USA	FCC	3/10 meter Open Area Test Sites to perform FCC Part 15/18 measurements	 250366
Japan	VCCI	3/10 meter Open Area Test Sites and Line Conducted Test Room to perform conducted/radiated measurements	 R-1434/1630~4 C-1511/1882
Norway	NEMKO	EN 50081-1/2, EN 50082-1/2, IEC 61000-6-1/2/3/4, EN 50091-2, EN 50130-4, EN 55011, EN 55013, EN 55014-1/2, EN 55015, EN 55022, EN 55024, EN 61000-3-2/3, EN 61326-1, IEC 61000-4-2/3/4/5/6/8/11, Cisp16-1/2/3/4	 ELA 103
Taiwan	CNLA	47 CFR FCC Part 15 Subpart B, EN 61000-3-2, EN 61000-3-3, CNS 13439, CNS 13783-1, CNS 13438, AS/NZS 3548, VCCI, CNS 13022-1/2/3, EN 55022, EN 55013, EN 55014-1, EN 61000-4-2/3/4/5/6/8/11, ENV 50204, ENV 50141, ENV 50142	 1108 ILAC MRA
Taiwan	BSMI	CNS 13438, CNS 13783-1, CNS 13439	 SL2-IN-E-0005 SL2-A1-E-0005 SL2-R1-E-0005 SL2-R2-E-0005

*Note: No part of this report may be used to claim or imply product endorsement by CNLA, A2LA or other government agency.*



## 6 INSTRUMENT AND CALIBRATION

### 6.1 MEASURING INSTRUMENT CALIBRATION

The measuring equipment utilized to perform the tests documented in this report has been calibrated once a year or in accordance with the manufacturer's recommendations, and is traceable to recognized national standards.

### 6.2 TEST AND MEASUREMENT EQUIPMENT

The following list contains measurement equipment used for testing. The equipment conforms to the requirement of CISPR 16-1, ANSI C63.2 and other required standards.

Calibration of all test and measurement, including any accessories that may effect such calibration, is checked frequently to ensure the accuracy. Adjustments are made and correction factors are applied in accordance with the instructions contained in the respective manual.

#### Equipment Used for Emission Measurement

Open Area Test Site # J				
EQUIPMENT	MFR	MODEL	SERIAL NUMBER	CAL. DUE
SITE NSA	CCS	J Site	N/A	09/18/2005
MEASURE RECEIVER	SCHAFFNER	SCR3501	330	06/27/2005
SPECTRUM ANALYZER	ADVANTEST	R3132	120900003	No Calibration Required
ANTENNA	SCHAFFNER	CBL 6112B	2800	09/25/2005
PRE-AMPLIFIER	SCHAFFNER	CPA9231A	3629	10/08/2005
CABLE	BELDEN	9913	N-TYPE #J1	10/08/2005
ATTENUATOR	MCL	UNAT-6	AT06-8	12/03/2005
THERMO-HYGRO METER	TFA	N/A	NO.3	11/09/2005
DECOUPLING NETWORK	FCC	F-201-DCN-5-6MM	22, 24	09/07/2005

*Note: The measurement uncertainty is less than +/- 3.36dB, which is evaluated as per the NAMAS NIS 81 and CISPR/A/291/CDV.*

Conducted Emission Test Site # A				
EQUIPMENT	MFR	MODEL	SERIAL NUMBER	CAL. DUE
TEST RECEIVER	R&S	ESHS20	840455/006	03/07/2005
LISN (EUT)	SCHWARZBECK	NSLK 8127	8127382	01/03/2006
LISN	SOLAR	8012-50-R-24-BNC	8305114	01/03/2006
BNC CABLE	MIYAZAKI	5D-FB	BNC A1	01/30/2005
THERMO-HYGRO METER	TOP	HA-202	9303-1	03/24/2005
4-Wire ISN	R&S	ENY41	100006	07/01/2005
2-Wire ISN	R&S	ENY22	100020	07/01/2005

*Note: The measurement uncertainty is less than +/- 2.83dB, which is evaluated as per the NAMAS NIS 81 and CISPR/A/291/CDV.*





<b>Power Harmonic &amp; Voltage Fluctuation/Flicker Test Site (EN 61000-3-2&amp;-3-3)</b>			
<b>Manufacturer/Type</b>	<b>Model No.</b>	<b>Serial No.</b>	<b>Cal. Due</b>
Schaffner / Signal Conditioning Unit	CCN 1000-1	72122	12/05/2005
Schaffner / 5KVA AC Power Source	NSG 1007	55131	No Calibration Required

**Equipment Used for Immunity Measurement**

<b>ESD Test Site (EN 61000-4-2)</b>			
<b>Manufacturer/Type</b>	<b>Model No.</b>	<b>Serial No.</b>	<b>Cal. Due</b>
Schaffner / ESD Simulator	NSG 438	129	04/21/2005
Stockburger / Aneroid Barometer	Barometer	9303	03/30/2005
TOP / Thermo-Hygro meter	HA-202	9303-1	03/24/2005

<b>Radiated Electromagnetic Field Immunity Test Site (EN 61000-4-3)</b>			
<b>Manufacturer/Type</b>	<b>Model No.</b>	<b>Serial No.</b>	<b>Cal. Due</b>
Calibration of Field	Chamber#RS	RS3H-6 / RS3V-6	07/02/2005
Agilent / Signal Generator	E4421B	MY43350597	05/30/2005
AR / Electric Field Probe	FP6001	305657	03/17/2005
Boonton / RF Voltmeter	9200B	328001AE	02/18/2005
BNC / Function Generator	625	25451	02/18/2005
AR / Amplifier	100W1000M1	17564	No Calibration Required
Werlatone Inc. / Direction Coupler	C2630	4121	No Calibration Required
Frankonia / Broadband Antenna	BTA-M	030001M	No Calibration Required
TOP / Thermo-Hygro meter	HA-202	9303-2	03/24/2005

<b>Fast Transients/Burst Test Site (EN 61000-4-4)</b>			
<b>Manufacturer/Type</b>	<b>Model No.</b>	<b>Serial No.</b>	<b>Cal. Due</b>
Schaffner / EFT Generator	BEST EMC V2.3	200031A024SC	11/09/2005
Schaffner / Capacitive Clamp	N/A	N/A	No Calibration Required



<b>Surge Immunity Test Site (EN 61000-4-5)</b>			
<b>Manufacturer/Type</b>	<b>Model No.</b>	<b>Serial No.</b>	<b>Cal. Due</b>
Schaffner / Surger Generator	BEST EMC V2.3	200031A024SC	11/09/2005
Schaffner / Signal and Data Lines Coupling Network	CDN118	19328	No Calibration Required

<b>CS test (EN 61000-4-6)</b>			
<b>Manufacturer/Type</b>	<b>Model No.</b>	<b>Serial No.</b>	<b>Cal. Due</b>
Schaffner / RF Generator	NSG 2070-1	1061	08/02/2005
Schaffner / CDN	CDN M316	19600	08/02/2005
Schaffner / CDN	CDN M216	19294	08/02/2005
Schaffner / EM Clamp	KEMZ 801	19227	03/02/2005
Schaffner / CDN	CDN A800	17885	08/02/2005
Schaffner / CDN	CDN T002	15881	01/30/2005
FCC / CDN	FCC-801-T8-RJ45	04025	06/24/2005
Schaffner / Attenuator	INA2070-1	2061	No Calibration Required
FCC / CDN	FCC-801-T4-RJ45	04031	08/19/2005

<b>Power Frequency Magnetic Field Immunity test (EN 61000-4-8)</b>			
<b>Manufacturer/Type</b>	<b>Model No.</b>	<b>Serial No.</b>	<b>Cal. Due</b>
Schaffner / Induction Coil Interface	INA 21141	6009	No Calibration Required
Schaffner / 5KVA AC Power Source	NSG 1007	55131	No Calibration Required
CHY/ TRMS Clamp Meter	932C	2K0900285	10/12/2005
Sypris / Magnetic Field Meter	4080	0247	02/11/2005

<b>Voltage Dips/Short Interruption and Voltage Variation Immunity test (EN 61000-4-11)</b>			
<b>Manufacturer/Type</b>	<b>Model No.</b>	<b>Serial No.</b>	<b>Cal. Due</b>
Schaffner / Dips/Interruption/Variations Tester	BEST EMC V2.3	200031A024SC	11/09/2005
Protronix / Digital Power Meter	1201	201091	08/31/2005



## 7 LINE CONDUCTED & RADIATED EMISSION TEST

### 7.1 LIMIT

#### Maximum permissible level of Line Conducted Emission

FREQUENCY (MHz)	Class A (dBuV)		Class B (dBuV)	
	Quasi-peak	Average	Quasi-peak	Average
0.15 - 0.5	79	66	66 - 56	56 - 46
0.50 - 5.0	73	60	56	46
5.0 - 30.0	73	60	60	50

*Note: The lower limit shall apply at the transition frequency.*

#### Maximum permissible level of Common Mode Conducted Emission (Telecommunication Ports)

##### CLASS A

FREQUENCY (MHz)	Voltage Limit (dBuV)		Current Limit (dBuA)	
	Quasi-peak	Average	Quasi-peak	Average
0.15 - 0.5	97 - 87	84 - 74	53 - 43	40 - 30
0.5 - 30.0	87	74	43	30

##### CLASS B

FREQUENCY (MHz)	Voltage Limit (dBuV)		Current Limit (dBuA)	
	Quasi-peak	Average	Quasi-peak	Average
0.15 - 0.5	84 - 74	74 - 64	40 - 30	30 - 20
0.5 - 30.0	74	64	30	20

*Note: The lower limit shall apply at the transition frequency.*

#### Maximum permissible level of Radiated Emission measured at 10 meter

FREQUENCY (MHz)	Class A (dBuV/m)	Class B (dBuV/m)
	Quasi-peak	Quasi-peak
30 - 230	40	30
230 - 1000	47	37

*Note: The lower limit shall apply at the transition frequency.*



## **7.2 TEST PROCEDURE OF LINE CONDUCTED EMISSION**

### **Procedure of Preliminary Test**

- The EUT was set up as per the test configuration to simulate typical usage per the user's manual. When the EUT is a tabletop system, a wooden table with a height of 0.8 meters is used and is placed on the ground plane as per EN 55022 (see Test Facility for the dimensions of the ground plane used). When the EUT is a floor-standing equipment, it is placed on the ground plane which has a 3-12 mm non-conductive covering to insulate the EUT from the ground plane.
- Support equipment, if needed, was placed as per EN 55022.
- All I/O cables were positioned to simulate typical actual usage as per EN 55022.
- The test system with EUT received AC power, 230V/50Hz, through a Line Impedance Stabilization Network (LISN), which supplied power source and was grounded to the ground plane.
- All support equipment received power from a second LISN.
- The EUT test program was started. Emissions were measured on each current carrying line of the EUT using an EMI Test Receiver connected to the LISN powering the EUT.
- The Receiver scanned from 150kHz to 30MHz for emissions in each of the test modes.
- During the above scans, the emissions were maximized by cable manipulation.
- The test mode(s) described in Item 3.2 were scanned during the preliminary test.
- After the preliminary scan, we found the test mode described in Item 3.2 producing the highest emission level.
- The EUT configuration and cable configuration of the above highest emission level were recorded for reference of the final test.

### **Procedure of Final Test**

- EUT and support equipment were set up on the test bench as per the configuration with highest emission level in the preliminary test.
- A scan was taken on both power lines, Line 1 and Line 2, recording at least the six highest emissions. Emission frequency and amplitude were recorded into a computer in which correction factors were used to calculate the emission level and compare reading to the applicable limit. If EUT emission level was less -2dB to the Average limit in Q.P. mode, then the emission signal was re-checked using an Average detector.
- The test data of the worst-case condition(s) was recorded.

**Data Sample:**

Freq. MHz	Read Level dBuV	Factor dB	Level dBuV	Limit dBuV	Over Limit dB	Reading Type (P/Q/A)	Line (L1/L2)
x.xx	42.95	0.55	43.50	73	-29.50	Q	L1

- Freq. = Emission frequency in MHz  
 Read Level = Uncorrected Analyzer/Receiver reading  
 Factor = Insertion loss of LISN + Cable Loss  
 Level = Read Level + Factor  
 Limit = Limit stated in standard  
 Over Limit = Reading in reference to limit  
 P = Peak Reading  
 Q = Quasi-peak Reading  
 A = Average Reading  
 L1 = Hot side  
 L2 = Neutral side

**Calculation Formula**

$$\text{Over Limit (dB)} = \text{Level (dBuV)} - \text{Limit (dBuV)}$$

**7.3 TEST PROCEDURE OF COMMON MODE CONDUCTED EMISSION FOR TELECOMMUNICATION PORT**

- Selecting ISN for unscreened cable or a current probe for screened cable to take measurement.
- The port of the EUT was connected to the remote side support equipment through the ISN/Current Probe and communication in normal condition.
- Making a overall range scan by using the test receiver controlled by controller and record at least six highest emissions for showing in the test report.
- Emission frequency and amplitude were recorded into a computer in which correction factors were used to calculate the emission level and compare reading to the applicable limit.
- In case of measuring on the screened cable, the current limit shall be applied, otherwise the voltage limit should be applied.
- The following test mode(s) were scanned during the preliminary test:

**Mode(s):**

- 1 10 Mbps
- 2 100 Mbps
- 3 1Gbps

- After the preliminary scan, we found the following test mode(s) producing the highest emission level and test data of the worst case was recorded.

**Mode: 2.**

**Data Sample:**

Freq. MHz	Read Level dBuV	Factor dB	Level dBuV	Limit dBuV	Over Limit dB	Reading Type (P/Q/A)
x.xx	62.95	0.55	63.50	87	-23.50	Q

- Freq. = Emission frequency in MHz  
 Read Level = Uncorrected Analyzer/Receiver reading  
 Factor = Insertion loss of ISN + Cable Loss  
 Level = Read Level + Factor  
 Limit = Limit stated in standard  
 Over Limit = Reading in reference to limit  
 P = Peak Reading  
 Q = Quasi-peak Reading  
 A = Average Reading

**Calculation Formula**

Over Limit (dB) = Level (dBuV) – Limit (dBuV)

**7.4 TEST PROCEDURE OF RADIATED EMISSION****Procedure of Preliminary Test**

- The equipment was set up as per the test configuration to simulate typical usage per the user's manual. When the EUT is a tabletop system, a wooden turntable with a height of 0.8 meters is used which is placed on the ground plane. When the EUT is a floor-standing equipment, it is placed on the ground plane which has a 3-12 mm non-conductive covering to insulate the EUT from the ground plane.
- Support equipment, if needed, was placed as per EN 55022.
- All I/O cables were positioned to simulate typical usage as per EN 55022.
- The EUT received AC power source, 230V/50Hz, from the outlet socket under the turntable. All support equipment received power from another socket under the turntable.
- Mains cables, telephone lines or other connections to auxiliary equipment located outside the test are shall drape to the floor, be fitted with ferrite clamps or ferrite tubes placed on the floor at the point where the cable reaches the floor and then routed to the place where they leave the turntable. No. extension cords shall be used to mains receptacle.
- The antenna was placed at 10 meter away from the EUT as stated in EN 55022. The antenna connected to the Spectrum Analyzer via a cable and at times a pre-amplifier would be used.
- The Analyzer / Receiver quickly scanned from 30MHz to 1000MHz. The EUT test program was started. Emissions were scanned and measured rotating the EUT to 360 degrees and positioning the antenna 1 to 4 meters above the ground plane, in both the vertical and the horizontal polarization, to maximize the emission reading level.



- The test mode(s) described in Item 3.2 were scanned during the preliminary test:
- After the preliminary scan, we found the test mode described in Item 3.2 producing the highest emission level.
- The EUT and cable configuration, antenna position, polarization and turntable position of the above highest emission level were recorded for the final test.

### **Procedure of Final Test**

- EUT and support equipment were set up on the turntable as per the configuration with highest emission level in the preliminary test.
- The Analyzer / Receiver scanned from 30MHz to 1000MHz. Emissions were scanned and measured rotating the EUT to 360 degrees, varying cable placement and positioning the antenna 1 to 4 meters above the ground plane, in both the vertical and the horizontal polarization, to maximize the emission reading level.
- Recorded at least the six highest emissions. Emission frequency, amplitude, antenna position, polarization and turntable position were recorded into a computer in which correction factors were used to calculate the emission level and compare reading to the applicable limit and only Q.P. reading is presented.

### **Data Sample:**

Freq. MHz	Amptd dBuV/m	Margin dB	Limit dBuV/m	Reading dBuV	Factor dB/m	Reading Type (P/Q/A)	Pol. (H/V)
x.xx	26.2	-13.8	40	14	12.2	Q	H

Freq. = Emission frequency in MHz  
 Reading = Uncorrected Analyzer/Receiver reading  
 Factor = Antenna Factor + Cable Loss + Attenuator (3/6/10dB) – Amplifier Gain  
 Amptd = Uncorrected Analyzer/Receiver reading + Factor  
 Limit = Limit stated in standard  
 Margin = Reading in reference to limit  
 P = Peak Reading  
 Q = Quasi-peak Reading  
 A = Average Reading  
 H = Antenna Polarization: Horizontal  
 V = Antenna Polarization: Vertical

### **Calculation Formula**

Margin (dB) = Amptd (dBuV/m) – Limit (dBuV/m)



## 7.5 TEST RESULTS

### Line Conducted Emission

**Model:** HSB-835P A0.1**Test Mode:** Mode 1**Temperature:** 23 °C**Humidity:** 56% RH**Test Results:** Passed**Tested by:** Sam Hu

(The chart below shows the highest readings taken from the final data, see **Appendix III** for details.)

Six Highest Conducted Emission Readings							
Frequency Range Investigated				150 kHz to 30 MHz			
Freq (MHz)	Read Level (dBuV)	Factor (dB)	Level (dBuV)	Limit Line (dBuV)	Over Limit (dB)	Reading Type (P/Q/A)	Line (L1/L2)
1.178	31.90	0.15	32.05	73.00	-40.95	P	L1
9.451	35.14	0.49	35.63	73.00	-37.37	P	L1
15.552	40.47	0.68	41.16	73.00	-31.84	P	L1
4.797	31.41	0.22	31.63	73.00	-41.37	P	L2
9.603	41.08	0.40	41.48	73.00	-31.52	P	L2
15.226	41.56	0.56	42.12	73.00	-30.88	P	L2

*NOTE: The emission level was or more than 2dB below the Average limit, so no re-check anymore.*

### Common Mode Conducted Emission

**Test Mode:** Mode 2

Six Highest Conducted Emission Readings						
Frequency Range Investigated				150 kHz to 30 MHz		
Freq (MHz)	Read Level (dBuV)	Factor (dB)	Level (dBuV)	Limit Line (dBuV)	Over Limit (dB)	Reading Type (P/Q/A)
5.898	50.32	10.26	60.58	87.00	-26.42	P
9.451	50.52	10.22	60.74	87.00	-26.26	P
12.188	56.66	10.22	66.88	87.00	-20.12	P
13.408	57.53	10.23	67.76	87.00	-19.24	P
15.552	55.75	10.24	65.99	87.00	-21.01	P
16.750	53.98	10.25	64.23	87.00	-22.77	P



**Radiated Emission****Model:** HSB-835P A0.1**Test Mode:** Mode 1**Temperature:** 22°C**Humidity:** 56% RH**Test Results:** Passed**Tested by:** Sam Hu(The chart below shows the highest readings taken from the final data, see **Appendix III** for details.)

<b>Six Highest Radiated Emission Readings</b>							
<b>Frequency Range Investigated</b>				<b>30 MHz to 1000 MHz at 10m</b>			
<b>Freq (MHz)</b>	<b>Amptd (dBuV/m)</b>	<b>Margin (dB)</b>	<b>Limit (dBuV/m)</b>	<b>Reading (dBuV)</b>	<b>Factor (dB/m)</b>	<b>Reading Type (P/Q/A)</b>	<b>Pol. (H/V)</b>
<b>66.5590</b>	<b>29.68</b>	<b>-10.32</b>	<b>40.00</b>	<b>45.86</b>	<b>-16.18</b>	<b>P</b>	<b>V</b>
<b>133.2420</b>	<b>31.06</b>	<b>-8.94</b>	<b>40.00</b>	<b>41.20</b>	<b>-10.14</b>	<b>P</b>	<b>V</b>
<b>366.1000</b>	<b>35.57</b>	<b>-11.43</b>	<b>47.00</b>	<b>39.93</b>	<b>-4.36</b>	<b>P</b>	<b>V</b>
<b>651.1993</b>	<b>37.03</b>	<b>-9.97</b>	<b>47.00</b>	<b>36.38</b>	<b>0.65</b>	<b>P</b>	<b>V</b>
<b>429.9000</b>	<b>35.89</b>	<b>-11.11</b>	<b>47.00</b>	<b>37.88</b>	<b>-1.99</b>	<b>P</b>	<b>H</b>
<b>639.2000</b>	<b>35.98</b>	<b>-11.02</b>	<b>47.00</b>	<b>35.30</b>	<b>0.68</b>	<b>P</b>	<b>H</b>

*NOTE: None.*



## 8 POWER HARMONICS TEST

**Port** : AC mains  
**Basic Standard** : EN 61000-3-2 (2000)  
**Limits** :  CLASS A ;  CLASS D  
**Tested by** : Marion Yu  
**Temperature** : 18°C  
**Humidity** : 52%

### Limit:

Limits for Class A equipment	
Harmonics Order n	Max. permissible harmonics current A
Odd harmonics	
3	2.30
5	1.14
7	0.77
9	0.40
11	0.33
13	0.21
15<=n<=39	0.15x15/n
Even harmonics	
2	1.08
4	0.43
6	0.30
8<=n<=40	0.23x8/n

Limits for Class D equipment		
Harmonics Order n	Max. permissible harmonics current per watt mA/W	Max. permissible harmonics current A
Odd Harmonics only		
3	3.4	2.30
5	1.9	1.14
7	1.0	0.77
9	0.5	0.40
11	0.35	0.33
13	0.30	0.21
15<=n<=39	3.85/n	0.15x15/n

**Block Diagram of Test Setup:**

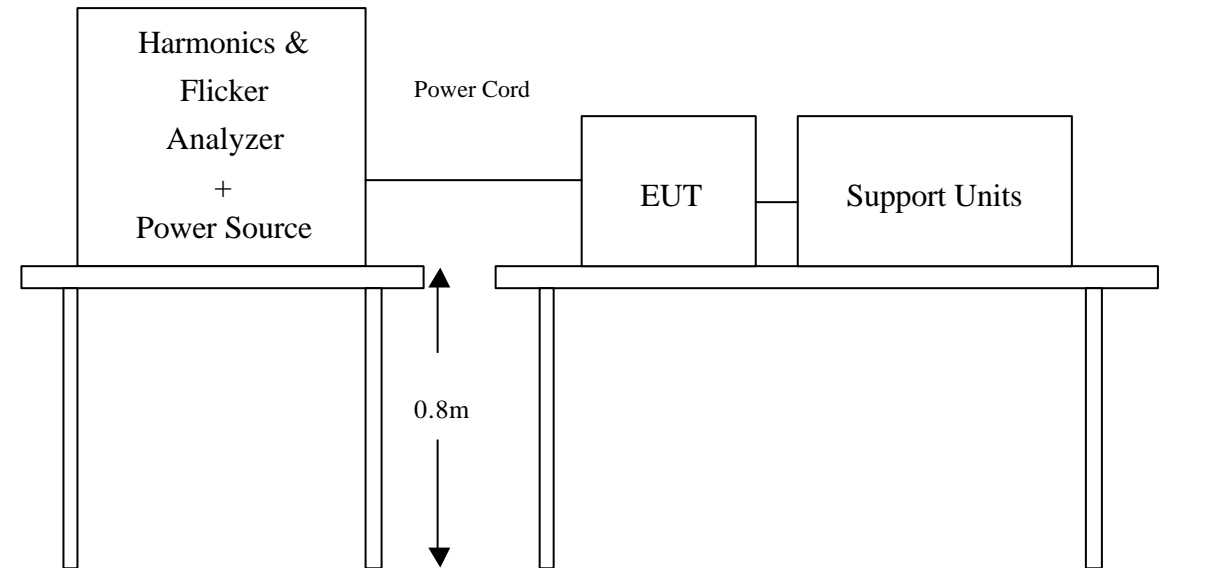

**Test Procedure:**

- a. The EUT was placed on the top of a wooden table 0.8 meters above the ground and operated to produce the maximum harmonic components under normal operating conditions for each successive harmonic component in turn.
- b. The correspondent test program of test instrument to measure the current harmonics emanated from EUT is chosen. The measure time shall be not less than the time necessary for the EUT to be exercised.

**Test Result :** (See Appendix II for details)

<input checked="" type="checkbox"/> <b>PASS</b> <input type="checkbox"/> <b>FAIL</b>
<p><b>Note:</b> No function degraded during the tests.</p>

## 9 POWER VOLTAGE FLUCTUATION / FLICKER TEST

**Port** : AC mains  
**Basic Standard** : EN 61000-3-3 (1995 + A1: 2001)  
**Limits** : § of EN 61000-3-3  
**Tested by** : Marion Yu  
**Temperature** : 18°C  
**Humidity** : 52%

### Limit:

TEST ITEM	LIMIT	REMARK
$P_{st}$	1.0	$P_{st}$ means short-term flicker indicator.
$P_{lt}$	0.65	$P_{lt}$ means long-term flicker indicator.
$T_{dt}$ (ms)	500	$T_{dt}$ means maximum time that dt exceeds 3.3 %.
$d_{max}$ (%)	4%	$d_{max}$ means maximum relative voltage change.
dc (%)	3.3%	dc means relative steady-state voltage change

### Block Diagram of Test Setup:

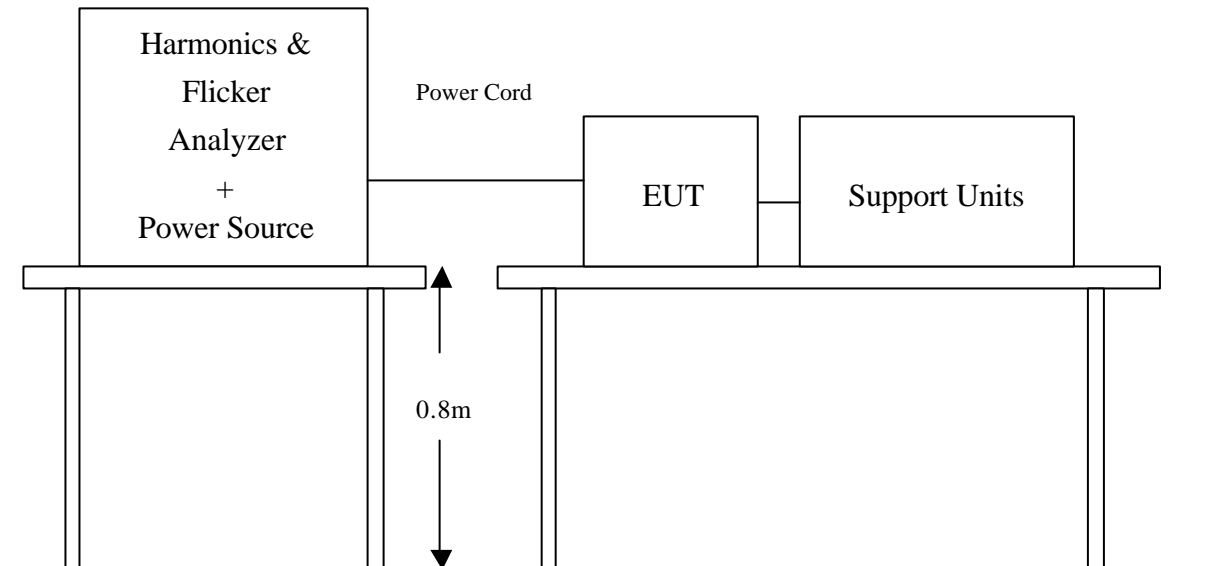

**Test Procedure:**

- a. The EUT was placed on the top of a wooden table 0.8 meters above the ground and operated to produce the most unfavorable sequence of voltage changes under normal operating conditions.
- b. During the flick measurement, the measure time shall include that part of whole operation cycle in which the EUT produce the most unfavorable sequence of voltage changes. The observation period for short-term flicker indicator is 10 minutes and the observation period for long-term flicker indicator is 2 hours.

**Test Result:** (See Appendix II for details)

TEST PARAMETER	MEASUREMENT VALUE	LIMIT	RESULT
$P_{st}$	0.001	1.0	Pass
$P_{lt}$	0.001	0.65	Pass
$T_{dt}$ (ms)	0.0	500	Pass
$d_{max}$ (%)	0.00	4%	Pass
dc (%)	0.14	3.3%	Pass

**Note:** None.

## 10 ELECTROSTATIC DISCHARGE (ESD) IMMUNITY TEST

<b>Port</b>	: Enclosure
<b>Basic Standard</b>	: IEC/EN 61000-4-2
<b>Test Level</b>	: $\pm 8$ kV (Air Discharge) $\pm 4$ kV (Contact Discharge) $\pm 4$ kV (Indirect Discharge)
<b>Performance Criterion</b>	: B (Standard Required)
<b>Tested by</b>	: Marion Yu
<b>Temperature</b>	: 18°C
<b>Humidity</b>	: 52%
<b>Pressure</b>	: 1012mbar

### Block Diagram of Test Setup:

(The 470 k ohm resistors are installed per standard requirement.)

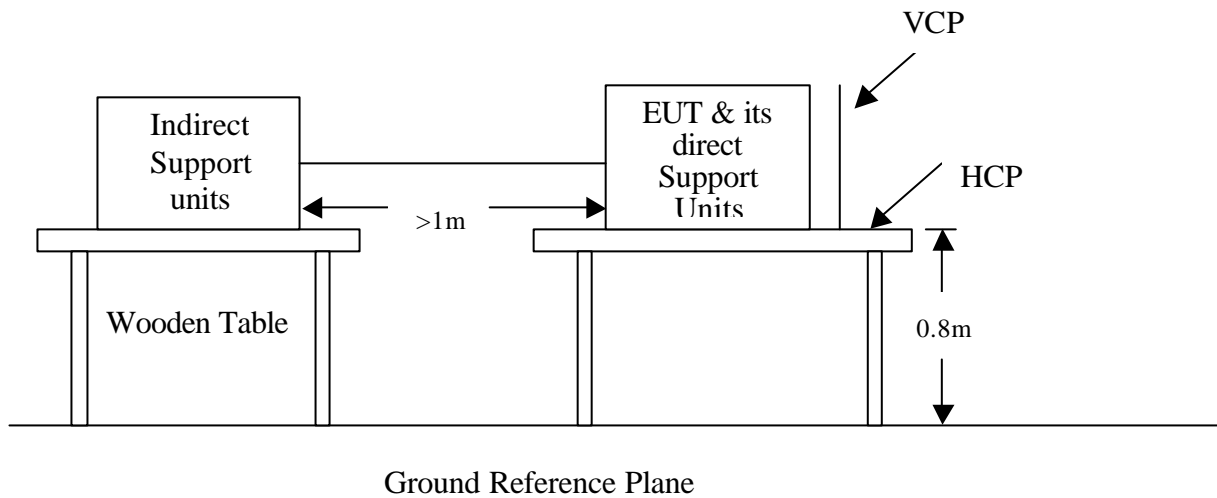

**Test Procedure:**

1. The EUT was located 0.1 m minimum from all sides of the HCP.
2. The indirect support units were located 1 m minimum away from the EUT, but direct support unit was/were located at same location as EUT on the HCP and keep at a distance of 10 cm with EUT.
3. As per the requirement of EN 55024; applying direct contact discharge at the sides other than front of EUT at minimum 50 discharges (25 positive and 25 negative) if applicable, can't be applied direct contact discharge side of EUT then the indirect discharge shall be applied. One of the test points shall be subjected to at least 50 indirect discharge (contact) to the front edge of horizontal coupling plane.
4. Other parts of EUT where it is not possible to perform contact discharge then selecting appropriate points of EUT for air discharge, a minimum of 10 single air discharges shall be applied.
5. The application of ESD to the contact of open connectors is not required.
6. The EUT direct connection units also need to be applied ESD at the port of EUT cable connected.
7. Putting a mark on EUT to show tested points. The following test condition was followed during the tests.

*Note: As per IEC/EN 61000-4-2, two 470k bleed resistors cable is connected between the EUT and HCP during the test applicable for power ungrounded or battery operating unit only.*

The electrostatic discharges were applied as follows:

Amount of discharge	Voltage	Coupling	Result (Pass/Fail)
Mini 10 /Point	± 8 kV	Air Discharge	Pass
Mini 25 /Point	± 4 kV	Contact Discharge	Pass
Mini 25 /Point	± 4 kV	Indirect Discharge HCP (Front)	Pass
Mini 25 /Point	± 4 kV	Indirect Discharge VCP (Right)	Pass
Mini 25 /Point	± 4 kV	Indirect Discharge VCP (Left)	Pass
Mini 25 /Point	± 4 kV	Indirect Discharge VCP (Back)	Pass



**Performance & Result:**

- Criterion A:** The apparatus continues to operate as intended. No degradation of performance or loss of function is allowed below a performance level specified by the manufacturer, when the apparatus is used as intended. In some cases the performance level may be replaced by a permissible loss of performance.
- Criterion B:** The apparatus continues to operate as intended after the test. No degradation of performance or loss of function is allowed below a performance level specified by the manufacturer, when the apparatus is used as intended. In some cases the performance level may be replaced by a permissible loss of performance. During the test, degradation of performance is however allowed.
- Criterion C:** Temporary loss of function is allowed, provided the functions self recoverable or can be restored by the operation of controls.

<input checked="" type="checkbox"/> <b>PASS</b> <input type="checkbox"/> <b>FAIL</b>
<b>Observation:</b> No function degraded during the tests.



# 11 RADIATED ELECTROMAGNETIC FIELD IMMUNITY TEST

**Port** : Enclosure  
**Basic Standard** : IEC/EN 61000-4-3  
**Requirements** : 3 V/m / with 80% AM. 1kHz Modulation.  
**Performance Criterion:** A (Standard Required)  
**Tested by** : Marion Yu  
**Temperature** : 18°C  
**Humidity** : 52%  
**Pressure** : 1012mbar

## Block Diagram of Test Setup:

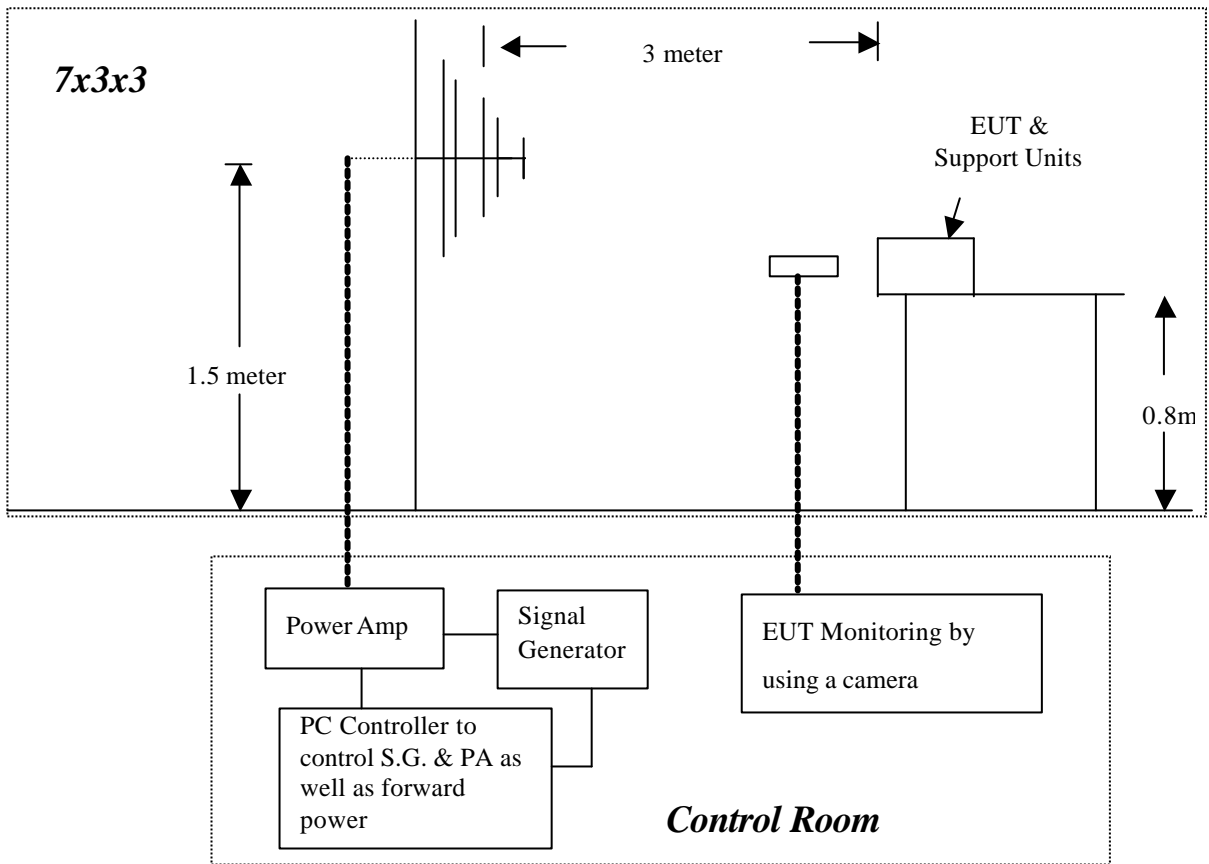

**Test Procedure:**

1. The EUT and support units were located at the edge of supporting table keep 3 meter away from transmitting antenna, it just the calibrated square area of field uniformity.
2. Adjusting the cables to be exposed to the electromagnetic field as possible.
3. Performing a Radiated Emission Scan in range of 80 to 1000 MHz prior to do RS test and records the more higher emission frequencies for the reference of RS test, due to antenna effectiveness.
4. Adjusting the monitoring camera to monitor the “H” message as clear as possible.
5. Setting the testing parameters of RS test software per IEC 61000-4-3.
6. Referring to the tested data of step 3 to performing the RS test from 80 to 1000 MHz.
7. Recording the test result in following table.
8. Changing the EUT to the other side and repeat step 3 to 6, until 4 sides of EUT were verified.

**IEC 61000-4-3 Final test conditions:**

Test level : 3V/m  
 Steps : 1 % of fundamental  
 Dwell Time : 3 sec

Range (MHz)	Field	Modulation	Polarity	Position (°)	Result (Pass/Fail)
80-1000	3V/m	Yes	H	Front	Pass
80-1000	3V/m	Yes	V	Front	Pass
80-1000	3V/m	Yes	H	Right	Pass
80-1000	3V/m	Yes	V	Right	Pass
80-1000	3V/m	Yes	H	Back	Pass
80-1000	3V/m	Yes	V	Back	Pass
80-1000	3V/m	Yes	H	Left	Pass
80-1000	3V/m	Yes	V	Left	Pass



**Performance & Result:**

- Criterion A:** The apparatus continues to operate as intended. No degradation of performance or loss of function is allowed below a performance level specified by the manufacturer, when the apparatus is used as intended. In some cases the performance level may be replaced by a permissible loss of performance.
- Criterion B:** The apparatus continues to operate as intended after the test. No degradation of performance or loss of function is allowed below a performance level specified by the manufacturer, when the apparatus is used as intended. In some cases the performance level may be replaced by a permissible loss of performance. During the test, degradation of performance is however allowed.
- Criterion C:** Temporary loss of function is allowed, provided the functions self recoverable or can be restored by the operation of controls.

<input checked="" type="checkbox"/> <b>PASS</b> <input type="checkbox"/> <b>FAIL</b>
<b>Observation:</b> No function degraded during the tests.

## 12 FAST TRANSIENTS/BURST IMMUNITY TEST

<b>Port</b>	: On Power Supply Lines and Data Line
<b>Basic Standard</b>	: IEC/EN 61000-4-4
<b>Requirements</b>	: $\pm 1$ kV for Power Supply Line $\pm 0.5$ kV to Data Line
<b>Performance Criteria</b>	: B (Standard Required)
<b>Tested by</b>	: Marion Yu
<b>Temperature</b>	: 18°C
<b>Humidity</b>	: 52%
<b>Pressure</b>	: 1012mbar

### Block Diagram of Test Setup:

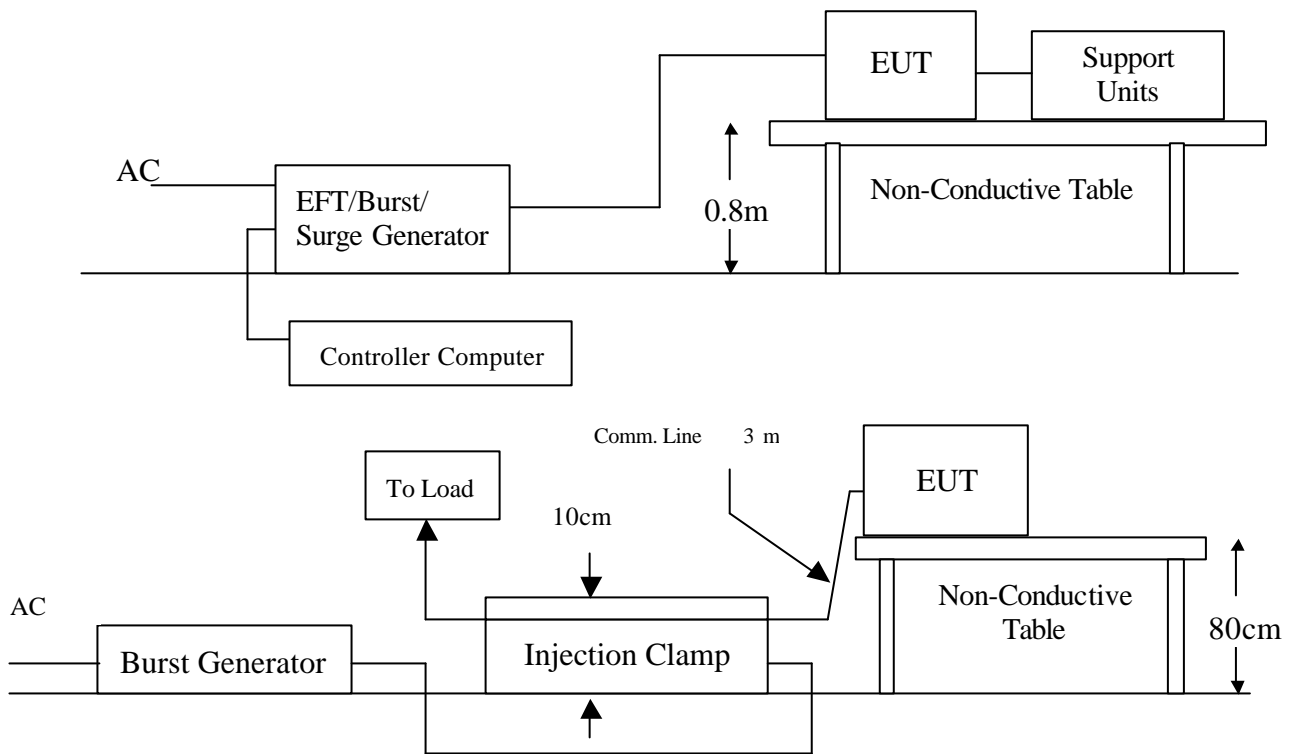

### Test Procedure:

1. The EUT and support units were located on a wooden table 0.8 m away from ground reference plane.
2. A 1.0 meter long power cord was attached to EUT during the test.
3. The length of communication cable between communication port and clamp was keeping within 1 meter.
4. Injected test voltage to the EUT ports from minimum to standard request or client request.
5. Recorded the test result as shown in following table.

**Test conditions:**

Impulse Frequency : 5kHz  
 Tr/Th : 5/50ns  
 Burst Duration : 15ms  
 Burst Period : 300ms

Inject Line	Voltage kV	Inject Method	Result (Pass/Fail)
L	± 1	Direct	Pass
N	± 1	Direct	Pass
PE	± 1	Direct	Pass
L + N	± 1	Direct	Pass
L + PE	± 1	Direct	Pass
N + PE	± 1	Direct	Pass
L + N + PE	± 1	Direct	Pass
RJ45	±0.5	Clamp	Pass

**Performance & Result:**

- Criterion A:** The apparatus continues to operate as intended. No degradation of performance or loss of function is allowed below a performance level specified by the manufacturer, when the apparatus is used as intended. In some cases the performance level may be replaced by a permissible loss of performance.
- Criterion B:** The apparatus continues to operate as intended after the test. No degradation of performance or loss of function is allowed below a performance level specified by the manufacturer, when the apparatus is used as intended. In some cases the performance level may be replaced by a permissible loss of performance. During the test, degradation of performance is however allowed.
- Criterion C:** Temporary loss of function is allowed, provided the functions self recoverable or can be restored by the operation of controls.

**PASS**       **FAIL**

**Observation:** No function degraded during the tests.

## 13 SURGE IMMUNITY TEST

<b>Port</b>	: Power Cord
<b>Basic Standard</b>	: IEC/EN 61000-4-5
<b>Requirements</b>	: $\pm 1$ kV (Line to Line) $\pm 2$ kV (Line to Ground)
<b>Performance Criteria</b>	: B (Standard Required)
<b>Tested by</b>	: Marion Yu
<b>Temperature</b>	: 18°C
<b>Humidity</b>	: 52%
<b>Pressure</b>	: 1012mbar

### Block Diagram of Test Setup:

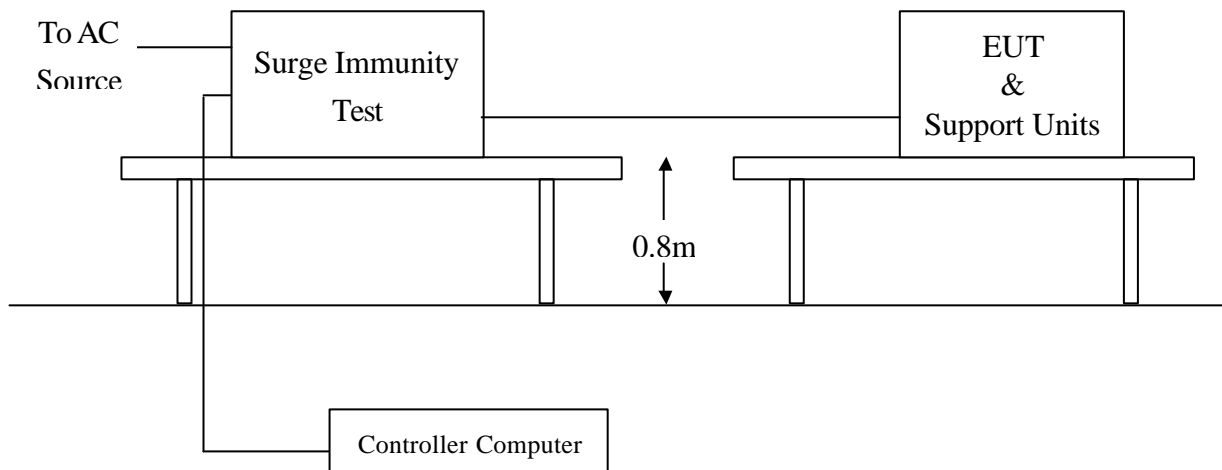

### Test Procedure:

1. The EUT and support units were located on a wooden table 0.8 m away from ground floor.
2. Injected test voltage to the EUT ports from minimum to standard request or client request.
3. Recorded the test result as shown in following table.

**Test conditions:**

Voltage Waveform : 1.2/50 *us*  
 Current Waveform : 8/20 *us*  
 Polarity : Positive/Negative  
 Phase angle : 0°, 90°, 270°  
 Number of Test : 5

Coupling Line	Voltage (kV)	Polarity	Coupling Method	Result (Pass/Fail)
L1-L2	1	Positive	Capacitive	Pass
L1-PE	2	Positive	Capacitive	Pass
L2-PE	2	Positive	Capacitive	Pass
L1-L2	1	Negative	Capacitive	Pass
L1-PE	2	Negative	Capacitive	Pass
L2-PE	2	Negative	Capacitive	Pass

**Performance & Result:**

- Criterion A:** The apparatus continues to operate as intended. No degradation of performance or loss of function is allowed below a performance level specified by the manufacturer, when the apparatus is used as intended. In some cases the performance level may be replaced by a permissible loss of performance.
- Criterion B:** The apparatus continues to operate as intended after the test. No degradation of performance or loss of function is allowed below a performance level specified by the manufacturer, when the apparatus is used as intended. In some cases the performance level may be replaced by a permissible loss of performance. During the test, degradation of performance is however allowed.
- Criterion C:** Temporary loss of function is allowed, provided the functions self recoverable or can be restored by the operation of controls.

**PASS**       **FAIL**

**Observation:** Where normal functioning of LAN can't be achieved because of the impact of CDN on the EUT, no test be required.

## 14 CONDUCTED DISTURBANCE/INDUCED RADIO-FREQUENCY FIELD IMMUNITY TEST

<b>Port</b>	: AC Port and Line Cable
<b>Basic Standard</b>	: IEC/EN 61000-4-6
<b>Requirements</b>	: 3 V, with 80% AM. 1kHz Modulation.
<b>Injection Method</b>	: CDN-M3 for Power Cord CDN-T4&T8 for RJ45 Cable
<b>Performance Criterion</b>	: A (Standard Required)
<b>Tested by</b>	: Marion Yu
<b>Temperature</b>	: 18°C
<b>Humidity</b>	: 52%
<b>Pressure</b>	: 1012mbar

### Block Diagram of Test Setup:

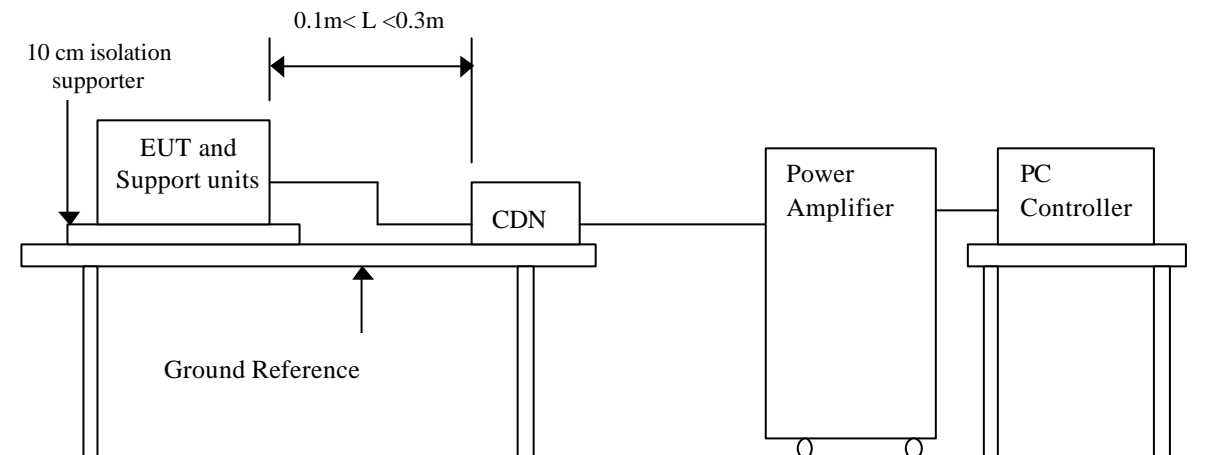

### Test Procedure:

1. The EUT and support units were located at a ground reference plane with the interposition of a 0.1 m thickness insulating support and the CDN was located on GRP directly.
2. Set the testing parameters of CS test software as per IEC/EN 61000-4-6.
3. Recorded the test result in following table.





**Test conditions:**

Frequency Range : 0.15MHz-80MHz

Frequency Step : 1% of fundamental

Dwell Time : 3 sec

Range (MHz)	Field	Modulation	Result (Pass/Fail)
0.15-80	3V	Yes	Pass

**Performance & Result:**

**Criterion A:** The apparatus continues to operate as intended. No degradation of performance or loss of function is allowed below a performance level specified by the manufacturer, when the apparatus is used as intended. In some cases the performance level may be replaced by a permissible loss of performance.

**Criterion B:** The apparatus continues to operate as intended after the test. No degradation of performance or loss of function is allowed below a performance level specified by the manufacturer, when the apparatus is used as intended. In some cases the performance level may be replaced by a permissible loss of performance. During the test, degradation of performance is however allowed.

**Criterion C:** Temporary loss of function is allowed, provided the functions self recoverable or can be restored by the operation of controls.

<input checked="" type="checkbox"/> <b>PASS</b> <input type="checkbox"/> <b>FAIL</b>
<b>Observation:</b> No function degraded during the tests.

## 15 POWER FREQUENCY MAGNETIC FIELD IMMUNITY TEST

Port	: Enclosure
Basic Standard	: IEC/EN 61000-4-8
Requirements	: 1 A/m
Performance Criterion	: A (Standard Required)
Tested by	: N/A
Temperature	: N/A
Humidity	: N/A
Pressure	: N/A

### Block Diagram of Test Setup:

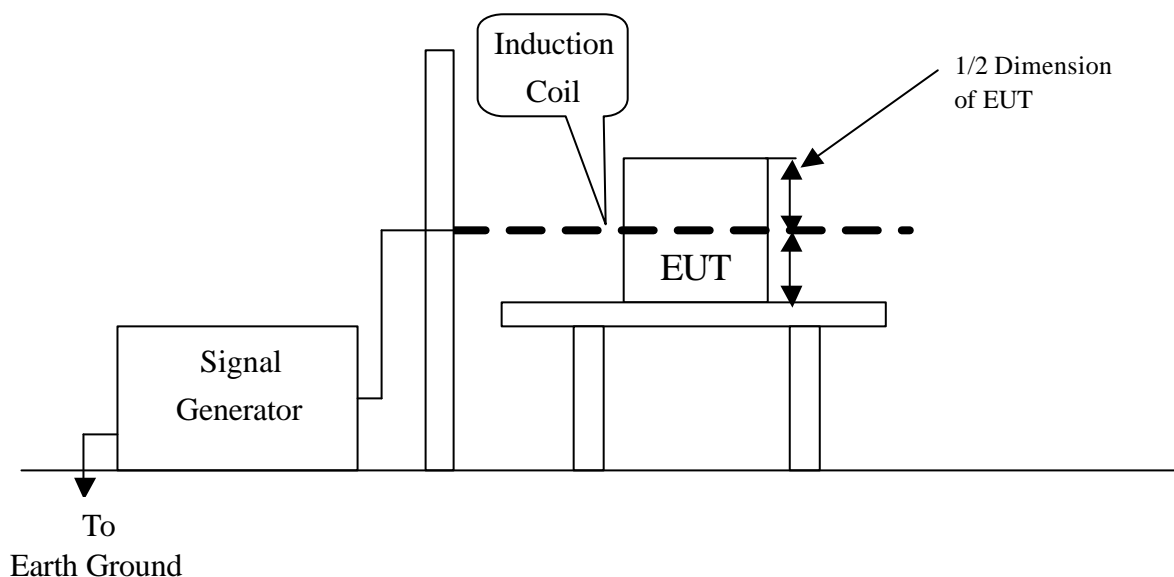

### Test Procedure:

1. The EUT and support units were located on Ground Reference Plane with the interposition of a 0.1 m thickness insulation support.
2. Put the induction coil on horizontal direction. ( X direction )
3. Recorded the test result as shown in following table.
4. Rotated the induction coil by 90° ( Y direction ) then repeat step 3.
5. Rotated the induction coil by 90° ( Z direction ) then repeat step 3.



**Test conditions:**

Field Strength: 1A/m  
Power Freq.: 50Hz  
Orientation: X, Y, Z

Orientation	Field	Result (Pass/Fail)	Remark

**Performance & Result:**

- Criterion A:** The apparatus continues to operate as intended. No degradation of performance or loss of function is allowed below a performance level specified by the manufacturer, when the apparatus is used as intended. In some cases the performance level may be replaced by a permissible loss of performance.
- Criterion B:** The apparatus continues to operate as intended after the test. No degradation of performance or loss of function is allowed below a performance level specified by the manufacturer, when the apparatus is used as intended. In some cases the performance level may be replaced by a permissible loss of performance. During the test, degradation of performance is however allowed.
- Criterion C:** Temporary loss of function is allowed, provided the functions self recoverable or can be restored by the operation of controls.

<input type="checkbox"/> <b>PASS</b> <input type="checkbox"/> <b>FAIL</b>
<b>Observation:</b> The EUT is not containing any component that is susceptible to a 50 Hz or 60 Hz magnetic field. Therefore, this requirement is not applicable to the EUT.

## 16 VOLTAGE DIPS / SHORT INTERRUPTIONS

**Port** : AC mains  
**Basic Standard** : IEC/EN 61000-4-11  
**Requirement** : PHASE ANGLE 0, 45, 90, 135, 180, 225, 270, 315 degrees  
**Test Interval** : Min. 10 sec.  
**Tested by** : Marion Yu  
**Temperature** : 18°C  
**Humidity** : 52%  
**Pressure** : 1012mbar

Voltage Dips	Test Level % $U_T$	Reduction (%)	Duration ( periods )	Performance Criterion
	<5	>95	0.5	B
	70	30	25	C

Voltage Interceptions	Test Level % $U_T$	Reduction (%)	Duration ( periods )	Performance Criterion
	<5	>95	250	C

### Block Diagram of Test Setup:

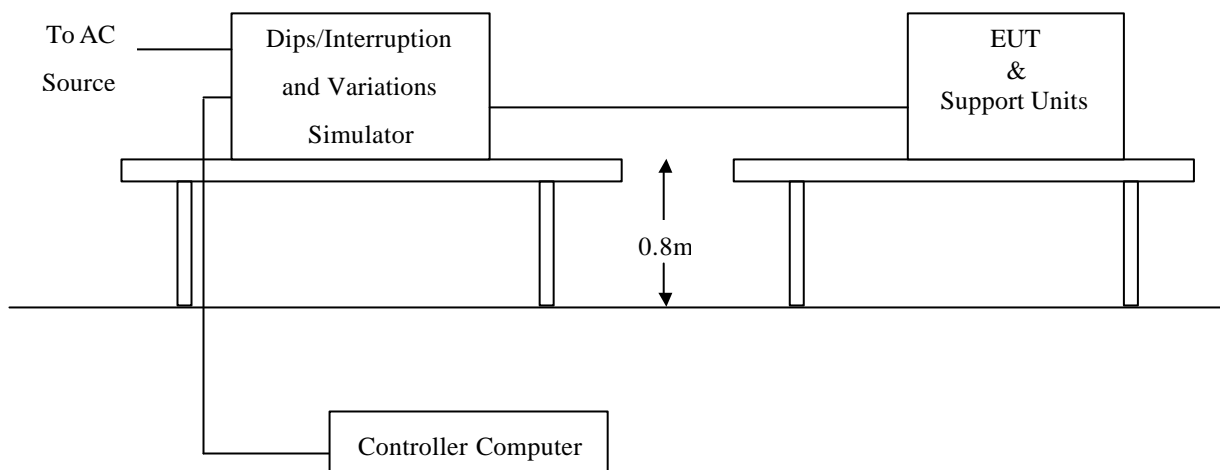

### Test Procedure:

1. The EUT and support units were located on a wooden table, 0.8 m away from ground floor.
2. Set the parameter of tests and then Performed the test software of test simulator.
3. Changed Condition to occur at 0 degree crossover point of the voltage waveform.
4. Recorded the test result in test record form.

**Test conditions:**

The duration with a sequence of three dips/interruptions with interval of 10 sec. minimum  
(Between each test event )

**Voltage Dips:**

Test Level % U <sub>T</sub>	Reduction (%)	Duration (periods)	Observation	Meet Performance Criterion
0	100	0.5	Normal	A
70	30	25	Normal	A

**Voltage Interruptions:**

Test Level % U <sub>T</sub>	Reduction (%)	Duration (periods)	Observation	Meet Performance Criterion
0	100	250	EUT shut down, but EUT can be auto recovered after it restart.	C

**Note:** "Normal" means no any functions degrade during and after the test.

**Performance & Result:**

**Criterion A:** The apparatus continues to operate as intended. No degradation of performance or loss of function is allowed below a performance level specified by the manufacturer, when the apparatus is used as intended. In some cases the performance level may be replaced by a permissible loss of performance.

**Criterion B:** The apparatus continues to operate as intended after the test. No degradation of performance or loss of function is allowed below a performance level specified by the manufacturer, when the apparatus is used as intended. In some cases the performance level may be replaced by a permissible loss of performance. During the test, degradation of performance is however allowed.

**Criterion C:** Temporary loss of function is allowed, provided the functions self recoverable or can be restored by the operation of controls.

**PASS**       **FAIL**

**Observation:** No function degraded during the tests.

## APPENDIX I - PHOTOGRAPHS OF TEST SETUP

### LINE CONDUCTED EMISSION TEST (EN 55022)





## COMMON MODE CONDUCTED EMISSION TEST



## RADIATED EMISSION TEST





## POWER HARMONIC & VOLTAGE FLUCTUATION / FLICKER TEST



## ELECTROSTATIC DISCHARGE TEST



## RADIATED ELECTROMAGNETIC FIELD TEST

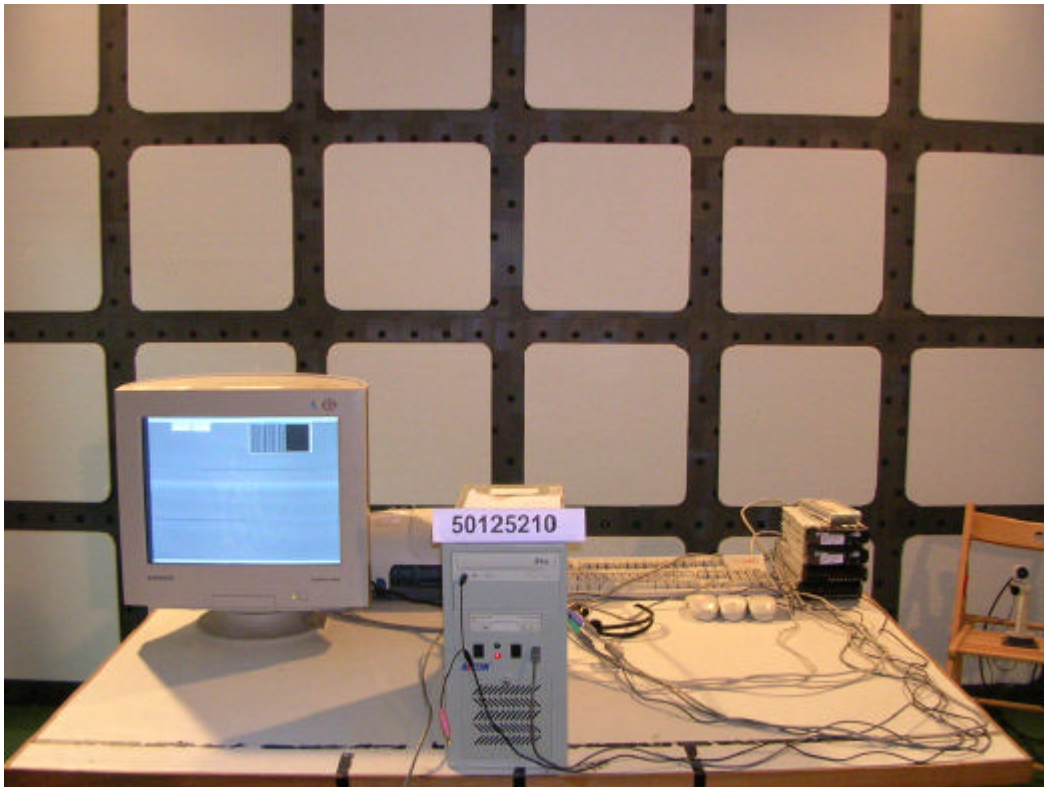

## FAST TRANSIENTS/BURST TEST





**(IEC 61000-4-4 FOR I/O)**



**SURGE IMMUNITY TEST**



## CONDUCTED DISTURBANCE, INDUCED BY RADIO-FREQUENCY FIELDS TEST



**(IEC 61000-4-6 FOR I/O)**







## VOLTAGE DIPS / INTERRUPTION TEST





## APPENDIX II – TEST RESULT OF EN 61000-3-3

Test Result: Pass

Source qualification: Normal

### Current & voltage waveforms

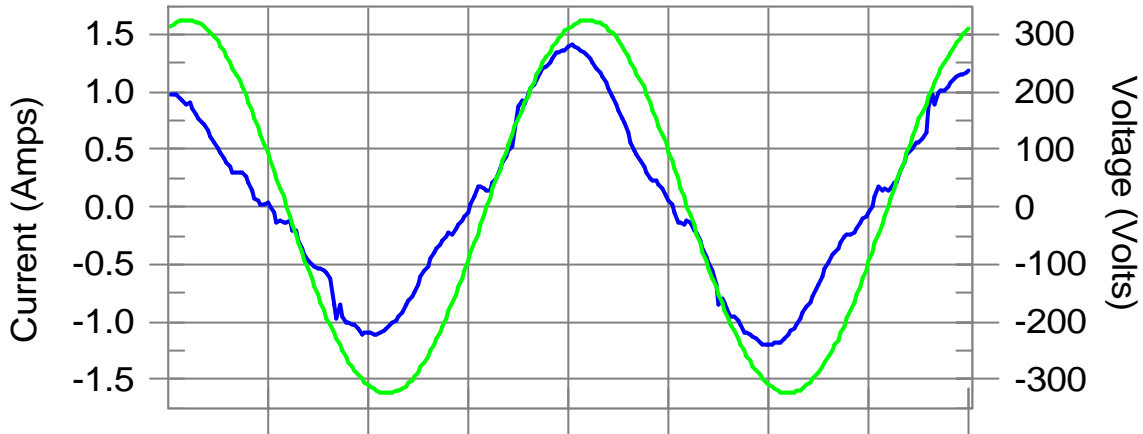

### Harmonics and Class D limit line

### European Limits

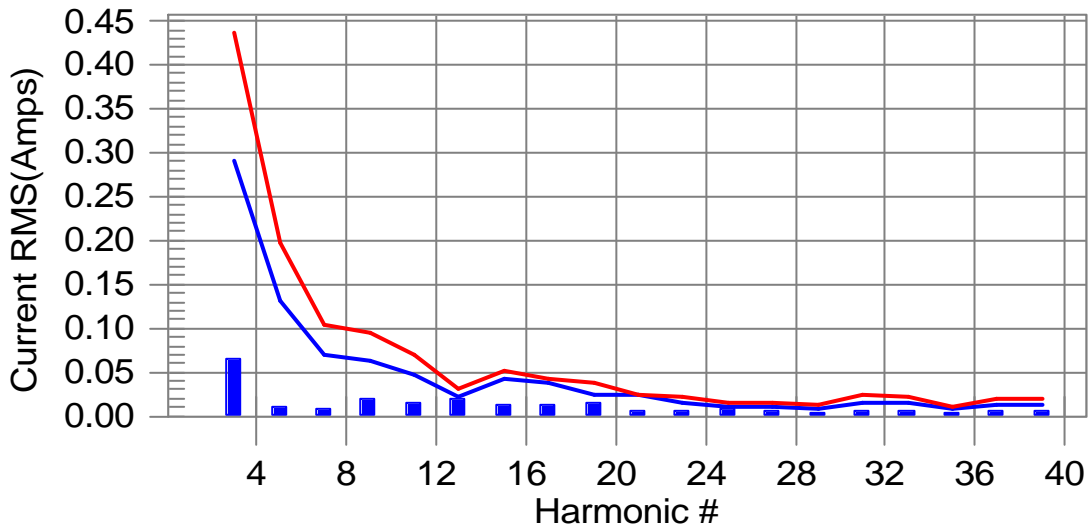

Test result: Pass

Worst harmonic was #13 with 60.42 % of the limit.



Test Result: Pass

Source qualification: Normal

THC(A): 0.109

I THD(pk%): 23.272

POHC(A): N/A

POHC Limit(A): N/A

Highest parameter values during test:

V\_RMS (Volts): 230.16

I\_Peak (Amps): 1.406

I\_RMS (Amps): 0.793

I\_Fund (Amps): 0.795

Crest Factor: 2.743

Power (Watts): 176

Power Factor: 0.964

Harm#	Harms(avg)	100%Limit	%of Limit	Harms(max)	150%Limit	%of Limit	Status
2	0.000						
3	0.051	0.291	21.8	0.065	0.436	14.81	Pass
4	0.000						
5	0.009	0.132	7.0	0.010	0.198	4.81	Pass
6	0.000						
7	0.008	0.070	12.2	0.009	0.104	8.37	Pass
8	0.000						
9	0.009	0.063	26.0	0.019	0.094	19.93	Pass
10	0.000						
11	0.006	0.046	24.2	0.016	0.070	22.91	Pass
12	0.000						
13	0.018	0.021	86.5	0.019	0.031	60.42	Pass
14	0.000						
15	0.010	0.043	22.2	0.014	0.051	26.90	Pass
16	0.000						
17	0.008	0.038	19.7	0.012	0.043	27.63	Pass
18	0.000						
19	0.007	0.025	48.8	0.014	0.038	37.49	Pass
20	0.000						
21	0.005	0.024	18.9	0.006	0.024	26.61	Pass
22	0.000						
23	0.002	0.014	20.4	0.005	0.021	23.76	Pass
24	0.000						
25	0.007	0.011	65.6	0.009	0.016	53.52	Pass
26	0.000						
27	0.005	0.010	54.2	0.006	0.015	40.19	Pass
28	0.000						
29	0.004	0.009	45.1	0.005	0.014	32.71	Pass
30	0.000						
31	0.002	0.016	24.1	0.007	0.023	28.78	Pass
32	0.000						
33	0.002	0.015	20.9	0.006	0.023	27.47	Pass
34	0.000						
35	0.004	0.008	48.1	0.004	0.011	33.15	Pass
36	0.000						
37	0.002	0.014	15.0	0.006	0.020	28.51	Pass
38	0.000						
39	0.002	0.013	16.5	0.005	0.020	27.10	Pass
40	0.000						



Test Result: Pass

Source qualification: Normal

Highest parameter values during test:

Voltage (Vrms): 230.16

I\_Peak (Amps): 1.406

I\_RMS (Amps): 0.793

I\_Fund (Amps): 0.795

Crest Factor: 2.743

Power (Watts): 176

Power Factor: 0.964

Harm#	Harmonics V-rms	Limit V-rms	% of Limit	Status
2	0.135	0.459	29.42	OK
3	0.407	2.067	19.68	OK
4	0.052	0.459	11.31	OK
5	0.047	0.919	5.09	OK
6	0.096	0.460	20.92	OK
7	0.042	0.690	6.09	OK
8	0.041	0.459	8.83	OK
9	0.073	0.459	15.84	OK
10	0.029	0.460	6.32	OK
11	0.060	0.230	26.12	OK
12	0.029	0.230	12.57	OK
13	0.079	0.230	34.54	OK
14	0.027	0.230	11.87	OK
15	0.056	0.230	24.27	OK
16	0.022	0.230	9.58	OK
17	0.025	0.230	10.70	OK
18	0.029	0.230	12.61	OK
19	0.026	0.230	11.28	OK
20	0.033	0.230	14.29	OK
21	0.034	0.230	14.92	OK
22	0.022	0.230	9.46	OK
23	0.069	0.230	30.00	OK
24	0.041	0.230	17.73	OK
25	0.179	0.230	78.00	OK
26	0.052	0.230	22.59	OK
27	0.078	0.230	33.78	OK
28	0.040	0.230	17.24	OK
29	0.046	0.230	20.19	OK
30	0.053	0.230	23.16	OK
31	0.018	0.230	7.68	OK
32	0.019	0.230	8.16	OK
33	0.016	0.230	6.81	OK
34	0.016	0.230	7.16	OK
35	0.017	0.230	7.47	OK
36	0.009	0.230	3.87	OK
37	0.019	0.230	8.26	OK
38	0.007	0.230	3.09	OK
39	0.011	0.230	4.94	OK
40	0.010	0.230	4.46	OK





Test Result: Pass

Status: Test Completed

Pst, and limit line

European Limits

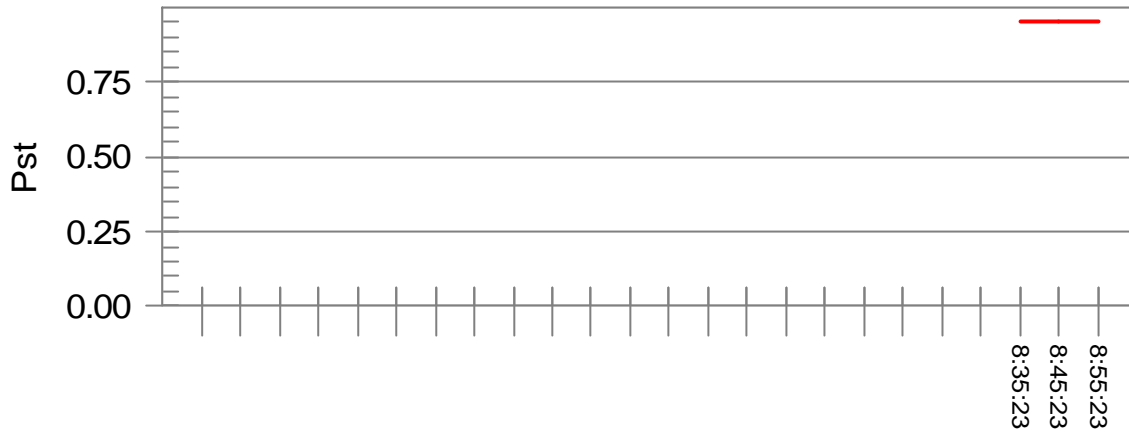

Time is too short for Plt plot

Parameter values recorded during the test:

Vrms at the end of test (Volt):	229.41			
Highest dt (%):	0.00	Test limit (%):	3.14	Pass
Time(mS) > dt:	0.0	Test limit (mS):	500.0	Pass
Highest dc (%):	0.14	Test limit (%):	3.14	Pass
Highest dmax (%):	0.00	Test limit (%):	3.80	Pass
Highest Pst (10 min. period):	0.001	Test limit:	0.950	Pass
Highest Plt (2 hr. period):	0.001	Test limit:	0.617	Pass



## **APPENDIX III - TEST RESULT OF FINAL DATAS**

### **Conducted Emission Plot**

### **Radiated Emission Data**

Data#: 12 File#: 50125210C.EMI

Date: 2005-01-26 Time: 14:39:13

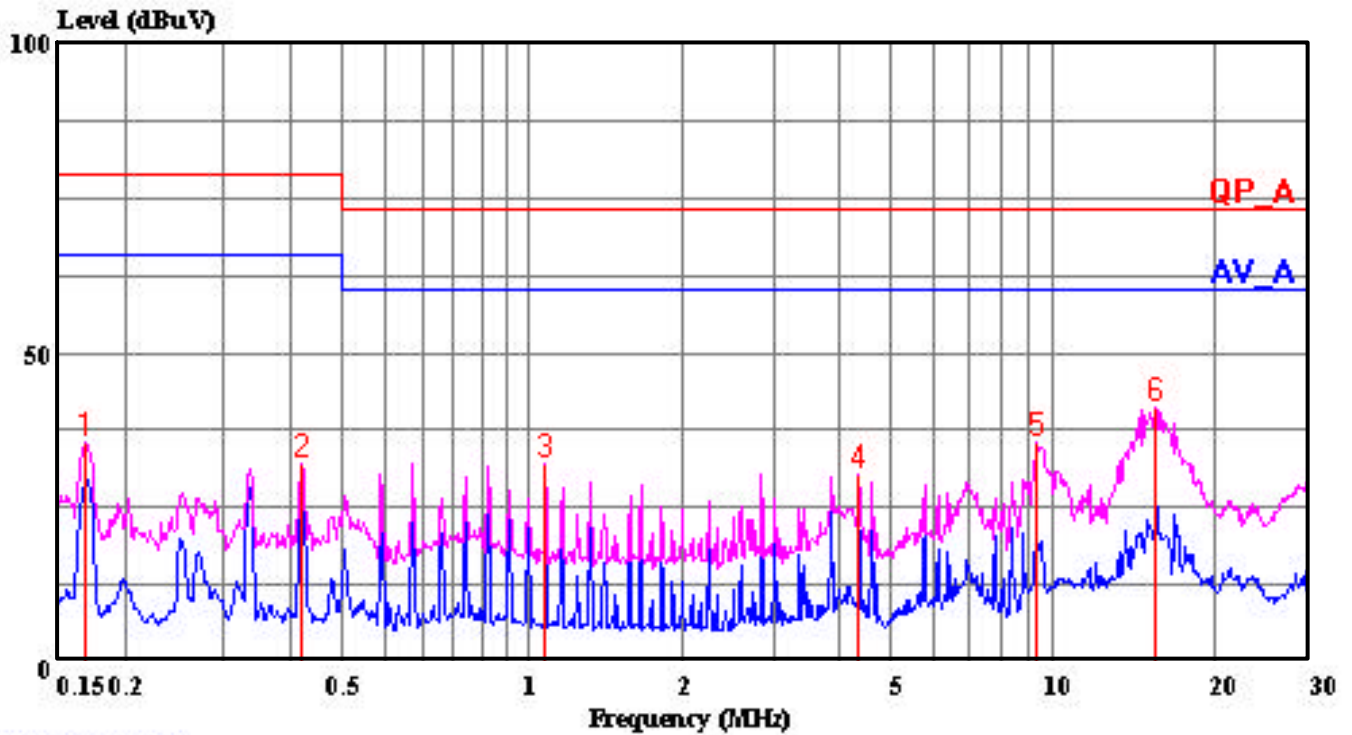

**(Conduction A)**

Trace: 11 10

Ref Trace:

Condition: LINE  
Report No. : 50125210  
Test Engr. : SAM HU  
Company : AAEON Technology Inc.  
EUT : HSB-835P A0.1  
Test Config : EUT / ALL PERIPHERALS  
Type of Test: EN 55022 CLASS A  
Mode of Op. : Normal Mode

Page: 1

	Read	Limit	Over			
Freq	Level	Factor	Level	Line	Limit	Remark
MHz	dBuV	dB	dBuV	dBuV	dB	
1	0.169	35.31	0.11	35.42	79.00	-43.58 Peak
2	0.421	31.93	0.12	32.05	79.00	-46.95 Peak
3	1.178	31.90	0.15	32.05	73.00	-40.95 Peak
4	4.454	30.03	0.22	30.25	73.00	-42.75 Peak
5	9.451	35.14	0.49	35.63	73.00	-37.37 Peak
6	15.552	40.47	0.68	41.16	73.00	-31.84 Peak

Data#: 9 File#: 50125210C.EMI

Date: 2005-01-26 Time: 14:33:26

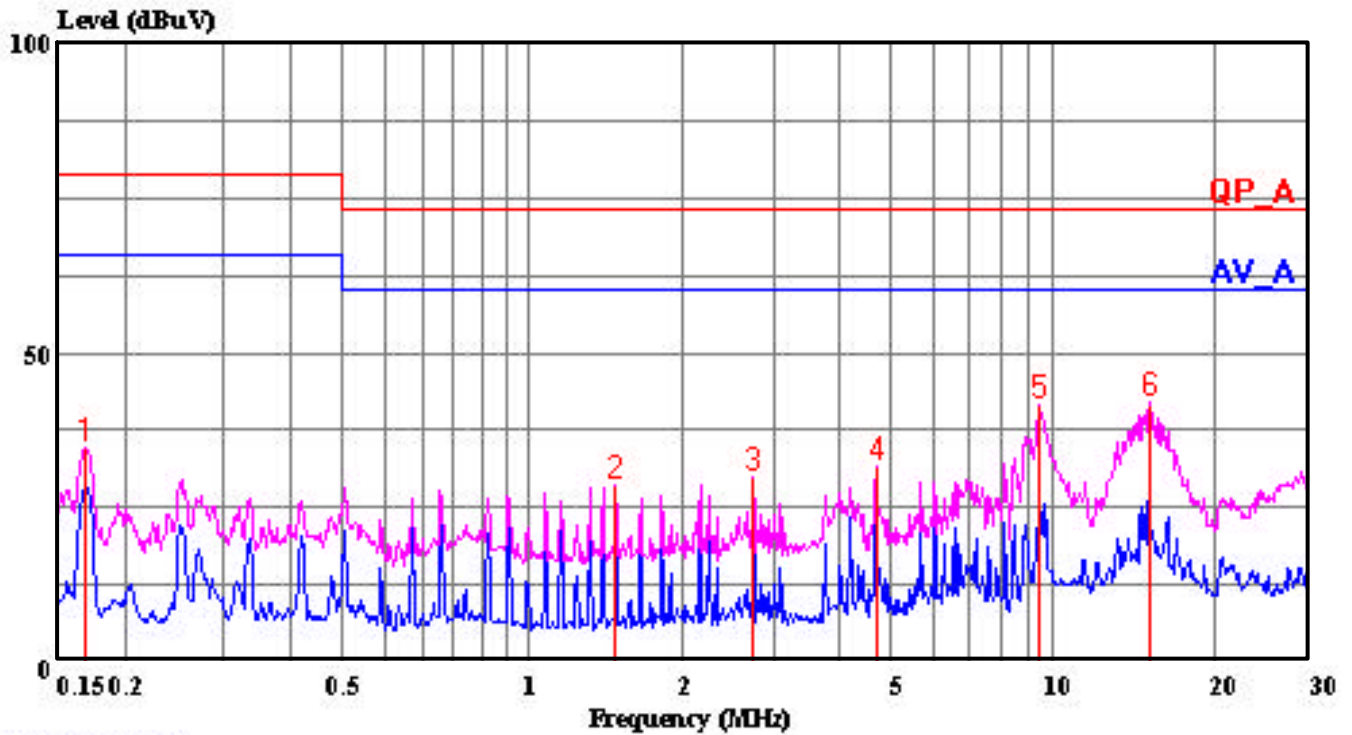

**(Conduction A)**

Trace: 8 7

Ref Trace:

Condition: NEUTRAL  
Report No. : 50125210  
Test Engr. : SAM HU  
Company : AAEON Technology Inc.  
EUT : HSB-835P A0.1  
Test Config : EUT / ALL PERIPHERALS  
Type of Test: EN 55022 CLASS A  
Mode of Op. : Normal Mode

Page: 1

	Read	Read	Limit	Over		
Freq	Level	Factor	Level	Line	Limit	Remark
MHz	dBuV	dB	dBuV	dBuV	dB	
1	0.168	34.38	0.11	34.49	79.00	-44.51 Peak
2	1.593	28.21	0.16	28.37	73.00	-44.63 Peak
3	2.854	29.59	0.17	29.76	73.00	-43.24 Peak
4	4.797	31.41	0.22	31.63	73.00	-41.37 Peak
5	9.603	41.08	0.40	41.48	73.00	-31.52 Peak
6	15.226	41.56	0.56	42.12	73.00	-30.88 Peak

Data#: 18 File#: 50125210C.EMI

Date: 2005-01-26 Time: 14:53:25

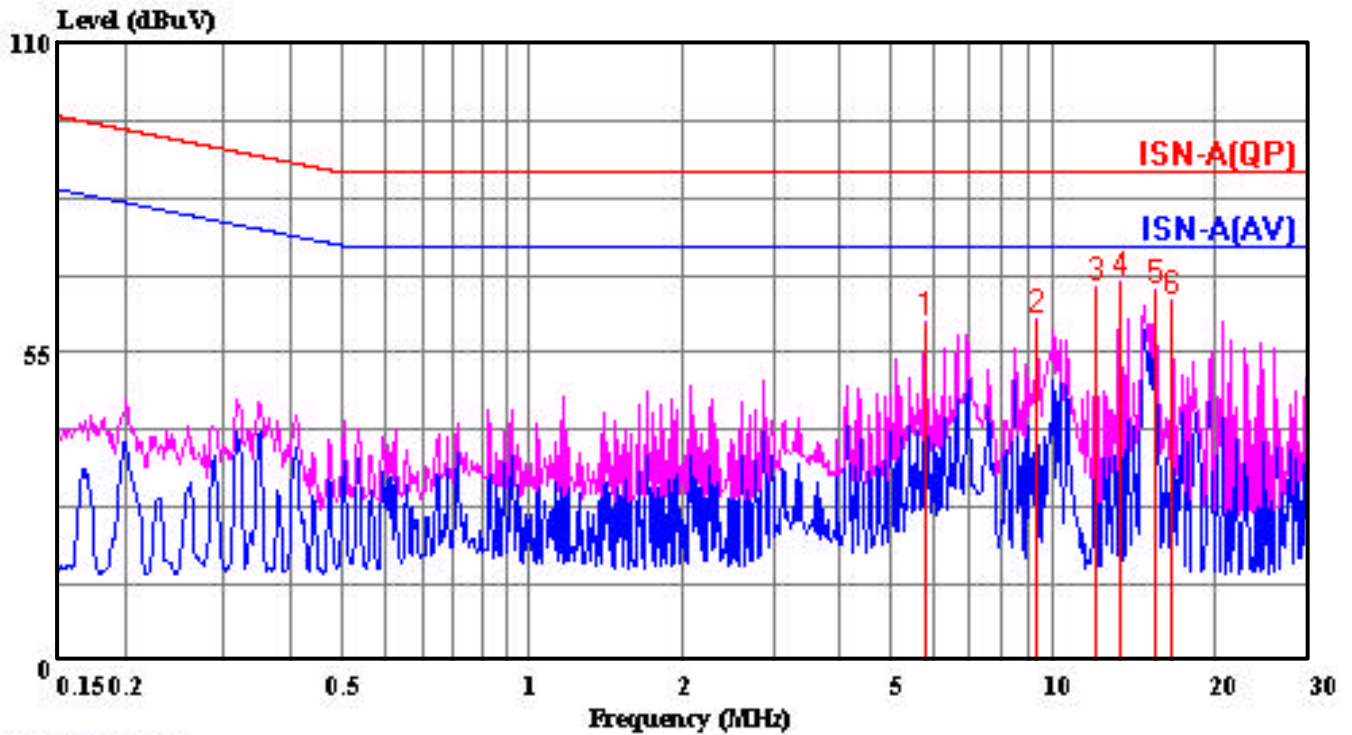

**(Conduction A)**

Trace: 17 16

Ref Trace:

Condition: COMMON  
 Report No. : 50125210  
 Test Engr. : SAM HU  
 Company : AAEON Technology Inc.  
 EUT : HSB-835P A0.1  
 Test Config : EUT / ALL PERIPHERALS  
 Type of Test: EN 55022 CLASS A  
 Mode of Op. : ISN 100Mbps (Worst)

Page: 1

	Read	Limit	Over	
Freq	Level	Factor	Level	Line
MHz	dBuV	dB	dBuV	dBuV
1	50.32	10.26	60.58	87.00
2	50.52	10.22	60.74	87.00
3	56.66	10.22	66.88	87.00
4	57.53	10.23	67.76	87.00
5	55.75	10.24	65.99	87.00
6	53.98	10.25	64.23	87.00

Remark

-26.42 Peak

-26.26 Peak

-20.12 Peak

-19.24 Peak

-21.01 Peak

-22.77 Peak



