

# CE EMC TEST REPORT

for

**1U Rackmount Network Appliance**

**MODEL: xFWS-7520x (x - Where x may be any combination of alphanumeric characters or "-" or blank.)**

Test Report Number:  
T160422D10-E

Issued to:

**AAEON Technology Inc.**

**5F, No.135, Lane 235, Pao Chiao Rd, Hsin-Tien Dist.,  
New Taipei City, Taiwan, R.O.C**

Issued by:

**Compliance Certification Services Inc.**

**Xindian Lab.**

**No.163-1, Jhongsheng Rd., Xindian Dist.,  
New Taipei City, 23151 Taiwan.**

**TEL: 886-2-22170894**

**FAX: 886-2-22171029**

**Issued Date: May 18, 2016**



**Note:** This report shall not be reproduced except in full, without the written approval of Compliance Certification Services Inc. This document may be altered or revised by Compliance Certification Services Inc. personnel only, and shall be noted in the revision section of the document. The client should not use it to claim product endorsement by TAF, A2LA, NVLAP, NIST or any government agencies. The test results in the report only apply to the tested sample.

**Revision History**

Rev.	Issue Date	Revisions	Effect Page	Revised By
00	May 18, 2016	Initial Issue	ALL	Panny Chou

## TABLE OF CONTENTS

<b>1</b>	<b>TEST CERTIFICATION .....</b>	<b>4</b>
<b>2</b>	<b>TEST RESULT SUMMARY .....</b>	<b>5</b>
<b>3</b>	<b>EUT DESCRIPTION .....</b>	<b>6</b>
<b>4</b>	<b>TEST METHODOLOGY .....</b>	<b>7</b>
	4.1. DECISION OF FINAL TEST MODE .....	7
	4.2. EUT SYSTEM OPERATION .....	8
<b>5</b>	<b>SETUP OF EQUIPMENT UNDER TEST .....</b>	<b>8</b>
	5.1. DESCRIPTION OF SUPPORT UNITS .....	8
	5.2. CONFIGURATION OF SYSTEM UNDER TEST .....	9
<b>6</b>	<b>FACILITIES AND ACCREDITATIONS .....</b>	<b>10</b>
	6.1. FACILITIES .....	10
	6.2. ACCREDITATIONS .....	10
	6.3. MEASUREMENT UNCERTAINTY .....	10
<b>7</b>	<b>EMISSION TEST .....</b>	<b>11</b>
	7.1. CONDUCTED EMISSION MEASUREMENT .....	11
	7.2. CONDUCTED EMISSION MEASUREMENT AT TELECOMMUNICATION PORTS .....	16
	7.3. RADIATED EMISSION MEASUREMENT .....	20
	7.4. HARMONICS CURRENT MEASUREMENT .....	28
	7.5. VOLTAGE FLUCTUATION AND FLICKER MEASUREMENT .....	33
<b>8</b>	<b>IMMUNITY TEST .....</b>	<b>35</b>
	8.1. GENERAL DESCRIPTION .....	35
	8.2. GENERAL PERFORMANCE CRITERIA DESCRIPTION .....	36
	8.3. ELECTROSTATIC DISCHARGE (ESD) .....	37
	8.4. RADIATED, RADIO-FREQUENCY, ELECTROMAGNETIC FIELD (RS) .....	44
	8.5. ELECTRICAL FAST TRANSIENT (EFT) .....	47
	8.6. SURGE IMMUNITY TEST .....	50
	8.7. CONDUCTED RADIO FREQUENCY DISTURBANCES (CS) .....	54
	8.8. POWER FREQUENCY MAGNETIC FIELD .....	56
	8.9. VOLTAGE DIPS & VOLTAGE INTERRUPTIONS .....	58
<b>9</b>	<b>PHOTOGRAPHS OF THE TEST CONFIGURATION .....</b>	<b>60</b>
	<b>APPENDIX 1 - PHOTOGRAPHS OF EUT .....</b>	<b>A1-1</b>

# 1 TEST CERTIFICATION

<b>Product:</b>	1U Rackmount Network Appliance	
<b>Model:</b>	xFWS-7520x (x - Where x may be any combination of alphanumeric characters or "-"or blank.)	
<b>Brand:</b>	AAEON	
<b>Applicant:</b>	<b>AAEON Technology Inc.</b> 5F, No.135, Lane 235, Pao Chiao Rd, Hsin-Tien Dist., New Taipei City, Taiwan, R.O.C	
<b>Manufacturer:</b>	<b>AAEON Technology Inc.</b> 5F, No.135, Lane 235, Pao Chiao Rd, Hsin-Tien Dist., New Taipei City, Taiwan, R.O.C	
<b>Tested:</b>	April 23, 2016 ~ May 16, 2016	
<b>Applicable Standards:</b>	<b>EN 55022: 2010 / AC: 2011, Class A</b> <b>CISPR 22: 2008 (Ed 6.0)</b> <b>EN 61000-3-2: 2014</b> <b>EN 61000-3-3: 2013</b>	<b>EN 55024: 2010</b> IEC 61000-4-2: 2008 IEC 61000-4-3: 2006 + A1: 2007 + A2: 2010 IEC 61000-4-4: 2012 IEC 61000-4-5: 2014 IEC 61000-4-6: 2013 IEC 61000-4-8: 2009 IEC 61000-4-11: 2004

Deviation from Applicable Standard
None

The above equipment was tested by Compliance Certification Services Inc. for compliance with the requirements of technical standards specified above under the EMC Directive 2014/30/EU. The results of testing in this report apply only to the product/system, which was tested. Other similar equipment will not necessarily produce the same results due to production tolerance and measurement uncertainties.

**Approved by:**

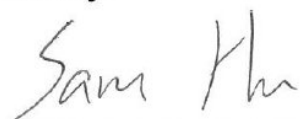

Sam Hu  
Assistant Manager

**Reviewed by:**

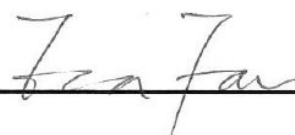

Eva Fan  
Supervisor of report document dept.

## 2 TEST RESULT SUMMARY

<b>EMISSION</b>			
<b>Standard</b>	<b>Item</b>	<b>Result</b>	<b>Remarks</b>
EN 55022: 2010 / AC: 2011 CISPR 22: 2008 (Ed 6.0)	Conducted (Power Port)	PASS	Meet Class A limit
	Conducted (Telecom port)	PASS	Meet Class A limit
	Radiated	PASS	Meet Class A limit
EN 61000-3-2: 2014	Harmonic current emissions	PASS	Meet Class A limit
EN 61000-3-3: 2013	Voltage fluctuations & flicker	PASS	Meets the requirements

<b>IMMUNITY [ EN 55024 (2010) ]</b>			
<b>Standard</b>	<b>Item</b>	<b>Result</b>	<b>Remarks</b>
IEC 61000-4-2: 2008	ESD	PASS	Meets the requirements of Performance Criterion A
IEC 61000-4-3: 2006 + A1: 2007 + A2: 2010	RS	PASS	Meets the requirements of Performance Criterion A
IEC 61000-4-4: 2012	EFT	PASS	Meets the requirements of Performance Criterion A
IEC 61000-4-5: 2014	Surge	PASS	Meets the requirements of Performance Criterion A
IEC 61000-4-6: 2013	CS	PASS	Meets the requirements of Performance Criterion A
IEC 61000-4-8: 2009	PFMF	N/A	Please see the page 57
IEC 61000-4-11: 2004	Voltage dips & voltage variations	PASS	Meets the requirements of <b>Voltage Dips:</b> 1) >95% reduction Performance Criterion A 2) 30% reduction Performance Criterion A <b>Voltage Interruptions:</b> 1) >95% reduction Performance Criterion C

- Note:**
1. The statements of test result on the above are decided by the request of test standard only; the measurement uncertainties are not factored into this compliance determination.
  2. The information of measurement uncertainty is available upon the customer's request.

### 3 EUT DESCRIPTION

<b>Product</b>	1U Rackmount Network Appliance
<b>Brand Name</b>	AAEON
<b>Model</b>	xFWS-7520x (x - Where x may be any combination of alphanumeric characters or "-"or blank.)
<b>Applicant</b>	AAEON Technology Inc.
<b>Housing material</b>	Metal case
<b>Identify Number</b>	T160422D10
<b>Received Date</b>	April 22, 2016
<b>EUT Power Rating</b>	100-240VAC
<b>AC Power During Test</b>	230VAC / 50Hz

#### Model Differences

Model	Difference	Tested (Check)
FWS-7520W3-H25-A10-000	Original	<input checked="" type="checkbox"/>
xFWS-7520x	1. For marketing purpose only 2. x - Where x may be any combination of alphanumeric characters or "-"or blank.	<input type="checkbox"/>

#### I/O PORT

I/O PORT TYPES	Q'TY	TESTED WITH
1. VGA Port	1	1
2. USB Port	2	2
3. LAN Port	9	9
4. IPMI Port	1	1
5. Console Port	1	1
6. Fiber Port	8	8

**Note:** Client consigns only one model sample to test (Model Number: FWS-7520W3-H25-A10-000).

## 4 TEST METHODOLOGY

### 4.1. DECISION OF FINAL TEST MODE

The EUT was tested together with the below additional components, and a configuration, which produced the worst emission levels, was selected and recorded in this report.

The test configuration/ modes are as the following:

**Conduction Modes (Power port):**

No.	Power Supply	Operate State	
1	FSP / FSP180-50LG	VGA Mode	1920X1080, VF=60Hz
2	ETASIS / EFAP-S250	VGA Mode	1920X1080, VF=60Hz

**Conduction Modes (Telecom port):**

No.	Power Supply	Operate State		
1	FSP / FSP180-50LG	LAN Mode		10Mbps
2				100Mbps
3				1Gbps
4		IPMI Mode		10Mbps
5				100Mbps
6				1Gbps
7		LAN Card Mode	LAN 1	1Gbps
8				10Mbps
9			LAN 8	100Mbps
10				1Gbps
11	ETASIS / EFAP-S250	LAN Mode		10Mbps
12				100Mbps
13				1Gbps
14		IPMI Mode		10Mbps
15				100Mbps
16				1Gbps
17		LAN Card Mode	LAN 1	1Gbps
18				10Mbps
19			LAN 8	100Mbps
20				1Gbps

**Radiation Mode:**

No.	Power Supply	Operate State	
1	FSP / FSP180-50LG	VGA Mode	1920X1080, VF=60Hz
			1920X1080, VF=60Hz / 1-6GHz
2	ETASIS / EFAP-S250	VGA Mode	1920X1080, VF=60Hz

**Worst:**

**Conduction (Power port):** Mode 2

**Conduction (Telecom port):** Mode 5

**Radiation:** Mode 1

## 4.2. EUT SYSTEM OPERATION

1. All peripherals connect EUT.
2. Press the start menu, select executive and type ping 192.168.1.2 –t (EUT), ping 192.168.2.2 –t (EUT), ping 192.168.3.2 –t (EUT), ping 192.168.4.2 –t (EUT), ping 192.168.5.2 –t (EUT), ping 192.168.6.2 –t (EUT), ping 192.168.7.2 –t (EUT), ping 192.168.8.2 –t (EUT), ping 192.168.9.2 –t (EUT), ping 192.168.10.2 –t (EUT), ping 192.168.1.1 –t (Server PC), ping 192.168.2.1 –t (Server PC), ping 192.168.3.1 –t (Server PC), ping 192.168.4.1 –t (Server PC), ping 192.168.5.1 –t (Server PC), ping 192.168.6.1 –t (Server PC), ping 192.168.7.1 –t (Server PC), ping 192.168.8.1 –t (Server PC), ping 192.168.9.1 –t (Server PC), ping 192.168.10.1 –t (Server PC).

**Note:** Test program is self-repeating throughout the test.

## 5 SETUP OF EQUIPMENT UNDER TEST

### 5.1. DESCRIPTION OF SUPPORT UNITS

The EUT has been tested as an independent unit together with other necessary accessories or support units. The following support units or accessories were used to form a representative test configuration during the tests.

#### EUT Devices:

No.	Equipment	Model No.	Brand Name
1	CPU (IntelR XeonR Processor / 2.0GHz)	D-1548	Intel
2	Memory (128GB)	M88DDR4RCD01	Micron
3	Power Supply	FSP180-50LG	FSP
		EFAP-S250	ETASIS
4	HDD (500GB)	MQ01ABF050	Toshiba

#### Peripherals Devices:

No.	Equipment	Model No.	Serial No.	FCC ID / BSMI ID	Brand Name	Data Cable	Power Cord
1	Console Cable	N/A	N/A	N/A	N/A	Shielded, 1.8m	N/A
2-5	Fiber Loop	N/A	N/A	N/A	N/A	Shielded, 2.5m	N/A
6	USB Mouse	M-U0026	810-002181	DOC BSMI: T41126	Logitech	Shielded, 1.8m	N/A
7	USB Keyboard	SK-8115	N/A	DOC BSMI: T3A002	DELL	Shielded, 1.8m	N/A
8-15	Server PC	T3500	N/A	BSMI ID: R33002	DELL	Unshielded, 20m	Unshielded, 1.8m
16-17	Server PC	T3610	N/A	BSMI ID: R33002	DELL	Unshielded, 20m	Unshielded, 1.8m
18	Monitor	P2314Ht	N/A	DOC BSMI: R33002	DELL	Shielded, 1.8m with two cores	Unshielded, 1.8m

**Note:**

- 1) All the equipment/cables were placed in the worst-case configuration to maximize the emission during the test.
- 2) Grounding was established in accordance with the manufacturer’s requirements and conditions for the intended use.



## 5.2. CONFIGURATION OF SYSTEM UNDER TEST

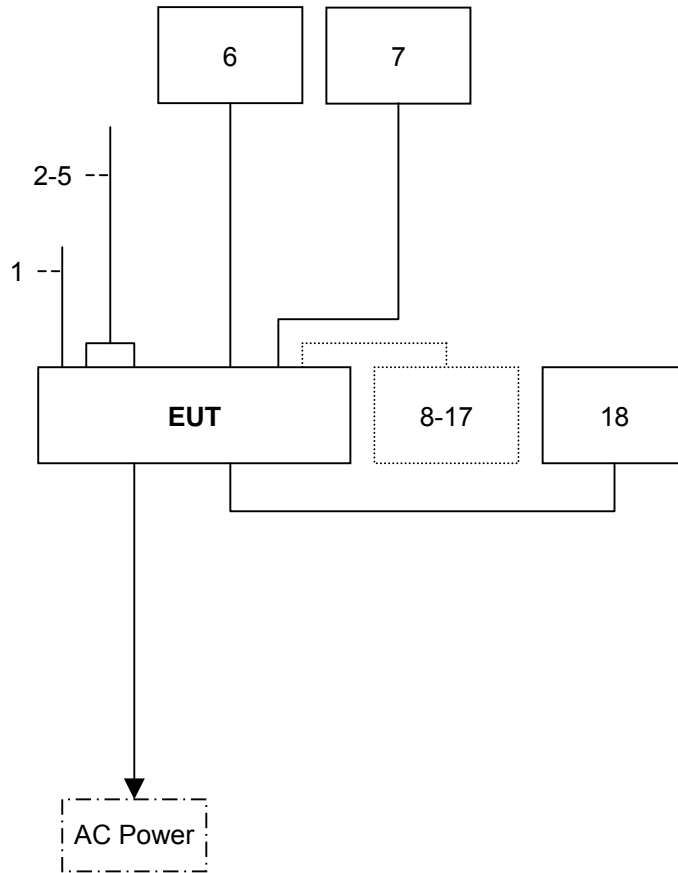

## 6 FACILITIES AND ACCREDITATIONS

### 6.1. FACILITIES

All measurement facilities used to collect the measurement data are located at CCSrf Taiwan Xindian Lab. at No.163-1, Jhongsheng Rd., Xindian Dist., New Taipei City, 23151 Taiwan.

The sites are constructed in conformance with the requirements of ANSI C63.4 and CISPR Publication 22. All receiving equipment conforms to CISPR 16-1-1, CISPR 16-1-2, CISPR 16-1-3, CISPR 16-1-4 and CISPR 16-1-5.

### 6.2. ACCREDITATIONS

Our laboratories are accredited and approved by the following accreditation body according to ISO/IEC 17025.

Taiwan	TAF
USA	A2LA

The measuring facility of laboratories has been authorized or registered by the following approval agencies.

Canada	Industry Canada
Norway	Nemko
Japan	VCCI
Taiwan	BSMI
USA	FCC

Copies of granted accreditation certificates are available for downloading from our web site, <http://www.ccsrf.com>

### 6.3. MEASUREMENT UNCERTAINTY

Where relevant, the following measurement uncertainty levels have been estimated for tests performed on the EUT as specified in CISPR 16-4-2:

Measurement	Frequency	Uncertainty
Conducted emissions (Power port)	0.15MHz ~ 30MHz	± 1.59
Conducted emissions (Telecom port)	0.15MHz ~ 30MHz	± 2.91
Radiated emissions	30MHz ~ 1000MHz	± 4.02
	1000MHz ~ 6000MHz	± 4.74

This uncertainty represents an expanded uncertainty expressed at approximately the 95% confidence level using a coverage factor of k=2.

Consistent with industry standard (e.g. CISPR 22: 2005, clause 11, Measurement Uncertainty) determining compliance with the limits shall be base on the results of the compliance measurement. Consequently the measure emissions being less than the maximum allowed emission result in this be a compliant test or passing test.

The acceptable measurement uncertainty value without requiring revision of the compliance statement is base on conducted and radiated emissions being less than  $U_{CISPR}$  which is 3.6dB and 5.2dB respectively. CCS values (called  $U_{Lab}$  in CISPR 16-4-2) is less than  $U_{CISPR}$  as shown in the table above. Therefore, MU need not be considered for compliance.

## 7 EMISSION TEST

### 7.1. CONDUCTED EMISSION MEASUREMENT

#### 7.1.1. LIMITS

FREQUENCY (MHz)	Class A (dBuV)		Class B (dBuV)	
	Quasi-peak	Average	Quasi-peak	Average
0.15 - 0.5	79	66	66 - 56	56 - 46
0.50 - 5.0	73	60	56	46
5.0 - 30.0	73	60	60	50

**NOTE:**

- (1) The lower limit shall apply at the transition frequencies.
- (2) The limit decreases in line with the logarithm of the frequency in the range of 0.15 to 0.50 MHz.
- (3) All emanations from a class A/B digital device or system, including any network of conductors and apparatus connected thereto, shall not exceed the level of field strengths specified above.

#### 7.1.2. TEST INSTRUMENTS

Conducted Emission room # A				
Name of Equipment	Manufacturer	Model	Serial Number	Calibration Due
BNC CABLE	EMCI	CFD300-NL	BNC#A8	05/19/2016
EMI Test Receiver	R&S	ESCI	101201	08/21/2016
LISN	Schwarzbeck	NNLK 8129	8129-286	10/27/2016
LISN(EUT)	Schwarzbeck	NSLK 8127	8127527	08/23/2016
Pulse Limiter	R&S	ESH3Z2	C3010026-2	08/23/2016
Thermo-Hygro Meter	Wisewind	201A	No. 02	05/02/2017
Test S/W	EZ-EMC			

- NOTE:** 1. The calibration interval of the above test instruments is 12 months and the calibrations are traceable to NML/ROC and NIST/USA.  
 2. N.C.R = No Calibration Request.

**7.1.3. TEST PROCEDURES** (please refer to measurement standard or CCS SOP PA-031)**Procedure of Preliminary Test**

- The EUT and Support equipment, if needed, was set up as per the test configuration to simulate typical usage per the user's manual. When the EUT is a tabletop system, a wooden table with a height of 0.8 meters is used and is placed on the ground plane as per EN 55022 (see Test Facility for the dimensions of the ground plane used). When the EUT is a floor standing equipment, it is placed on the ground plane, which has a 15 cm non-conductive covering to insulate the EUT from the ground plane.
- All I/O cables were positioned to simulate typical actual usage as per EN 55022.
- The test equipment EUT installed received AC main power, through a Line Impedance Stabilization Network (LISN), which supplied power source and was grounded to the ground plane.
- All support equipment power received from a second LISN.
- The EUT test program was started. Emissions were measured on each current carrying line of the EUT using an EMI Test Receiver connected to the LISN powering the EUT.
- The Receiver scanned from 150kHz to 30MHz for emissions in each of the test modes.
- During the above scans, the emissions were maximized by cable manipulation.
- The test mode(s) described in Item 4.1 were scanned during the preliminary test.
- After the preliminary scan, we found the test mode described in Item 4.1 producing the highest emission level.
- The EUT configuration and cable configuration of the above highest emission levels were recorded for reference of the final test.

**Procedure of Final Test**

- EUT and support equipment were set up on the test bench as per the configuration with highest emission level in the preliminary test.
- A scan was taken on both power lines, Line 1 and Line 2, recording at least the six highest emissions. Emission frequency and amplitude were recorded into a computer in which correction factors were used to calculate the emission level and compare reading to the applicable limit.
- The test data of the worst-case condition(s) was recorded.

**7.1.4. TEST SETUP**

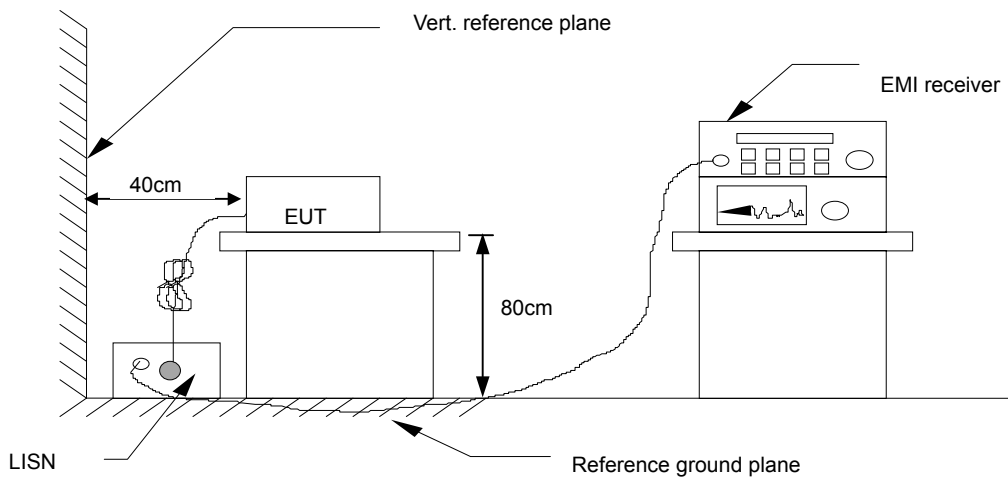

- For the actual test configuration, please refer to the related item – Photographs of the Test Configuration.

**7.1.5. DATA SAMPLE**

Freq. (MHz)	Reading (dBuV)	Factor (dB)	Result (dBuV)	Limit (dBuV)	Margin (dB)	Detector (P/Q/A)	Line (L1/L2)
x.xx	42.95	0.55	43.50	73	-29.50	Q	L1

- Freq. = Emission frequency in MHz
- Reading = Uncorrected Analyzer/Receiver reading
- Factor = Insertion loss of LISN + Cable Loss + Pulse Limit
- Result = Reading + Factor
- Limit = Limit stated in standard
- Margin = Reading in reference to limit
- P = Peak Reading
- Q = Quasi-peak Reading
- A = Average Reading
- L1 = Hot side
- L2 = Neutral side

**Calculation Formula**

Margin (dB) = Result (dBuV) – Limit (dBuV)

**7.1.6. TEST RESULTS**

<b>Model No.</b>	FWS-7520W3-H25-A10-000	<b>6dB Bandwidth</b>	9 kHz
<b>Environmental Conditions</b>	25°C, 58% RH	<b>Test Mode</b>	Mode 2
<b>Tested by</b>	Stanley Cheng	<b>Phase</b>	L1
<b>Standard</b>	EN 55022 CLASS A		

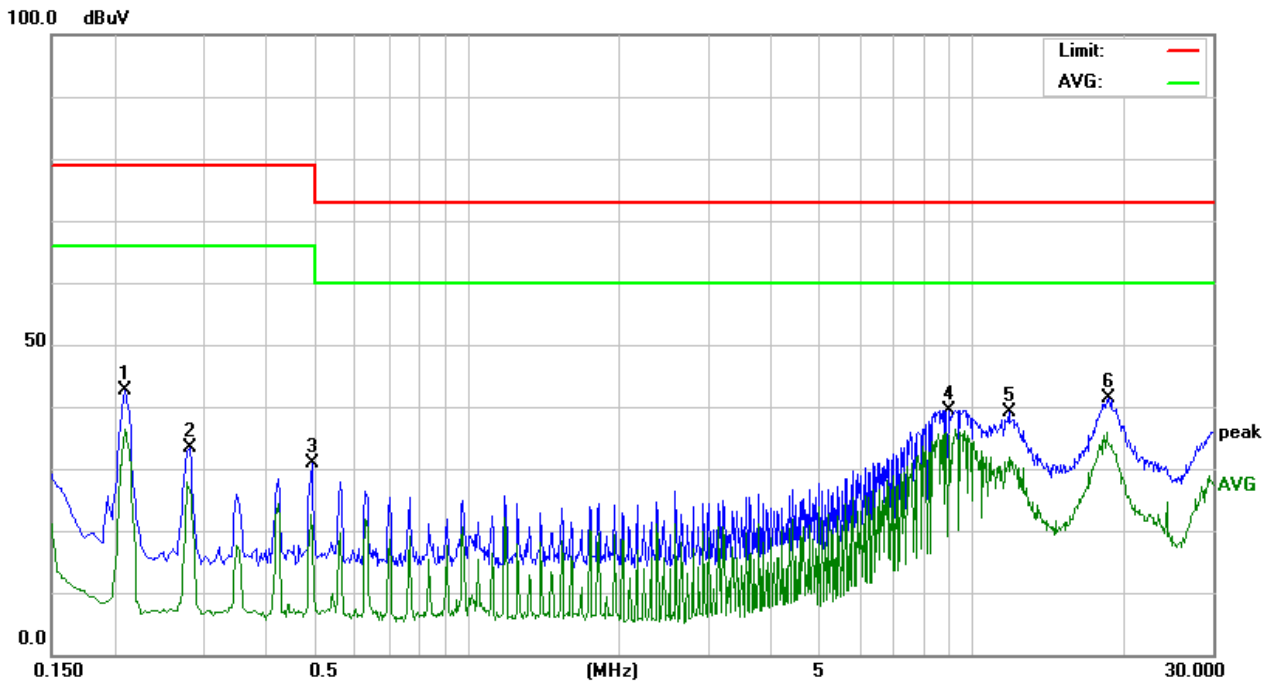

<b>Conducted Emission Readings</b>							
<b>Frequency Range Investigated</b>				<b>150 kHz to 30 MHz</b>			
Freq. (MHz)	Reading (dBuV)	Factor (dB)	Result (dBuV)	Limit (dBuV)	Margin (dB)	Detector (P/Q/A)	Line (L1/L2)
<b>0.2100</b>	<b>32.49</b>	<b>10.07</b>	<b>42.56</b>	<b>79.00</b>	<b>-36.44</b>	<b>P</b>	<b>L1</b>
<b>0.2819</b>	<b>23.34</b>	<b>10.08</b>	<b>33.42</b>	<b>79.00</b>	<b>-45.58</b>	<b>P</b>	<b>L1</b>
<b>0.4940</b>	<b>20.72</b>	<b>10.09</b>	<b>30.81</b>	<b>79.00</b>	<b>-48.19</b>	<b>P</b>	<b>L1</b>
<b>8.9700</b>	<b>28.86</b>	<b>10.53</b>	<b>39.39</b>	<b>73.00</b>	<b>-33.61</b>	<b>P</b>	<b>L1</b>
<b>11.8500</b>	<b>28.45</b>	<b>10.66</b>	<b>39.11</b>	<b>73.00</b>	<b>-33.89</b>	<b>P</b>	<b>L1</b>
<b>18.6900</b>	<b>30.46</b>	<b>10.98</b>	<b>41.44</b>	<b>73.00</b>	<b>-31.56</b>	<b>P</b>	<b>L1</b>

**Note:** L1 = Line One (Live Line) / L2 = Line Two (Neutral Line).

<b>Model No.</b>	FWS-7520W3-H25-A10-000	<b>6dB Bandwidth</b>	9 kHz
<b>Environmental Conditions</b>	25°C, 58% RH	<b>Test Mode</b>	Mode 2
<b>Tested by</b>	Stanley Cheng	<b>Phase</b>	L2
<b>Standard</b>	EN 55022 CLASS A		

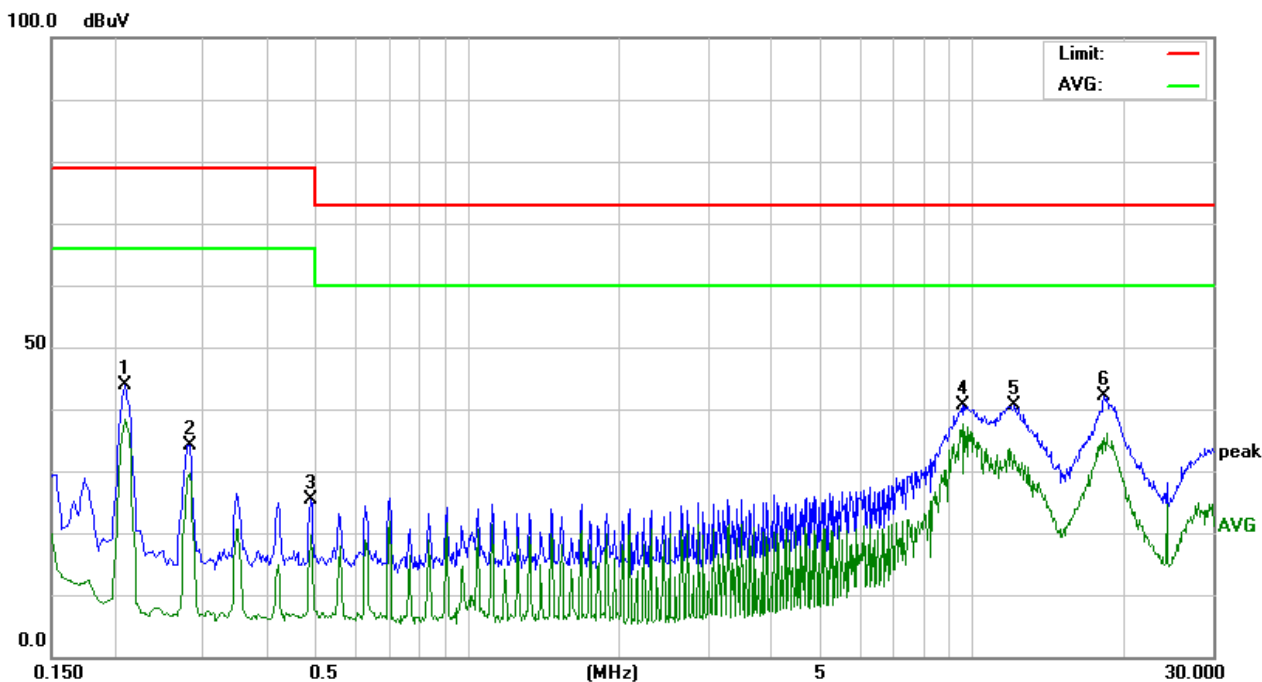

Conducted Emission Readings							
Frequency Range Investigated				150 kHz to 30 MHz			
Freq. (MHz)	Reading (dBuV)	Factor (dB)	Result (dBuV)	Limit (dBuV)	Margin (dB)	Detector (P/Q/A)	Line (L1/L2)
0.2100	33.79	10.07	43.86	79.00	-35.14	P	L2
0.2819	24.16	10.08	34.24	79.00	-44.76	P	L2
0.4900	15.28	10.08	25.36	79.00	-53.64	P	L2
9.6020	29.99	10.55	40.54	73.00	-32.46	P	L2
12.1860	29.89	10.66	40.55	73.00	-32.45	P	L2
18.2979	31.28	10.96	42.24	73.00	-30.76	P	L2

**Note:** L1 = Line One (Live Line) / L2 = Line Two (Neutral Line).

## 7.2. CONDUCTED EMISSION MEASUREMENT AT TELECOMMUNICATION PORTS

### 7.2.1. LIMITS

For Class A Equipment

FREQUENCY (MHz)	Voltage Limit (dBuV)		Current Limit (dBuA)	
	Quasi-peak	Average	Quasi-peak	Average
0.15 ~ 0.5	97 ~ 87	84 ~ 74	53 ~ 43	40 ~ 30
0.5 ~ 30.0	87	74	43	30

**NOTE:** The limits decrease linearly with the logarithm of the frequency in the range 0.15 MHz to 0.5 MHz.

For Class B Equipment

FREQUENCY (MHz)	Voltage Limit (dBuV)		Current Limit (dBuA)	
	Quasi-peak	Average	Quasi-peak	Average
0.15 - 0.5	84 ~ 74	74 ~ 64	40 ~ 30	30 ~ 20
0.5 - 30.0	74	64	30	20

**NOTE:** The limits decrease linearly with the logarithm of the frequency in the range 0.15 MHz to 0.5 MHz.

### 7.2.2. TEST INSTRUMENTS

Conducted Emission room # A				
Name of Equipment	Manufacturer	Model	Serial Number	Calibration Due
BNC CABLE	EMCI	CFD300-NL	BNC#A8	05/19/2016
EMI Test Receiver	R&S	ESCI	101201	08/21/2016
ISN	Teseq	ISN T800	29449	08/24/2016
LISN	Schwarzbeck	NNLK 8129	8129-286	10/27/2016
LISN(EUT)	Schwarzbeck	NSLK 8127	8127527	08/23/2016
Pulse Limiter	R&S	ESH3Z2	C3010026-2	08/23/2016
Thermo-Hygro Meter	Wisewind	201A	No. 02	05/02/2017
Test S/W	EZ-EMC			

**NOTE:** 1. The calibration interval of the above test instruments is 12 months and the calibrations are traceable to NML/ROC and NIST/USA.  
 2. N.C.R = No Calibration Request.



**7.2.3. TEST PROCEDURE** (please refer to measurement standard or CCS SOP PA-031)

- Selecting ISN for unscreened cable or a current probe for screened cable to take measurement.
- The port of the EUT was connected to the remote side support equipment through the ISN/Current Probe and communication in normal condition.
- Making a overall range scan by using the test receiver controlled by controller and record at least six highest emissions for showing in the test report.
- Emission frequency and amplitude were recorded into a computer in which correction factors were used to calculate the emission level and compare reading to the applicable limit.
- In case of measuring on the screened cable, the current limit shall be applied; otherwise the voltage limit should be applied.
- The following test modes was scanned during the preliminary test:

**Modes:**

No.	Power Supply	Operate State		
1	FSP / FSP180-50LG	LAN Mode		10Mbps
2				100Mbps
3				1Gbps
4		IPMI Mode		10Mbps
5				100Mbps
6				1Gbps
7		LAN Card Mode	LAN 1	1Gbps
8			LAN 8	10Mbps
9				100Mbps
10				1Gbps
11	ETASIS / EFAP-S250	LAN Mode		10Mbps
12				100Mbps
13				1Gbps
14		IPMI Mode		10Mbps
15				100Mbps
16				1Gbps
17		LAN Card Mode	LAN 1	1Gbps
18			LAN 8	10Mbps
19				100Mbps
20				1Gbps

- After the preliminary scan, we found the following test mode(s) producing the highest emission level and test data of the worst case was recorded.

**Mode: 5**

**7.2.4. TEST SETUP**

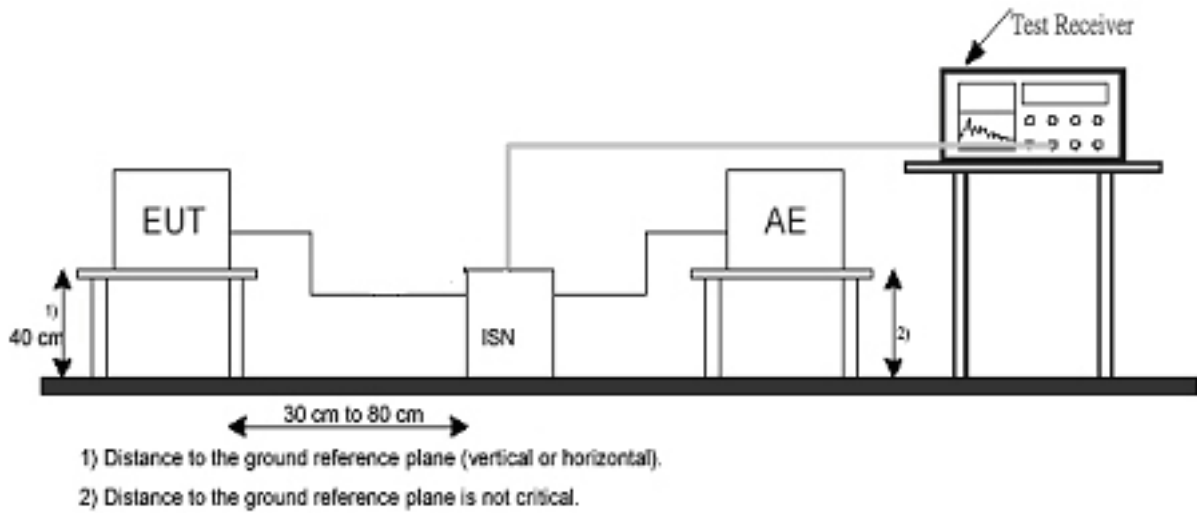

- For the actual test configuration, please refer to the related item – Photographs of the Test Configuration.

**7.2.5. DATA SAMPLE**

Freq. (MHz)	Reading (dBuV)	Factor (dB)	Result (dBuV)	Limit (dBuV)	Margin (dB)	Detector (P/Q/A)
x.xx	62.95	0.55	63.50	87	-23.50	Q

- Freq. = Emission frequency in MHz
- Reading = Uncorrected Analyzer/Receiver reading
- Factor = Insertion loss of LISN + Cable Loss + Pulse Limit
- Result = Reading + Factor
- Limit = Limit stated in standard
- Margin = Reading in reference to limit
- P = Peak Reading
- Q = Quasi-peak Reading
- A = Average Reading

**Calculation Formula**

Margin (dB) = Result (dBuV) – Limit (dBuV)

7.2.6. TEST RESULTS

<b>Model No.</b>	FWS-7520W3-H25-A10-000	<b>6dB Bandwidth</b>	9 kHz
<b>Environmental Conditions</b>	20°C, 58% RH	<b>Test Mode</b>	Mode 5
<b>Tested by</b>	David Cheng	<b>Standard</b>	EN 55022 CLASS A

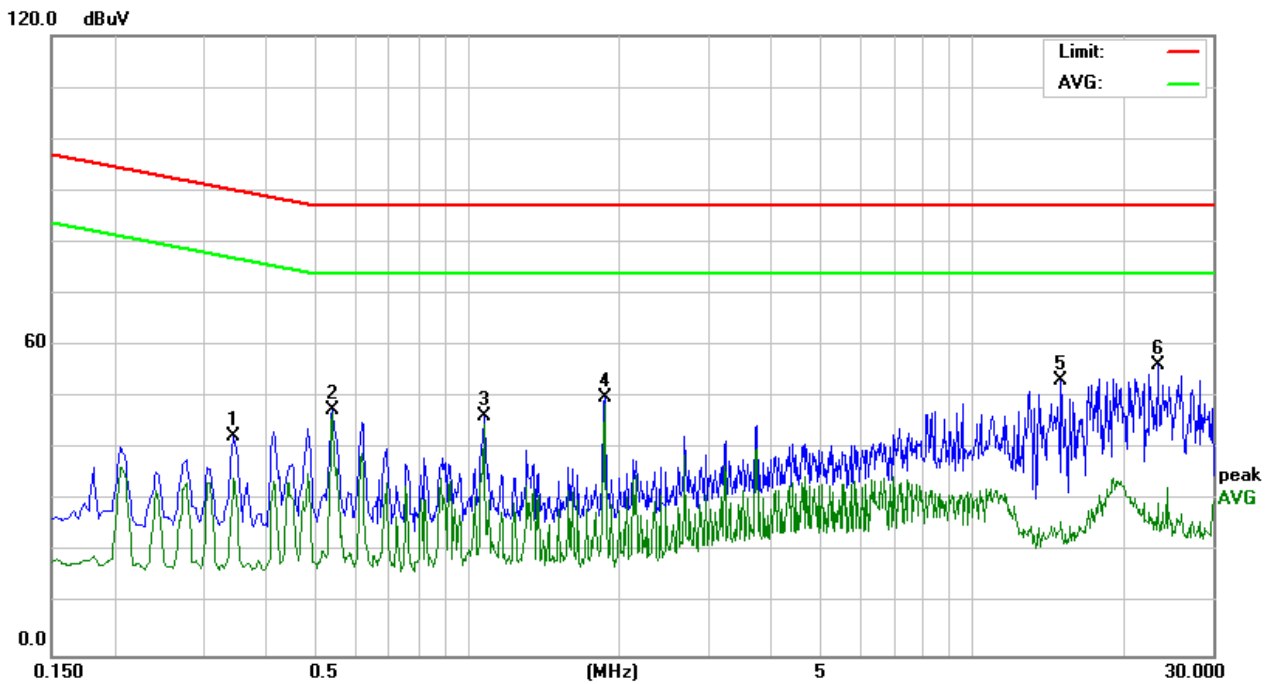

Conducted Emission Readings						
Frequency Range Investigated				150 kHz to 30 MHz		
Freq. (MHz)	Reading (dBuV)	Factor (dB)	Result (dBuV)	Limit (dBuV)	Margin (dB)	Detector (P/Q/A)
0.3460	22.68	19.88	42.56	90.06	-47.50	P
0.5420	27.69	19.78	47.47	87.00	-39.53	P
1.0820	26.68	19.71	46.39	87.00	-40.61	P
1.8700	30.23	19.72	49.95	87.00	-37.05	P
15.0220	33.33	19.89	53.22	87.00	-33.78	P
23.3260	36.04	20.12	56.16	87.00	-30.84	P

### 7.3. RADIATED EMISSION MEASUREMENT

#### 7.3.1. LIMITS

**Below 1GHz**

FREQUENCY (MHz)	dBuV/m (At 10m)	
	Class A	Class B
30 ~ 230	40	30
230 ~ 1000	47	37

**Above 1GHz**

Frequency (MHz)	Class A (dBuV/m) (At 3m)		Class B (dBuV/m) (At 3m)	
	Average	Peak	Average	Peak
1000 ~ 3000	56	76	50	70
3000 ~ 6000	60	80	54	74

**NOTE:** The lower limit shall apply at the transition frequencies.

According to EN 55022: 2010 / AC: 2011 clause 6.2, the measurement frequency range shown in the following table:

Highest frequency generated or used within the EUT or on which the EUT operates or tunes (MHz)	Upper frequency of measurement range (MHz)
Less than 108	1000
108-500	2000
500-1000	5000
Above 1000	5 times of the highest frequency or 6GHz, whichever is less

**7.3.2. TEST INSTRUMENTS**

Open Area Test Site # E				
Name of Equipment	Manufacturer	Model	Serial Number	Calibration Due
Bilog Antenna	ETC	MCTD 2756	BL11M01007	08/03/2016
Cable	EMCI	8Dr	N-Type#E1	03/28/2017
Cable	EMCI	8Dr	N-Type#E2	03/28/2017
EMI Test Receiver	R&S	ESCI	101299	11/24/2016
Pre-Amplifier	HP	8447D	2944A08282	03/28/2017
Thermo-Hygro Meter	Wisewind	N/A	812	07/13/2016
Test S/W	EZ-EMC			
Above 1GHz Used				
Horn Antenna	ETS	3117	139062	10/21/2016
K-Type Cable x 1m (1-40GHz)	Huber+Suhner	SUCOFLEX 102	33106/2	12/15/2016
Microflex Cable x 7m (1-18GHz)	Rosnol	A1K50-EW0630-A1k5 0-7M	151126-1	12/20/2016
Pre-Amplifier	HP	8449B	3008A01266	12/13/2016
Signal Analyzer	Agilent	N9010A	MY53440125	12/13/2016
Thermo-Hygro Meter	Wisewind	201A	No. 02	05/10/2016
Test S/W	EZ-EMC			

**NOTE:** 1. The calibration interval of the above test instruments is 12 months and the calibrations are traceable to NML/ROC and NIST/USA.  
 2. N.C.R = No Calibration Request.

**7.3.3. TEST PROCEDURE** (please refer to measurement standard or CCS SOP PA-031)**Procedure of Preliminary Test**

- The equipment was set up as per the test configuration to simulate typical usage per the user's manual. When the EUT is a tabletop system, a wooden turntable with a height of 0.8 meters is used which is placed on the ground plane. When the EUT is a floor standing equipment, it is placed on the ground plane which has a 15 cm non-conductive covering to insulate the EUT from the ground plane.
- Support equipment, if needed, was placed as per EN 55022.
- All I/O cables were positioned to simulate typical usage as per EN 55022.
- The EUT received AC power source from the outlet socket under the turntable. All support equipment power received from another socket under the turntable.
- The antenna was placed at 3 or 10 meter away from the EUT as stated in EN 55022. The antenna connected to the Spectrum Analyzer via a cable and at times a pre-amplifier would be used.
- The Analyzer / Receiver quickly scanned from 30MHz to 6000MHz. The EUT test program was started. Emissions were scanned and measured rotating the EUT to 360 degrees and positioning the antenna 1 to 4 meters above the ground plane, in both the vertical and the horizontal polarization, to maximize the emission reading level.
- The test mode(s) described in Item 4.1 were scanned during the preliminary test:
- After the preliminary scan, we found the test mode described in Item 4.1 producing the highest emission level.
- The EUT and cable configuration, antenna position, polarization and turntable position of the above highest emission level were recorded for the final test.

**Procedure of Final Test**

- EUT and support equipment were set up on the turntable as per the configuration with highest emission level in the preliminary test.
- The Analyzer / Receiver scanned from 30MHz to 6000MHz. Emissions were scanned and measured rotating the EUT to 360 degrees, varying cable placement and positioning the antenna 1 to 4 meters above the ground plane, in both the vertical and the horizontal polarization, to maximize the emission reading level.
- Recorded at least the six highest emissions. Emission frequency, amplitude, antenna position, polarization and turntable position were recorded into a computer in which correction factors were used to calculate the emission level and compare reading to the applicable limit. Below 1GHz the Q.P. reading and above 1GHz the Peak and Average reading are presented.
- The test data of the worst-case condition(s) was recorded.

**7.3.4. TEST SETUP**

**Below 1GHz**

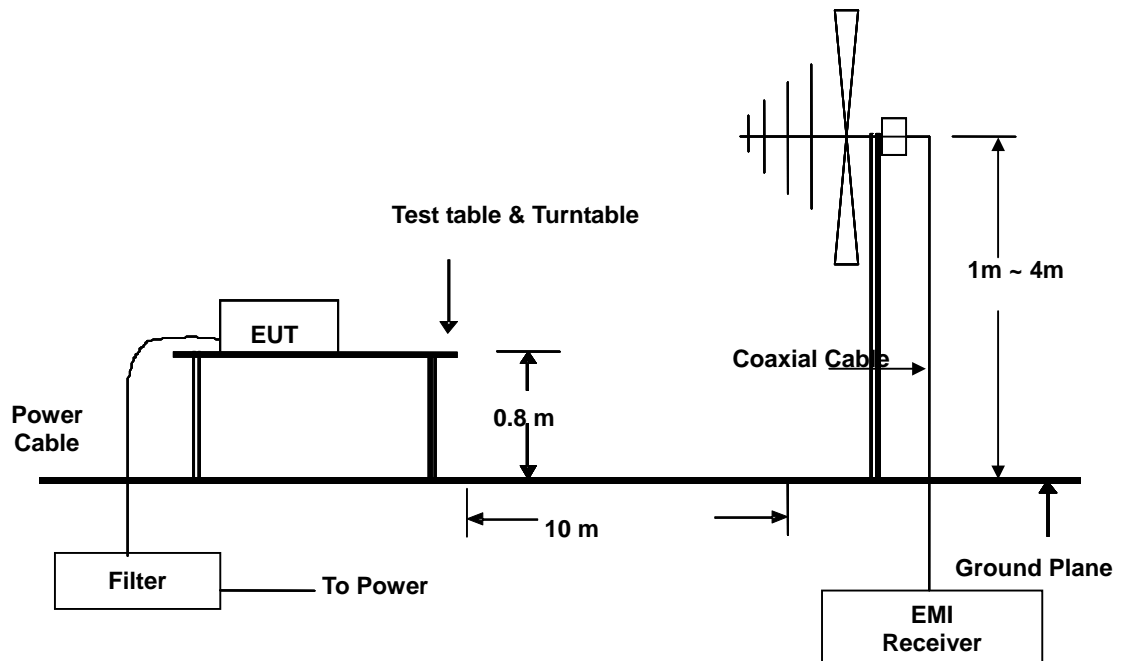

**Above 1GHz**

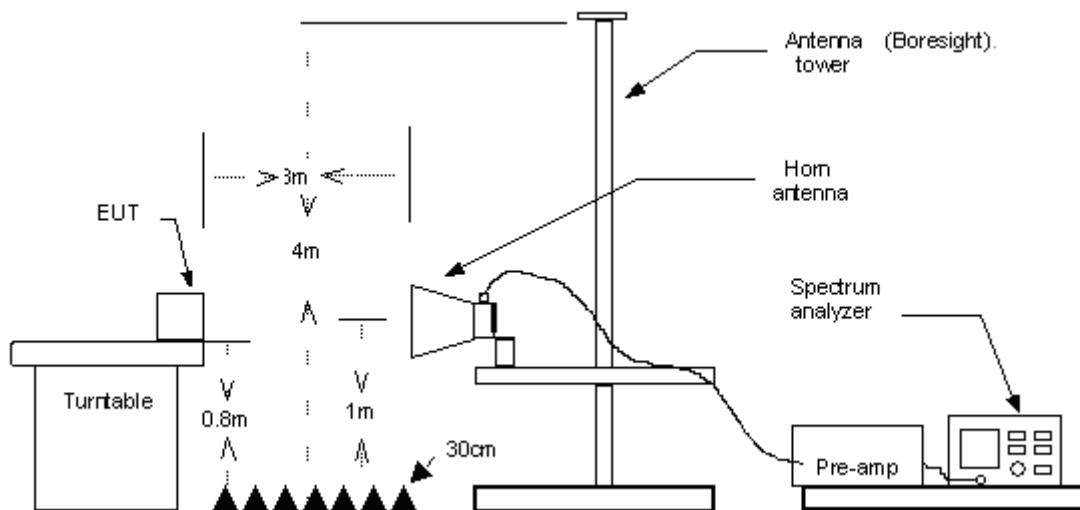

- For the actual test configuration, please refer to the related item – Photographs of the Test Configuration.

**7.3.5. DATA SAMPLE**

**Below 1GHz**

Freq. (MHz)	Reading (dBUV)	Factor (dB/m)	Result (dBUV/m)	Limit (dBUV/m)	Margin (dB)	Detector (P/Q)	Pol. (H/V)
x.xx	14.0	12.2	26.2	40	-13.8	Q	H

**Above 1GHz**

Freq. (MHz)	Reading (dBUV)	Factor (dB/m)	Result (dBUV/m)	Limit (dBUV/m)	Margin (dB)	Detector (P/A)	Pol. (H/V)
x.xx	42.95	0.55	43.50	60	-16.50	A	H

- Freq. = Emission frequency in MHz
- Reading = Uncorrected Analyzer/Receiver reading
- Factor = Antenna Factor + Cable Loss - Amplifier Gain
- Result = Reading + Factor
- Limit = Limit stated in standard
- Margin = Reading in reference to limit
- P = Peak Reading
- Q = Quasi-peak Reading
- A = Average Reading
- H = Antenna Polarization: Horizontal
- V = Antenna Polarization: Vertical

**Calculation Formula**

Margin (dB) = Result (dBUV/m) – Limit (dBUV/m)



7.3.6. TEST RESULTS

Below 1GHz

<b>Model No.</b>	FWS-7520W3-H25-A10-000	<b>Test Mode</b>	Mode 1
<b>Environmental Conditions</b>	22°C, 71% RH	<b>6dB Bandwidth</b>	120 kHz
<b>Antenna Pole</b>	Vertical	<b>Antenna Distance</b>	10m
<b>Detector Function</b>	Quasi-peak.	<b>Tested by</b>	Kevin Chang
<b>Standard</b>	EN 55022 CLASS A		

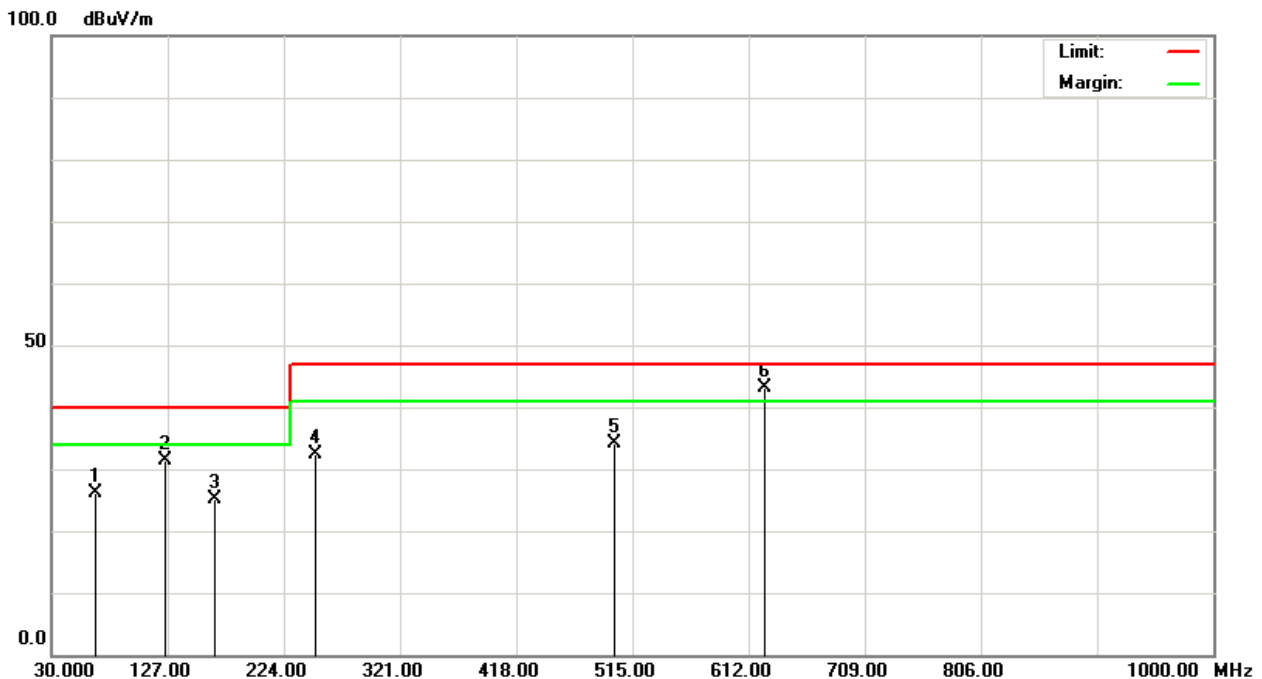

Radiated Emission Readings									
Frequency Range Investigated				30 MHz to 1000 MHz at 10m					
Freq. (MHz)	Reading (dBuV)	Factor (dB/m)	Result (dBuV/m)	Limit (dBuV/m)	Margin (dB)	Height (cm)	Degree (°)	Detector (P/Q)	Pol. (H/V)
66.6400	45.40	-19.17	26.23	40.00	-13.77	100	130	Q	V
125.0100	44.30	-12.87	31.43	40.00	-8.57	100	24	Q	V
166.0300	39.50	-14.25	25.25	40.00	-14.75	100	120	Q	V
250.0100	45.90	-13.51	32.39	47.00	-14.61	100	46	Q	V
500.1200	41.90	-7.78	34.12	47.00	-12.88	400	197	Q	V
624.9900	49.40	-6.15	43.25	47.00	-3.75	400	203	Q	V

Note: P= Peak Reading; Q= Quasi-peak Reading.

<b>Model No.</b>	FWS-7520W3-H25-A10-000	<b>Test Mode</b>	Mode 1
<b>Environmental Conditions</b>	22°C, 71% RH	<b>6dB Bandwidth</b>	120 kHz
<b>Antenna Pole</b>	Horizontal	<b>Antenna Distance</b>	10m
<b>Detector Function</b>	Quasi-peak.	<b>Tested by</b>	Kevin Chang
<b>Standard</b>	EN 55022 CLASS A		

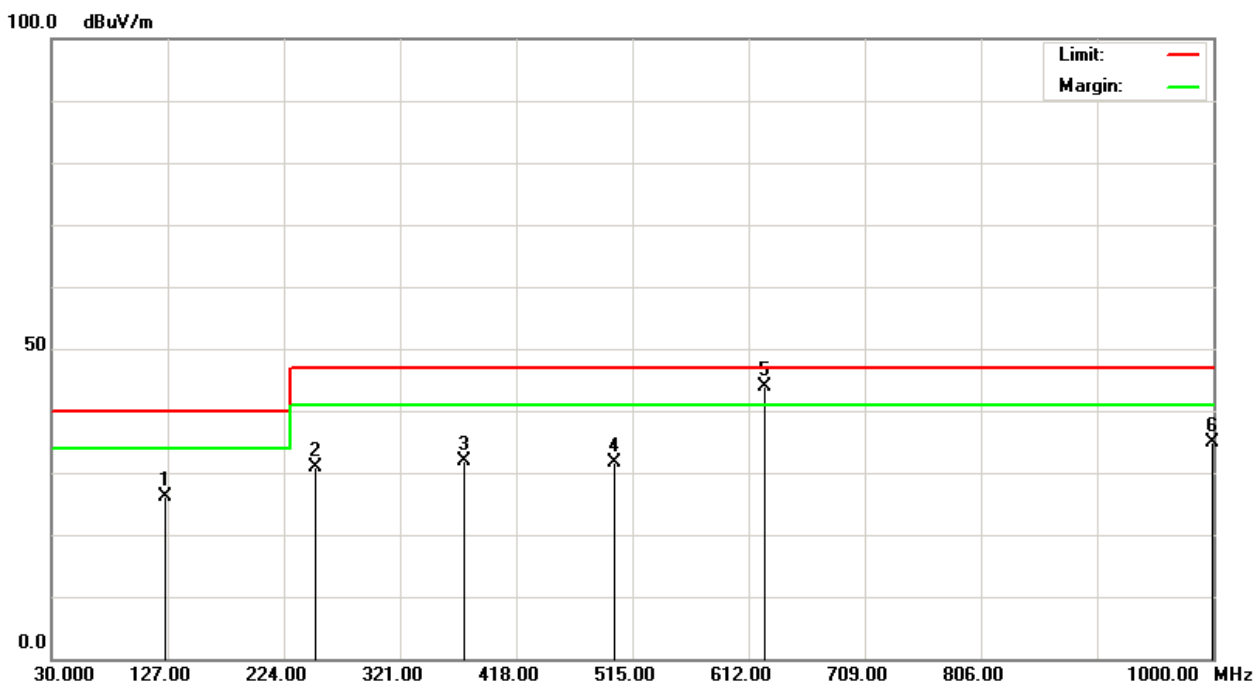

Radiated Emission Readings									
Frequency Range Investigated				30 MHz to 1000 MHz at 10m					
Freq. (MHz)	Reading (dBuV)	Factor (dB/m)	Result (dBuV/m)	Limit (dBuV/m)	Margin (dB)	Height (cm)	Degree (°)	Detector (P/Q)	Pol. (H/V)
125.0200	39.00	-12.87	26.13	40.00	-13.87	400	25	Q	H
250.0000	44.40	-13.52	30.88	47.00	-16.12	400	150	Q	H
375.0100	42.20	-10.34	31.86	47.00	-15.14	400	130	Q	H
500.0200	39.40	-7.78	31.62	47.00	-15.38	100	94	Q	H
624.9900	50.00	-6.15	43.85	47.00	-3.15	100	22	Q	H
999.9800	35.20	-0.43	34.77	47.00	-12.23	100	34	Q	H

Note: P= Peak Reading; Q= Quasi-peak Reading.

**Above 1GHz**

<b>Model No.</b>	FWS-7520W3-H25-A10-000	<b>Test Mode</b>	Mode 1
<b>Environmental Conditions</b>	23°C, 57% RH	<b>6dB Bandwidth</b>	1 MHz
<b>Antenna Pole</b>	Vertical / Horizontal	<b>Antenna Distance</b>	3m
<b>Highest frequency generated or used</b>	2000MHz	<b>Upper frequency</b>	6000MHz
<b>Detector Function</b>	Peak and average.	<b>Tested by</b>	David Cheng
<b>Standard</b>	EN 55022 CLASS A		

<b>Radiated Emission Readings</b>							
<b>Frequency Range Investigated</b>				<b>Above 1GHz at 3m</b>			
Freq. (MHz)	Reading (dBuV)	Factor (dB/m)	Result (dBuV/m)	Limit (dBuV/m)	Margin (dB)	Detector (P/A)	Pol. (H/V)
<b>1250.000</b>	<b>57.18</b>	<b>-8.34</b>	<b>48.84</b>	<b>76.00</b>	<b>-27.16</b>	<b>P</b>	<b>V</b>
<b>1375.000</b>	<b>52.77</b>	<b>-8.01</b>	<b>44.76</b>	<b>76.00</b>	<b>-31.24</b>	<b>P</b>	<b>V</b>
<b>1650.000</b>	<b>53.93</b>	<b>-6.36</b>	<b>47.57</b>	<b>76.00</b>	<b>-28.43</b>	<b>P</b>	<b>V</b>
<b>1933.333</b>	<b>53.48</b>	<b>-3.88</b>	<b>49.60</b>	<b>76.00</b>	<b>-26.40</b>	<b>P</b>	<b>V</b>
<b>2716.667</b>	<b>50.24</b>	<b>-2.36</b>	<b>47.88</b>	<b>76.00</b>	<b>-28.12</b>	<b>P</b>	<b>V</b>
<b>2858.333</b>	<b>50.14</b>	<b>-2.16</b>	<b>47.98</b>	<b>76.00</b>	<b>-28.02</b>	<b>P</b>	<b>V</b>

<b>Radiated Emission Readings</b>							
<b>Frequency Range Investigated</b>				<b>Above 1GHz at 3m</b>			
Freq. (MHz)	Reading (dBuV)	Factor (dB/m)	Result (dBuV/m)	Limit (dBuV/m)	Margin (dB)	Detector (P/A)	Pol. (H/V)
<b>1125.000</b>	<b>53.52</b>	<b>-8.69</b>	<b>44.83</b>	<b>76.00</b>	<b>-31.17</b>	<b>P</b>	<b>H</b>
<b>1583.333</b>	<b>54.05</b>	<b>-6.95</b>	<b>47.10</b>	<b>76.00</b>	<b>-28.90</b>	<b>P</b>	<b>H</b>
<b>1808.333</b>	<b>52.39</b>	<b>-4.97</b>	<b>47.42</b>	<b>76.00</b>	<b>-28.58</b>	<b>P</b>	<b>H</b>
<b>2500.000</b>	<b>49.17</b>	<b>-2.66</b>	<b>46.51</b>	<b>76.00</b>	<b>-29.49</b>	<b>P</b>	<b>H</b>
<b>2625.000</b>	<b>51.99</b>	<b>-2.50</b>	<b>49.49</b>	<b>76.00</b>	<b>-26.51</b>	<b>P</b>	<b>H</b>
<b>2791.667</b>	<b>49.25</b>	<b>-2.25</b>	<b>47.00</b>	<b>76.00</b>	<b>-29.00</b>	<b>P</b>	<b>H</b>

**Note:** P= Peak Reading; A= Average Reading.

## 7.4. HARMONICS CURRENT MEASUREMENT

### 7.4.1. LIMITS OF HARMONICS CURRENT MEASUREMENT

Limits for Class A equipment		Limits for Class D equipment		
Harmonics Order n	Max. permissible harmonics current A	Harmonics Order n	Max. permissible harmonics current per watt mA/W	Max. permissible harmonics current A
Odd harmonics		Odd Harmonics only		
3	2.30	3	3.4	2.30
5	1.14	5	1.9	1.14
7	0.77	7	1.0	0.77
9	0.40	9	0.5	0.40
11	0.33	11	0.35	0.33
13	0.21	13	0.30	0.21
15<=n<=39	0.15x15/n	15<=n<=39	3.85/n	0.15x15/n
Even harmonics				
2	1.08			
4	0.43			
6	0.30			
8<=n<=40	0.23x8/n			

**NOTE:** 1. Class A and Class D are classified according to item 7.4.3.

2. According to section 7 of EN 61000-3-2, the above limits for all equipment except for lighting equipment having an active input power > 75 W and no limits apply for equipment with an active input power up to and including 75 W.

### 7.4.2. TEST INSTRUMENTS

Name of Equipment	Manufacturer	Model	Serial Number	Calibration Due
5kVA Power Source	Teseq	5001IX-208-TSQ	1537A01296	11/10/2016
H/F Measurement System	EMC Partner	HAR1000-1P	189	11/10/2016
Software	HARCS V4.19			

**NOTE:** The calibration interval of the above test instruments is 12 months and the calibrations are traceable to NML/ROC and NIST/USA.

**7.4.3. TEST PROCEDURE** (please refer to measurement standard or CCS SOP PA-029)

- The EUT was placed on the top of a wooden table 0.8 meters above the ground and operated to produce the maximum harmonic components under normal operating conditions for each successive harmonic component in turn.
- The classification of EUT is according to section 5 of EN 61000-3-2.
- The EUT is classified as follows:

Class A: Balanced three-phase equipment, Household appliances excluding equipment as Class D, Tools excluding portable tools, Dimmers for incandescent lamps, audio equipment, equipment not specified in one of the three other classes.

Class B: Portable tools; Arc welding equipment which is not professional equipment.

Class C: Lighting equipment.

Class D: Equipment having a specified power less than or equal to 600 W of the following types: Personal computers and personal computer monitors; television receivers and refrigerators and freezers having one or more variable-speed drives to control compressor motor(s).

- The correspondent test program of test instrument to measure the current harmonics emanated from EUT is chosen. The measure time shall be not less than the time necessary for the EUT to be exercised.

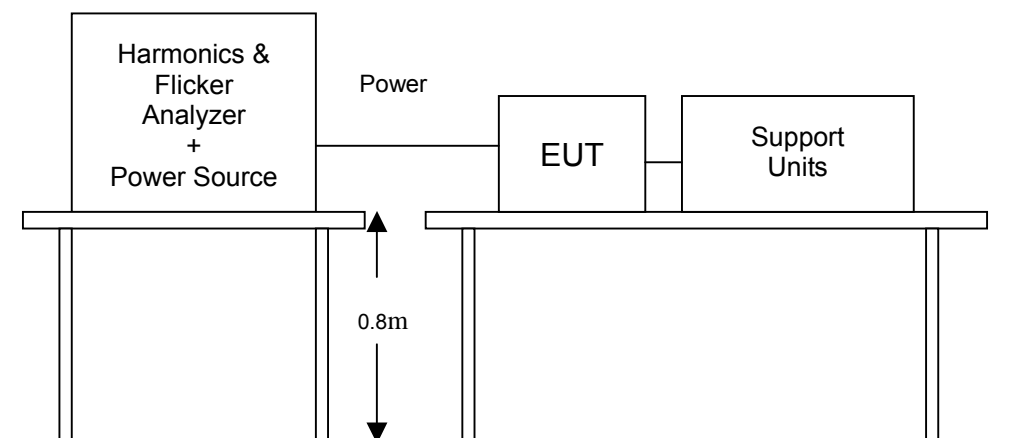
**7.4.4. TEST SETUP**

- For the actual test configuration, please refer to the related item – Photographs of the Test Configuration.

7.4.5. TEST RESULTS

Power Consumption	51.29W	Test Results	PASS
Environmental Conditions	20°C, 56% RH, 1009mbar	Limits	Class <input checked="" type="checkbox"/> A <input type="checkbox"/> B <input type="checkbox"/> C <input type="checkbox"/> D
Test Mode	Operating	Tested by	David Cheng

NOTE: Limits classified according to item 7.4.1.

Test result of EN 61000-3-2

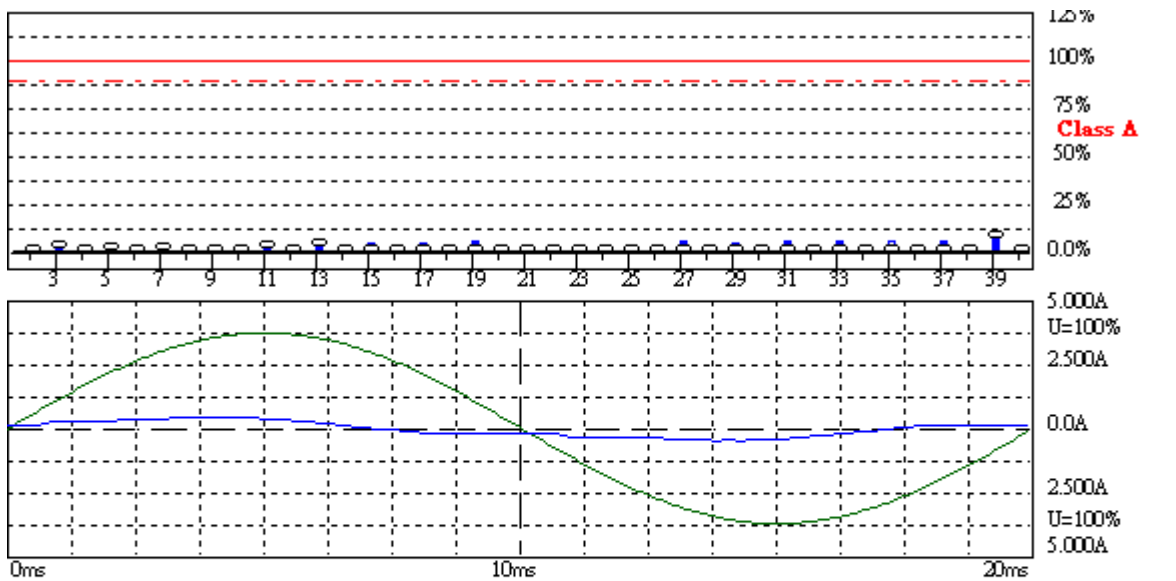

Harmonic Emission - IEC 61000-3-2 , EN 61000-3-2 , (EN60555-2)

2016/4/28 21:51:13

U<sub>rms</sub> = 229.9 V    P = 51.29 W    THC = 0.071 A  
 I<sub>rms</sub> = 0.291 A    pf = 0.768

Range: 5 A  
 V<sub>nom</sub>: 230 V  
 TestTime: 30 min (100%)

FWS-7520

Test completed, Result: PASSED

HAR-1000 EMC-Header

Urms = 229.9V      Freq = 50.000      Range: 5 A  
 Irms = 0.291A      Ipk = 0.486A      cf = 1.672  
 P = 51.29W      S = 66.80VA      pf = 0.768  
 THDi = 25.3 %      THDu = 0.10 %      Class A

Test - Time :30min      ( 100 %)

Test completed, Result: PASSED

Order	Freq. [Hz]	Iavg [A]	Irms [A]	Irms% [%]	Irms%L [%]	Imax [A]	Imax% [%]	Imax%L [%]	Limit [A]	Status
1	50	0.2783	0.2817	96.954		0.2972	102.31			
2	100	0.0000	0.0018	0.6303	0.1695	0.0031	1.0504	0.2826	1.0800	
3	150	0.0666	0.0665	22.899	2.8925	0.0681	23.424	2.9589	2.3000	
4	200	0.0000	0.0003	0.1050	0.0710	0.0006	0.2101	0.1419	0.4300	
5	250	0.0158	0.0156	5.3571	1.3653	0.0177	6.0924	1.5526	1.1400	
6	300	0.0000	0.0003	0.1050	0.1017	0.0006	0.2101	0.2035	0.3000	
7	350	0.0102	0.0101	3.4664	1.3079	0.0122	4.2017	1.5853	0.7700	
8	400	0.0000	0.0003	0.1050	0.1327	0.0003	0.1050	0.1327	0.2300	
9	450	0.0049	0.0049	1.6807	1.2207	0.0067	2.3109	1.6785	0.4000	
10	500	0.0000	0.0003	0.1050	0.1659	0.0006	0.2101	0.3317	0.1840	
11	550	0.0076	0.0076	2.6261	2.3119	0.0092	3.1513	2.7743	0.3300	
12	600	0.0000	0.0003	0.1050	0.1990	0.0006	0.2101	0.3981	0.1533	
13	650	0.0065	0.0064	2.2059	3.0518	0.0079	2.7311	3.7784	0.2100	
14	700	0.0000	0.0003	0.1050	0.2322	0.0003	0.1050	0.2322	0.1314	
15	750	0.0000	0.0040	1.3655	2.6449	0.0049	1.6807	3.2552	0.1500	
16	800	0.0000	0.0003	0.1050	0.2654	0.0003	0.1050	0.2654	0.1150	
17	850	0.0000	0.0040	1.3655	2.9975	0.0046	1.5756	3.4587	0.1324	
18	900	0.0000	0.0003	0.1050	0.2985	0.0006	0.2101	0.5971	0.1022	
19	950	0.0001	0.0043	1.4706	3.6079	0.0049	1.6807	4.1233	0.1184	
20	1000	0.0000	0.0003	0.1050	0.3317	0.0003	0.1050	0.3317	0.0920	
21	1050	0.0000	0.0018	0.6303	1.7090	0.0031	1.0504	2.8483	0.1071	
22	1100	0.0000	0.0003	0.1050	0.3649	0.0006	0.2101	0.7298	0.0836	
23	1150	0.0000	0.0006	0.2101	0.6239	0.0021	0.7353	2.1837	0.0978	
24	1200	0.0000	0.0003	0.1050	0.3981	0.0006	0.2101	0.7961	0.0767	
25	1250	0.0000	0.0015	0.5252	1.6954	0.0024	0.8403	2.7127	0.0900	
26	1300	0.0000	0.0003	0.1050	0.4312	0.0006	0.2101	0.8625	0.0708	
27	1350	0.0000	0.0037	1.2605	4.3945	0.0043	1.4706	5.1270	0.0833	
28	1400	0.0000	0.0006	0.2101	0.9288	0.0006	0.2101	0.9288	0.0657	
29	1450	0.0000	0.0021	0.7353	2.7534	0.0027	0.9454	3.5400	0.0776	
30	1500	0.0000	0.0006	0.2101	0.9951	0.0006	0.2101	0.9951	0.0613	
31	1550	0.0000	0.0034	1.1555	4.6251	0.0037	1.2605	5.0456	0.0726	
32	1600	0.0000	0.0006	0.2101	1.0615	0.0006	0.2101	1.0615	0.0575	
33	1650	0.0000	0.0031	1.0504	4.4759	0.0034	1.1555	4.9235	0.0682	
34	1700	0.0000	0.0006	0.2101	1.1278	0.0006	0.2101	1.1278	0.0541	
35	1750	0.0000	0.0009	0.3151	1.4242	0.0024	0.8403	3.7977	0.0643	
36	1800	0.0000	0.0006	0.2101	1.1942	0.0009	0.3151	1.7912	0.0511	
37	1850	0.0000	0.0031	1.0504	5.0184	0.0031	1.0504	5.0184	0.0608	
38	1900	0.0000	0.0006	0.2101	1.2605	0.0009	0.3151	1.8908	0.0484	
39	1950	0.0042	0.0049	1.6807	8.4635	0.0052	1.7857	8.9925	0.0577	
40	2000	0.0000	0.0009	0.3151	1.9903	0.0012	0.4202	2.6537	0.0460	

**Definitions of Abbreviations**

Urms	***	Actual total Voltage in Volt RMS
Irms	***	Actual total Current in Ampere RMS
Ipk	***	Actual Peak value of the Current in Ampere
cf	***	Actual Crest Factor (Ipk/Irms)
P	***	Actual Active Power in Watt
S	***	Actual Apparent Power in VA (Urms*Irms)
pf	***	Actual Power Factor (P/S)
THDi	***	Actual Total Harmonic Current Distortion in %
THDu	***	Actual Total Harmonic Voltage Distortion in %
THC	***	Actual Total Harmonic Current in Ampere
PHC	***	Actual Partial Harmonic Current in Ampere

Individual measurements for 2nd to 40th order:

lavg		Average value of the Individual Harmonic Current in Ampere RMS
Irms	***	Actual Individual Harmonic Current in Ampere RMS
Irms%	***	Actual Individual Harmonic Current in percentage of the actual total RMS Current
Irms%L	***	Actual Individual Harmonic Current in percentage of the applicable Limit
Imax		Maximum Individual Harmonic Current in Ampere RMS
Imax%		Maximum Individual Harmonic Current in percentage of the actual total RMS Current
Imax%lim		Maximum Individual Harmonic Current in percentage of the applicable Limit
Limit Irms		Individual Limit (100%) for the selected Class in Ampere RMS



## 7.5. VOLTAGE FLUCTUATION AND FLICKER MEASUREMENT

### 7.5.1. LIMITS OF VOLTAGE FLUCTUATION AND FLICKER MEASUREMENT

TEST ITEM	LIMIT	REMARK
$P_{st}$	1.0	$P_{st}$ means short-term flicker indicator.
$P_{lt}$	0.65	$P_{lt}$ means long-term flicker indicator.
$T_{dt}$ (ms)	500	$T_{dt}$ means maximum time that dt exceeds 3 %.
$d_{max}$ (%)	4%	$d_{max}$ means maximum relative voltage change.
dc (%)	3.3%	dc means relative steady-state voltage change

### 7.5.2. TEST INSTRUMENTS

Name of Equipment	Manufacturer	Model	Serial Number	Calibration Due
5kVA Power Source	Teseq	5001IX-208-TSQ	1537A01296	11/10/2016
H/F Measurement System	EMC Partner	HAR1000-1P	189	11/10/2016
Software	HARCS V4.19			

**NOTE:** The calibration interval of the above test instruments is 12 months and the calibrations are traceable to NML/ROC and NIST/USA.

### 7.5.3. TEST PROCEDURE (please refer to measurement standard or CCS SOP PA-030)

- The EUT was placed on the top of a wooden table 0.8 meters above the ground and operated to produce the most unfavorable sequence of voltage changes under normal operating conditions.
- During the flick measurement, the measure time shall include that part of whole operation cycle in which the EUT produce the most unfavorable sequence of voltage changes. The observation period for short-term flicker indicator is 10 minutes and the observation period for long-term flicker indicator is 2 hours.

### 7.5.4. TEST SETUP

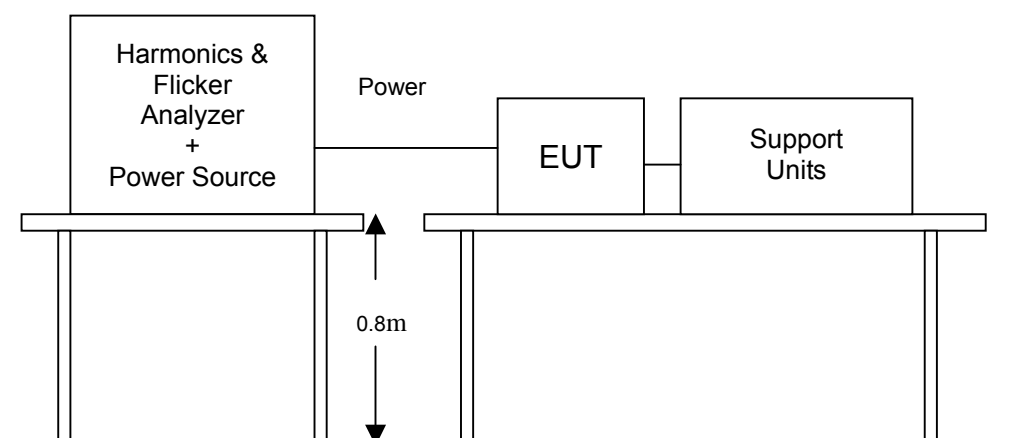

- For the actual test configuration, please refer to the related item – Photographs of the Test Configuration.

7.5.5. TEST RESULTS

Observation Period (Tp)	30mins	Test Mode	Operating
Environmental Conditions	20°C, 56% RH, 1009mbar	Tested by	David Cheng

TEST PARAMETER	MEASUREMENT VALUE	LIMIT	REMARK
P <sub>st</sub>	0.07	1.0	PASS
P <sub>lt</sub>	0.07	0.65	PASS
T <sub>dt</sub> (ms)	0	500	PASS
d <sub>max</sub> (%)	0	4%	PASS
dc (%)	0.01	3.3%	PASS

Note: None.

Test result of EN 61000-3-3

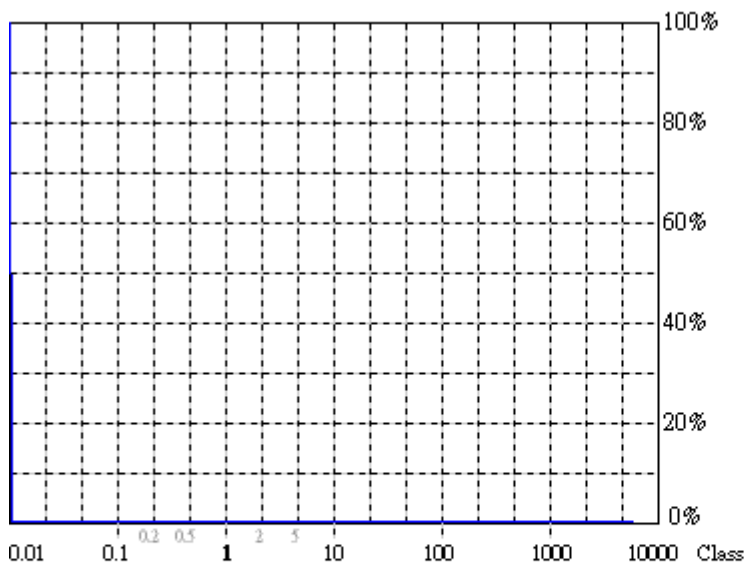

**Actual Flicker (Fli): 0.00**  
**Short-term Flicker (Pst): 0.07**  
 Limit (Pst): 1.00  
**Long-term Flicker (Plt): 0.07**  
 Limit (Plt): 0.65  
**Maximum Relative Volt. Change (dmax): 0.00%**  
 Limit (dmax): 4.00%  
**Relative Steady-state Voltage Change (dc): 0.01%**  
 Limit (dc): 3.30%  
**Maximum Interval exceeding 3.30% (dt): 0.00ms**  
 Limit (dt>Lim): 500ms

Flicker Emission - IEC 61000-3-3 , EN 61000-3-3

2016/4/28 21:02:34

U<sub>rms</sub> = 229.9 V P = 51.91 W  
 I<sub>rms</sub> = 0.298 A pf = 0.771

Range: 5 A  
 V<sub>nom</sub>: 230 V  
 TestTime: 30 min (100%)

FWS-7520

Test completed, Result: PASSED

BAR-1000 EMC-Retester

## 8 IMMUNITY TEST

### 8.1. GENERAL DESCRIPTION

Product Standard	EN 55024: 2010	
	Test Type	Minimum Requirement
<b>Basic Standard, Specification, and Performance Criterion required</b>	IEC 61000-4-2	Electrostatic Discharge – ESD: 8kV air discharge, 4kV Contact discharge, Performance Criterion B  According to special request by client: 12kV air discharge, 6kV Contact discharge
	IEC 61000-4-3	Radio-Frequency Electromagnetic Field Susceptibility Test – RS: 80 ~1000 MHz, 3V/m, 80% AM(1kHz), Performance Criterion A
	IEC 61000-4-4	Electrical Fast Transient/Burst - EFT, AC Power Port: 1kV DC Power Port: 0.5kV Signal Ports and Telecommunication Ports: 0.5kV Performance Criterion B
	IEC 61000-4-5	Surge Immunity Test: 1.2/50 $\mu$ s Open Circuit Voltage, 8/20 $\mu$ s Short Circuit Current, AC Power Port ~ line to line: 1kV, line to ground: 2kV DC Power Port ~ line to ground: 0.5kV Signal Ports and Telecommunication Ports ~ line to ground: 1kV Performance Criterion B 10/700 $\mu$ s Open Circuit Voltage, Performance Criterion C
	IEC 61000-4-6	Conducted Radio Frequency Disturbances Test – CS: 0.15 ~ 80 MHz, 3Vrms, 80% AM, 1kHz, Performance Criterion A
	IEC 61000-4-8	Power frequency magnetic field immunity test 50 Hz or 60 Hz, 1A/m, Performance Criterion A
	IEC 61000-4-11	<b>Voltage Dips:</b> i) >95% reduction for 0.5 period, Performance Criterion B ii) 30% reduction for 25 period, Performance Criterion C <b>Voltage Interruptions:</b> >95% reduction for 250 period Performance Criterion C

**8.2. GENERAL PERFORMANCE CRITERIA DESCRIPTION**

<p><b>Criteria A:</b></p>	<p>The apparatus shall continue to operate as intended without operator intervention. No degradation of performance or loss of function is allowed below a performance level specified by the manufacturer, when the apparatus is used as intended. The performance level may be replaced by a permissible loss of performance. If the manufacturer does not specify the minimum performance level or the permissible performance loss, then either of these may be derived from the product description and documentation, and by what the user may reasonably expect from the equipment if used as intended.</p>
<p><b>Criteria B:</b></p>	<p>After test, the apparatus shall continue to operate as intended without operator intervention. No degradation of performance or loss of function is allowed, after the application of the phenomenon below a performance level specified by the manufacturer, when the apparatus is used as intended. The performance level may be replaced by a permissible loss of performance.</p> <p>During the test, degradation of performance is however allowed. However, no change of operating state if stored data is allowed to persist after the test. If the manufacturer does not specify the minimum performance level or the permissible performance loss, then either of these may be derived from the product description and documentation, and by what the user may reasonably expect from the equipment if used as intended.</p>
<p><b>Criteria C:</b></p>	<p>Temporary loss of function is allowed, provided the functions is self-recoverable or can be restored by the operation of controls by the user in accordance with the manufacturer instructions.</p> <p>Functions, and/or information stored in non-volatile memory, or protected by a battery backup, shall not be lost.</p>

### 8.3. ELECTROSTATIC DISCHARGE (ESD)

#### 8.3.1. TEST SPECIFICATION

<b>Basic Standard:</b>	IEC 61000-4-2
<b>Discharge Impedance:</b>	330 ohm / 150 pF
<b>Discharge Voltage:</b>	Air Discharge: 2 ; 4 ; 8 ; 12 kV (Direct) Contact Discharge: 2 ; 4 ; 6 kV (Direct/Indirect)
<b>Polarity:</b>	Positive & Negative
<b>Number of Discharge:</b>	Air Discharge: min. 10 times at each test point for each polarity Contact Discharge: min. 200 times in total
<b>Discharge Mode:</b>	Single Discharge 1 second minimum

#### 8.3.2. TEST INSTRUMENT

IMMUNITY SHIELDED ROOM				
Name of Equipment	Manufacturer	Model	Serial Number	Calibration Due
Aneroid Barometer	SATO	7610-20	89090	10/15/2016
ESD Generator	Teseq	NSG 437	249	12/13/2016
Thermo-Hygro Meter	Tecpel	DTM-303	80269	04/14/2017

**NOTE:** The calibration interval of the above test instruments is 12 months and the calibrations are traceable to NML/ROC and NIST/USA.

**8.3.3. TEST PROCEDURE** (please refer to measurement standard or CCS SOP PA-022)

The discharges shall be applied in two ways:

## a) Contact discharges to the conductive surfaces and coupling planes:

The EUT shall be exposed to at least 200 discharges, 100 each at negative and positive polarity, at a minimum of four test points. One of the test points shall be subjected to at least 50 indirect discharges to the center of the front edge of the **Horizontal Coupling Plane (HCP)**. The remaining three test points shall each receive at least 50 direct contact discharges. If no direct contact test points are available, then at least 200 indirect discharges shall be applied in the indirect mode. Test shall be performed at a maximum repetition rate of one discharge per second.

## b) Air discharges at slots and apertures and insulating surfaces:

On those parts of the EUT where it is not possible to perform contact discharge testing, the equipment should be investigated to identify user accessible points where breakdown may occur. Such points are tested using the air discharge method. This investigation should be restricted to those area normally handled by the user. A minimum of 10 single air discharges shall be applied to the selected test point for each such area.

The basic test procedure was in accordance with IEC 61000-4-2:

- a) The EUT was located 0.1 m minimum from all side of the **HCP** (dimensions 1.6m x 0.8m).
- b) The support units were located another table 30 cm away from the EUT, but direct support unit was/were located at same location as EUT on the HCP and keep at a distance of 10 cm with EUT.
- c) The time interval between two successive single discharges was at least 1 second.
- d) Contact discharges were applied to the non-insulating coating, with the pointed tip of the generator penetrating the coating and contacting the conducting substrate.
- e) Air discharges were applied with the round discharge tip of the discharge electrode approaching the EUT as fast as possible (without causing mechanical damage) to touch the EUT. After each discharge, the ESD generator was removed from the EUT and re-triggered for a new single discharge. The test was repeated until all discharges were complete.
- f) At least ten single discharges (in the most sensitive polarity) were applied at the front edge of each **HCP** opposite the center point of each unit of the EUT and 0.1 meters from the front of the EUT. The long axis of the discharge electrode was in the plane of the **HCP** and perpendicular to its front edge during the discharge.
- g) At least ten single discharges (in the most sensitive polarity) were applied to the center of one vertical edge of the **Vertical Coupling Plane (VCP)** in sufficiently different positions that the four faces of the EUT were completely illuminated. The **VCP** (dimensions 0.5m x 0.5m) was placed vertically to and 0.1 meters from the EUT.

### 8.3.4. TEST SETUP

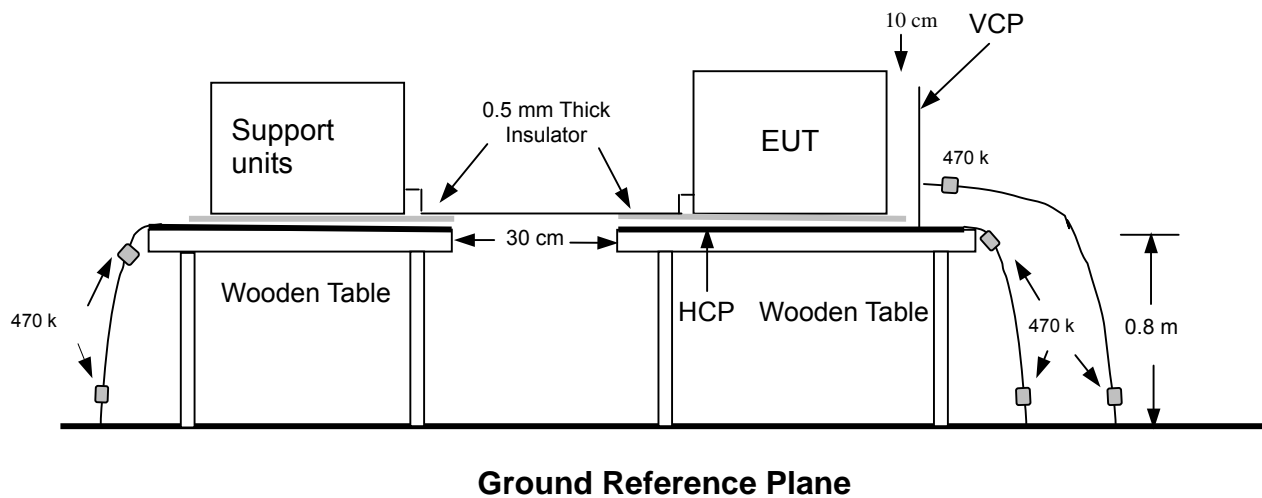

- For the actual test configuration, please refer to the related item – Photographs of the Test Configuration.

#### NOTE:

##### TABLE-TOP EQUIPMENT

The configuration consisted of a wooden table 0.8 meters high standing on the **Ground Reference Plane**. The **GRP** consisted of a sheet of aluminum at least 0.25mm thick, and 2.5 meters square connected to the protective grounding system. A **Horizontal Coupling Plane** (1.6m x 0.8m) was placed on the table and attached to the **GRP** by means of a cable with 940k total impedance. The equipment under test, was installed in a representative system as described in section 7 of IEC 61000-4-2, and its cables were placed on the **HCP** and isolated by an insulating support of 0.5mm thickness. A distance of 1-meter minimum was provided between the EUT and the walls of the laboratory and any other metallic structure.

##### FLOOR-STANDING EQUIPMENT

The equipment under test was installed in a representative system as described in section 7 of IEC 61000-4-2, and its cables were isolated from the Ground Reference Plane by an insulating support of 0.1-meter thickness. The GRP consisted of a sheet of aluminum that is at least 0.25mm thick, and 2.5 meters square connected to the protective grounding system and extended at least 0.5 meters from the EUT on all sides.

8.3.5. TEST RESULTS

Temperature	20°C	Humidity	56% RH
Pressure	1009mbar	Tested By	David Cheng
Required Passing Performance		Criterion B	

Air Discharge									
Test Points	Test Levels				Results				
	± 2 KV	± 4 KV	± 8 KV	± 12 KV	Pass	Fail	Performance Criterion		Observation
Front	<input checked="" type="checkbox"/>	<input checked="" type="checkbox"/>	<input checked="" type="checkbox"/>	<input checked="" type="checkbox"/>	<input checked="" type="checkbox"/>	<input type="checkbox"/>	<input checked="" type="checkbox"/> A	<input type="checkbox"/> B	Note <input type="checkbox"/> 1 <input checked="" type="checkbox"/> 2
Back	<input checked="" type="checkbox"/>	<input checked="" type="checkbox"/>	<input checked="" type="checkbox"/>	<input checked="" type="checkbox"/>	<input checked="" type="checkbox"/>	<input type="checkbox"/>	<input checked="" type="checkbox"/> A	<input type="checkbox"/> B	Note <input checked="" type="checkbox"/> 1 <input type="checkbox"/> 2

Contact Discharge								
Test Points	Test Levels			Results				
	± 2 KV	± 4 KV	± 6 KV	Pass	Fail	Performance Criterion		Observation
Front	<input checked="" type="checkbox"/>	<input checked="" type="checkbox"/>	<input checked="" type="checkbox"/>	<input checked="" type="checkbox"/>	<input type="checkbox"/>	<input checked="" type="checkbox"/> A	<input type="checkbox"/> B	Note <input checked="" type="checkbox"/> 1 <input type="checkbox"/> 2
Back	<input checked="" type="checkbox"/>	<input checked="" type="checkbox"/>	<input checked="" type="checkbox"/>	<input checked="" type="checkbox"/>	<input type="checkbox"/>	<input checked="" type="checkbox"/> A	<input type="checkbox"/> B	Note <input checked="" type="checkbox"/> 1 <input type="checkbox"/> 2
Left	<input checked="" type="checkbox"/>	<input checked="" type="checkbox"/>	<input checked="" type="checkbox"/>	<input checked="" type="checkbox"/>	<input type="checkbox"/>	<input checked="" type="checkbox"/> A	<input type="checkbox"/> B	Note <input checked="" type="checkbox"/> 1 <input type="checkbox"/> 2
Right	<input checked="" type="checkbox"/>	<input checked="" type="checkbox"/>	<input checked="" type="checkbox"/>	<input checked="" type="checkbox"/>	<input type="checkbox"/>	<input checked="" type="checkbox"/> A	<input type="checkbox"/> B	Note <input checked="" type="checkbox"/> 1 <input type="checkbox"/> 2
Top	<input checked="" type="checkbox"/>	<input checked="" type="checkbox"/>	<input checked="" type="checkbox"/>	<input checked="" type="checkbox"/>	<input type="checkbox"/>	<input checked="" type="checkbox"/> A	<input type="checkbox"/> B	Note <input checked="" type="checkbox"/> 1 <input type="checkbox"/> 2

Discharge To Horizontal Coupling Plane								
Side of EUT	Test Levels			Results				
	± 2 kV	± 4 kV	± 6 kV	Pass	Fail	Performance Criterion		Observation
Front	<input checked="" type="checkbox"/>	<input checked="" type="checkbox"/>	<input checked="" type="checkbox"/>	<input checked="" type="checkbox"/>	<input type="checkbox"/>	<input checked="" type="checkbox"/> A	<input type="checkbox"/> B	Note <input checked="" type="checkbox"/> 1 <input type="checkbox"/> 2
Back	<input checked="" type="checkbox"/>	<input checked="" type="checkbox"/>	<input checked="" type="checkbox"/>	<input checked="" type="checkbox"/>	<input type="checkbox"/>	<input checked="" type="checkbox"/> A	<input type="checkbox"/> B	Note <input checked="" type="checkbox"/> 1 <input type="checkbox"/> 2
Left	<input checked="" type="checkbox"/>	<input checked="" type="checkbox"/>	<input checked="" type="checkbox"/>	<input checked="" type="checkbox"/>	<input type="checkbox"/>	<input checked="" type="checkbox"/> A	<input type="checkbox"/> B	Note <input checked="" type="checkbox"/> 1 <input type="checkbox"/> 2
Right	<input checked="" type="checkbox"/>	<input checked="" type="checkbox"/>	<input checked="" type="checkbox"/>	<input checked="" type="checkbox"/>	<input type="checkbox"/>	<input checked="" type="checkbox"/> A	<input type="checkbox"/> B	Note <input checked="" type="checkbox"/> 1 <input type="checkbox"/> 2

Discharge To Vertical Coupling Plane								
Side of EUT	Test Levels			Results				
	± 2 kV	± 4 kV	± 6 kV	Pass	Fail	Performance Criterion		Observation
Front	<input checked="" type="checkbox"/>	<input checked="" type="checkbox"/>	<input checked="" type="checkbox"/>	<input checked="" type="checkbox"/>	<input type="checkbox"/>	<input checked="" type="checkbox"/> A	<input type="checkbox"/> B	Note <input checked="" type="checkbox"/> 1 <input type="checkbox"/> 2
Back	<input checked="" type="checkbox"/>	<input checked="" type="checkbox"/>	<input checked="" type="checkbox"/>	<input checked="" type="checkbox"/>	<input type="checkbox"/>	<input checked="" type="checkbox"/> A	<input type="checkbox"/> B	Note <input checked="" type="checkbox"/> 1 <input type="checkbox"/> 2
Left	<input checked="" type="checkbox"/>	<input checked="" type="checkbox"/>	<input checked="" type="checkbox"/>	<input checked="" type="checkbox"/>	<input type="checkbox"/>	<input checked="" type="checkbox"/> A	<input type="checkbox"/> B	Note <input checked="" type="checkbox"/> 1 <input type="checkbox"/> 2
Right	<input checked="" type="checkbox"/>	<input checked="" type="checkbox"/>	<input checked="" type="checkbox"/>	<input checked="" type="checkbox"/>	<input type="checkbox"/>	<input checked="" type="checkbox"/> A	<input type="checkbox"/> B	Note <input checked="" type="checkbox"/> 1 <input type="checkbox"/> 2

**NOTE:** 1. There was no change compared with initial operation during the test.  
 2. No discharge point.



The Photo for Discharge Points of EUT  
Front



Back



Red Dot —Air Discharged  
Blue Dot —Contact Discharged

**Left**



**Right**



Red Dot —Air Discharged  
Blue Dot —Contact Discharged

**Top**



Red Dot —Air Discharged  
Blue Dot —Contact Discharged

## 8.4. RADIATED, RADIO-FREQUENCY, ELECTROMAGNETIC FIELD (RS)

### 8.4.1. TEST SPECIFICATION

<b>Basic Standard:</b>	IEC 61000-4-3
<b>Frequency Range:</b>	80 MHz ~1000 MHz
<b>Field Strength:</b>	3 V/m
<b>Modulation:</b>	1kHz Sine Wave, 80%, AM Modulation
<b>Frequency Step:</b>	1 % of preceding frequency value
<b>Polarity of Antenna:</b>	Horizontal and Vertical
<b>Test Distance:</b>	3 m
<b>Antenna Height:</b>	1.5m

### 8.4.2. TEST INSTRUMENT

844 RS Chamber				
Name of Equipment	Manufacturer	Model	Serial Number	Calibration Due
Broadband Antenna	AR	AT1080	311819	N.C.R
Direction Coupler	AR	DC6180A	312189	N.C.R
Electric Field Probe	AR	FL7006	338955	06/14/2016
Field of Calibration	CCS	Chamber#RS	80-1000MHz	04/01/2017
Power Amplifier	AR	500W1000A	320994	N.C.R
Power Sensor	Boonton	51013-4E	35811	03/09/2017
Power Sensor	Boonton	51013-4E	35812	03/09/2017
RF Power Meter	Boonton	4242/1/2	14357	03/09/2017
Signal Generator	Agilent	N5181A	MY47421336	12/10/2016
Thermo-Hygro Meter	TFA	N/A	NO.6	10/25/2016
Software	Emcware Ver. 2.6.0.16			

**NOTE:** 1. The calibration interval of the above test instruments is 12 months and the calibrations are traceable to NML/ROC and NIST/USA.  
 2. N.C.R.= No Calibration required.

### 8.4.3. TEST PROCEDURE (please refer to measurement standard or CCS SOP PA-023)

The test procedure was in accordance with IEC 61000-4-3

- The testing was performed in a fully anechoic chamber. The transmit antenna was located at a distance of 3 meters from the EUT.
- The frequency range is swept from 80 MHz to 1000 MHz, with the signal 80% amplitude modulated with a 1kHz sine-wave. The rate of sweep did not exceed  $1.5 \times 10^{-3}$  decade/s, where the frequency range is swept incrementally, the step size was 1% of preceding frequency value.
- The dwell time at each frequency shall be not less than the time necessary for the EUT to be able to respond.
- The test was performed with the EUT exposed to both vertically and horizontally polarized fields on each of the four sides.

**8.4.4. TEST SETUP**

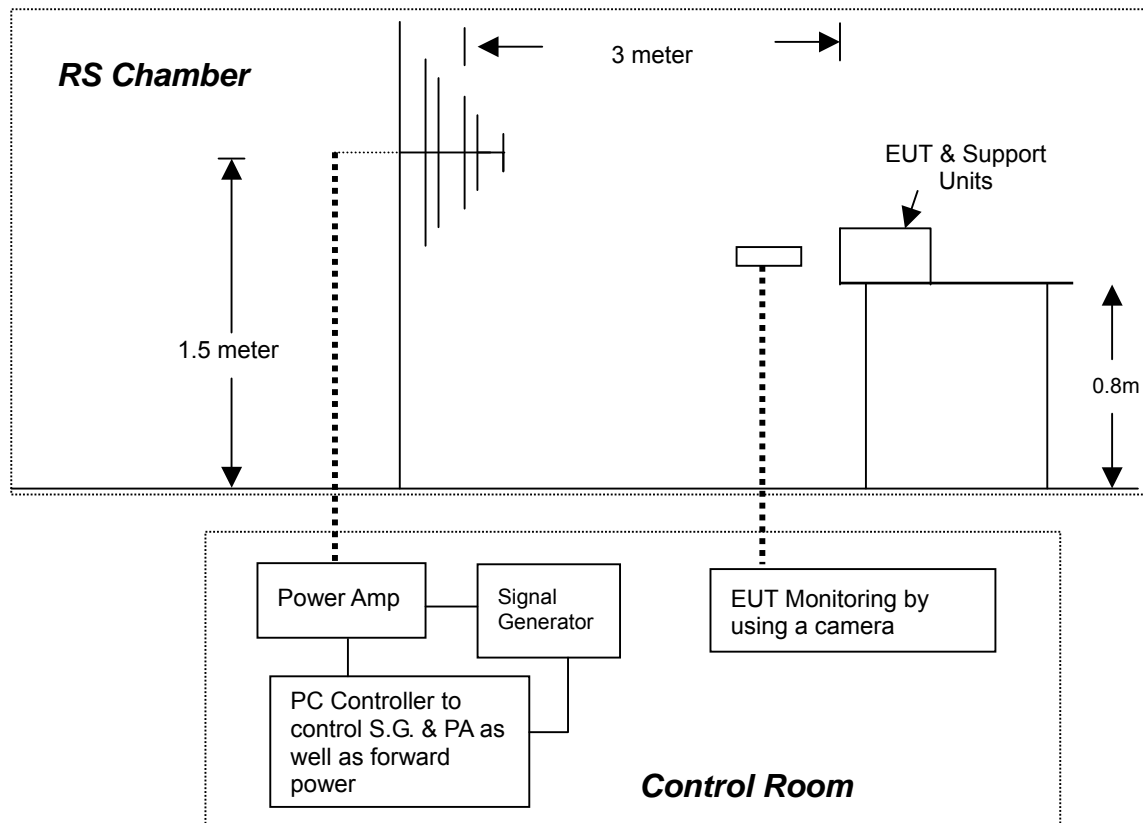

- For the actual test configuration, please refer to the related item – Photographs of the Test Configuration.

**NOTE:**

TABLETOP EQUIPMENT

The EUT installed in a representative system as described in section 7 of IEC 61000-4-3 was placed on a non-conductive table 0.8 meters in height. The system under test was connected to the power and signal wire according to relevant installation instructions.

FLOOR STANDING EQUIPMENT

The EUT installed in a representative system as described in section 7 of IEC 61000-4-3 was placed on a non-conductive wood support 0.1 meters in height. The system under test was connected to the power and signal wire according to relevant installation instructions.

**8.4.5. TEST RESULTS**

<b>Temperature</b>	20°C	<b>Humidity</b>	56% RH
<b>Pressure</b>	1009mbar	<b>Dwell Time</b>	3 sec.
<b>Tested By</b>	David Cheng	<b>Required Passing Performance</b>	<b>Criterion A</b>

Frequency (MHz)	Polarity	Azimuth	Field Strength (V/m)	Performance Criterion	Observation	Result
80 ~ 1000	V&H	0	3	<input checked="" type="checkbox"/> A <input type="checkbox"/> B	Note <input checked="" type="checkbox"/> 1 <input type="checkbox"/> 2	PASS
80 ~ 1000	V&H	90	3	<input checked="" type="checkbox"/> A <input type="checkbox"/> B	Note <input checked="" type="checkbox"/> 1 <input type="checkbox"/> 2	PASS
80 ~ 1000	V&H	180	3	<input checked="" type="checkbox"/> A <input type="checkbox"/> B	Note <input checked="" type="checkbox"/> 1 <input type="checkbox"/> 2	PASS
80 ~ 1000	V&H	270	3	<input checked="" type="checkbox"/> A <input type="checkbox"/> B	Note <input checked="" type="checkbox"/> 1 <input type="checkbox"/> 2	PASS

**NOTE:** 1. There was no change compared with the initial operation during the test.

**8.5. ELECTRICAL FAST TRANSIENT (EFT)**

**8.5.1. TEST SPECIFICATION**

<b>Basic Standard:</b>	IEC 61000-4-4
<b>Test Voltage:</b>	AC Power Port: 1kV Signal Ports and Telecommunication Ports: 0.5kV
<b>Polarity:</b>	Positive & Negative
<b>Impulse Frequency:</b>	5 kHz
<b>Impulse Wave-shape:</b>	5/50 ns
<b>Burst Duration:</b>	15 ms
<b>Burst Period:</b>	300 ms
<b>Test Duration:</b>	Not less than 1 min.

**8.5.2. TEST INSTRUMENT**

Immunity Shield Room				
Name of Equipment	Manufacturer	Model	Serial Number	Calibration Due
Capacitive Clamp	EMC-Partner	CN-EFT1000	589	07/21/2016
EMC Immunity Tester	EMC Partner	TRANSINT 2000	1117	03/10/2017
Software	GenecsVer. 3.27			

**NOTE:** 1. The calibration interval of the above test instruments is 12 months and the calibrations are traceable to NML/ROC and NIST/USA.  
2. N.C.R.= No Calibration required.

**8.5.3. TEST PROCEDURE** (please refer to measurement standard or CCS SOP PA-024)

- a) All types of cables, including their length, and the interface port of the EUT to which they were connected.
- b) Both positive and negative polarity discharges were applied.
- c) The length of the “ hot wire ” from the coaxial output of the EFT generator to the terminals on the EUT should not exceed 0.5 meter.
- d) The duration time of each test sequential was 1 minute.
- e) The transient/burst waveform was in accordance with IEC 61000-4-4, 5/50ns.

8.5.4. TEST SETUP

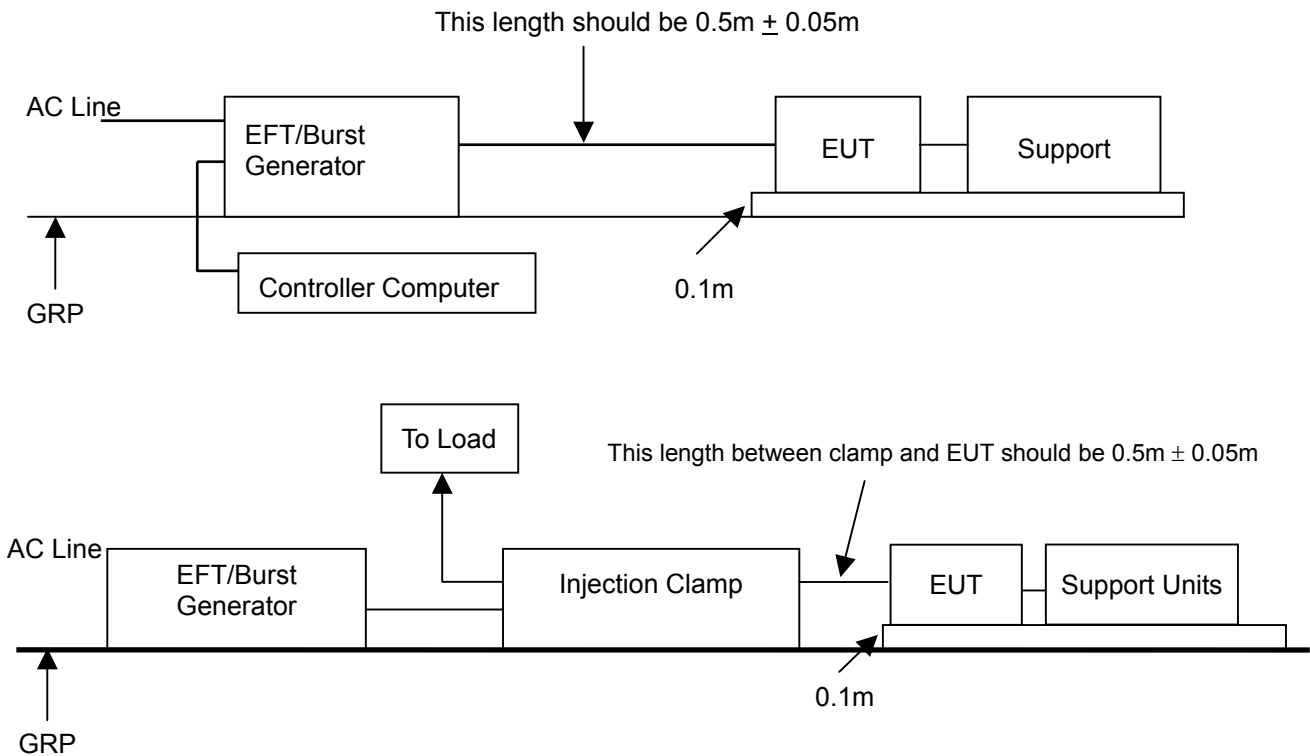

- For the actual test configuration, please refer to the related item – Photographs of the Test Configuration.

**NOTE:**

TABLETOP EQUIPMENT

The configuration consisted of a wooden table (0.1m high) standing on the Ground Reference Plane. The GRP consisted of a sheet of aluminum (at least 0.25mm thick and 2.5m square) connected to the protective grounding system. A minimum distance of 0.5m was provided between the EUT and the walls of the laboratory or any other metallic structure.

FLOOR STANDING EQUIPMENT

The EUT installed in a representative system as described in section 7 of IEC 61000-4-4 and its cables, were isolated from the Ground Reference Plane by an insulating support that is 0.1-meter thick. The GRP consisted of a sheet of aluminum (at least 0.25mm thick and 2.5m square) connected to the protective grounding system.



**8.5.5. TEST RESULTS**

<b>Temperature</b>	20°C	<b>Humidity</b>	56% RH
<b>Pressure</b>	1009mbar	<b>Tested By</b>	David Cheng
<b>Required Passing Performance</b>		<b>Criterion B</b>	

Test Point	Polarity	Test Level (kV)	Performance Criterion	Observation	Result
L	+/-	1	<input checked="" type="checkbox"/> A <input type="checkbox"/> B	Note <input checked="" type="checkbox"/> 1 <input type="checkbox"/> 2	PASS
N	+/-	1	<input checked="" type="checkbox"/> A <input type="checkbox"/> B	Note <input checked="" type="checkbox"/> 1 <input type="checkbox"/> 2	PASS
L – N	+/-	1	<input checked="" type="checkbox"/> A <input type="checkbox"/> B	Note <input checked="" type="checkbox"/> 1 <input type="checkbox"/> 2	PASS
PE	+/-	1	<input checked="" type="checkbox"/> A <input type="checkbox"/> B	Note <input checked="" type="checkbox"/> 1 <input type="checkbox"/> 2	PASS
L – PE	+/-	1	<input checked="" type="checkbox"/> A <input type="checkbox"/> B	Note <input checked="" type="checkbox"/> 1 <input type="checkbox"/> 2	PASS
N – PE	+/-	1	<input checked="" type="checkbox"/> A <input type="checkbox"/> B	Note <input checked="" type="checkbox"/> 1 <input type="checkbox"/> 2	PASS
L – N – PE	+/-	1	<input checked="" type="checkbox"/> A <input type="checkbox"/> B	Note <input checked="" type="checkbox"/> 1 <input type="checkbox"/> 2	PASS
RJ45	+/-	0.5	<input checked="" type="checkbox"/> A <input type="checkbox"/> B	Note <input checked="" type="checkbox"/> 1 <input type="checkbox"/> 2	PASS

**NOTE:** 1. There was no change compared with initial operation during the test.

## 8.6. SURGE IMMUNITY TEST

### 8.6.1. TEST SPECIFICATION

<b>Basic Standard:</b>	IEC 61000-4-5
<b>Wave-Shape:</b>	Combination Wave 1.2/50 µs Open Circuit Voltage 8/20 µs Short Circuit Current 10/700 µs Open Circuit Voltage
<b>Test Voltage:</b>	AC Power Port~ line to line: 1kV, line to ground: 2kV Signal Ports and Telecommunication Ports: 1kV
<b>Surge Input/Output:</b>	AC Power Line: L-N / L-PE / N-PE Signal Line: L-G
<b>Generator Source Impedance:</b>	2 ohm between networks 12 ohm between network and ground 42 ohm between network and ground
<b>Polarity:</b>	Positive/Negative
<b>Phase Angle:</b>	0° / 90° / 180° / 270°
<b>Pulse Repetition Rate:</b>	1 time / min. (maximum)
<b>Number of Tests:</b>	5 positive and 5 negative at selected points

### 8.6.2. TEST INSTRUMENT

Immunity Shield Room				
Name of Equipment	Manufacturer	Model	Serial Number	Calibration Due
CDN	EMC-Partner	CDN-UTP8	1505	02/22/2017
EMC Immunity Tester	EMC Partner	TRANSINT 2000	1117	03/10/2017
Software	GenecsVer. 3.27			

**NOTE:** 1. The calibration interval of the above test instruments is 12 months and the calibrations are traceable to NML/ROC and NIST/USA.  
2. N.C.R.= No Calibration required.

### 8.6.3. TEST PROCEDURE (please refer to measurement standard or CCS SOP PA-025)

a) For EUT power supply:

The surge is applied to the EUT power supply terminals via the capacitive coupling network. Decoupling networks are required in order to avoid possible adverse effects on equipment not under test that may be powered by the same lines, and to provide sufficient decoupling impedance to the surge wave. The power cord between the EUT and the coupling/decoupling networks was shorter than 2 meters in length.

b) For test applied to unshielded un-symmetrically operated interconnection lines of EUT:

The surge was applied to the lines via the capacitive coupling. The coupling / decoupling networks didn't influence the specified functional conditions of the EUT. The interconnection line between the EUT and the coupling/decoupling networks was shorter than 2 meters in length.

c) For test applied to unshielded symmetrically operated interconnection / telecommunication lines of EUT:

The surge was applied to the lines via gas arrestors coupling. Test levels below the ignition point of the coupling arrestor were not specified. The interconnection line between the EUT and the coupling/decoupling networks was shorter than 2 meters in length.

**8.6.4. TEST SETUP**

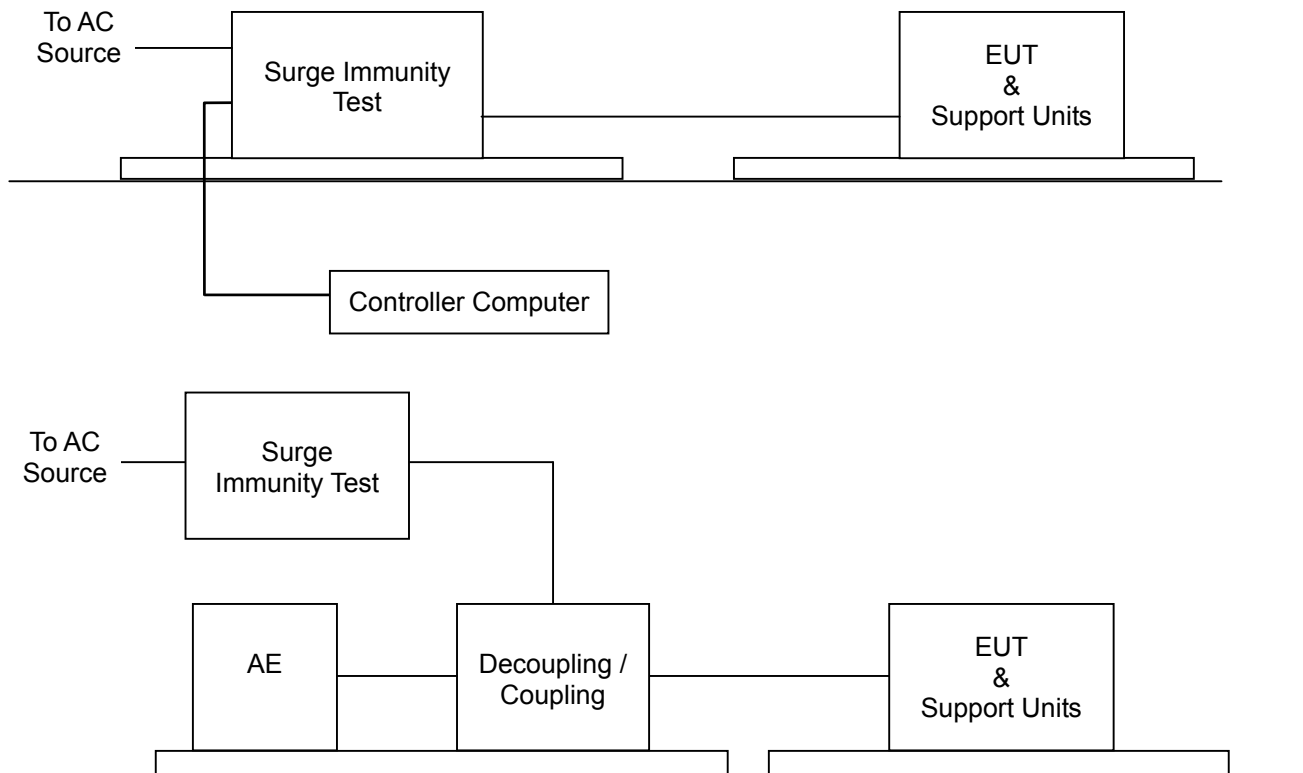

- For the actual test configuration, please refer to the related item – Photographs of the Test Configuration.

**8.6.5. TEST RESULTS**

**Power Supply: FSP / FSP180-50LG**

<b>Temperature</b>	20°C	<b>Humidity</b>	56% RH
<b>Pressure</b>	1009mbar	<b>Tested By</b>	David Cheng
<b>Required Passing Performance</b>		<b>Criterion B</b>	

Test Point	Polarity	Test Level (kV)	Performance Criterion	Observation	Result
L - N	+/-	1	<input checked="" type="checkbox"/> A <input type="checkbox"/> B	Note <input checked="" type="checkbox"/> 1 <input type="checkbox"/> 2	PASS
L - PE	+/-	2	<input checked="" type="checkbox"/> A <input type="checkbox"/> B	Note <input checked="" type="checkbox"/> 1 <input type="checkbox"/> 2	PASS
N - PE	+/-	2	<input checked="" type="checkbox"/> A <input type="checkbox"/> B	Note <input checked="" type="checkbox"/> 1 <input type="checkbox"/> 2	PASS

**NOTE:** 1. There was no change compared with initial operation during the test.

<b>Temperature</b>	20°C	<b>Humidity</b>	56% RH
<b>Pressure</b>	1009mbar	<b>Tested By</b>	David Cheng
<b>Required Passing Performance</b>		<b>Criterion C</b>	

Test Point	Polarity	Test Level (kV)	Performance Criterion	Observation	Result
RJ45	+/-	1	<input checked="" type="checkbox"/> A <input type="checkbox"/> B <input type="checkbox"/> C	Note <input checked="" type="checkbox"/> 1 <input type="checkbox"/> 2	PASS

**NOTE:** 1. There was no change compared with initial operation during the test.

**Power Supply: ETASIS / EFAP-S250**

<b>Temperature</b>	19°C	<b>Humidity</b>	58% RH
<b>Pressure</b>	1009mbar	<b>Tested By</b>	Stanley Cheng
<b>Required Passing Performance</b>		<b>Criterion B</b>	

Test Point	Polarity	Test Level (kV)	Performance Criterion	Observation	Result
L - N	+/-	1	<input checked="" type="checkbox"/> A <input type="checkbox"/> B	Note <input checked="" type="checkbox"/> 1 <input type="checkbox"/> 2	PASS
L - PE	+/-	2	<input checked="" type="checkbox"/> A <input type="checkbox"/> B	Note <input checked="" type="checkbox"/> 1 <input type="checkbox"/> 2	PASS
N - PE	+/-	2	<input checked="" type="checkbox"/> A <input type="checkbox"/> B	Note <input checked="" type="checkbox"/> 1 <input type="checkbox"/> 2	PASS

**NOTE:** 1. There was no change compared with initial operation during the test.

<b>Temperature</b>	19°C	<b>Humidity</b>	58% RH
<b>Pressure</b>	1009mbar	<b>Tested By</b>	Stanley Cheng
<b>Required Passing Performance</b>		<b>Criterion C</b>	

Test Point	Polarity	Test Level (kV)	Performance Criterion	Observation	Result
RJ45	+/-	1	<input checked="" type="checkbox"/> A <input type="checkbox"/> B <input type="checkbox"/> C	Note <input checked="" type="checkbox"/> 1 <input type="checkbox"/> 2	PASS

**NOTE:** 1. There was no change compared with initial operation during the test.

## 8.7. CONDUCTED RADIO FREQUENCY DISTURBANCES (CS)

### 8.7.1. TEST SPECIFICATION

<b>Basic Standard:</b>	IEC 61000-4-6
<b>Frequency Range:</b>	0.15 MHz ~ 80 MHz
<b>Field Strength:</b>	3 Vrms
<b>Modulation:</b>	1kHz Sine Wave, 80%, AM Modulation
<b>Frequency Step:</b>	1 % of preceding frequency value
<b>Coupled cable:</b>	Power Mains, Unshielded; RJ45 Line, Unshielded
<b>Coupling device:</b>	CDN-M3 (3 wires); CDN-T8

### 8.7.2. TEST INSTRUMENT

CS Room				
Name of Equipment	Manufacturer	Model	Serial Number	Calibration Due
Attenuator	EMCI	SA3NL	10006F	N.C.R
CDN	Teseq	CDN M016	35820	02/22/2017
CDN	Teseq	CDN M016	35821	02/22/2017
CDN	Teseq	CDN T400A	25674	01/11/2017
CDN	Teseq	CDN T8-10	40369	02/22/2017
Continuous Wave Simulator	EM Test	CWS 500N1.4	P1446143188	02/21/2017
Software	icd.control Ver. 5.1.9			

- NOTE:** 1. The calibration interval of the above test instruments is 12 months and the calibrations are traceable to NML/ROC and NIST/USA.  
2. N.C.R.= No Calibration required.

### 8.7.3. TEST PROCEDURE (please refer to measurement standard or CCS SOP PA-026)

The EUT shall be tested within its intended operating and climatic conditions.

The test shall be performed with the test generator connected to each of the coupling and decoupling devices in turn, while the other non-excited RF input ports of the coupling devices are terminated by a 50-ohm load resistor.

The frequency range was swept from 150 kHz to 80 MHz, using the signal level established during the setting process and with a disturbance signal of 80 % amplitude. The signal was modulated with a 1 kHz sine wave, pausing to adjust the RF signal level or the switch coupling devices as necessary. The sweep rate was  $1.5 \times 10^{-3}$  decades/s. Where the frequency range is swept incrementally, the step size was 1 % of preceding frequency value from 150 kHz to 80 MHz.

The dwell time at each frequency was less than the time necessary for the EUT to be exercised, and able to respond. Sensitive frequencies such as clock frequency(ies) and harmonics or frequencies of dominant interest, was analyzed separately.

Attempts were made to fully exercise the EUT during testing, and to fully interrogate all exercise modes selected for susceptibility.

8.7.4. TEST SETUP

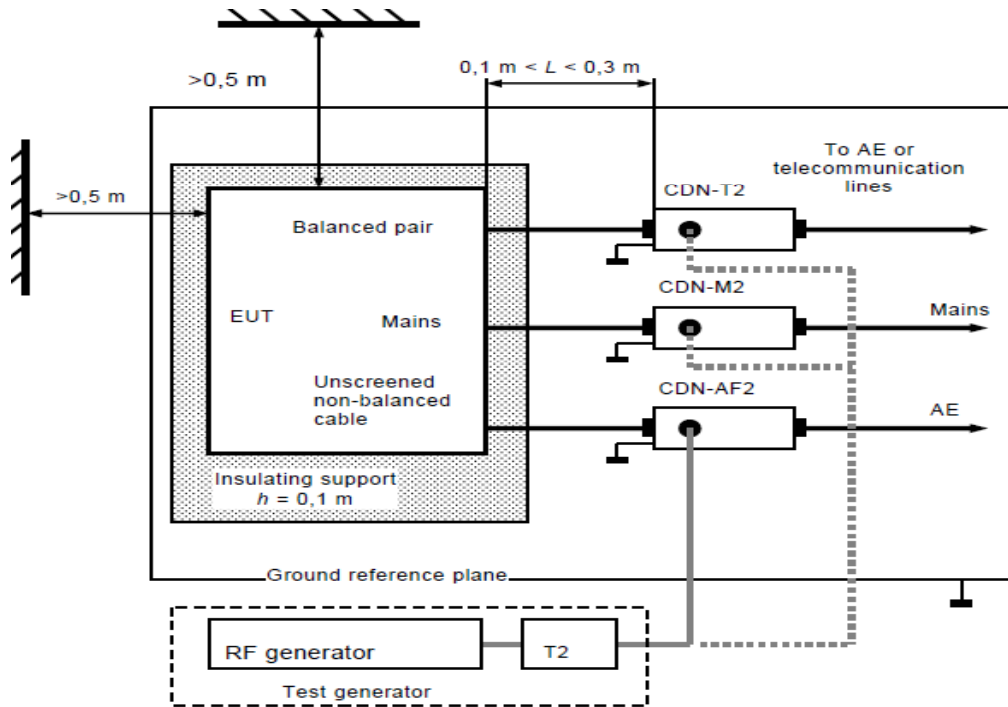

- Note:** 1. The CDNs and / or EM clamp used for real test depends on ports and cables configuration of EUT.  
 2. The EUT clearance from any metallic obstacles shall be at least 0.5m

- For the actual test configuration, please refer to the related item – Photographs of the Test Configuration.

**NOTE:**

TABLE-TOP AND FLOOR-STANDING EQUIPMENT

The equipment to be tested is placed on an insulating support of 0.1 meters height above a ground reference plane. All relevant cables shall be provided with the appropriate coupling and decoupling devices at a distance between 0.1 meters and 0.3 meters from the projected geometry of the EUT on the ground reference plane.

8.7.5. TEST RESULTS

Temperature	20°C	Humidity	56% RH
Pressure	1009mbar	Tested By	David Cheng
Required Passing Performance		Criterion A	

Frequency Band (MHz)	Field Strength (Vrms)	Cable	Injection Method	Performance Criterion	Observation	Result
0.15 ~ 80	3	AC Power Line (0.3m)	CDN-M3	<input checked="" type="checkbox"/> A <input type="checkbox"/> B	Note <input checked="" type="checkbox"/> 1 <input type="checkbox"/> 2	PASS
0.15 ~ 80	3	RJ45 Line (0.3m)	CDN-T8	<input checked="" type="checkbox"/> A <input type="checkbox"/> B	Note <input checked="" type="checkbox"/> 1 <input type="checkbox"/> 2	PASS

**NOTE:** 1. There was no change compared with initial operation during the test.

**8.8. POWER FREQUENCY MAGNETIC FIELD**

**8.8.1. TEST SPECIFICATION**

<b>Basic Standard:</b>	IEC 61000-4-8
<b>Frequency Range:</b>	50Hz
<b>Field Strength:</b>	1 A/m
<b>Observation Time:</b>	1 minute
<b>Inductance Coil:</b>	Rectangular type, 1mx1m

**8.8.2. TEST INSTRUMENT**

Immunity Shield Room				
Name of Equipment	Manufacturer	Model	Serial Number	Calibration Due

**NOTE:** 1. The calibration interval of the above test instruments is 12 months and the calibrations are traceable to NML/ROC and NIST/USA.  
 2. N.C.R.= No Calibration required.

**8.8.3. TEST PROCEDURE** (please refer to measurement standard or CCS SOP PA-027)

- a. The equipment is configured and connected to satisfy its functional requirements. It shall be placed on the GRP with the interposition of a 0.1m-thick insulating support.
- b. The equipment cabinets shall be connected to the safety earth directly on the GRP via the earth terminal of the EUT.
- c. The power supply, input and output circuits shall be connected to the sources of power supply, control and signal.
- d. The cables supplied or recommended by the equipment manufacturer shall be used. 1 meter of all cables used shall be exposed to the magnetic field.



8.8.4. TEST SETUP

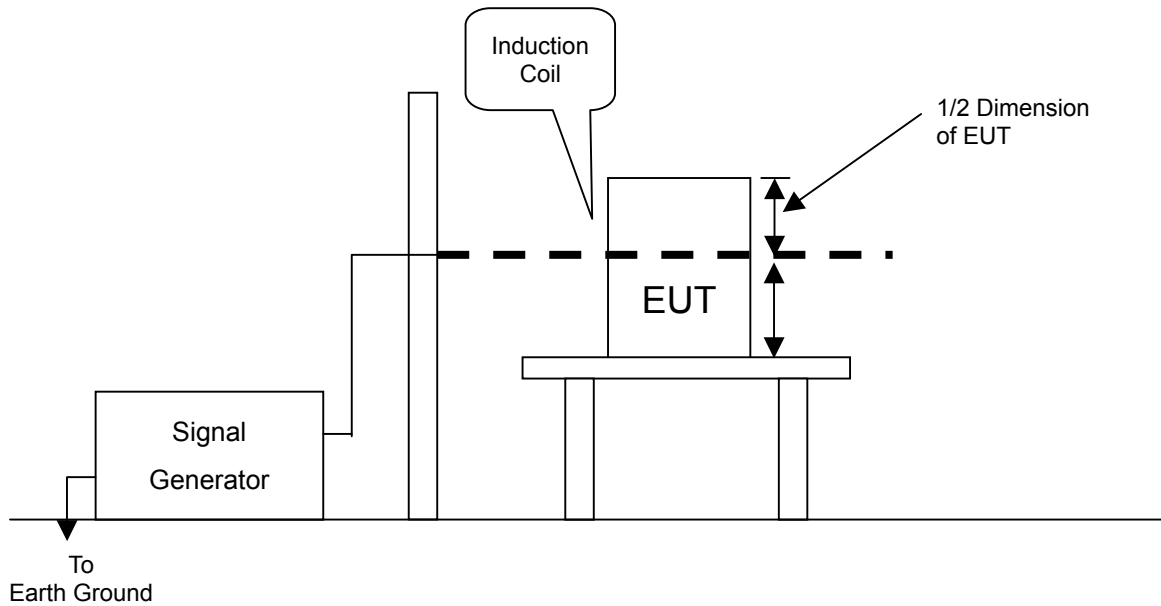

- For the actual test configuration, please refer to the related item – Photographs of the Test Configuration.

**NOTE:**

TABLETOP EQUIPMENT

The equipment shall be subjected to the test magnetic field by using the induction coil of standard dimension (1 m x 1 m). The induction coil shall then be rotated by 90 degrees in order to expose the EUT to the test field with different orientations.

FLOOR-STANDING EQUIPMENT

The equipment shall be subjected to the test magnetic field by using induction coils of suitable dimensions. The test shall be repeated by moving and shifting the induction coils, in order to test the whole volume of the EUT for each orthogonal direction. The test shall be repeated with the coil shifted to different positions along the side of the EUT, in steps corresponding to 50 % of the shortest side of the coil. The induction coil shall then be rotated by 90 degrees in order to expose the EUT to the test field with different orientations.

8.8.5. TEST RESULTS

Temperature	N/A	Humidity	N/A
Pressure	N/A	Tested By	N/A
Required Passing Performance		Criterion A	

Direction	Field Strength (A/m)	Performance Criterion	Observation	Results
X	1	A	Note	N/A
Y	1	A	Note	N/A
Z	1	A	Note	N/A

**NOTE:** There was no change compared with the initial operation during the test.

## 8.9. VOLTAGE DIPS & VOLTAGE INTERRUPTIONS

### 8.9.1. TEST SPECIFICATION

**Basic Standard:** IEC 61000-4-11

**Test duration time:** Minimum three test events in sequence

**Interval between event:** Minimum 10 seconds

**Phase Angle:** 0° / 180°

**Test cycle:** 3 times

### 8.9.2. TEST INSTRUMENT

Immunity shielded room				
Name of Equipment	Manufacturer	Model	Serial Number	Calibration Due
AC/DC Clamp Meter	Lutron	CM-9930R	I.200121	05/26/2016
EMC Immunity Tester	EMC Partner	TRANSINT 2000	1117	03/10/2017
Software	GenecsVer. 3.27			

**NOTE:** 1. The calibration interval of the above test instruments is 12 months and the calibrations are traceable to NML/ROC and NIST/USA.  
2. N.C.R.= No Calibration required.

### 8.9.3. TEST PROCEDURE (please refer to measurement standard or CCS SOP PA-028)

1. The EUT and support units were located on a wooden table, 0.8 m away from ground floor.
2. Setting the parameter of tests and then perform the test software of test simulator.
3. Conditions changes to occur at 0 degree crossover point of the voltage waveform.
4. Recording the test result in test record form.

**8.9.4. TEST SETUP**

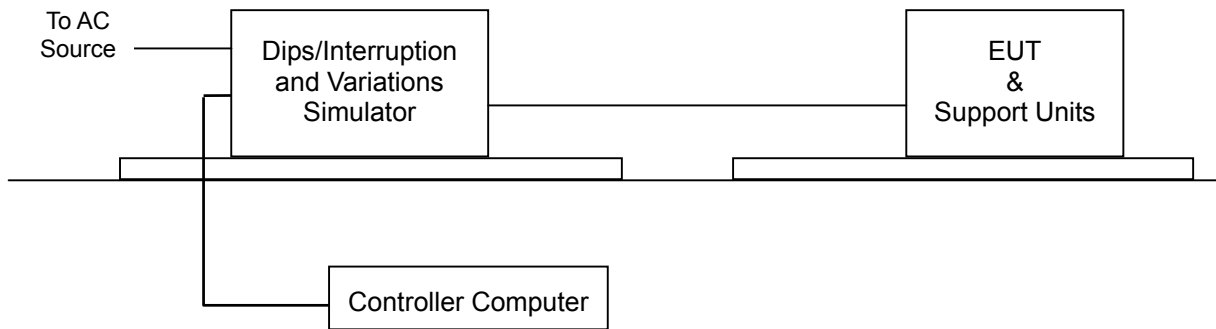

- For the actual test configuration, please refer to the related item – Photographs of the Test Configuration.

**8.9.5. TEST RESULTS**

<b>Temperature</b>	20°C	<b>Humidity</b>	56% RH
<b>Pressure</b>	1009mbar	<b>Tested By</b>	David Cheng
<b>Required Passing Performance</b>	<b>Criterion B: &gt;95% reduction 0.5 period</b> <b>Criterion C: 30% reduction 25 period &amp; &gt;95% reduction 250 period</b>		

Test Power: 230Vac, 50Hz				
Voltage (% Reduction)	Duration (Period)	Performance Criterion	Observation	Test Result
>95	0.5	<input checked="" type="checkbox"/> A <input type="checkbox"/> B <input type="checkbox"/> C	Note <input checked="" type="checkbox"/> 1 <input type="checkbox"/> 2	PASS
30	25	<input checked="" type="checkbox"/> A <input type="checkbox"/> B <input type="checkbox"/> C	Note <input checked="" type="checkbox"/> 1 <input type="checkbox"/> 2	PASS
>95	250	<input type="checkbox"/> A <input type="checkbox"/> B <input checked="" type="checkbox"/> C	Note <input type="checkbox"/> 1 <input checked="" type="checkbox"/> 2	PASS

- NOTE:** 1. There was no change compared with initial operation during and after the test. No unintentional response was found during the test.  
 2. EUT shut down, it could not become normal except reinstalled by operator.

## 9 PHOTOGRAPHS OF THE TEST CONFIGURATION CONDUCTED EMISSION TEST



**CONDUCTED EMISSION TEST AT TELECOMMUNICATION PORTS  
RJ45 Telecom Port with ISN (10Mbps & 100Mbps & 1Gbps)**

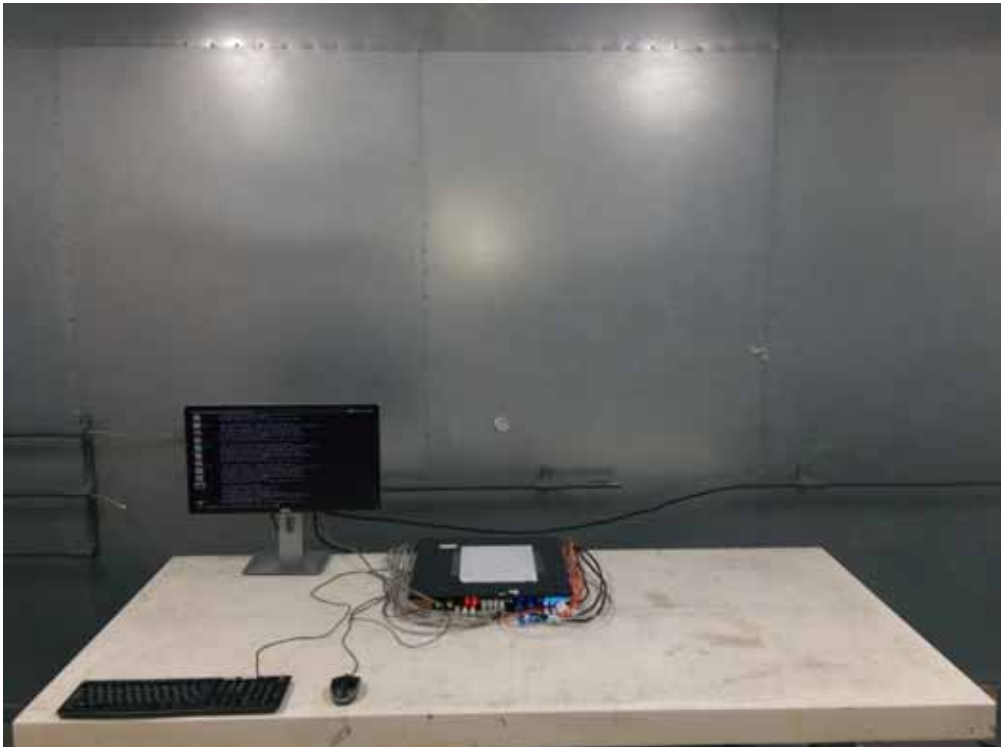

## RADIATED EMISSION TEST



### Harmonic & Flicker Test



### ESD Test





### RS Test



### EFT Test





### EFT For I/O Test

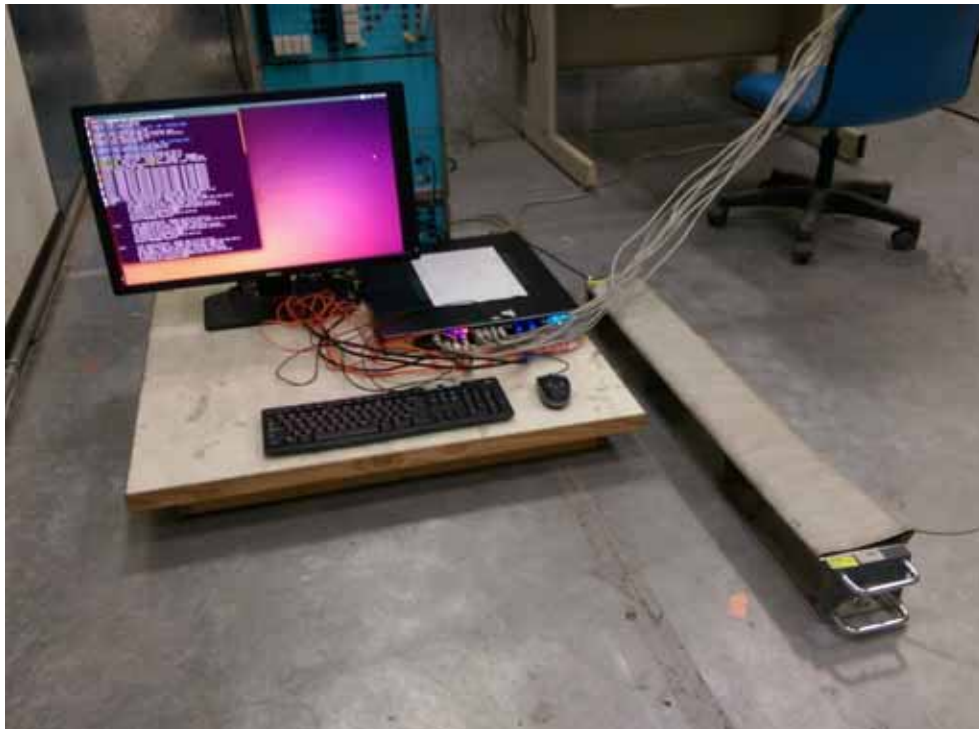

### Surge Test



### Surge For I/O Test



### CS Test

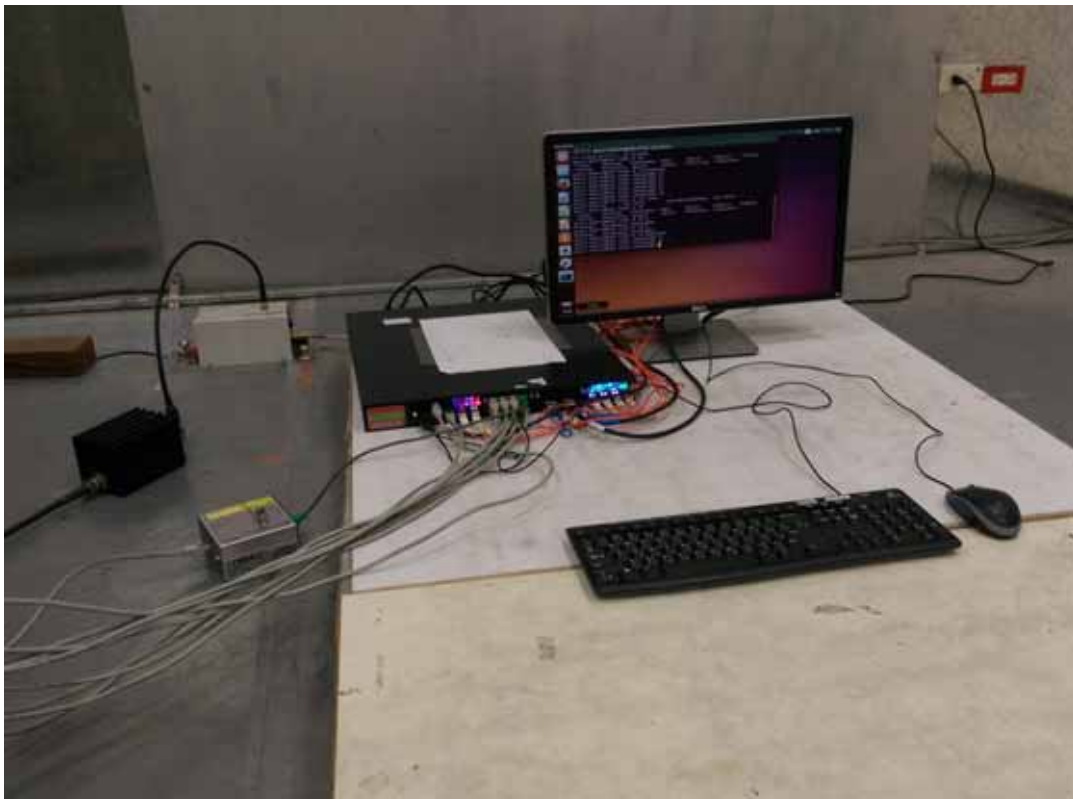

### CS For I/O Test

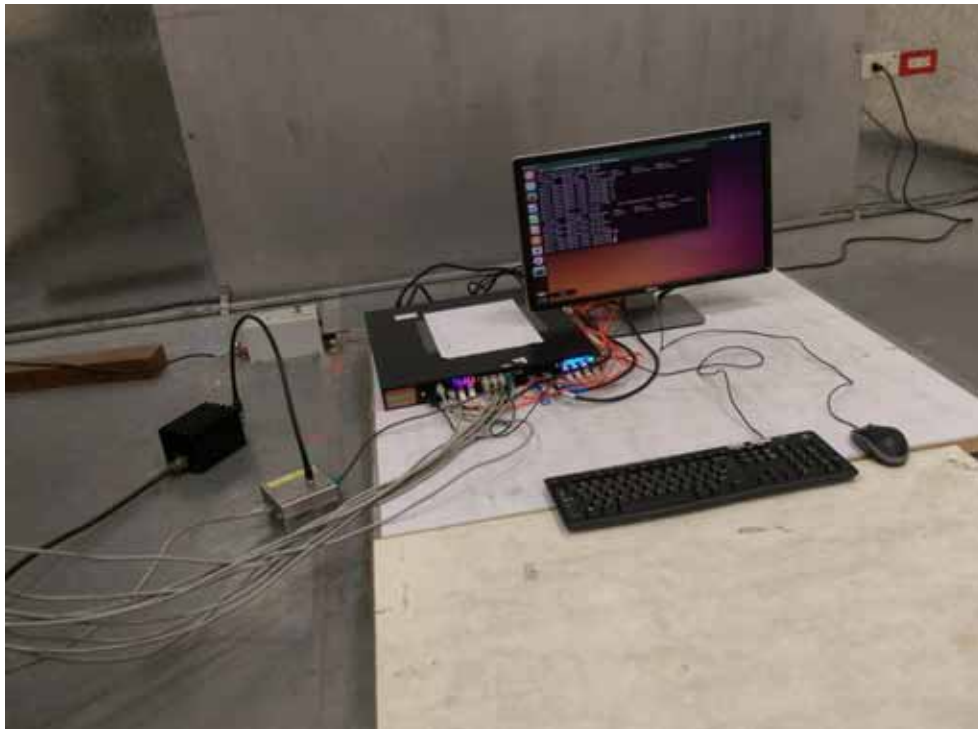

### Voltage Dips / Interruptions Test

