



EMC Test Report

Issued Date : May 03, 2010
Project No. : E1004052
Equipment : Flexible Embedded System
Model Name : xxxxFES-6110-xx-xxx-xxxxxxx (Where x is 0-9, A-Z, - or blank) for marketing purpose; xxxxFES-5120-xx-xxx-xxxxxxx (Where x is 0-9, A-Z, - or blank) for marketing purpose
Applicant : AAeon Technology Inc.
Address : 5F, No. 135, Lane 235, Pao Chiao Rd. Hsin-Tien City, Taipei, Taiwan, R.O.C.

Tested by: Neutron Engineering Inc. EMC Laboratory
Date of Receipt: Apr. 13, 2010
Date of Test: Apr. 13, 2010 ~ Apr. 27, 2010

Testing Engineer: Peter Li
(Peter Li)

Technical Manager: Jeff Yang
(Jeff Yang)

Authorized Signatory: Andy Chiu
(Andy Chiu)

Neutron Engineering Inc.
B1, No. 37, Lane 365, YangGuang St.,
NeiHu District 114, Taipei, Taiwan.
TEL: +886-2-2657-3299
FAX: +886-2-2657-3331





Declaration

Neutron represents to the client that testing is done in accordance with standard procedures as applicable and that test instruments used has been calibrated with the standards traceable to National Measurement Laboratory (**NML**) of **R.O.C.**, or National Institute of Standards and Technology (**NIST**) of **U.S.A.**

Neutron's reports apply only to the specific samples tested under conditions. It is manufacture's responsibility to ensure that additional production units of this model are manufactured with the identical electrical and mechanical components. **Neutron** shall have no liability for any declarations, inferences or generalizations drawn by the client or others from **Neutron** issued reports.

Neutron's reports must not be used by the client to claim product endorsement by the authorities or any agency of the Government.

This report is the confidential property of the client. As a mutual protection to the clients, the public and **Neutron-self**, extracts from the test report shall not be reproduced except in full with **Neutron's** authorized written approval.

Neutron's laboratory quality assurance procedures are in compliance with the **ISO Guide 17025** requirements, and accredited by the conformity assessment authorities listed in this test report.

Limitation

For the use of the authority's logo is limited unless the Test Standard(s)/Scope(s)/Item(s) mentioned in this test report is (are) included in the conformity assessment authorities acceptance respective.



Table of Contents	Page
1 . CERTIFICATION	6
2 . SUMMARY OF TEST RESULTS	7
2.1 TEST FACILITY	8
2.2 MEASUREMENT UNCERTAINTY	8
3 . GENERAL INFORMATION	9
3.1 GENERAL DESCRIPTION OF EUT	9
3.2 DESCRIPTION OF TEST MODES	10
3.3 BLOCK DIAGRAM SHOWING THE CONFIGURATION OF SYSTEM TESTED	11
3.4 DESCRIPTION OF SUPPORT UNITS	12
4 . EMC EMISSION TEST	13
4.1 CONDUCTED EMISSION MEASUREMENT	13
4.1.1 POWER LINE CONDUCTED EMISSION	13
4.1.2 MEASUREMENT INSTRUMENTS LIST	13
4.1.3 TEST PROCEDURE	14
4.1.4 DEVIATION FROM TEST STANDARD	14
4.1.5 TEST SETUP	14
4.1.6 EUT OPERATING CONDITIONS	15
4.1.7 TEST RESULTS	16
4.2 CONDUCTED EMISSION MEASUREMENT AT TELECOMMUNICATION PORTS	18
4.2.1 LIMITS OF DISTURBANCE AT TELECOMMUNICATION PORTS	18
4.2.2 MEASUREMENT INSTRUMENTS LIST	18
4.2.3 TEST PROCEDURE	19
4.2.4 DEVIATION FROM TEST STANDARD	19
4.2.5 TEST SETUP	19
4.2.6 EUT OPERATING CONDITIONS	19
4.2.7 TEST RESULTS	20
4.3 RADIATED EMISSION MEASUREMENT	23
4.3.1 LIMITS OF RADIATED EMISSION MEASUREMENT	23
4.3.2 MEASUREMENT INSTRUMENTS LIST	24
4.3.3 TEST PROCEDURE	24
4.3.4 DEVIATION FROM TEST STANDARD	24
4.3.5 TEST SETUP	25
4.3.6 EUT OPERATING CONDITIONS	25
4.3.7 TEST RESULTS-BETWEEN 30MHZ AND 1000MHZ	26
4.3.8 TEST RESULTS-ABOVE 1000MHZ	28
4.4 HARMONICS CURRENT MEASUREMENT	30
4.4.1 LIMITS OF HARMONICS CURRENT MEASUREMENT	30



Table of Contents	Page
4.4.2 MEASUREMENT INSTRUMENTS LIST	30
4.4.3 TEST PROCEDURE	31
4.4.4 DEVIATION FROM TEST STANDARD	31
4.4.5 TEST SETUP	31
4.4.6 EUT OPERATING CONDITIONS	31
4.4.7 TEST RESULTS	32
4.5 VOLTAGE FLUCTUATION AND FLICKERS MEASUREMENT	35
4.5.1 LIMITS OF VOLTAGE FLUCTUATION AND FLICKERS MEASUREMENT	35
4.5.2 MEASUREMENT INSTRUMENTS LIST	35
4.5.3 TEST PROCEDURE	35
4.5.4 DEVIATION FROM TEST STANDARD	35
4.5.5 TESTSETUP	36
4.5.6 EUT OPERATING CONDITIONS	36
4.5.7 TEST RESULTS	37
5 . EMC IMMUNITY TEST	38
5.1 STANDARD COMPLIANCE/SERVIRTY LEVEL/CRITERIA	38
5.2 GENERAL PERFORMANCE CRITERIA	39
5.3 GENERAL PERFORMANCE CRITERIA TEST SETUP	39
5.4 ESD TESTING	40
5.4.1 TEST SPECIFICATION	40
5.4.2 MEASUREMENT INSTRUMENTS	40
5.4.3 TEST PROCEDURE	40
5.4.4 DEVIATION FROM TEST STANDARD	41
5.4.5 TEST SETUP	41
5.4.6 TEST RESULTS	42
5.4.7 PHOTO(S) SHOWN THE LOCATION(S) OF ESD EVALUATED	43
5.5 RS TESTING	44
5.5.1 TEST SPECIFICATION	44
5.5.2 MEASUREMENT INSTRUMENTS	44
5.5.3 TEST PROCEDURE	44
5.5.4 DEVIATION FROM TEST STANDARD	44
5.5.5 TEST SETUP	45
5.5.6 TEST RESULTS	46
5.6 EFT/BURST TESTING	47
5.6.1 TEST SPECIFICATION	47
5.6.2 MEASUREMENT INSTRUMENTS	47
5.6.3 TEST PROCEDURE	47
5.6.4 DEVIATION FROM TEST STANDARD	47
5.6.5 TEST SETUP	48
5.6.6 TEST RESULTS	49
5.7 SURGE TESTING	50



Table of Contents	Page
5.7.1 TEST SPECIFICATION	50
5.7.2 MEASUREMENT INSTRUMENTS	50
5.7.3 TEST PROCEDURE	50
5.7.4 DEVIATION FROM TEST STANDARD	51
5.7.5 TEST SETUP	51
5.7.6 TEST RESULTS	52
5.8 INJECTION CURRENT TESTING	53
5.8.1 TEST SPECIFICATION	53
5.8.2 MEASUREMENT INSTRUMENTS	53
5.8.3 TEST PROCEDURE	53
5.8.4 DEVIATION FROM TEST STANDARD	53
5.8.5 TEST SETUP	54
5.8.6 TEST RESULTS	55
5.9 POWER FREQUENCY MAGNETIC FIELD TESTING	56
5.9.1 TEST SPECIFICATION	56
5.9.2 MEASUREMENT INSTRUMENTS	56
5.9.3 TEST PROCEDURE	56
5.9.4 DEVIATION FROM TEST STANDARD	56
5.9.5 TEST SETUP	57
5.9.6 TEST RESULTS	58
5.10 VOLTAGE INTERRUPTION/DIPS TESTING	59
5.10.1 TEST SPECIFICATION	59
5.10.2 MEASUREMENT INSTRUMENTS	59
5.10.3 TEST PROCEDURE	59
5.10.4 DEVIATION FROM TEST STANDARD	59
5.10.5 TEST SETUP	60
5.10.6 TEST RESULTS	61
6 . EUT TEST PHOTO	62



1. CERTIFICATION

Equipment : Flexible Embedded System

Brand Name : AAEON

Model Name : xxxxFES-6110-xx-xxx-xxxxxxx (Where x is 0-9, A-Z, - or blank) for marketing purpose; xxxxFES-5120-xx-xxx-xxxxxxx (Where x is 0-9, A-Z, - or blank) for marketing purpose

Applicant : AAEON Technology Inc.

Date of Test : Apr. 13, 2010 ~ Apr. 27, 2010

Standards : EN 55022: 2006 +A1: 2007 Class A

EN 61000-3-2: 2006 Class D

EN 61000-3-3: 1995 +A1: 2001 +A2: 2005

EN 55024: 1998 +A1: 2001 +A2: 2003

IEC 61000-4-2: 2001

IEC 61000-4-3: 2006

IEC 61000-4-4: 2004

IEC 61000-4-5: 2005

IEC 61000-4-6: 2006

IEC 61000-4-8: 2001

IEC 61000-4-11: 2004

The above equipment has been tested and found compliance with the requirement of the relative standards by Neutron Engineering Inc. EMC Laboratory.

The test data, data evaluation, and equipment configuration contained in our test report (Ref No. NEI-EMC-1-E1004052) were obtained utilizing the test procedures, test instruments, test sites that has been accredited by the Authority of NVLAP and TAF according to the ISO-17025 quality assessment standard and technical standard(s).



2. SUMMARY OF TEST RESULTS

Test procedures according to the technical standards:

Emission				
Standard	Test Item	Limit	Judgment	Remark
EN 55022: 2006 +A1: 2007	Conducted Emission	Class A	PASS	
	Conducted Emission At Telecommunication Ports	Class A	PASS	
	Radiated Emission	Class A	PASS	
EN 61000-3-2: 2006	Harmonic Current Emission	Class D	PASS	NOTE (2)
EN 61000-3-3:1995 +A1: 2001 +A2: 2005	Voltage Fluctuations & Flicker	-----	PASS	
Immunity				
EN 55024:1998 +A1: 2001 +A2: 2003				
Section	Test Item	Performance Criteria	Judgment	Remark
IEC 61000-4-2: 2001	Electrostatic Discharge	B	PASS	
IEC 61000-4-3: 2006	RF electromagnetic field	A	PASS	
IEC 61000-4-4: 2004	Fast transients	B	PASS	
IEC 61000-4-5: 2005	Surges	B	PASS	
IEC 61000-4-6: 2006	Injected Current	A	PASS	
IEC 61000-4-8: 2001	Power Frequency Magnetic Field	A	PASS	
IEC 61000-4-11: 2004	Volt. Interruptions Volt. Dips	B / C / C NOTE (3)	PASS	

NOTE:

- (1) " N/A" denotes test is not applicable in this Test Report.
- (2) The power consumption of EUT is less than 75W and no Limits apply.
- (3) Voltage dip: >95% reduction – Performance Criteria **B**
 Voltage dip: 30% reduction – Performance Criteria **C**
 Voltage Interruption: >95% reduction – Performance Criteria **C**
- (4) For client's request and manual description, the test will not be executed.



2.1 TEST FACILITY

The test facilities used to collect the test data in this report is **C01/OS02/CB08** at the location of No.132-1, Lane 329, Sec. 2, Palian Road, Shijr City, Taipei, Taiwan.

2.2 MEASUREMENT UNCERTAINTY

The reported uncertainty of measurement $y \pm U$, where expanded uncertainty **U** is based on a standard uncertainty multiplied by a coverage factor of **k=2**, providing a level of confidence of approximately **95%**.

The measurement instrumentation uncertainty considerations contained in CISPR 16-4-2.

A. Conducted Measurement :

Test Site	Method	Measurement Frequency Range	U , (dB)	NOTE
C01	ANSI	150 KHz ~ 30MHz	1.94	

B. Radiated Measurement :

Test Site	Method	Measurement Frequency Range	Ant. H / V	U , (dB)	NOTE
OS-01	ANSI	30MHz ~ 200MHz	V	2.86	
		30MHz ~ 200MHz	H	2.56	
		200MHz ~ 1,000MHz	V	2.88	
		200MHz ~ 1,000MHz	H	2.98	
OS-02	ANSI	30MHz ~ 200MHz	V	2.48	
		30MHz ~ 200MHz	H	2.16	
		200MHz ~ 1,000MHz	V	2.50	
		200MHz ~ 1,000MHz	H	2.66	

Our calculated Measurement Instrumentation Uncertainty is shown in the tables above. These are our U_{lab} values in CISPR 16-4-2 terminology.

Since Table 1 of CISPR 16-4-2 has values of measurement instrumentation uncertainty, called U_{CISPR} , as follows:

Conducted Disturbance (mains port) – 150 kHz – 30 MHz : 3.6 dB

Radiated Disturbance (electric field strength on an open area test site or alternative test site) – 30 MHz – 1000 MHz : 5.2 dB

It can be seen that our U_{lab} values are smaller than U_{CISPR} .



3. GENERAL INFORMATION

3.1 GENERAL DESCRIPTION OF EUT

Equipment	Flexible Embedded System
Brand Name	AAEON
Model Name	xxxxFES-6110-xx-xxx-xxxxxxx (Where x is 0-9, A-Z, - or blank) for marketing purpose; xxxxFES-5120-xx-xxx-xxxxxxx (Where x is 0-9, A-Z, - or blank) for marketing purpose
OEM Brand/Model Name	N/A
Model Difference	Model xxxxFES-5120-xx-xxx-xxxxxxx is electrically the same as model xxxxFES-6110-xx-xxx-xxxxxxx. The only difference between the two models is I/O Port designation. (Please refer to the EUT Photo.) Model xxxxFES-6110-xx-xxx-xxxxxxx; xxxxFES-5120-xx-xxx-xxxxxxx, 0-9, A-Z, - or blank) for marketing purpose. Models' differences between each other only the changes of model name which do not affect the EMI performance. All the above models were tested, and the model: FES-6110 was found to be the worst case during the pr-scanning test. This model of the worst case was used for final testing and collecting test data included in this report.
Product Description	The EUT is a Flexible Embedded System. Based on the application, features, or specification exhibited in User's Manual, the EUT is considered as an ITE/Computing Device. More details of EUT technical specification, please refer to the User's Manual.
Power Source	DC Voltage supplied from AC/DC adapter.
Power Rating	I/P: AC 100-240V~1.5A, 50-60Hz / O/P: DC 12V, 5.0A MAX (60W MAX)
Connecting I/O Port(s)	Please refer to the User's Manual
Products Covered	Main Board: xxxxIMBE-945Gxx-xxx-xxxxxxx (Where x is 0-9, A-Z, - or blank) for marketing purpose CPU: Intel N270 1.6GHz/512/533 RAM: DSL 1GB/DDR2/667 HDD: Fujitsu 80GB MHZ2080BH G2 Adapter: FSP FSP060-DBAB1
EUT Modification(s)	N/A

Note:

1. For a more detailed features description, please refer to the manufacturer's specifications or the User's Manual.



3.2 DESCRIPTION OF TEST MODES

To investigate the maximum EMI emission characteristics generates from EUT, the test system was pre-scanning tested base on the consideration of following EUT operation mode or test configuration mode which possible have effect on EMI emission level. Each of these EUT operation mode(s) or test configuration mode(s) mentioned above was evaluated respectively.

Pretest Test Mode	Description
Mode 1	FULL SYSTEM D-SUB+DVI 1600*1200/60Hz (FES-6110)
Mode 2	FULL SYSTEM D-SUB+DVI 1600*1200/60Hz (FES-5120)

For Conducted Test	
Final Test Mode	Description
Mode 1	FULL SYSTEM D-SUB+DVI 1600*1200/60Hz (FES-6110)

For ISN Test	
Final Test Mode	Description
Mode 1	FULL SYSTEM D-SUB+DVI 1600*1200/60Hz (FES-6110) (ETHERNET 1G-1G)
Mode 1	FULL SYSTEM D-SUB+DVI 1600*1200/60Hz (FES-6110) (ETHERNET 100M-100M)
Mode 1	FULL SYSTEM D-SUB+DVI 1600*1200/60Hz (FES-6110) (ETHERNET 10M-10M)

For Radiated Test	
Final Test Mode	Description
Mode 1	FULL SYSTEM D-SUB+DVI 1600*1200/60Hz (FES-6110)

For Harmonics / Flicks Test	
Final Test Mode	Description
Mode 1	FULL SYSTEM D-SUB+DVI 1600*1200/60Hz (FES-6110)

For EMS Test	
Final Test Mode	Description
Mode 1	FULL SYSTEM D-SUB+DVI 1600*1200/60Hz (FES-6110)



3.3 BLOCK DIAGRAM SHOWING THE CONFIGURATION OF SYSTEM TESTED

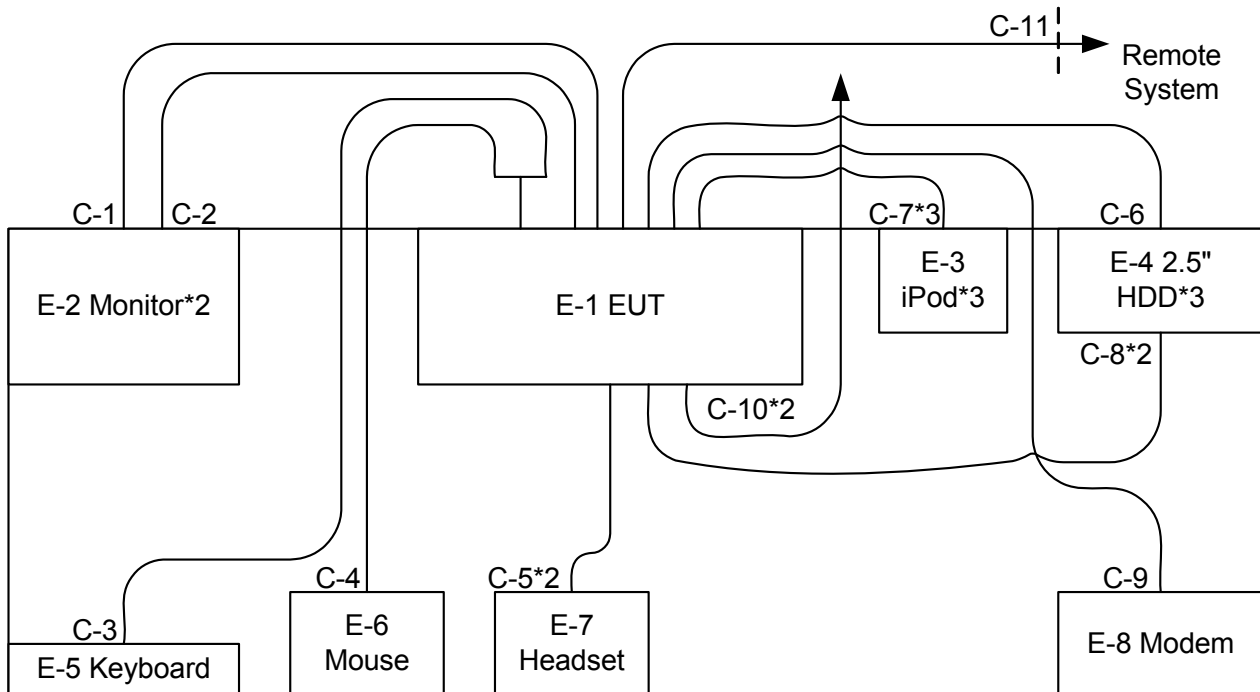

- C-1 DVI Cable
- C-2 D-Sub Cable
- C-3 PS/2 Cable
- C-4 PS/2 Cable
- C-5 Audio Cable
- C-6 USB Cable
- C-7 USB Cable
- C-8 USB Cable
- C-9 RS232 Cable
- C-10 Power Cable
- C-11 RJ-45 Cable



3.4 DESCRIPTION OF SUPPORT UNITS

The EUT has been tested as an independent unit together with other necessary accessories or support units. The following support units or accessories were used to form a representative test configuration during the tests.

Item	Equipment	Mfr/Brand	Model/Type No.	FCC ID	Series No.	Note
E-1	Flexible Embedded System	AAEON	FES-6110	N/A	N/A	EUT
E-2	24" LCD Monitor	DELL	2408WFPb	DOC	071863-11	
E-3	iPod nano	Apple	A1137	DOC	YM63604QUPR	
E-4	2.5" Mobile External HDD	FireWire	F12-UF	DOC	N/A	
E-5	PS/2 K/B	Logitech	Y-SJ17(ACK260A)	DOC	SYU44664880	
E-6	PS/2 Mouse	Logitech	M-SBF69	DOC	HCA44601156	
E-7	Headset	i-Acon	HOH-323-BK	N/A	N/A	
E-8	Modem	Intel	PCFM6501	EJMPCFM6501	306925-002	

Item	Shielded Type	Ferrite Core	Length	Note
C-1	YES	YES	1.8M	
C-2	YES	YES	1.8M	
C-3	YES	NO	1.7M	
C-4	YES	NO	1.9M	
C-5	NO	NO	1.8M	
C-6	YES	NO	1.8M	
C-7	YES	NO	1.0M	
C-8	YES	NO	1.8M	
C-9	YES	NO	1.7M	
C-10	NO	NO	1.0M	
C-11	NO	NO	10.0M	

Note:

- (1) The support equipment was authorized by Declaration of Conformity.
- (2) For detachable type I/O cable should be specified the length in cm in 『Length』 column.



4. EMC EMISSION TEST

4.1 CONDUCTED EMISSION MEASUREMENT

4.1.1 POWER LINE CONDUCTED EMISSION (FREQUENCY RANGE 150KHZ-30MHZ)

FREQUENCY (MHz)	Class A (dBuV)		Class B (dBuV)	
	Quasi-peak	Average	Quasi-peak	Average
0.15 -0.5	79.00	66.00	66 - 56 *	56 - 46 *
0.50 -5.0	73.00	60.00	56.00	46.00
5.0 -30.0	73.00	60.00	60.00	50.00

Note:

- (1) The tighter limit applies at the band edges.
- (2) The limit of " * " marked band means the limitation decreases linearly with the logarithm of the frequency in the range.

4.1.2 MEASUREMENT INSTRUMENTS LIST

Item	Kind of Equipment	Manufacturer	Type No.	Serial No.	Calibrated until
1	LISN	EMCO	3816/2	00042991	Feb. 7, 2011
2	Test Cable	N/A	SR03_C_01 &02	N/A	Aug. 19, 2010
3	Pulse Limiter	Electro-Metrics	EM-7600	112644	Dec. 27, 2010
4	EMI Test Receiver	R&S	ESCI	100082	Mar. 16, 2011
5	50Ω BNC TYPE Terminator	N/A	N/A	01	May 25, 2011
6	50Ω BNC TYPE Terminator	N/A	N/A	03	May 25, 2011
7	LISN	EMCO	4825/2	00028234	Jul. 13, 2010

Remark: " N/A" denotes No Model Name , Serial No. or No Calibration specified.

4.1.3 TEST PROCEDURE

- a. The EUT was placed 0.8 meters from the horizontal ground plane with EUT being connected to the power mains through a line impedance stabilization network (LISN). All other support equipments powered from additional LISN(s). The LISN provide 50 Ohm/ 50uH of coupling impedance for the measuring instrument.
- b. Interconnecting cables that hang closer than 40 cm to the ground plane shall be folded back and forth in the center forming a bundle 30 to 40 cm long.
- c. I/O cables that are not connected to a peripheral shall be bundled in the center. The end of the cable may be terminated, if required, using the correct terminating impedance. The overall length shall not exceed 1 m.
- d. LISN at least 80 cm from nearest part of EUT chassis.
- e. For the actual test configuration, please refer to the related Item –EUT Test Photos.

4.1.4 DEVIATION FROM TEST STANDARD

No deviation

4.1.5 TEST SETUP

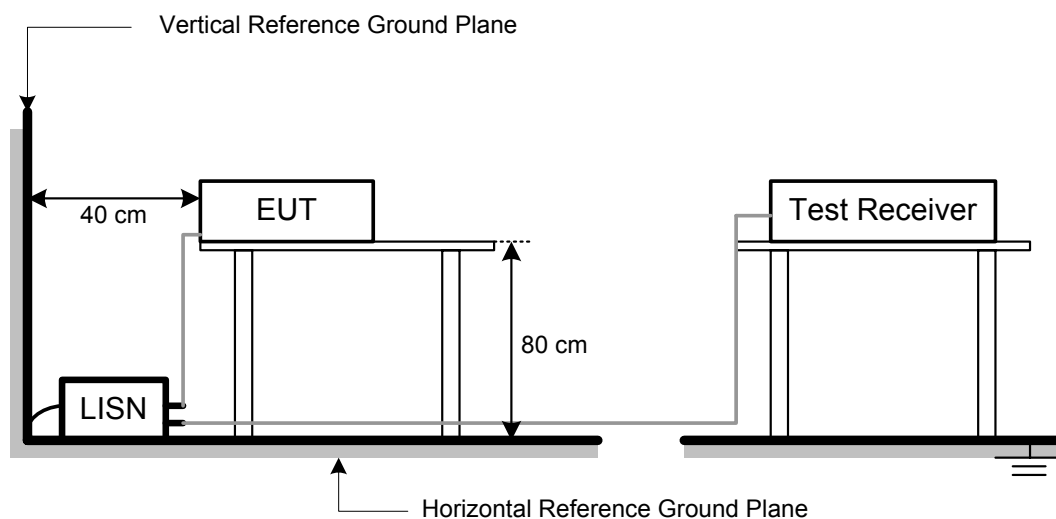



4.1.6 EUT OPERATING CONDITIONS

The EUT exercise program (EMC.exe) used during radiated and/or conducted emission measurement was designed to exercise the various system components in a manner similar to a typical use. The program contained on a PC hard disk and is auto-starting on power-up. Once loaded, the program sequentially exercises each system component in turn. The sequence used is:

1. Read (write) from (to) mass storage device (iPod & External HDD).
2. Send "H" pattern to video port device (Monitor).
3. Send " H " pattern to serial port device (Modem).
4. Send/Receive data to/from remote system.
5. Send/Receive audio to/from audio devices.
6. Repeated from 2 to 5 continuously.

As the keyboard and mouse are strictly input devices, no data is transmitted to (from) them during test. They are, however, continuously scanned for data input activity.



4.1.7 TEST RESULTS

E.U.T :	Flexible Embedded System	Model Name :	FES-6110
Temperature :	24 °C	Relative Humidity :	51%
Test Voltage :	AC 230V/50Hz		
Test Mode :	FULL SYSTEM D-SUB+DVI 1600*1200/60Hz (FES-6110)		

Freq. (MHz)	Terminal L/N	Measured(dBuV)		Limits(dBuV)		Margin (dB)	Note
		QP-Mode	AV-Mode	QP-Mode	AV-Mode		
0.15	Line	52.34	*	79.00	66.00	-26.66	(QP)
0.28	Line	52.47	*	79.00	66.00	-26.53	(QP)
0.34	Line	45.01	*	79.00	66.00	-33.99	(QP)
0.41	Line	41.18	*	79.00	66.00	-37.82	(QP)
5.60	Line	34.69	*	73.00	60.00	-38.31	(QP)
18.10	Line	38.00	*	73.00	60.00	-35.00	(QP)

Remark

- (1) Reading in which marked as QP means measurements by using are Quasi-Peak Mode with Detector BW=9KHz; SPA setting in RBW=10KHz,VBW =10KHz, Swp. Time = 0.2 sec./MHz ◦ Reading in which marked as AV means measurements by using are Average Mode with instrument setting in RBW=10KHz,VBW=10KHz, Swp. Time =0.2 sec./MHz ◦
- (2) All readings are QP Mode value unless otherwise stated AVG in column of 'Note'. If the QP Mode Measured value compliance with the QP Limits and lower than AVG Limits, the EUT shall be deemed to meet both QP & AVG Limits and then only QP Mode was measured, but AVG Mode didn't perform ◦ In this case, a " * " marked in AVG Mode column of Interference Voltage Measured ◦
- (3) Measuring frequency range from 150KHz to 30MHz ◦

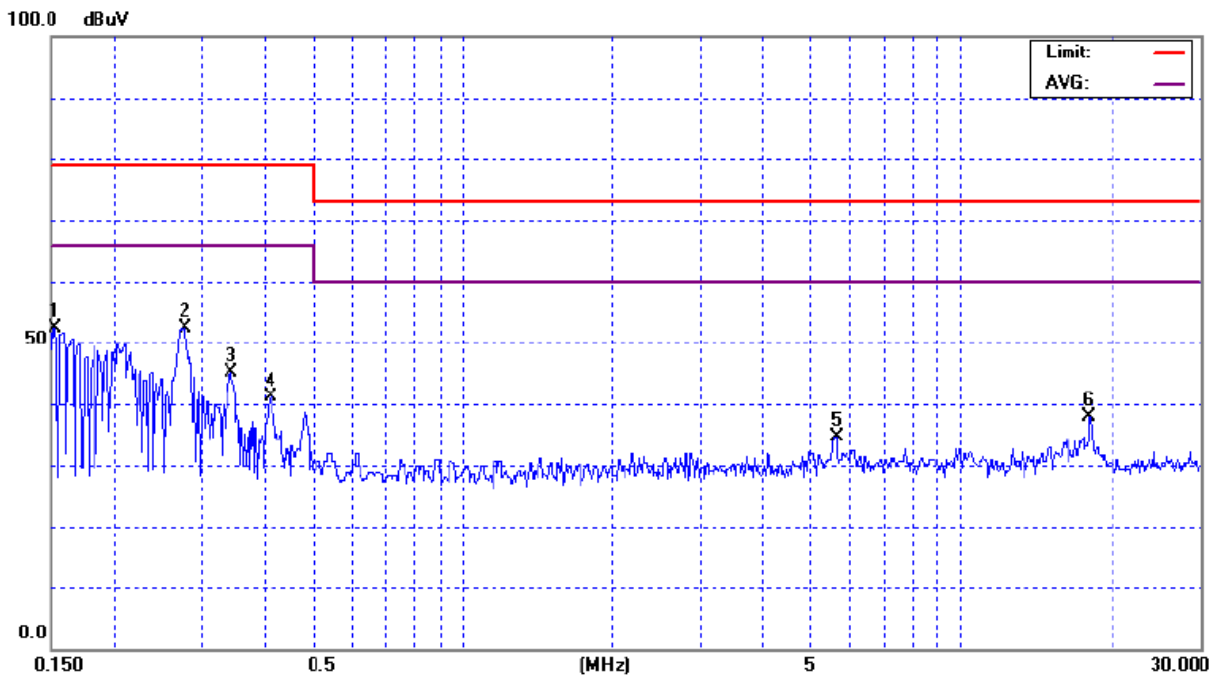



E.U.T :	Flexible Embedded System	Model Name :	FES-6110
Temperature :	24 °C	Relative Humidity :	51%
Test Voltage :	AC 230V/50Hz		
Test Mode :	FULL SYSTEM D-SUB+DVI 1600*1200/60Hz (FES-6110)		

Freq. (MHz)	Terminal L/N	Measured(dBuV)		Limits(dBuV)		Margin (dB)	Note
		QP-Mode	AV-Mode	QP-Mode	AV-Mode		
0.15	Neutral	51.97	*	79.00	66.00	-27.03	(QP)
0.21	Neutral	49.17	*	79.00	66.00	-29.83	(QP)
0.27	Neutral	52.26	*	79.00	66.00	-26.74	(QP)
0.35	Neutral	44.71	*	79.00	66.00	-34.29	(QP)
0.41	Neutral	40.16	*	79.00	66.00	-38.84	(QP)
17.50	Neutral	43.49	*	73.00	60.00	-29.51	(QP)

Remark

- (1) Reading in which marked as QP means measurements by using are Quasi-Peak Mode with Detector BW=9KHz; SPA setting in RBW=10KHz,VBW =10KHz, Swp. Time = 0.2 sec./MHz ◦
 Reading in which marked as AV means measurements by using are Average Mode with instrument setting in RBW=10KHz,VBW=10KHz, Swp. Time =0.2 sec./MHz ◦
- (2) All readings are QP Mode value unless otherwise stated AVG in column of 'Note'. If the QP Mode Measured value compliance with the QP Limits and lower than AVG Limits, the EUT shall be deemed to meet both QP & AVG Limits and then only QP Mode was measured, but AVG Mode didn't perform ◦ In this case, a " * " marked in AVG Mode column of Interference Voltage Measured ◦
- (3) Measuring frequency range from 150KHz to 30MHz ◦

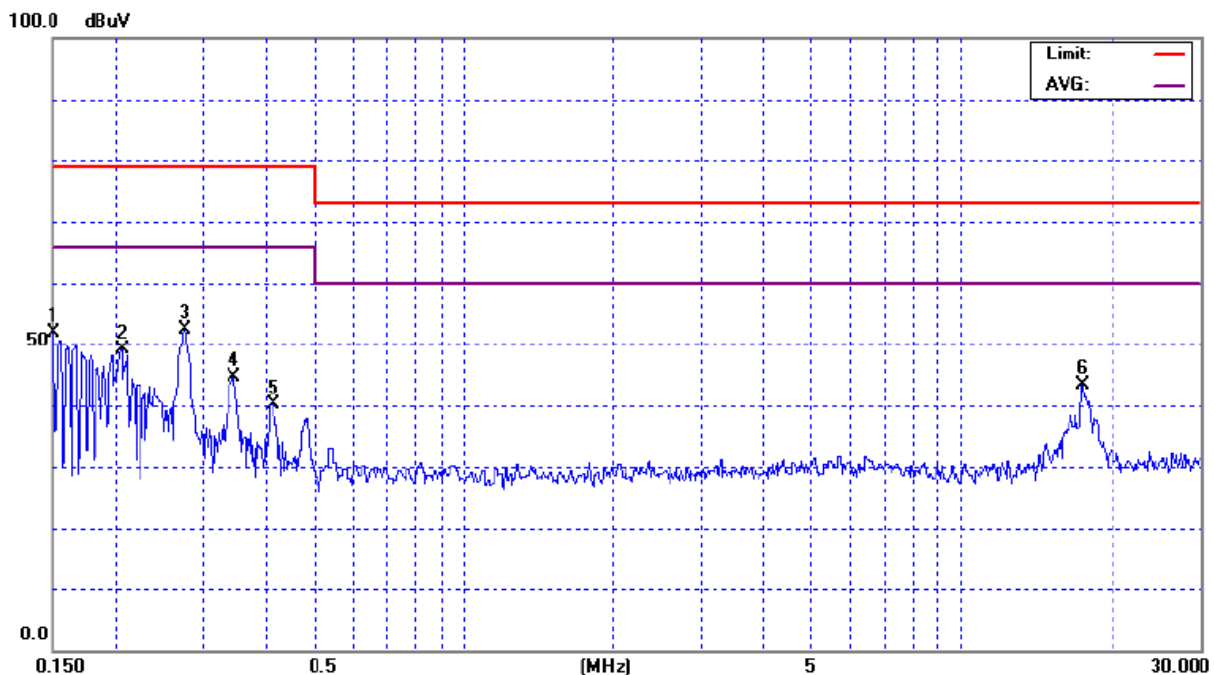



4.2 CONDUCTED EMISSION MEASUREMENT AT TELECOMMUNICATION PORTS

4.2.1 LIMITS OF DISTURBANCE AT TELECOMMUNICATION PORTS

Voltage Limit:

FREQUENCY (MHz)	Class A (dBuV)		Class B (dBuV)	
	Quasi-peak	Average	Quasi-peak	Average
0.15 -0.5	97-87*	84-74*	87-74*	74-64*
0.5 -30.0	87	74	74	64

Current Limit:

FREQUENCY (MHz)	Class A (dBuA)		Class B (dBuA)	
	Quasi-peak	Average	Quasi-peak	Average
0.15 -0.5	53-43*	40-30*	40-30*	30-20*
0.5 -30.0	43	30	30	20

Note:

- (1) The tighter limit applies at the band edges.
- (2) The limit of " * " marked band means the limitation decreases linearly with the logarithm of the frequency in the range.

4.2.2 MEASUREMENT INSTRUMENTS LIST

Item	Kind of Equipment	Manufacturer	Type No.	Serial No.	Calibrated until
1	LISN	EMCO	3816/2	00042991	Feb. 7, 2011
2	Test Cable	N/A	SR03_C_01 &02	N/A	Aug. 19, 2010
3	Pulse Limiter	Electro-Metrics	EM-7600	112644	Dec. 27, 2010
4	EMI Test Receiver	R&S	ESCI	100082	Mar. 16, 2011
5	50Ω BNC TYPE Terminator	N/A	N/A	01	May 25, 2011
6	50Ω BNC TYPE Terminator	N/A	N/A	03	May 25, 2011
7	LISN	EMCO	4825/2	00028234	Jul. 13, 2010
8	ISN	FCC	FCC-TLISN-T4-02	20431	Jul.12, 2010
9	ISN	FCC	FCC-TLISN-T8-02	20432	Jul.12, 2010

Remark: " N/A " denotes No Model Name , Serial No. or No Calibration specified.

4.2.3 TEST PROCEDURE

- a. The EUT was placed 0.4 meters from the horizontal ground plane with EUT being connected to the power mains through a line impedance stabilization network (LISN). All other support equipments powered from additional LISN(s). The LISN provide 50 Ohm/ 50uH of coupling impedance for the measuring instrument.
- b. Interconnecting cables that hang closer than 40 cm to the ground plane shall be folded back and forth in the center forming a bundle 30 to 40 cm long.
- c. I/O cables that are not connected to a peripheral shall be bundled in the center. The end of the cable may be terminated, if required, using the correct terminating impedance. The overall length shall not exceed 1 m.
- d. ISN at least 80 cm from nearest part of EUT chassis.
- e. The communication function of EUT was executed and ISN was connected between EUT and associated equipment and the ISN was connected directly to reference ground plane.
- f. For the actual test configuration, please refer to the related Item –EUT Test Photos.

4.2.4 DEVIATION FROM TEST STANDARD

No deviation

4.2.5 TEST SETUP

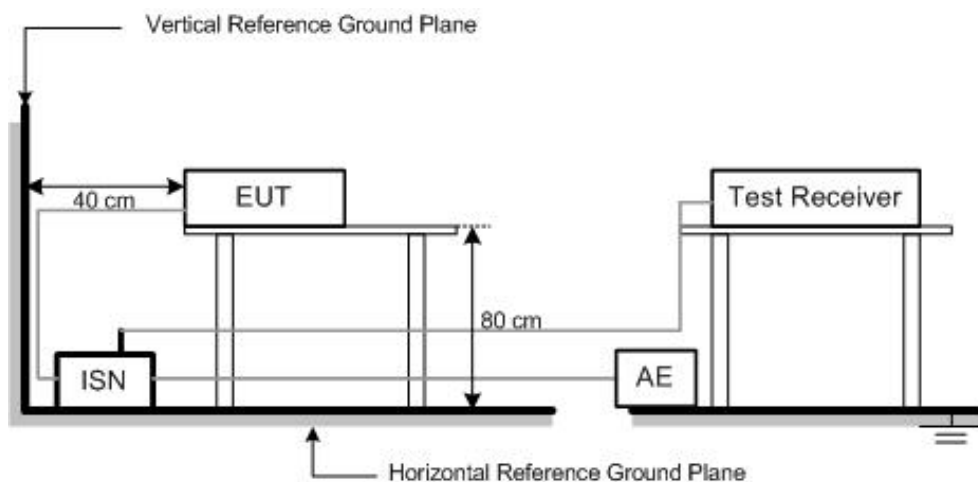

4.2.6 EUT OPERATING CONDITIONS

The EUT tested system was configured as the statements of 4.1.6 Unless otherwise a special operating condition is specified in the follows during the testing.



4.2.7 TEST RESULTS

E.U.T :	Flexible Embedded System	Model Name :	FES-6110
Temperature :	24 °C	Relative Humidity :	51%
Test Voltage :	AC 230V/50Hz		
Test Mode :	FULL SYSTEM D-SUB+DVI 1600*1200/60Hz (FES-6110) (ETHERNET 1G-1G)		

Freq. (MHz)	Measured(dBuV)		Limits(dBuV)		Safe Margins	
	QP-Mode	AV-Mode	QP-Mode	AV-Mode	(dBuV)	Note
0.48	59.48	*	87.33	74.33	-27.85	(QP)
0.96	58.00	*	87.00	74.00	-29.00	(QP)
1.23	58.17	*	87.00	74.00	-28.83	(QP)
1.78	55.86	*	87.00	74.00	-31.14	(QP)
3.70	51.00	*	87.00	74.00	-36.00	(QP)
5.75	50.94	*	87.00	74.00	-36.06	(QP)

Remark

- (1) Reading in which marked as QP means measurements by using are Quasi-Peak Mode with Detector BW=9KHz; SPA setting in RBW=10KHz,VBW =10KHz, Swp. Time = 0.2 sec./MHz ◦
Reading in which marked as AV means measurements by using are Average Mode with instrument setting in RBW=10KHz,VBW=10KHz, Swp. Time =0.2 sec./MHz ◦
- (2) All readings are QP Mode value unless otherwise stated AVG in column of 'Note'. If the QP Mode Measured value compliance with the QP Limits and lower than AVG Limits, the EUT shall be deemed to meet both QP & AVG Limits and then only QP Mode was measured, but AVG Mode didn't perform ◦ In this case, a " * " marked in AVG Mode column of Interference Voltage Measured ◦
- (3) Measuring frequency range from 150KHz to 30MHz ◦

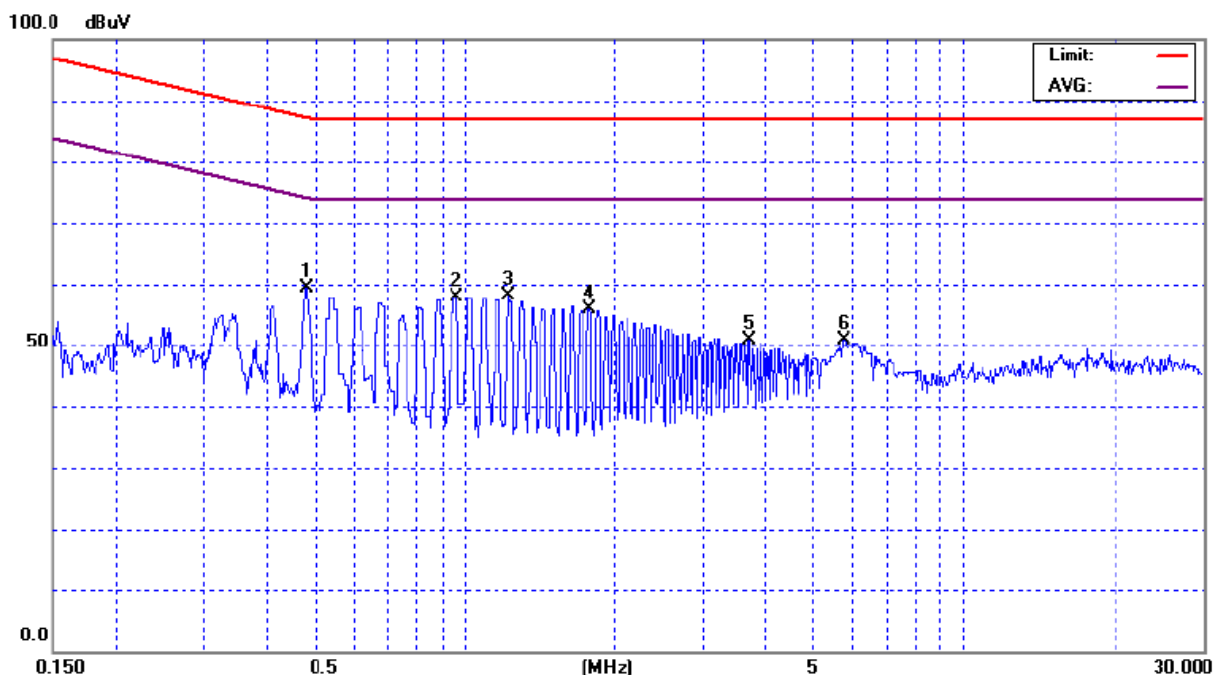



E.U.T :	Flexible Embedded System	Model Name :	FES-6110
Temperature :	24 °C	Relative Humidity :	51%
Test Voltage :	AC 230V/50Hz		
Test Mode :	FULL SYSTEM D-SUB+DVI 1600*1200/60Hz (FES-6110) (ETHERNET 100M-100M)		

Freq. (MHz)	Measured(dBuV)		Limits(dBuV)		Safe Margins	
	QP-Mode	AV-Mode	QP-Mode	AV-Mode	(dBuV)	Note
0.68	56.32	*	87.00	74.00	-30.68	(QP)
1.23	58.23	*	87.00	74.00	-28.77	(QP)
7.90	52.25	*	87.00	74.00	-34.75	(QP)
16.15	56.14	*	87.00	74.00	-30.86	(QP)
18.25	57.34	*	87.00	74.00	-29.66	(QP)
23.15	56.84	*	87.00	74.00	-30.16	(QP)

Remark

- (1) Reading in which marked as QP means measurements by using are Quasi-Peak Mode with Detector BW=9KHz; SPA setting in RBW=10KHz,VBW=10KHz, Swp. Time = 0.2 sec./MHz ◦ Reading in which marked as AV means measurements by using are Average Mode with instrument setting in RBW=10KHz,VBW=10KHz, Swp. Time =0.2 sec./MHz ◦
- (2) All readings are QP Mode value unless otherwise stated AVG in column of 'Note'. If the QP Mode Measured value compliance with the QP Limits and lower than AVG Limits, the EUT shall be deemed to meet both QP & AVG Limits and then only QP Mode was measured, but AVG Mode didn't perform ◦ In this case, a " * " marked in AVG Mode column of Interference Voltage Measured ◦
- (3) Measuring frequency range from 150KHz to 30MHz ◦

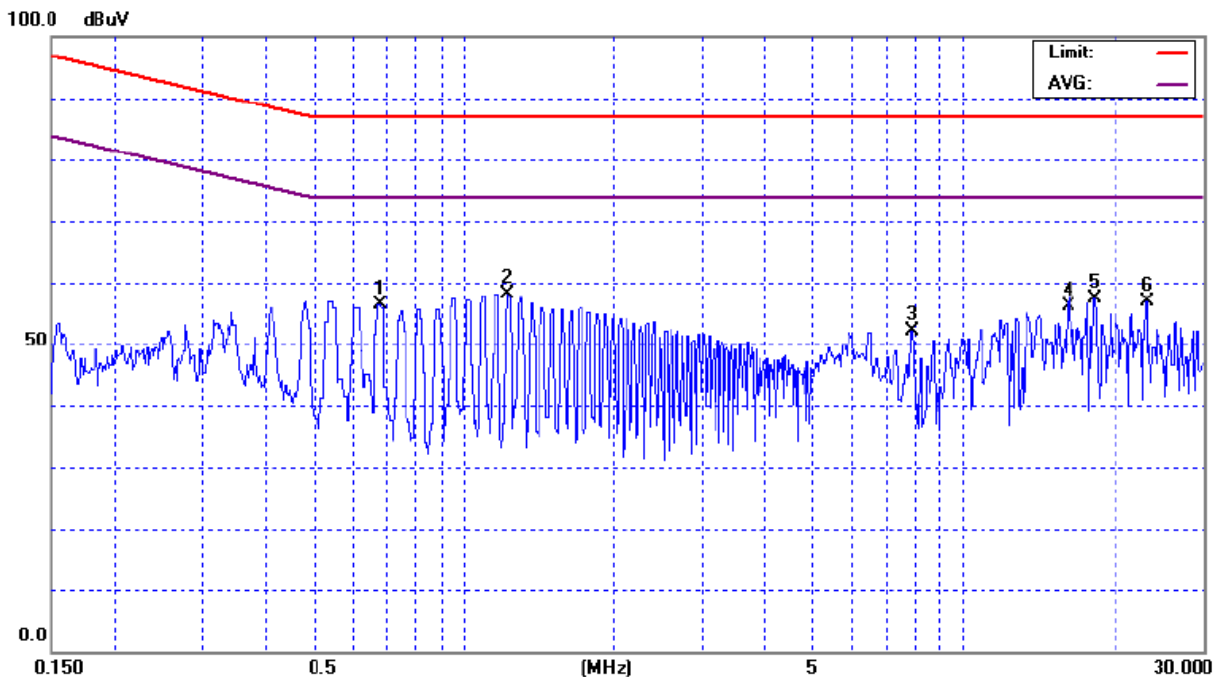



E.U.T :	Flexible Embedded System	Model Name :	FES-6110
Temperature :	24 °C	Relative Humidity :	51%
Test Voltage :	AC 230V/50Hz		
Test Mode :	FULL SYSTEM D-SUB+DVI 1600*1200/60Hz (FES-6110) (ETHERNET 10M-10M)		

Freq. (MHz)	Measured(dBuV)		Limits(dBuV)		Safe Margins	
	QP-Mode	AV-Mode	QP-Mode	AV-Mode	(dBuV)	Note
0.41	56.64	*	88.58	75.58	-31.94	(QP)
0.55	58.98	*	87.00	74.00	-28.02	(QP)
0.68	57.60	*	87.00	74.00	-29.40	(QP)
1.17	58.18	*	87.00	74.00	-28.82	(QP)
1.78	55.57	*	87.00	74.00	-31.43	(QP)
5.90	49.44	*	87.00	74.00	-37.56	(QP)

Remark

- (1) Reading in which marked as QP means measurements by using are Quasi-Peak Mode with Detector BW=9KHz; SPA setting in RBW=10KHz,VBW =10KHz, Swp. Time = 0.2 sec./MHz ◦ Reading in which marked as AV means measurements by using are Average Mode with instrument setting in RBW=10KHz,VBW=10KHz, Swp. Time =0.2 sec./MHz ◦
- (2) All readings are QP Mode value unless otherwise stated AVG in column of 'Note'. If the QP Mode Measured value compliance with the QP Limits and lower than AVG Limits, the EUT shall be deemed to meet both QP & AVG Limits and then only QP Mode was measured, but AVG Mode didn't perform ◦ In this case, a " * " marked in AVG Mode column of Interference Voltage Measured ◦
- (3) Measuring frequency range from 150KHz to 30MHz ◦

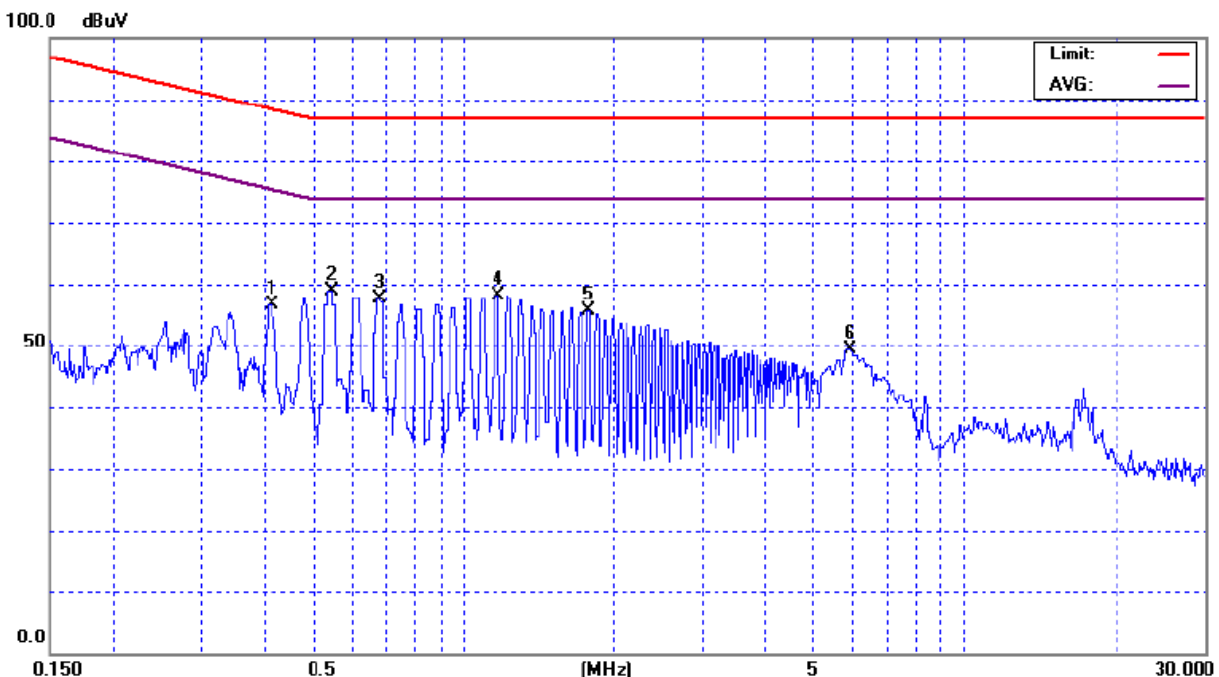



4.3 RADIATED EMISSION MEASUREMENT

4.3.1 LIMITS OF RADIATED EMISSION MEASUREMENT (BELOW 1000MHZ)

FREQUENCY (MHz)	Class A (at 10m)	Class B (at 10m)
	dBuV/m	dBuV/m
30 – 230	40	30
230 – 1000	47	37

Notes:

- (1) The limit for radiated test was performed according to as following:
CISPR 22/ FCC PART 15B /ICES-003.
- (2) The tighter limit applies at the band edges.
- (3) Emission level (dBuV/m)=20log Emission level (uV/m).

LIMITS OF RADIATED EMISSION MEASUREMENT (ABOVE 1000MHZ)

FREQUENCY (MHz)	Class A (dBuV/m) (at 3m)		Class B (dBuV/m) (at 3m)	
	PEAK	AVERAGE	PEAK	AVERAGE
1000-3000	76	56	70	50
3000-6000	80	60	74	54

Notes:

- (1) The lower limit applies at the transition frequency.

FREQUENCY RANGE OF RADIATED MEASUREMENT (FOR UNINTENTIONAL RADIATORS)

Highest frequency generated or Upper frequency of measurement used in the device or on which the device operates or tunes (MHz)	Range (MHz)
Below 108	1000
108 – 500	2000
500 – 1000	5000
Above 1000	5 th harmonic of the highest frequency or 6 GHz, whichever is lower



4.3.2 MEASUREMENT INSTRUMENTS LIST

Item	Kind of Equipment	Manufacturer	Type No.	Serial No.	Calibrated until
1	Log-Bicon Antenna	Schwarzbeck	VULB 9160	3173	Oct. 15, 2010
2	Pre-Amplifier	Anritsu	MH648A	M98457	Jan. 18, 2011
3	Test Cable	N/A	10M-OS01	N/A	Jun. 18, 2010
4	Test Cable	N/A	OS02	01	Jun. 23, 2010
5	EMI Test Receiver	R&S	ESCI	100082	Mar. 16, 2011
6	System Controller (OS02)	CT	SC100	N/A	N/A
7	Turn Table	Chance Most	CMTB-1.5	N/A	N/A
8	Horn Antenna	Schwarzbeck	BBHA 9120 D	9120D-546	May. 19, 2010
9	Microwave Pre amplifier	Agilent	8449B	3008A01714	Apr. 19, 2011
10	Microflex Cable	N/A	N/A	1m	May. 20, 2010
11	Microflex Cable	AISI	S104-SMAP-1	10m	Aug. 23, 2010
12	Microflex Cable	N/A	N/A	3m	Aug. 23, 2010
13	Spectrum Analyzer	R&S	FSP-40	100129	Sep. 10, 2010

Remark: " N/A" denotes No Model Name / Serial No. and No Calibration specified.

4.3.3 TEST PROCEDURE

- a. The measuring distance of at 10 m shall be used for measurements at frequency up to 1GHz. For frequencies above 1GHz, any suitable measuring distance may be used.
- b. The EUT was placed on the top of a rotating table 0.8 meters above the ground at a 3m or 10 meter open area test site. The table was rotated 360 degrees to determine the position of the highest radiation.
- c. The height of the equipment or of the substitution antenna shall be 0.8 m; the height of the test antenna shall vary between 1 m to 4 m. Both horizontal and vertical polarizations of the antenna are set to make the measurement.
- d. The initial step in collecting radiated emission data is a spectrum analyzer peak detector mode pre-scanning the measurement frequency range. Significant peaks are then marked and then Quasi Peak detector mode re-measured.
- e. If the Peak Mode measured value compliance with and lower than Quasi Peak Mode Limit, the EUT shall be deemed to meet QP Limits and then no additional QP Mode measurement performed.
- f. For the actual test configuration, please refer to the related Item –EUT Test Photos.

4.3.4 DEVIATION FROM TEST STANDARD

No deviation

4.3.5 TEST SETUP

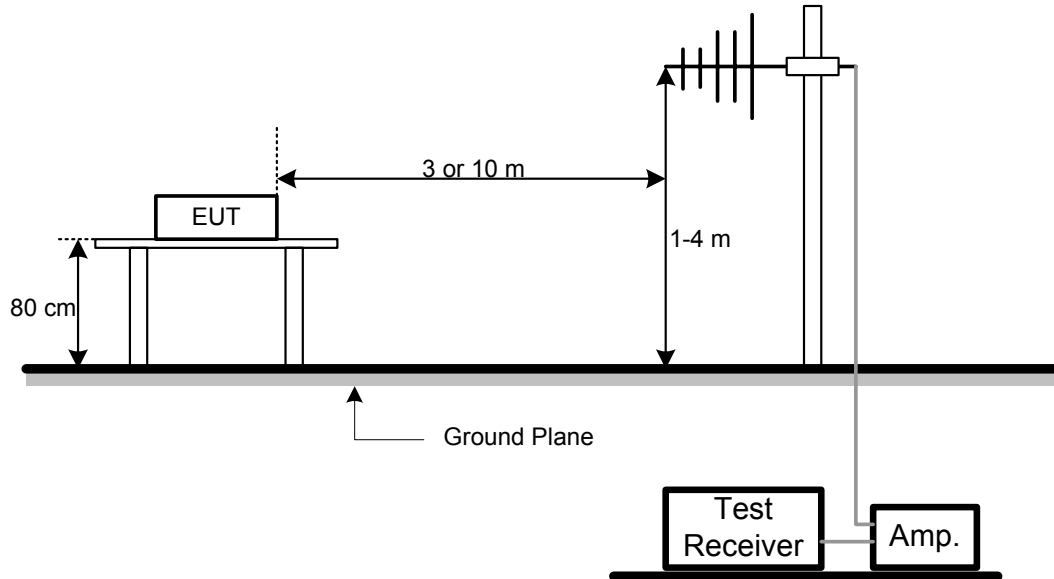

4.3.6 EUT OPERATING CONDITIONS

The EUT tested system was configured as the statements of 4.1.6 Unless otherwise a special operating condition is specified in the follows during the testing.



4.3.7 TEST RESULTS-BETWEEN 30MHZ AND 1000MHZ

E.U.T :	Flexible Embedded System	Model Name :	FES-6110
Temperature :	32 °C	Relative Humidity :	58%
Test Voltage :	AC 230V/50Hz		
Test Mode :	FULL SYSTEM D-SUB+DVI 1600*1200/60Hz (FES-6110)		

Freq. (MHz)	Ant. H/V	Reading(RA) (dBuV)	Corr.Factor(CF) (dB)	Measured(FS) (dBuV/m)	Limits(QP) (dBuV/m)	Margin (dB)	Note
82.33	V	40.56	-9.92	30.64	40.00	- 9.36	
180.87	V	40.37	-5.88	34.49	40.00	- 5.51	
240.03	V	48.60	-5.75	42.85	47.00	- 4.15	(QP)
647.32	V	31.51	4.17	35.68	47.00	- 11.32	
720.00	V	39.32	5.18	44.50	47.00	- 2.50	
808.57	V	31.00	6.64	37.64	47.00	- 9.36	

Remark :

- (1) Reading in which marked as QP or Peak means measurements by using are Quasi-Peak Mode or Peak Mode with Detector BW=120KHz ; SPA setting in RBW=120KHz, VBW =120KHz, Swp. Time = 0.3 sec./MHz ◦
- (2) All readings are Peak unless otherwise stated QP in column of 『 Note 』 . Peak denotes that the Peak reading compliance with the QP Limits and then QP Mode measurement didn't perform ◦
- (3) Measuring frequency range from 30MHz to 1000MHz ◦
- (4) If the peak scan value lower limit more than 20dB, then this signal data does not how in table ◦

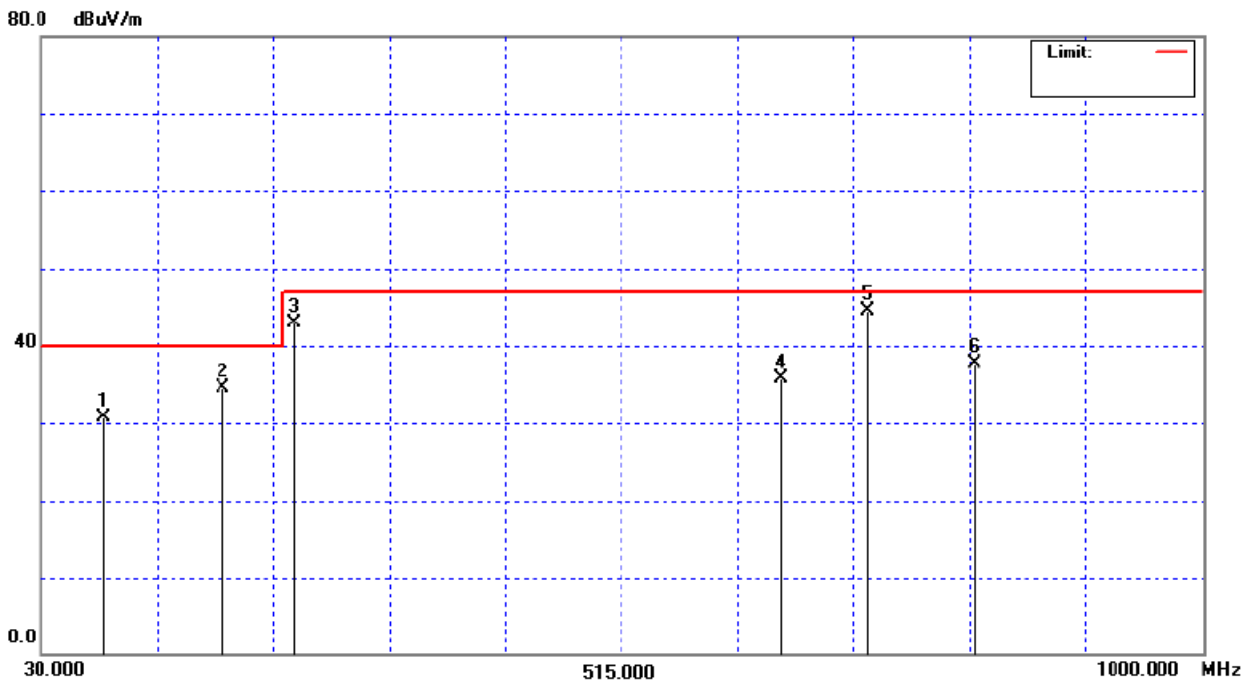



E.U.T :	Flexible Embedded System	Model Name :	FES-6110
Temperature :	32 °C	Relative Humidity :	58%
Test Voltage :	AC 230V/50Hz		
Test Mode :	FULL SYSTEM D-SUB+DVI 1600*1200/60Hz (FES-6110)		

Freq. (MHz)	Ant. H/V	Reading(RA) (dBuV)	Corr.Factor(CF) (dB)	Measured(FS) (dBuV/m)	Limits(QP) (dBuV/m)	Margin (dB)	Note
144.04	H	33.13	-4.83	28.30	40.00	- 11.70	
180.91	H	37.27	-5.89	31.38	40.00	- 8.62	
240.01	H	49.90	-5.75	44.15	47.00	- 2.85	(QP)
365.13	H	36.52	-2.32	34.20	47.00	- 12.80	
432.97	H	37.72	-0.16	37.56	47.00	- 9.44	
720.00	H	38.19	5.18	43.37	47.00	- 3.63	

Remark :

- (1) Reading in which marked as QP or Peak means measurements by using are Quasi-Peak Mode or Peak Mode with Detector BW=120KHz ; SPA setting in RBW=120KHz, VBW =120KHz, Swp. Time = 0.3 sec./MHz ◦
- (2) All readings are Peak unless otherwise stated QP in column of 『 Note 』 . Peak denotes that the Peak reading compliance with the QP Limits and then QP Mode measurement didn't perform ◦
- (3) Measuring frequency range from 30MHz to 1000MHz ◦
- (4) If the peak scan value lower limit more than 20dB, then this signal data does not show in table ◦

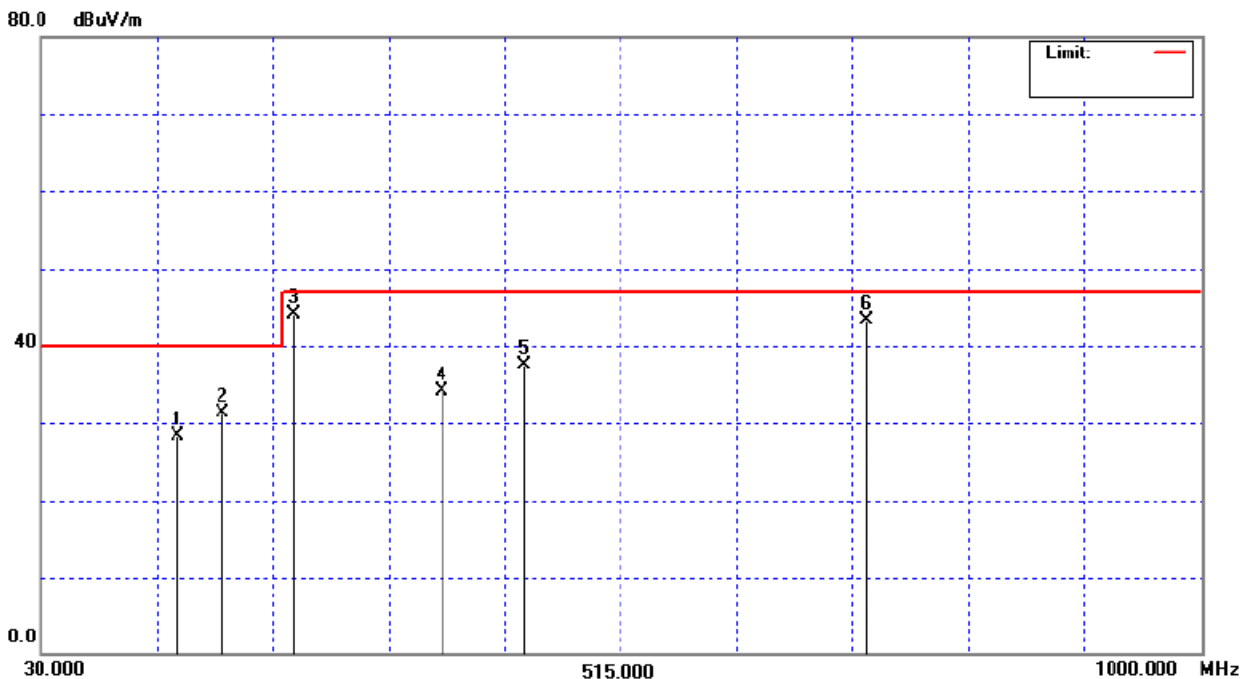



4.3.8 TEST RESULTS-ABOVE 1000MHZ

E.U.T :	Flexible Embedded System	Model Name :	FES-6110
Temperature :	23 °C	Relative Humidity :	54%
Test Voltage :	AC 230V/50Hz		
Test Mode :	FULL SYSTEM D-SUB+DVI 1600*1200/60Hz (FES-6110)		

Freq. (MHz)	Ant.Pol. (H/V)	Reading(dBuV)		Ant./CF CF(dB)	Act.(dBuV/m)		Limit(dBuV/m)		Note
		Peak	AV		Peak	AV	Peak	AV	
1320.00	V	52.92	*	-6.15	46.77	*	76.00	56.00	
1600.00	V	53.83	*	-4.95	48.88	*	76.00	56.00	
1780.00	V	52.70	*	-4.60	48.10	*	76.00	56.00	
2100.00	V	56.13	*	-3.79	52.34	*	76.00	56.00	
2260.00	V	56.94	*	-3.17	53.77	*	76.00	56.00	
2420.00	V	51.97	*	-2.56	49.41	*	76.00	56.00	

Remark :

- (1) Reading in which marked as PK means measurements by using are Peak Mode with instrument setting in RBW= 1 MHz, VBW= 1 MHz, Swp. Time = Auto.
Reading in which marked as AV means measurements by using are Average Mode with instrument setting in RBW= 1 MHz, VBW= 10 Hz, Swp. Time = Auto.
- (2) All readings are PK Mode value unless otherwise stated AVG in column of 『Note』 . If the PK Mode Measured value compliance with the PK Limits and lower than AVG Limits, the EUT shall be deemed to meet both PK & AVG Limits and then only PK Mode was measured, but AVG Mode didn't perform. In this case, a " * " marked in AVG Mode column of Interference Voltage Measured.
- (3) Measuring frequency range above 1000MHz.

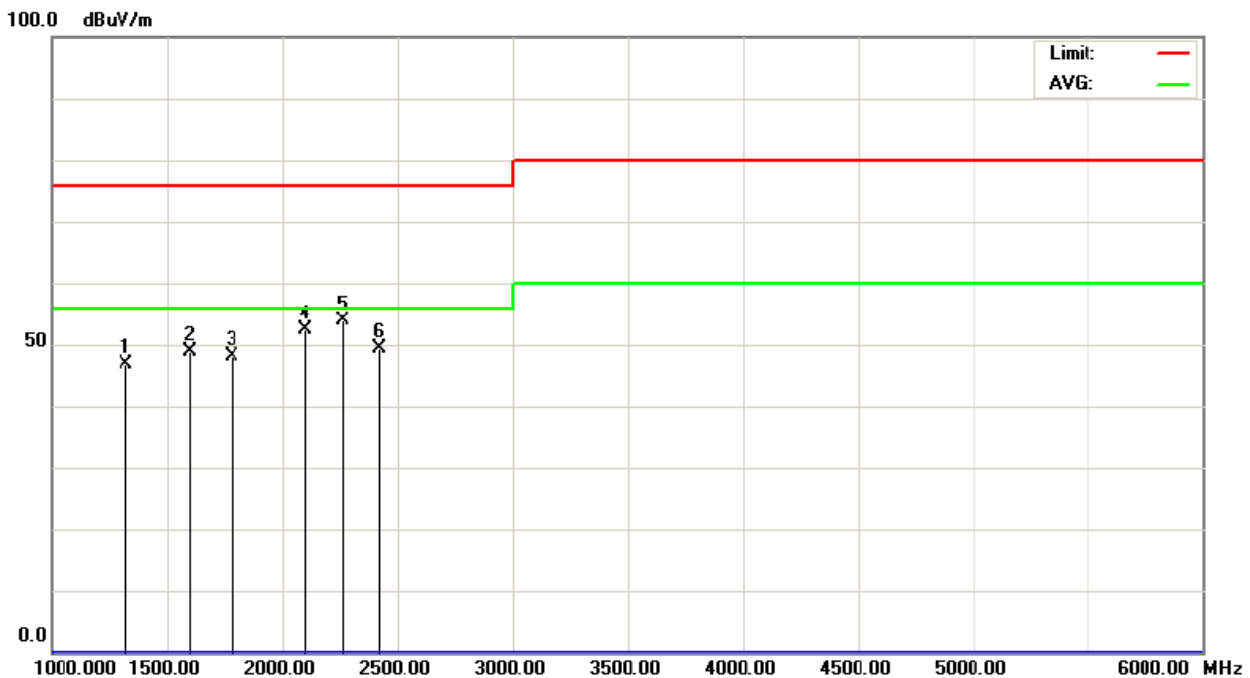



E.U.T :	Flexible Embedded System	Model Name :	FES-6110
Temperature :	23 °C	Relative Humidity :	54%
Test Voltage :	AC 230V/50Hz		
Test Mode :	FULL SYSTEM D-SUB+DVI 1600*1200/60Hz (FES-6110)		

Freq. (MHz)	Ant.Pol. (H/V)	Reading(dBuV)		Ant./CF CF(dB)	Act.(dBuV/m)		Limit(dBuV/m)		Note
		Peak	AV		Peak	AV	Peak	AV	
1330.00	H	56.54	*	-6.10	50.44	*	76.00	56.00	
1610.00	H	50.33	*	-4.93	45.40	*	76.00	56.00	
1830.00	H	50.12	*	-4.50	45.62	*	76.00	56.00	
1940.00	H	50.48	*	-4.29	46.19	*	76.00	56.00	
2270.00	H	54.16	*	-3.13	51.03	*	76.00	56.00	
2420.00	H	47.37	*	-2.56	44.81	*	76.00	56.00	

Remark :

- (1) Reading in which marked as PK means measurements by using are Peak Mode with instrument setting in RBW= 1 MHz, VBW= 1 MHz, Swp. Time = Auto.
Reading in which marked as AV means measurements by using are Average Mode with instrument setting in RBW= 1 MHz, VBW= 10 Hz, Swp. Time = Auto.
- (2) All readings are PK Mode value unless otherwise stated AVG in column of 『Note』 . If the PK Mode Measured value compliance with the PK Limits and lower than AVG Limits, the EUT shall be deemed to meet both PK & AVG Limits and then only PK Mode was measured, but AVG Mode didn't perform. In this case, a " * " marked in AVG Mode column of Interference Voltage Measured.
- (3) Measuring frequency range above 1000MHz.

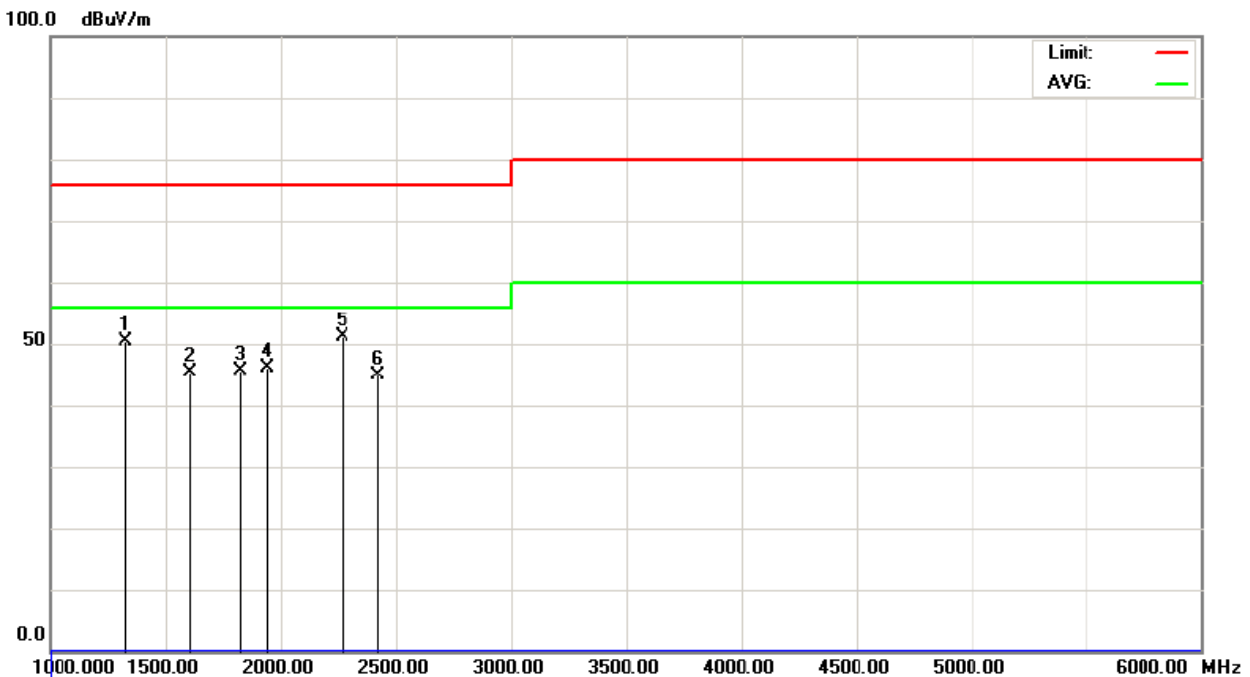



4.4 HARMONICS CURRENT MEASUREMENT

4.4.1 LIMITS OF HARMONICS CURRENT MEASUREMENT

IEC 555-2					
Table - I			Table - II		
Equipment Category	Harmonic Order n	Max. Permissible Harmonic Current (in Amperes)	Equipment Category	Harmonic Order n	Max. Permissible Harmonic Current (in Amperes)
Non Portable Tools or TV Receivers	Odd Harmonics		TV Receivers	Odd Harmonics	
	3	2.30		3	0.80
	5	1.14		5	0.60
	7	0.77		7	0.45
	9	0.40		9	0.30
	11	0.33		11	0.17
	13	0.21		13	0.12
	15 ≤ n ≤ 39	0.15 · 15/n		15 ≤ n ≤ 39	0.10 · 15/n
	Even Harmonics			Even Harmonics	
	2	1.08		2	0.30
4	0.43	4	0.15		
8	0.30				
8 ≤ n ≤ 40	0.23 · 8/n	DC	0.05		

EN 61000-3-2/IEC 61000-3-2					
Equipment Category	Max. Permissible Harmonic Current (in Amperes)	Equipment Category	Harmonic Order n	Max. Permissible Harmonic Current (in A) (mA/w)	
Class A	Same as Limits Specified in 4-2.1, Table - I, but only odd harmonics required	Class D	3	2.30	3.4
			5	1.14	1.9
			7	0.77	1.0
			9	0.40	0.5
			11	0.33	0.35
			13 ≤ n ≤ 39	see Table I	3.85/n
only odd harmonics required					

4.4.2 MEASUREMENT INSTRUMENTS LIST

Item	Kind of Equipment	Manufacturer	Type No.	Serial No.	Calibrated until
1	Harmonic & Flicker	California	PACS-1	72345	Mar. 17, 2011
2	Power Source	California	3001iX	56310	Mar. 17, 2011
3	Measurement Software	California	CTS 3.0 (Version 3.2.0.26)	CIC632	N/A

Remark: " N/A" denotes No Model Name / Serial No. and No Calibration specified.

4.4.3 TEST PROCEDURE

- a. The EUT was placed on the top of a wooden table 0.8 meters above the ground and operated to produce the maximum harmonic components under normal operating conditions.
- b. The classification of EUT is according to section 5 of EN 61000-3-2: 2006. The EUT is classified as follows:
 - Class A: Balanced three-phase equipment, Household appliances excluding equipment as Class D, Tools excluding portable tools, Dimmers for incandescent lamps, audio equipment, equipment not specified in one of the three other classes.
 - Class B: Portable tools. Portable tools.; Arc welding equipment which is not professional equipment.
 - Class C: Lighting equipment.
 - Class D: Equipment having a specified power less than or equal to 600 W of the following types: Personal computers and personal computer monitors and television receivers.
- c. The correspondent test program of test instrument to measure the current harmonics emanated from EUT is chosen. The measure time shall be not less than the time necessary for the EUT to be exercised.
- d. For the actual test configuration, please refer to the related item –EUT Test Photos.

4.4.4 DEVIATION FROM TEST STANDARD

No deviation

4.4.5 TEST SETUP

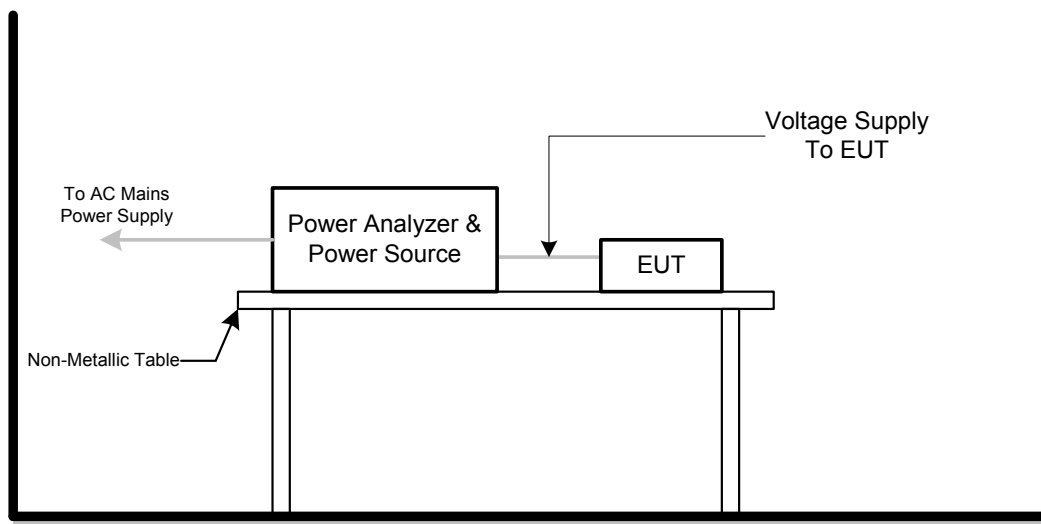

4.4.6 EUT OPERATING CONDITIONS

The EUT tested system was configured as the statements of 4.1.6 Unless otherwise a special operating condition is specified in the follows during the testing.



4.4.7 TEST RESULTS

Harmonics – Class-D per Ed. 3.0 (2005-11) (Run time) incl. inter-harmonics			
E.U.T :	Flexible Embedded System	Model Name :	FES-6110
Temperature :	22 °C	Relative Humidity :	48%
Test Voltage :	AC 230V/50Hz		
Test Mode :	FULL SYSTEM D-SUB+DVI 1600*1200/60Hz (FES-6110)		

Current & voltage waveforms

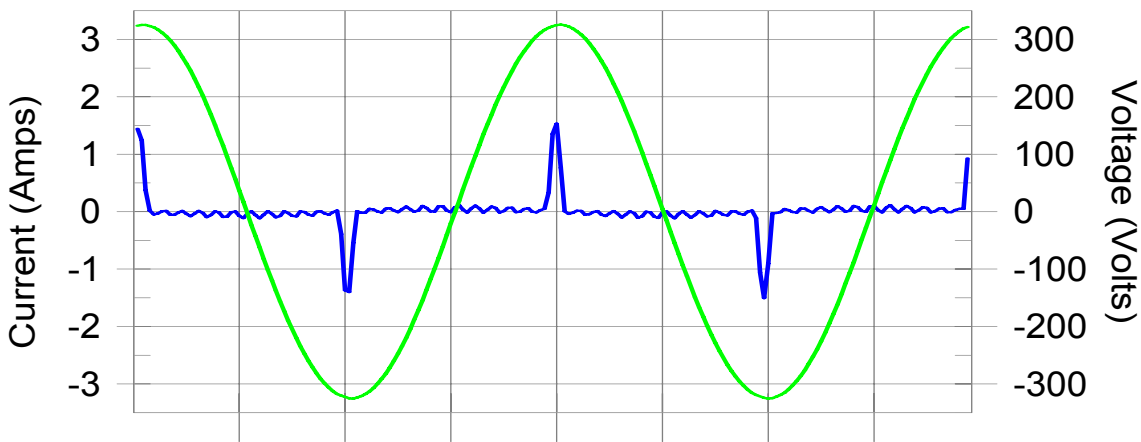

Harmonics and Class D limit line

European Limits

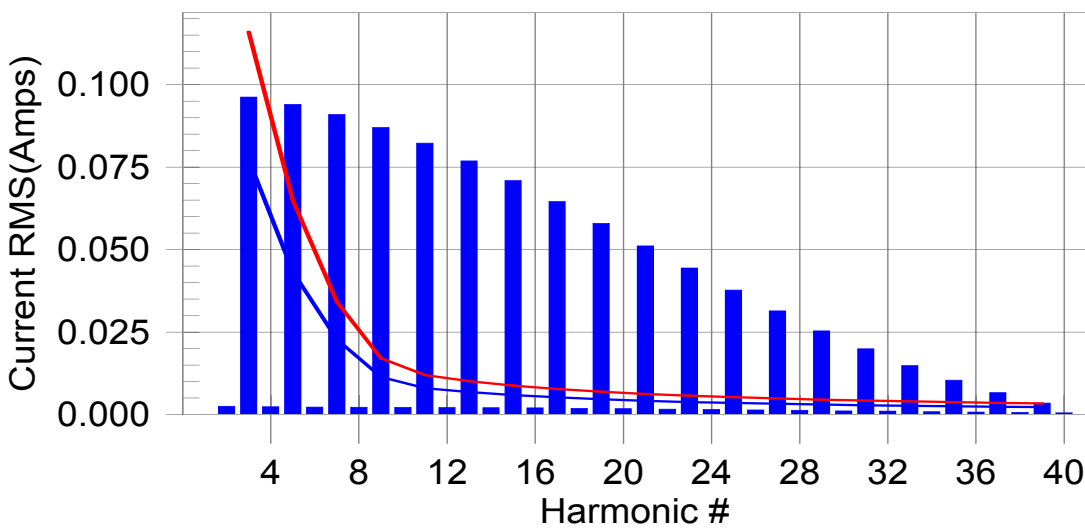

Test result: N/L Worst harmonic was #0 with 0.00% of the limit.



Current Test Result Summary (Run time)			
E.U.T :	Flexible Embedded System	Model Name :	FES-6110
Temperature :	22 °C	Relative Humidity :	48%
Test Voltage :	AC 230V/50Hz		
Highest parameter values during test:			
V_RMS (Volts):	229.91	Frequency(Hz):	50.00
I_Peak (Amps):	1.621	I_RMS (Amps):	0.292
I_Fund (Amps):	0.107	Crest Factor:	5.658
Power (Watts):	22.8	Power Factor:	0.348
Test Mode:	FULL SYSTEM D-SUB+DVI 1600*1200/60Hz (FES-6110)		

Harm# Harms(avg) 100% Limit % of Limit Harms(max) 150% Limit % of Limit Status

2	0.003						
3	0.096	0.077	0.0	0.096	0.116	0.00	N/L
4	0.002						
5	0.094	0.043	0.0	0.094	0.065	0.00	N/L
6	0.002						
7	0.091	0.023	0.0	0.091	0.034	0.00	N/L
8	0.002						
9	0.087	0.011	0.0	0.087	0.017	0.00	N/L
10	0.002						
11	0.082	0.008	0.0	0.082	0.012	0.00	N/L
12	0.002						
13	0.077	0.007	0.0	0.077	0.010	0.00	N/L
14	0.002						
15	0.071	0.006	0.0	0.071	0.009	0.00	N/L
16	0.002						
17	0.064	0.005	0.0	0.065	0.008	0.00	N/L
18	0.002						
19	0.058	0.005	0.0	0.058	0.007	0.00	N/L
20	0.002						
21	0.051	0.004	0.0	0.051	0.006	0.00	N/L
22	0.002						
23	0.044	0.004	0.0	0.044	0.006	0.00	N/L
24	0.002						
25	0.038	0.004	0.0	0.038	0.005	0.00	N/L
26	0.001						
27	0.031	0.003	0.0	0.031	0.005	0.00	N/L
28	0.001						
29	0.025	0.003	0.0	0.025	0.005	0.00	N/L
30	0.001						
31	0.020	0.003	0.0	0.020	0.004	0.00	N/L
32	0.001						
33	0.015	0.003	0.0	0.015	0.004	0.00	N/L
34	0.001						
35	0.010	0.003	0.0	0.010	0.004	0.00	N/L
36	0.001						
37	0.007	0.002	0.0	0.007	0.004	0.00	N/L
38	0.001						
39	0.003	0.002	0.0	0.003	0.003	0.00	N/L
40	0.001						

Note: The EUT power level is below 75.0 Watts and therefore has no defined limits



Voltage Source Verification Data (Run time)			
E.U.T :	Flexible Embedded System	Model Name :	FES-6110
Temperature :	22 °C	Relative Humidity :	48%
Test Voltage :	AC 230V/50Hz		
Highest parameter values during test:			
V_RMS (Volts):	229.91	Frequency(Hz):	50.00
I_Peak (Amps):	1.621	I_RMS (Amps):	0.292
I_Fund (Amps):	0.107	Crest Factor:	5.658
Power (Watts):	22.8	Power Factor:	0.348
Test Mode:	FULL SYSTEM D-SUB+DVI 1600*1200/60Hz (FES-6110)		

Harm#	Harmonics V-rms	Limit V-rms	% of Limit	Status
2	0.076	0.460	16.47	OK
3	0.435	2.069	21.01	OK
4	0.019	0.460	4.20	OK
5	0.011	0.920	1.19	OK
6	0.018	0.460	4.00	OK
7	0.037	0.690	5.44	OK
8	0.014	0.460	2.97	OK
9	0.042	0.460	9.13	OK
10	0.013	0.460	2.73	OK
11	0.045	0.230	19.70	OK
12	0.015	0.230	6.54	OK
13	0.050	0.230	21.58	OK
14	0.009	0.230	3.99	OK
15	0.050	0.230	21.86	OK
16	0.016	0.230	6.86	OK
17	0.046	0.230	20.17	OK
18	0.019	0.230	8.32	OK
19	0.055	0.230	23.84	OK
20	0.015	0.230	6.73	OK
21	0.045	0.230	19.67	OK
22	0.007	0.230	3.23	OK
23	0.049	0.230	21.12	OK
24	0.006	0.230	2.42	OK
25	0.041	0.230	18.04	OK
26	0.007	0.230	3.13	OK
27	0.039	0.230	17.04	OK
28	0.006	0.230	2.70	OK
29	0.026	0.230	11.40	OK
30	0.006	0.230	2.57	OK
31	0.030	0.230	12.93	OK
32	0.005	0.230	2.24	OK
33	0.021	0.230	8.98	OK
34	0.002	0.230	0.66	OK
35	0.017	0.230	7.44	OK
36	0.003	0.230	1.50	OK
37	0.008	0.230	3.64	OK
38	0.003	0.230	1.14	OK
39	0.008	0.230	3.63	OK
40	0.006	0.230	2.64	OK



4.5 VOLTAGE FLUCTUATION AND FLICKERS MEASUREMENT

4.5.1 LIMITS OF VOLTAGE FLUCTUATION AND FLICKERS MEASUREMENT

Tests	Limits		Descriptions
	IEC555-3	IEC/EN 61000-3-3	
Pst	≤ 1.0, Tp= 10 min.	≤ 1.0, Tp= 10 min.	Short Term Flicker Indicator
Plt	N/A	≤ 0.65, Tp=2 hr.	Long Term Flicker Indicator
dc	≤ 3%	≤ 3.3%	Relative Steady-State V-Chang
dmax	≤ 4%	≤ 4%	Maximum Relative V-change
d (t)	N/A	≤ 3.3% for > 500 ms	Relative V-change characteristic

4.5.2 MEASUREMENT INSTRUMENTS LIST

Item	Kind of Equipment	Manufacturer	Type No.	Serial No.	Calibrated until
1	Harmonic & Flicker	California	PACS-1	72345	Mar. 17, 2011
2	Power Source	California	3001iX	56310	Mar. 17, 2011
3	Measurement Software	California	CTS 3.0 (Version 3.2.0.26)	CIC632	N/A

Remark: " N/A" denotes No Model Name / Serial No. and No Calibration specified.

4.5.3 TEST PROCEDURE

a. Harmonic Current Test:

Test was performed according to the procedures specified in Clause 5.0 of IEC555-2 and/or Sub-clause 6.2 of IEC/EN 61000-3-2 depend on which standard adopted for compliance measurement.

b. Fluctuation and Flickers Test:

Tests was performed according to the Test Conditions/Assessment of Voltage Fluctuations specified in Clause 5.0/6.0 of IEC555-3 and/or Clause 6.0/4.0 of IEC/EN 61000-3-3 depend on which standard adopted for compliance measurement.

c. All types of harmonic current and/or voltage fluctuation in this report are assessed by direct measurement using flicker-meter.

d. For the actual test configuration, please refer to the related Item –EUT Test Photos.

4.5.4 DEVIATION FROM TEST STANDARD

No deviation

4.5.5 TESTSETUP

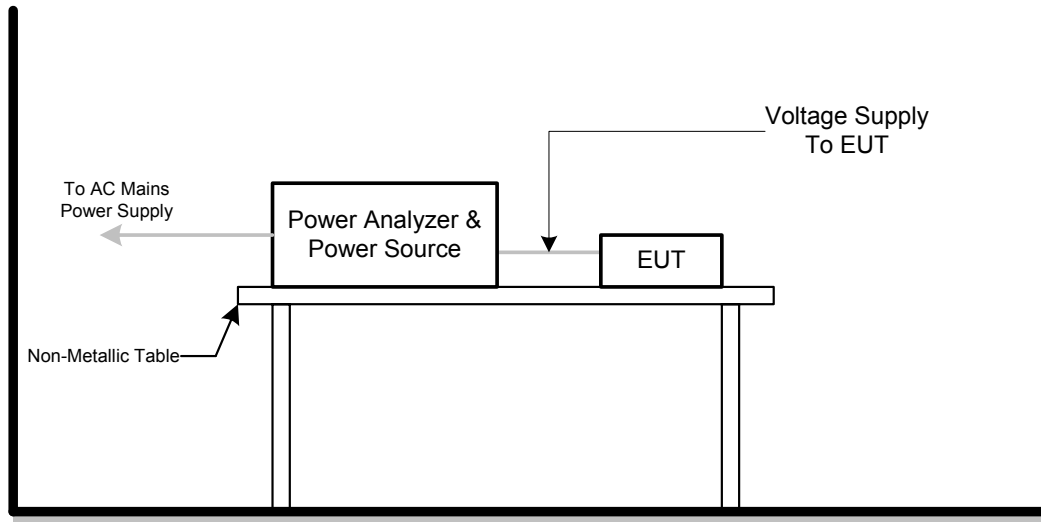

4.5.6 EUT OPERATING CONDITIONS

The EUT tested system was configured as the statements of **4.1.6** Unless otherwise a special operating condition is specified in the follows during the testing.



4.5.7 TEST RESULTS

E.U.T :	Flexible Embedded System	Model Name :	FES-6110
Temperature :	22 °C	Relative Humidity :	48%
Test Voltage :	AC 230V/50Hz		
Test Mode :	FULL SYSTEM D-SUB+DVI 1600*1200/60Hz (FES-6110)		

Pst_i and limit line

European Limits

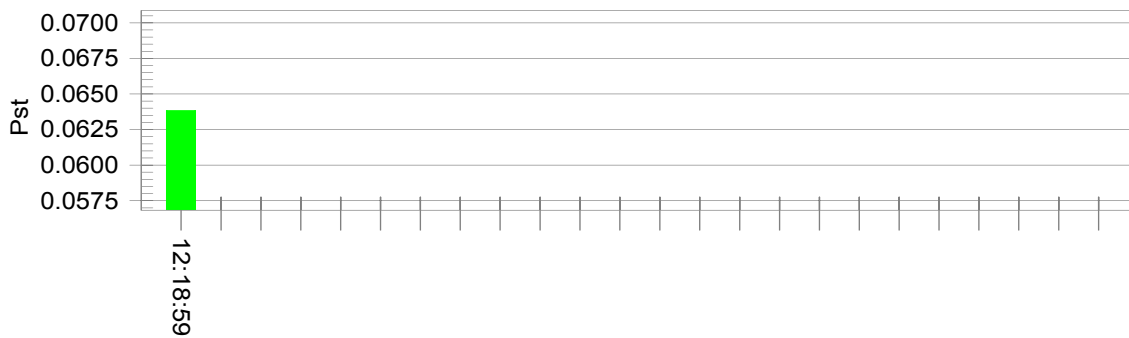

Plt and limit line



Parameter values recorded during the test:

Vrms at the end of test (Volt):229.83

Highest dt (%):	0.00	Test limit (%):	3.30	Pass
Time(mS) > dt:	0.0	Test limit (mS):	500.0	Pass
Highest dc (%):	0.00	Test limit (%):	3.30	Pass
Highest dmax (%):	0.00	Test limit (%):	4.00	Pass



5. EMC IMMUNITY TEST

5.1 STANDARD COMPLIANCE/SERVIRTY LEVEL/CRITERIA

Tests Standard No.	TEST SPECIFICATION Level	Test Mode Test Ports	Perform. Criteria	Remark
1. ESD IEC/EN 61000-4-2	8kV air discharge 4kV contact discharge	Direct Mode	B	
	4kV HCP discharge 4kV VCP discharge	Indirect Mode	B	
2. RS IEC/EN 61000-4-3	80 MHz to 1000 MHz 3V/m(rms), 1 KHz, 80%, AM modulated	Enclosure	A	
3. EFT/Burst IEC/EN 61000-4-4	1.0kV(peak) 5/50ns Tr/Th 5KHz Repetition Freq.	Power Supply Port	B	
	0.5 kV(peak) 5/50ns Tr/Th 5KHz Repetition Freq.	CTL/Signal Data Line Port	B	
4. Surges IEC/EN 61000-4-5	1 kV(5P/5N) 1.2/50(8/20) Tr/Th us	L-N	B	
	2 kV(5P/5N) 1.2/50(8/20) Tr/Th us	L-PE N-PE	B	
5 Injected Current IEC/EN 61000-4-6	0.15 MHz to 80 MHz 3V(rms), 1KHz 80%, AM Modulated 150Ω source impedance	CTL/Signal Port	A	
	0.15 MHz to 80 MHz 3V(rms), 1KHz 80%, AM Modulated 150Ω source impedance	AC Power Port	A	
	0.15 MHz to 80 MHz 3V(rms), 1KHz 80%, AM Modulated 150Ω source impedance	DC Power Port	A	N/A
6. Power Frequency Magnetic Field IEC/EN 61000-4-8	50 Hz, 1A/m	Enclosure	A	
7. Volt. Interruptions Volt. Dips IEC/EN 61000-4-11	Voltage dip >95%		B	
	Voltage dip 30%	AC Power Port	C	
	Interruption >95%		C	

* Remark:

N/A : denotes test is not applicable in this Test Report

(1) : The EUT is a battery operating device and no any other cable connection to PC device.

(2) : Applicable only to cables which according to the manufacturer's specification supports communication on cables lengths greater than 3 m.

(3) : Applicable only to equipment containing devices susceptible to magnetic fields



5.2 GENERAL PERFORMANCE CRITERIA

According to **EN55024** standard, the general performance criteria as following:

Criterion A	<p>The equipment shall continue to operate as intended without operator intervention. No degradation of performance or loss of function is allowed below a performance level specified by the manufacturer when the equipment is used as intended. The performance level may be replaced by a permissible loss of performance.</p> <p>If the minimum performance level or the permissible performance loss is not specified by the manufacturer, then either of these may be derived from the product description and documentation, and by what the user product description and documentation, and by what the user may reasonably expect from the equipment if used as intended.</p>
Criterion B	<p>After the test, the equipment shall continue to operate as intended without operator Intervention. No degradation of performance or loss of function is allowed, after the application of the phenomenon below a performance level specified by the manufacturer, when the equipment is used as intended. The performance level may be replaced by a permissible loss of performance.</p> <p>During the test, degradation of performance is allowed. However, no change of operating state if stored data allowed to persist after the test. If the minimum performance level (or the permissible performance loss) is not specified by the manufacturer, then either of these may be derived from the product description and documentation, and by what the user may reasonably expect from the equipment if used as intended.</p>
Criterion C	<p>Loss of function is allowed, provided the function is self-recoverable, or can be restored by the operation of the controls by the user in accordance with the manufacturer’s instructions.</p> <p>Functions, and/or information stored in non-volatile memory, or protected by a battery backup, shall not be lost.</p>

5.3 GENERAL PERFORMANCE CRITERIA TEST SETUP

The EUT tested system was configured as the statements of **4.1.6** Unless otherwise a special operating condition is specified in the follows during the testing.



5.4 ESD TESTING

5.4.1 TEST SPECIFICATION

Basic Standard:	IEC/EN 61000-4-2
Discharge Impedance:	330 ohm / 150 pF
Required Performance	B
Discharge Voltage:	Air Discharge : 2kV/4kV/8kV (Direct) Contact Discharge : 2kV/4kV (Direct/Indirect)
Polarity:	Positive & Negative
Number of Discharge:	Air Discharge: min. 20 times at each test point Contact Discharge: min. 200 times in total
Discharge Mode:	Single Discharge
Discharge Period:	1 second minimum

5.4.2 MEASUREMENT INSTRUMENTS

Item	Kind of Equipment	Manufacturer	Type No.	Serial No.	Calibrated until
1	ESD Simulator	Schaffner	NSG435	1224	Jul. 21, 2010

Remark: " N/A" denotes No Model Name / Serial No. and No Calibration specified.

5.4.3 TEST PROCEDURE

The test generator necessary to perform direct and indirect application of discharges to the EUT in the following manner:

- a. Contact discharge was applied to conductive surfaces (Direct) and coupling planes (Indirect) of the EUT.

During the test, it was performed with single discharges. For the single discharge time between successive single discharges was at least 1 second. The EUT shall be exposed to at least 200 discharges, 100 each at negative and positive polarity, at a minimum of four test points. One of the test points shall be subjected to at least 50 indirect discharges to the center of the front edge of the horizontal coupling plane. The remaining three test points shall each receive at least 50 direct contact discharges.

If no direct contact test points are available, then at least 200 indirect discharges shall be applied in the indirect mode. Test shall be performed at a maximum repetition rate of one discharge per second.

Vertical Coupling Plane (VCP):

The coupling plane, of dimensions 0.5m x 0.5m, is placed parallel to, and positioned at a distance 0.1m from, the EUT, with the Discharge Electrode touching the coupling plane.

The four faces of the EUT will be performed with electrostatic discharge.

Horizontal Coupling Plane (HCP):

The coupling plane is placed under to the EUT. The generator shall be positioned vertically at a distance of 0.1m from the EUT, with the Discharge Electrode touching the coupling plane.

The four faces of the EUT will be performed with electrostatic discharge.

- b. Air discharges at insulation surfaces of the EUT.

It was at least ten single discharges with positive and negative at the same selected point.

- c. For the actual test configuration, please refer to the related Item –EUT Test Photos.

5.4.4 DEVIATION FROM TEST STANDARD

No deviation

5.4.5 TEST SETUP

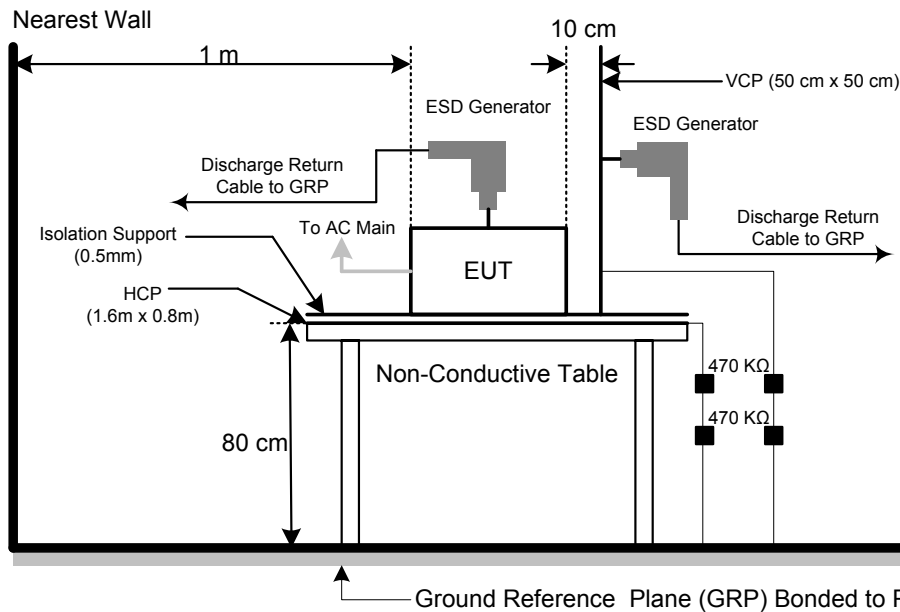

Note:

TABLE-TOP EQUIPMENT

The configuration consisted of a wooden table 0.8 meters high standing on the Ground Reference Plane. The GRP consisted of a sheet of aluminum at least 0.25mm thick, and 2.5 meters square connected to the protective grounding system. A Horizontal Coupling Plane (1.6m x 0.8m) was placed on the table and attached to the GRP by means of a cable with 940k total impedance. The equipment under test, was installed in a representative system as described in section 7 of IEC /EN 61000-4-2, and its cables were placed on the HCP and isolated by an insulating support of 0.5mm thickness. A distance of 1-meter minimum was provided between the EUT and the walls of the laboratory and any other metallic structure.

FLOOR-STANDING EQUIPMENT

The equipment under test was installed in a representative system as described in section 7 of IEC/EN 61000-4-2, and its cables were isolated from the Ground Reference Plane by an insulating support of 0.1-meter thickness. The GRP consisted of a sheet of aluminum that is at least 0.25mm thick, and 2.5 meters square connected to the protective grounding system and extended at least 0.5 meters from the EUT on all sides.



5.4.6 TEST RESULTS

E.U.T :	Flexible Embedded System	Model Name :	FES-6110
Temperature :	22 °C	Relative Humidity :	47%
Pressure :	1016 hPa	Test Voltage :	AC 230V/50Hz
Test Mode :	FULL SYSTEM D-SUB+DVI 1600*1200/60Hz (FES-6110)		

Mode	Air Discharge								Contact Discharge							
	2kV		4kV		8kV		15kV		2kV		4kV		6kV		8kV	
Location	P	N	P	N	P	N	P	N	P	N	P	N	P	N	P	N
1	A	A	A	A	A	A			A	A	A	A				
2	A	A	A	A	A	A			A	A	A	A				
3	A	A	A	A	A	A			A	A	A	A				
4	A	A	A	A	A	A			A	A	A	A				
5	A	A	A	A	A	A			A	A	A	A				
6	A	A	A	A	A	A			A	A	A	A				
7									A	A	A	A				
8									A	A	A	A				
9									A	A	A	A				
10									A	A	A	A				
11									A	A	A	A				
12									A	A	A	A				
13									A	A	A	A				
14									A	A	A	A				
15									A	A	A	A				
Criteria	B								B							
Result	A								A							
Judgment	PASS								PASS							

Mode	HCP Discharge								VCP Discharge							
	2kV		4kV		6kV		8kV		2kV		4kV		6kV		8kV	
Location	P	N	P	N	P	N	P	N	P	N	P	N	P	N	P	N
1	A	A	A	A					A	A	A	A				
2	A	A	A	A					A	A	A	A				
3	A	A	A	A					A	A	A	A				
4	A	A	A	A					A	A	A	A				
Criteria	B								B							
Result	A								A							
Judgment	PASS								PASS							

Note:

- 1) P/N denotes the Positive/Negative polarity of the output voltage.
- 2) Test condition:
Direct / Indirect (HCP/VCP) discharges: Minimum 25 times (Positive/Negative) at each point. Air discharges: Minimum 10 times (Positive/Negative) at each point.
- 3) Test location(s) in which discharge (Air and contact discharge) to be applied illustrated by photos shown in next page(s)
- 4) The Indirect (HCP/VCP) discharges description of test point as following:
1.left side 2.right side 3.front side 4.rear side
- 5) N/A - denotes test is not applicable in this test report
- 6) Criteria A: There was no change operated with initial operating during the test.
- 7) Criteria B: The EUT function loss during the test, but self-recoverable after the test.
- 8) Criteria C: The system shut down during the test.

5.4.7 PHOTO(S) SHOWN THE LOCATION(S) OF ESD EVALUATED

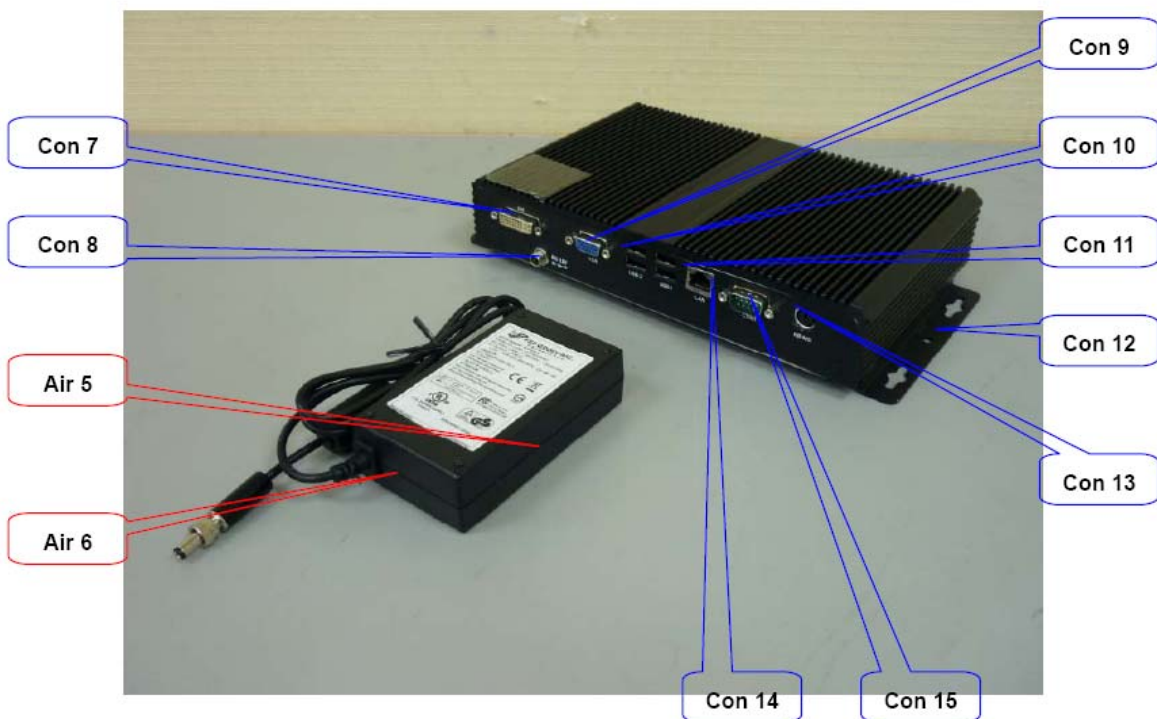
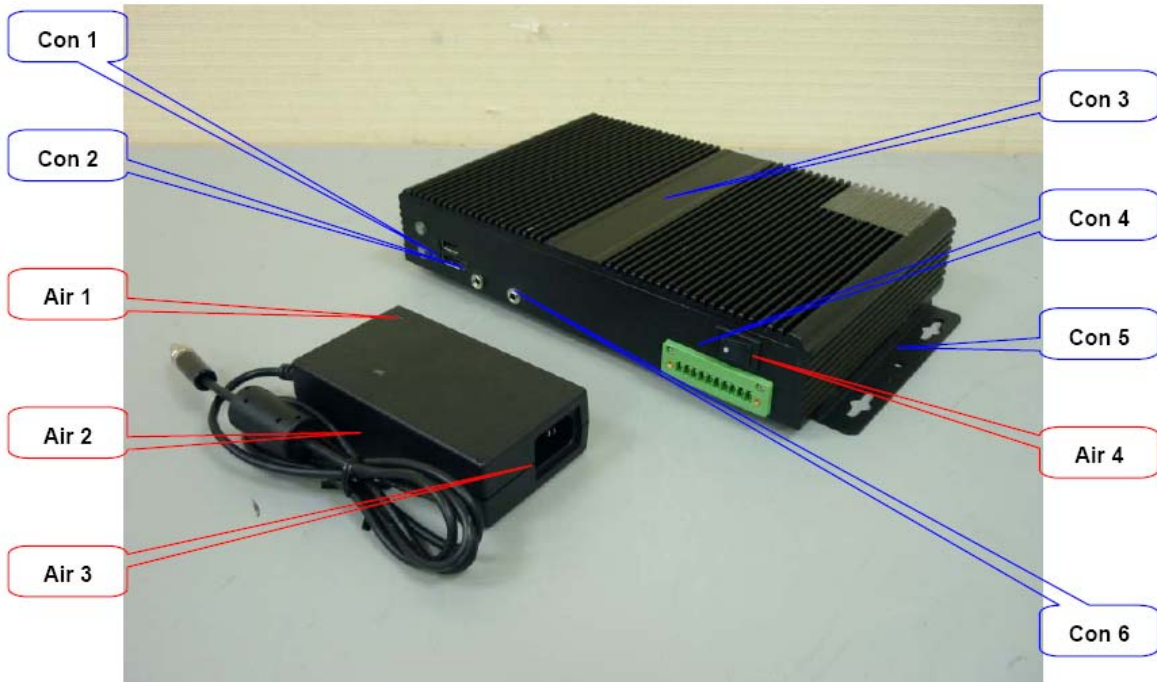



5.5 RS TESTING

5.5.1 TEST SPECIFICATION

Basic Standard:	IEC/EN 61000-4-3
Required Performance	A
Frequency Range:	80 MHz - 1000 MHz
Field Strength:	3 V/m
Modulation:	1kHz Sine Wave, 80%, AM Modulation
Frequency Step:	1% of fundamental
Polarity of Antenna:	Horizontal and Vertical
Test Distance:	3 m
Antenna Height:	1.5 m
Dwell Time:	at least 3 seconds

5.5.2 MEASUREMENT INSTRUMENTS

Item	Kind of Equipment	Manufacturer	Type No.	Serial No.	Calibrated until
1	Signal Generator	R&S	SMT06	832080/007	Jul. 21, 2010
2	Log-Bicon Antenna	Schwarzbeck	VULB 9161	4022	Jun. 04, 2010
3	Power Amplifier	AR	150W1000M1	320946	Jun. 04, 2010
4	Measurement Software	AR	SW1006 (Version 1.22)	321779	N/A

Remark: " N/A" denotes No Model Name / Serial No. and No Calibration specified.

5.5.3 TEST PROCEDURE

The EUT and support equipment, which are placed on a table that is 0.8 meter above ground and the testing was performed in a fully-anechoic chamber.

The testing distance from antenna to the EUT was 3 meters.

The other condition as following manner:

- a. The field strength level was 3V/m.
- b. The frequency range is swept from 80 MHz to 1000 MHz, with the signal 80%amplitude modulated with a 1kHz sine wave. The rate of sweep did not exceed 1.5×10^{-3} decade/s. Where the frequency range is swept incrementally, the step size was 1% of fundamental.
- c. Sweep Frequency 900 MHz, with the Duty Cycle:1/8 and Modulation: Pulse 217 Hz(if applicable)
- d. The dwell time at each frequency shall be not less than the time necessary for the EUT to be able to respond.
- e. The test was performed with the EUT exposed to both vertically and horizontally polarized fields on each of the four sides.
- f. For the actual test configuration, please refer to the related Item –EUT Test Photos.

5.5.4 DEVIATION FROM TEST STANDARD

No deviation

5.5.5 TEST SETUP

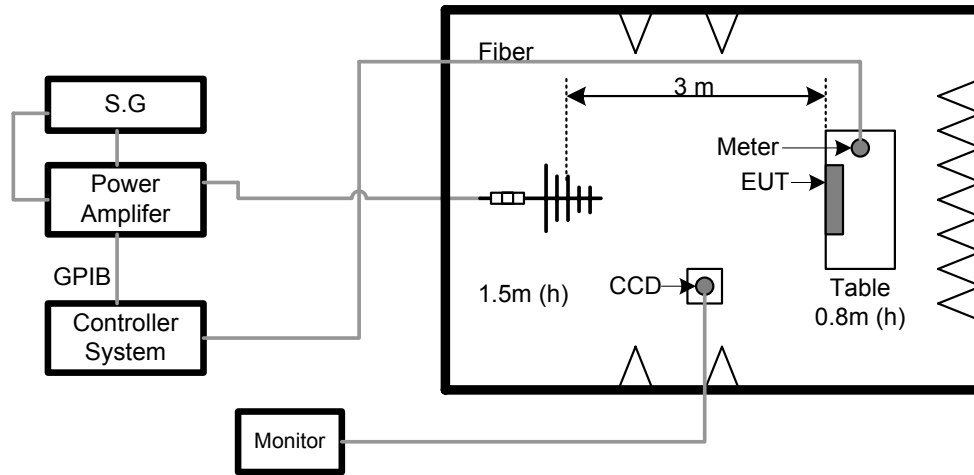

Note:

TABLE-TOP EQUIPMENT

The EUT installed in a representative system as described in section 7 of IEC/EN 61000-4-3 was placed on a non-conductive table 0.8 meters in height. The system under test was connected to the power and signal wire according to relevant installation instructions.

FLOOR-STANDING EQUIPMENT

The EUT installed in a representative system as described in section 7 of IEC/EN 61000-4-3 was placed on a non-conductive wood support 0.1 meters in height. The system under test was connected to the power and signal wire according to relevant installation instructions.



5.5.6 TEST RESULTS

E.U.T :	Flexible Embedded System	Model Name :	FES-6110
Temperature :	25	Relative Humidity :	46
Test Voltage :	AC 230V/50Hz		
Test Mode :	FULL SYSTEM D-SUB+DVI 1600*1200/60Hz (FES-6110)		

Frequency Range (MHz)	RF Field Position	R.F. Field Strength	Azimuth	Perform. Criteria	Results	Judgment
80 - 1000	H / V	3 V/m (rms) AM Modulated 1000Hz, 80%	0	A	A	PASS
			90			
			180			
			270			

Note:

- 1) P/N denotes the Positive/Negative polarity of the output voltage.
- 2) N/A - denotes test is not applicable in this test report.
- 3) Criteria A: There was no change operated with initial operating during the test.
- 4) Criteria B: The EUT function loss during the test, but self-recoverable after the test.
- 5) Criteria C: The system shut down during the test.



5.6 EFT/BURST TESTING

5.6.1 TEST SPECIFICATION

Basic Standard:	IEC/EN 61000-4-4
Required Performance	B
Test Voltage :	Power Line: 1 kV Signal/Control Line: 0.5 kV
Polarity:	Positive & Negative
Impulse Frequency:	5 kHz
Impulse Wave shape :	5/50 ns
Burst Duration:	15 ms
Burst Period:	300 ms
Test Duration:	Not less than 1 min.

5.6.2 MEASUREMENT INSTRUMENTS

Item	Kind of Equipment	Manufacturer	Type No.	Serial No.	Calibrated until
1	EMC Immunity Test System	Thermo	EMCPRO PLUS	0502176	Mar. 04,2011
2	Capacitive Clamp	Thermo	CCL	0502218	N/A
3	Measurement Software	KeyTek	CEWare32 (Version 4.00)	N/A	N/A

Remark: " N/A" denotes No Model Name / Serial No. and No Calibration specified.

5.6.3 TEST PROCEDURE

The EUT and support equipment(s) are placed on a table that is 0.8 meter high above a metal ground plane and should be located 0.1 m+/- 0.01m high above the Ground Reference Plane (1m*1m min. and 0.65mm thick min).

The other condition as following manner:

- a. The length of power cord between the coupling device and the EUT should not exceed 1 meter.
- b. Both positive and negative polarity discharges were applied.
- c. The duration time of each test sequential was 1 minute
- d. For the actual test configuration, please refer to the related Item –EUT Test Photos.

5.6.4 DEVIATION FROM TEST STANDARD

No deviation

5.6.5 TEST SETUP

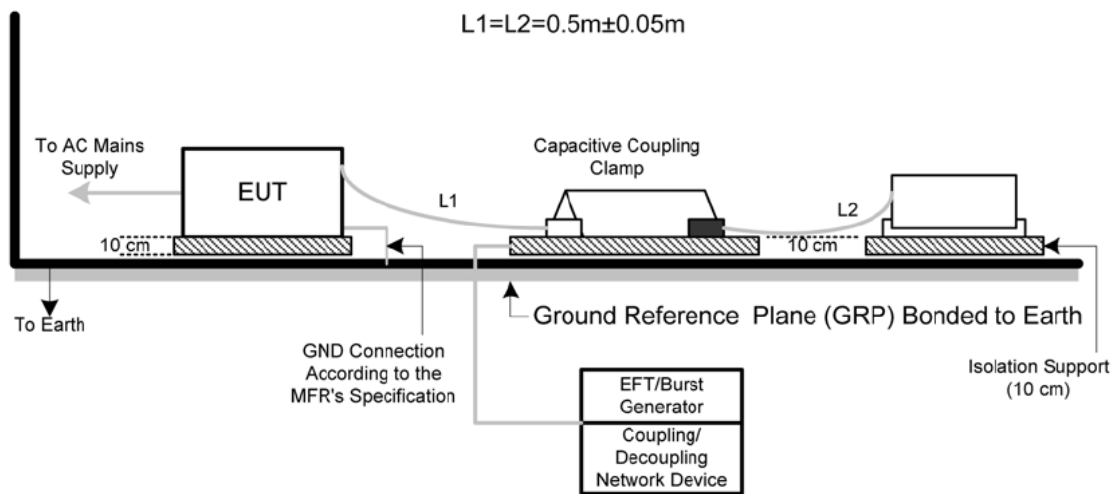
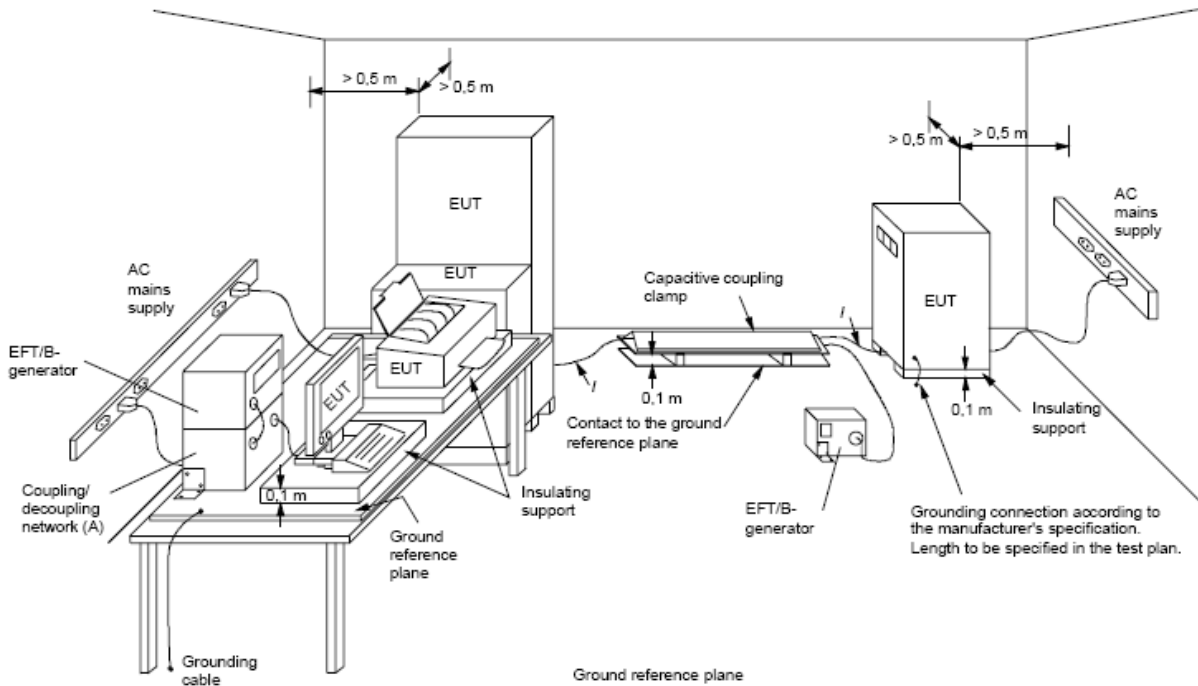

Note:

TABLE-TOP EQUIPMENT

The configuration consisted of a wooden table (0.8m high) standing on the Ground Reference Plane and should be located 0.1 m+/- 0.01m above the Ground Reference Plane. The GRP consisted of a sheet of aluminum (at least 0.25mm thick and 2.5m square) connected to the protective grounding system. A minimum distance of 0.5m was provided between the EUT and the walls of the laboratory or any other metallic structure.

FLOOR-STANDING EQUIPMENT

The EUT installed in a representative system as described in section 7 of IEC/EN 61000-4-4 and its cables, were isolated from the Ground Reference Plane by an insulating support that is 0.1-meter thick. The GRP consisted of a sheet of aluminum (at least 0.25mm thick and 2.5m square) connected to the protective grounding system.



5.6.6 TEST RESULTS

E.U.T :	Flexible Embedded System	Model Name :	FES-6110
Temperature :	22 ° C	Relative Humidity :	47
Test Voltage :	AC 230V/50Hz		
Test Mode :	FULL SYSTEM D-SUB+DVI 1600*1200/60Hz (FES-6110)		

Mode	(X) AC Power Line		() DC Power Line		(X) Signal/Control Line	
Test Level	1kV		0.5kV		0.5kV	
Port(s)	Polarity	Results	Polarity	Results	Polarity	Results
Line (L)	P	A	P		P	
	N	A	N		N	
Neutral (N)	P	A	P		P	
	N	A	N		N	
Ground (PE)	P	A	P		P	
	N	A	N		N	
Signal/Control Line	P		P		P	A
	N		N		N	A
Criteria	B		B		B	
Result	A		N/A		A	
Judgment	PASS		N/A		PASS	

Note:

- 1) P/N denotes the Positive/Negative polarity of the output voltage.
- 2) N/A - denotes test is not applicable in this test report
- 3) Criteria A: There was no change operated with initial operating during the test.
- 4) Criteria B: The EUT function loss during the test, but self-recoverable after the test.
- 5) Criteria C: The system shut down during the test.



5.7 SURGE TESTING

5.7.1 TEST SPECIFICATION

Basic Standard:	IEC/EN 61000-4-5
Required Performance	B
Wave-Shape:	Combination Wave 1.2/50 us Open Circuit Voltage 8 /20 us Short Circuit Current
Test Voltage :	Power Line : 0.5 kV, 1 kV, 2 kV
Surge Input/Output:	L1-L2, L1-PE, L2-PE
Generator Source:	2 ohm between networks
Impedance:	12 ohm between network and ground
Polarity:	Positive/Negative
Phase Angle:	0 /90/180/270
Pulse Repetition Rate:	1 time / min. (maximum)
Number of Tests:	5 positive and 5 negative at selected points

5.7.2 MEASUREMENT INSTRUMENTS

Item	Kind of Equipment	Manufacturer	Type No.	Serial No.	Calibrated until
1	EMC Immunity Test System	Thermo	EMC PRO PLUS	0502176	Mar. 04,2011
2	Measurement Software	KeyTek	CEWare32 (Version 4.00)	N/A	N/A

Remark: " N/A" denotes No Model Name / Serial No. and No Calibration specified.

5.7.3 TEST PROCEDURE

a. For EUT power supply:

The surge is to be applied to the EUT power supply terminals via the capacitive coupling network. Decoupling networks are required in order to avoid possible adverse effects on equipment not under test that may be powered by the same lines, and to provide sufficient decoupling impedance to the surge wave. The power cord between the EUT and the coupling/decoupling networks shall be 2meters in length (or shorter).

b. For test applied to unshielded unsymmetrically operated interconnection lines of EUT:

The surge is applied to the lines via the capacitive coupling. The coupling /decoupling networks shall not influence the specified functional conditions of the EUT. The interconnection line between the EUT and the coupling/decoupling networks shall be 2 meters in length (or shorter).

c. For test applied to unshielded symmetrically operated interconnection /telecommunication lines of EUT:

The surge is applied to the lines via gas arrestors coupling. Test levels below the ignition point of the coupling arrestor cannot be specified. The interconnection line between the EUT and the coupling/decoupling networks shall be 2 meters in length (or shorter).

d. For the actual test configuration, please refer to the related Item –EUT Test Photos.



5.7.4 DEVIATION FROM TEST STANDARD

No deviation

5.7.5 TEST SETUP

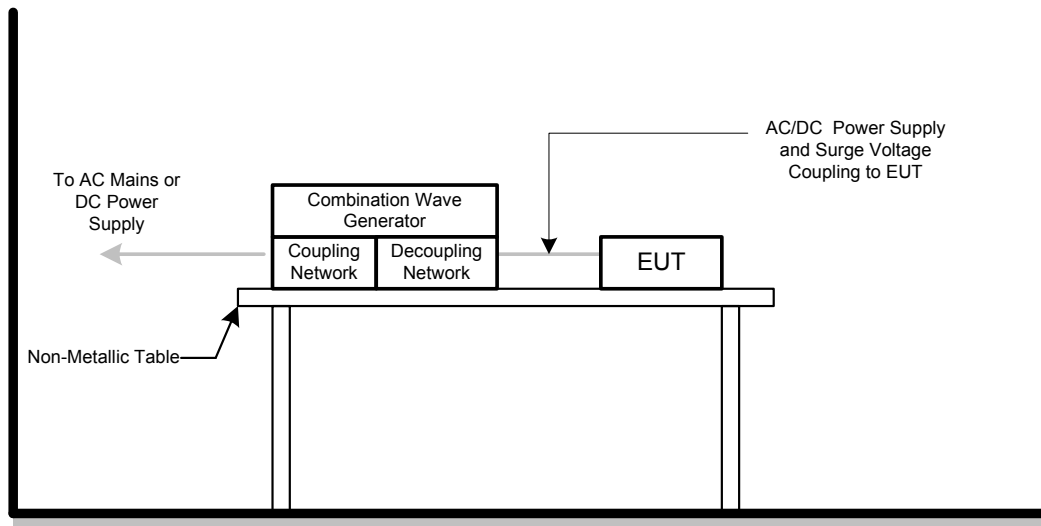



5.7.6 TEST RESULTS

E.U.T :	Flexible Embedded System	Model Name :	FES-6110
Temperature :	22	Relative Humidity :	47
Test Voltage :	AC 230V/50Hz		
Test Mode :	FULL SYSTEM D-SUB+DVI 1600*1200/60Hz (FES-6110)		

Wave Form EUT Ports Tested		1.2/50(8/20)Ti/Th us						Criteria	Judgment
		Polarity	Phase	Voltage					
				0.5kV	1kV	2kV	4kV		
AC	L – N (2 ohm)	+/-	0°	A	A			B	PASS
		+/-	90°	A	A				
		+/-	180°	A	A				
		+/-	270°	A	A				
	L – PE (12 ohm)	+/-	0°	A	A	A		B	PASS
		+/-	90°	A	A	A			
		+/-	180°	A	A	A			
		+/-	270°	A	A	A			
	N – PE (12 ohm)	+/-	0°	A	A	A		B	PASS
		+/-	90°	A	A	A			
		+/-	180°	A	A	A			
		+/-	270°	A	A	A			
DC	L – PE (12 ohm)	+/-	N/A					B	N/A
Signal Line	N/A (42 ohm)	+/-	N/A					B	N/A

Note:

- 1) Polarity and Numbers of Impulses : 5 Pst / Ngt at each tested mode
- 2) N/A - denotes test is not applicable in this Test Report
- 3) Criteria A: There was no change operated with initial operating during the test.
- 4) Criteria B: The EUT function loss during the test, but self-recoverable after the test.
- 5) Criteria C: The system shut down during the test.



5.8 INJECTION CURRENT TESTING

5.8.1 TEST SPECIFICATION

Basic Standard:	IEC/EN 61000-4-6
Required Performance	A
Frequency Range:	0.15 MHz - 80 MHz
Field Strength:	3 Vr.m.s.
Modulation:	1kHz Sine Wave, 80%, AM Modulation
Frequency Step:	1% of fundamental
Dwell Time:	at least 3 seconds

5.8.2 MEASUREMENT INSTRUMENTS

Item	Kind of Equipment	Manufacturer	Type No.	Serial No.	Calibrated until
1	Signal Generator	IFR	2023A	202301/368	Apr. 06, 2011
2	Power Amplifier	AR	75A250AM1	0320709	Sep. 23, 2010
3	CDN (M3)	FCC	FCC-801-M2/M3-16A	06043	Jun. 02, 2010
4	EM Clamp	FCC	F-203I-23MM	504	Jun. 02, 2010
5	Measurement Software	AR	SW1006 (Version 1.1)	321778	N/A

Remark: " N/A" denotes No Model Name / Serial No. and No Calibration specified.

5.8.3 TEST PROCEDURE

The EUT and support equipment, are placed on a table that is 0.8 meter above a metal ground plane measured 1m*1m min. and 0.65mm thick min.

The other condition as following manner:

- a. The field strength level was 3V.
- b. The frequency range is swept from 150 KHz to 80 MHz, with the signal 80%amplitude modulated with a 1kHz sine wave. The rate of sweep did not exceed 1.5×10^{-3} decade/s. Where the frequency range is swept incrementally, the step size was 1% of fundamental.
- c. The dwell time at each frequency shall be not less than the time necessary for the EUT to be able to respond.
- d. For the actual test configuration, please refer to the related Item –EUT Test Photos.

5.8.4 DEVIATION FROM TEST STANDARD

No deviation

5.8.5 TEST SETUP

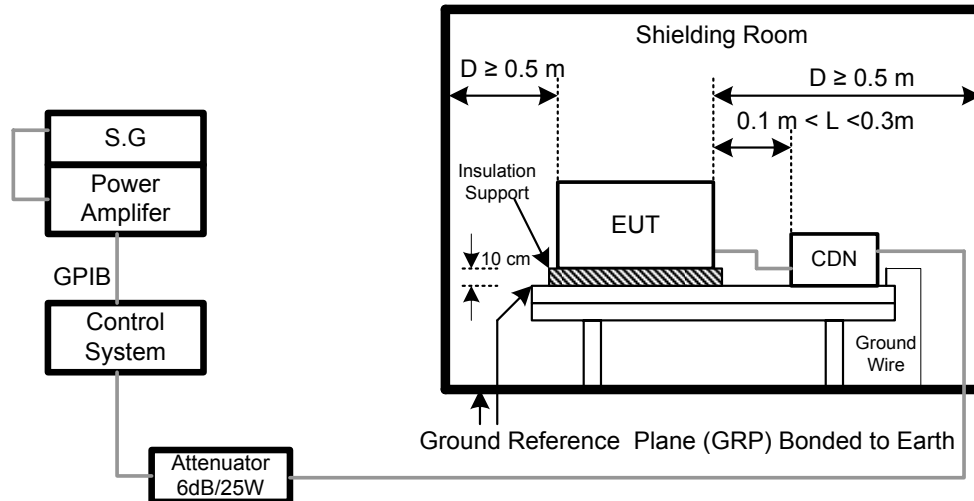

For the actual test configuration, please refer to the related Item –EUT Test Photos.

NOTE:

FLOOR-STANDING EQUIPMENT

The equipment to be tested is placed on an insulating support of 0.1 meters height above a ground reference plane. All relevant cables shall be provided with the appropriate coupling and decoupling devices at a distance between 0.1 meters and 0.3 meters from the projected geometry of the EUT on the ground reference plane.



5.8.6 TEST RESULTS

E.U.T :	Flexible Embedded System	Model Name :	FES-6110
Temperature :	22 °C	Relative Humidity :	47%
Test Voltage :	AC 230V/50Hz		
Test Mode :	FULL SYSTEM D-SUB+DVI 1600*1200/60Hz (FES-6110)		

Test Ports (Mode)	Freq. Range (MHz)	Field Strength	Perform. Criteria	Results	Judgment
Input/ Output AC. Power Port	0.15 ---80	3V(rms) AM Modulated 1000Hz, 80%	A	A	PASS
Input/ Output DC. Power Port	0.15 --- 80		A	N/A	N/A
Signal Line (RJ-45)	0.15 --- 80		A	A	PASS

Note:

- 1) N/A - denotes test is not applicable in this Test Report.
- 2) Criteria A: There was no change operated with initial operating during the test.
- 3) Criteria B: The EUT function loss during the test, but self-recoverable after the test.
- 4) Criteria C: The system shut down during the test.



5.9 POWER FREQUENCY MAGNETIC FIELD TESTING

5.9.1 TEST SPECIFICATION

Basic Standard:	IEC/EN 61000-4-8
Required Performance	A
Frequency Range:	50Hz
Field Strength:	1 A/m
Observation Time:	1 minute
Inductance Coil:	Rectangular type, 1mx1m

5.9.2 MEASUREMENT INSTRUMENTS

Item	Kind of Equipment	Manufacturer	Type No.	Serial No.	Calibrated until
1	Magnetic Field Test Generator	FCC	F-1000-4-8-G-1 25A	04029	Sep. 24, 2010
2	Magnetic Field Immunity Loop	FCC	F-1000-4-8/9/10-L -1M	04018	Sep. 24, 2010
3	Triaxial ELF Magnetic Field Meter	F.W. BELL	4190	0845014	Sep. 24, 2010

Remark: " N/A" denotes No Model Name / Serial No. and No Calibration specified.

5.9.3 TEST PROCEDURE

The EUT and support equipment, are placed on a table that is 0.8 meter above a metal ground plane measured 1m*1m min. and 0.65mm thick min.

The other condition as following manner:

- a. The equipment cabinets shall be connected to the safety earth directly on the GRP via the earth terminal of the EUT.
- b. The cables supplied or recommended by the equipment manufacturer shall be used. 1 meter of all cables used shall be exposed to the magnetic field.
- c. For the actual test configuration, please refer to the related Item –EUT Test Photos.

5.9.4 DEVIATION FROM TEST STANDARD

No deviation

5.9.5 TEST SETUP

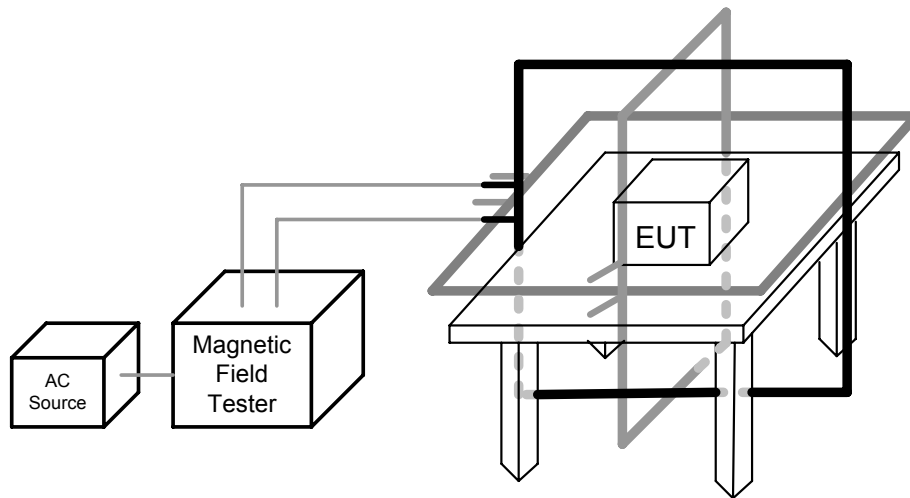

Note:

TABLE-TOP EQUIPMENT

The equipment shall be subjected to the test magnetic field by using the induction coil of standard dimension (1 m x 1 m). The induction coil shall then be rotated by 90 degrees in order to expose the EUT to the test field with different orientations.

FLOOR-STANDING EQUIPMENT

The equipment shall be subjected to the test magnetic field by using induction coils of suitable dimensions. The test shall be repeated by moving and shifting the induction coils, in order to test the whole volume of the EUT for each orthogonal direction. The test shall be repeated with the coil shifted to different positions along the side of the EUT, in steps corresponding to 50% of the shortest side of the coil. The induction coil shall then be rotated by 90 degrees in order to expose the EUT to the test field with different orientations.



5.9.6 TEST RESULTS

E.U.T :	Flexible Embedded System	Model Name :	FES-6110
Temperature :	22 °C	Relative Humidity :	47%
Test Voltage :	AC 230V/50Hz		
Test Mode :	FULL SYSTEM D-SUB+DVI 1600*1200/60Hz (FES-6110)		

Test Mode	Test Level	Antenna aspect	Duration (s)	Perform Criteria	Results	Judgment
Enclosure	1 A/m	X	60 s	A	A	PASS
Enclosure	1 A/m	Y	60 s	A	A	PASS
Enclosure	1 A/m	Z	60 s	A	A	PASS

Note:

- 1) N/A - denotes test is not applicable in this test report
- 2) Criteria A: There was no change operated with initial operating during the test.
- 3) Criteria B: The EUT function loss during the test, but self-recoverable after the test.
- 4) Criteria C: The system shut down during the test.



5.10 VOLTAGE INTERRUPTION/DIPS TESTING

5.10.1 TEST SPECIFICATION

Basic Standard:	IEC/EN 61000-4-11
Required Performance	B (For >95% Voltage Dips) C (For 30% Voltage Dips) C (For >95% Voltage Interruptions)
Test Duration Time:	Minimum three test events in sequence
Interval between Event:	Minimum ten seconds
Phase Angle:	0°/45°/90°/135°/180°/225°/270°/315°/360°
Test Cycle:	3 times

5.10.2 MEASUREMENT INSTRUMENTS

Item	Kind of Equipment	Manufacturer	Type No.	Serial No.	Calibrated until
1	EMC Immunity Test System	Thermo	EMC PRO PLUS	0502176	Mar. 04, 2011
2	Measurement Software	KeyTek	CEWare32 (Version 4.00)	N/A	N/A

Remark: " N/A " denotes No Model Name / Serial No. and No Calibration specified.

5.10.3 TEST PROCEDURE

The EUT shall be tested for each selected combination of test levels and duration with a sequence of three dips/interruptions with intervals of 10 s minimum (between each test event). Each representative mode of operation shall be tested. Abrupt changes in supply voltage shall occur at zero crossings of the voltage waveform.

5.10.4 DEVIATION FROM TEST STANDARD

No deviation



5.10.5 TEST SETUP

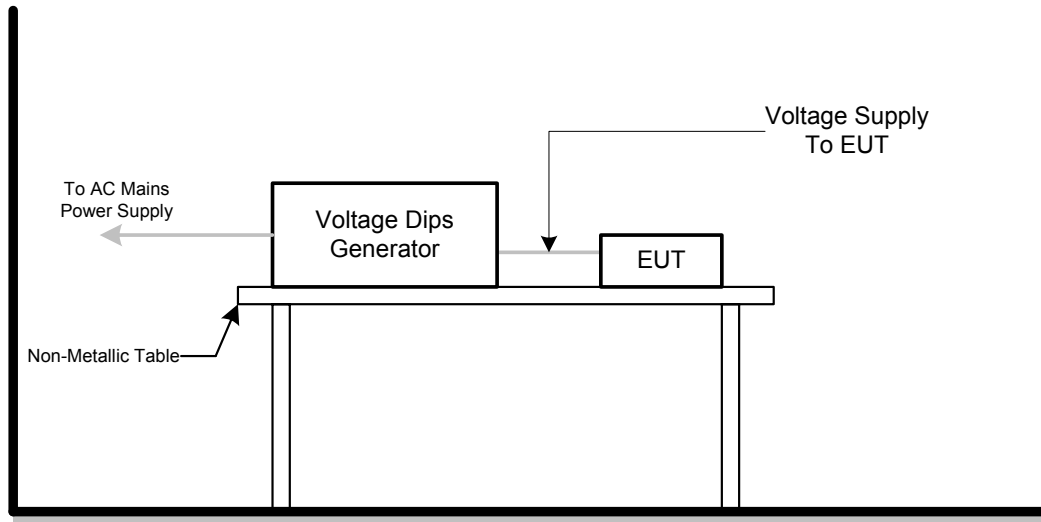

For the actual test configuration, please refer to the related Item –EUT Test Photos.



5.10.6 TEST RESULTS

E.U.T :	Flexible Embedded System	Model Name :	FES-6110
Temperature :	22 °C	Relative Humidity :	47%
Test Voltage :	AC 230V/50Hz		
Test Mode :	FULL SYSTEM D-SUB+DVI 1600*1200/60Hz (FES-6110)		

AC 100V/50Hz				
Voltage Reduction	Duration (Periods)	Perform Criteria	Results	Judgment
Voltage dip >95%	0.5	B	A	PASS
Voltage dip 30%	25	C	A	PASS
Interruption >95%	250	C	C	PASS

AC 230V/50Hz				
Voltage Reduction	Duration (Periods)	Perform Criteria	Results	Judgment
Voltage dip >95%	0.5	B	A	PASS
Voltage dip 30%	25	C	A	PASS
Interruption >95%	250	C	C	PASS

AC 240V/50Hz				
Voltage Reduction	Duration (Periods)	Perform Criteria	Results	Judgment
Voltage dip >95%	0.5	B	A	PASS
Voltage dip 30%	25	C	A	PASS
Interruption >95%	250	C	C	PASS

Note:

- 1). N/A - denotes test is not applicable in this test report.
- 2) Criteria A: There was no change operated with initial operating during the test.
- 3) Criteria B: The EUT function loss during the test, but self-recoverable after the test.
- 4) Criteria C: The system shut down during the test.



6. EUT TEST PHOTO

Conducted Measurement Photos





**Radiated Measurement Photos
BETWEEN 30MHZ AND 1000MHZ**



Radiated Measurement Photos

ABOVE 1000MHZ

