



CE EMC TEST REPORT

for

Robust Panel PC

MODEL: xxxxxAPC-9172HTy-xx-xxxx

Test Report Number:
70427205-E

Issued to:

AAEON Technology Inc.

**5F, No.135, Lane 235, Pao Chiao Rd., Hsin-Tien City,
Taipei, Taiwan, R.O.C.**

Issued by:

Compliance Certification Services Inc.

Sindian BU

**No.163-1, Jhongsheng Rd., Sindian City,
Taipei County 23151, Taiwan**

TEL: 886-2-22170894

FAX: 886-2-22171029

Issued Date: May 4, 2007



Note: This report shall not be reproduced except in full, without the written approval of Compliance Certification Services Inc. This document may be altered or revised by Compliance Certification Services Inc. personnel only, and shall be noted in the revision section of the document. The client should not use it to claim product endorsement by TAF, A2LA, NVLAP, NIST or any government agencies. The test results in the report only apply to the tested sample.



Revision History

Rev.	Issue Date	Revisions	Effect Page	Revised By
00		Initial Issue	ALL	



TABLE OF CONTENTS

1 TEST CERTIFICATION4

2 TEST RESULT SUMMARY.....5

3 EUT DESCRIPTION6

4 TEST METHODOLOGY.....7

4.1. DECISION OF FINAL TEST MODE7

4.2. EUT SYSTEM OPERATION7

5 SETUP OF EQUIPMENT UNDER TEST.....8

5.1. DESCRIPTION OF SUPPORT UNITS8

5.2. CONFIGURATION OF SYSTEM UNDER TEST10

6 FACILITIES AND ACCREDITATIONS.....11

6.1. FACILITIES11

6.2. ACCREDITATIONS.....11

6.3. MEASUREMENT UNCERTAINTY11

7 EMISSION TEST.....12

7.1. CONDUCTED EMISSION MEASUREMENT12

7.2. CONDUCTED EMISSION MEASUREMENT AT TELECOMMUNICATION PORTS .16

7.3. RADIATED EMISSION MEASUREMENT.....20

7.4. HARMONICS CURRENT MEASUREMENT.....26

7.5. VOLTAGE FLUCTUATION AND FLICKER MEASUREMENT.....32

8 IMMUNITY TEST.....36

8.1. GENERAL DESCRIPTION.....36

8.2. GENERAL PERFORMANCE CRITERIA DESCRIPTION.....37

8.3. ELECTROSTATIC DISCHARGE (ESD)38

8.4. RADIATED, RADIO-FREQUENCY, ELECTROMAGNETIC FIELD (RS)45

8.5. ELECTRICAL FAST TRANSIENT (EFT)49

8.6. SURGE IMMUNITY TEST52

8.7. CONDUCTED RADIO FREQUENCY DISTURBANCES (CS)56

8.8. POWER FREQUENCY MAGNETIC FIELD.....60

8.9. VOLTAGE DIP & VOLTAGE INTERRUPTIONS.....63

9 PHOTOGRAPHS OF THE TEST CONFIGURATION66



1 TEST CERTIFICATION

Product: Robust Panel PC
Model: xxxxxAPC-9172HTy-xx-xxxx(Where y is T or blank and x is 0-9, A-Z, - or blank)
Brand: AAEON

Applicant: AAEON Technology Inc.
 5F, No.135, Lane 235, Pao Chiao Rd., Hsin-Tien City,
 Taipei, Taiwan, R.O.C.

Manufacturer: AAEON Technology Inc.
 5F, No.135, Lane 235, Pao Chiao Rd., Hsin-Tien City,
 Taipei, Taiwan, R.O.C.

Tested: April 27, 2007 & May 2, 2007

Applicable Standards:	EN 55022: 1998 + A1: 2000 + A2: 2003, Class A	EN 55024: 1998 + A1: 2001 + A2: 2003
	EN 61000-3-2: 2000	IEC 61000-4-2: 1995 + A1: 1998 + A2: 2000
	EN 61000-3-3: 1995 + A1: 2001	IEC 61000-4-3: 2002 + A1: 2002
		IEC 61000-4-4: 2004
		IEC 61000-4-5: 1995 + A1: 2000
		IEC 61000-4-6: 1996 + A1: 2000
		IEC 61000-4-8: 1993 + A1: 2000
		IEC 61000-4-11: 2004

Deviation from Applicable Standard
None

The above equipment has been tested by Compliance Certification Services Inc., and found compliance with the requirements set forth in the technical standards mentioned above. The results of testing in this report apply only to the product/system, which was tested. Other similar equipment will not necessarily produce the same results due to production tolerance and measurement uncertainties.

Approved by:

Reviewed by:



David Wang
 Manager of SIndian BU



Vince Chiang
 Assistant Manager of SIndian BU



2 TEST RESULT SUMMARY

EMISSION			
Standard	Item	Result	Remarks
EN 55022: 1998 + A1: 2000 + A2: 2003	Conducted (Main Port)	PASS	Meet Class A limit
	Conducted (Telecom port)	PASS	Meet Class A limit
	Radiated	PASS	Meet Class A limit
EN 61000-3-2 (2000)	Harmonic current emissions	PASS	Meet Class D limit
EN 61000-3-3 (1995) + A1 (2001)	Voltage fluctuations & flicker	PASS	Meets the requirements

IMMUNITY [EN 55024 (1998 + A1: 2001 + A2: 2003)]			
Standard	Item	Result	Remarks
IEC 61000-4-2: 1995 + A1: 1998 + A2: 2000	ESD	PASS	Meets the requirements of Performance Criterion B
IEC 61000-4-3: 2002 + A1: 2002	RS	PASS	Meets the requirements of Performance Criterion A
IEC 61000-4-4: 2004	EFT	PASS	Meets the requirements of Performance Criterion B
IEC 61000-4-5: 1995 + A1: 2000	Surge	PASS	Meets the requirements of Performance Criterion B
IEC 61000-4-6: 1996 + A1: 2000	CS	PASS	Meets the requirements of Performance Criterion A
IEC 61000-4-8:1993 + A1: 2000	PFMF	N/A	Please see the page 62
IEC 61000-4-11: 2004	Voltage dips & voltage variations	PASS	Meets the requirements of Voltage Dips: 1) >95% reduction Performance Criterion B 2) 30% reduction Performance Criterion C Voltage Interruptions: 1) >95% reduction Performance Criterion C.

- Note:**
1. The test result judgment is decided by the limit of test standard
 2. The information of measurement uncertainty is available upon the customer's request.



3 EUT DESCRIPTION

Product	Robust Panel PC
Brand Name	AAEON
Model	xxxxxAPC-9172HTy-xx-xxxx(Where y is T or blank and x is 0-9, A-Z, - or blank)
Test Item	Engineering Sample
Applicant	AAEON Technology Inc.
Housing material	Metal Case
EUT Type	<input checked="" type="checkbox"/> Engineering Sample. <input type="checkbox"/> Product Sample. <input type="checkbox"/> Mass Product Sample.
Serial Number	N/A
Received Date	April 27, 2007
EUT Power Rating	100-240VAC, 50-60Hz
AC Power During Test	230VAC / 50Hz
Power Supply Manufacturer	FSP
Power Supply ModelNumber	FSP250-50PLB
OSC/Clock Frequencies	14.31818MHz; 25MHz; 32.768KHz

I/O PORT

I/O PORT TYPES	Q' TY	TESTED WITH
1. PIO Port	1	1
2. SIO Port	4	4
3. PS/2 Keyboard Port	1	1
4. PS/2 Mouse Port	1	1
5. Video Out Port (VGA)	1	1
6. Audio In Port	1	1
7. Microphone Port	1	1
8. Earphone Port	1	1
9. LAN Port	2	2
10. USB Port	5	5
11. CF/ SM/ MS/ SD Slot	1/ 1/ 1/ 1	1/ 1/ 1/ 1

Note: Client consigns only one model sample to test (Model Number: APC-9172).

4 TEST METHODOLOGY

4.1. DECISION OF FINAL TEST MODE

The EUT was tested together with the above additional components, and a configuration, which produced the worst emission levels, was selected and recorded in this report.

The test configuration/ mode is as the following:

Mode:

1. Normal Mode

Conduction: Mode 1

Radiation: Mode 1

4.2. EUT SYSTEM OPERATION

1. Windows XP boots system.
2. Run Emctest.exe to activate all peripherals and display “H” pattern on monitor screen.
3. Run media player to play music.
4. Run Winemc.exe and choose “E:/ & F:/ & G:/ & H:/ & I:/ & J:/ & K:/ & L:/ & N:/” to test EUT.
5. Press the start menu, select executive and type ping 192.168.0.2-t (EUT), ping 192.168.0.1 -t (Server Notebook).
6. Press the start menu, select executive and type ping 192.168.1.2-t (EUT), ping 192.168.1.1 -t (Server Notebook).

Note: Test program is self-repeating throughout the test.



5 SETUP OF EQUIPMENT UNDER TEST

5.1. DESCRIPTION OF SUPPORT UNITS

The EUT has been tested as an independent unit together with other necessary accessories or support units. The following support units or accessories were used to form a representative test configuration during the tests.

EUT Devices:

No.	Equipment	Model No.	Trade Name
1	RAM (512MB / DDR2)	E5108AG-6E-E	ELPIDA
2	CPU (1.66GHz)	T5500	Intel(R)Core 2
3	SATA HDD (80GB)	MHV2080BH	FUJITSU
4	Power Supply	FSP250-50PLB	FSP
5	DVD ROM	DV-28SL-R93	TEAC

**Peripherals Devices:**

No.	Equipment	Model No.	Serial No.	FCC ID/ BSMI ID	Trade Name	Data Cable	Power Cord
1	Earphone & Microphone	MSB301	N/A	N/A	e-Sense	Unshielded, 1.8m	N/A
2	Player	RQ-L11LT	N/A	BSMI ID: 3912A162	Panasonic	Unshielded, 1.4m	N/A
3	USB HDD	F12-U	N/A	BSMI ID: 4912A002	TeraSys	Shielded, 1.8m	N/A
4	PS/2 Mouse	M071KC	443029438	DOC / BSMI: R41108	DELL	Shielded, 1.8m	N/A
5	PS/2 Keyboard	SK-8110	N/A	DOC / BSMI: T3A002	DELL	Shielded, 1.8m	N/A
6	USB HDD	F12-U	N/A	BSMI ID: 4912A002	TeraSys	Shielded, 1.8m	N/A
7	USB HDD	F12-U	N/A	BSMI ID: 4912A002	TeraSys	Shielded, 1.8m	N/A
8	USB HDD	F12-U	N/A	BSMI ID: 4912A002	TeraSys	Shielded, 1.8m	N/A
9	USB HDD	F12-U	N/A	BSMI ID: 4912A002	TeraSys	Shielded, 1.8m	N/A
10	Printer	C60	N/A	BSMI ID: 3902E006	EPSON	Shielded, 1.8m	Unshielded, 1.8m
11	Monitor	710V	GS17H9NXA05855D	DOC / BSMI: R33475	SAMSUNG	Shielded, 1.8m with two cores	Unshielded, 1.8m
12	Modem	5JEG4033MKO	N/A	5RJTAI-35500-M5-E	TOP-SOLUTION	Shielded, 1.6m	Unshielded, 1.8m
13	Modem	1414	N/A	IFAXDM1414	ACEEX	Shielded, 1.6m	Unshielded, 1.8m
14	Modem	1414	N/A	IFAXDM1414	ACEEX	Shielded, 1.6m	Unshielded, 1.8m
15	Modem	1414	N/A	IFAXDM1414	ACEEX	Shielded, 1.6m	Unshielded, 1.8m
16	Server Notebook	M623	N/A	N/A	Fox	Unshielded, 20m	Unshielded, 1.8m
17	Server Notebook	PP05L	2464936188	DOC / BSMI: R33002	DELL	Unshielded, 20m	Unshielded, 1.8m
18	CF Card	N/A	N/A	N/A	N/A	N/A	N/A
19	SD Card	N/A	N/A	N/A	N/A	N/A	N/A
20	MS Card	N/A	N/A	N/A	N/A	N/A	N/A
21	SM Card	N/A	N/A	N/A	N/A	N/A	N/A

Note:

- 1) All the equipment/cables were placed in the worst-case configuration to maximize the emission during the test.
- 2) Grounding was established in accordance with the manufacturer's requirements and conditions for the intended use.

5.2. CONFIGURATION OF SYSTEM UNDER TEST

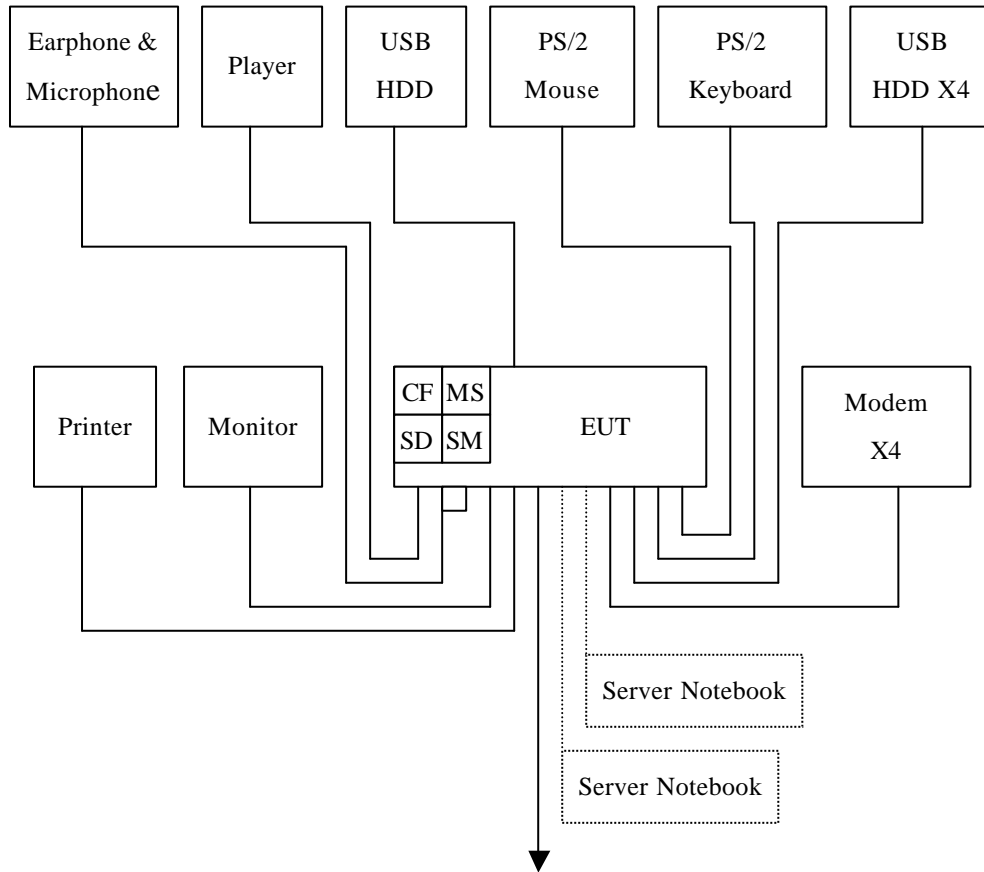

6 FACILITIES AND ACCREDITATIONS

6.1. FACILITIES

All measurement facilities used to collect the measurement data are located at CCS Taiwan Sindian BU at No.163-1, Jhongsheng Rd., Sindian City, Taipei County 23151, Taiwan.

The sites are constructed in conformance with the requirements of ANSI C63.4 and CISPR Publication 22. All receiving equipment conforms to CISPR Publication 16-1, "Radio Interference Measuring Apparatus and Measurement Methods."

6.2. ACCREDITATIONS

Our laboratories are accredited and approved by the following approval agencies according to ISO/IEC 17025.

USA	FCC, A2LA
Germany	TUV Rheinland
Japan	VCCI
Norway	NEMKO
Canada	INDUSTRY CANADA
Taiwan	TAF, BSMI

Copies of granted accreditation certificates are available for downloading from our web site, <http://www.ccsemc.com.tw>

6.3. MEASUREMENT UNCERTAINTY

Where relevant, the following measurement uncertainty levels have been estimated for tests performed on the EUT as specified in CISPR 16-4-2:

Measurement	Frequency	Uncertainty	
Conducted emissions	9kHz~30MHz	± 3.4508	
Radiated emissions	Horizontal	30MHz ~ 200MHz	± 4.3799
		200MHz ~1000MHz	± 4.5147
	Vertical	30MHz ~ 200MHz	± 4.5015
		200MHz ~1000MHz	± 4.5073

This uncertainty represents an expanded uncertainty expressed at approximately the 95% confidence level using a coverage factor of k=2.



7 EMISSION TEST

7.1. CONDUCTED EMISSION MEASUREMENT

7.1.1. LIMITS

FREQUENCY (MHz)	Class A (dBuV)		Class B (dBuV)	
	Quasi-peak	Average	Quasi-peak	Average
0.15 - 0.5	79	66	66 - 56	56 - 46
0.50 - 5.0	73	60	56	46
5.0 - 30.0	73	60	60	50

NOTE:

- (1) The lower limit shall apply at the transition frequencies.
- (2) The limit decreases in line with the logarithm of the frequency in the range of 0.15 to 0.50 MHz.
- (3) All emanations from a class A/B digital device or system, including any network of conductors and apparatus connected thereto, shall not exceed the level of field strengths specified above.

7.1.2. TEST INSTRUMENTS

Conducted Emission room # A				
Name of Equipment	Manufacturer	Model	Serial Number	Calibration Due
TEST RECEIVER	R&S	ESHS20	840455/006	02/12/2008
LISN (EUT)	SCHWARZBECK	NSLK 8127	8127382	12/06/2007
LISN	SOLAR	8012-50-R-24-BNC	8305114	12/26/2007
BNC CABLE	JYE BAO	RG-223/U	BNC A 2	10/10/2007
THERMO-HYGRO METER	TOP	HA-202	9303-1	02/04/2008
Test S/W	EMI 32.exe			

- NOTE:** 1. The calibration interval of the above test instruments is 12 months and the calibrations are traceable to NML/ROC and NIST/USA.
 2. N.C.R = No Calibration Request.



7.1.3. TEST PROCEDURES (please refer to measurement standard or CCS SOP PA-031)

Procedure of Preliminary Test

- The EUT and Support equipment, if needed, was set up as per the test configuration to simulate typical usage per the user's manual. When the EUT is a tabletop system, a wooden table with a height of 0.8 meters is used and is placed on the ground plane as per EN 55022 (see Test Facility for the dimensions of the ground plane used). When the EUT is a floor standing equipment, it is placed on the ground plane, which has a 3-12 mm non-conductive covering to insulate the EUT from the ground plane.
- All I/O cables were positioned to simulate typical actual usage as per EN 55022.
- The test equipment EUT installed received AC main power, through a Line Impedance Stabilization Network (LISN), which supplied power source and was grounded to the ground plane.
- All support equipment power received from a second LISN.
- The EUT test program was started. Emissions were measured on each current carrying line of the EUT using an EMI Test Receiver connected to the LISN powering the EUT.
- The Receiver scanned from 150kHz to 30MHz for emissions in each of the test modes.
- During the above scans, the emissions were maximized by cable manipulation.
- The test mode(s) described in Item 3.1 were scanned during the preliminary test.
- After the preliminary scan, we found the test mode described in Item 3.1 producing the highest emission level.
- The EUT configuration and cable configuration of the above highest emission levels were recorded for reference of the final test.

Procedure of Final Test

- EUT and support equipment were set up on the test bench as per the configuration with highest emission level in the preliminary test.
- A scan was taken on both power lines, Line 1 and Line 2, recording at least the six highest emissions. Emission frequency and amplitude were recorded into a computer in which correction factors were used to calculate the emission level and compare reading to the applicable limit.
- The test data of the worst-case condition(s) was recorded.

7.1.4. TEST SETUP

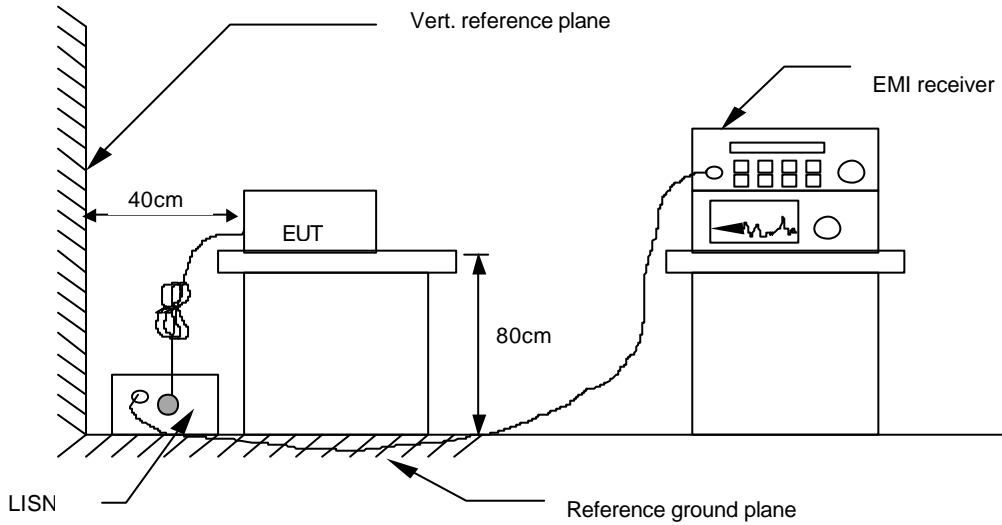

- For the actual test configuration, please refer to the related item – Photographs of the Test Configuration.

7.1.5. DATA SAMPLE

Freq. MHz	Read Level dBuV	Factor dB	Level dBuV	Limit dBuV	Over Limit dB	Reading Type (P/Q/A)	Line (L1/L2)
x.xx	42.95	0.55	43.50	73	-29.50	Q	L1

- Freq. = Emission frequency in MHz
- Read Level = Uncorrected Analyzer/Receiver reading
- Factor = Insertion loss of LISN + Cable Loss
- Level = Read Level + Factor
- Limit = Limit stated in standard
- Over Limit = Reading in reference to limit
- P = Peak Reading
- Q = Quasi-peak Reading
- A = Average Reading
- L1 = Hot side
- L2 = Neutral side

Calculation Formula

Over Limit (dB) = Level (dBuV) – Limit (dBuV)



7.1.6. TEST RESULTS

Model No.	APC-9172	6dB Bandwidth	10 KHz
Environmental Conditions	25deg.C, 55% RH, 1010 hPa	Test Mode	Mode 1
Tested by	James Hsieh		

(The chart below shows the highest readings taken from the final data.)

Six Highest Conducted Emission Readings							
Frequency Range Investigated				150 KHz to 30 MHz			
Freq (MHz)	Read Level (dBuV)	Factor (dB)	Level (dBuV)	Limit Line (dBuV)	Over Limit (dB)	Reading Type (P/Q/A)	Line (L1/L2)
8.279	37.37	1.08	38.46	73.00	-34.54	P	L1
9.966	36.92	1.16	38.08	73.00	-34.92	P	L1
24.015	45.12	1.97	47.09	73.00	-25.91	P	L1
11.498	44.60	0.84	45.44	73.00	-27.56	P	L2
20.377	41.50	1.47	42.97	73.00	-30.03	P	L2
24.922	41.59	1.71	43.29	73.00	-29.71	P	L2

NOTE: 1. L1 = Line One (Live Line) / L2 = Line Two (Neutral Line)

2. The emission level was or more than 2dB below the Average limit, so no re-check anymore.

7.2. CONDUCTED EMISSION MEASUREMENT AT TELECOMMUNICATION PORTS

7.2.1. LIMITS

For Class A Equipment

FREQUENCY (MHz)	Voltage Limit (dBuV)		Current Limit (dBuA)	
	Quasi-peak	Average	Quasi-peak	Average
0.15 ~ 0.5	97 ~ 87	84 ~ 74	53 ~ 43	40 ~ 30
0.5 ~ 30.0	87	74	43	30

NOTE: The limits decrease linearly with the logarithm of the frequency in the range 0.15 MHz to 0.5 MHz.

For Class B Equipment

FREQUENCY (MHz)	Voltage Limit (dBuV)		Current Limit (dBuA)	
	Quasi-peak	Average	Quasi-peak	Average
0.15 - 0.5	84 ~ 74	74 ~ 64	40 ~ 30	30 ~ 20
0.5 - 30.0	74	64	30	20

NOTE:

1. The limits decrease linearly with the logarithm of the frequency in the range 0,15 MHz to 0,5 MHz.
2. Provisionally, a relaxation of 10 dB over the frequency range of 6 MHz to 30 MHz is allowed for high-speed services having significant spectral density in this band. However, this relaxation is restricted to the common mode disturbance converted by the cable from the wanted signal.



7.2.2. TEST INSTRUMENTS

Conducted Emission room # A				
Name of Equipment	Manufacturer	Model	Serial Number	Calibration Due
TEST RECEIVER	R&S	ESHS20	840455/006	02/12/2008
LISN (EUT)	SCHWARZBECK	NSLK 8127	8127382	12/06/2007
LISN	SOLAR	8012-50-R-24-BNC	8305114	12/26/2007
BNC CABLE	JYE BAO	RG-223/U	BNC A2	10/10/2007
THERMO-HYGRO METER	TOP	HA-202	9303-1	02/04/2008
ISN	FCC	FCC-TLISN-T4	20166	07/12/2007
ISN	FCC	FCC-TLISN-T8-02	20169	07/12/2007
Test S/W	EMI 32.exe			

NOTE: 1. The calibration interval of the above test instruments is 12 months and the calibrations are traceable to NML/ROC and NIST/USA.
 2. N.C.R = No Calibration Request.

7.2.3. TEST PROCEDURE (please refer to measurement standard or CCS SOP PA-031)

- Selecting ISN for unscreened cable or a current probe for screened cable to take measurement.
- The port of the EUT was connected to the remote side support equipment through the ISN/Current Probe and communication in normal condition.
- Making a overall range scan by using the test receiver controlled by controller and record at least six highest emissions for showing in the test report.
- Emission frequency and amplitude were recorded into a computer in which correction factors were used to calculate the emission level and compare reading to the applicable limit.
- In case of measuring on the screened cable, the current limit shall be applied; otherwise the voltage limit should be applied.
- The following test mode was scanned during the preliminary test:

Mode(s):

1.	LAN 1	1 Gbps
2.	LAN 2	1 Gbps
3.		100 Mbps
4.		10 Mbps

- After the preliminary scan, we found the following test mode(s) producing the highest emission level and test data of the worst case was recorded.

Mode: 2.

7.2.4. TEST SETUP

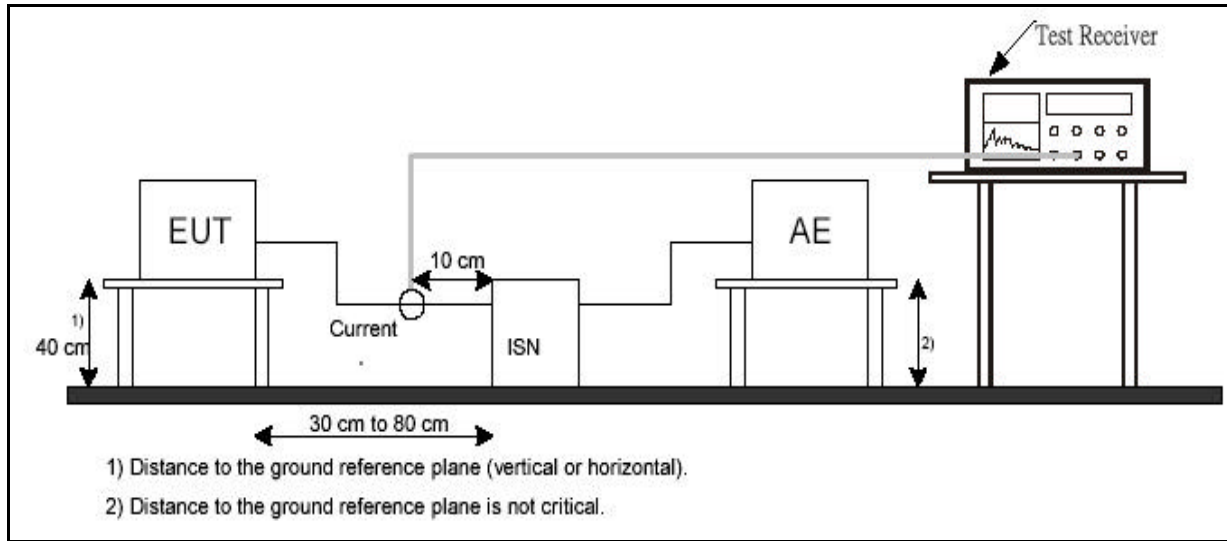

- For the actual test configuration, please refer to the related item – Photographs of the Test Configuration.

7.2.5. DATA SAMPLE

Freq. MHz	Read Level dBuV	Factor dB	Level dBuV	Limit dBuV	Over Limit dB	Reading Type (P/Q/A)
x.xx	62.95	0.55	63.50	87	-23.50	Q

- Freq. = Emission frequency in MHz
- Read Level = Uncorrected Analyzer/Receiver reading
- Factor = Insertion loss of ISN + Cable Loss
- Level = Read Level + Factor
- Limit = Limit stated in standard
- Over Limit = Reading in reference to limit
- P = Peak Reading
- Q = Quasi-peak Reading
- A = Average Reading

Calculation Formula

Over Limit (dB) = Level (dBuV) – Limit (dBuV)



7.2.6. TEST RESULTS

Model No.	APC-9172	6dB Bandwidth	10 KHz
Environmental Conditions	25deg.C, 55% RH, 1010 hPa	Test Mode	Mode 2
Tested by	James Hsieh		

(The chart below shows the highest readings taken from the final data.)

Six Highest Conducted Emission Readings						
Frequency Range Investigated				150 KHz to 30 MHz		
Freq (MHz)	Read Level (dBUV)	Factor (dB)	Level (dBUV)	Limit Line (dBUV)	Over Limit (dB)	Reading Type (P/Q/A)
0.658	33.58	9.84	43.42	87.00	-43.58	P
0.720	37.10	9.84	46.94	87.00	-40.06	P
0.775	34.10	9.84	43.94	87.00	-43.06	P
13.479	38.43	10.00	48.43	87.00	-38.57	P
20.270	39.48	10.04	49.52	87.00	-37.48	P
27.271	38.05	10.12	48.17	87.00	-38.83	P

NOTE: 1. The emission level was or more than 2dB below the Average limit, so no re-check anymore.



7.3. RADIATED EMISSION MEASUREMENT

7.3.1. LIMITS

FREQUENCY (MHz)	dBuV/m (At 10m)	
	Class A	Class B
30 ~ 230	40	30
230 ~ 1000	47	37

*NOTE: (1) The lower limit shall apply at the transition frequencies.
 (2) Emission level (dBuV/m) = 20 log Emission level (uV/m).*

7.3.2. TEST INSTRUMENTS

Open Area Test Site # I				
Name of Equipment	Manufacturer	Model	Serial Number	Calibration Due
SITE NSA	CCS	I Site	N/A	10/13/2007
MEASURE RECEIVER	SCHAFFNER	SCR3501	338	07/02/2007
SPECTRUM ANALYZER	ADVANTEST	R3132	120900008	No Calibration Required
ANTENNA	SCHAFFNER	CBL 6112B	2809	09/22/2007
AMPLIFIER	SCHAFFNER	CPA9231A	3626	10/10/2007
CABLE	BELDEN	9913	N-TYPE #12	02/25/2008
ATTENUATOR	MCL	UNAT-6	AT06-3	10/10/2007
THERMO-HYGRO METER	TFA	N/A	NO.2	10/26/2007
DECOUPLING NETWORK	FCC	F-201-DCN-5-6MM	22, 24	08/29/2007
Test S/W	LAB VIEW 7.1			

*NOTE: 1. The calibration interval of the above test instruments is 12 months and the calibrations are traceable to NML/ROC and NIST/USA.
 2. N.C.R = No Calibration Request.*



7.3.3. TEST PROCEDURE (please refer to measurement standard or CCS SOP PA-031)

Procedure of Preliminary Test

- The equipment was set up as per the test configuration to simulate typical usage per the user's manual. When the EUT is a tabletop system, a wooden turntable with a height of 0.8 meters is used which is placed on the ground plane. When the EUT is a floor standing equipment, it is placed on the ground plane which has a 3-12 mm non-conductive covering to insulate the EUT from the ground plane.
- Support equipment, if needed, was placed as per EN 55022.
- All I/O cables were positioned to simulate typical usage as per EN 55022.
- The EUT received AC power source from the outlet socket under the turntable. All support equipment power received from another socket under the turntable.
- Mains cables, telephone lines or other connections to auxiliary equipment located outside the test are shall drape to the floor, be fitted with ferrite clamps or ferrite tubes placed on the floor at the point where the cable reaches the floor and then routed to the place where they leave the turntable. No. extension cords shall be used to mains receptacle.
- The antenna was placed at 10 meter away from the EUT as stated in EN 55022. The antenna connected to the Spectrum Analyzer via a cable and at times a pre-amplifier would be used.
- The Analyzer / Receiver quickly scanned from 30MHz to 1000MHz. The EUT test program was started. Emissions were scanned and measured rotating the EUT to 360 degrees and positioning the antenna 1 to 4 meters above the ground plane, in both the vertical and the horizontal polarization, to maximize the emission reading level.
- The test mode(s) described in Item 3.1 were scanned during the preliminary test:
- After the preliminary scan, we found the test mode described in Item 3.1 producing the highest emission level.
- The EUT and cable configuration, antenna position, polarization and turntable position of the above highest emission level were recorded for the final test.



Procedure of Final Test

- EUT and support equipment were set up on the turntable as per the configuration with highest emission level in the preliminary test.
- The Analyzer / Receiver scanned from 30MHz to 1000MHz. Emissions were scanned and measured rotating the EUT to 360 degrees, varying cable placement and positioning the antenna 1 to 4 meters above the ground plane, in both the vertical and the horizontal polarization, to maximize the emission reading level.
- Recorded at least the six highest emissions. Emission frequency, amplitude, antenna position, polarization and turntable position were recorded into a computer in which correction factors were used to calculate the emission level and compare reading to the applicable limit and only Q.P. reading is presented.
- The test data of the worst-case condition(s) was recorded.

7.3.4. TEST SETUP

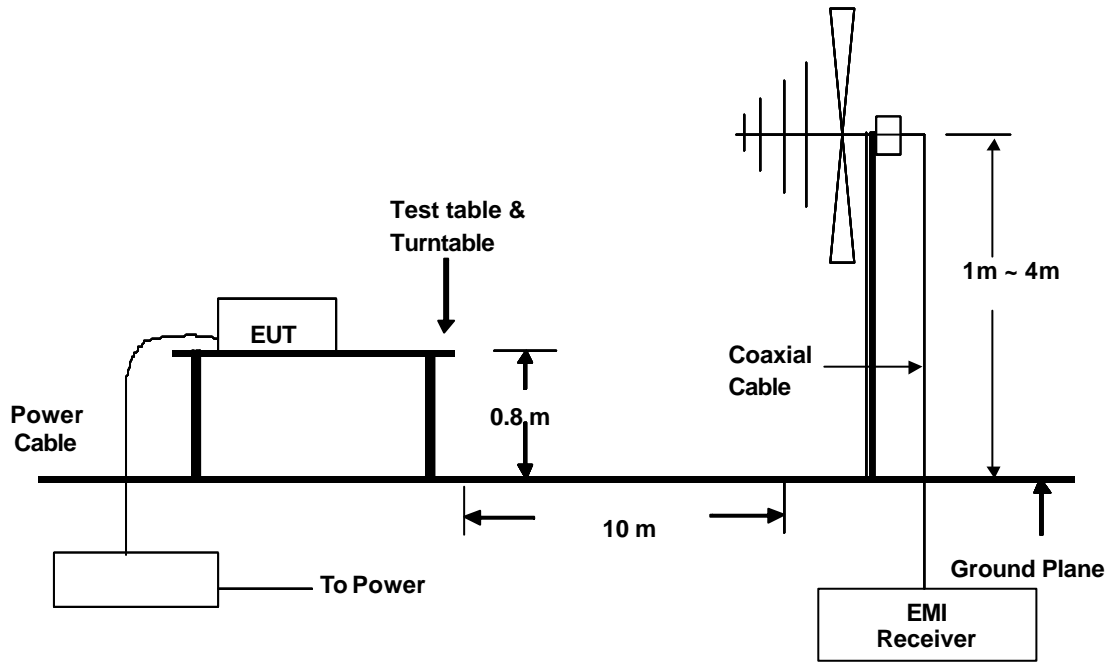

- For the actual test configuration, please refer to the related item – Photographs of the Test Configuration.

7.3.5. DATA SAMPLE

Freq. MHz	Read Level dBuV	Factor dB/m	Level dBuV/m	Limit dBuV/m	Over Limit dB	Reading Type (P/Q/A)	Pol. (H/V)
x.xx	14.0	12.2	26.2	40	-13.8	Q	H

- Freq. = Emission frequency in MHz
- Read Level = Uncorrected Analyzer/Receiver reading
- Factor = Antenna Factor + Cable Loss + Attenuator (3/6/10dB) – Amplifier Gain
- Level = Read Level + Factor
- Limit = Limit stated in standard
- Over Limit = Reading in reference to limit
- P = Peak Reading
- Q = Quasi-peak Reading
- A = Average Reading
- H = Antenna Polarization: Horizontal
- V = Antenna Polarization: Vertical

Calculation Formula

Over Limit (dB) = Level (dBuV/m) – Limit (dBuV/m)



7.3.6. TEST RESULTS

Model No.	APC-9172	Test Mode	Mode 1
Environmental Conditions	25deg.C, 701% RH, 1008 hPa	6dB Bandwidth	120 KHz
Antenna Pole	Vertical	Antenna Distance	10m
Detector Function	Quasi-peak.	Tested by	Alex Pan

(The chart below shows the highest readings taken from the final data.)

Six Highest Radiated Emission Readings							
Frequency Range Investigated				30 MHz to 1000 MHz at 10m			
Freq (MHz)	Read Level (dBuV)	Factor (dB/m)	Level (dBuV/m)	Limit Line (dBuV/m)	Over Limit (dB)	Reading Type (P/Q/A)	Pol. (H/V)
72.010	42.10	-14.02	28.08	40.00	-11.92	Q	V
166.673	44.80	-9.73	35.07	40.00	-4.93	Q	V
215.997	42.00	-9.53	32.47	40.00	-7.53	Q	V
239.999	44.80	-7.55	37.25	47.00	-9.75	Q	V
300.016	38.20	-4.45	33.75	47.00	-13.25	Q	V
600.170	33.50	3.67	37.17	47.00	-9.83	Q	V

REMARKS: 1. P= Peak Reading; Q= Quasi-peak Reading A= Average Reading
2. The other emission levels were very low against the limit.



Model No.	APC-9172	Test Mode	Mode 1
Environmental Conditions	25deg.C, 701% RH, 1008 hPa	6dB Bandwidth	120 KHz
Antenna Pole	Horizontal	Antenna Distance	10m
Detector Function	Quasi-peak.	Tested by	Alex Pan

(The chart below shows the highest readings taken from the final data.)

Six Highest Radiated Emission Readings							
Frequency Range Investigated				30 MHz to 1000 MHz at 10m			
Freq (MHz)	Read Level (dBuV)	Factor (dB/m)	Level (dBuV/m)	Limit Line (dBuV/m)	Over Limit (dB)	Reading Type (P/Q/A)	Pol. (H/V)
73.070	44.20	-13.98	30.22	40.00	-9.78	Q	H
166.685	44.20	-9.73	34.47	40.00	-5.53	Q	H
214.960	43.20	-9.61	33.59	40.00	-6.41	Q	H
239.992	40.50	-7.55	32.95	47.00	-14.05	Q	H
300.022	38.20	-4.45	33.75	47.00	-13.25	Q	H
600.020	32.50	3.67	36.17	47.00	-10.83	Q	H

REMARKS: 1. P= Peak Reading; Q= Quasi-peak Reading A= Average Reading
 2. The other emission levels were very low against the limit.



7.4. HARMONICS CURRENT MEASUREMENT

7.4.1. LIMITS OF HARMONICS CURRENT MEASUREMENT

Limits for Class A equipment		Limits for Class D equipment		
Harmonics Order n	Max. permissible harmonics current A	Harmonics Order n	Max. permissible harmonics current per watt mA/W	Max. permissible harmonics current A
Odd harmonics		Odd Harmonics only		
3	2.30	3	3.4	2.30
5	1.14	5	1.9	1.14
7	0.77	7	1.0	0.77
9	0.40	9	0.5	0.40
11	0.33	11	0.35	0.33
13	0.21	13	0.30	0.21
15<=n<=39	0.15x15/n	15<=n<=39	3.85/n	0.15x15/n
Even harmonics				
2	1.08			
4	0.43			
6	0.30			
8<=n<=40	0.23x8/n			

NOTE: 1. Class A and Class D are classified according to item 4.4.3.
 2. According to section 7 of EN 61000-3-2, the above limits for all equipment except for lighting equipment having an active input power > 75 W and no limits apply for equipment with an active input power up to and including 75 W.

7.4.2. TEST INSTRUMENTS

Name of Equipment	Manufacturer	Model	Serial Number	Calibration Due
Signal Conditioning Unit	Schaffner	CCN 1000-1	72122	11/23/2007
5KVA AC Power Source	Schaffner	NSG 1007	55131	No Calibration Required
Software	Win2100V3.exe			

NOTE: 1. The calibration interval of the above test instruments is 12 months and the calibrations are traceable to NML/ROC and NIST/USA.



7.4.3. TEST PROCEDURE (please refer to measurement standard or CCS SOP PA-029)

- The EUT was placed on the top of a wooden table 0.8 meters above the ground and operated to produce the maximum harmonic components under normal operating conditions for each successive harmonic component in turn.
- The classification of EUT is according to section 5 of EN 61000-3-2.
- The EUT is classified as follows:
 - Class A: Balanced three-phase equipment, Household appliances excluding equipment as Class D, Tools excluding portable tools, Dimmers for incandescent lamps, audio equipment, equipment not specified in one of the three other classes.
 - Class B: Portable tools; Arc welding equipment which is not professional equipment.
 - Class C: Lighting equipment.
 - Class D: Equipment having a specified power less than or equal to 600 W of the following types:
Personal computers and personal computer monitors and television receivers.
- The correspondent test program of test instrument to measure the current harmonics emanated from EUT is chosen. The measure time shall be not less than the time necessary for the EUT to be exercised.

7.4.4. TEST SETUP

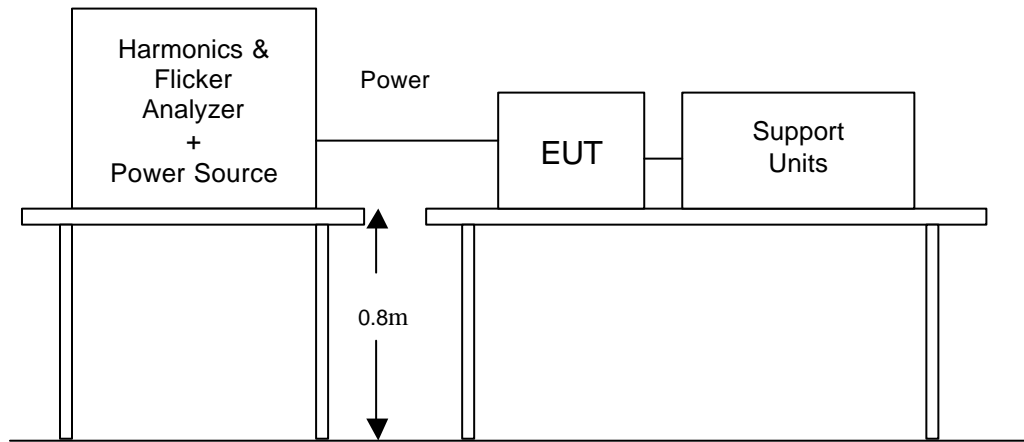

- For the actual test configuration, please refer to the related item – Photographs of the Test Configuration.

7.4.5. TEST RESULTS

Power Consumption	71.3W	Test Results	PASS
Environmental Conditions	19°C, 59% RH, 1009mbar	Limits	Class <input type="checkbox"/> A <input type="checkbox"/> B <input type="checkbox"/> C <input checked="" type="checkbox"/> D
Test Mode	Operating	Tested by:	John Yen

*NOTE: 1. Limits classified according to item 7.4.3.
 2. The EUT power level is below 75.0 Watts and therefore has no defined limits.*



TEST RESULT OF EN 61000-3-2

Test Result: Pass

Source qualification: Normal

Current & voltage waveforms

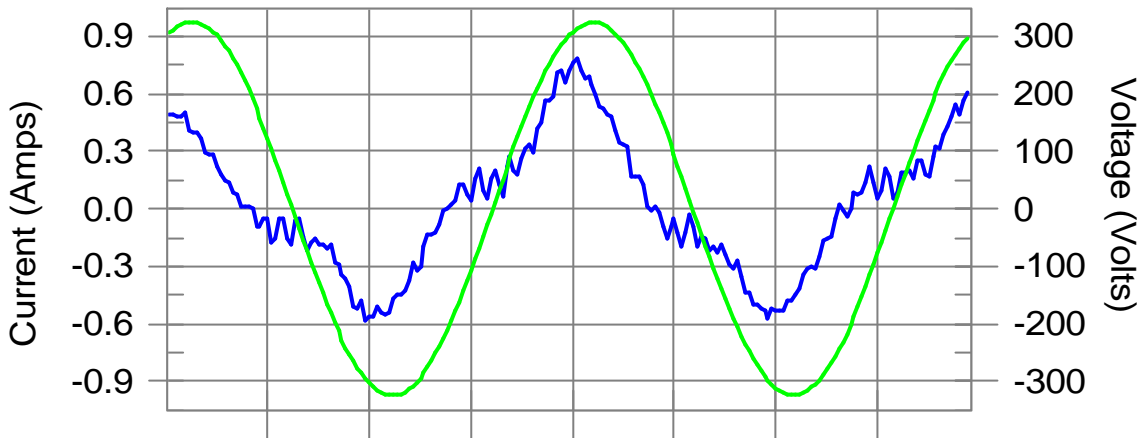

Harmonics and Class D limit line

European Limits

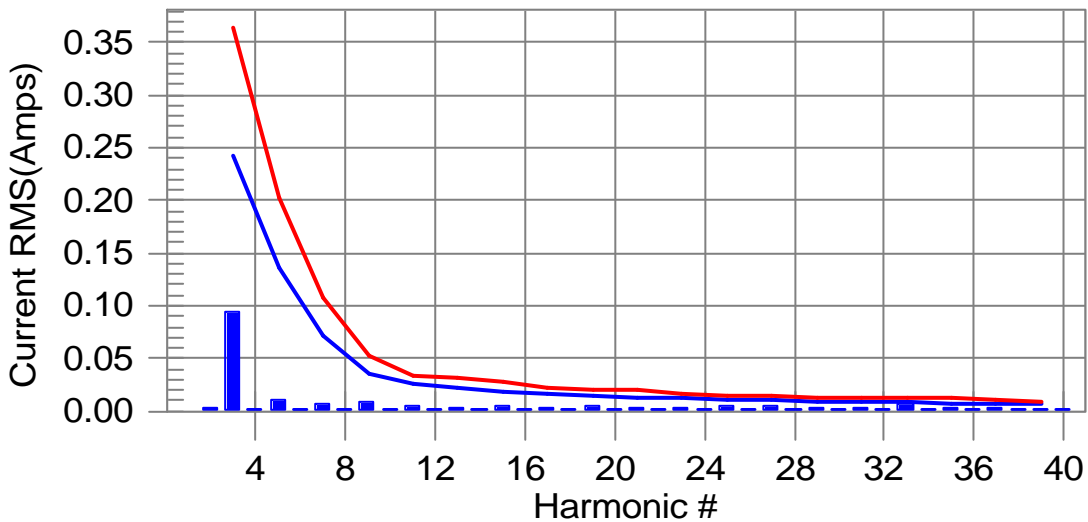

Test result: Pass Worst harmonic was #0 with 0.00% of the limit.



Test Result: Pass

Source qualification: Normal

THC(A): 0.00

FTHD(%): 0.00

POHC(A): 0.000

POHC Limit(A): 0.000

Highest parameter values during test:

V_RMS (Volts): 230.03

Frequency(Hz): 50.00

I_Peak (Amps): 0.804

I_RMS (Amps): 0.357

I_Fund (Amps): 0.322

Crest Factor: 2.406

Power (Watts): 71.3

Power Factor: 0.870

Harm#	Harms(avg)	100%Limit	%of Limit	Harms(max)	150%Limit	%of Limit	Status
2	0.002						
3	0.089	0.242	0.0	0.094	0.363	0.00	Pass
4	0.001						
5	0.011	0.135	0.0	0.011	0.203	0.00	Pass
6	0.001						
7	0.006	0.071	0.0	0.007	0.107	0.00	Pass
8	0.000						
9	0.008	0.036	0.0	0.009	0.053	0.00	Pass
10	0.001						
11	0.005	0.025	0.0	0.006	0.034	0.00	Pass
12	0.001						
13	0.003	0.021	0.0	0.004	0.032	0.00	Pass
14	0.001						
15	0.003	0.019	0.0	0.004	0.027	0.00	Pass
16	0.001						
17	0.003	0.016	0.0	0.004	0.022	0.00	Pass
18	0.001						
19	0.004	0.014	0.0	0.004	0.020	0.00	Pass
20	0.001						
21	0.002	0.013	0.0	0.002	0.020	0.00	Pass
22	0.001						
23	0.003	0.012	0.0	0.004	0.016	0.00	Pass
24	0.001						
25	0.004	0.011	0.0	0.005	0.015	0.00	Pass
26	0.001						
27	0.005	0.010	0.0	0.005	0.015	0.00	Pass
28	0.001						
29	0.003	0.009	0.0	0.003	0.013	0.00	Pass
30	0.002						
31	0.003	0.009	0.0	0.004	0.012	0.00	Pass
32	0.001						
33	0.006	0.008	0.0	0.007	0.012	0.00	Pass
34	0.001						
35	0.003	0.008	0.0	0.004	0.012	0.00	Pass
36	0.001						
37	0.002	0.007	0.0	0.003	0.010	0.00	Pass
38	0.001						
39	0.002	0.007	0.0	0.002	0.010	0.00	Pass
40	0.001						

Note: The EUT power level is below 75.0 Watts and therefore has no defined limits



Test Result: Pass

Source qualification: Normal

Highest parameter values during test:

Voltage (Vrms):	230.03	Frequency(Hz):	50.00
I_Peak (Amps):	0.804	I_RMS (Amps):	0.357
I_Fund (Amps):	0.322	Crest Factor:	2.406
Power (Watts):	71.3	Power Factor:	0.870

Harm#	Harmonics V-rms	Limit V-rms	% of Limit	Status
2	0.254	0.460	55.16	OK
3	0.452	2.067	21.89	OK
4	0.085	0.460	18.43	OK
5	0.061	0.918	6.63	OK
6	0.085	0.460	18.56	OK
7	0.060	0.689	8.72	OK
8	0.051	0.459	11.01	OK
9	0.069	0.460	14.94	OK
10	0.039	0.460	8.39	OK
11	0.051	0.230	22.04	OK
12	0.034	0.230	14.92	OK
13	0.045	0.230	19.62	OK
14	0.032	0.230	13.94	OK
15	0.031	0.230	13.33	OK
16	0.031	0.230	13.54	OK
17	0.029	0.230	12.58	OK
18	0.043	0.230	18.70	OK
19	0.034	0.230	14.93	OK
20	0.027	0.230	11.76	OK
21	0.033	0.230	14.30	OK
22	0.022	0.230	9.63	OK
23	0.038	0.230	16.72	OK
24	0.017	0.230	7.35	OK
25	0.025	0.230	10.87	OK
26	0.019	0.230	8.41	OK
27	0.034	0.230	14.68	OK
28	0.021	0.230	9.09	OK
29	0.023	0.230	10.04	OK
30	0.059	0.230	25.75	OK
31	0.027	0.230	11.68	OK
32	0.015	0.230	6.69	OK
33	0.026	0.230	11.21	OK
34	0.011	0.230	4.65	OK
35	0.016	0.230	6.83	OK
36	0.010	0.230	4.29	OK
37	0.013	0.230	5.69	OK
38	0.009	0.230	3.97	OK
39	0.011	0.230	4.90	OK
40	0.013	0.230	5.69	OK



7.5. VOLTAGE FLUCTUATION AND FLICKER MEASUREMENT

7.5.1. LIMITS OF VOLTAGE FLUCTUATION AND FLICKER MEASUREMENT

TEST ITEM	LIMIT	REMARK
P _{st}	1.0	P _{st} means short-term flicker indicator.
P _{lt}	0.65	P _{lt} means long-term flicker indicator.
T _{dt} (ms)	500	T _{dt} means maximum time that dt exceeds 3 %.
d _{max} (%)	4%	d _{max} means maximum relative voltage change.
dc (%)	3.3%	dc means relative steady-state voltage change

7.5.2. TEST INSTRUMENTS

IMMUNITY SHIELDED ROOM				
Name of Equipment	Manufacturer	Model	Serial Number	Calibration Due
Signal Conditioning Unit	Schaffner	CCN 1000-1	72122	11/23/2007
5KVA AC Power Source	Schaffner	NSG 1007	55131	No Calibration Required
Software	Win2100V3.exe			

NOTE: The calibration interval of the above test instruments is 12 months and the calibrations are traceable to NML/ROC and NIST/USA.

7.5.3. TEST PROCEDURE (please refer to measurement standard or CCS SOP PA-030)

- The EUT was placed on the top of a wooden table 0.8 meters above the ground and operated to produce the most unfavorable sequence of voltage changes under normal operating conditions.
- During the flick measurement, the measure time shall include that part of whole operation cycle in which the EUT produce the most unfavorable sequence of voltage changes. The observation period for short-term flicker indicator is 10 minutes and the observation period for long-term flicker indicator is 2 hours.

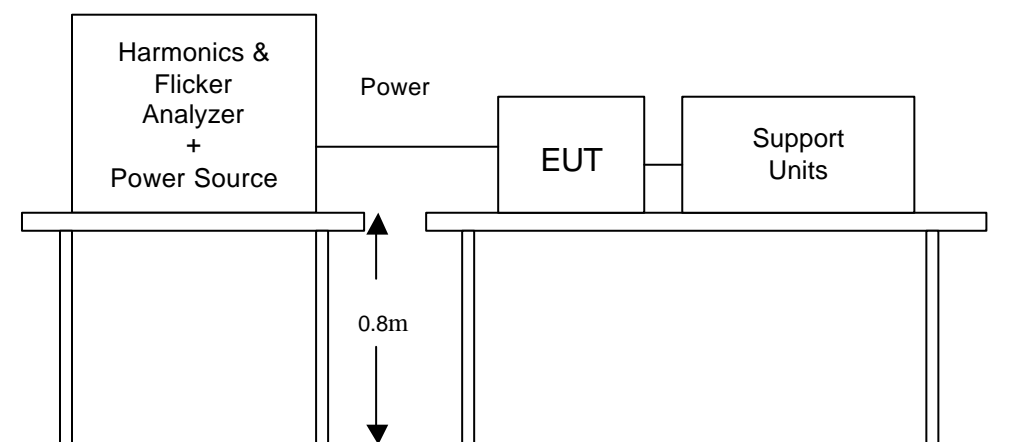
7.5.4. TEST SETUP

- For the actual test configuration, please refer to the related item – Photographs of the Test Configuration.



7.5.5. TEST RESULTS

Observation Period (Tp)	30mins	Test Mode	Operating
Environmental Conditions	18°C, 58% RH, 1008mbar	Tested by	John Yen

TEST PARAMETER	MEASUREMENT VALUE	LIMIT	REMARK
P _{st}	0.297	1.0	Pass
P _{lt}	0.166	0.65	Pass
T _{dt} (ms)	0	500	Pass
d _{max} (%)	0	4%	Pass
dc (%)	0	3.3%	Pass

Note: None.



Test result of en 61000-3-3

Test Result: Pass

Status: Test Completed

Pst_i and limit line

European Limits

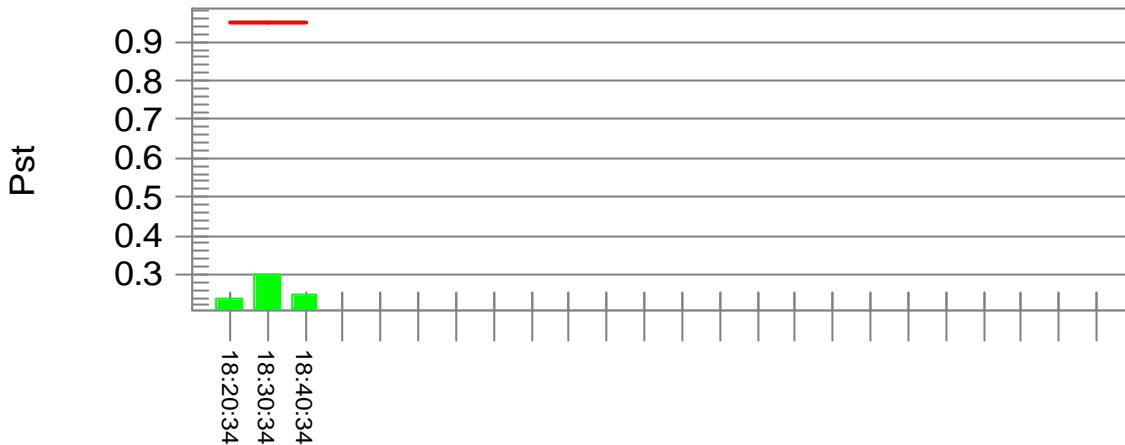

Plt and limit line

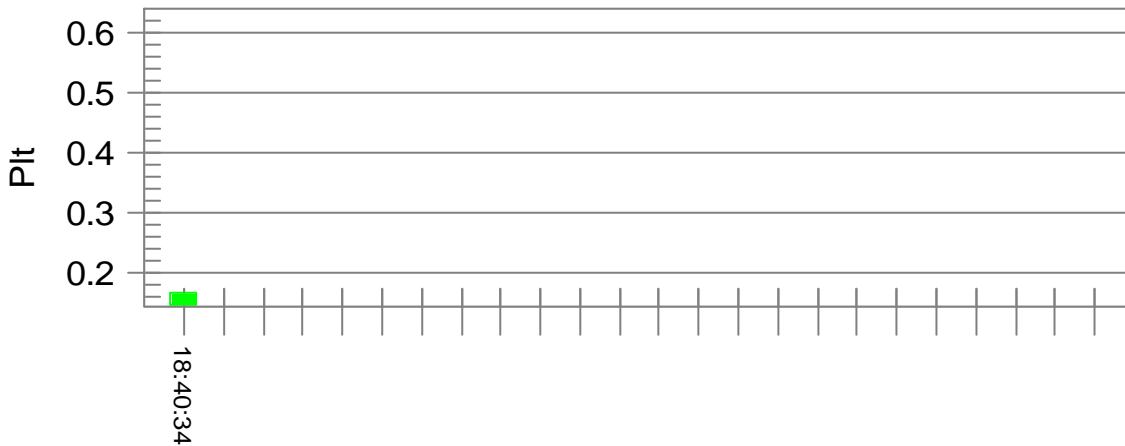

Parameter values recorded during the test:

Vrms at the end of test (Volt):	229.64		
Highest dt (%):	0.00	Test limit (%):	3.14 Pass
Time(mS) > dt:	0.0	Test limit (mS):	500.0 Pass
Highest dc (%):	0.00	Test limit (%):	3.14 Pass
Highest dmax (%):	0.00	Test limit (%):	3.80 Pass
Highest Pst (10 min. period):	0.297	Test limit:	0.950 Pass
Highest Plt (2 hr. period):	0.166	Test limit:	0.617 Pass

8 IMMUNITY TEST

8.1. GENERAL DESCRIPTION

Product Standard	EN 55024: 1998 + A1: 2001 + A2: 2003	
	Test Type	Minimum Requirement
Basic Standard, Specification, and Performance Criterion required	IEC 61000-4-2	Electrostatic Discharge – ESD: 8KV air discharge, 4KV Contact discharge, Performance Criterion B
	IEC 61000-4-3	Radio-Frequency Electromagnetic Field Susceptibility Test – RS: 80 ~1000 MHz, 3V/m, 80% AM(1kHz), Performance Criterion A
	IEC 61000-4-4	Electrical Fast Transient/Burst - EFT, Power line: 1KV, Signal line: 0.5KV, Performance Criterion B
	IEC 61000-4-5	Surge Immunity Test: 1.2/50 us Open Circuit Voltage, 8 /20 us Short Circuit Current, Power Port ~ Line to line: 1KV, Line to ground: 2KV Signal Port ~ Lines to ground :0.5KV Performance Criterion B
	IEC 61000-4-6	Conducted Radio Frequency Disturbances Test – CS: 0.15 ~ 80 MHz, 3Vrms, 80% AM, 1kHz, Performance Criterion A
	IEC 61000-4-8	Power frequency magnetic field immunity test 50 Hz, 1A/m Performance Criterion A
	IEC 61000-4-11	Voltage Dips: i) >95% reduction for 0.5 period, Performance Criterion B ii) 30% reduction for 25 period, Performance Criterion C Voltage Interruptions: >95% reduction for 250 period Performance Criterion C



8.2. GENERAL PERFORMANCE CRITERIA DESCRIPTION

Criteria A:	The apparatus shell continues to operate as intended without operator intervention. No degradation of performance or loss of function is allowed below a performance level specified by the manufacturer, when the apparatus is used as intended. The performance level may be replaced by a permissible loss of performance. If the manufacturer does not specify the minimum performance level or the permissible performance loss, then either of these may be derived from the product description and documentation, and by what the user may reasonably expect from the equipment if used as intended.
Criteria B:	After test, the apparatus shell continues to operate as intended without operator intervention. No degradation of performance or loss of function is allowed, after the application of the phenomenon below a performance level specified by the manufacturer, when the apparatus is used as intended. The performance level may be replaced by a permissible loss of performance. During the test, degradation of performance is however allowed. However, no change of operating state if stored data is allowed to persist after the test. If the manufacturer does not specify the minimum performance level or the permissible performance loss, then either of these may be derived from the product description and documentation, and by what the user may reasonably expect from the equipment if used as intended.
Criteria C:	Temporary loss of function is allowed, provided the functions is self-recoverable or can be restored by the operation of controls by the user in accordance with the manufacturer instructions. Functions, and/or information stored in non-volatile memory, or protected by a battery backup, shall not be lost.



8.3. ELECTROSTATIC DISCHARGE (ESD)

8.3.1. TEST SPECIFICATION

Basic Standard: EN 61000-4-2

Discharge Impedance: 330 ohm / 150 pF

Discharge Voltage: Air Discharge: 2 ; 4 ; 8 KV (Direct)
Contact Discharge: 2 ; 4 KV (Direct/Indirect)

Polarity: Positive & Negative

Number of Discharge: Minimum 10 times at each test point

Discharge Mode: Single Discharge
1 second minimum

8.3.2. TEST INSTRUMENT

Table with 5 columns: Name of Equipment, Manufacturer, Model, Serial Number, Calibration Due. Rows include ESD Simulator, Aneroid Barometer, and Thermo-Hygro meter.

NOTE: The calibration interval of the above test instruments is 12 months and the calibrations are traceable to NML/ROC and NIST/USA.

8.3.3. TEST PROCEDURE (please refer to measurement standard or CCS SOP PA-022)

The discharges shall be applied in two ways:

a) Contact discharges to the conductive surfaces and coupling planes:

The EUT shall be exposed to at least 200 discharges, 100 each at negative and positive polarity, at a minimum of four test points. One of the test points shall be subjected to at least 50 indirect discharges to the center of the front edge of the **Horizontal Coupling Plane (HCP)**. The remaining three test points shall each receive at least 50 direct contact discharges. If no direct contact test points are available, then at least 200 indirect discharges shall be applied in the indirect mode. Test shall be performed at a maximum repetition rate of one discharge per second.

b) Air discharges at slots and apertures and insulating surfaces:

On those parts of the EUT where it is not possible to perform contact discharge testing, the equipment should be investigated to identify user accessible points where breakdown may occur. Such points are tested using the air discharge method. This investigation should be restricted to those area normally handled by the user. A minimum of 10 single air discharges shall be applied to the selected test point for each such area.

The basic test procedure was in accordance with IEC 61000-4-2:

- a) The EUT was located 0.1 m minimum from all side of the **HCP** (dimensions 1.6m x 0.8m).
- b) The support units were located another table 30 cm away from the EUT, but direct support unit was/were located at same location as EUT on the HCP and keep at a distance of 10 cm with EUT.
- c) The time interval between two successive single discharges was at least 1 second.
- d) Contact discharges were applied to the non-insulating coating, with the pointed tip of the generator penetrating the coating and contacting the conducting substrate.
- e) Air discharges were applied with the round discharge tip of the discharge electrode approaching the EUT as fast as possible (without causing mechanical damage) to touch the EUT. After each discharge, the ESD generator was removed from the EUT and re-triggered for a new single discharge. The test was repeated until all discharges were complete.
- f) At least ten single discharges (in the most sensitive polarity) were applied at the front edge of each **HCP** opposite the center point of each unit of the EUT and 0.1 meters from the front of the EUT. The long axis of the discharge electrode was in the plane of the **HCP** and perpendicular to its front edge during the discharge.
- g) At least ten single discharges (in the most sensitive polarity) were applied to the center of one vertical edge of the **Vertical Coupling Plane (VCP)** in sufficiently different positions that the four faces of the EUT were completely illuminated. The **VCP** (dimensions 0.5m x 0.5m) was placed vertically to and 0.1 meters from the EUT.

8.3.4. TEST SETUP

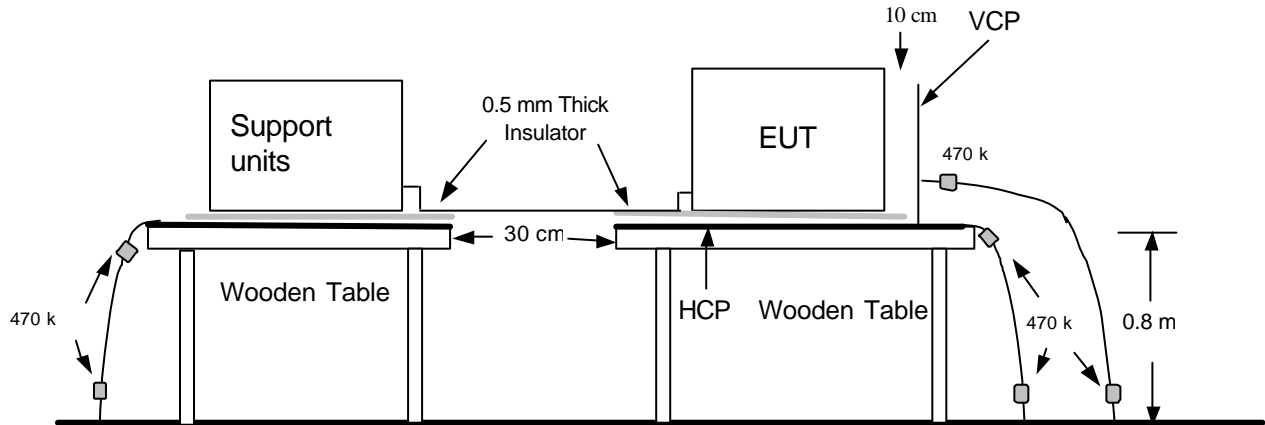

Ground Reference Plane

- For the actual test configuration, please refer to the related item – Photographs of the Test Configuration.

NOTE:

TABLE-TOP EQUIPMENT

The configuration consisted of a wooden table 0.8 meters high standing on the **Ground Reference Plane**. The **GRP** consisted of a sheet of aluminum at least 0.25mm thick, and 2.5 meters square connected to the protective grounding system. A **Horizontal Coupling Plane** (1.6m x 0.8m) was placed on the table and attached to the **GRP** by means of a cable with 940k total impedance. The equipment under test, was installed in a representative system as described in section 7 of EN 61000-4-2, and its cables were placed on the **HCP** and isolated by an insulating support of 0.5mm thickness. A distance of 1-meter minimum was provided between the EUT and the walls of the laboratory and any other metallic structure.

FLOOR-STANDING EQUIPMENT

The equipment under test was installed in a representative system as described in section 7 of IEC 61000-4-2, and its cables were isolated from the Ground Reference Plane by an insulating support of 0.1-meter thickness. The GRP consisted of a sheet of aluminum that is at least 0.25mm thick, and 2.5 meters square connected to the protective grounding system and extended at least 0.5 meters from the EUT on all sides.



8.3.5. TEST RESULTS

Temperature	18°C	Humidity	58% RH
Pressure	1008mbar	Tested By	John Yen
Required Passing Performance		Criterion B	

Air Discharge										
Test Points	Test Levels			Results						
	± 2 KV	± 4 KV	± 8 KV	Pass	Fail	Performance Criterion		Observation		
Front	<input checked="" type="checkbox"/>	<input checked="" type="checkbox"/>	<input checked="" type="checkbox"/>	<input checked="" type="checkbox"/>	<input type="checkbox"/>	<input checked="" type="checkbox"/> A	<input type="checkbox"/> B	Note	<input checked="" type="checkbox"/> 1	<input type="checkbox"/> 2
Back	<input checked="" type="checkbox"/>	<input checked="" type="checkbox"/>	<input checked="" type="checkbox"/>	<input checked="" type="checkbox"/>	<input type="checkbox"/>	<input checked="" type="checkbox"/> A	<input type="checkbox"/> B	Note	<input checked="" type="checkbox"/> 1	<input type="checkbox"/> 2
Left	<input checked="" type="checkbox"/>	<input checked="" type="checkbox"/>	<input checked="" type="checkbox"/>	<input checked="" type="checkbox"/>	<input type="checkbox"/>	<input checked="" type="checkbox"/> A	<input type="checkbox"/> B	Note	<input checked="" type="checkbox"/> 1	<input type="checkbox"/> 2
Right	<input checked="" type="checkbox"/>	<input checked="" type="checkbox"/>	<input checked="" type="checkbox"/>	<input checked="" type="checkbox"/>	<input type="checkbox"/>	<input checked="" type="checkbox"/> A	<input type="checkbox"/> B	Note	<input checked="" type="checkbox"/> 1	<input type="checkbox"/> 2
Top	<input checked="" type="checkbox"/>	<input checked="" type="checkbox"/>	<input checked="" type="checkbox"/>	<input checked="" type="checkbox"/>	<input type="checkbox"/>	<input checked="" type="checkbox"/> A	<input type="checkbox"/> B	Note	<input checked="" type="checkbox"/> 1	<input type="checkbox"/> 2
Bottom	<input checked="" type="checkbox"/>	<input checked="" type="checkbox"/>	<input checked="" type="checkbox"/>	<input checked="" type="checkbox"/>	<input type="checkbox"/>	<input checked="" type="checkbox"/> A	<input type="checkbox"/> B	Note	<input checked="" type="checkbox"/> 1	<input type="checkbox"/> 2

Contact Discharge										
Test Points	Test Levels			Results						
	± 2 KV	± 4 KV	± 8 KV	Pass	Fail	Performance Criterion		Observation		
Front	<input checked="" type="checkbox"/>	<input checked="" type="checkbox"/>	<input type="checkbox"/>	<input checked="" type="checkbox"/>	<input type="checkbox"/>	<input checked="" type="checkbox"/> A	<input type="checkbox"/> B	Note	<input checked="" type="checkbox"/> 1	<input type="checkbox"/> 2
Back	<input checked="" type="checkbox"/>	<input checked="" type="checkbox"/>	<input type="checkbox"/>	<input checked="" type="checkbox"/>	<input type="checkbox"/>	<input checked="" type="checkbox"/> A	<input type="checkbox"/> B	Note	<input checked="" type="checkbox"/> 1	<input type="checkbox"/> 2
Left	<input checked="" type="checkbox"/>	<input checked="" type="checkbox"/>	<input type="checkbox"/>	<input checked="" type="checkbox"/>	<input type="checkbox"/>	<input checked="" type="checkbox"/> A	<input type="checkbox"/> B	Note	<input checked="" type="checkbox"/> 1	<input type="checkbox"/> 2
Right	<input checked="" type="checkbox"/>	<input checked="" type="checkbox"/>	<input type="checkbox"/>	<input checked="" type="checkbox"/>	<input type="checkbox"/>	<input checked="" type="checkbox"/> A	<input type="checkbox"/> B	Note	<input checked="" type="checkbox"/> 1	<input type="checkbox"/> 2
Top	<input checked="" type="checkbox"/>	<input checked="" type="checkbox"/>	<input type="checkbox"/>	<input checked="" type="checkbox"/>	<input type="checkbox"/>	<input checked="" type="checkbox"/> A	<input type="checkbox"/> B	Note	<input checked="" type="checkbox"/> 1	<input type="checkbox"/> 2
Bottom	<input checked="" type="checkbox"/>	<input checked="" type="checkbox"/>	<input type="checkbox"/>	<input checked="" type="checkbox"/>	<input type="checkbox"/>	<input checked="" type="checkbox"/> A	<input type="checkbox"/> B	Note	<input checked="" type="checkbox"/> 1	<input type="checkbox"/> 2

Please refer to ESD test photo on next page for detail discharge point

Discharge To Horizontal Coupling Plane										
Side of EUT	Test Levels			Results						
	± 2 KV	± 4 KV	± 8 KV	Pass	Fail	Performance Criterion		Observation		
Front	<input checked="" type="checkbox"/>	<input checked="" type="checkbox"/>	<input type="checkbox"/>	<input checked="" type="checkbox"/>	<input type="checkbox"/>	<input checked="" type="checkbox"/> A	<input type="checkbox"/> B	Note	<input checked="" type="checkbox"/> 1	<input type="checkbox"/> 2
Back	<input checked="" type="checkbox"/>	<input checked="" type="checkbox"/>	<input type="checkbox"/>	<input checked="" type="checkbox"/>	<input type="checkbox"/>	<input checked="" type="checkbox"/> A	<input type="checkbox"/> B	Note	<input checked="" type="checkbox"/> 1	<input type="checkbox"/> 2
Left	<input checked="" type="checkbox"/>	<input checked="" type="checkbox"/>	<input type="checkbox"/>	<input checked="" type="checkbox"/>	<input type="checkbox"/>	<input checked="" type="checkbox"/> A	<input type="checkbox"/> B	Note	<input checked="" type="checkbox"/> 1	<input type="checkbox"/> 2
Right	<input checked="" type="checkbox"/>	<input checked="" type="checkbox"/>	<input type="checkbox"/>	<input checked="" type="checkbox"/>	<input type="checkbox"/>	<input checked="" type="checkbox"/> A	<input type="checkbox"/> B	Note	<input checked="" type="checkbox"/> 1	<input type="checkbox"/> 2

Discharge To Vertical Coupling Plane										
Side of EUT	Test Levels			Results						
	± 2 KV	± 4 KV	± 8 KV	Pass	Fail	Performance Criterion		Observation		
Front	<input checked="" type="checkbox"/>	<input checked="" type="checkbox"/>	<input type="checkbox"/>	<input checked="" type="checkbox"/>	<input type="checkbox"/>	<input checked="" type="checkbox"/> A	<input type="checkbox"/> B	Note	<input checked="" type="checkbox"/> 1	<input type="checkbox"/> 2
Back	<input checked="" type="checkbox"/>	<input checked="" type="checkbox"/>	<input type="checkbox"/>	<input checked="" type="checkbox"/>	<input type="checkbox"/>	<input checked="" type="checkbox"/> A	<input type="checkbox"/> B	Note	<input checked="" type="checkbox"/> 1	<input type="checkbox"/> 2
Left	<input checked="" type="checkbox"/>	<input checked="" type="checkbox"/>	<input type="checkbox"/>	<input checked="" type="checkbox"/>	<input type="checkbox"/>	<input checked="" type="checkbox"/> A	<input type="checkbox"/> B	Note	<input checked="" type="checkbox"/> 1	<input type="checkbox"/> 2
Right	<input checked="" type="checkbox"/>	<input checked="" type="checkbox"/>	<input type="checkbox"/>	<input checked="" type="checkbox"/>	<input type="checkbox"/>	<input checked="" type="checkbox"/> A	<input type="checkbox"/> B	Note	<input checked="" type="checkbox"/> 1	<input type="checkbox"/> 2

NOTE: 1. There was no change compared with initial operation during the test.

The Photo for Discharge Points of EUT



Red Dot —Air Contact Discharged
Blue Dot —Contact Discharged



Red Dot —Air Contact Discharged
Blue Dot —Contact Discharged



Red Dot —Air Contact Discharged
Blue Dot —Contact Discharged



8.4. RADIATED, RADIO-FREQUENCY, ELECTROMAGNETIC FIELD (RS)

8.4.1. TEST SPECIFICATION

Basic Standard: EN 61000-4-3
Frequency Range: 80 MHz ~1000 MHz
Field Strength: 3 V/m
Modulation: 1kHz Sine Wave, 80%, AM Modulation
Frequency Step: 1 % of preceding frequency value
Polarity of Antenna: Horizontal and Vertical
Test Distance: 3 m
Antenna Height: 1.5m

8.4.2. TEST INSTRUMENT

733 RS Chamber				
Name of Equipment	Manufacturer	Model	Serial Number	Calibration Due
Calibration of Field	N/A	Chamber#RS	200604H/V-2	06/23/2007
Signal Generator	Agilent	E4421B	MY43350597	05/17/2007
RF Voltmeter	Boonton	9200B	328001AE	02/04/2008
Function Generator	BNC	625A	25451	02/01/2008
Amplifier	AR	100W1000M1	17564	No Calibration Required
Direction Coupler	AR	DC6180A	312189	No Calibration Required
Broadband Antenna	AR	AT1080	311819	No Calibration Required
Thermo-Hygro meter	TFA	N/A	NO.6	10/26/2007
Software	SW1005 Release 1.4.exe			

NOTE: 1. The calibration interval of the above test instruments is 12 months and the calibrations are traceable to NML/ROC and NIST/USA.
 2. N.C.R. = No Calibration required



8.4.3. TEST PROCEDURE (please refer to measurement standard or CCS SOP PA-023)

The test procedure was in accordance with EN 61000-4-3

- a) The testing was performed in a fully anechoic chamber. The transmit antenna was located at a distance of 3 meters from the EUT.
- b) The frequency range is swept from 80 MHz to 1000 MHz, with the signal 80% amplitude modulated with a 1kHz sine-wave. The rate of sweep did not exceed 1.5×10^{-3} decade/s, where the frequency range is swept incrementally, the step size was 1% of preceding frequency value.
- c) The dwell time at each frequency shall be not less than the time necessary for the EUT to be able to respond.
- e) The test was performed with the EUT exposed to both vertically and horizontally polarized fields on each of the four sides.

8.4.4. TEST SETUP

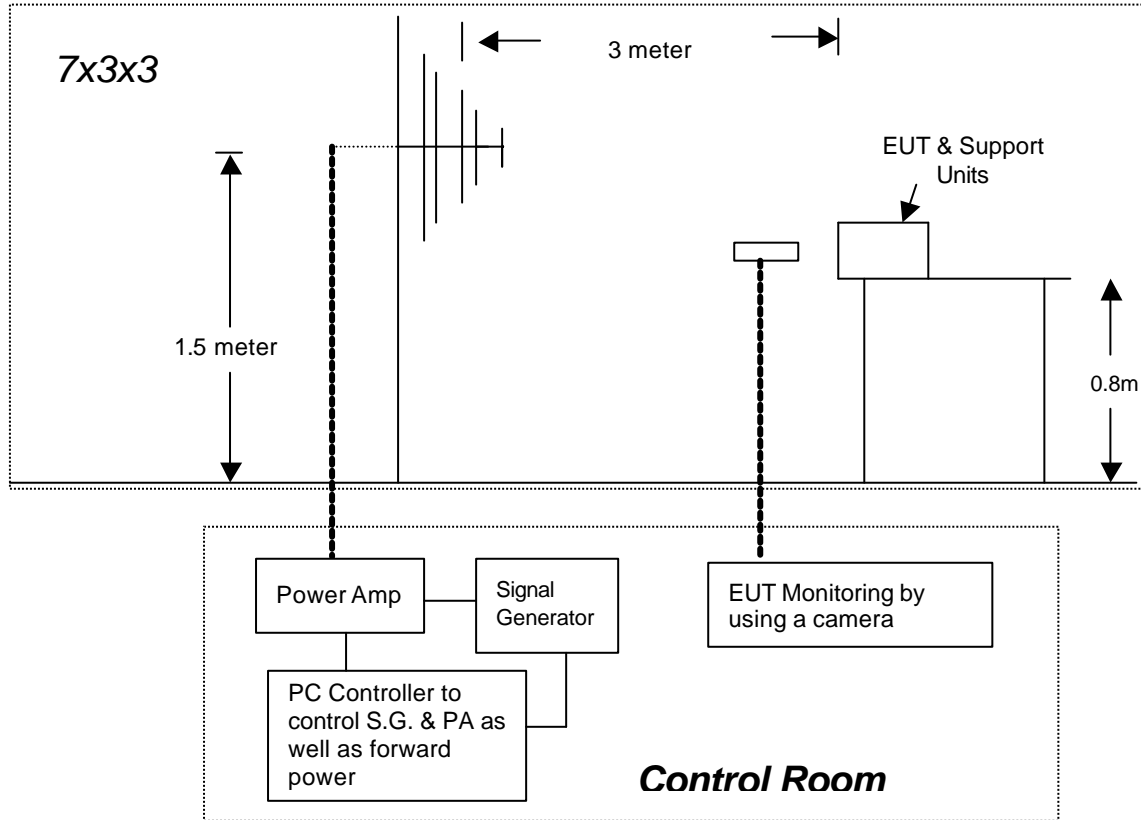

- For the actual test configuration, please refer to the related item – Photographs of the Test Configuration.

NOTE:

TABLETOP EQUIPMENT

The EUT installed in a representative system as described in section 7 of EN 61000-4-3 was placed on a non-conductive table 0.8 meters in height. The system under test was connected to the power and signal wire according to relevant installation instructions.

FLOOR STANDING EQUIPMENT

The EUT installed in a representative system as described in section 7 of IEC 61000-4-3 was placed on a non-conductive wood support 0.1 meters in height. The system under test was connected to the power and signal wire according to relevant installation instructions.



8.4.5. TEST RESULTS

Temperature	19°C	Humidity	59% RH
Pressure	1009mbar	Dwell Time	3 sec.
Tested By	John Yen	Required Passing Performance	Criterion A

Frequency (MHz)	Polarity	Azimuth	Field Strength (V/m)	Observation	Result
80 ~ 1000	V&H	0	3	Note	PASS
80 ~ 1000	V&H	90	3	Note	PASS
80 ~ 1000	V&H	180	3	Note	PASS
80 ~ 1000	V&H	270	3	Note	PASS

NOTE: There was no change compared with the initial operation during the test.



8.5. ELECTRICAL FAST TRANSIENT (EFT)

8.5.1. TEST SPECIFICATION

Basic Standard: EN 61000-4-4

Test Voltage: Power Line: 1 KV
Signal/Control Line: 0.5 KV

Polarity: Positive & Negative

Impulse Frequency: 5 kHz

Impulse Wave-shape: 5/50 ns

Burst Duration: 15 ms

Burst Period: 300 ms

Test Duration: Not less than 1 min.

8.5.2. TEST INSTRUMENT

Table with 5 columns: Name of Equipment, Manufacturer, Model, Serial Number, Calibration Due. Rows include EFT Generator, Capacitive Clamp, and Software.

NOTE: 1. The calibration interval of the above test instruments is 12 months and the calibrations are traceable to NML/ROC and NIST/USA.
2. N.C.R.= No Calibration required

8.5.3. TEST PROCEDURE (please refer to measurement standard or CCS SOP PA-024)

- a) Both positive and negative polarity discharges were applied.
b) The length of the " hot wire " from the coaxial output of the EFT generator to the terminals on the EUT should not exceed 0.5 meter.
c) The duration time of each test sequential was 1 minute.
d) The transient/burst waveform was in accordance with EN 61000-4-4, 5/50ns.

8.5.4. TEST SETUP

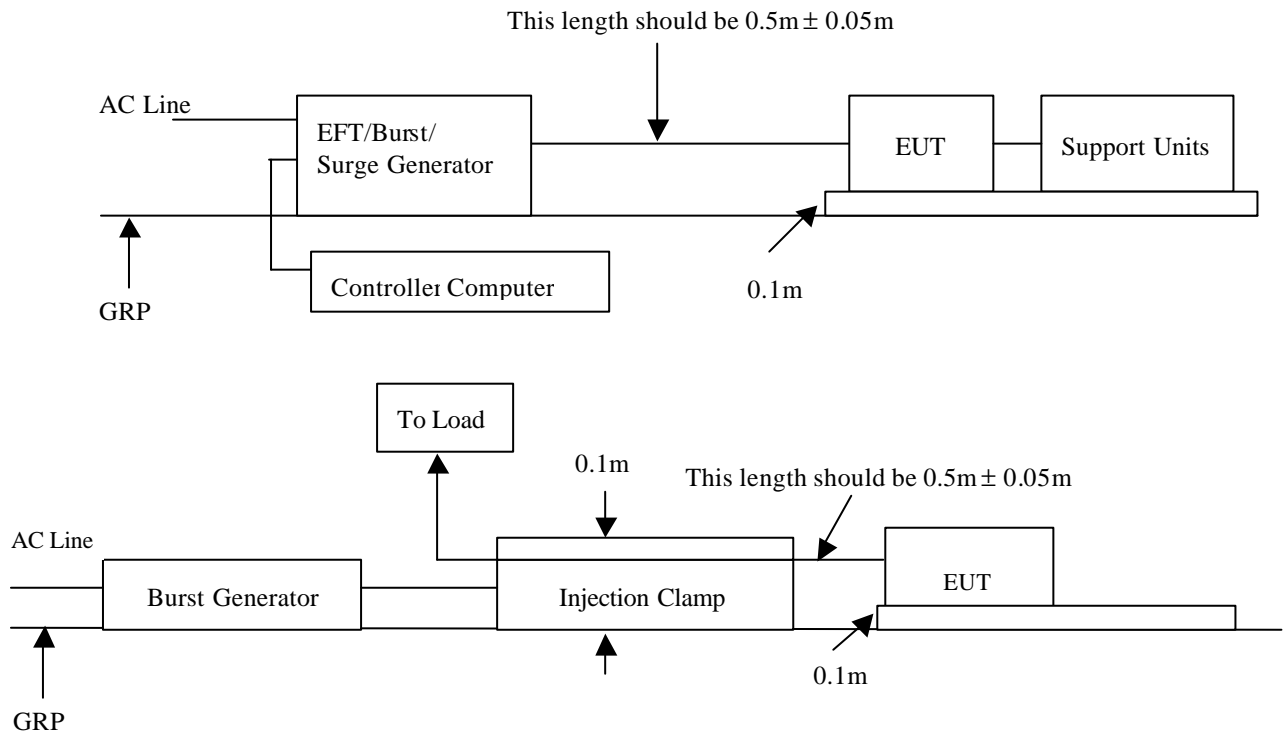

- For the actual test configuration, please refer to the related item – Photographs of the Test Configuration.

NOTE:

TABLETOP EQUIPMENT

The configuration consisted of a wooden table (0.1m high) standing on the Ground Reference Plane. The GRP consisted of a sheet of aluminum (at least 0.25mm thick and 2.5m square) connected to the protective grounding system. A minimum distance of 0.5m was provided between the EUT and the walls of the laboratory or any other metallic structure.

FLOOR STANDING EQUIPMENT

The EUT installed in a representative system as described in section 7 of IEC 61000-4-4 and its cables, were isolated from the Ground Reference Plane by an insulating support that is 0.1-meter thick. The GRP consisted of a sheet of aluminum (at least 0.25mm thick and 2.5m square) connected to the protective grounding system.



8.5.5. TEST RESULTS

Temperature	18°C	Humidity	58% RH
Pressure	1008mbar	Tested By	John Yen
Required Passing Performance		Criterion B	

Test Point	Polarity	Test Level (KV)	Performance Criterion	Observation	Result
L 1	+/-	1	<input checked="" type="checkbox"/> A <input type="checkbox"/> B	Note <input checked="" type="checkbox"/> 1 <input type="checkbox"/> 2	PASS
L 2	+/-	1	<input checked="" type="checkbox"/> A <input type="checkbox"/> B	Note <input checked="" type="checkbox"/> 1 <input type="checkbox"/> 2	PASS
L 1 – L 2	+/-	1	<input checked="" type="checkbox"/> A <input type="checkbox"/> B	Note <input checked="" type="checkbox"/> 1 <input type="checkbox"/> 2	PASS
PE	+/-	1	<input checked="" type="checkbox"/> A <input type="checkbox"/> B	Note <input checked="" type="checkbox"/> 1 <input type="checkbox"/> 2	PASS
L – PE	+/-	1	<input checked="" type="checkbox"/> A <input type="checkbox"/> B	Note <input checked="" type="checkbox"/> 1 <input type="checkbox"/> 2	PASS
N – PE	+/-	1	<input checked="" type="checkbox"/> A <input type="checkbox"/> B	Note <input checked="" type="checkbox"/> 1 <input type="checkbox"/> 2	PASS
L – N – PE	+/-	1	<input checked="" type="checkbox"/> A <input type="checkbox"/> B	Note <input checked="" type="checkbox"/> 1 <input type="checkbox"/> 2	PASS
RJ45 UTP CABLE	+/-	0.5	<input checked="" type="checkbox"/> A <input type="checkbox"/> B	Note <input checked="" type="checkbox"/> 1 <input type="checkbox"/> 2	PASS

NOTE: 1. There was no change compared with initial operation during the test.



8.6. SURGE IMMUNITY TEST

8.6.1. TEST SPECIFICATION

Basic Standard:	EN 61000-4-5
Wave-Shape:	Combination Wave 1.2/50 us Open Circuit Voltage 8/20 us Short Circuit Current
Test Voltage:	Power Line ~ Line to Line: 1 KV; Line to Ground: 2 KV
Surge Input/Output:	Power Line: L1-L2 / L1-PE / L2-PE
Generator Source Impedance:	2 ohm between networks 12 ohm between network and ground
Polarity:	Positive/Negative
Phase Angle:	0° / 90° / 180° / 270°
Pulse Repetition Rate:	1 time / min. (maximum)
Number of Tests:	5 positive and 5 negative at selected points

8.6.2. TEST INSTRUMENT

Immunity Shield Room				
Name of Equipment	Manufacturer	Model	Serial Number	Calibration Due
Surger Generator	Schaffner	BEST EMC V2.3	200031A024SC	11/05/2007
Signal and Data Lines Coupling Network	Schaffner	CDN118	19328	No Calibration Required
Software	WinBest.exe			

*NOTE: 1. The calibration interval of the above test instruments is 12 months and the calibrations are traceable to NML/ROC and NIST/USA.
2. N.C.R.= No Calibration required*



8.6.3. TEST PROCEDURE (please refer to measurement standard or CCS SOP PA-025)

a) For EUT power supply:

The surge is applied to the EUT power supply terminals via the capacitive coupling network. Decoupling networks are required in order to avoid possible adverse effects on equipment not under test that may be powered by the same lines, and to provide sufficient decoupling impedance to the surge wave. The power cord between the EUT and the coupling/decoupling networks was shorter than 2 meters in length.

b) For test applied to unshielded un-symmetrically operated interconnection lines of EUT:

The surge was applied to the lines via the capacitive coupling. The coupling / decoupling networks didn't influence the specified functional conditions of the EUT. The interconnection line between the EUT and the coupling/decoupling networks was shorter than 2 meters in length.

c) For test applied to unshielded symmetrically operated interconnection / telecommunication lines of EUT:

The surge was applied to the lines via gas arrestors coupling. Test levels below the ignition point of the coupling arrestor were not specified. The interconnection line between the EUT and the coupling/decoupling networks was shorter than 2 meters in length.

8.6.4. TEST SETUP

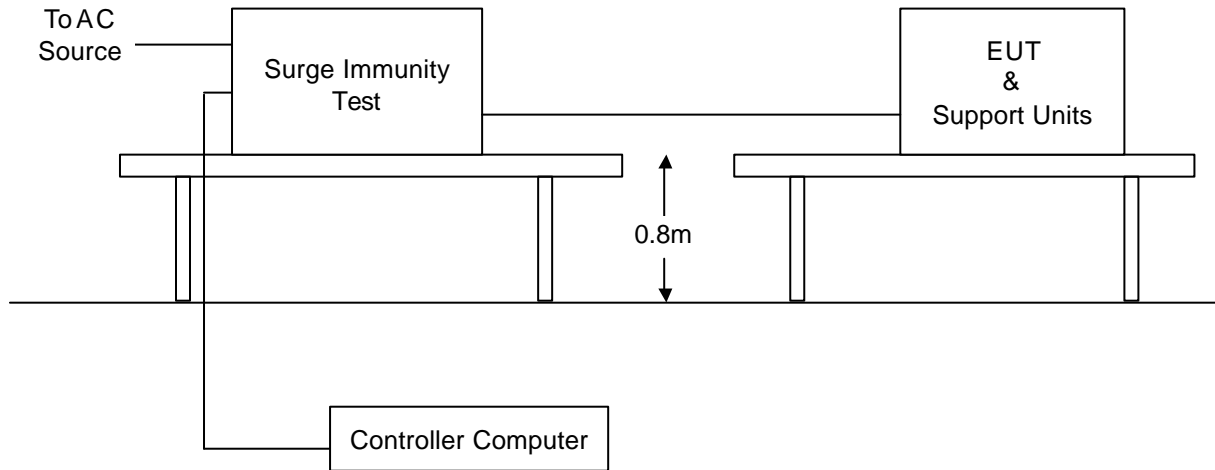

- For the actual test configuration, please refer to the related item – Photographs of the Test Configuration.



8.6.5. TEST RESULTS

Temperature	18°C	Humidity	58% RH
Pressure	1008mbar	Tested By	John Yen
Required Passing Performance		Criterion B	

Test Point	Polarity	Test Level (KV)	Performance Criterion	Observation	Result
L1 - L2	+/-	1	<input checked="" type="checkbox"/> A <input type="checkbox"/> B	Note <input checked="" type="checkbox"/> 1 <input type="checkbox"/> 2	PASS
L1 - PE	+/-	2	<input checked="" type="checkbox"/> A <input type="checkbox"/> B	Note <input checked="" type="checkbox"/> 1 <input type="checkbox"/> 2	PASS
L2 - PE	+/-	2	<input checked="" type="checkbox"/> A <input type="checkbox"/> B	Note <input checked="" type="checkbox"/> 1 <input type="checkbox"/> 2	PASS

NOTE: 1. (a) There was no change compared with initial operation during the test.

(b) Where normal functioning of LAN can't be achieved because of the impact of CDN on the EUT, no test be required.



8.7. CONDUCTED RADIO FREQUENCY DISTURBANCES (CS)

8.7.1. TEST SPECIFICATION

- Basic Standard:** EN 61000-4-6
- Frequency Range:** 0.15 MHz ~ 80 MHz
- Field Strength:** 3 Vrms
- Modulation:** 1kHz Sine Wave, 80%, AM Modulation
- Frequency Step:** 1 % of preceding frequency value
- Coupled cable:** Power Mains, Unshielded; RJ45 Line, Unshielded
- Coupling device:** CDN-M3 (3 wires), CDN-T8

8.7.2. TEST INSTRUMENT

CS Room				
Name of Equipment	Manufacturer	Model	Serial Number	Calibration Due
RF Generator	Schaffner	NSG 2070-1	1061	08/01/2007
CDN	Schaffner	CDN M316	19600	08/01/2007
CDN	Schaffner	CDN M216	19294	08/01/2007
CDN	FCC	FCC-801-M3-16A	99122	08/01/2007
EM Clamp	Schaffner	KEMZ 801	19227	03/04/2008
CDN	Schaffner	CDN T002	15881	01/10/2008
CDN	FCC	FCC-801-T8-RJ45	04025	07/03/2007
Attenuator	Schaffner	INA2070-1	2061	No Calibration Required
CDN	FCC	FCC-801-T4-RJ45	04031	08/01/2007
Software	Win2070.exe			

NOTE: 1. The calibration interval of the above test instruments is 12 months and the calibrations are traceable to NML/ROC and NIST/USA.
 2. N.C.R. = No Calibration required



8.7.3. TEST PROCEDURE (please refer to measurement standard or CCS SOP PA-026)

The EUT shall be tested within its intended operating and climatic conditions.

The test shall be performed with the test generator connected to each of the coupling and decoupling devices in turn, while the other non-excited RF input ports of the coupling devices are terminated by a 50-ohm load resistor.

The frequency range was swept from 150 kHz to 80 MHz, using the signal level established during the setting process and with a disturbance signal of 80 % amplitude. The signal was modulated with a 1 kHz sine wave, pausing to adjust the RF signal level or the switch coupling devices as necessary. The sweep rate was 1.5×10^{-3} decades/s. Where the frequency range is swept incrementally, the step size was 1 % of preceding frequency value from 150 kHz to 80 MHz.

The dwell time at each frequency was less than the time necessary for the EUT to be exercised, and able to respond. Sensitive frequencies such as clock frequency(ies) and harmonics or frequencies of dominant interest, was analyzed separately.

Attempts were made to fully exercise the EUT during testing, and to fully interrogate all exercise modes selected for susceptibility.

8.7.4. TEST SETUP

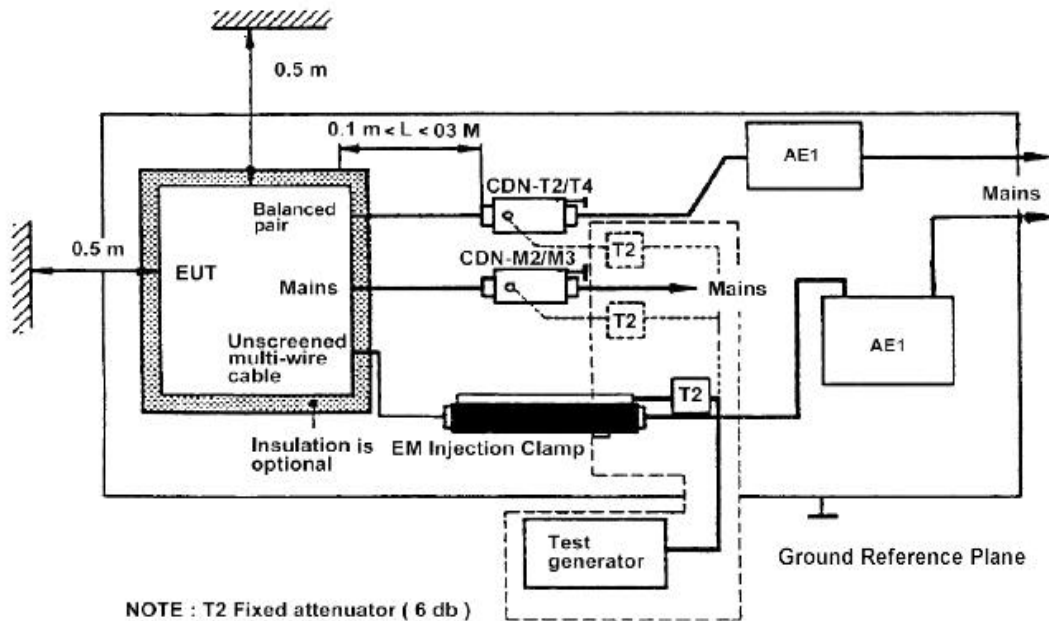

- Note: 1. The EUT is setup 0.1m above Ground Reference Plane*
 2. The CDNs and / or EM clamp used for real test depends on ports and cables configuration of EUT.

- For the actual test configuration, please refer to the related item – Photographs of the Test Configuration.

NOTE:

TABLE-TOP AND FLOOR-STANDING EQUIPMENT

The equipment to be tested is placed on an insulating support of 0.1 meters height above a ground reference plane. All relevant cables shall be provided with the appropriate coupling and decoupling devices at a distance between 0.1 meters and 0.3 meters from the projected geometry of the EUT on the ground reference plane.



8.7.5. TEST RESULTS

Temperature	19°C	Humidity	59% RH
Pressure	1009mbar	Tested By	John Yen
Required Passing Performance		Criterion A	

Frequency Band (MHz)	Field Strength (Vrms)	Cable	Injection Method	Performance Criterion	Observation	Result
0.15 ~ 80	3	AC Power Line (0.3m)	CDN-M3	<input checked="" type="checkbox"/> A <input type="checkbox"/> B	Note <input checked="" type="checkbox"/> 1 <input type="checkbox"/> 2	PASS
0.15 ~ 80	3	RJ 45 Line (0.3m)	CDN-T8	<input checked="" type="checkbox"/> A <input type="checkbox"/> B	Note <input checked="" type="checkbox"/> 1 <input type="checkbox"/> 2	PASS

NOTE: 1. There was no change compared with initial operation during the test.



8.8. POWER FREQUENCY MAGNETIC FIELD

8.8.1. TEST SPECIFICATION

Basic Standard: EN 61000-4-8

Frequency Range: 50Hz,

Field Strength: 1 A/m

Observation Time: 1 minute

Inductance Coil: Rectangular type, 1mx1m

8.8.2. TEST INSTRUMENT

Immunity Shield Room				
Name of Equipment	Manufacturer	Model	Serial Number	Calibration Due
Induction Coil Interface	Schaffner	INA 21141	6009	No Calibration Required
5KVA AC Power Source	Schaffner	NSG 1007	55131	No Calibration Required
TRMS Clamp Meter	CHY	932C	2K0900285	10/13/2007

NOTE: 1. The calibration interval of the above test instruments is 12 months and the calibrations are traceable to NML/ROC and NIST/USA. 2. N.C.R. = No Calibration required

8.8.3. TEST PROCEDURE (please refer to measurement standard or CCS SOP PA-027)

- a) The equipment is configured and connected to satisfy its functional requirements. It shall be placed on the GRP with the interposition of a 0.1m-thick insulating support.
- b. The equipment cabinets shall be connected to the safety earth directly on the GRP via the earth terminal of the EUT.
- c. The power supply, input and output circuits shall be connected to the sources of power supply, control and signal.
- d. The cables supplied or recommended by the equipment manufacturer shall be used. 1 meter of all cables used shall be exposed to the magnetic field.

8.8.4. TEST SETUP

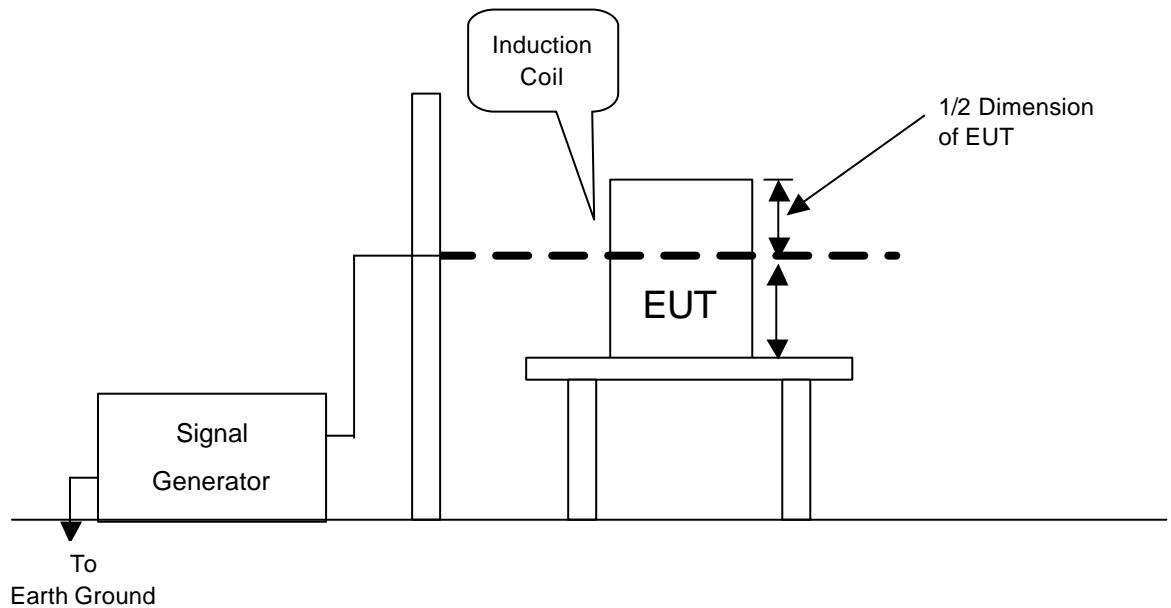

- For the actual test configuration, please refer to the related item – Photographs of the Test Configuration.

NOTE:

TABLETOP EQUIPMENT

The equipment shall be subjected to the test magnetic field by using the induction coil of standard dimension (1 m x 1 m). The induction coil shall then be rotated by 90 degrees in order to expose the EUT to the test field with different orientations.

FLOOR-STANDING EQUIPMENT

The equipment shall be subjected to the test magnetic field by using induction coils of suitable dimensions. The test shall be repeated by moving and shifting the induction coils, in order to test the whole volume of the EUT for each orthogonal direction. The test shall be repeated with the coil shifted to different positions along the side of the EUT, in steps corresponding to 50 % of the shortest side of the coil. The induction coil shall then be rotated by 90 degrees in order to expose the EUT to the test field with different orientations.



8.8.5. TEST RESULTS

Temperature	N/A	Humidity	N/A
Pressure	N/A	Tested By	N/A
Required Passing Performance		Criterion A	

DIRECTION	Field Strength (A/m)	Performance Criterion	OBSERVATION	RESULTS
X	1	A	Note	N/A
Y	1	A	Note	N/A
Z	1	A	Note	N/A

NOTE: The EUT is not containing any component that is susceptible to a 50 Hz or 60 Hz magnetic field. Therefore, this requirement is not applicable to the EUT.



8.9. VOLTAGE DIP & VOLTAGE INTERRUPTIONS

8.9.1. TEST SPECIFICATION

Basic Standard: EN 61000-4-11

Test duration time: Minimum three test events in sequence

Interval between event: Minimum 10 seconds

Phase Angle: 0° / 45° / 90° / 135° / 180° / 225° / 270° / 315° / 360°

Test cycle: 3 times

8.9.2. TEST INSTRUMENT

Immunity shielded room				
Name of Equipment	Manufacturer	Model	Serial Number	Calibration Due
Dips/Interruption/Variations Tester	Schaffner	BEST EMC V2.3	200031A024SC	11/05/2007
Software	WinBest.exe			

NOTE: 1. The calibration interval of the above test instruments is 12 months and the calibrations are traceable to NML/ROC and NIST/USA.

2. N.C.R. = No Calibration required

8.9.3. TEST PROCEDURE (please refer to measurement standard or CCS SOP PA-028)

1. The EUT and support units were located on a wooden table, 0.8 m away from ground floor.
2. Setting the parameter of tests and then perform the test software of test simulator.
3. Conditions changes to occur at 0 degree crossover point of the voltage waveform.
4. Recording the test result in test record form.

8.9.4. TEST SETUP

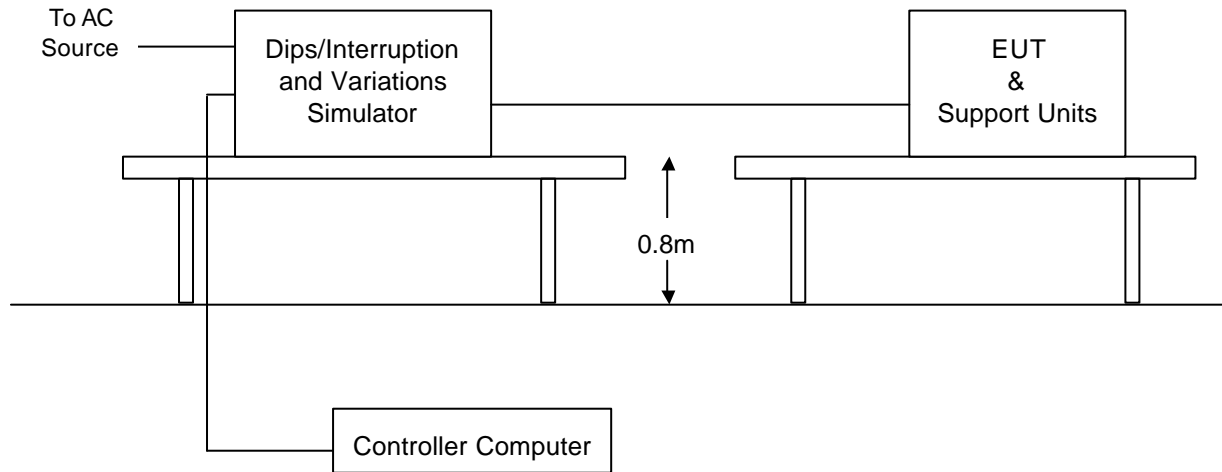

- For the actual test configuration, please refer to the related item – Photographs of the Test Configuration.



8.9.5. TEST RESULTS

Temperature	18°C	Humidity	58% RH
Pressure	1008mbar	Tested By	John Yen
Required Passing Performance	Criterion B: >95% reduction 0.5 period Criterion C: 30% reduction 25 period & >95% reduction 250 period		

Test Power: 230Vac, 50Hz				
Voltage (% Reduction)	Duration (Period)	Performance Criterion	Observation	Test Result
>95	0.5	<input checked="" type="checkbox"/> A <input type="checkbox"/> B <input type="checkbox"/> C	Note <input checked="" type="checkbox"/> 1 <input type="checkbox"/> 2	PASS
30	25	<input checked="" type="checkbox"/> A <input type="checkbox"/> B <input type="checkbox"/> C	Note <input checked="" type="checkbox"/> 1 <input type="checkbox"/> 2	PASS
>95	250	<input type="checkbox"/> A <input type="checkbox"/> B <input checked="" type="checkbox"/> C	Note <input type="checkbox"/> 1 <input checked="" type="checkbox"/> 2	PASS

NOTE: 1. There was no change compared with initial operation during and after the test. No unintentional response was found during the test.

2. EUT shut down, but EUT can be auto recovered after power on.

9 PHOTOGRAPHS OF THE TEST CONFIGURATION CONDUCTED EMISSION TEST



CONDUCTED EMISSION TEST AT TELECOMMUNICATION PORTS
RJ45 Telecom Port with ISN (10Mbps & 100Mbps & 1Gbps)



RADIATED EMISSION TEST



Harmonic & Flick Test



ESD Test



RS Test



EFT Test



EFT For I/O Test



Surge Test



CS Test



CS For I/O Test



Voltage Dip Test

