



Spectrum Research & Testing Lab., Inc.
No. 101-10, Ling 8,
Shan-Tong Li, Chung-Li
City, Taoyuan, Taiwan,
R.O.C.

TEST REPORT

Reference No.:A04052006
Report No.:EMCA04052006
Page:1 of 51
Date:May 26, 2004

Product Name: Embedded Controller
Model No.: AEC-6810
Applicant: AAEON TECHNOLOGY INC.
5F, NO. 135, LANE 235, PAO CHIAO RD., HSIN-TIEN CITY,
TAIPEI, TAIWAN, R.O.C.

Date of Receipt: Feb. 26, 2004

Finished date of Test: Mar. 01, 2004

Applicable Standards: **Emission**

EN 55011:1998 Group 1 Class A

EN 61000-3-2 edition 2:2000

EN 61000-3-3:1995+A1:2001

Immunity

EN 61000-6-1:2001

- IEC 61000-4-2:1995+A1:1998+A2:2001

- IEC 61000-4-3:2002+A1:2002

- ENV 50204:1995

- IEC 61000-4-4:1995+A1:2001+A2:2001

- IEC 61000-4-5:1995+A1:2001

- IEC 61000-4-6:1996+A1:2001

- IEC 61000-4-8:1993+A1:2001

- IEC 61000-4-11:1994+A1:2001

We, **Spectrum Research & Testing Laboratory Inc.**, hereby certify that one sample of the above was tested in our laboratory with positive results according to the above-mentioned standards. The records in the report are an accurate account of the results. Details of the results are given in the subsequent pages of this report.

Checked By :

Sunyou Chen
(Sunyou Chen)

Date:

5/26/2004

Approved By :

JH
(Johnson Ho, Director)

Date:

5/26/2004

NVLAQ[®]

Lab Code: 200099-0



Table of Contents

1.	DOCUMENT POLICY AND TEST STATEMENT	5
1.1	DOCUMENT POLICY	5
1.2	TEST STATEMENT	5
2.	DESCRIPTION OF EUT AND TEST MODE	6
2.1	GENERAL DESCRIPTION OF EUT	6
2.2	DESCRIPTION OF EUT INTERNAL DEVICE.....	6
2.3	DESCRIPTION OF TEST MODE.....	6
3.	DESCRIPTION OF APPLIED STANDARDS	7
4.	EMISSION TEST.....	8
4.1	CONDUCTED EMISSION TEST FOR POWER PORT.....	8
4.1.1	CONDUCTED EMISSION LIMIT	8
4.1.2	TEST EQUIPMENT	8
4.1.3	TEST SETUP.....	9
4.1.4	TEST PROCEDURE.....	9
4.1.5	DESCRIPTION OF SUPPORT UNIT.....	10
4.1.6	EUT OPERATING CONDITION.....	10
4.1.7	TEST RESULT.....	11
4.2	RADIATED EMISSION TEST.....	12
4.2.1	RADIATED EMISSION LIMIT	12
4.2.2	TEST EQUIPMENT	12
4.2.3	TEST SET-UP	13
4.2.4	TEST PROCEDURE.....	13
4.2.5	DESCRIPTION OF SUPPORT UNIT.....	14
4.2.6	EUT OPERATING CONDITION.....	14
4.2.7	TEST RESULT	15
4.3	CURRENT HARMONICS TEST.....	16
4.3.2	TEST EQUIPMENT	17
4.3.3	TEST SETUP.....	17
4.3.4	TEST PROCEDURE.....	17
4.3.5	DESCRIPTION OF SUPPORT UNIT.....	17
4.3.6	EUT OPERATING CONDITION.....	17
4.3.7	TEST RESULT	18
4.4	VOLTAGE FLUCTUATIONS.....	19
4.4.1	LIMIT	19
4.4.2	TEST EQUIPMENT	20
4.4.3	TEST PROCEDURE.....	20
4.4.4	TEST SETUP.....	20
4.4.5	DESCRIPTION OF SUPPORT UNIT.....	20
4.4.6	EUT OPERATING CONDITION.....	20
4.4.7	TEST RESULT	21
5.	ELECTROSTATIC DISCHARGE IMMUNITY TEST	22
5.1	TEST EQUIPMENT.....	22
5.2	TEST PROCEDURE	22
5.3	TEST SET-UP	23



5.4	DESCRIPTION OF SUPPORT UNIT	24
5.5	EUT OPERATING CONDITION	24
5.6	TEST CONDITION AND PERFORMANCE CRITERION	24
5.7	SUMMARY OF TEST RESULT	25
6.	RADIATED IMMUNITY TEST	26
6.1	TEST EQUIPMENT	26
6.2	TEST PROCEDURE	26
6.3	TEST SETUP	27
6.4	DESCRIPTION OF SUPPORT UNIT	28
6.5	EUT OPERATING CONDITION	28
6.6	TEST CONDITION / PERFORMANCE CRITERIA	28
6.7	TEST RESULT	28
7.	RADIATED IMMUNITY TEST	29
7.1	TEST EQUIPMENT	29
7.2	TEST PROCEDURE	29
7.3	TEST SETUP	30
7.4	DESCRIPTION OF SUPPORT UNIT	31
7.5	EUT OPERATING CONDITION	31
7.6	TEST CONDITION / PERFORMANCE CRITERIA	31
7.7	TEST RESULT	31
8.	ELECTRICAL FAST TRANSIENT / BURST IMMUNITY TEST	32
8.1	TEST EQUIPMENT	32
8.2	TEST PROCEDURE	32
8.3	TEST SET-UP	33
8.4	DESCRIPTION OF SUPPORT UNIT	33
8.5	EUT OPERATING CONDITION	33
8.6	TEST CONDITION / PERFORMANCE CRITERIA	34
8.7	SUMMARY OF TEST RESULT	34
9.	SURGE TEST (POWER LINE)	35
9.1	TEST EQUIPMENT	35
9.2	TEST PROCEDURE	35
9.3	TEST SET-UP	35
9.4	DESCRIPTION OF SUPPORT UNIT	35
9.5	EUT OPERATING CONDITION	35
9.6	TEST CONDITION / PERFORMANCE CRITERIA	36
9.7	SUMMARY OF TEST RESULT	36
10.	INDUCED RF FIELDS (CONDUCTED SUSCEPTIBILITY) TEST	37
10.1	TEST EQUIPMENT	37
10.2	TEST PROCEDURE	38
10.3	TEST SET-UP	38
10.4	DESCRIPTION OF SUPPORT UNIT	38
10.5	EUT OPERATING CONDITION	38
10.6	TEST CONDITION / PERFORMANCE CRITERIA	39
10.7	SUMMARY OF TEST RESULT	39



Spectrum Research & Testing Lab., Inc.
No. 101-10, Ling 8,
Shan-Tong Li, Chung-Li
City, Taoyuan, Taiwan,
R.O.C.

TEST REPORT

Reference No.:A04052006
Report No.:EMCA04052006
Page:4 of 51
Date:May 26, 2004

11. POWER FREQUENCY MAGNETIC-FIELD TEST	40
11.1 TEST EQUIPMENT	40
11.2 TEST PROCEDURE	40
11.3 TEST SET-UP	40
11.4 DESCRIPTION OF SUPPORT UNIT	40
11.5 EUT OPERATING CONDITION	41
11.6 TEST CONDITION / PERFORMANCE CRITERIA.....	41
11.7 SUMMARY OF TEST RESULT	41
12. VOLTAGE DIPS, INTERRUPTS, VARIATIONS TEST	42
12.1 TEST EQUIPMENT	42
12.2 TEST PROCEDURE	42
12.3 TEST SET-UP	42
12.4 DESCRIPTION OF SUPPORT UNIT	42
12.5 EUT OPERATING CONDITION	42
12.6 TEST CONDITION / PERFORMANCE CRITERIA	43
12.7 SUMMARY OF TEST RESULT	43
13. PHOTOS OF TESTING.....	44
14. TERMS OF ABRIVATION	51



1. DOCUMENT POLICY AND TEST STATEMENT

1.1 DOCUMENT POLICY

- The report shall not be reproduced except in full, without the written approval of SRT Lab, Inc.
- The report must not be used by the applicant to claim that the product is endorsed by NVLAP, TÜV, NEMKO and SRT.
- The NVLAP logo applies only to the applicable standards specified in this report.

1.2 TEST STATEMENT

- The test results in the report apply only to the unit tested by SRT Lab.
- There was no deviation from the requirements of test standards during the test.
- AC power source, 230 VAC/50 Hz, was used during the test.
- The EN 61000-3-2 edition 2:2000(Harmonic test) and EN 61000-3-3:1995 +A1:2001(Flicker test) are not included in the scope of NVLAP logo usage.
- The EN 61000-3-2 edition 2:2000(Harmonic test) and EN 61000-3-3:1995 +A1:2001(Flicker test) are included in the scope of TÜV, NEMKO and SRT logo usage.

 Spectrum Research & Testing Lab., Inc. No. 101-10, Ling 8, Shan-Tong Li, Chung-Li City, Taoyuan, Taiwan, R.O.C.	<h1>TEST REPORT</h1>	Reference No.:A04052006 Report No.:EMCA04052006 Page:6 of 51 Date:May 26, 2004
--	----------------------	---

2. DESCRIPTION OF EUT AND TEST MODE

2.1 GENERAL DESCRIPTION OF EUT

PRODUCT	Embedded Controller
MODEL NO.	AEC-6810
POWER SUPPLY	AC230/50Hz
CABLE	0.27m unshielded Audio Cable 0.2m shielded Keyboard/Mouse Cable

NOTE :

Serial Numbers Difference:

AEC-6810-A1: Fanless Embedded Control PC with VIA 667MHz CPU

AEC-6810-A2: Fanless Embedded Control PC with VIA 667MHz CPU, W/ AC Adapter

AEC-6810-A3: Fanless Embedded Control PC with VIA 667MHz CPU, W/ HDD kit

AEC-6810-A4: Fanless Embedded Control PC with VIA 667MHz CPU, W/ AC Adapter

For more detailed information, please refer to the EUT's specification or user's manual provided by manufacturer.

2.2 DESCRIPTION OF EUT INTERNAL DEVICE

DEVICE	BRAND / MAKER	MODEL #	REMARK
HDD	FUJITSU	MHN2100AT	
RAM	ELPIDA	N/A	122MB

NOTE :

1. The CPU installed on EUT is VIA C3 667MHz, clock chip is 133MHz.

2. Frequency range to be measured.

Radiated emission is 30MHz to 1GHz.

2.3 DESCRIPTION OF TEST MODE

The EUT was pre-tested under the following video resolution:

800x600, 1024x768 and 1600x1200

The worst emission was found under 1600x1200 and therefore the test data of only this mode is recorded.



3. DESCRIPTION OF APPLIED STANDARDS

The EUT could be used in industrial environment information provided by the applicant, it must comply with the requirements of the following standards:

EN 55011:1998 Group 1 Class A

EN 61000-3-2 edition 2:2000

EN 61000-3-3:1995+A1:2001

EN 61000-6-1:2001

- IEC 61000-4-2:1995+A1:1998+A2:2001

- IEC 61000-4-3:2002+A1:2002

- ENV 50204:1995

- IEC 61000-4-4:1995+A1:2001+A2:2001

- IEC 61000-4-5:1995+A1:2001

- IEC 61000-4-6:1996+A1:2001

- IEC 61000-4-8:1993+A1:2001

- IEC 61000-4-11:1994+A1:2001

All tests have been performed and recorded as the above standards.



4. EMISSION TEST

4.1 CONDUCTED EMISSION TEST FOR POWER PORT

4.1.1 CONDUCTED EMISSION LIMIT

FREQUENCY (MHz)	Class A (dB μ V)		Class B (dB μ V)	
	Quasi-peak	Average	Quasi-peak	Average
0.15 - 0.5	79	66	66 - 56	56 - 46
0.5 - 5.0	73	60	56	46
5.0 - 30.0	73	60	60	50

NOTE:

1. The lower limit shall apply at the transition frequencies.
2. The limit decreases in line with the logarithm of the frequency in the range of 0.15 to 0.50 MHz.

4.1.2 TEST EQUIPMENT

The following test equipment was used for the test:

EQUIPMENT/ FACILITIES	SPECIFICATIONS	MANUFACTURER	MODEL#/ SERIAL#	DUE DATE OF CAL. & CAL. CENTER
EMI TEST RECEIVER	9 kHz TO 2750 MHz	ROHDE & SCHWARZ	ESCS30/ 830245/012	AUG. 2004 ETC
LISN (for EUT)	50 μ H, 50 ohm	SOLAR ELECTRONICS	8012-50-R-24-BNC / 924839	JUN. 2004 ETC
LISN (for Peripheral)	50 μ H, 50 ohm	SOLAR ELECTRONICS	9252-50-R-24-BNC / 951318	JUN. 2004 ETC
50 ohm TERMINATOR	50 ohm	HP	11593A/ 2	MAY 2005 ETC
COAXIAL CABLE	3m	SUNCITY	J400/ 3M	JUL. 2004 SRT
ISOLATION TRANSFORMER	N/A	APC	AFC-11015/ F102040016	N/A
FILTER	2 LINE, 30A	FIL.COIL	FC-943/ 771	N/A
GROUND PLANE	2.3M (H) x 2.4M (W)	SRT	N/A	N/A
GROUND PLANE	2.4M (H) x 2.4M (W)	SRT	N/A	N/A

NOTE: The calibration interval of the above test equipment is one year and the calibrations are traceable to NML/ROC and NIST/USA.



4.1.3 TEST SETUP

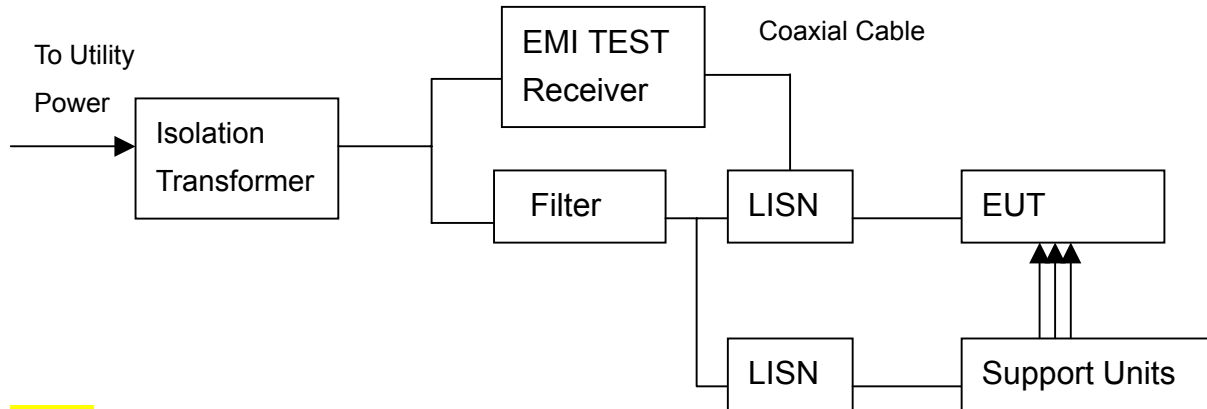

NOTE:

1. The EUT was put on a wooden table with 0.8m heights above ground plane, and 0.4m away from reference ground plane (> 2mx2m).
2. For the actual test configuration, please refer to the photos of testing.
3. The serial no. of the LISN connected to EUT is 951318.
4. The serial no. of the LISN connected to support units is 924839.

4.1.4 TEST PROCEDURE

The EUT was tested according to the requirement of EN 55011:1998 Group 1 Class A. The frequency spectrum from 0.15 MHz to 30 MHz was investigated. The LISN used was 50Ω/50μH as specified. All readings were quasi-peak and average values with 10 kHz resolution bandwidth of the test receiver. The EUT system was operated in all typical methods by users. Both lines of the power mains of EUT were measured and the cables connected to EUT and support units were moved to find the maximum emission levels for each frequency.

First, find the margin or higher points at least 6 points by software, then use manual to find the maximum data. The procedure is referred on the test procedure of SRT LAB.



4.1.5 DESCRIPTION OF SUPPORT UNIT

The EUT was configured by the requirement of EN 55022:1998+A1:2000+A2:2003. All interface ports were connected to the appropriate support units via specific cables. The support units and cables are listed below.

NO	DEVICE	BRAND	MODEL #	CABLE
1	MONITOR	SAMSUNG	PG17IS	1.5m unshielded power cord 1.5m shielded data cable
2	PRINTER	EPSON	STYLUS C20SX	1.8m unshielded power cord 1.5m shielded data cable
3	MODEM	ACEEX	DM-1414	1.8m unshielded DC power cable 1.5m shielded data cable
4	KEYBOARD	HP	2502C	1.5m shielded data cable
5	PS/2 MOUSE	COMBO	AM-737-C2	1.5m shielded data cable
6	USB MOUSE	HP	MO19UCA	1.5m shielded data cable
7	USB MOUSE	HP	MO19UCA	1.5m shielded data cable
8	USB MOUSE	HP	MO19UCA	1.5m shielded data cable
9	USB MOUSE	ACER	M-U69	1.5m shielded data cable
10	COM MOUSE	LOGITECH	M-M35	1.5m unshielded data cable
11	COM MOUSE	LOGITECH	M-S34	1.5m unshielded data cable
12	COM MOUSE	INTELLI	1.2A PS/2	1.5m unshielded data cable
13	TV	PANASONIC	TC-14S10R2	1.2m unshielded power cord
14	SPEAKER	J-S	J-205A	1.5m unshielded power cord 1.2m unshielded data cable
15	WALKMAN	AIWA	HS-P102	1.2m unshielded data cable
16	MIC	TAKY	UDM-606	1.8m unshielded data cable
17	CF CARD	PQI	N/A	N/A

NOTE : For the actual test configuration, please refer to the photos of testing.

4.1.6 EUT OPERATING CONDITION

1. Under WIN XP ran "EMI TEST", "WIN FCC" and "Media Player" programs.
2. PC sent "H" pattern or accessed the following peripherals directly or via EUT:
 - Color Monitor
 - RS232
 - Keyboard
 - Mouse
 - Printer
 - FDD
 - HDD
3. Accessed data from internet.



4.1.7 TEST RESULT

Temperature:	24 °C	Humidity:	58 %RH
Ferquency Range:	0.15 – 30 MHz	Tested Mode:	N/A
Receiver Detector:	Q.P. and AV.	Tested By:	Shunm Wang
		Tested Date:	May 22, 2004

Power Line Measured : Line

Freq. (MHz)	Correct. Factor (dB)	Reading Value (dB μ V)		Emission Level (dB μ V)		Limit (dB μ V)		Margin (dB)	
		Q.P.	AV.	Q.P.	AV.	Q.P.	AV.	Q.P.	AV.
0.174	0.20	52.1	42.2	52.3	42.4	79.0	66.0	-26.7	-23.6
0.177	0.20	47.9	38.2	48.1	38.4	79.0	66.0	-30.9	-27.6
3.685	0.20	40.8	33.4	41.0	33.6	73.0	60.0	-32.0	-26.4
4.140	0.20	36.7	25.2	36.9	25.4	73.0	60.0	-36.1	-34.6
10.308	0.20	36.5	28.1	36.7	28.3	73.0	60.0	-36.3	-31.7
22.444	0.20	40.5	33.1	40.7	33.3	73.0	60.0	-32.3	-26.8

Power Line Measured : Neutral

Freq. (MHz)	Correct. Factor (dB)	Reading Value (dB μ V)		Emission Level (dB μ V)		Limit (dB μ V)		Margin (dB)	
		Q.P.	AV.	Q.P.	AV.	Q.P.	AV.	Q.P.	AV.
0.171	0.20	53.7	39.9	53.9	40.1	79.0	66.0	-25.1	-25.9
0.174	0.20	54.6	40.5	54.8	40.7	79.0	66.0	-24.2	-25.3
3.744	0.20	39.9	35.6	40.1	35.8	73.0	60.0	-32.9	-24.3
4.031	0.20	40.5	33.0	40.7	33.2	73.0	60.0	-32.3	-26.8
14.460	0.20	39.7	29.0	39.9	29.2	73.0	60.0	-33.1	-30.8
24.615	0.20	37.0	27.4	37.2	27.6	73.0	60.0	-35.8	-32.4

NOTE :

1. Measurement uncertainty is +/-1.32dB
2. Emission level = Reading value + Correction factor
3. Correction Factor = Cable loss + Insertion loss of LISN
4. Margin value = Emission level - Limit
5. The emission of other frequencies were very low against the limit.
6. "-": The Quasi-peak reading value also meets average limit and measurement with the average detector is unnecessary.



4.2 RADIATED EMISSION TEST

4.2.1 RADIATED EMISSION LIMIT

EN 55011:1998 Group 1 limits of radiated emission measurement for frequency below 1000 MHz

FREQUENCY (MHz)	Class A (at 10m)	Class B (at 10m)
	dB μ V/m	dB μ V/m
30 – 230	40	30
230 - 1000	47	37

NOTE:

1. The lower limit shall apply at the transition frequencies.
2. Emission level (dB μ V/m) = 20 log Emission level (μ V/m).

4.2.2 TEST EQUIPMENT

The following test equipment was used during the radiated emission test:

EQUIPMENT/ FACILITIES	SPECIFICATIONS	MANUFACTURER	MODEL#/ SERIAL#	DUE DATE OF CAL. & CAL. CENTER
EMI TEST RECEIVER	20 MHz TO 1000 MHz	ROHDE & SCHWARZ	ESVS30/ 841977/003	AUG. 2004 ETC
BI-LOG ANTENNA	25 MHz TO 2 GHz	EMCO	3142/ 9701-1124	APR. 2005 SRT
OATS	3 – 10 M MEASUREMENT	SRT	SRT-1	APR. 2005 SRT
COAXIAL CABLE	25M	SUNCITY	J400/ 25M	AUG. 2004 SRT
FILTER	2 LINE, 30A	FIL.COIL	FC-943/ 869	N/A
FREQUENCY CONVERTER	N/A	APC	AFC-2KBB/ F100030031	AUG. 2004 SRT

NOTE:

1. The calibration interval of the above test equipment is one year and the calibrations are traceable to NML/ROC and NIST/USA.
2. The Open Area Test Site (SRT-1) is registered by FCC with No. 90957 and VCCI with No. R-1081.
3. The Open Area Test Site (SRT-2) is registered by FCC with No. 98458 and VCCI with No. R-1168.

4.2.3 TEST SET-UP

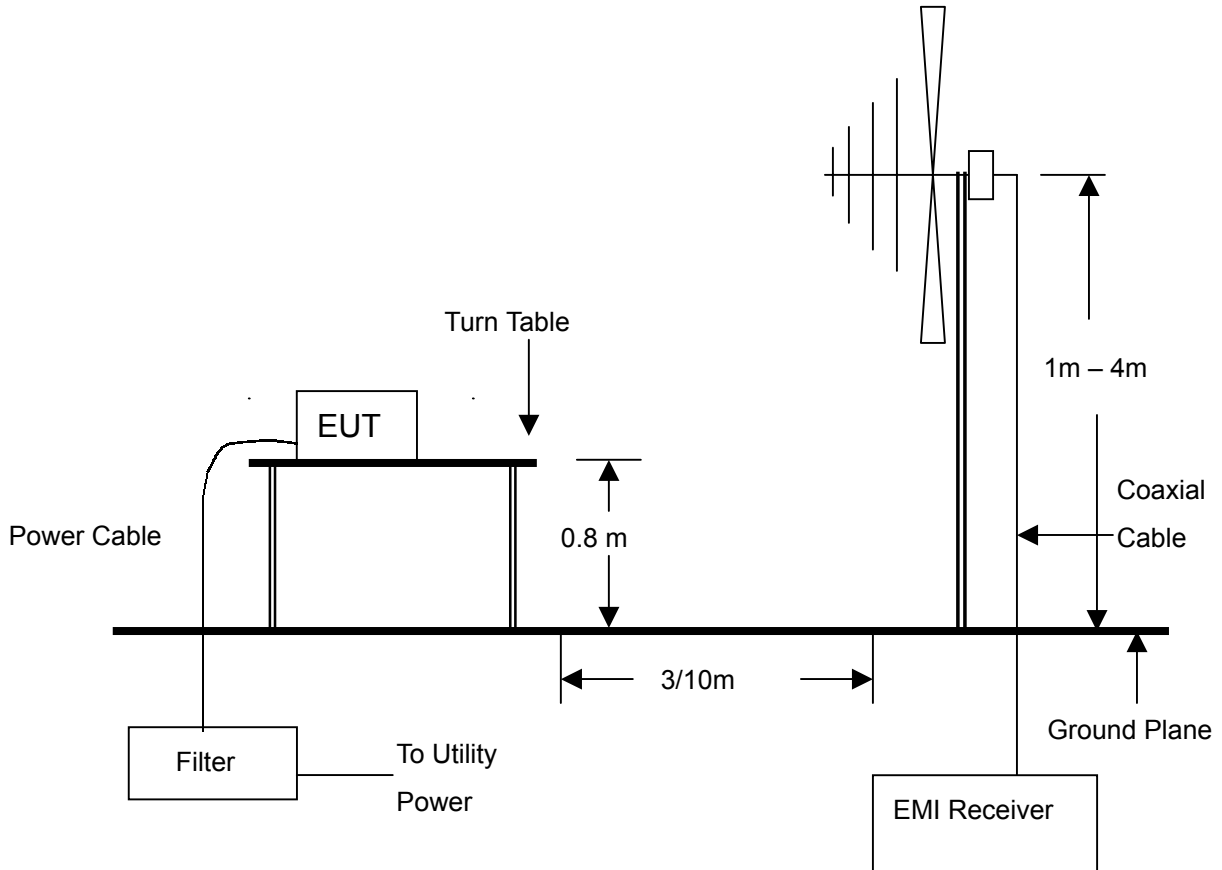

NOTE:

1. The EUT system was put on a wooden table with 0.8m heights above a ground plane.
2. For the actual test configuration, please refer to the photos of testing.

4.2.4 TEST PROCEDURE

The EUT was tested according to the requirement of EN 55011:1998 Group 1 Class A. The measurements were made at an open area test site with 10 meter measurement distance. The frequency spectrum measured from 30 MHz to 1 GHz. All readings were quasi-peak values with 120 kHz resolution bandwidth of the test receiver. The EUT system was operated in all typical methods by users. The cables connected to EUT and support units were moved to find the maximum emission levels for each frequency.

First, find the margin or higher points at least 6 points by software, then use manual to find the maximum data. The procedure is referred on the test procedure of SRT LAB.



**Spectrum Research &
Testing Lab., Inc.**
No. 101-10, Ling 8,
Shan-Tong Li, Chung-Li
City, Taoyuan, Taiwan,
R.O.C.

TEST REPORT

Reference No.:A04052006
Report No.:EMCA04052006
Page:14 of 51
Date:May 26, 2004

4.2.5 DESCRIPTION OF SUPPORT UNIT

Same as section 4.1.5 of this report.

4.2.6 EUT OPERATING CONDITION

Same as section 4.1.6 of this report.



4.2.7 TEST RESULT

Temperature:	27 °C	Humidity:	60 %RH
Ferquency Range:	30 – 1000 MHz	Measured Distance:	10m
Receiver Detector:	Q.P.	Tested Mode:	N/A
Tested By:	Shunm Wang	Tested Date:	May 22, 2004

Antenna Polarization:Horizontal

Frequency (MHz)	Cable Loss (dB)	Antenna Factor (dB/m)	Reading Data (dBμV)	Emission Level (dBμV/m)	Limit (dBμV/m)	Margin (dB)	AZ(°)	EL(m)
31.7160	0.62	9.59	15.2	25.4	40.0	-14.6	349.8	4.0
40.2200	0.68	9.50	14.6	24.8	40.0	-15.2	226.4	4.0
72.0050	0.94	5.80	17.8	24.5	40.0	-15.5	167.1	4.0
122.8840	1.19	5.77	27.2	34.2	40.0	-5.8	36.7	4.0
133.2730	1.21	7.81	26.9	35.9	40.0	-4.1	91.6	4.0
159.7490	1.36	7.78	27.1	36.2	40.0	-3.8	139.7	4.0

Antenna Polarization:Vertical

Frequency (MHz)	Cable Loss (dB)	Antenna Factor (dB/m)	Reading Data (dBμV)	Emission Level (dBμV/m)	Limit (dBμV/m)	Margin (dB)	AZ(°)	EL(m)
30.0000	0.61	9.60	16.7	26.9	40.0	-13.1	344.2	1.0
72.0070	0.94	5.80	18.7	25.4	40.0	-14.6	171.2	1.0
122.8840	1.19	5.77	25.4	32.4	40.0	-7.6	40.5	1.0
132.9440	1.20	7.62	25.1	33.9	40.0	-6.1	100.3	1.0
140.9710	1.24	9.10	17.8	28.1	40.0	-11.9	258.1	1.0
159.7480	1.36	7.78	24.8	33.9	40.0	-6.1	135.2	1.0

NOTE :

1. Measurement uncertainty is +/-2dB.
2. "": Measurement does not apply for this frequency.
3. Emission Level = Reading Value + Ant. Factor + Cable Loss.
4. The field strength of other emission frequencies were very low against the limit.



4.3 CURRENT HARMONICS TEST

4.3.1 LIMIT

For Class A Equipment

EVEN HARMONICS		ODD HARMONICS	
HARMONICS ORDER	LIMIT (Amp.)	HARMONICS ORDER	LIMIT (Amp.)
2	1.08	3	2.30
4	0.43	5	1.14
6	0.30	7	0.77
8 < n < 40	0.23 x 8 / n	9	0.40
		11	0.33
		13	0.21
		15 < n < 39	0.15 x 8 / n

For Class D Equipment

Harmonics Order n	Max. permissible harmonics current per watt (mA/W)	Max. permissible harmonics current (A)
Odd Harmonics only		
3	3.4	2.30
5	1.9	1.14
7	1.0	0.77
9	0.5	0.40
11	0.35	0.33
13	0.30	0.21
15 ≤ n ≤ 39	3.85 / n	0.15 x 15 / n

NOTE:

1. Class A and Class D are judged by test equipment automatically as per Section 5 of EN 61000-3-2 edition 2:2000
2. The above limits for Class D equipment are for all applications having an active input power > 75 W. No limits apply for equipment with an active input power up to and including 75 W.

4.3.2 TEST EQUIPMENT

EQUIPMENT / FACILITIES	MANUFACTURER	MODEL # / SERIAL #	DUE DATE OF CAL. & CAL. CENTER
MAIN UNIT	HP	6842A/ 3734A00212	APR. 2005 PRECISION

NOTE: The calibration interval of the above test equipment is one year and the calibrations are traceable to NML/ROC and NIST/USA.

4.3.3 TEST SETUP

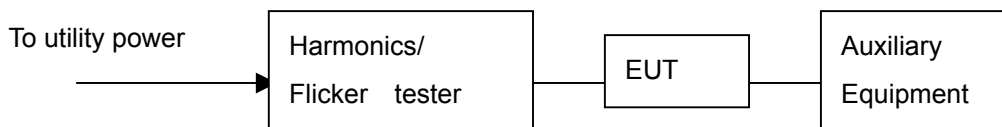

NOTE :

1. The EUT system was put on a wooden table with 0.8m high.
2. For the actual test configuration, please refer to the photos of testing.

4.3.4 TEST PROCEDURE

According to EN61000-3-2 edition 2:2000

4.3.5 DESCRIPTION OF SUPPORT UNIT

Same as section 4.1.5 of this report.

4.3.6 EUT OPERATING CONDITION

Same as section 4.1.6 of this report.



Spectrum Research & Testing Lab., Inc.
No. 101-10, Ling 8,
Shan-Tong Li, Chung-Li
City, Taoyuan, Taiwan,
R.O.C.

TEST REPORT

Reference No.:A04052006
Report No.:EMCA04052006
Page:18 of 51
Date:May 26, 2004

4.3.7 TEST RESULT

Temperature:	23 °C	Humidity:	58% RH
Fundamental Current:	0.100A	Max. Power	
Voltage:	225.6Vrms	Consumption:	20.6W
Power Factor:	0.371	Tested Mode:	N/A
Tested By:	Shunm Wang	Tested Date:	May 21, 2004

Maximum Reading Data:

Odd Harm. Order	Reading Data (A)	Limit (A)	Test Result
15	0.0491	0.1500	PASS



4.4 VOLTAGE FLUCTUATIONS

4.4.1 LIMIT

Short-term flicker (P_{st}) : 1.0

Long-term flicker (P_{lt}) : 0.65

Relative steady-state voltage change (D_c) : $\leq 3\%$

Relative voltage change characteristic ($D(t) > 3\%$; ($T_{D(t)}$) : ≤ 200 ms

Maximum relative voltage change (D_{max}) : $\leq 4\%$

TEST ITEM	LIMIT	NOTE
P_{st}	1.0	P_{st} means short-term flicker indicator.
P_{lt}	0.65	P_{lt} means long-term flicker indicator.
$T_{D(t)}$ (ms)	200	$T_{D(t)}$ means maximum time that $D(t)$ exceeds 3 %.
D_{max} (%)	4%	D_{max} means maximum relative voltage change.
D_c (%)	3%	D_c means relative steady-state voltage change

 Spectrum Research & Testing Lab., Inc. No. 101-10, Ling 8, Shan-Tong Li, Chung-Li City, Taoyuan, Taiwan, R.O.C.	<h1>TEST REPORT</h1>	Reference No.:A04052006 Report No.:EMCA04052006 Page:20 of 51 Date:May 26, 2004
--	----------------------	--

4.4.2 TEST EQUIPMENT

EQUIPMENT / FACILITIES	MANUFACTURER	MODEL # / SERIAL #	DUE DATE OF CAL. & CAL. CENTER
MAIN UNIT	HP	6842A/ 3734A00212	APR. 2005 PRECISION

NOTE: The calibration interval of the above test equipment is one year and the calibrations are traceable to NML/ROC and NIST/USA.

4.4.3 TEST PROCEDURE

According to EN 61000-3-3:1995+A1:2001

4.4.4 TEST SETUP

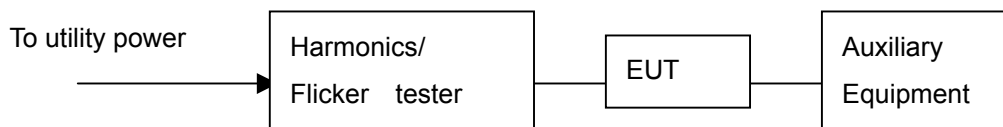

- NOTE :**
1. The EUT system was put on a wooden table with 0.8m high.
 2. For the actual test configuration, please refer to the photos of testing.

4.4.5 DESCRIPTION OF SUPPORT UNIT

Same as section 4.1.5 of this report.

4.4.6 EUT OPERATING CONDITION

Same as section 4.1.6 of this report.



4.4.7 TEST RESULT

Temperature:	23 °C	Humidity:	58% RH
Input Voltage:	225.6Vrms	Observation	
Ampere:	0.2Arms	Period:	1Hr
Power Factor:	0.351	Tested Mode:	N/A
Tested By:	Shunm Wang	Tested Date:	May 21, 2004

Test Result:

TEST PARAMETER	MEASUREMENT VALUE	LIMIT	TEST RESULT
P_{st}	0.07	1.0	PASS
P_{lt}	0.07	0.65	PASS
$T_{D(t)}$ (ms)	0	200	PASS
D_{max} (%)	0%	4%	PASS
D_c (%)	0%	3%	PASS

NOTE:

1. P_{st} means short-term flicker indicator.
2. P_{lt} means long-term flicker indicator.
3. $T_{D(t)}$ means maximum time that $D(t)$ exceeds 3 %.
4. D_{max} means maximum relative voltage change.
5. D_c means relative steady-state voltage change.
6. N/A: Not applicable.

 Spectrum Research & Testing Lab., Inc. No. 101-10, Ling 8, Shan-Tong Li, Chung-Li City, Taoyuan, Taiwan, R.O.C.	<h1>TEST REPORT</h1>	Reference No.:A04052006 Report No.:EMCA04052006 Page:22 of 51 Date:May 26, 2004
--	----------------------	--

5. ELECTROSTATIC DISCHARGE IMMUNITY TEST

5.1 TEST EQUIPMENT

EQUIPMENT / FACILITIES	MANUFACTURER	MODEL # / SERIAL #	DUE DATE OF CAL. & CAL. CENTER
ESD SIMULATOR	NOISEKEN	ESS-100L(A)/TC-815P/ 8099C02238/7099C02	NOV. 2004 ETC
HCP (1.6M x 0.8M)	SRT	WITH TWO 470k OHM CABLE	N/A
VCP (0.5M x 0.5M)	SRT	WITH TWO 470k OHM CABLE	N/A
GROUND PLANE (3.4M x 2.4M)	SRT	N/A	N/A

NOTE: The calibration interval of the above test equipment is one year and the calibrations are traceable to NML/ROC and NIST/USA.

5.2 TEST PROCEDURE

According to IEC/EN 61000-4-2:1995+A1:1998+A2:2001

5.3 TEST SET-UP

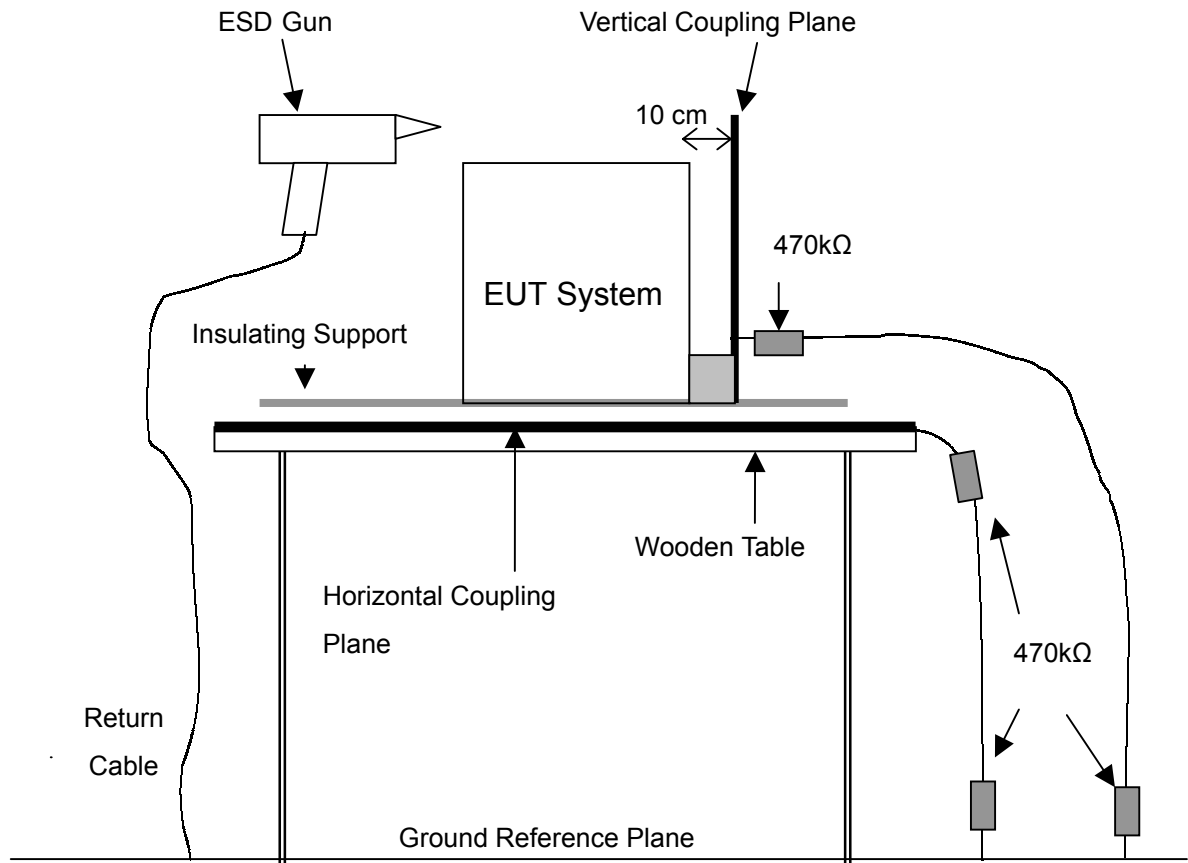

NOTE :

1. The wooden table should be 0.8m high for table top EUT and 0.1m for floor-standing EUT.
2. For the actual test configuration, please refer to the photos of testing.
3. A distance of 1m minimum was provided between EUT and walls / other metallic structure.



5.4 DESCRIPTION OF SUPPORT UNIT

Same as section 4.1.5 of this report.

5.5 EUT OPERATING CONDITION

Same as section 4.1.6 of this report.

5.6 TEST CONDITION AND PERFORMANCE CRITERION

1. Test condition

- (1) R-C Network : 330 Ω , 150 pF
- (2) Test level: Air Discharge : $\pm 2\text{kV}$, $\pm 4\text{kV}$, $\pm 8\text{kV}$
 - Contact discharge : $\pm 2\text{kV}$, $\pm 4\text{kV}$
 - HCP discharge : $\pm 2\text{kV}$, $\pm 4\text{kV}$
 - VCP discharge : $\pm 2\text{kV}$, $\pm 4\text{kV}$
- (3) Discharge mode : Single discharge
- (4) Discharge period : at least 1 s
- (5) Discharge polarity : Positive and Negative
- (6) Number of discharge : Minimum 50 times at each test point of contact discharge and at least 200 times of discharge to EUT in total. Minimum 10 times at each test area of air discharge selected.

- 2. Standard requirement : Criterion B

3. Performance criterion

- (1) Criterion A : Normal performance during test
- (2) Criterion B : Temporary degradation or loss of function or performance which is self-recoverable
- (3) Criterion C : Temporary degradation or loss of function or performance which requires operator intervention system reset



5.7 SUMMARY OF TEST RESULT

Temperature:	<u>24 °C</u>	Humidity:	<u>49% RH</u>
Tested Mode:	<u>N/A</u>	Tested By:	<u>Shunm Wang</u>
Atmospheric Air Pressure:	<u>101.2 kPa</u>	Tested Date:	<u>May 25, 2004</u>

Test Result : Criterion A pass

SEVERITY LEVEL	COUPLING MODE & TEST OBSERVATION			
	AIR DISCHARGE	CONTACT DISCHARGE	HCP	VCP
±2kV	A	A	A	A
±4kV	A	A	A	A
±8kV	A	NR	NR	NR

NOTE:

Description of test observation:

A: There was no change compared with initial operation during the test.

NR: No requirement

Description of test points:

1. Enclosure of EUT.
2. Power Switch of EUT.
3. Screws of EUT.
4. HCP.
5. VCP.



6. RADIATED IMMUNITY TEST

6.1 TEST EQUIPMENT

EQUIPMENT / FACILITIES	MANUFACTURER	MODEL # / SERIAL #	DUE DATE OF CAL. & CAL. CENTER
SIGNAL GENERATOR	HP	8648A/ 3636A022776	JUN. 2004 ETC
ANTENNA	SCHAFFNER CHASE	CBL6111/ 1188	AUG. 2004 SRT
FIELD SENSOR	AMPLIFIER RESEARCH	FP2000/ 28499	DEC. 2004 NML
POWER AMPLIFIER	AMPLIFIER RESEARCH	100W1000M1/ 19509	JUN. 2004 ETC
ANECHOIC CHAMBER	SRT	A05/ SRT005	OCT. 2004 SRT
V/M MONITOR	A.R.	FM2000/ 15970	N/A
MONITOR	SHIN	SI-609/ 905130	N/A
CCD	TOPVIEW	N/A/ 95113762	N/A
ABSORBER	ETS	N/A	N/A
COAXIAL CABLE	SUNCITY	J400/ 30CM	APR. 2005 SRT
COAXIAL CABLE	TIME	LMR-400/ 4M	APR. 2005 SRT

NOTE: The calibration interval of the above test equipment is one year and the calibrations are traceable to NML/ROC and NIST/USA.

6.2 TEST PROCEDURE

According to IEC/EN 61000-4-3:2002+A1:2002

6.3 TEST SETUP

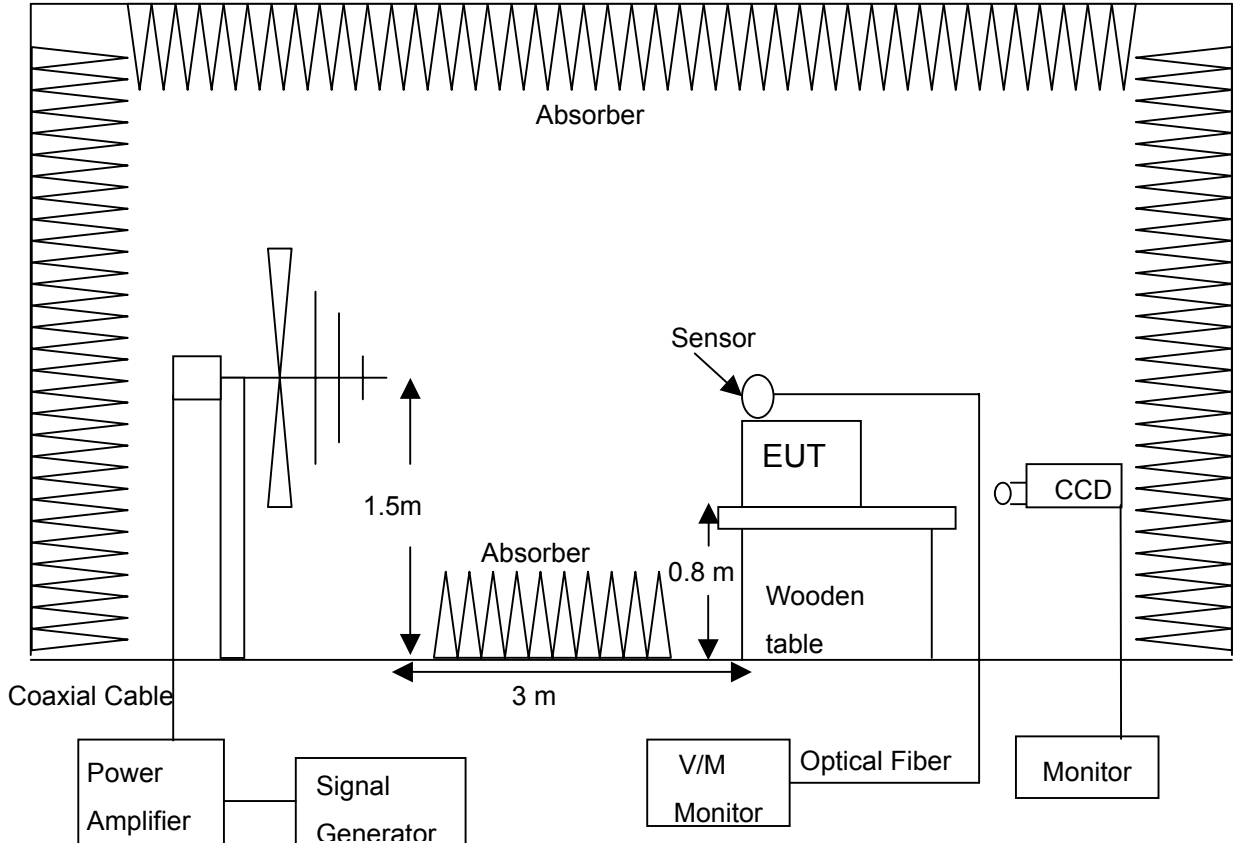

NOTE :

1. The wooden table should be 0.8m high for table top EUT and 0.1m for floor-standing EUT.
2. For the actual test configuration, please refer to the photos of testing.

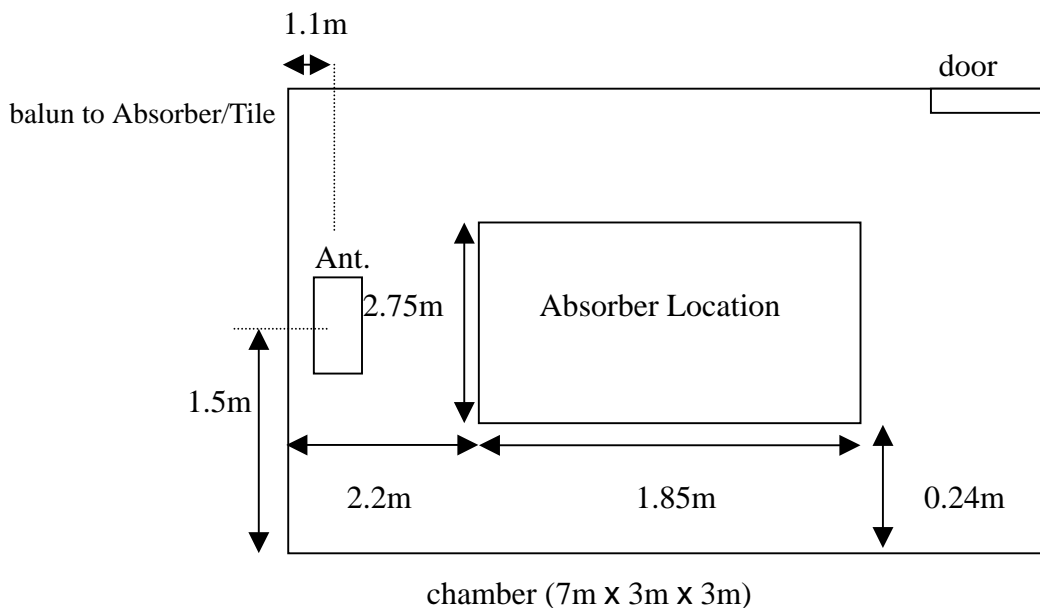



6.4 DESCRIPTION OF SUPPORT UNIT

Same as section 4.1.5 of this report.

6.5 EUT OPERATING CONDITION

Same as section 4.1.6 of this report.

6.6 TEST CONDITION / PERFORMANCE CRITERIA

1. Test condition

- (1) Source voltage and frequency : 230V/50Hz, single phase
- (2) Sweeping frequency : 80MHz – 1 GHz
- (3) Test level : 3V/m, the frequency step is 1%
- (4) The four sides of EUT are tested : front, rear, left, right
- (5) Modulation : 80%AM, 1kHz Dwell time for each frequency is 3 sec.
- (6) Antenna Polarization : Horizontal and Vertical
- (7) Standard requirement : Criterion A

2. Performance criterion

- (1) Criterion A : Normal performance during test
- (2) Criterion B : Temporary degradation or loss of function or performance which is self-recoverable.
- (3) Criterion C : Temporary degradation or loss of function or performance which requires operator intervention system reset.

6.7 TEST RESULT

Temperature:	<u>25°C</u>	Humidity:	<u>59% RH</u>
Tested Mode:	<u>N/A</u>	Tested By:	<u>Shunm Wang</u>
		Tested Date:	<u>May 25, 2004</u>

Test Result : Criterion A pass

FREQUENCY	LEVEL	MODULATION	DIRECTION	TEST RESULT (CRITERION)	
				H	V
80MHz - 1GHz	3V/m	80%AM, 1kHz	FRONT	A	A
80MHz - 1GHz	3V/m	80%AM, 1kHz	REAR	A	A
80MHz - 1GHz	3V/m	80%AM, 1kHz	LEFT	A	A
80MHz - 1GHz	3V/m	80%AM, 1kHz	RIGHT	A	A

NOTE:

Description of test observation:

A: There was no change compared with initial operation during the test.

	Spectrum Research & Testing Lab., Inc. No. 101-10, Ling 8, Shan-Tong Li, Chung-Li City, Taoyuan, Taiwan, R.O.C.	<h1>TEST REPORT</h1>	Reference No.:A04052006 Report No.:EMCA04052006 Page:29 of 51 Date:May 26, 2004
---	--	----------------------	--

7. RADIATED IMMUNITY TEST

7.1 TEST EQUIPMENT

EQUIPMENT / FACILITIES	MANUFACTURER	MODEL # / SERIAL #	DUE DATE OF CAL. & CAL. CENTER
SIGNAL GENERATOR	HP	8648A/ 3636A022776	JUN. 2004 ETC
ANTENNA	SCHAFFNER CHASE	CBL6111/ 1188	AUG. 2004 SRT
FIELD SENSOR	AMPLIFIER RESEARCH	FP2000/ 28499	DEC. 2004 NML
POWER AMPLIFIER	AMPLIFIER RESEARCH	100W1000M1/ 19509	JUN. 2004 ETC
ANECHOIC CHAMBER	SRT	A05/ SRT005	OCT. 2004 SRT
V/M MONITOR	A.R.	FM2000/ 15970	N/A
MONITOR	SHIN	SI-609/ 905130	N/A
CCD	TOPVIEW	N/A/ 95113762	N/A
ABSORBER	ETS	N/A	N/A
COAXIAL CABLE	SUNCITY	J400/ 30CM	APR. 2005 SRT
COAXIAL CABLE	TIME	LMR-400/ 4M	APR. 2005 SRT

NOTE: The calibration interval of the above test equipment is one year and the calibrations are traceable to NML/ROC and NIST/USA.

7.2 TEST PROCEDURE

According to ENV 50204:1995

7.3 TEST SETUP

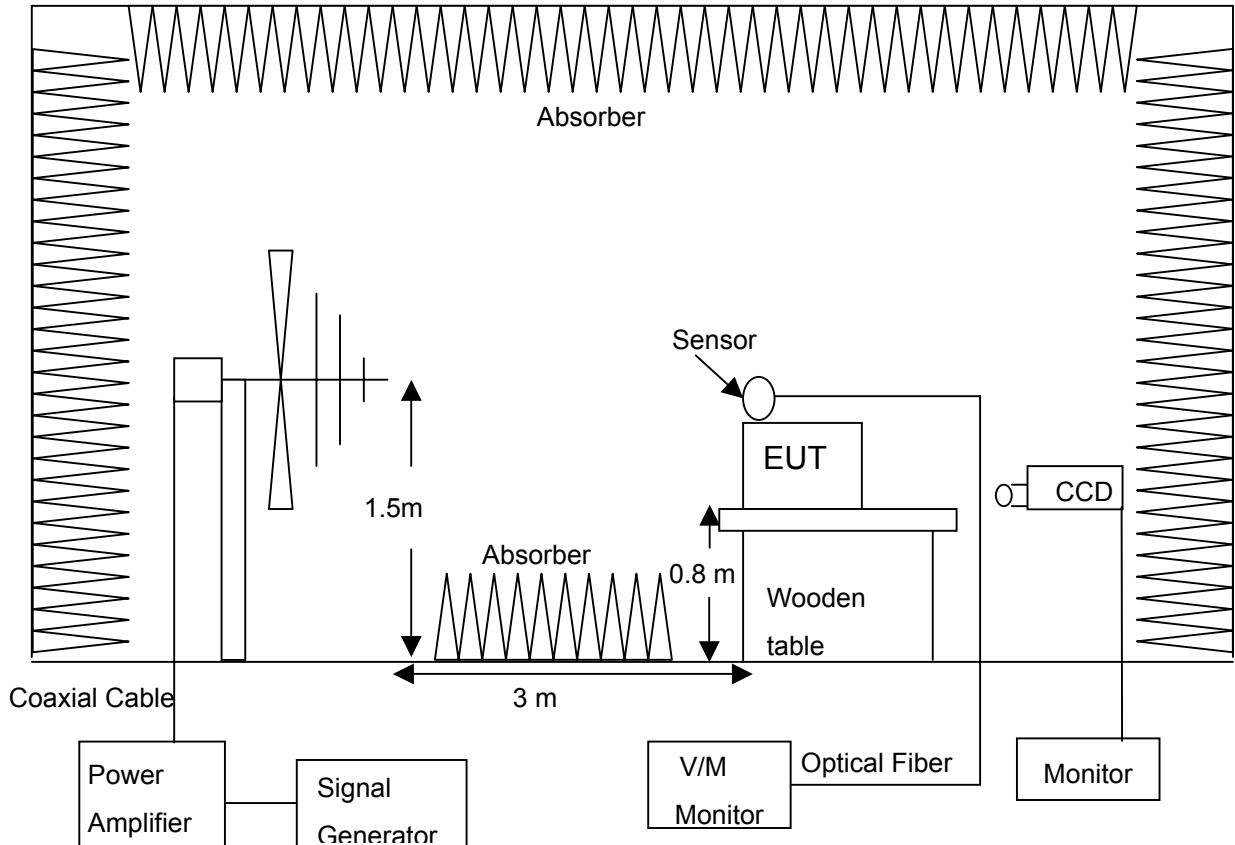

NOTE :

1. The wooden table should be 0.8m high for table top EUT and 0.1m for floor-standing EUT.
2. For the actual test configuration, please refer to the photos of testing.

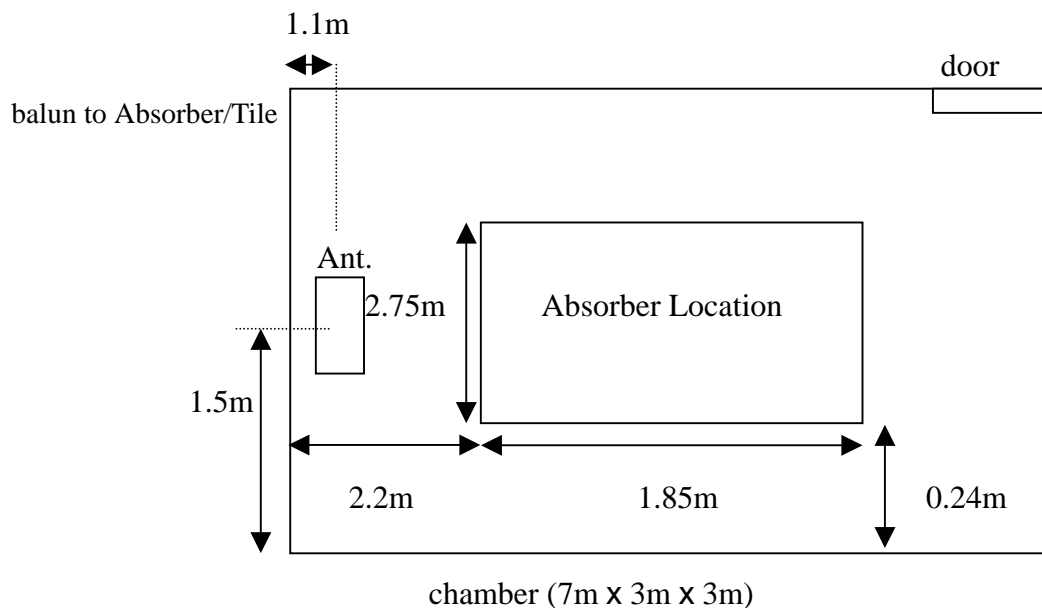



7.4 DESCRIPTION OF SUPPORT UNIT

Same as section 4.1.5 of this report.

7.5 EUT OPERATING CONDITION

Same as section 4.1.6 of this report.

7.6 TEST CONDITION / PERFORMANCE CRITERIA

1. Test condition

- (1) Source voltage and frequency : 230V/50Hz, single phase
- (2) Sweeping frequency : 900 MHz +/-5 MHz
- (3) Test level : 3V/m, the frequency step is 1%
- (4) The four sides of EUT are tested : front, rear, left, right
- (5) Modulation : 50% duty cycle(1Hz), 200Hz pluse Dwell time for each frequency at least 1sec..
- (6) Standard requirement : Criterion A

2. Performance criterion

- (1) Criterion A : Normal performance during test
- (2) Criterion B : Temporary degradation or loss of function or performance which is self-recoverable.
- (3) Criterion C : Temporary degradation or loss of function or performance which requires operator intervention system reset.

7.7 TEST RESULT

Temperature: 25°C Humidity: 59%RH
 Tested Mode: N/A Tested By: Shunm Wang
 Tested Date: May 25, 2004

Test Result : Criterion A pass

FREQUENCY	LEVEL	MODULATION	DIRECTION	TEST RESULT (CRITERION)	
				H	V
900MHz +/-5MHz	3V/m	50%pulse, 1Hz	FRONT	A	A
900MHz +/-5MHz	3V/m	50%pulse, 1Hz	REAR	A	A
900MHz +/-5MHz	3V/m	50%pulse, 1Hz	LEFT	A	A
900MHz +/-5MHz	3V/m	50%pulse, 1Hz	RIGHT	A	A

NOTE:

Description of test observation:

A: There was no change compared with initial operation during the test.



Spectrum Research & Testing Lab., Inc.
No. 101-10, Ling 8,
Shan-Tong Li, Chung-Li
City, Taoyuan, Taiwan,
R.O.C.

TEST REPORT

Reference No.:A04052006
Report No.:EMCA04052006
Page:32 of 51
Date:May 26, 2004

8. ELECTRICAL FAST TRANSIENT / BURST IMMUNITY TEST

8.1 TEST EQUIPMENT

EQUIPMENT / FACILITIES	MANUFACTURER	MODEL # / SERIAL #	DUE DATE OF CAL & CAL CENTER
EFT GENERATOR	HAEFELY	P90.1/PEFT.1/PHV41.2 083 448-08	FEB. 2005 ETC
CLAMP	HAEFELY	TRENCH / 080421-12	NOV. 2004 ETC
GROUND PLANE 2M x 3M	SRT	N/A	APR. 2005 SRT

8.2 TEST PROCEDURE

According to IEC/EN 61000-4-4:1995+A1:2001+A2:2001



8.3 TEST SET-UP

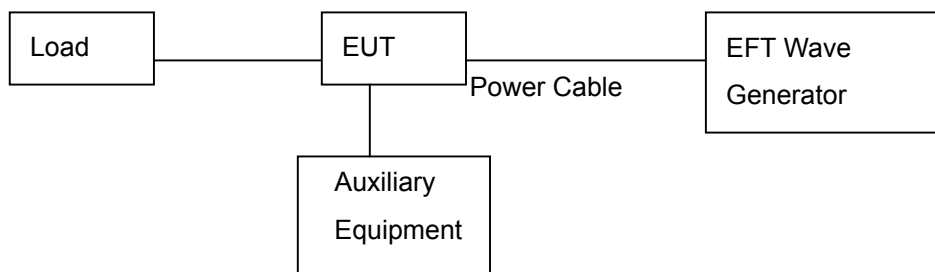
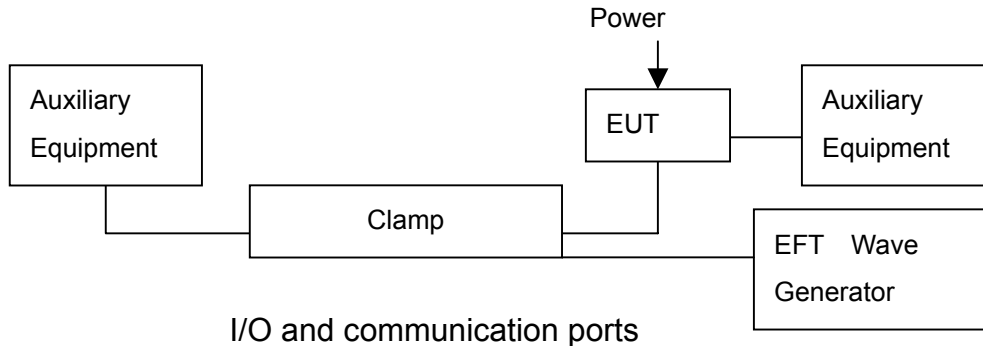

NOTE :

1. The EUT system was put on a wooden table with 0.8m heights for table top EUT and 0.1m for floor-standing EUT above ground reference plane.
2. For the actual test configuration, please refer to the photos of testing.
3. The minimum distance between the EUT and all other conductive structure was more than 0.5m.
4. The minimum distance between the coupling plates of the coupling clamps (if used) and all over conductive structures, except the ground plane beneath the coupling clamp and beneath the EUT was more than 0.5m.
5. The power cable connecting EUT was controlled under 1m.

8.4 DESCRIPTION OF SUPPORT UNIT

Same as section 4.1.5 of this report.

8.5 EUT OPERATING CONDITION

Same as section 4.1.6 of this report.



8.6 TEST CONDITION / PERFORMANCE CRITERIA

1. Test condition

- (1) Source voltage and frequency : 230V/50Hz, single phase
- (2) Pulse risetime and duration : 5ns / 50ns
- (3) Pulse repetition : 5kHz
- (4) Polarity : Positive Polarization and Negative Polarization
- (5) Burst duration and period : 15ms / 300ms
- (6) Test duration : ≥ 61sec each line
- (7) Time between test : 10Sec
- (8) Severity levels : Power Line ±1kV
Signal/Control Line ±0.5kV
- (9) Standard requirement : Criterion B

2. Performance criterion

- (1) Criterion A : Normal performance during test
- (2) Criterion B : Temporary degradation or loss of function or performance which is self-recoverable.
- (3) Criterion C : Temporary degradation or loss of function or performance which requires operator intervention system reset.

8.7 SUMMARY OF TEST RESULT

Temperature: 25 °C Humidity: 59% RH
 Tested Mode: N/A Tested By: Shunm Wang
 Atmospheric Air Pressure: 101.2 kPa Tested Date: May 25, 2004

Test Result : Criterion A pass

Voltage		0.25kV		0.5kV		1kV	
Polarity		+	-	+	-	+	-
Test Line	L1	NR	NR	A	A	A	A
	L2	NR	NR	A	A	A	A
	GND	NR	NR	A	A	A	A
	Signal/ Control Line	A	A	A	A	NR	NR

NOTE:

Description of test observation:

A: There was no change compared with initial operation during the test.

NR: No requirement

	Spectrum Research & Testing Lab., Inc. No. 101-10, Ling 8, Shan-Tong Li, Chung-Li City, Taoyuan, Taiwan, R.O.C.	<h1>TEST REPORT</h1>	Reference No.:A04052006 Report No.:EMCA04052006 Page:35 of 51 Date:May 26, 2004
---	--	----------------------	--

9. SURGE TEST (POWER LINE)

9.1 TEST EQUIPMENT

EQUIPMENT / FACILITIES	MANUFACTURER	MODEL # / SERIAL #	DUE DATE OF CAL. & CAL. CENTER
SURGE TEST (System Mainframe)	SCHAFFNER	NSG 2050 / 199904-057SC	JUL. 2004 SCHAFFNER
SURGE TEST (Impulse Network)	SCHAFFNER	PNW 2050 / 256	JUL. 2004 SCHAFFNER
SURGE TEST (Pulse Coupling Network)	SCHAFFNER	CDN 131/133 / 520	JUL. 2004 SCHAFFNER

9.2 TEST PROCEDURE

According to IEC/EN 61000-4-5:1995+A1:2001

9.3 TEST SET-UP



NOTE :

1. The EUT system was put on a wooden table with 0.8m heights above ground reference plane.
2. For the actual test configuration, please refer to the photos of testing.

9.4 DESCRIPTION OF SUPPORT UNIT

Same as section 4.1.5 of this report.

9.5 EUT OPERATING CONDITION

Same as section 4.1.6 of this report.



9.6 TEST CONDITION / PERFORMANCE CRITERIA

1. Test condition

- | | |
|--------------------------|---|
| (1) Test level | : Common mode : $\pm 0.5\text{kV}$, $\pm 1\text{kV}$, $\pm 2\text{kV}$
Differential mode : $\pm 0.25\text{kV}$, $\pm 0.5\text{kV}$, $\pm 1\text{kV}$ |
| (2) Pulse | : 5 |
| (3) Phase | : 0° , 90° , 180° , 270° |
| (4) Polarity | : Positive and Negative polarization |
| (5) Repetition | : 60 s |
| (6) Waveform | : 1.2/50 μs (open circuit) |
| (7) Standard requirement | : Criterion B |

2. Performance criterion

- | | |
|-----------------|--|
| (1) Criterion A | : Normal performance during test |
| (2) Criterion B | : Temporary degradation or loss of function or performance which is self-recoverable |
| (3) Criterion C | : Temporary degradation or loss of function or performance which requires operator intervention system reset |

9.7 SUMMARY OF TEST RESULT

Temperature:	<u>25 °C</u>	Humidity:	<u>59% RH</u>
Tested Mode:	<u>N/A</u>	Tested By:	<u>Shunm Wang</u>
Atmospheric Air Pressure:	<u>101.2 kPa</u>	Tested Date:	<u>May 25, 2004</u>

Test Result : Criterion A pass

Mode	Coupling	Voltage	Phase			
			0°	90°	180°	270°
Common	L + PE N + PE	+/-0.5kV	A	A	A	A
		+/-1kV	A	A	A	A
		+/-2kV	A	A	A	A
Differential	L + N	+/-0.25kV	A	A	A	A
		+/-0.5kV	A	A	A	A
		+/-1kV	A	A	A	A

NOTE:

Description of test observation:

A: There was no change compared with initial operation during the test.



Spectrum Research & Testing Lab., Inc.
No. 101-10, Ling 8,
Shan-Tong Li, Chung-Li
City, Taoyuan, Taiwan,
R.O.C.

TEST REPORT

Reference No.:A04052006
Report No.:EMCA04052006
Page:37 of 51
Date:May 26, 2004

10. INDUCED RF FIELDS (CONDUCTED SUSCEPTIBILITY) TEST

10.1 TEST EQUIPMENT

EQUIPMENT / FACILITIES	MANUFACTURER	MODEL # / SERIAL #	DUE DATE OF CAL. & CAL. CENTER	FINAL TEST BE USED
EM INJECTION CLAMP	FCC	F-203I-23mm/110	MAY 2005 ETC	
POWER LINE CDN	FCC	FCC-801-M4-32A/9808	MAY 2004 ETC	
POWER LINE CDN	FCC	FCC-801-M5-32A/9812	MAY 2005 ETC	
POWER LINE CDN	FCC	FCC-801-M1-32A/9820	MAY 2005 ETC	
SIGNAL LINE CDN	FCC	FCC-801-T2/9830	MAY 2005 ETC	
SIGNAL LINE CDN	FCC	FCC-801-T4/9831	MAY 2004 ETC	√
SIGNAL LINE CDN	FCC	FCC-801-T6/9832	MAY 2005 ETC	
SIGNAL LINE CDN	FCC	FCC-801-S9/9843	MAY 2004 ETC	
POWER LINE CDN	FCC	FCC-801-M2-32A/9840	NOV. 2004 ETC	
SIGNAL GENERATOR	HP	8648A/ 3636A02776	JUN. 2004 ETC	√
POWER AMPLIFIER	A.R.	150A100A/ 19553	MAY 2005 ETC	√
DUAL DIRECTION COULPER	A.R.	DC2600/ 25893	AUG. 2004 ETC	√
POWER METER	HP	435A/8481A/ 1810A08277	JAN 2005 ETC	√
SIGNAL LINE CDN	FCC	FCC-801-S25/ 9845	MAY 2005 ETC	
POWER LINE CDN	FCC	FCC-801-M3-32A/ 9874	MAY 2005 ETC	√
T2	EM-TEST	ATT6/75/ 1001-40	N/A	√
COAXIAL CABLE	SUNCITY	CABLE14/ #14-1M	APR. 2005 SRT	√
COAXIAL CABLE	SUNCITY	CABLE05/ #5-5M	APR. 2005 SRT	√
COAXIAL CABLE	SUNCITY	J400/ 2M	APR. 2005 SRT	√



10.2 TEST PROCEDURE

According to IEC/EN 61000-4-6:1996+A1:2001

10.3 TEST SET-UP

(1) For CDN injection :

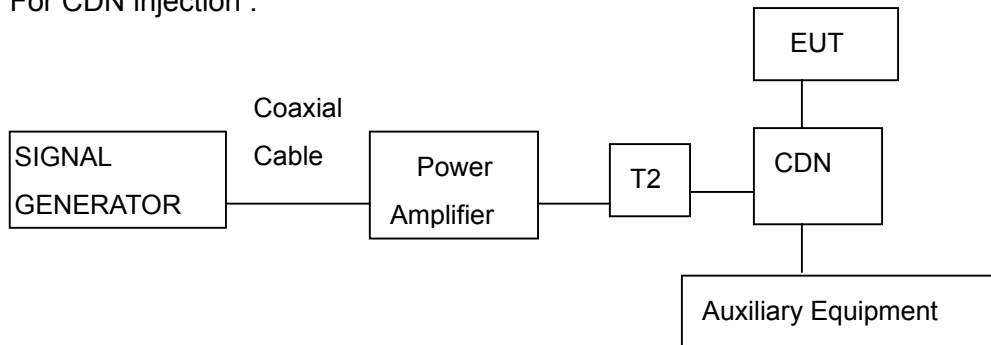

(2) For Clamp injection :

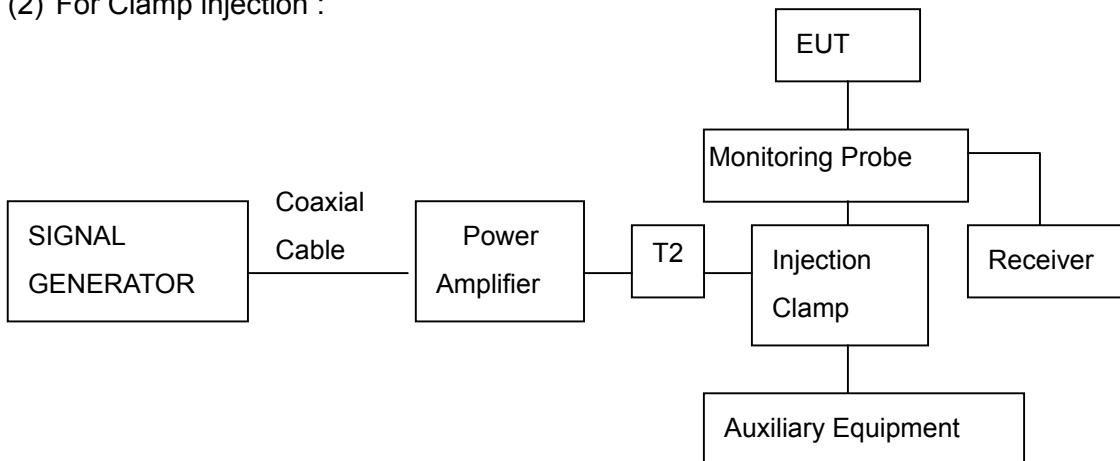

NOTE :

1. The EUT system was put on a wooden table with 0.1m heights above ground.
2. For the actual test configuration, please refer to the photos of testing.
3. The distance between CDN(Clamp) and EUT was controlled between 0.1m and 0.3m.
4. The model no. of the CDN connected to EUT is FCC-801-M3-32A.

10.4 DESCRIPTION OF SUPPORT UNIT

Same as section 4.1.5 of this report.

10.5 EUT OPERATING CONDITION

Same as section 4.1.6 of this report.



10.6 TEST CONDITION / PERFORMANCE CRITERIA

1. Test condition

- (1) Source voltage and frequency : 230 V/ 50 Hz, single phase
- (2) Sweeping frequency : 150 kHz – 80 MHz
- (3) Test level : 3 V, the frequency step is 1%
- (4) Polarity : Positive and Negative polarization
- (5) Modulation : AM 80%, 1 kHz
- (6) Dwell time for each frequency : 3 sec
- (7) Standard requirement : Criterion A

2. Performance criterion

- (1) Criterion A : Normal performance during test
- (2) Criterion B : Temporary degradation or loss of function or performance which is self-recoverable
- (3) Criterion C : Temporary degradation or loss of function or performance which requires operator intervention system reset

10.7 SUMMARY OF TEST RESULT

Temperature:	<u>25°C</u>	Humidity:	<u>59% RH</u>
Tested Mode:	<u>N/A</u>	Tested By:	<u>Shunm Wang</u>
		Tested Date:	<u>May 25, 2004</u>

Test Result : Criterion A pass

FREQUENCY	LEVEL	MODULATION	INJECTION METHOD	TEST RESULT (CRITERION)
150kHz - 80MHz	3V	80% AM, 1 kHz	M3	A
150kHz - 80MHz	3V	80% AM, 1 kHz	T4	A

NOTE:

Description of test observation:

A: There was no change compared with initial operation during the test.



11. POWER FREQUENCY MAGNETIC-FIELD TEST

11.1 TEST EQUIPMENT

EQUIPMENT / FACILITIES	MANUFACTURER	MODEL # / SERIAL #	DUE DATE OF CAL. & CAL. CENTER
MAGNETIC FIELD TESTER	HAEFELY	MAG 100.1/ 080.015-04	JAN. 2005 SRT
MAGNETIC FIELD COIL	HAEFELY	MAG 100.1/ 080.015-04	JAN. 2005 SRT
MAGNETIC FIELD METER	F.W.BELL	4080/ 19990416	MAR. 2005 ITRI

11.2 TEST PROCEDURE

According to IEC/EN 61000-4-8:1993+A1:2001

11.3 TEST SET-UP

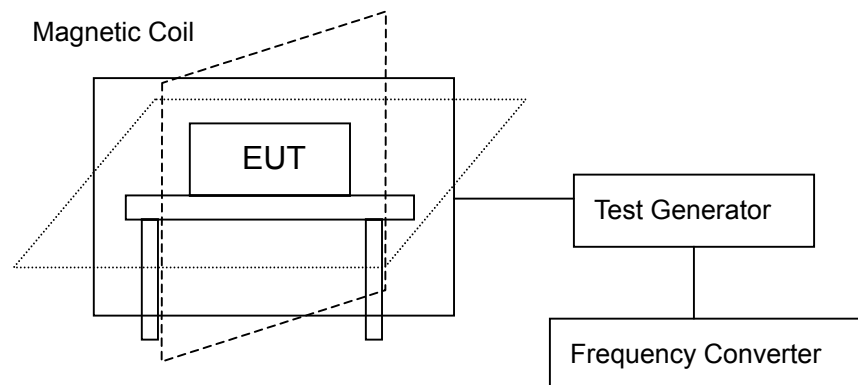

NOTE :

1. The EUT system was put on a wooden table with 0.8m heights above ground.
2. For the actual test configuration, please refer to the photos of testing
3. $1A/m = 12.56mG$, $3A/m = 37.68mG$, $10A/m = 125.6mG$,

11.4 DESCRIPTION OF SUPPORT UNIT

Same as section 4.1.5 of this report.



11.5 EUT OPERATING CONDITION

Same as section 4.1.6 of this report.

11.6 TEST CONDITION / PERFORMANCE CRITERIA

1. Test condition

- (1) Test axis : X, Y and Z axes
- (2) Test time : 5 min / each axis
- (3) Field strength : 3 A/m
- (4) Standard requirement : Criterion A

2. Performance criterion

- (1) Criterion A : Normal performance during test
- (2) Criterion B : Temporary degradation or loss of function or performance which is self-recoverable
- (3) Criterion C : Temporary degradation or loss of function or performance which requires operator intervention system reset

11.7 SUMMARY OF TEST RESULT

Temperature: 25°C Humidity: 59% RH
 Tested Mode: N/A Tested By: Shunm Wang
 Frequency of Magnetic Field: 50Hz, 60Hz Tested Date: May 25, 2004

Test Result : Criterion A pass

ORIENTATION	FIELD STRENGTH	TEST RESULT (CRITERION)
X	3 A/m	A
Y	3 A/m	A
Z	3 A/m	A

NOTE:

Description of test observation:

A: There was no change compared with initial operation during the test.

	Spectrum Research & Testing Lab., Inc. No. 101-10, Ling 8, Shan-Tong Li, Chung-Li City, Taoyuan, Taiwan, R.O.C.	<h1>TEST REPORT</h1>	Reference No.:A04052006 Report No.:EMCA04052006 Page:42 of 51 Date:May 26, 2004
---	--	----------------------	--

12. VOLTAGE DIPS, INTERRUPTS, VARIATIONS TEST

12.1 TEST EQUIPMENT

EQUIPMENT / FACILITIES	MANUFACTURER	MODEL # / SERIAL #	DUE DATE OF CAL. & CAL. CENTER
INTERFERENCE SIMULATOR	HAEFELY	PLINE 1610/ 083-732-05	MAR. 2005 ETC

12.2 TEST PROCEDURE

According to IEC/EN 61000-4-11:1994+A1:2001

12.3 TEST SET-UP

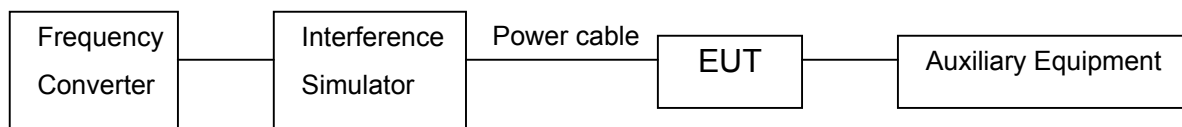

NOTE :

1. The EUT system was put on a wooden table with 0.8m heights above ground.
2. For the actual test configuration, please refer to the photos of testing.

12.4 DESCRIPTION OF SUPPORT UNIT

Same as section 4.1.5 of this report.

12.5 EUT OPERATING CONDITION

Same as section 4.1.6 of this report.



12.6 TEST CONDITION / PERFORMANCE CRITERIA

1. Test condition

- (1) Source voltage and frequency : 230V/50Hz, single phase
- (2) Test level : Dip depth 30%, 0.5 period;
Dip depth 60%, 5, 50 period;
interrupt 95%, 250 period.
- (3) Phase : 0°, 180°
- (4) Test duration : 2min each phase
- (5) Time between test : 10 sec
- (7) Standard requirement : Dip 30% : Criterion B pass;
Dip 60% : Criterion C pass;
Interrupt > 95% : Criterion C pass

2. Performance criterion

- (1) Criterion A : Normal performance during test
- (2) Criterion B : Temporary degradation or loss of function or performance which is self-recoverable.
- (3) Criterion C : Temporary degradation or loss of function or performance which requires operator intervention system reset.

12.7 SUMMARY OF TEST RESULT

Temperature:	<u>25°C</u>	Humidity:	<u>59% RH</u>
Tested Mode:	<u>N/A</u>	Tested By:	<u>Shunm Wang</u>
Tested Result:	<u>Pass</u>	Tested Date:	<u>May 25, 2004</u>

AC POWER	DIP DEPTH	INTERVAL	DIP TIME	TEST TIME	PHASE	TEST RESULT (Criterion)
230V/50Hz	30%	10 sec	0.5 period	2 min	0°	A
					180°	A
	60%	10 sec	5, 50 period	2 min	0°	A
					180°	A
	>95% (interrupt)	10 sec	250 period	2 min	0°	B
					180°	B

NOTE:

1. The power voltage range is 100V to 240 V the range 140V is 140% of the lowest voltage.
2. Description of test observation:
 - A: There was no change compared with initial operation during the test.
 - B: EUT reset automatically.



13. PHOTOS OF TESTING

- Conducted test





- Radiated test





- Harmonics test



- Voltage fluctuations test





- Electrostatic discharge immunity test



- Electrical fast transient / burst immunity test





- Radiated immunity test





-Surge test (power line)



- Inducted RF fields (conducted susceptibility) test





- Power frequency magnetic-field test



- Voltage dips, interrupts, variations test





Spectrum Research & Testing Lab., Inc.
No. 101-10, Ling 8,
Shan-Tong Li, Chung-Li
City, Taoyuan, Taiwan,
R.O.C.

TEST REPORT

Reference No.:A04052006
Report No.:EMCA04052006
Page:51 of 51
Date:May 26, 2004

14. TERMS OF ABRIVATION

AV.	Average detection
AZ(°)	Turn table azimuth
Correct.	Correction
EL(m)	Antenna height (meter)
EUT	Equipment Under Test
Horiz.	Horizontal direction
LISN	Line Impedance Stabilization Network
NSA	Normalized Site Attenuation
Q.P.	Quasi-peak detection
SRT Lab	Spectrum Research & Testing Laboratory, Inc.
Vert.	Vertical direction