



EMC COMPLIANCE TEST REPORT

for

Industrial PC

Trade Name : N/A
Model Number : PCM-6896 (N)
Serial Number : N/A
Report Number : 010449-E
Date : June 7, 2001
Regulations : See below

Standards	Results (Pass/Fail)
EN 55022: 1998(Class A)	PASS
EN 61000-3-2: 1995 + A1: 1998 + A2: 1998 + A14: 2000	PASS
EN 61000-3-3: 1995	PASS
EN 55024: 1998	PASS
- IEC 61000-4-2: 1995 + A2: 2000	PASS
- IEC 61000-4-3: 1995	PASS
- IEC 61000-4-4: 1995	PASS
- IEC 61000-4-5: 1995	PASS
- IEC 61000-4-6: 1996	PASS
- IEC 61000-4-8: 1993	N/A
- IEC 61000-4-11: 1994	PASS

Prepared for :

AAEON Technology Inc.
5F, No. 135, Lane 235, Pao Chiao Rd., Hsin-Tien City,
Taipei, Taiwan, R.O.C.

Prepared by :

C&C LABORATORY, CO., LTD.

#B1, 1st Fl., Universal Center,
No. 183, Sec. 1, Tatung Rd., Hsi Chih,
Taipei Hsien, Taiwan, R.O.C.

TEL: (02)8642-1150

FAX: (02)8642-2256



This report shall not be reproduced, except in full, without the written approval of

C&C Laboratory Co., Ltd.



EC-Declaration of Conformity

For the following equipment:

Industrial PC

(Product Name)

PCM-6896 (N)

(Model Designation / Trade name)

AAEON Technology Inc.

(Manufacturer Name)

5F, No. 135, Lane 235, Pao Chiao Rd., Hsin-Tien City, Taipei, Taiwan, R.O.C.

(Manufacturer Address)

is herewith confirmed to comply with the requirements set out in the Council Directive on the Approximation of the Laws of the Member States relating to Electromagnetic Compatibility Directive (89/336/EEC, Amended by 92/31/EEC, 93/68/EEC & 98/13/EC), For the evaluation regarding the Electromagnetic Compatibility (89/336/EEC, Amended by 92/31/EEC, 93/68/EEC& 98/13/EC), the following standards are applied:

- EN 55022: 1998 (Class A)
- EN 61000-3-2: 1995 + A1: 1998 + A2: 1998 + A14: 2000
- EN 61000-3-3: 1995
- EN55024: 1998

IEC 61000-4-2: 1995 + A2: 2000; IEC 61000-4-3: 1995; IEC 61000-4-4: 1995;
IEC 61000-4-5: 1995; IEC 61000-4-6: 1996; IEC 61000-4-11: 1994

The following manufacturer / importer or authorized representative established within the EUT is responsible for this declaration:

(Company Name)

(Company Address)

Person responsible for making this declaration:

(Name, Surname)

(Position / Title)

(Place)

Accredited Lab. of NEMKO, A2LA, BSMI
Listed Lab. of FCC, VCCI, MOC

(Date)

A2LA Certificate #: 824.01 (for Emission)
NEMKO Authorization #: ELA 124 (for EMC)

(Legal Signature)

Page 2

Rev. 00



TABLE OF CONTENTS

DESCRIPTION	PAGE
VERIFICATION OF COMPLIANCE	5
GENERAL INFORMATION	6
SYSTEM DESCRIPTION	7
PRODUCT INFORMATION	8
SUPPORT EQUIPMENT	9
TEST FACILITY	10
TEST EQUIPMENT	11
SECTION 1 EN 55022(LINE CONDUCTED & RADIATED EMISSION)	13
MEASUREMENT PROCEDURE & LIMIT (LINE CONDUCTED EMISSION TEST)	13
MEASUREMENT PROCEDURE & LIMIT (RADIATED EMISSION TEST)	16
BLOCK DIAGRAM OF TEST SETUP	19
SUMMARY DATA	20
SECTION 2 EN61000-3-2 & EN 61000-3-3 (POWER HARMONICS & VOLTAGE FLUCTUATION/FLICKER)	24
BLOCK DIAGRAM OF TEST SETUP	24
RESULT	25
SECTION 3 IEC 61000-4-2 (ELECTROSTATIC DISCHARGE)	32
BLOCK DIAGRAM OF TEST SETUP	32
TEST PROCEDURE	33
PERFORMANCE & RESULT	33
ESD TESTED POINT TO EUT	34
SECTION 4 IEC 61000-4-3 (RADIATED ELECTROM AGNETIC FIELD)	35
BLOCK DIAGRAM OF TEST SETUP	35
TEST PROCEDURE	36
PERFORMANCE & RESULT	37



DESCRIPTION	PAGE
SECTION 5 IEC 61000-4-4 (FAST TRANSIENTS/BURST)	38
BLOCK DIAGRAM OF TEST SETUP	38
TEST PROCEDURE	39
PEFORMANCE & RESULT	39
SECTION 6 IEC 61000-4-5 (SURGE IMMUNITY)	40
BLOCK DIAGRAM OF TEST SETUP	40
TEST PROCEDURE	41
PEFORMANCE & RESULT	41
SECTION 7 IEC 61000-4-6 (CONDUCTED DISTURBANCE, INDUCED BY RADIO-FREQUENCY FIELDS)	42
BLOCK DIAGRAM OF TEST SETUP	42
TEST PROCEDURE	43
PEFORMANCE & RESULT	43
SECTION 8 IEC 61000-4-8 (POWER FREQUENCY MAGNETIC FIELD)	44
BLOCK DIAGRAM OF TEST SETUP	44
TEST PROCEDURE	45
PEFORMANCE & RESULT	45
SECTION 9 IEC 61000-4-11 (VOLTAGE DIP/INTERRUPTION)	46
BLOCK DIAGRAM OF TEST SETUP	46
TEST PROCEDURE	47
PEFORMANCE & RESULT	47
APPENDIX 1 PHOTOGRAPHS OF TEST SETUP	48
EN 55022 TEST	
EN 61000-3-2 TEST	
EN 61000-3-3 TEST	
IEC 61000-4-2 Test	
IEC 61000-4-3 Test	
IEC 61000-4-4 TEST	
IEC 61000-4-5 TEST	
IEC 61000-4-6 TEST	
IEC 61000-4-11 TEST	
APPENDIX 2 PHOTOGRAPHS OF EUT	59



VERIFICATION OF COMPLIANCE

Equipment Under Test: Industrial PC
Trade Name: N/A
Model Number: PCM-6896 (N)
Serial Number: N/A
Applicant: **AAEON Technology Inc.**
5F, No. 135, Lane 235, Pao Chiao Rd., Hsin-Tien City,
Taipei, Taiwan, R.O.C.
Manufacturer: **AAEON Technology Inc.**
5F, No. 135, Lane 235, Pao Chiao Rd., Hsin-Tien City,
Taipei, Taiwan, R.O.C.
Type of Test: EMC Directive 89/336/EEC for CE Marking
Technical Standards: EN 55022: 1998 (Class A)
EN 61000-3-2: 1995 + A1: 1998 + A2: 1998 + A14: 2000,
EN 61000-3-3: 1995
EN 55024: 1998 (IEC 61000-4-2: 1995 + A2: 2000, IEC 61000-4-3: 1995,
IEC 61000-4-4: 1995, IEC 61000-4-5: 1995,
IEC 61000-4-6: 1996, IEC 61000-4-11: 1994)
File Number: 010449-E
Date of test: May 26 ~ June 2, 2001
Deviation: According to applicant's declaration this EUT is a class A product, and to be
market in industrial environment only.
Condition of Test Sample: Normal

The above equipment was tested by C&C Laboratory Co., Ltd. for compliance with the requirements set forth in EMC Directive 89/336/EEC and the Technical Standards mentioned above. This said equipment in the configuration described in this report shows the maximum emission levels emanating from equipment and the level of the immunity endurance of the equipment are within the compliance requirements.

The test results of this report relate only to the tested sample identified in this report.

Kurt Chen

Approved by Authorized Signatory: _____

Kurt Chen / Q.A. Manager

GENERAL INFORMATION

Applicant: **AAEON Technology Inc.**
5F, No. 135, Lane 235, Pao Chiao Rd., Hsin-Tien City,
Taipei, Taiwan, R.O.C.

Contact Person: Milo Wang

Manufacturer: **AAEON Technology Inc.**
5F, No. 135, Lane 235, Pao Chiao Rd., Hsin-Tien City,
Taipei, Taiwan, R.O.C.

File Number: 010449-E

Date of Test: May 26 ~ June 2, 2001

Equipment Under Test: Industrial PC

Model Number: PCM-6896 (N)

Serial Number: N/A

Technical Standards: EN 55022: 1998 (Class A)
EN 61000-3-2: 1995 + A1: 1998 + A2: 1998 + A14: 2000,
EN 61000-3-3: 1995
EN 55024: 1998 (IEC 61000-4-2: 1995 + A2: 2000, IEC 61000-4-3: 1995,
IEC 61000-4-4: 1995, IEC 61000-4-5: 1995,
IEC 61000-4-6: 1996, IEC 61000-4-11: 1994)

**Frequency Range
(EN 55022):** 150kHz to 30MHz for Line Conducted Test
30MHz to 1000MHz for Radiated Emission Test

Test Site **C&C LABORATORY CO., LTD.**
No. 81-1, 210 Lane, Pa-de 2nd Road, Lu-Chu Hsiang
Taoyuan, Taiwan, R. O. C.



SYSTEM DESCRIPTION

EUT Test Program:

1. An EMI test software was loaded and executed Windows mode.
2. A communicated software was loaded and executed to communicate between EUT and remote side.
3. EUT (Industrial PC) sends and receives data from Notebook PC on remote side via LAN cable.
4. Data was sent to Monitor filling the screen with upper case of "H" patterns.
5. Test program sequentially exercised all related I/O's of EUT and sent "H" patterns to all applicable output ports of EUT.
6. Repeat 3 to 5 Test program is self-repeating throughout the test.



PRODUCT INFORMATION

Housing Type:	Metal case	
EUT Power Rating:	100-127/ 200-240VAC, 60/ 50Hz, 5/ 2.5 5A	
AC Power during Test	230VAC/50Hz	
Power Supply Manufacturer:	CEMACS	
Power Supply Model Number:	ENP-1815	
AC Power Cord Type:	Unshielded, 1.8m (Detachable)	
DC Power Cable Type:	N/A	
CPU Manufacture:	Intel	Type: Pentium III-933MHz
OSC/Clock Frequencies:	14.318MHz, 133MHz	
Memory Capacity:		Install: 64MB
FDD Manufacturer:	TEAC	Model: FD-05HG
HDD Manufacturer:	Maxtor	Model: 33073U4
CD-ROM Manufacturer:	VINTECH	Model: VIN-S24A
Chassis Manufacturer:	AAEON	Model: AEC-6200
VGA Card Manufacturer:	On Board	
IDE Conversion Board Manufacturer:	AAEON	Model: AEC-6100 PCM-3533 ACE-6200

I/O Port of EUT

I/O PORT TYPES	Q'TY	TESTED WITH
1) Parallel Port	1	1
2) Serial Port	4	4
3) Video Port	1	1
4) PS/2 Keyboard Port	1	1
5) PS/2 Mouse Port	1	1
6) Microphone Port	1	1
7) LINE-IN Port	1	1
8) LINE-OUT Port	1	1
9) LAN Port	1	1
10) USB Port	4	4



SUPPORT EQUIPMENT

No.	Equipment	Model #	Serial #	FCC ID	Trade Name	Data Cable	Power Cord
1.	Monitor	D2827A	KR92316215	C5F7NFCMC1518X	HP	Shielded, 1.2m with a core	Unshielded, 1.8m
2.	Printer	2225C	2707S40415	DSI6XU2225	HP	Shielded, 1.4m	AC I/P: Unshielded, 1m DC O/P: Unshielded, 1m
3.	Modem	2400	94-364-176281	DK467GSM24	Computer Peripherals	Unshielded, 1.5m	Unshielded, 1.5m
4.	Modem	2400	94-364-176284	DK467GSM24	Computer Peripherals	Unshielded, 1.5m	Unshielded, 1.5m
5.	PS/2 Mouse	M-S43	LZA93406235	DZL211106	Logitech	Shielded, 1.8m	N/A
6.	PS/2 Keyboard	7932M	G91400266	E5XKB7932MUF03 10	BTC	Shielded, 1.8m	N/A
7.	USB Keyboard	5201	N/A	N/A	LEMEL	Shielded, 1.8m	N/A
8.	USB Keyboard	FDA-4251	FDKB84100149	DoC	WINIC	Shielded, 1.4m	N/A
9.	Mouse	M-MM43	LZE93353024	DoC	Logitech	Shielded, 1.9m	N/A
10.	Mouse	M-MM43	LZE93353074	DoC	Logitech	Shielded, 1.9m	N/A
11.	USB Mouse	M-BB48	LZE1450904	FCC DoC	Logitech	Shielded, 1.8m	N/A
12.	USB Mouse	M-BB48	LZE93050164	FCC DoC	Logitech	Shielded, 1.8m	N/A
13.	Walkman	YX-328	W7	N/A	YING-KO	Unshielded, 1.8m	N/A
14.	Multimedia Headset	SX-M	A5-5	N/A	TOKYO	Unshielded, 1.8m	N/A
15.	Notebook PC (Remote)	VALIANT6380 IPTD	N/A	N/A	KDS	LAN Cable: Unshielded, 15m	AC I/P: Unshielded, 1.8m DC O/P: Unshielded, 1.8m

Note: All the above equipment/cables were placed in worse case positions to maximize emission signals during emission test.

Grounding: Grounding was in accordance with the manufacturer's requirements and conditions for the intended use.



TEST FACILITY

- Location:** No. 15, 14 Line, Chin Twu Chi, Lu Chu Hsiang, Taoyuan, Taiwan, R.O.C.
- Description:** There are Four 3/10m open area test sites and three line conducted labs for final test The Open Area Test Sites and the Line Conducted labs are constructed and calibrated to meet the FCC requirements in documents
ANSI C63.4: 1992 and CISPR 22/EN 55022 requirements.
- Site Filing:** A site description is on file with the Federal Communications Commission, 7435 Oakland Mills Road, Columbia, MD 21046.

Registration also was made with Voluntary Control Council for Interference (VCCI).
- Site Accreditation:** Accredited by NEMKO (Authorization #: ELA 124) for EMC & A2LA (Certificate #: 824.01) for Emission

Also accredited by BSMI for the product category of Information Technology Equipment.
- Instrument Tolerance:** All measuring equipment is in accord with ANSI C63.4 and CISPR 22 requirements that meet industry regulatory agency and accreditation agency requirement.
- Ground Plane:** Two conductive reference ground planes were used during the Line Conducted Emission, one in vertical and the other in horizontal. The dimensions of these ground planes are as below. The vertical ground plane was placed distancing 40 cm to the rear of the wooden test table on where the EUT and the support equipment were placed during test. The horizontal ground plane projected 50 cm beyond the footprint of the EUT system and distanced 80 cm to the wooden test table. For Radiated Emission Test, one horizontal conductive ground plane extended at least 1m beyond the periphery of the EUT and the largest measuring antenna, and covered the entire area between the EUT and the antenna. It has no holes or gaps having longitudinal dimensions larger than one-tenth of a wavelength at the highest frequency of measurement up to 1GHz.

Site # 3 & # 4 Line Conducted Test Site: At Shielding Room



TEST EQUIPMENT LIST

Instrumentation: The following list contains equipment used at C & C Laboratory, Co., Ltd. for testing. The equipment conforms to the CISPR 16-1 / ANSI C63.2-1988 Specifications for Electromagnetic Interference and Field Strength Instrumentation from 10kHz to 1.0 / 2.0 GHz.

Equipment used during the tests:

Open Area Test Site: # 4

Open Area Test Site # 4					
EQUIPMENT TYPE	MFR	MODEL NUMBER	SERIAL NUMBER	LAST CAL.	CAL. DUE
Spectrum Analyzer	ADVANTEST	R3132	91700456	02/21/2001	02/20/2002
EMI Test Receiver	R&S	ESVS10	846285/016	04/16/2001	04/15/2002
Precision Dipole	R&S	HZ-12	846932/0004	07/14/2000	07/13/2001
Precision Dipole	R&S	HZ-13	846556/0008	07/14/2000	07/13/2001
Bilog Antenna	CHASE	CBL 6112B	2462	01/16/2001	01/15/2002
Turn Table	Chance most	N/A	N/A	N.C.R	N.C.R
Antenna Tower	Chance most	N/A	N/A	N.C.R	N.C.R
Controller	Chance most	N/A	N/A	N.C.R	N.C.R
RF Switch	ANRITSU	MP59B	M51067	N.C.R	N.C.R
Site NSA	C&C Lab.	N/A	N/A	11/24/2000	11/23/2001

Conducted Emission Test Site: # 4

Conducted Emission Test Site # 4					
EQUIPMENT TYPE	MFR	MODEL NUMBER	SERIAL NUMBER	LAST CAL.	CAL. DUE
EMI Test Receiver	R&S	ESHS10	843743/015	12/15/2000	12/14/2001
LISN	R&S	ENV 4200	8303261016	11/18/2000	11/17/2001
LISN	EMCO	3825/2	9003/1382	02/08/2001	02/07/2002
2X2 WIRE ISN	R&S	ENY22	830661/027	04/06/2001	04/05/2002
FOUR WIRE ISN	R&S	ENY41	830663/024	04/04/2001	04/03/2002

Conducted Emission Test Site: # 3

Conducted Emission Test Site # 3					
EQUIPMENT TYPE	MFR	MODEL NUMBER	SERIAL NUMBER	LAST CAL.	CAL. DUE
EMI Test Receiver	R&S	ESCS30	847793/012	11/10/2000	11/09/2001
LISN	EMCO	3825/2	9003-1628	07/12/2000	07/11/2001
LISN	R&S	ESH2-Z5	843285/010	12/12/2000	12/11/2001

The calibrations of the measuring instruments, including any accessories that may effect such calibration, are checked frequently to assure their accuracy. Adjustments are made and correction factors applied in accordance with instructions contained in the manual for the measuring instrument.



TEST EQUIPMENT LIST

For Power Harmonic & Voltage Fluctuation/Flicker Measurement:

Manufacturer/Type	Model No.	Serial No.	Last Cal.	Cal. Due
HAEFELY TRENCH Harmonic & Flicker Tester	PHF 555	080 419-25	Oct. 16, 2000	Oct. 15, 2001

For ESD test:

Manufacturer/Type	Model No.	Serial No.	Last Cal.	Cal. Due
HAEFELY/TRENCH ESD Generator	PESD 1600	H710203	Sep. 02, 2000	Sep. 01, 2001

For Radiated Electromagnetic Field immunity Measurement:

Manufacturer/Type	Model No.	Serial No.	Last Cal.	Cal. Due
Maconi /Signal Generator	2022D	119246/003	Aug. 21, 2000	Aug. 20, 2001
M2S / Power Amplifier	A00181/1000	9801-112	N/A	N/A
M2S / Power Amplifier	AC8113/800-250A	9801-179	N/A	N/A
Wandel & Goltormann/ EM-Radiation Meter	EMR-30	L-0013	Mar. 16, 2001	Mar. 15, 2002
EMCO Power Antenna	93141	9712-1083	N/A	N/A

For Fast Transients/Burst test:

Manufacturer/Type	Model No.	Serial No.	Last Cal.	Cal. Due
HAEFELY TRENCH/ Fast Transients/Burst Generator	PEFT-JUNIOR	583 333-117	Aug. 21, 2000	Aug. 20, 2001
HAEFELY TRENCH/ Clamp	093 506.1	080 421.13	N/A	N/A

For CS test:

Manufacturer/Type	Model No.	Serial No.	Last Cal.	Cal. Due
Maconi /Signal Generator	2022D	119246/003	Aug. 21, 2000	Aug. 20, 2001
MEB / CDN M3	M3	3683	Sep. 11, 2000	Sep. 10, 2001
C.D.N / CDN M2	CDN-M2	A3002010	Apr. 17, 2001	Apr. 16, 2002
M2S / Power Amplifier	A00181/1000	9801-112	N/A	N/A
MEB / Clamp	KEMZ-801	13 602	N/A	N/A

For Surge Immunity test:

Manufacturer/Type	Model No.	Serial No.	Last Cal.	Cal. Due
HAEFELY TRENCH/ Surge Tester	PSURGE 4010	583 334-71	Sep. 01, 2000	Aug. 31, 2001
HAEFELY TRENCH/ CDN	IP6.2	148342	Mar. 22, 2001	Mar. 21, 2002
HAEFELY TRENCH/ CDN	DEC1A	148050	Apr. 06, 2001	Apr. 05, 2002

For Power Frequency Magnetic Field Immunity test:

Manufacturer/Type	Model No.	Serial No.	Last Cal.	Cal. Due
F.W.BELL/ TRIAX ELF Magnetic Field Meter	4090	9711	Oct, 20,2000	Oct.19, 2001
HAEFELY TRENCH/ Magnetic Field Tester	MAG 100.1	080 938-01	N/A	N/A

For Voltage Dips/Short Interruption and Voltage Variation Immunity test:

Manufacturer/Type	Model No.	Serial No.	Last Cal.	Cal. Due
HAEFELY TRENCH/ Dips/Interruption and Variations Simulator	PLINE 1610	080 344-05	Feb. 08, 2001	Feb. 07, 2002



SECTION 1 EN 55022 (LINE CONDUCTED & RADIATED EMISSION)

MEASUREMENT PROCEDURE (PRELIMINARY LINE CONDUCTED EMISSION TEST)

- 1) The equipment was set up as per the test configuration to simulate typical actual usage per the user's manual. When the EUT is a tabletop system, a wooden table with a height of 0.8 meters is used and is placed on the ground plane as per EN 55022 (see Test Facility for the dimensions of the ground plane used). When the EUT is a floor-standing equipment, it is placed on the ground plane which has a 3-12 mm non-conductive covering to insulate the EUT from the ground plane.
- 2) Support equipment, if needed, was placed as per EN 55022.
- 3) All I/O cables were positioned to simulate typical actual usage as per EN 55022.
- 4) The EUT received AC power through a Line Impedance Stabilization Network (LISN) which supplied power source and was grounded to the ground plane.
- 5) All support equipment received power from a second LISN supplying power of 110VAC/60Hz.
- 6) The EUT test program was started. Emissions were measured on each current carrying line of the EUT using a spectrum Analyzer / Receiver connected to the LISN powering the EUT. The LISN has two monitoring points: Line 1 (Hot Side) and Line 2 (Neutral Side). Two scans were taken: one with Line 1 connected to Analyzer / Receiver and Line 2 connected to a 50 ohm load; the second scan had Line 1 connected to a 50 ohm load and Line 2 connected to the Analyzer / Receiver.
- 7) Analyzer / Receiver scanned from 150kHz to 30MHz for emissions in each of the test modes.
- 8) During the above scans, the emissions were maximized by cable manipulation.
- 9) The following test mode(s) were scanned during the preliminary test:

Mode(s): (Customer defined)

1. 1024 x 768 x 256 Colors Resolution

- 10) After the preliminary scan, we found the following test mode producing the highest emission level.

Mode: 1.

Then, the EUT configuration and cable configuration of the above highest emission level were recorded for reference of final testing.



MEASUREMENT PROCEDURE (FINAL LINE CONDUCTED EMISSION TEST)

- 1) EUT and support equipment was set up on the test bench as per step 10 of the preliminary test.
- 2) A scan was taken on both power lines, Line 1 and Line 2, recording at least the six highest emissions. Emission frequency and amplitude were recorded into a computer in which correction factors were used to calculate the emission level and compare reading to the applicable limit.
- 3) The test data of the worst case condition(s) was reported on the Summary Data page.

Data Sample:

Freq. MHz	Q.P. Raw dBuV	Average Raw dBuV	Q.P. Limit dBuV	Average Limit dBuV	Q.P. Margin dB	Average Margin dB	Note
x.xx	43.95	---	56	46	-12.05	-2.05	L 1

Freq.	= Emission frequency in MHz
Raw dBuV	= Uncorrected Analyzer/Receiver reading
Limit dBuV	= Limit stated in standard
Margin dB	= Reading in reference to limit
Note	= Current carrying line of reading
“---“	= The emission level complied with the Average limits, with at least 2 dB margin, so no further recheck.

LINE CONDUCTED EMISSION LIMIT

Frequency	Maximum RF Line Voltage	
	Q.P.	AVERAGE
150kHz-500kHz	79dBuV	66dBuV
500kHz-5MHz	73dBuV	60dBuV
5MHz-30MHz	73dBuV	60dBuV

Note: The lower limit shall apply at the transition frequency.



MEASUREMENT PROCEDURE (COMMON MODE CONDUCTED EMISSION MEASUREMENT)

- 1) Selecting ISN for unscreened cable or a current probe for screened cable to take measurement.
- 2) The port of the EUT was connected to the remote side support equipment through the ISN/Current Probe and communication in normal condition.
- 3) Making a overall range scan by using the test receiver controlled by controller and record at least six highest emissions for showing in the test report.
- 4) Emission frequency and amplitude were recorded into a computer in which correction factors were used to calculate the emission level and compare reading to the applicable limit.
- 5) In case of measuring on the screened cable, the current limit shall be applied, otherwise the voltage limit be applied.
- 6) The test data of the worst case condition(s) was reported on the Summary Data page.

Data Sample:

Freq. MHz	Q.P. Raw dBuV	Average Raw dBuV	Q.P. Limit dBuV	Average Limit dBuV	Q.P. Margin dB	Average Margin dB	Note
x.xx	43.95	---	87	74	-43.05	---	

- | | |
|------------|--|
| Freq. | = Emission frequency in MHz |
| Raw dBuV | = Uncorrected Analyzer / Receiver reading |
| Limit dBuV | = Limit stated in standard |
| Margin dB | = Reading in reference to limit |
| Note | = Current carrying line of reading |
| “---“ | = The emission level complied with the Average limits, with at least 2 dB margin, so no further recheck. |

COMMON MODE CONDUCTED EMISSION LIMIT AT TELECOMMUNICATION PORTS

<input checked="" type="checkbox"/> CE-Mark (EN 55022:1998)					
CLASS	Measuring Band	Voltage limit dB(uV)		Current limit dB(uA)	
		Q.P.	AV	Q.P.	AV
A	150kHz-500kHz	97-87	84-74	53-43	40-30
	500kHz-30MHz	87	74	43	30

Note: The lower limit shall apply at the transition frequency.

MEASUREMENT PROCEDURE (PRELIMINARY RADIATED EMISSION TEST)

- 1) The equipment was set up as per the test configuration to simulate typical actual usage per the user's manual. When the EUT is a tabletop system, a wooden turntable with a height of 0.8 meters is used which is placed on the ground plane as per EN 55022 (see Test Facility for the dimensions of the ground plane used). When the EUT is a floor-standing equipment, it is placed on the ground plane which has a 3-12 mm non-conductive covering to insulate the EUT from the ground plane.
- 2) Support equipment, if needed, was placed as per EN 55022.
- 3) All I/O cables were positioned to simulate typical actual usage as per EN 55022.
- 4) The EUT received AC power source from the outlet socket under the turntable. All support equipment received 110VAC/60Hz power from another socket under the turntable.
- 5) The antenna was placed at some given distance away from the EUT as stated in EN 55022. The antenna connected to the analyzer via a cable and at times a pre-amplifier would be used.
- 6) The Analyzer quickly scanned from 30MHz to 1000MHz. The EUT test program was started. Emissions were scanned and measured rotating the EUT to 360 degrees and positioning the antenna 1 to 4 meters above the ground plane, in both the vertical and the horizontal polarization, to maximize the emission reading level.
- 7) The following test mode(s) were scanned during the preliminary test:

Mode(s): (Customer defined)

1. **1024 x 768 x 256 Colors Resolution**

- 8) After the preliminary scan, we found the following test mode producing the highest emission level.

Mode: 1.

Then, the EUT and cable configuration, antenna position, polarization and turntable position of the above highest emission level were recorded for final testing.



MEASUREMENT PROCEDURE (FINAL RADIATED EMISSION TEST)

- 1) EUT and support equipment were set up on the turntable as per step 8 of the preliminary test.
- 2) The Analyzer / Receiver scanned from 30MHz to 1000MHz. Emissions were scanned and measured rotating the EUT to 360 degrees, varying cable placement and positioning the antenna 1 to 4 meters above the ground plane, in both the vertical and the horizontal polarization, to maximize the emission reading level.
- 3) Recorded at least the six highest emissions. Emission frequency, amplitude, antenna position, polarization and turntable position were recorded into a computer in which correction factors were used to calculate the emission level and compare reading to the applicable limit and only Q.P. reading is presented.
- 4) The test data of the worst case condition(s) was reported on the Summary Data page.

Data Sample:

Freq. (MHz)	Raw Data (dBuV/m)	Corr. Factor (dB)	Emiss. Level (dBuV/m)	Limits	Margin (dB)
xx.xx	14.0	11.2	26.2	30	-3.8

Freq.	= Emission frequency in MHz
Raw Data (dBuV/m)	= Uncorrected Analyzer / Receiver reading
Corr. Factor (dB)	= Correction factors of antenna factor and cable loss
Emiss. Level	= Raw reading converted to dBuV and CF added
Limit dBuV/m	= Limit stated in standard
Margin dB	= Reading in reference to limit



RADIATED EMISSION LIMIT

Frequency (MHz)	Distance (m)	Maximum Field Strength Limit (dBuV/m/ Q.P.)
30-230	10	40
230-1000	10	47

Note: The lower limit shall apply at the transition frequency.

BLOCK DIAGRAM OF TEST SETUP

SYSTEM DIAGRAM OF CONNECTIONS BETWEEN EUT AND SIMULATORS

EUT: Industrial PC

Trade Name: N/A

Model Number: PCM-6896 (N)

Power Cord: Unshielded, 1.8m

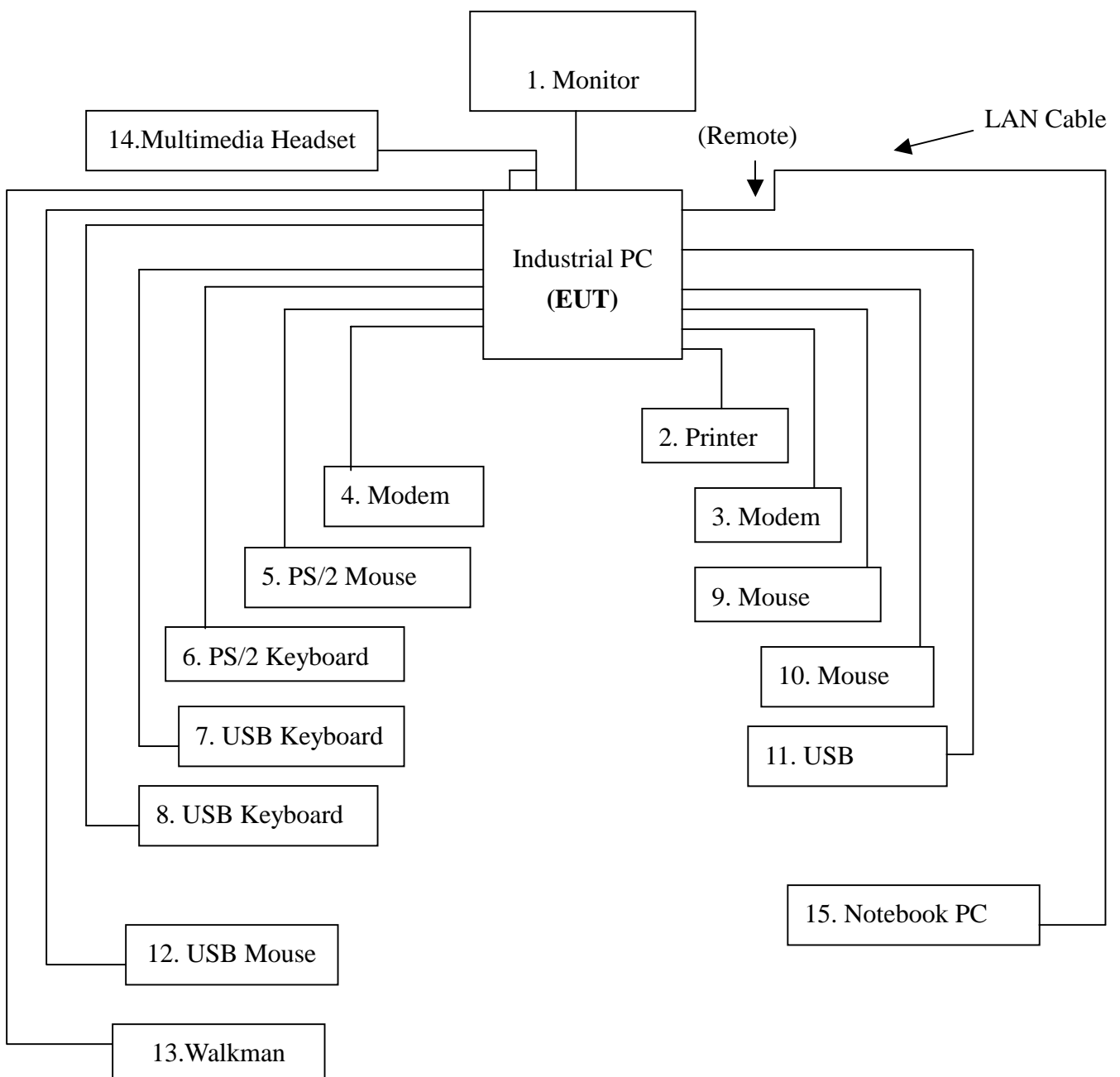



SUMMARY DATA

(COMMON Mode)

(LAN Port)

Model Number: PCM-6896 (N)

Location: Site # 4

Tested by: Boss Yu

Test Mode: Mode 1

Test Results: Passed

Temperature: 24°C

Humidity: 68%RH

(The chart below shows the highest readings taken from the final data)

FREQ MHz	Q.P. Raw dBuV	AVG Raw dBuV	Q.P. Limit dBuV	AVG Limit dBuV	Q.P. Margin dB	AVG Margin dB	NOTE
0.150	58.3	---	97.0	84.0	-38.7	---	10Base
1.930	39.8	---	87.0	74.0	-47.2	---	10Base
2.900	39.9	---	87.0	74.0	-47.1	---	10Base
4.240	41.3	---	87.0	74.0	-45.7	---	10Base
5.690	39.8	---	87.0	74.0	-47.2	---	10Base
26.880	36.4	---	87.0	74.0	-50.6	---	10Base
16.230	58.3	---	87.0	74.0	-28.7	---	100Base
18.200	56.3	---	87.0	74.0	-30.7	---	100Base
19.710	56.8	---	87.0	74.0	-30.2	---	100Base
21.660	56.7	---	87.0	74.0	-30.3	---	100Base
23.130	59.8	---	87.0	74.0	-27.2	---	100Base
24.350	56.3	---	87.0	74.0	-30.7	---	100Base

L1 = Line One (Hot side) / L2 = Line Two (Neutral side)

****NOTE: “---” denotes the emission level was or more than 2dB below the Average limit,
 so no re-check anymore.**



SUMMARY DATA

(LINE CONDUCTED TEST)

Model Number: PCM-6896 (N)

Location: Site # 3

Tested by: Boss Yu

Test Mode: Mode 1

Test Results: Passed

Temperature: 24°C

Humidity: 68%RH

(The chart below shows the highest readings taken from the final data)

FREQ MHz	Q.P. RAW dBuV	AVG RAW dBuV	Q.P. Limit dBuV	AVG Limit dBuV	Q.P. Margin dB	AVG Margin dB	NOTE
16.930	52.1	---	73.00	60.00	-20.9	---	L1
19.000	33.9	---	73.00	60.00	-39.1	---	L1
19.770	31.4	---	73.00	60.00	-41.6	---	L1
21.160	36.4	---	73.00	60.00	-36.6	---	L1
25.380	45.3	---	73.00	60.00	-27.7	---	L1
25.410	45.1	---	73.00	60.00	-27.9	---	L1
0.150	31.4	---	79.00	66.00	-47.6	---	L2
16.860	49.4	---	73.00	60.00	-23.6	---	L2
21.080	33.8	---	73.00	60.00	-39.2	---	L2
25.260	40.3	---	73.00	60.00	-32.7	---	L2
26.100	26.9	---	73.00	60.00	-46.1	---	L2
27.130	27.2	---	73.00	60.00	-45.8	---	L2

L1 = Line One (Hot side) / L2 = Line Two (Neutral side)

****NOTE: “---” denotes the emission level was or more than 2dB below the Average limit, so no re-check anymore.**



SUMMARY DATA

(RADIATED EMISSION TEST)

Model Number: PCM-6896 (N) **Location:** Site # 4
Tested by: Boss Yu
Test Mode: Mode 1 **Polar:** Vertical -- 10m
Detector Function: Quasi-Peak **Test Results:** Passed
Temperature: 24°C **Humidity:** 58%RH

(The chart below shows the highest readings taken from the final data)

Freq. (MHz)	Raw Data (dBuV/m)	Corr. Factor (dB)	Emiss. Level (dBuV/m)	Limits	Margin (dB)
75.59	15.5	7.3	22.8	40.0	-17.2
120.21	12.8	13.0	25.8	40.0	-14.2
401.51	10.0	18.8	28.8	47.0	-18.2
501.42	9.4	20.7	30.1	47.0	-16.9
532.46	9.1	21.2	30.3	47.0	-16.7
665.35	9.3	21.9	31.2	47.0	-15.8



SUMMARY DATA

(RADIATED EMISSION TEST)

Model Number: PCM-6896 (N)

Location: Site # 4

Tested by: Boss Yu

Test Mode: Mode 1

Polar: Horizontal -- 10m

Detector Function: Quasi-Peak

Test Results: Passed

Temperature: 24⁰C

Humidity: 58%RH

(The chart below shows the highest readings taken from the final data)

Freq. (MHz)	Raw Data (dBuV/m)	Corr. Factor (dB)	Emiss. Level (dBuV/m)	Limits	Margin (dB)
75.68	15.0	7.3	22.3	40.0	-17.7
120.39	10.1	13.0	23.1	40.0	-16.9
401.28	10.0	18.8	28.8	47.0	-18.2
501.39	10.2	20.7	30.9	47.0	-16.1
532.50	9.7	21.2	30.9	47.0	-16.1
665.65	10.8	21.9	32.7	47.0	-14.3

SECTION 2 EN 61000-3-2 & EN 61000-3-3 (POWER HARMONICS & VOLTAGE FLUCTUATION/FLICKER)

POWER HARMONICS MEASUREMENT

Port : AC mains
Basic Standard : EN 61000-3-2 (1995 + A1: 1998 + A2: 1998)
Limits : CLASS A ; CLASS D
Tester : Boss Yu
Temperature : 25°C
Humidity : 60%

VOLTAGE FLUCTUATION/FLICKER MEASUREMENT

Port : AC mains
Basic Standard : EN 61000-3-3 (1995)
Limits : §5 of EN 61000-3-3
Tester : Boss Yu
Temperature : 25°C
Humidity : 60%

Block Diagram of Test Setup:

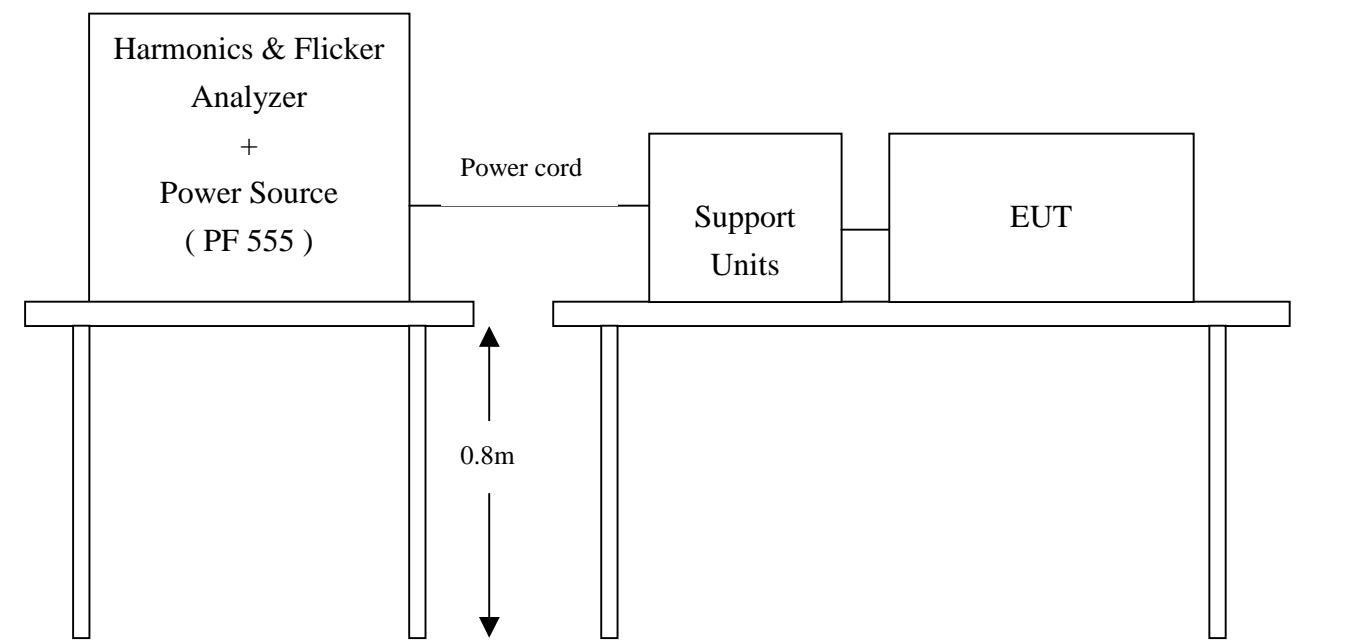

Result:

Please see the attached test data.



EN 61000-3-2 TEST REPORT 2/JUN/2001 11:46 AM

Unit: Industrial PC

Model No.: PCM-6896(N)

Remarks: TEMP:25°C HUMI:60% PRESS:1005 MBAR

Operator: BOSS
=====

TEST SETUP

Test Freq.:	50.00 Hz.	Test Voltage:	230.0 vac
Waveform :	SINE	Test Time:	2.5 min.
Classification :	CLASS A	Test Type:	STEADY-STATE

Prog. Zo Enabled: YES Prog. Zo: 0.000

Motor Driven with Phase Angle Control: NO
Impedance selected: DIRECT

Synthetic R+L Enabled: NO
Resistance: 0.380 Ohms Inductance: 460.000 uH

MAX WATT: 39.5 WATTS



TEST DATA

Result: PASS

Harmonic Current Results

0	0.000	0.000	0.000	PASS
1	0.178	NaN	NaN	PASS
2	0.004	1.080	1.080	PASS
3	0.150	2.300	2.300	PASS
4	0.003	0.430	0.430	PASS
5	0.137	1.140	1.140	PASS
6	0.002	0.300	0.300	PASS
7	0.128	0.770	0.770	PASS
8	0.002	0.230	0.230	PASS
9	0.115	0.400	0.400	PASS
10	0.001	0.184	0.184	PASS
11	0.100	0.330	0.330	PASS
12	0.001	0.153	0.153	PASS
13	0.083	0.210	0.210	PASS
14	0.001	0.131	0.131	PASS
15	0.067	0.150	0.150	PASS
16	0.001	0.115	0.115	PASS
17	0.051	0.132	0.132	PASS
18	0.001	0.102	0.102	PASS
19	0.037	0.118	0.118	PASS



20	0.001	0.092	0.092	PASS
21	0.024	0.107	0.107	PASS
22	0.001	0.084	0.084	PASS
23	0.014	0.098	0.098	PASS
24	0.001	0.077	0.077	PASS
25	0.008	0.090	0.090	PASS
26	0.001	0.071	0.071	PASS
27	0.009	0.083	0.083	PASS
28	0.001	0.066	0.066	PASS
29	0.011	0.078	0.078	PASS
30	0.001	0.061	0.061	PASS
31	0.012	0.073	0.073	PASS
32	0.001	0.058	0.058	PASS
33	0.012	0.068	0.068	PASS
34	0.000	0.054	0.054	PASS
35	0.011	0.064	0.064	PASS
36	0.001	0.051	0.051	PASS
37	0.009	0.061	0.061	PASS
38	0.001	0.048	0.048	PASS
39	0.006	0.058	0.058	PASS
40	0.001	0.046	0.046	PASS



EN 61000-3-3 TEST REPORT 2/JUN/2001 12:04 PM

Unit: Industrial PC

Model No.: PCM-6896(N) (Continue)

Remarks: TEMP:25°C HUMI:60% PRESS:1005 MBAR

Operator: BOSS

=====

TEST SETUP

Test Freq.: 50.00 Hz. Test Voltage: 230.0 vac
Waveform : SINE
Test Time: 10.0 min. Tshort: 10.0 min.
Prog. Zo Enabled: YES Prog. Zo: 0.000
Voltage Change less than once per Hour: NO
Impedance selected: DIRECT
Synthetic R+L Enabled: NO
Resistance: 0.380 Ohms Inductance: 460.000 uH



TEST DATA

Result: PASS

	EUT Data	Limit	Result	Test Enabled
Pst max	0.008	1.00	PASS	true
Plt max	0.008	0.65	PASS	true
dc %	0.00	3.00	PASS	true
dmax %	0.00	4.00	PASS	true
d(t) sec.	0.00	0.20	PASS	true

Power Source Data

Source Pst max	0.025	0.400	PASS	true
% THD	0.03	3.00	PASS	true



EN 61000-3-3 TEST REPORT 2/JUN/2001 12:28 PM

Unit: Industrial PC

Model No.: PCM-6896(N) (Manual Switch)

Remarks: TEMP:25°C HUMI:60% PRESS:1005 MBAR

Operator: BOSS

=====

TEST SETUP

Test Freq.: 50.00 Hz. Test Voltage: 230.0 vac
Waveform : SINE
Test Time: 3.0 min. Tshort: 10.0 min.

Prog. Zo Enabled: YES Prog. Zo: 0.000

Voltage Change less than once per Hour: NO
Impedance selected: DIRECT

Synthetic R+L Enabled: NO
Resistance: 0.380 Ohms Inductance: 460.000 uH



TEST DATA

Result: PASS

	EUT Data	Limit	Result	Test Enabled
Pst max	0.012	1.00	PASS	true
Plt max	0.012	0.65	PASS	true
dc %	0.00	3.00	PASS	true
dmax %	0.00	4.00	PASS	true
d(t) sec.	0.00	0.20	PASS	true

Power Source Data

Source Pst max	0.000	0.400	PASS	true
% THD	0.03	3.00	PASS	true

SECTION 3 EN 61000-4-2 (ELECTROSTATIC DISCHARGE)

ELECTROSTATIC DISCHARGE (ESD) IMMUNITY TEST

Port : Enclosure
Basic Standard : EN 61000-4-2
Requirements : $\pm 8\text{kV}$ (Air Discharge)
(Customer requested) $\pm 4\text{kV}$ (Contact Discharge)
 $\pm 4\text{kV}$ (Indirect Discharge)
Performance Criteria : B (Standard Required)
Tested by : Boss Yu
Temperature/Humidity: 25°C /60%

Block Diagram of Test Setup:

(The 470 k ohm resistors are installed per standard requirement)

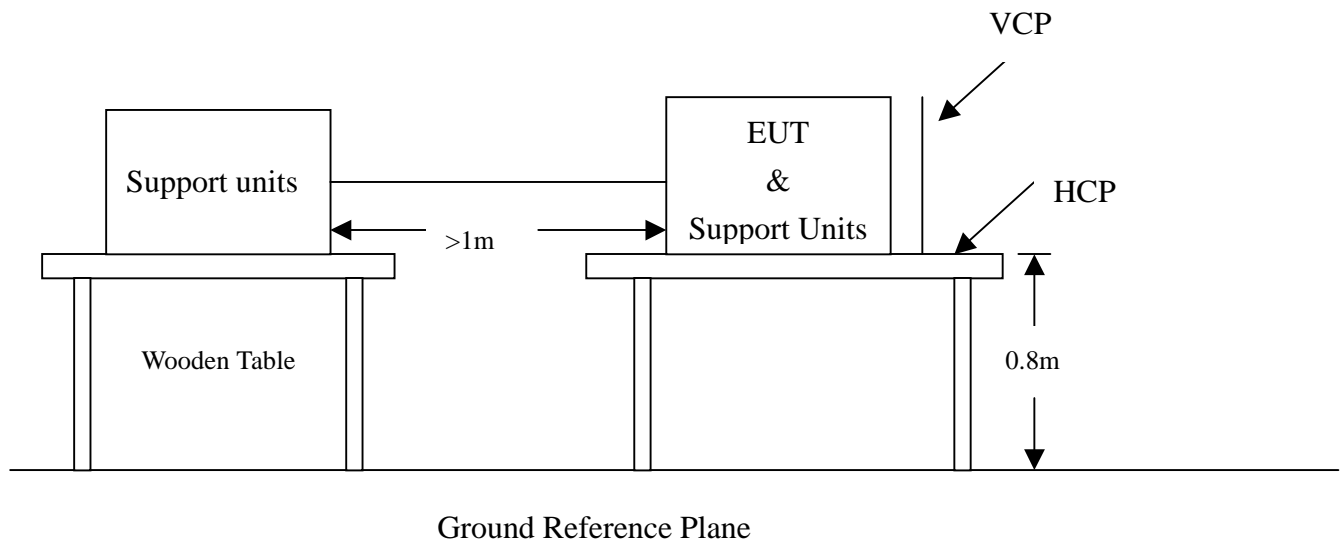



Test Procedure:

1. The EUT was located 0.1 m minimum from all side of the HCP.
2. The support units were located 1 m minimum away from the EUT.
3. A scroll 'H' test program was loaded and executed in Windows mode.
4. The EUT sent above message to EUT and related peripherals through the test.
5. Active the communication function if the EUT with such port(s).
6. As per the requirement of EN 55024; applying direct contact discharge at the sides other than front of EUT at minimum 50 discharges (25 positive and 25 negative) if applicable, can't be applied direct contact discharge side of EUT then the indirect discharge shall be applied. One of the test points shall be subjected to at least 50 indirect discharge (contact) to the front edge of horizontal coupling plane.
7. Other parts of EUT where it is not possible to perform contact discharge then selecting appropriate points of EUT for air discharge, a minimum of 10 single air discharges shall be applied.
8. The application of ESD to the contact of open connectors is not required.
9. Putting a mark on EUT to show tested points. The following test condition was followed during the tests.

Note: As Per the A2 to IEC 61000-4-2, a bleed resistor cable is connected between the EUT and HCP during the test.

The electrostatic discharges were applied as follows:

Amount of Discharges	Voltage	Coupling	Result (Pass/Fail)
Mini 10 / Point	±8kV	Air Discharge	Pass
Mini 25 / Point	±4kV	Contact Discharge	Pass
Mini 25 / Point	±4kV	Indirect Discharge HCP (Front)	Pass

**** The tested points to EUT, please refer to attached pages.
(Blue arrow mark for Contact Discharge, Red arrow mark for Air Discharge)**

Performance & Result:

- Criteria A:** The apparatus continues to operate as intended. No degradation of performance or loss of function is allowed below a performance level specified by the manufacturer, when the apparatus is used as intended. In some cases the performance level may be replaced by a permissible loss of performance.
- Criteria B:** The apparatus continues to operate as intended after the test. No degradation of performance or loss of function is allowed below a performance level specified by the manufacturer, when the apparatus is used as intended. In some cases the performance level may be replaced by a permissible loss of performance. During the test, degradation of performance is however allowed.
- Criteria C:** Temporary loss of function is allowed, provided the functions self recoverable or can be restored by the operation of controls.

PASS **FAILED**

Observation: No any function degraded during the tests.

The Tested Points of EUT

Photo 1 of 2



Photo 1 of 2



SECTION 4 IEC 61000-4-3 (RADIATED ELECTROMAGNETIC FIELD)

RADIATED ELECTROMAGNETIC FIELD IMMUNITY TEST

Port : Enclosure
Basic Standard : IEC 61000-4-3
Requirements : 3 V/m, with Modulated
Performance Criteria : A (Standard Required)
Tested by : Boss Yu
Temperature : 25⁰C
Humidity : 60%

Block Diagram of Test Setup:

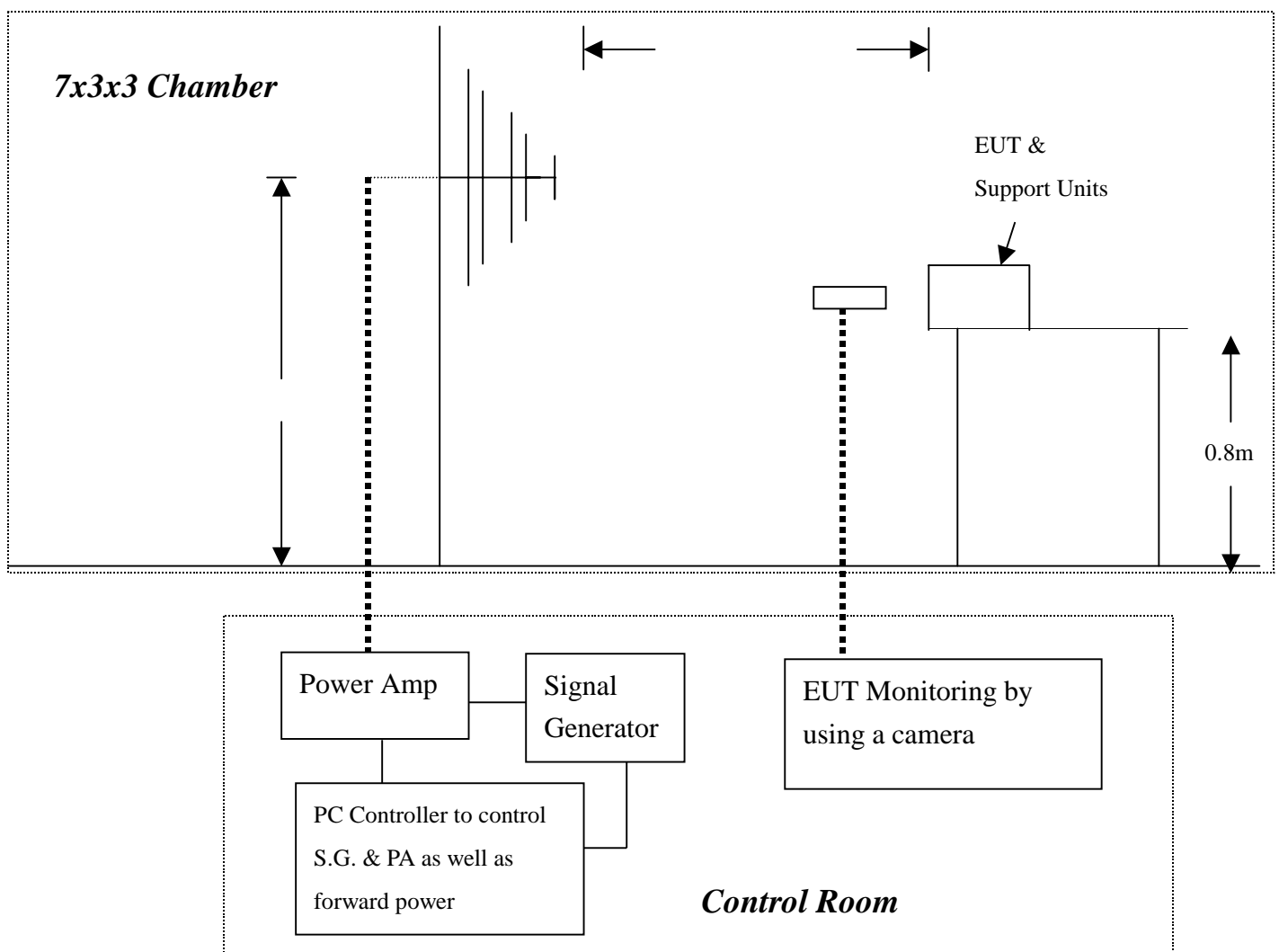



Test Procedure:

1. The EUT was located at the edge of supporting table keep 3 meter away from transmitting antenna, it just the calibrated square area of field uniformity. The support units were located outside of the uniformity area, but the cable(s) connected with EUT were exposed to the calibrated field as per IEC 61000-4-3.
2. A scroll 'H' messages were displayed on part of screen of EUT and an enlarged 'H' characters were displayed on the other part of screen of EUT.
3. Adjusting the monitoring camera to monitor the 'H' message as clear as possible.
4. Setting the testing parameters of RS test software per IEC 61000-4-3.
5. Performing the pre-test at each side of with double specified level (6V/m) at 4% steps.
6. From the result of pre-test in step 5, choice the worst side of EUT for final test from 80 MHz to 1000 MHz at 1% steps.
7. Recording the test result in following table.
8. It is not necessary to perform test as per annex A of EN 55024:1998 if the EUT doesn't belong to TTE product.

Preliminary test conditions:

Test level : 6V/m
Steps : 4 % of fundamental;
Dwell Time : 3 sec

Range (MHz)	Field	Modulation	Polarity	Position (°)	Result (Pass/Fail)
80-1000	6V	Yes	H	Front	Pass
80-1000	6V	Yes	V	Front	Pass
80-1000	6V	Yes	H	Right	Pass
80-1000	6V	Yes	V	Right	Pass
80-1000	6V	Yes	H	Back	Pass
80-1000	6V	Yes	V	Back	Pass
80-1000	6V	Yes	H	Left	Pass
80-1000	6V	Yes	V	Left	Pass

Final test conditions:

Test level : 3V/m
Steps : 1 % of fundamental;
Dwell Time : 3 sec

Range (MHz)	Field	Modulation	Polarity	Position (°)	Result (Pass/Fail)
80-1000	3V	Yes	H	Back	Pass
80-1000	3V	Yes	V	Back	Pass



Performance & Result:

- Criteria A:** The apparatus continues to operate as intended. No degradation of performance or loss of function is allowed below a performance level specified by the manufacturer, when the apparatus is used as intended. In some cases the performance level may be replaced by a permissible loss of performance.

- Criteria B:** The apparatus continues to operate as intended after the test. No degradation of performance or loss of function is allowed below a performance level specified by the manufacturer, when the apparatus is used as intended. In some cases the performance level may be replaced by a permissible loss of performance. During the test, degradation of performance is however allowed.

- Criteria C:** Temporary loss of function is allowed, provided the functions self-recoverable or can be restored by the operation of controls.

PASS **FAILED**

Observation: No any function degraded during the tests.

SECTION 5 IEC 61000-4-4 (FAST TRANSIENTS/BURST)

FAST TRANSIENTS/BURST IMMUNITY TEST

Port	: On Power Supply Lines and Data Cable
Basic Standard	: IEC 61000-4-4
Requirements	: $\pm 1\text{kV}$ for Power Supply Line $\pm 0.5\text{kV}$ for Data Cable
Performance Criteria	: B (Standard require)
Tested by	: Boss Yu
Temperature	: 25°C
Humidity	: 60%

Block Diagram of Test Setup:

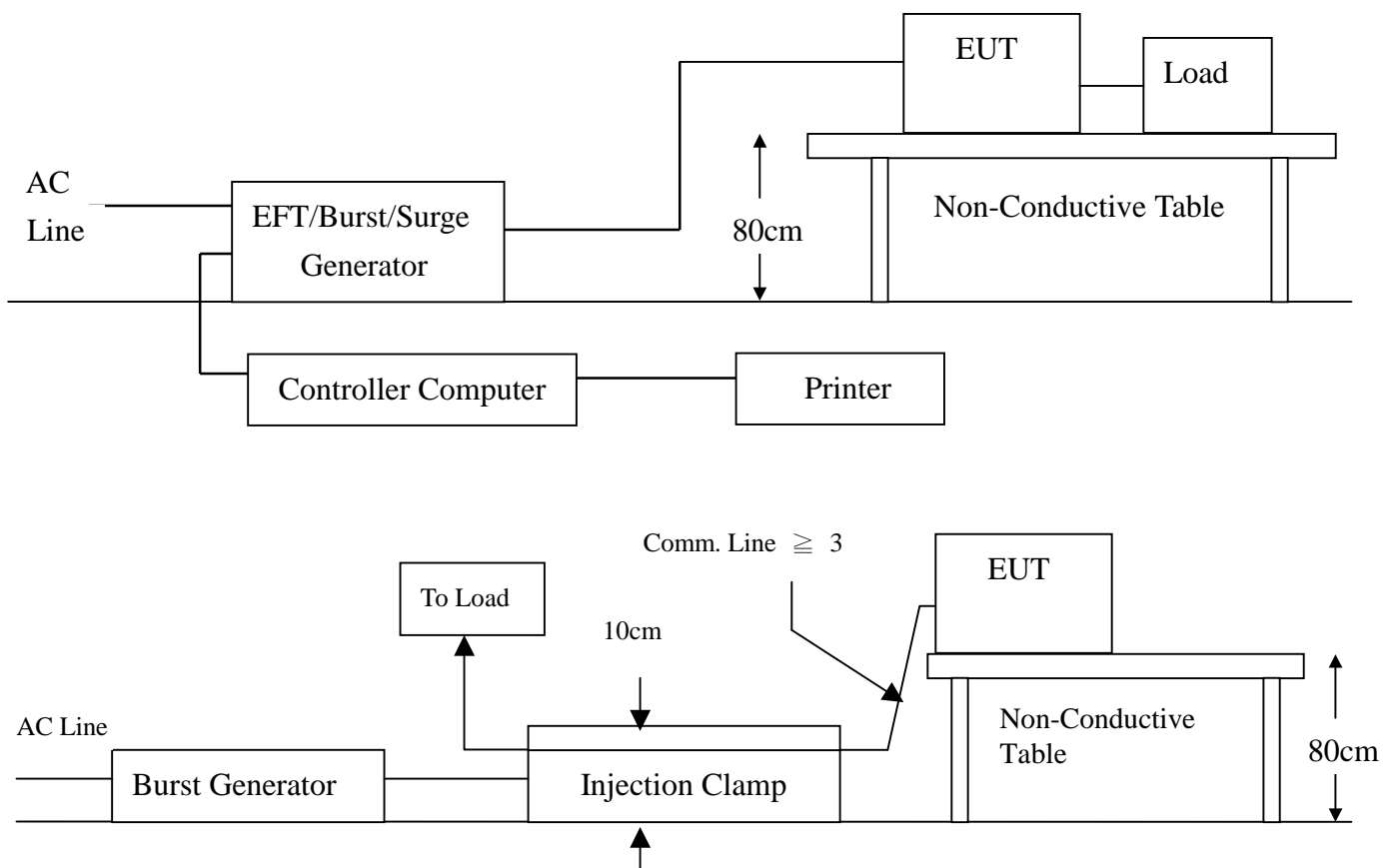



Test Procedure:

1. The EUT and support units were located on a wooden table 0.8 m away from ground reference plane.
2. A 1.0 meter long power cord was attached to EUT during the test.
3. The length of communication cable between communication port and clamp was keeping within 1 meter.
4. A test program was loaded and executed in Windows mode.
5. The data was sent to and monitor (via EUT), filling the screens with upper case of "H" patterns.
6. The test program exercised related support units sequentially.
7. Repeating step 3 to 6 through the test.
8. Recording the test result as shown in following table.

Test conditions:

Impulse Frequency: 5kHz

Tr/Th: 5/50ns

Burst Duration: 15ms

Burst Period: 3Hz

Inject Line	Voltage kV	Inject Method	Result (Pass/Fail)
L1	±1	Direct	Pass
N	±1	Direct	Pass
PE	±1	Direct	Pass
L1 + N	±1	Direct	Pass
L1 + PE	±1	Direct	Pass
N + PE	±1	Direct	Pass
L1 + N + PE	±1	Direct	Pass
LAN Cable	±0.5	Clamp	Pass

Performance & Result:

- Criteria A:** The apparatus continues to operate as intended. No degradation of performance or loss of function is allowed below a performance level specified by the manufacturer, when the apparatus is used as intended. In some cases the performance level may be replaced by a permissible loss of performance.
- Criteria B:** The apparatus continues to operate as intended after the test. No degradation of performance or loss of function is allowed below a performance level specified by the manufacturer, when the apparatus is used as intended. In some cases the performance level may be replaced by a permissible loss of performance. During the test, degradation of performance is however allowed.
- Criteria C:** Temporary loss of function is allowed, provided the functions self recoverable or can be restored by the operation of controls.

PASS **FAILED**

Observation: No any function degraded during the tests.

SECTION 6 IEC 61000-4-5 (SURGE IMMUNITY)

SURGE IMMUNITY TEST

Port : Power Cord
Basic Standard : IEC 61000-4-5
Requirements : +/- 1kV (Line to Line)
: +/- 2kV (Line to Ground)
Performance Criteria : B (Standard require)
Tester : Boss Yu
Temperature : 25°C
Humidity : 60 %

Block Diagram of Test Setup:

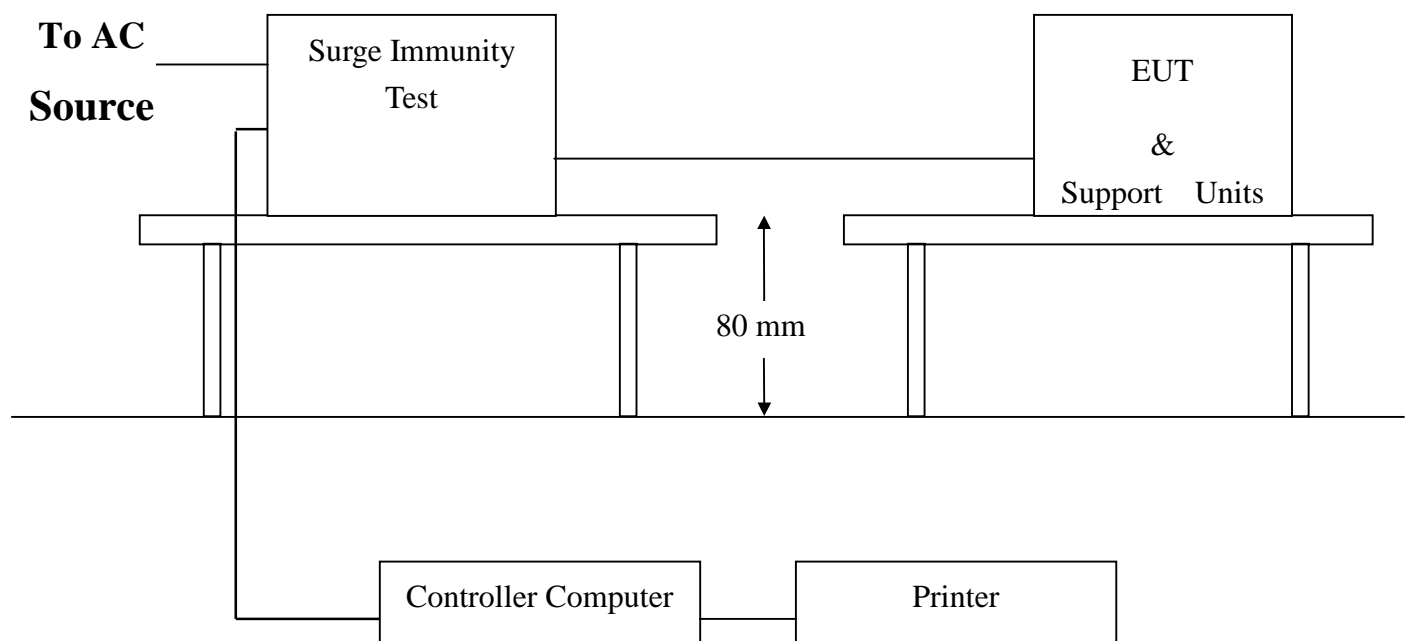



Test Procedure:

1. The EUT was located 0.1 m minimum from all side of the HCP.
2. The support units were located 1 m minimum away from the EUT.
3. A scroll H test program was loaded and executed in Windows mode.
4. The PC sent above message to EUT and related peripherals through the test.
5. Selecting appropriate points of EUT for discharge and put a mark on EUT to show tested points.
6. The following test condition was followed during the tests.

Test conditions:

Voltage Waveform : 1.2/50 us
Current Waveform : 8/20 us
Polarity : Positive/Negative
Phase angle : 0°, 90°, 270°
Number of Test : 5

Coupling Line	Voltage (kV)	Polarity	Coupling Method	Result (Pass/Fail)
L1-L2	1	Positive	Capacitive	Pass
L1-PE	2	Positive	Capacitive	Pass
L2-PE	2	Positive	Capacitive	Pass
L1-L2	1	Negative	Capacitive	Pass
L1-PE	2	Negative	Capacitive	Pass
L2-PE	2	Negative	Capacitive	Pass

Performance & Result:

- Criteria A:** The apparatus continues to operate as intended. No degradation of performance or loss of function is allowed below a performance level specified by the manufacturer, when the apparatus is used as intended. In some cases the performance level may be replaced by a permissible loss of performance.
- Criteria B:** The apparatus continues to operate as intended after the test. No degradation of performance or loss of function is allowed below a performance level specified by the manufacturer, when the apparatus is used as intended. In some cases the performance level may be replaced by a permissible loss of performance. During the test, degradation of performance is however allowed.
- Criteria C:** Temporary loss of function is allowed, provided the functions self recoverable or can be restored by the operation of controls.

PASS **FAILED**

Observation: No any function degraded during the tests.

SECTION 7 IEC 61000-4-6 (CONDUCTED DISTURBANCE/INDUCED BY RADIO-FREQUENCY FIELD)

Port : Power cord and LAN Cable
Basic Standard : IEC 61000-4-6
Requirements : 3 V with Modulated
Injection Method : CDN-M3 for Power Cord
 EM-Clamp for LAN Cable
Tested by : Boss Yu
Performance Criteria : A (Standard require)
Temperature : 25C
Humidity : 60%

Block Diagram of Test Setup:

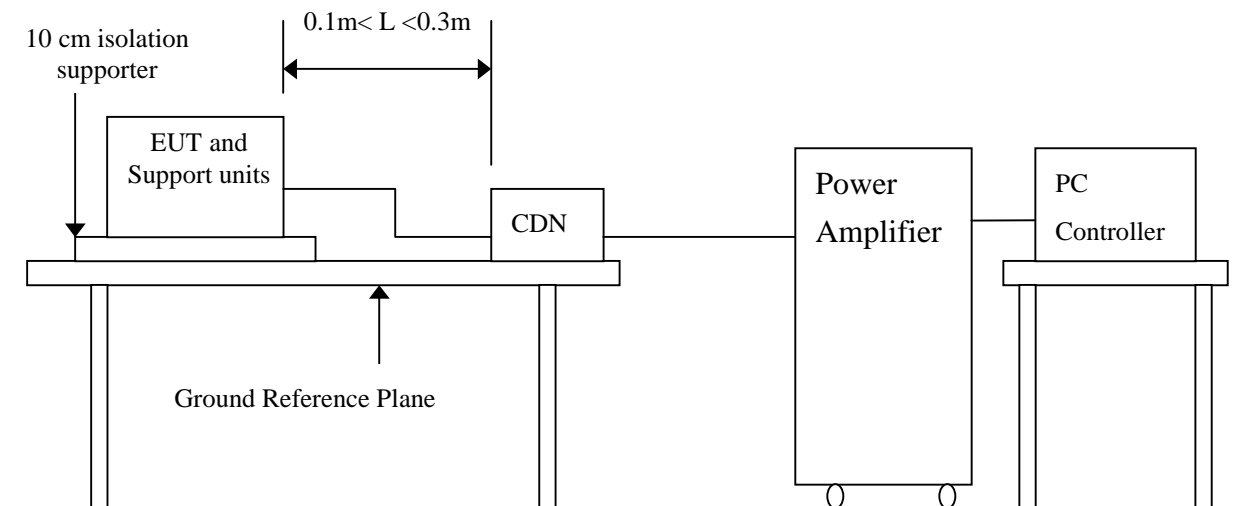

Top view:

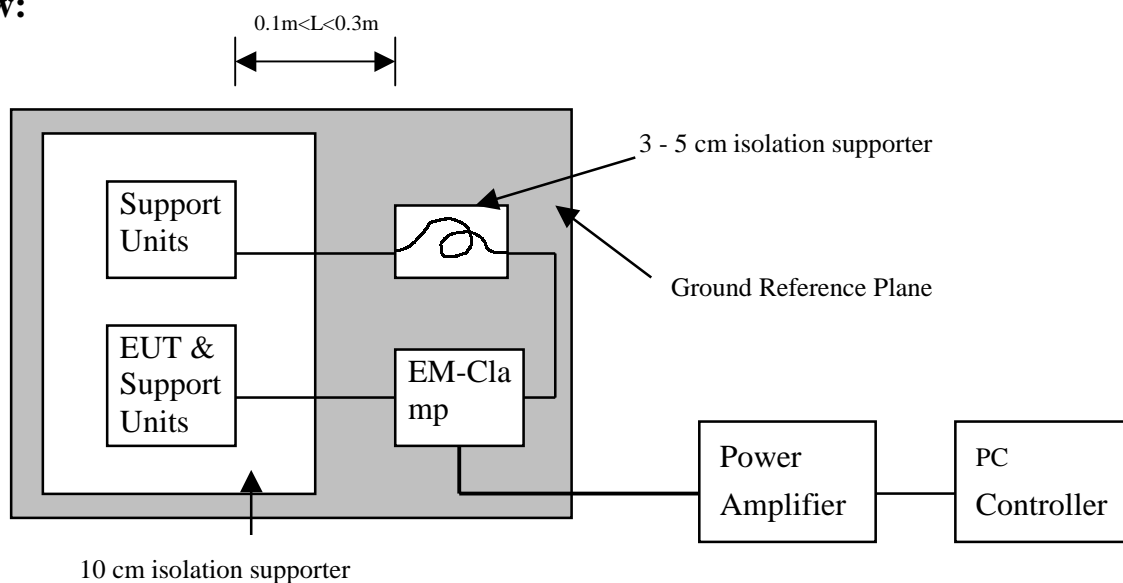



Test Procedure:

1. The EUT and support units were located at a ground reference plane with the interposition of a 0.1 m thickness insulating support and the CDN was located on GRP directly.
2. A 'H' messages were displayed on EUT.
3. Adjusting the monitoring camera to monitor the H message as clear as possible.
4. Setting the testing parameters of CS test software per IEC 61000-4-6.
5. Recording the test result in following table.

Test conditions:

Frequency Range : 0.15MHz-80MHz
Frequency Step : 1% of fundamental
Dwell Time : 3 sec

Range (MHz)	Field	Modulation	Result (Pass/Fail)
0.15-80	3V	Yes	Pass

Performance & Result:

- Criteria A:** The apparatus continues to operate as intended. No degradation of performance or loss of function is allowed below a performance level specified by the manufacturer, when the apparatus is used as intended. In some cases the performance level may be replaced by a permissible loss of performance.
- Criteria B:** The apparatus continues to operate as intended after the test. No degradation of performance or loss of function is allowed below a performance level specified by the manufacturer, when the apparatus is used as intended. In some cases the performance level may be replaced by a permissible loss of performance. During the test, degradation of performance is however allowed.
- Criteria C:** Temporary loss of function is allowed, provided the functions self recoverable or can be restored by the operation of controls.

PASS **FAILED**

Observation: No any function degraded during the tests.

SECTION 8 IEC 61000-4-8 (POWER FREQUENCY MAGNETIC FIELD IMMUNITY TEST)

Port : Enclosure
Basic Standard : IEC 61000-4-8
Requirements : 3 A/m
Performance Criteria : A (Standard Required)
Temperature : N/A
Humidity : N/A

Block Diagram of Test Setup:

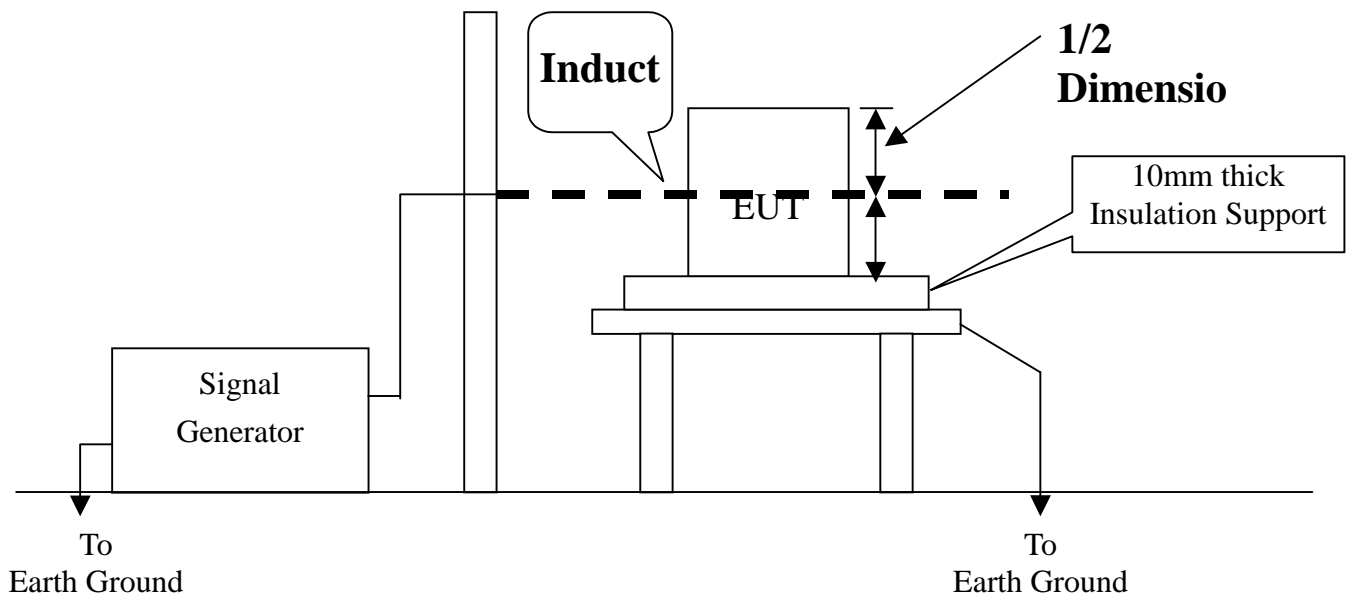



Test Procedure:

1. The EUT and support units were located on Ground Reference Plane with the interposition of a 0.1 m thickness insulation support.
2. Putting the induction coil on horizontal direction.(X direction)
3. A test program was loaded and executed in Windows mode.
4. The data was sent to the screen of EUT and filling the screen with upper case of “H” patterns.
5. The test program exercised related support units sequentially.
6. Repeating step 3 to 5 through the test.
7. Recording the test result as shown in following table.
8. Rotating the induction coil by 90° (Y direction) then repeat step 3 to 7.
9. Rotating the induction coil by 90° again (Z direction) then repeat step 3 to 7.

***. Test conditions:**

Field Strength: 3A/m
Power Freq.: 50Hz
Orientation: X, Y, Z

Orientation	Field	Result (Pass/Fail)	Remark

****Note:** Not applicable, because no any component can be influenced by power magnetic fields.

Performance & Result:

- Criteria A:** The apparatus continues to operate as intended. No degradation of performance or loss of function is allowed below a performance level specified by the manufacturer, when the apparatus is used as intended. In some cases the performance level may be replaced by a permissible loss of performance.
- Criteria B:** The apparatus continues to operate as intended after the test. No degradation of performance or loss of function is allowed below a performance level specified by the manufacturer, when the apparatus is used as intended. In some cases the performance level may be replaced by a permissible loss of performance. During the test, degradation of performance is however allowed.
- Criteria C:** Temporary loss of function is allowed, provided the functions self recoverable or can be restored by the operation of controls.

**** Observation:** N/A

SECTION 9 IEC 61000-4-11 (VOLTAGE DIPS, SHORT INTERRUPTIONS AND VOLTAGE VARIATIONS)

VOLTAGE DIPS / SHORT INTERRUPTIONS

Port : AC mains
Basic Standard : EN 61000-4-11 (1994)
Requirement : PHASE ANGLE 0, 45, 90, 135, 180, 225, 270, 315 degrees

Voltage Dips	Test Level % U_T	Reduction (%)	Duration (periods)	Performance Criteria
	<5	>95	0.5	B
70	30	25	C	

Voltage Interruptions	Test Level % U_T	Reduction (%)	Duration (periods)	Performance Criteria
	<5	>95	250	C

Test Interval : Min. 10 sec.
Tester : Boss Yu
Temperature : 25°C
Humidity : 60%

Block Diagram of Test Setup:

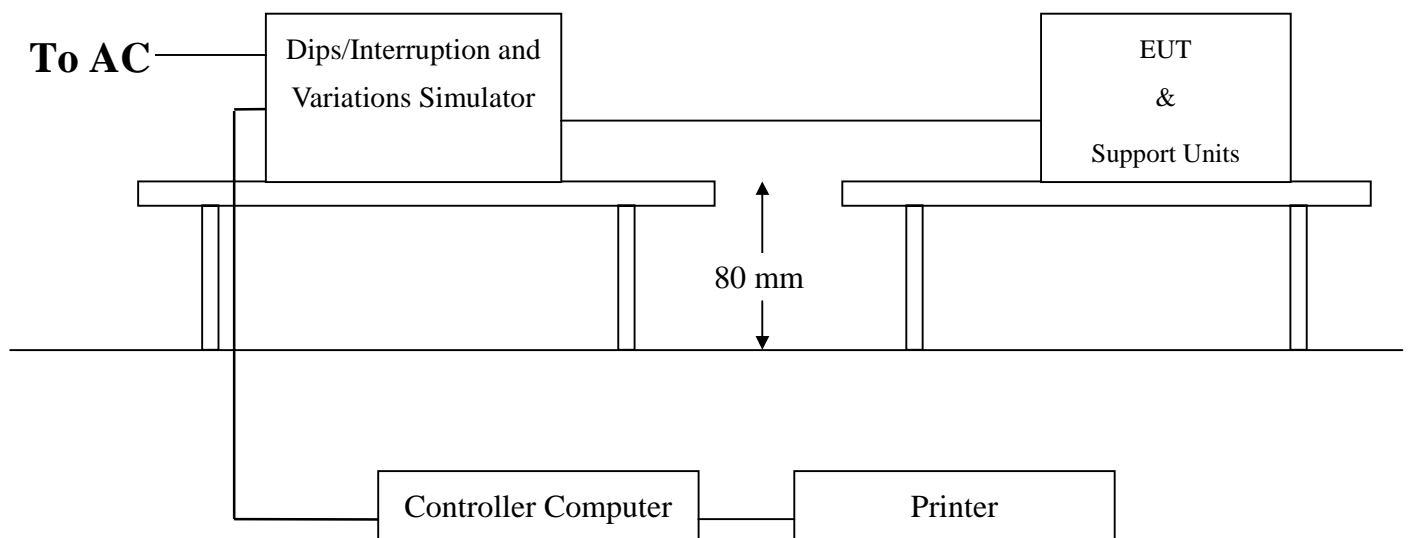



Test Procedure:

1. The EUT and support units were located on a wooden table, 0.8 m away from ground floor.
2. A test program was loaded and executed in Windows mode.
3. The data was sent to Monitor filling the screens with upper case of "H" patterns.
4. The test program exercised related support units sequentially.
5. Setting the parameter of tests and then Perform the test software of test simulator.
6. Conditions changes to occur at 0 degree crossover point of the voltage waveform.
7. Repeating step 3 to 4 through the test.
8. Recording the test result in test record form.

Test conditions:

The duration with a sequence of three dips/interruptions with interval of 10 s minimum
 (Between each test event)

Voltage Dips:

Test Level % U _T	Reduction (%)	Duration (periods)	Observation	Meet Performance Criteria
0	100	0.5	Normal	A
70	30	25	Normal	A

Voltage Interruptions:

Test Level % U _T	Reduction (%)	Duration (periods)	Observation	Meet Performance Criteria
0	100	250	EUT shut down, but can be recovered by manual, as the evens disappear.	C

Normal: No any functions degrade during and after the test.

Performance & Result:

Criteria A: The apparatus continues to operate as intended. No degradation of performance or loss of function is allowed below a performance level specified by the manufacturer, when the apparatus is used as intended. In some cases the performance level may be replaced by a permissible loss of performance.

Criteria B: The apparatus continues to operate as intended after the test. No degradation of performance or loss of function is allowed below a performance level specified by the manufacturer, when the apparatus is used as intended. In some cases the performance level may be replaced by a permissible loss of performance. During the test, degradation of performance is however allowed.

Criteria C: Temporary loss of function is allowed, provided the functions self recoverable or can be restored by the operation of controls.

<input checked="" type="checkbox"/> PASS	<input type="checkbox"/> FAILED
---	--



APPENDIX 1

PHOTOGRAPHS OF TEST SETUP

LINE CONDUCTED EMISSION TEST (EN 55022)



COMMON MODE CONDUCTED EMISSION TEST



RADIATED EMISSION TEST (EN 55022)



POWER HARMONIC & VOLTAGE FLUCTUATION / FLICKER TEST (EN 61000-3-2, EN 61000-3-3)



ELECTROSTATIC DISCHARGE TEST (IEC 61000-4-2)



RADIATED ELECTROMAGNETIC FIELD (IEC 61000-4-3)



FAST TRANSIENTS/BURST TEST (IEC 61000-4-4)



SURGE IMMUNITY TEST (IEC 61000-4-5)



CONDUCTED DISTURBANCE, INDUCED BY RADIO-FREQUENCY FIELDS TEST (IEC 61000-4-6)

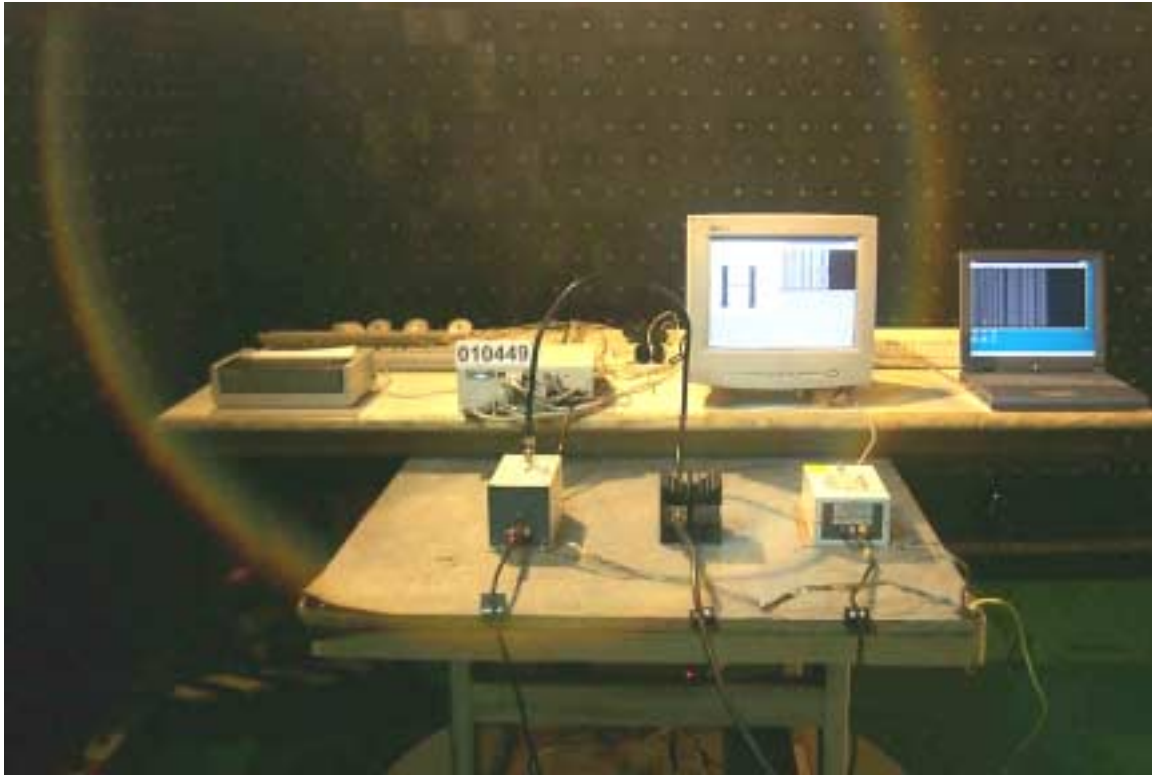

VOLTAGE DIPS / INTERRUPTION TEST (IEC 61000-4-11)





APPENDIX 2

PHOTOGRAPHS OF EUT

Front view of EUT



Back view of EUT



Left view of EUT



Right view of EUT



Bottom view of EUT

