

A B C D E F G H I J A3

ITEM	DATE	REMARK	DESIGNED	APPROVED
1				
2				
3				

1
2
3
4
5
6
7
8
9
10
11

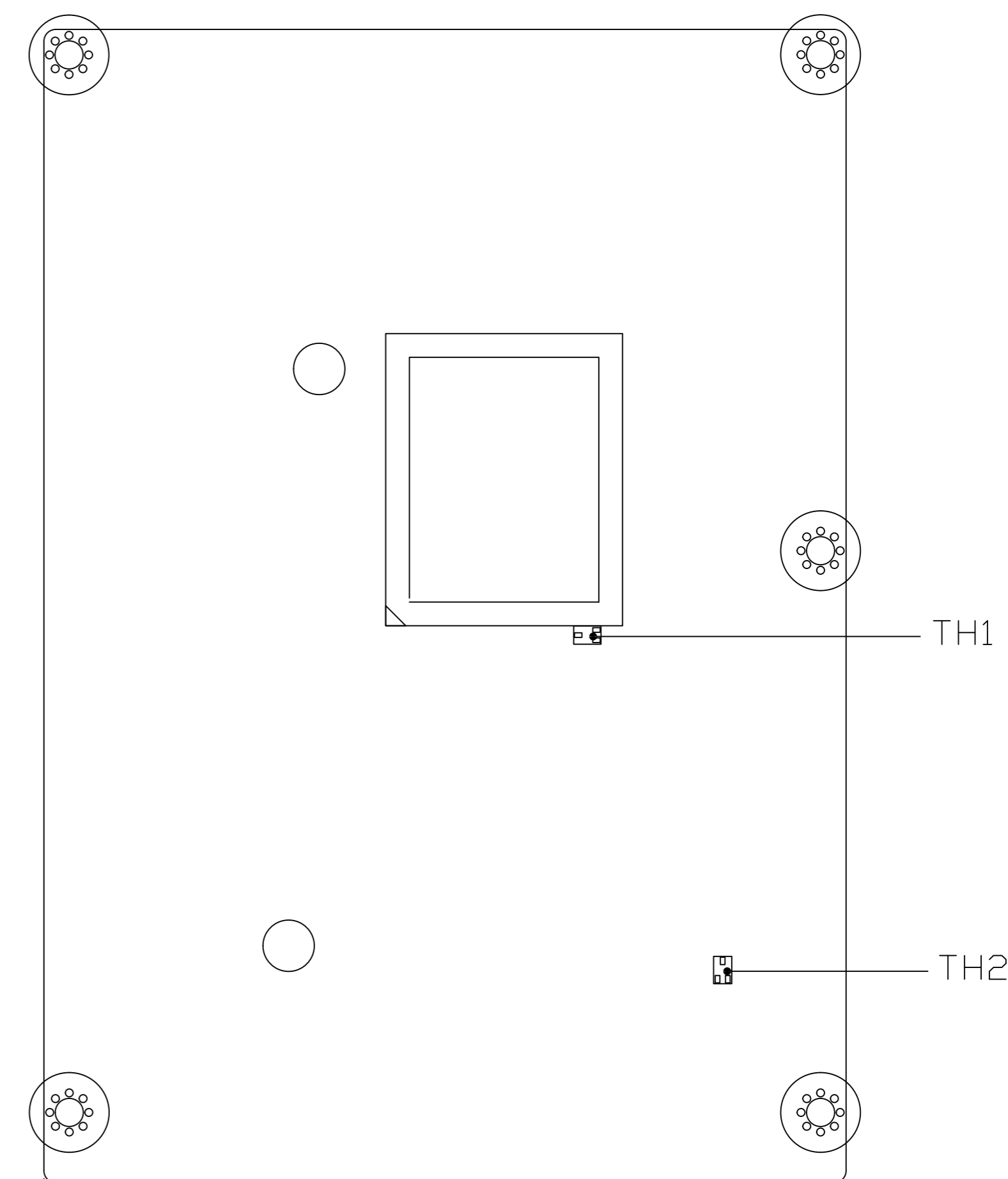
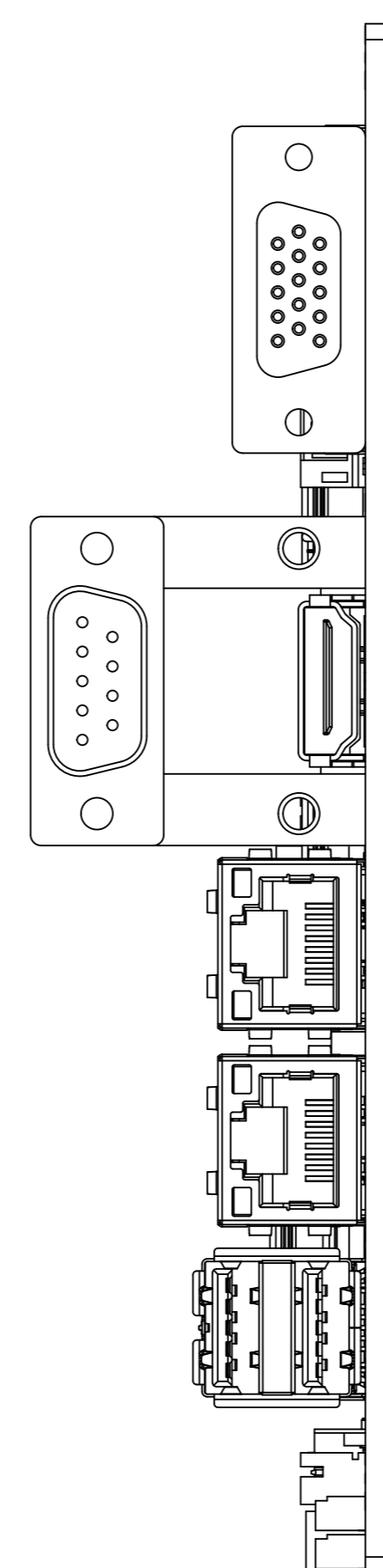
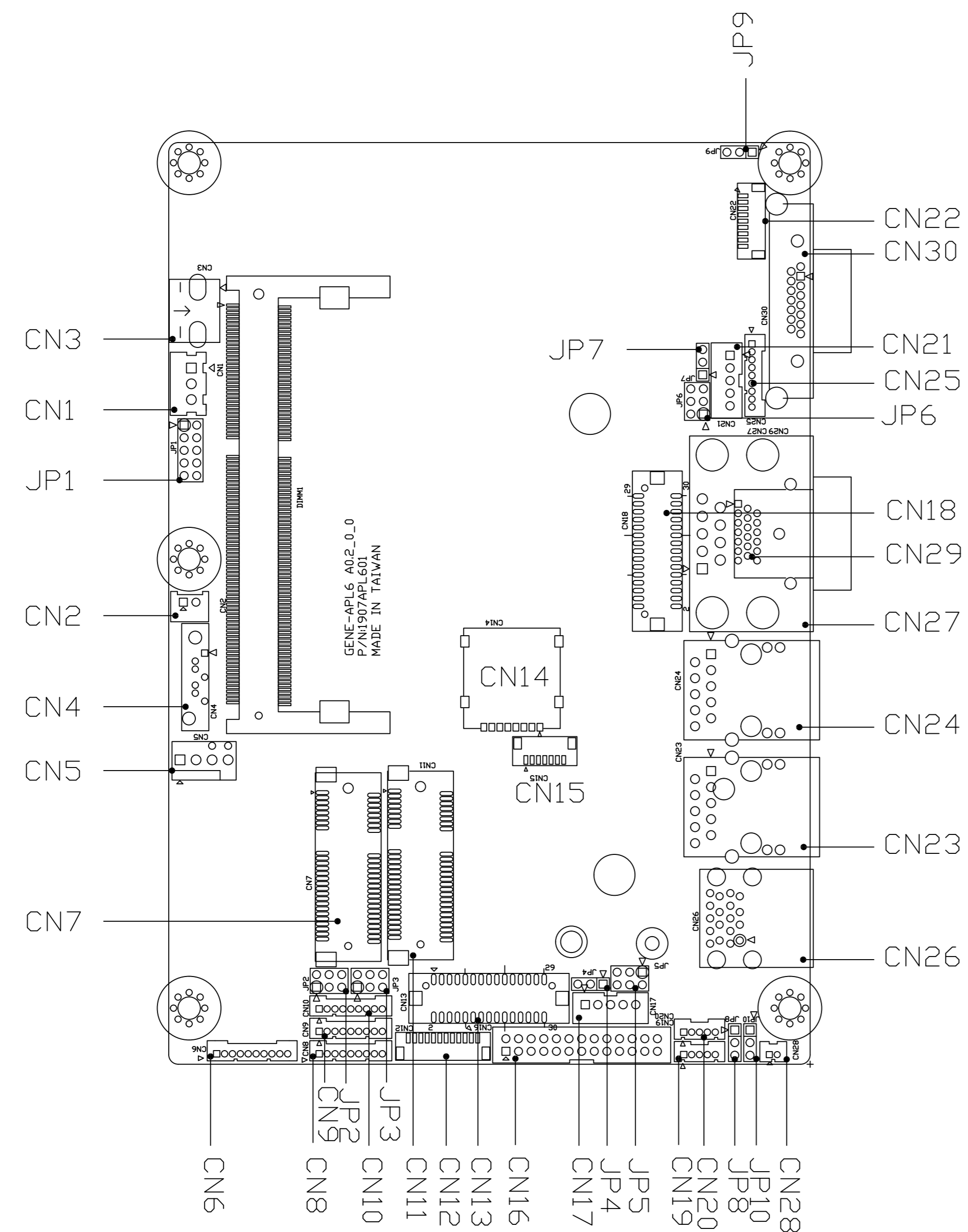

Component Side

Solder Side

GENERAL TOL. >0 ±0.1 >10 ±0.2 >50 ±0.3 >200 ±0.5 >500 ±0.8 ANGLE TOL. ±0.5°	MATERIAL: PCB	PART No. 1907APL602			
	SPEC.: t=1.8mm	DWG No. 1907APL602			
FINISH: NA	UNIT: MM	APPROVED	CHECKED	DESIGNED	NAME PCB_DRAWING
SCALE:			Kevin	Ted	MODEL No. GENE-APL6
			20180209	20180209	REV. A1.0 SHEET: 1 / 1