



# UP Squared Pro 7000

---

Maker Board  
UPN-ADLN01

User's Manual 4<sup>th</sup> Ed

## Copyright Notice

---

This document is copyrighted, 2025. All rights are reserved. The original manufacturer reserves the right to make improvements to the products described in this manual at any time without notice.

No part of this manual may be reproduced, copied, translated, or transmitted in any form or by any means without the prior written permission of the original manufacturer. Information provided in this manual is intended to be accurate and reliable. However, the original manufacturer assumes no responsibility for its use, or for any infringements upon the rights of third parties that may result from its use.

The material in this document is for product information only and is subject to change without notice. While reasonable efforts have been made in the preparation of this document to assure its accuracy, AAEMON assumes no liabilities resulting from errors or omissions in this document, or from the use of the information contained herein.

AAEMON reserves the right to make changes in the product design without notice to its users.

## Acknowledgement

---

All other products' name or trademarks are properties of their respective owners.

- Microsoft®, Windows®, Windows® 10 IoT Enterprise, and Windows® IoT Core are registered trademarks of Microsoft Corp.
- Intel® and Atom® are registered trademarks of Intel Corporation
- Core™ is a trademark of Intel Corporation
- Yocto Project® is a trademark of The Linux Foundation.
- Linux® is a registered trademark of Linus Torvalds in the U.S. and other countries.
- Ubuntu and Canonical are registered trademarks of Canonical Ltd.

All other product names or trademarks are properties of their respective owners.

## Packing List

---

Before setting up your product, please make sure the following items have been shipped:

Item	Quantity
● UPN-ADLN01 (UP Squared Pro 7000) with Heatsink	1

If any of these items are missing or damaged, please contact your distributor or sales representative immediately.

## About this Document

---

This User's Manual contains all the essential information, such as detailed descriptions and explanations on the product's hardware and software features (if any), its specifications, dimensions, jumper/connector settings/definitions, and driver installation instructions (if any), to facilitate users in setting up their product.

Users may refer to the product page at [AAEON.com](http://AAEON.com) for the latest version of this document.

## Safety Precautions

---

Please read the following safety instructions carefully. It is advised that you keep this manual for future references

1. All cautions and warnings on the device should be noted.
2. Make sure the power source matches the power rating of the device.
3. Position the power cord so that people cannot step on it. Do not place anything over the power cord.
4. Always completely disconnect the power before working on the system's hardware.
5. No connections should be made when the system is powered as a sudden rush of power may damage sensitive electronic components.
6. If the device is not to be used for a long time, disconnect it from the power supply to avoid damage by transient over-voltage.
7. Always disconnect this device from any AC supply before cleaning.
8. While cleaning, use a damp cloth instead of liquid or spray detergents.
9. Make sure the device is installed near a power outlet and is easily accessible.
10. Keep this device away from humidity.
11. Place the device on a solid surface during installation to prevent falls
12. Do not cover the openings on the device to ensure optimal heat dissipation.
13. Watch out for high temperatures when the system is running.
14. Do not touch the heat sink or heat spreader when the system is running
15. Never pour any liquid into the openings. This could cause fire or electric shock.
16. As most electronic components are sensitive to static electrical charge, be sure to ground yourself to prevent static charge when installing the internal components. Use a grounding wrist strap and contain all electronic components in any static-shielded containers.

17. If any of the following situations arises, please the contact our service personnel:
  - i. Damaged power cord or plug
  - ii. Liquid intrusion to the device
  - iii. Exposure to moisture
  - iv. Device is not working as expected or in a manner as described in this manual
  - v. The device is dropped or damaged
  - vi. Any obvious signs of damage displayed on the device
18. **DO NOT LEAVE THIS DEVICE IN AN UNCONTROLLED ENVIRONMENT WITH TEMPERATURES BEYOND THE DEVICE'S PERMITTED STORAGE TEMPERATURES (SEE CHAPTER 1) TO PREVENT DAMAGE.**

### **Warning!**



This device complies with Part 15 FCC Rules. Operation is subject to the following two conditions: (1) this device may not cause harmful interference, and (2) this device must accept any interference received including interference that may cause undesired operation.

### **Caution:**

*There is a danger of explosion if the battery is incorrectly replaced. Replace only with the same or equivalent type recommended by the manufacturer. Dispose of used batteries according to the manufacturer's instructions and your local government's recycling or disposal directives.*

### **Attention:**

*Il y a un risque d'explosion si la batterie est remplacée de façon incorrecte. Ne la remplacer qu'avec le même modèle ou équivalent recommandé par le constructeur. Recycler les batteries usées en accord avec les instructions du fabricant et les directives gouvernementales de recyclage.*

## 产品中有毒有害物质或元素名称及含量

AAEON 主板/子板/背板

QO4-381 Rev.A2

部件名称	有毒有害物质或元素					
	铅 (Pb)	汞 (Hg)	镉 (Cd)	六价铬 (Cr(VI))	多溴联苯 (PBB)	多溴二苯醚 (PBDE)
印刷电路板 及其电子组件	×	○	○	○	○	○
外部信号 连接器及线材	×	○	○	○	○	○

本表格依据 SJ/T 11364 的规定编制。

○：表示该有毒有害物质在该部件所有均质材料中的含量均在GB/T 26572标准规定的限量要求以下。

×：表示该有害物质的某一均质材料超出了GB/T 26572的限量要求，然而该部件仍符合欧盟指令2011/65/EU 的规范。

环保使用期限(EFUP (Environmental Friendly Use Period))：10年

备注：此产品所标示之环保使用期限，系指在一般正常使用状况下。

## China RoHS Requirement (EN)

Name and content of hazardous substances in product

AAEON Main Board/Daughter Board/Backplane

QQ4-381 Rev.A2

Part Name	Hazardous Substances					
	铅 (Pb)	汞 (Hg)	镉 (Cd)	六价铬 (Cr(VI))	多溴联苯 (PBB)	多溴二苯醚 (PBDE)
PCB Assemblies	×	○	○	○	○	○
Connector and Cable	×	○	○	○	○	○

The table is prepared in accordance with the provisions of SJ/T 11364.

○: Indicates that said hazardous substance contained in all of the homogenous materials for this product is below the limit requirement of GB/T 26572.

×: Indicates that said hazardous substance contained in at least one of the homogenous materials used for this part is above the limit requirement of GB/T 26572. But this product still be compliance with 2011/65/EU Directive (allowed with 2011/65/EU Annex III of RoHS exemption with number 6(c),7(a),7(c)-1).

EFUP (Environment Friendly Use Period) value: 10 years

Notes: This product defined period of use is under normal condition.

# Table of Contents

---

<b>Chapter 1 - Product Specifications</b> .....	<b>1</b>
1.1 Specifications.....	2
<b>Chapter 2 – Hardware Information</b> .....	<b>4</b>
2.1 Dimensions .....	5
2.2 Jumpers and Connectors.....	6
2.3 List of Jumpers and Connectors.....	8
2.3.1 Power Button (SW1).....	9
2.3.2 RTC (CN1).....	10
2.3.3 M.2 2280 M-Key Slot (CN2).....	11
2.3.4 M.2 3052 B-Key Slot (CN3).....	12
2.3.5 M.2 2230 E-Key Slot (CN4).....	14
2.3.6 Dual RJ-45 LAN Port (CN6).....	15
2.3.7 HDMI/DP Port (CN8).....	16
2.3.8 CSI (CN9).....	17
2.3.9 SATA Connector (CN10).....	19
2.3.10 SATA Power Connector (CN11).....	20
2.3.11 USB Type-C Port (CN12).....	21
2.3.12 Dual USB Type-A Port (CN13) .....	22
2.3.13 USB 2.0/UART 1x10P Wafer (CN14).....	23
2.3.14 RS-232/422/485 1x10P Wafer (COM 1) (CN15).....	24
2.3.15 RS-232/422/485 1x10P Wafer (COM 2) (CN16).....	25
2.3.16 40-Pin HAT (CN17).....	26
2.3.17 CPLD and BIOS Update (CN18) .....	27
2.3.18 DC Power Jack (CN20).....	28
2.3.19 Front Panel 1x6P Wafer (CN21).....	29
2.3.20 DC Terminal Block (Optional with Colay) (CN22).....	30

- 2.3.21 Audio Wafer (CN23).....31
- 2.3.22 12V Connector (CN26)..... 32
- 2.3.23 Fan Connector (J1) ..... 33
- 2.3.24 AT/ATX Mode (JP1)..... 34
- Chapter 3 – Software Installation..... 35**
- 3.1 Linux Setup ..... 36
- 3.2 Windows Drivers Installation ..... 36
- 3.3 Dummy Driver Information ..... 37
- 3.3.1 Dummy Driver Installation ..... 37
- 3.3.2 Uninstalling the Dummy Driver ..... 41
- Appendix A – UP Framework SDK Installation ..... 42**
- A.1 Introduction ..... 43
- A.2 Installation for Windows 10..... 43
- Appendix B – Cables and Connectors ..... 46**
- B.1 Cables and Connectors..... 47

# Chapter 1

---

Product Specifications

## 1.1 Specifications

---

### System

<b>Processor</b>	Intel® Core™ i3-N305 Intel Atom® x7425E Intel® Processor N97 Intel® Processor N50 (formerly Alder Lake-N)
<b>Graphics</b>	Intel® UHD Graphics for 12 <sup>th</sup> Gen Intel® Processors
<b>Memory</b>	Up to 16GB LPDDR5
<b>Storage</b>	Up to 64GB eMMC
<b>I/O</b>	HDMI 2.0b x 1 DP 1.2 x 1 DP 1.4a x 1 (via USB Type-C) Audio Jack x 1 (Mic-In + Line-Out) RS-232/422/485 x 2 (from 10-pin Header)
<b>Camera</b>	MIPI-CSI via 61-Pin FPC Connector
<b>USB</b>	USB 2.0 x 2 (from 10-pin Header x 1) USB 3.2 Gen 2 (Type-A) x 2 USB 3.2 Gen 2 (Type-C) x 1
<b>Expansion</b>	40 pin GPIO x 1 M.2 2230 E-Key x 1 (CNVI, PCIe Gen 3 [x1], USB 2.0) M.2 2280 M-Key x 1 (PCIe Gen 3 [x2], USB 2.0) M.2 3052 B-Key x 1 (USB 3.2 Gen 2 only) SATA 6Gb/s x 1
<b>Display Interface</b>	HDMI 2.0b x 1 DP 1.2 x 1 DP 1.4a x 1 (via USB Type-C)

## System

Ethernet	2.5GbE x 2 (Intel® Ethernet Controller I226-IT)
Security	Onboard TPM 2.0
RTC	Yes
OS Support	Windows® 10 IoT Enterprise Ubuntu 22.04 LTS Yocto 4

## Power Requirement

Power	12V, 6A
Power Supply Type	AT/ATX
Power Consumption	26W ~ 35W

## Mechanical

Dimension	4" x 4" (101.6mm x 101.6mm)
Net Weight	0.44 lb (0.20 Kg)
Gross Weight	0.77 lb (0.35 Kg)

## Environment

Operating Temperature	32°F ~ 140°F (0°C ~ 60°C) / 0.5 airflow WiTAS1: -4°F ~ 158°F (-20°C ~ 70°C)
Operation Humidity	0% ~ 90% relative humidity, non-condensing
MTBF	422,053
Certification	CE/FCC Class A, RoHS Compliant, REACH

# Chapter 2

---

Hardware Information

## 2.1 Dimensions

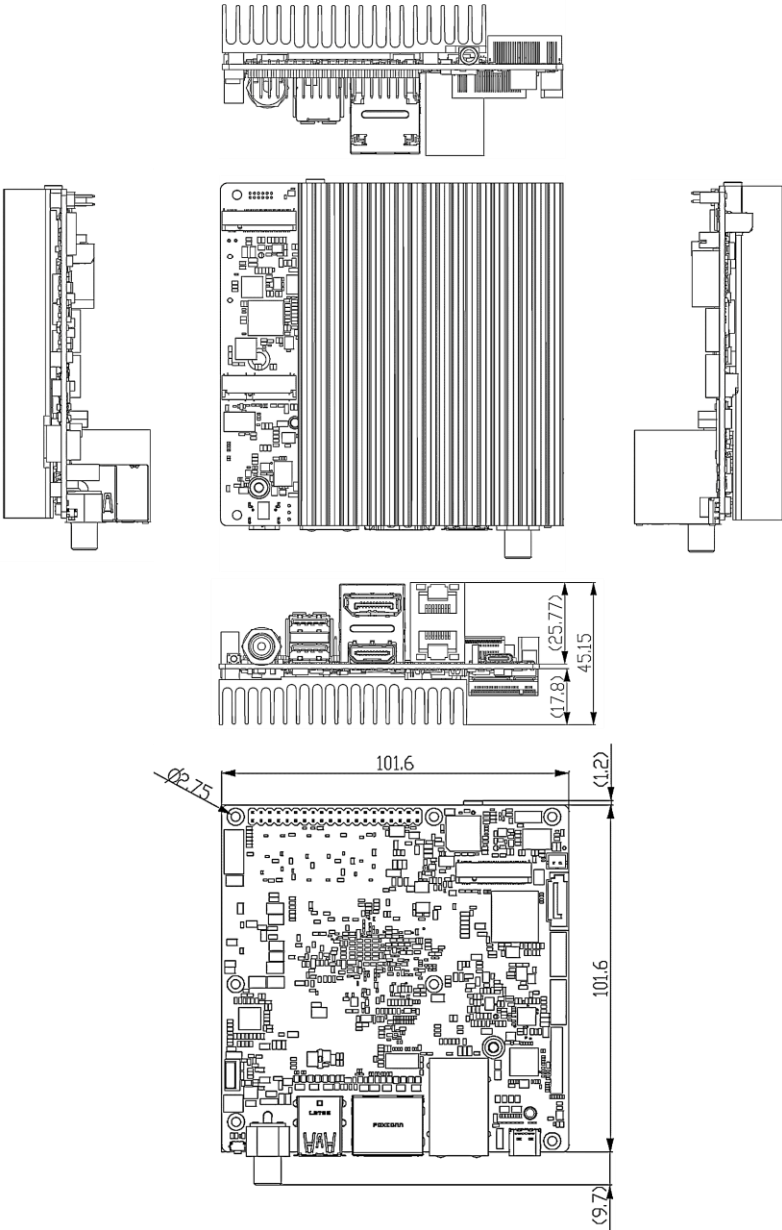

## 2.2 Jumpers and Connectors

Top:

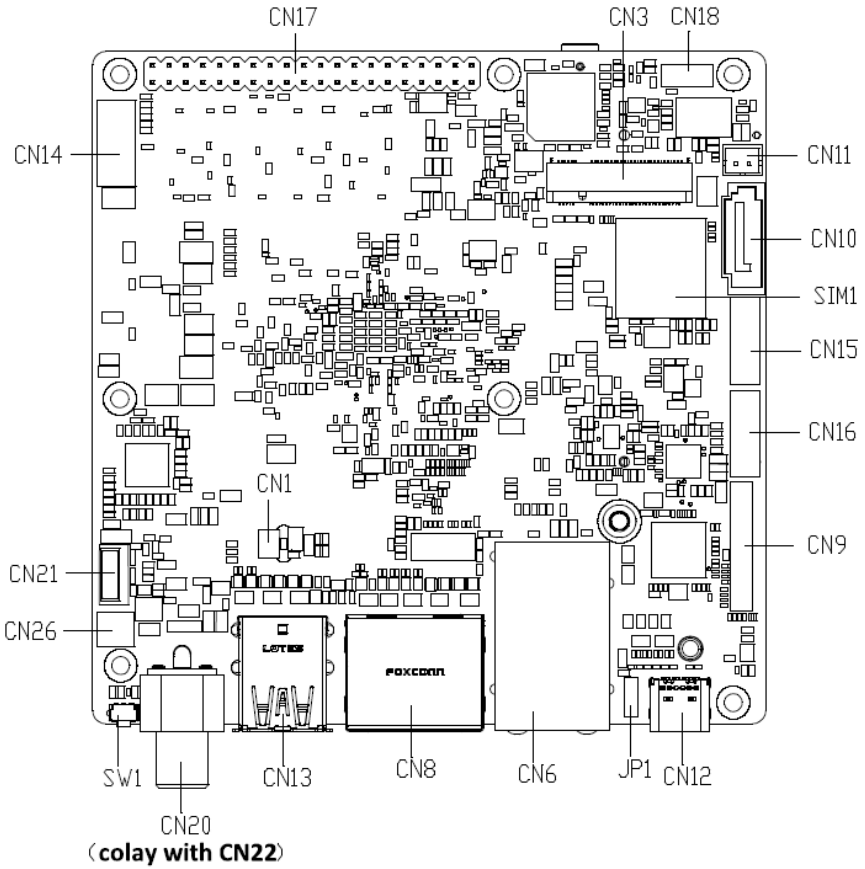

Bottom:

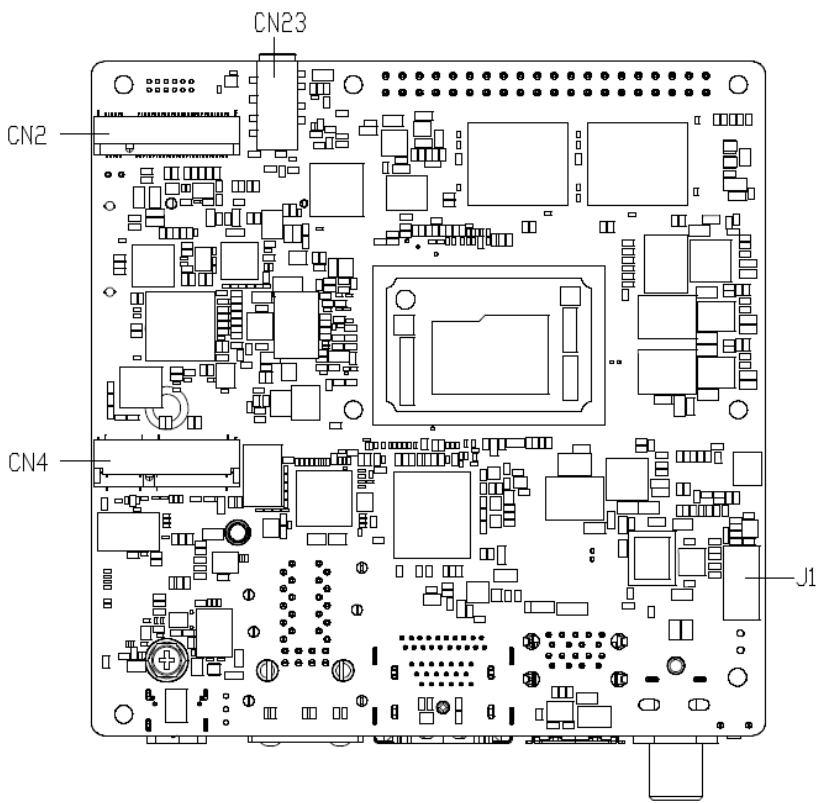

## 2.3 List of Jumpers and Connectors

Please refer to the table below for all of the board's jumpers and connectors that you can configure for your application

Label	Function
SW1	Power Button
CN1	RTC
CN2	M.2 2280 M-Key Slot
CN3	M.2 3052 B-Key Slot
CN4	M.2 2230 E-Key Slot
CN6	Dual RJ-45LAN Port
CN8	HDMI/DP Port
CN9	CSI
CN10	SATA Connector
CN11	SATA Power Connector
CN12	USB Type-C Port
CN13	Dual USB Type-A Port
CN14	USB 2.0/UART 1x10P Wafer
CN15	RS-232/422/485 1x10P Wafer (COM 1)
CN16	RS-232/422/485 1x10P Wafer (COM 2)
CN17	40-Pin HAT
CN18	CPLD and BIOS Update
CN20	DC Power Jack
CN21	Front Panel 1x6P Wafer
CN22	DC Terminal Block (Optional with Colay)
CN23	Audio Wafer
CN26	12V Connector
J1	Fan Connector
JP1	AT/ATX Mode
SIM1	Nano SIM Card Connector

### 2.3.1 Power Button (SW1)

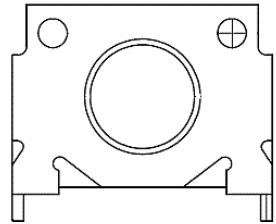
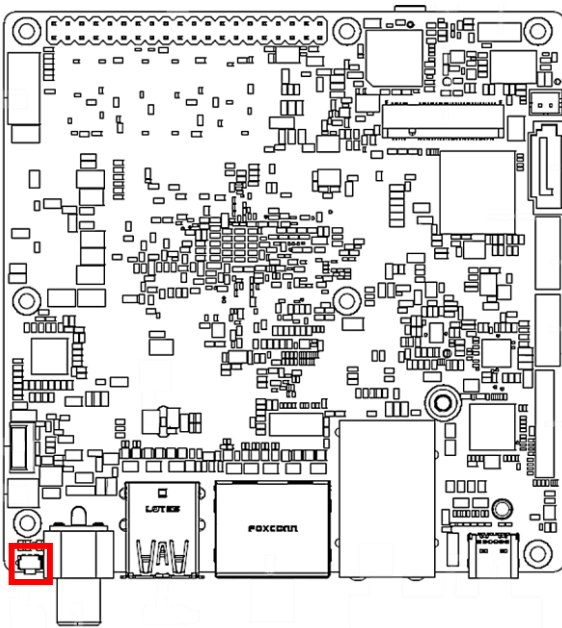

Switch Position	Function
SW1 1	(Default)
SW1 0	Power ON

### 2.3.2 RTC (CN1)

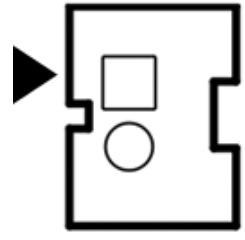
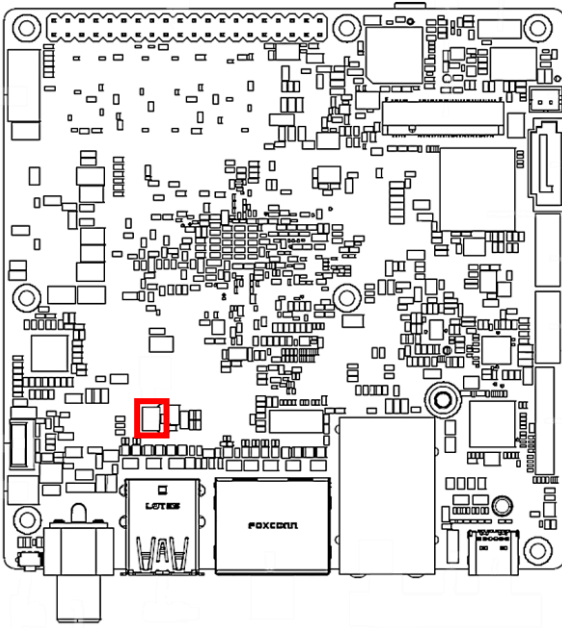

Pin	Signal	Pin	Signal
1	RTC_VCC	2	GND

### 2.3.3 M.2 2280 M-Key Slot (CN2)

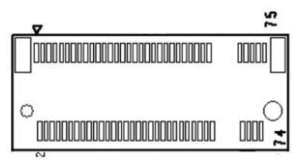
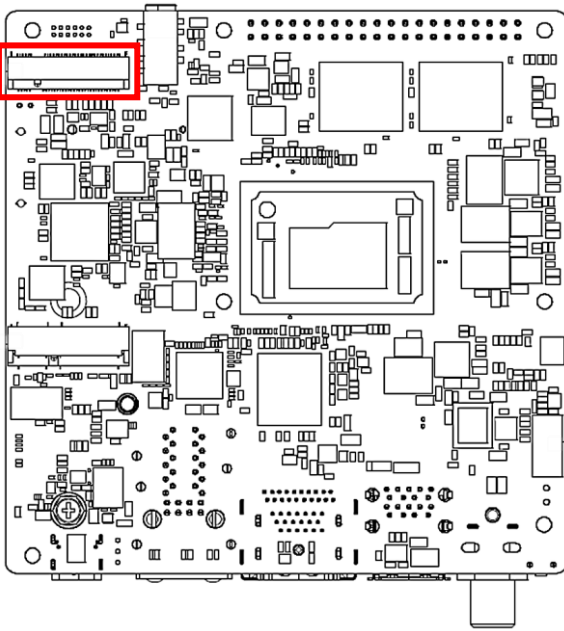

Pin	Signal	Pin	Signal	Pin	Signal
1	GND	2	+3.3V	3	NC
4	+3.3V	5	NC	6	FULL_CARD_POWER
7	NC	8	NC	9	GND
10	NC	11	NC	12	+3.3V
13	NC	14	+3.3V	15	GND
16	+3.3V	17	NC	18	+3.3V
19	NC	20	NC	21	GND
22	NC	23	NC	24	NC
25	NC	26	NC	27	GND
28	NC	29	PCIE_RXN10	30	NC
31	PCIE_RXP10	32	NC	33	GND
34	NC	35	PCIE_TXN10	36	NC
37	PCIE_TXP10	38	NC	39	GND
40	SMB_CLK_1V8	41	PCIE_RXN9	42	SMB_DATA_1V8
43	PCIE_RXP9	44	NC	45	GND

Pin	Signal	Pin	Signal	Pin	Signal
46	NC	47	PCIE_TXN9	48	NC
49	PCIE_TXP9	50	PLT_RST#	51	GND
52	PCIE_CLKREQ#	53	PCIE3_CLK_DN	54	PCIE_WAKE#
55	PCIE3_CLK_DP	56	NC	57	GND
58	NC	59	NC	60	NC
61	NC	62	NC	63	NC
64	NC	65	NC	66	NC
67	NC	68	NC	69	NC
70	+3.3V	71	GND	72	+3.3V
73	GND	74	+3.3V	75	GND

### 2.3.4 M.2 3052 B-Key Slot (CN3)

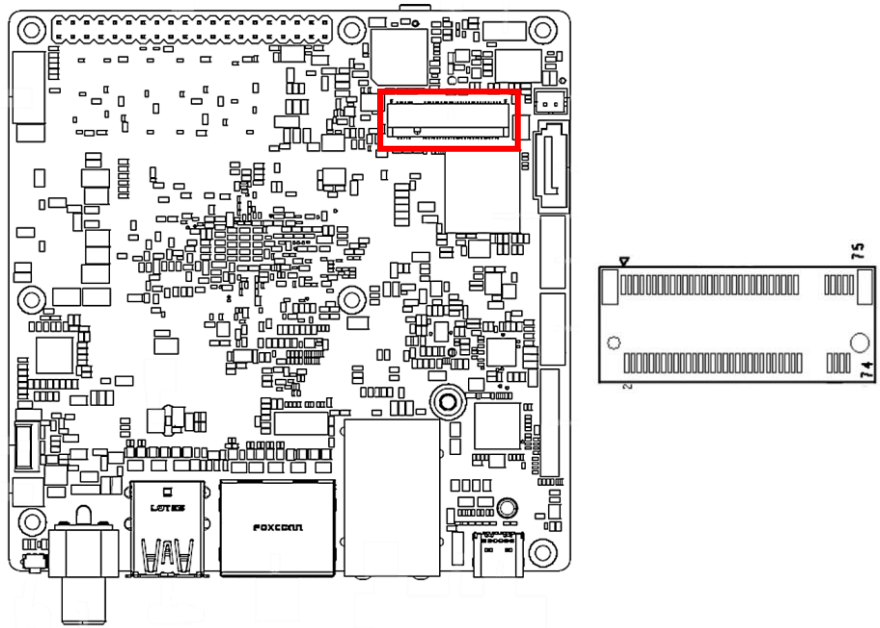

Pin	Signal	Pin	Signal	Pin	Signal
1	NC	2	+3.3V	3	GND
4	+3.3V	5	GND	6	FULL_CARD_PWR_OFF#(1.8V)

Pin	Signal	Pin	Signal	Pin	Signal
7	USB2_D+	8	W_DISABLE#1	9	USB2_D-
10	NC	11	GND	12	NC
13	NC	14	NC	15	NC
16	NC	17	NC	18	NC
19	NC	20	NC	21	NC
22	NC	23	NC	24	NC
25	NC	26	NC	27	GND
28	NC	29	USB3_RX3-	30	UIM_RST
31	USB3_RX3+	32	UIM_CLK	33	GND
34	UIM_DAT	35	USB3_PX3-	36	UIM_PWR
37	USB3_PX3+	38	NC	39	GND
40	NC	41	NC	42	NC
43	NC	44	NC	45	GND
46	NC	47	NC	48	NC
49	NC	50	PLT_RST#(3.3V)	51	GND
52	NC	53	NC	54	NC
55	NC	56	NC	57	GND
58	NC	59	NC	60	NC
61	NC	62	NC	63	NC
64	NC	65	NC	66	NC
67	PLT_RST#(1.8V)	68	NC	69	NC
70	+3.3V	71	GND	72	+3.3V
73	GND	74	+3.3V	75	GND

### 2.3.5 M.2 2230 E-Key Slot (CN4)

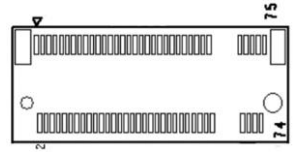
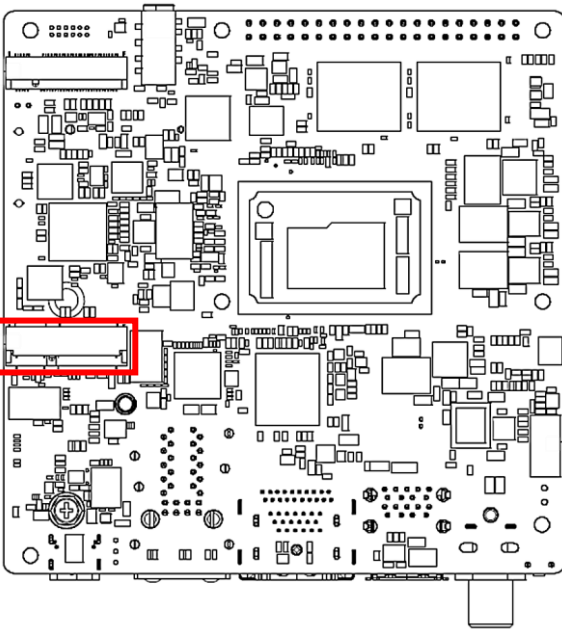

Pin	Signal	Pin	Signal	Pin	Signal
1	GND	2	+3.3V	3	USB2_D8+
4	+3.3V	5	USB2_D8-	6	NC
7	GND	8	NC	9	CNV_WR_LANE1_D N
10	CNV_RF_RST#	11	CNV_WR_LANE1_DP	12	NC
13	GND	14	CNV_CLKREQ_R	15	CNV_WR_LANE0_D N
16	NC	17	CNV_WR_LANE0_DP	18	GND
19	GND	20	NC	21	CNV_WR_CLK_DN
22	CNV_RGI_RSP_R	23	CNV_WR_CLK_DP	24	NC
25	NC	26	NC	27	NC
28	NC	29	NC	30	NC
31	NC	32	CNV_RGI_DT	33	GND
34	CNV_RGI_RSP	35	PCIE11_TXP	36	CNV_BRI_DT
37	PCIE11_TXN	38	NC	39	GND

Pin	Signal	Pin	Signal	Pin	Signal
40	NC	41	PCIE11_RXP	42	NC
43	PCIE11_RXN	44	NC	45	GND
46	NC	47	PCIE_CLK2P	48	NC
49	PCIE_CLK2N	50	SUS_CLK	51	GND
52	WIFI_RST#	53	PCIE_CLKREQ#	54	BT_EN
55	PCIE_WAKE#	56	WIFI_EN	57	GND
58	NC	59	CNV_WT_LANE1_DN	60	NC
61	CNV_WT_LANE1_DP	62	NC	63	GND
64	NC	65	CNV_WT_LANE0_DN	66	NC
67	CNV_WT_LANE0_DP	68	NC	69	GND
70	NC	71	CNV_WT_CLK_DN	72	+3.3V
73	CNV_WT_CLK_DP	74	+3.3V	75	GND

### 2.3.6 Dual RJ-45 LAN Port (CN6)

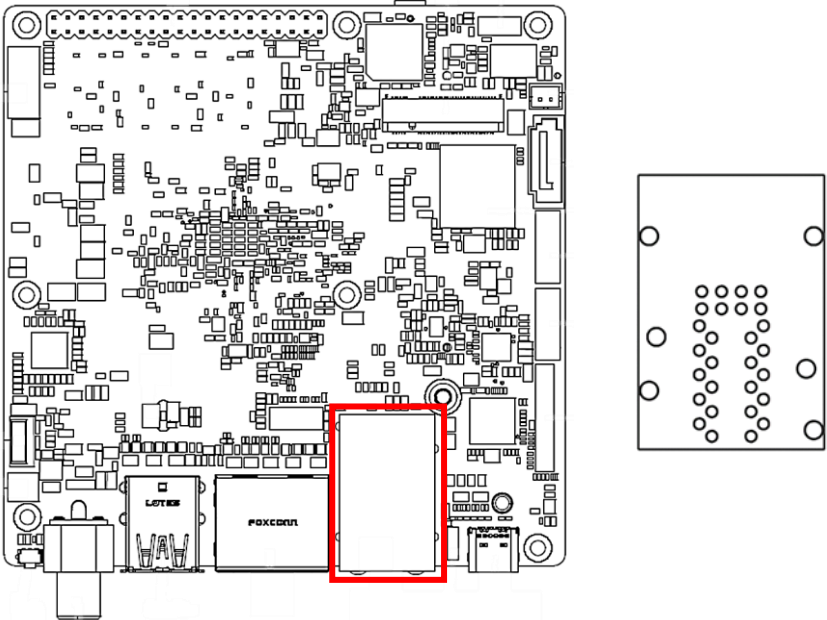

Pin	Signal	Pin	Signal	Pin	Signal
R1A	LAN1_MDIO+	R2A	LAN1_MDIO-	R3A	LAN1_MDI1+

Pin	Signal	Pin	Signal	Pin	Signal
R4A	LAN1_MDI1-	R5A	LAN1_MDI2+	R6A	LAN1_MDI2-
R7A	LAN1_MDI3+	R8A	LAN1_MDI3-	R9A	GND
R10A	GND	L1A	LAN1_ACTLED-	L2A	LAN1_ACTLED+
L3A	LAN1_LINK2500#	L4A	LAN1_LINK1000#	R1B	LAN2_MDI0+
R2B	LAN2_MDI0-	R3B	LAN2_MDI1+	R4B	LAN2_MDI1-
R5B	LAN2_MDI2+	R6B	LAN2_MDI2-	R7B	LAN2_MDI3+
R8B	LAN2_MDI3-	R9B	GND	R10B	GND
L1B	LAN2_ACTLED-	L2B	LAN2_ACTLED+	L3B	LAN2_LINK2500#
L4B	LAN2_LINK1000#				

### 2.3.7 HDMI/DP Port (CN8)

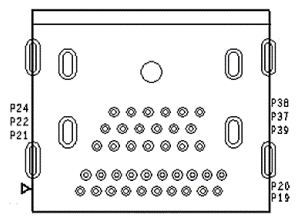
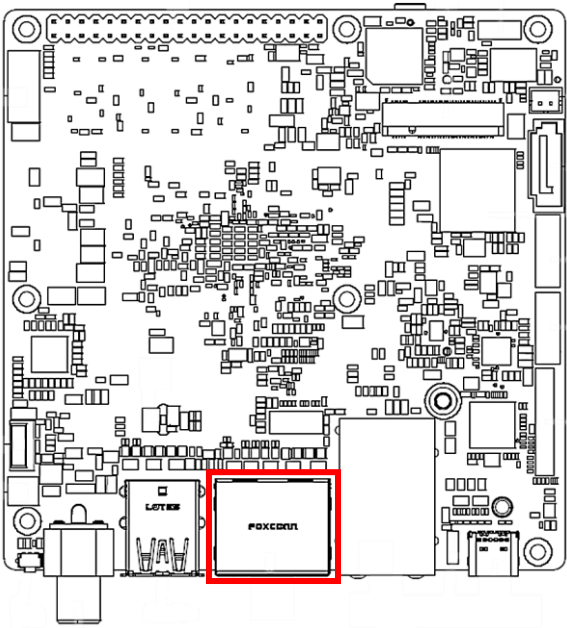

Pin	Signal	Pin	Signal	Pin	Signal
P1	DP_TXP0	P2	GND	P3	DP_TXN0
P4	DP_TXP1	P5	GND	P6	DP_TXN1
P7	DP_TXP2	P8	GND	P9	DP_TXN2
P10	DP_CLK+	P11	GND	P12	DP_CLK-

Pin	Signal	Pin	Signal	Pin	Signal
P13	CONFIG1	P14	CONFIG2	P15	DP_AUX_P
P16	GND	P17	DP_AUX_N	P18	DP_HPDP
P19	GND	P20	3.3V	P21	HDMI_TXP2
P22	GND	P23	HDMI_TXN2	P24	HDMI_TXP1
P25	GND	P26	HDMI_TXN1	P27	HDMI_TXP0
P28	GND	P29	HDMI_TXN0	P30	HDMI_CLK+
P31	GND	P32	HDMI_CLK-	P33	NC
P34	NC	P35	DDC_CLK	P36	DDC_DATA
P37	GND	P38	5V	P39	HDMI_HPDP

### 2.3.8 CSI (CN9)

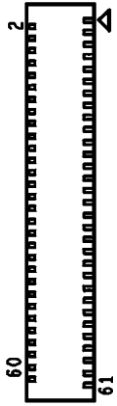
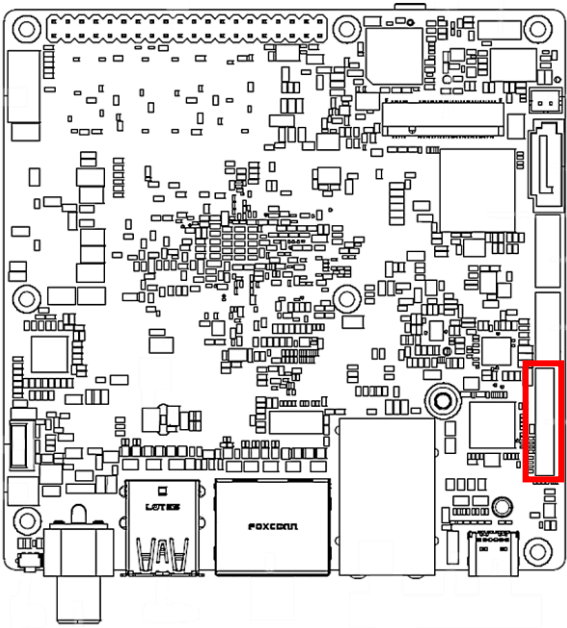

Pin	Signal	Pin	Signal
1	GND	2	CSI_A_D0_DN
3	CSI_A_D0_DP	4	GND
5	CSI_A_D1_DP	6	CSI_A_D1_DN

Pin	Signal	Pin	Signal
7	GND	8	CSI_A_CK_DN
9	CSI_A_CK_DP	10	GND
11	CSI_B_D0_DP	12	CSI_B_D0_DN
13	GND	14	CSI_B_D1_DN
15	CSI_B_D1_DP	16	GND
17	CSI_B_CK_DP	18	CSI_B_CK_DN
19	GND	20	CSI_C_D0_DN
21	CSI_C_D0_DP	22	GND
23	CSI_C_D1_DP	24	CSI_C_D1_DN
25	GND	26	CSI_C_CK_DN
27	CSI_C_CK_DP	28	GND
29	CSI_D_D0_DP	30	CSI_D_D0_DN
31	GND	32	CSI_D_D1_DN
33	CSI_D_D1_DP	34	GND
35	CSI_D_CK_DP	36	CSI_D_CK_DN
37	GND	38	GND
39	CSI_I2S_BCLK_MGCLKOUT1	40	CSI_I2S_SDO_MGCLKOUT0
41	CSI_I2S_FRM_MGCLKOUT3	42	CSI_I2S_SDI_MGCLKOUT2
43	CRD1_PWREN	44	STROBE_CAM
45	CRD2_PWREN	46	CAM1_RST#
47	GPPC_CAM_CLK	48	CAM2_RST#
49	GPPC_PRIVACY_CAM2	50	I2C1_SCL
51	ISH_INT_GP_CRD_GSB	52	I2C1_SDA
53	GPPC_CAM_SYNC	54	I2C5_SCL
55	GPPC_PRIVACY_CAM1	56	I2C5_SDA
57	SUSCLK	58	PM_SLP_S3#
59	INT_IO_GPIO5	60	BUF_PLT_RST_1.8_N
61	GPPC_H4_CSI_RST_N		

### 2.3.9 SATA Connector (CN10)

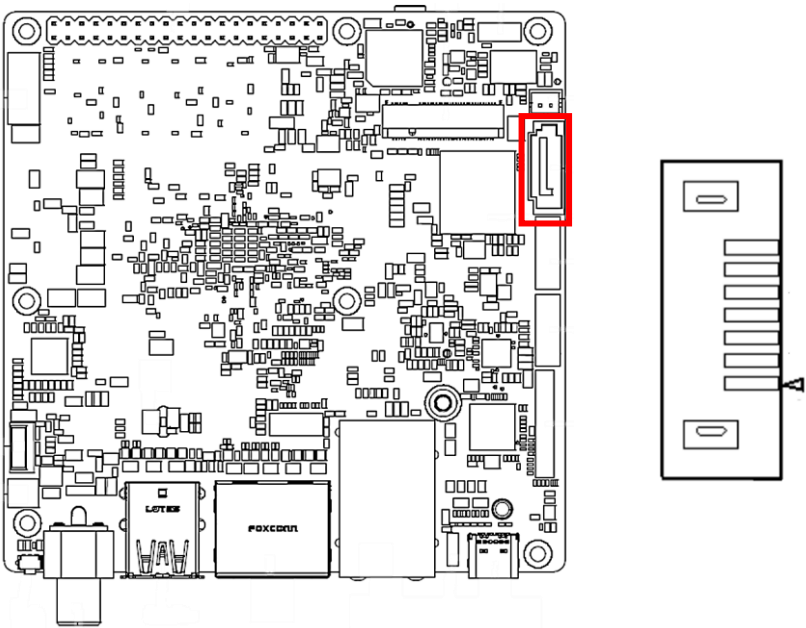

Pin	Signal	Pin	Signal
1	GND	2	SATA_TXP0
3	SATA_TXN0	4	GND
5	SATA_RXN0	6	SATA_RXP0
7	GND		

### 2.3.10 SATA Power Connector (CN11)

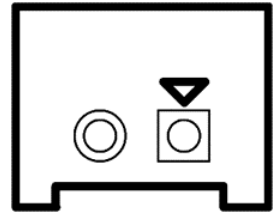
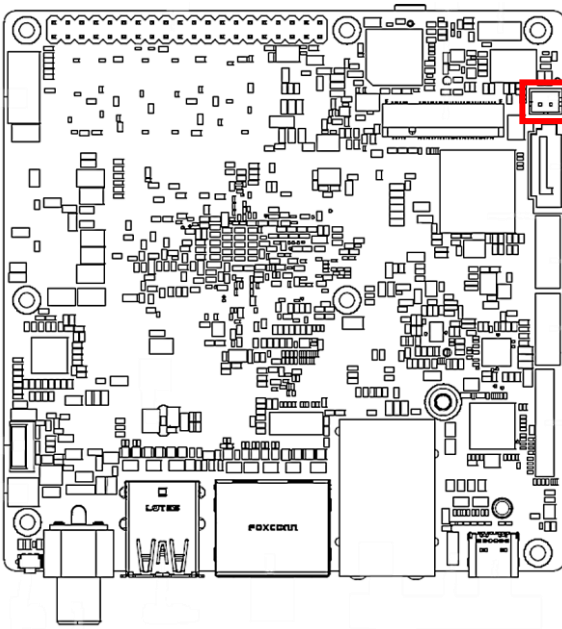

Pin	Signal	Pin	Signal
1	5V	2	GND

### 2.3.11 USB Type-C Port (CN12)

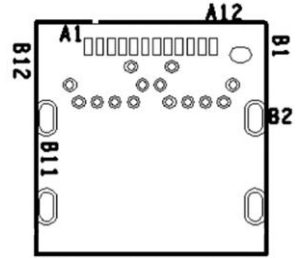
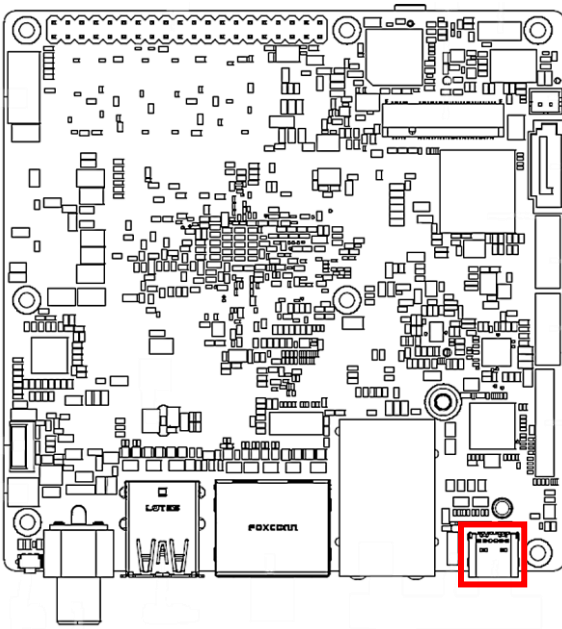

Pin	Signal	Pin	Signal	Pin	Signal
A1	GND	A2	SSTXP1	A3	SSTXN1
A4	+5V	A5	CC1	A6	DP1
A7	DN1	A8	SBU1	A9	+5V
A10	SSRXN2	A11	SSRXP2	A12	GND
B1	GND	B2	SSTXP2	B3	SSTXN2
B4	+5V	B5	CC2	B6	DP1
B7	DN1	B8	SBU2	B9	+5V
B10	SSRXN1	B11	SSRXP1	B12	GND

### 2.3.12 Dual USB Type-A Port (CN13)

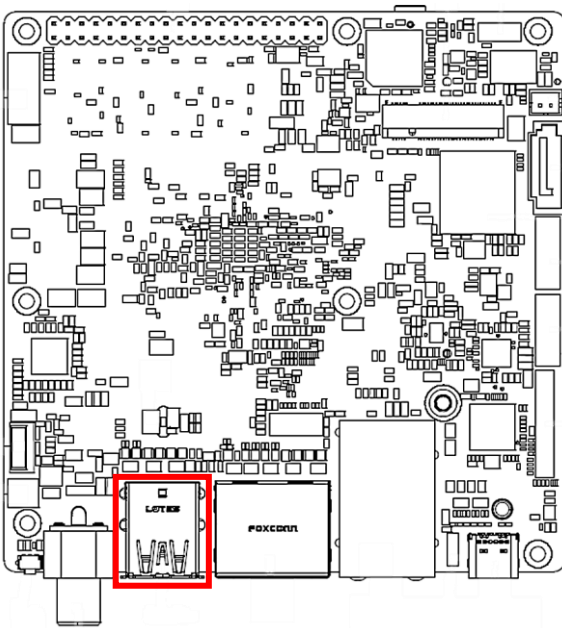

Pin	Signal	Pin	Signal	Pin	Signal
1	+5V	2	USB2_D1-	3	USB2_D1+
4	GND	5	USB3_RX1-	6	USB3_RX1+
7	GND	8	USB3_TX1-	9	USB3_TX1+
10	+5V	11	USB2_D2-	12	USB2_D2+
13	GND	14	USB3_RX2-	15	USB3_RX2+
16	GND	17	USB3_TX2-	18	USB3_TX2+

### 2.3.13 USB 2.0/UART 1x10P Wafer (CN14)

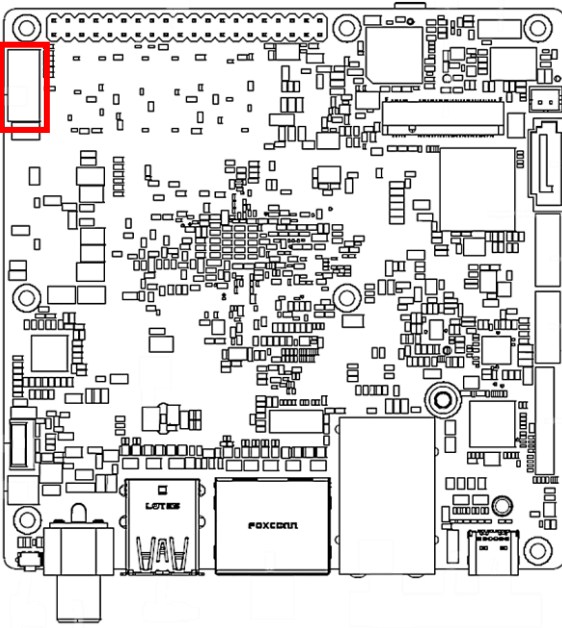

Pin	Signal	Pin	Signal	Pin	Signal
1	+5V	2	USB2_D3-	3	USB2_D3+
4	GND	5	+5V	6	USB2_D4-
7	USB2_D4+	8	GND	9	UART_RX
10	UART_TX				

### 2.3.14 RS-232/422/485 1x10P Wafer (COM 1) (CN15)

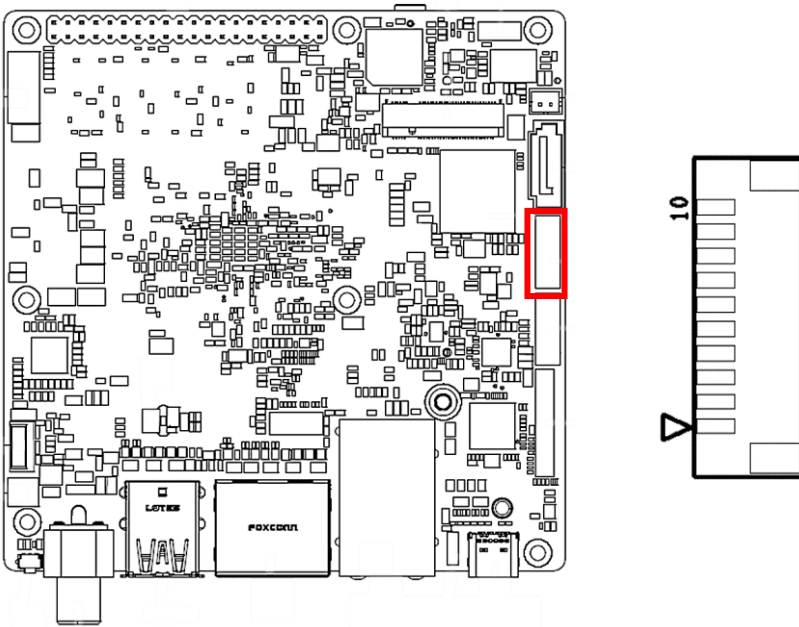

Pin	Signal	Pin	Signal
1	DCD / RS422TX- / RS485-	2	RX / RS422TX+ / RS485+
3	TX / RS422RX+	4	DTR / RS422RX-
5	GND	6	DSR
7	RTS	8	CTS
9	RI	10	NC

2.3.15 RS-232/422/485 1x10P Wafer (COM 2) (CN16)

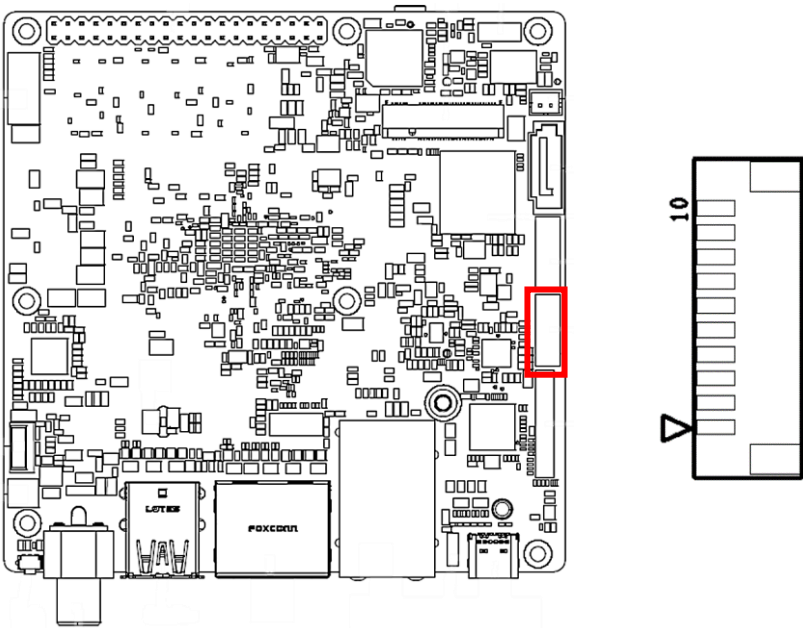

Pin	Signal	Pin	Signal
1	DCD / RS422TX- / RS485-	2	RX / RS422TX+ / RS485+
3	TX / RS422RX+	4	DTR / RS422RX-
5	GND	6	DSR
7	RTS	8	CTS
9	RI	10	NC

### 2.3.16 40-Pin HAT (CN17)

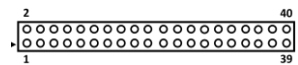
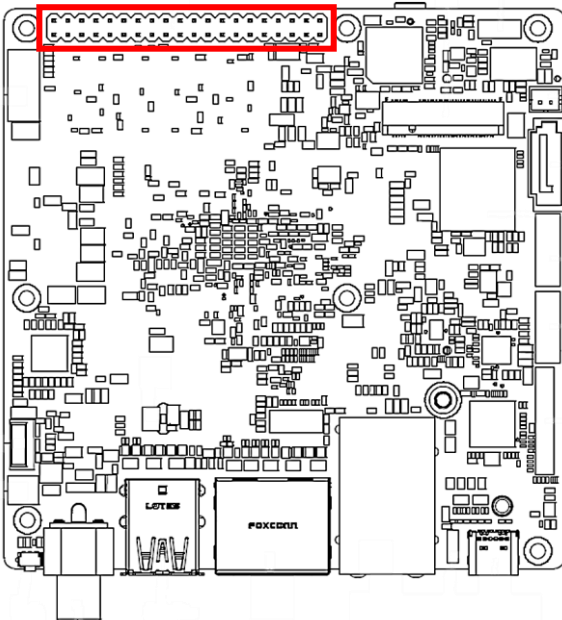

Pin	Signal	Pin	Signal
1	+3.3V	2	+5V
3	I2C1_DAT / GPIO1	4	+5V
5	I2C1_CLK / GPIO2	6	GND
7	ANALOG_DATA / GPIO3	8	UART_TX / GPIO16
9	GND	10	UART_RX / GPIO17
11	GPIO4/ UART_RTS	12	I2S_BCLK / GPIO18
13	GPIO5	14	GND
15	GPIO6	16	GPIO19
17	+3.3V	18	GPIO20
19	SPI_MOSI / GPIO7	20	GND
21	SPI_MISO / GPIO8	22	GPIO21
23	SPI_CLK / GPIO9	24	SPI_CS0 / GPIO22
25	GND	26	GPIO23
27	I2C0_DAT / GPIO10	28	I2C0_CLK / GPIO24
29	GPIO11	30	GND

Pin	Signal	Pin	Signal
31	GPIO12	32	PWM0 / GPIO25
33	PWM1 / GPIO13	34	GND
35	I2S_SYNC / GPIO14	36	GPIO26/ UART_CTS
37	GPIO15	38	I2S_SDI / GPIO27
39	GND	40	I2S_SDO / GPIO28

### 2.3.17 CPLD and BIOS Update (CN18)

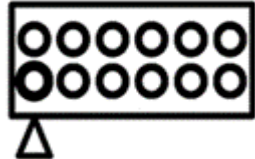
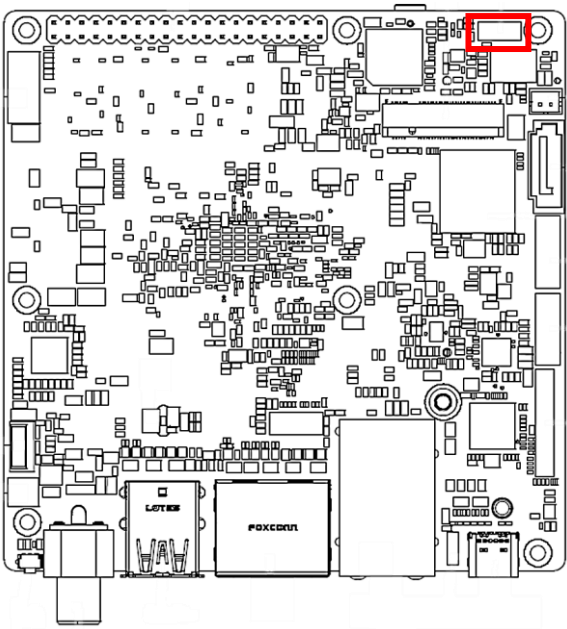

Pin	Signal	Pin	Signal	Pin	Signal
1	JTAG_TCK	2	GND	3	JTAG_TDO
4	1.8V	5	JTAG_TMS	6	SPI_CS
7	SPI_CLK	8	SPI_MISO	9	JTAG_TDI
10	GND	11	SPI_MOSI	12	SPI_HOLD

### 2.3.18 DC Power Jack (CN20)

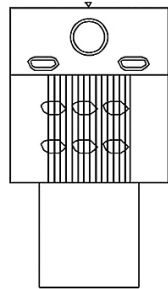
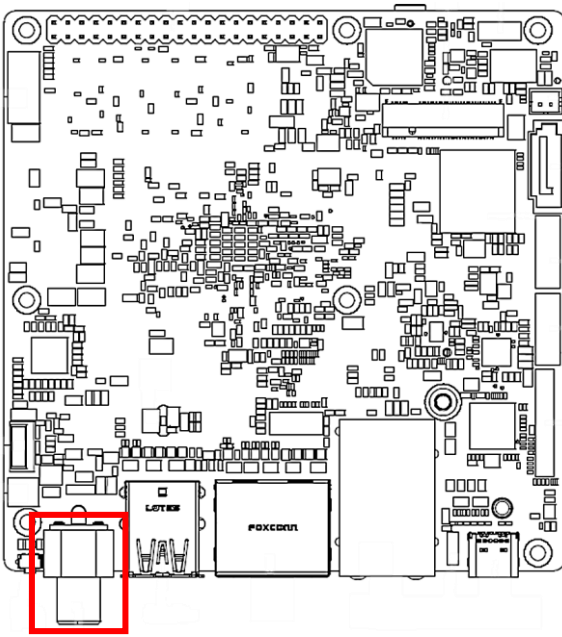

Pin	Signal	Pin	Signal
1	DC_IN	2	GND
3	GND		

### 2.3.19 Front Panel 1x6P Wafer (CN21)

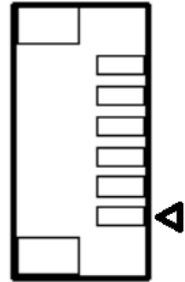
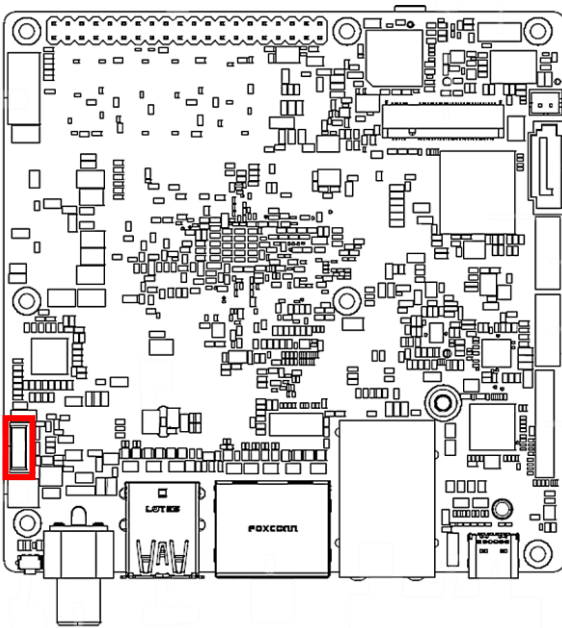

Pin	Signal	Pin	Signal
1	GND	2	RESET
3	GND	4	POWER S/W
5	GND	6	+5V

### 2.3.20 DC Terminal Block (Optional with Colay) (CN22)

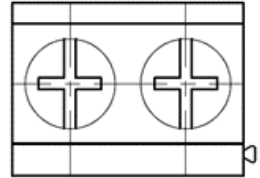
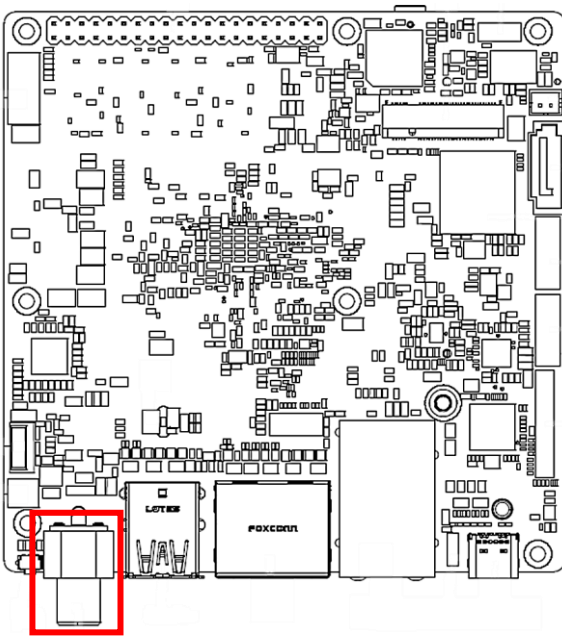

Pin	Signal	Pin	Signal
1	DC_IN	2	GND

### 2.3.21 Audio Wafer (CN23)

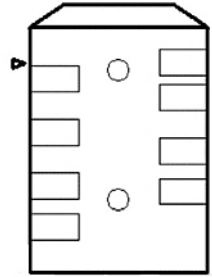
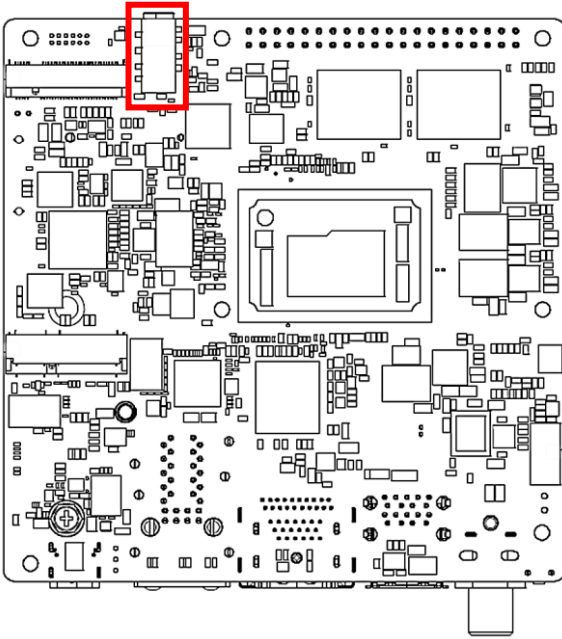

Pin	Signal	Pin	Signal
1	MIC_LR	2	GND
3	LOUT_R	4	NC
5	NC	6	AUDIO-JD
7	NC	8	LOUT_L

### 2.3.22 12V Connector (CN26)

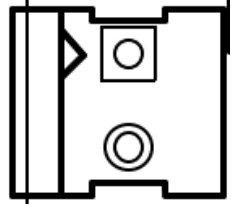
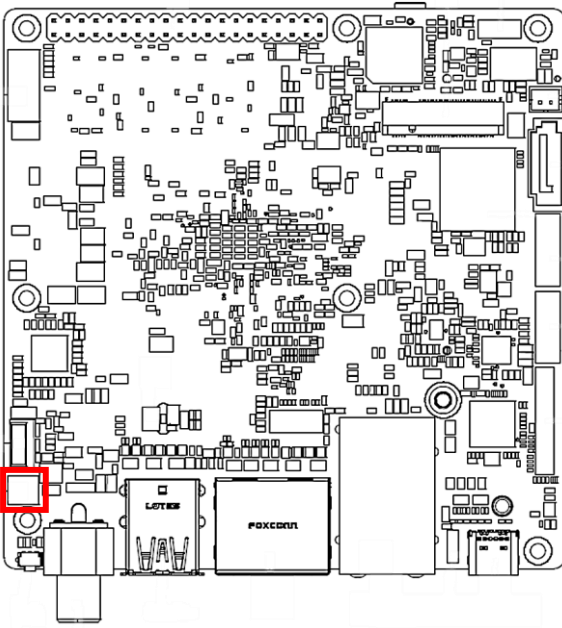

Pin	Signal	Pin	Signal
1	12V	2	GND

### 2.3.23 Fan Connector (J1)

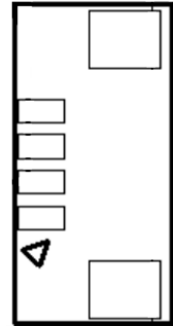
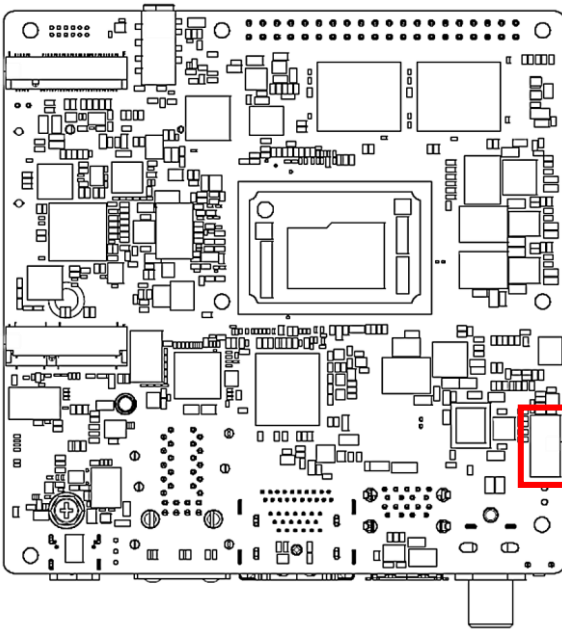

Pin	Signal	Pin	Signal
1	PWM	2	TACH
3	GND	4	12V

## 2.3.24 AT/ATX Mode (JP1)

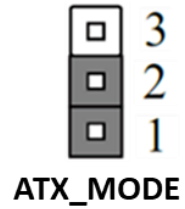
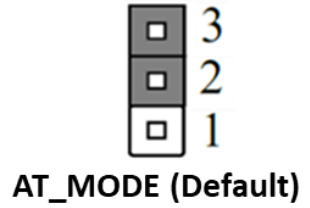
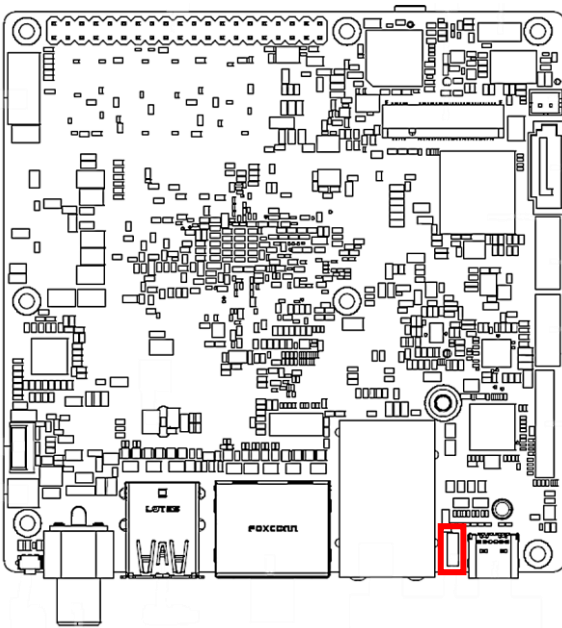

Pin	Signal	Pin	Signal
1	ATX_MODE	2	PWRBTN
3	AT_MODE	-	-

# Chapter 3

---

Software Installation

## 3.1 Linux Setup

---

The UP Squared Pro 7000 supports Linux operating systems (see Chapter 1 for specifications). For instructions on how to install a Linux OS onto your UP Squared Pro 7000, you can find several guides and tutorials in the wiki section of the UP Board website at <https://up-board.org> for both installing supported distributions as well as porting your own Linux build.

## 3.2 Windows Drivers Installation

---

Drivers for the UP Squared Pro 7000 can be downloaded from the UP Board website by following the link <https://up-board.org> and navigating to the Downloads section, then clicking on the UP Squared Pro 7000 to find all relevant drivers.

## 3.3 Dummy Driver Information

---

### 3.3.1 Dummy Driver Installation

---

The following instructions detail how to install the dummy driver for your UP Squared Pro 7000 (UPN-ADLN01).

#### Step 1 – Download UPNullDrv.msi.

 UPNullDrv.msi	10/17/2022 2:18 AM	Windows Installer Pa...	200 KB
---	--------------------	-------------------------	--------

**Step 2 – Click UPNullDrv.msi** and follow the steps as per the below images to install Driver.

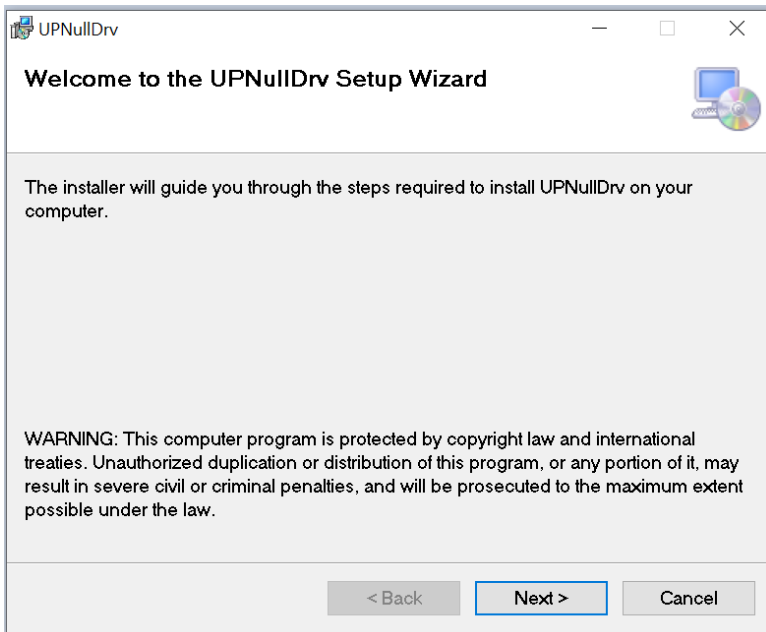

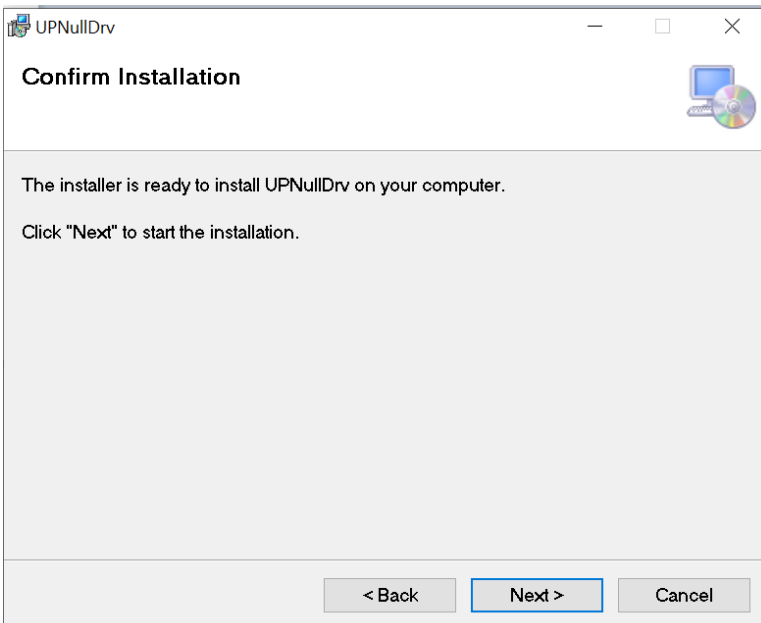
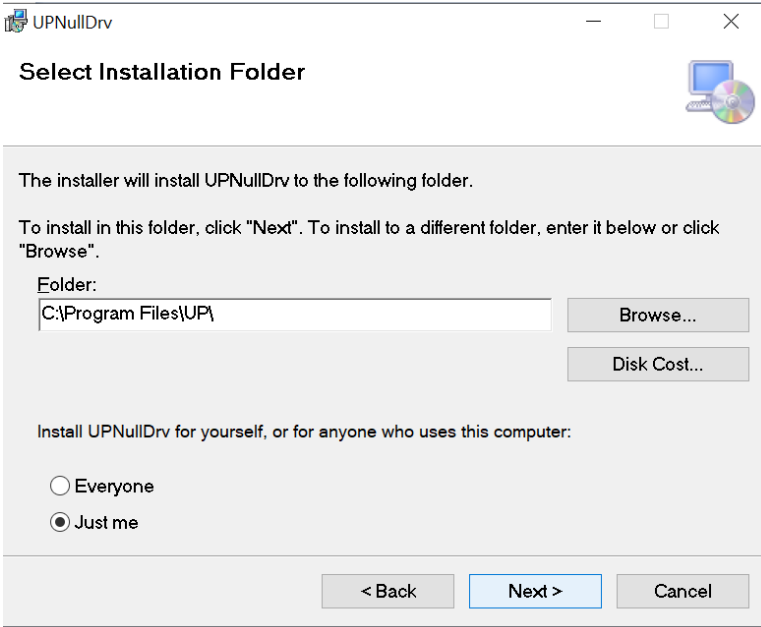

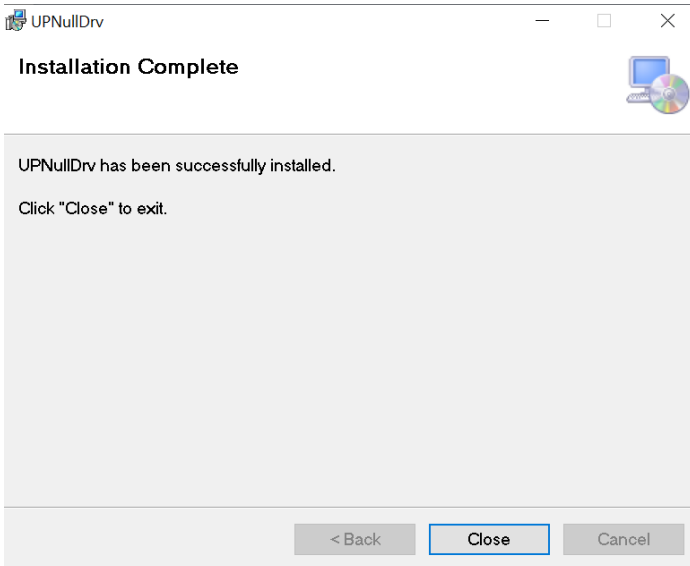
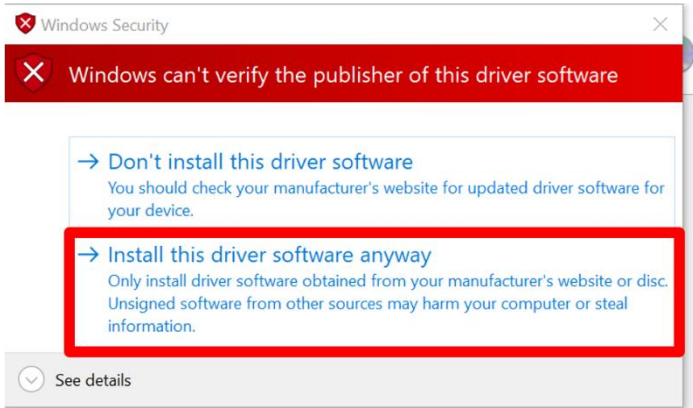

Once you have successfully installed the dummy driver, you will be able to locate it via your system's Device Manager, as shown below.

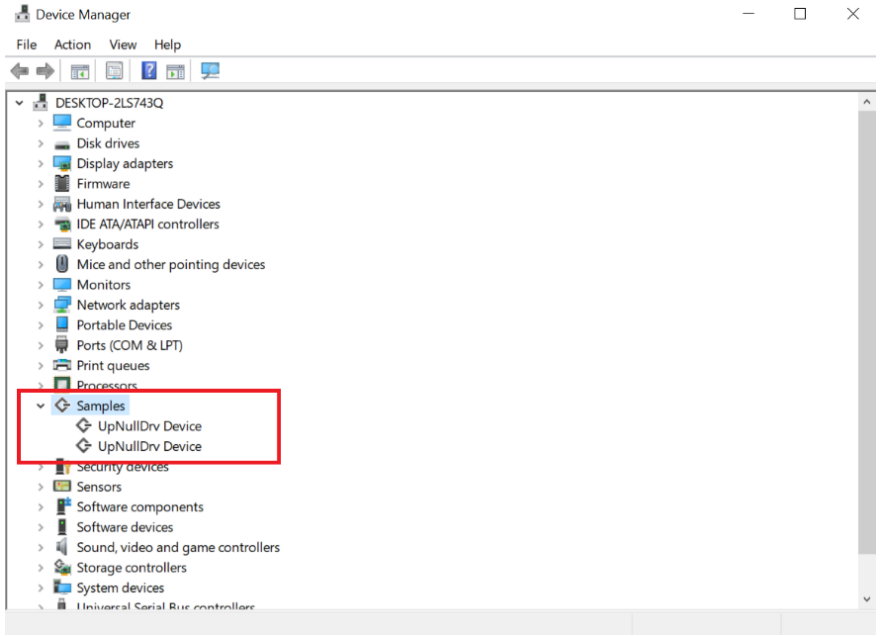

### 3.3.2 Uninstalling the Dummy Driver

Click `UPNullDrv.msi` to uninstall driver, then select **Remove UPNullDrv**.

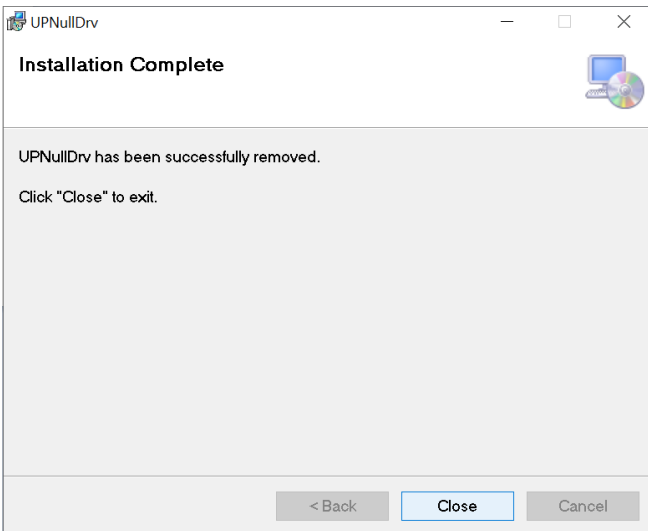
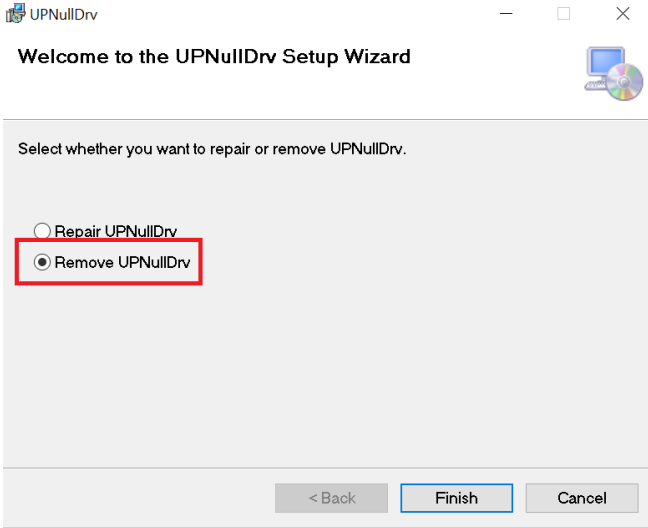

# Appendix A

---

UP Framework SDK Installation

## A.1 Introduction

---

This section provides instructions for the installation of the UP Framework SDK. Instructions are provided for Windows 10 and Windows IoT Core. You can download the latest version of UP Framework SDK from the UP community:

<https://downloads.up-community.org/download/up-sdk-for-windows-10-and-windows-iot/>

## A.2 Installation for Windows 10

---

### Step 1

Locate the downloaded file UpFrameworkSetup.msi and run the installer. Press “Next” to begin the setup process.

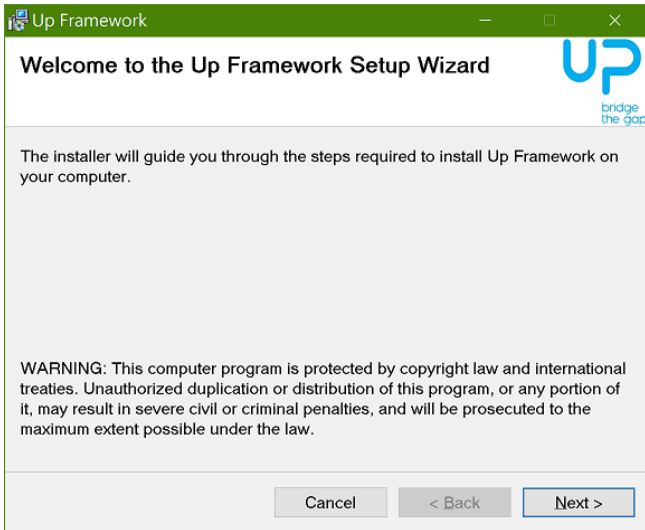

### Step 2

Select the installation folder. Default destination path is C:\Program Files(x86)\AAEON\  
 You may also choose to install the UP Framework SDK for all users or only the current user. Press "Next" to continue installation.

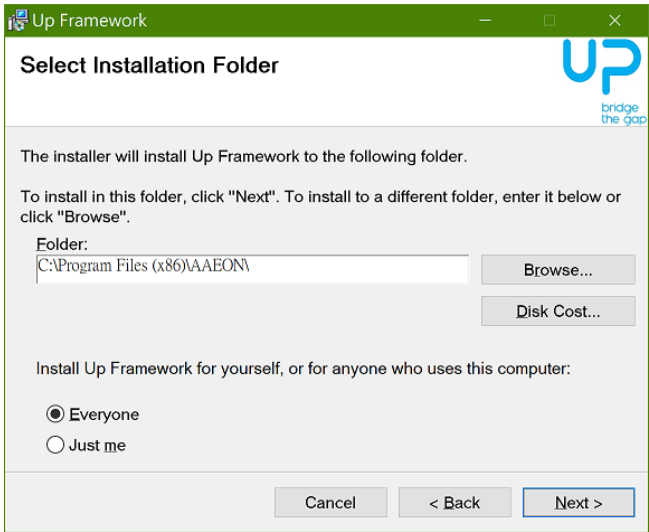

### Step 3

Press "Next" to confirm the installation.

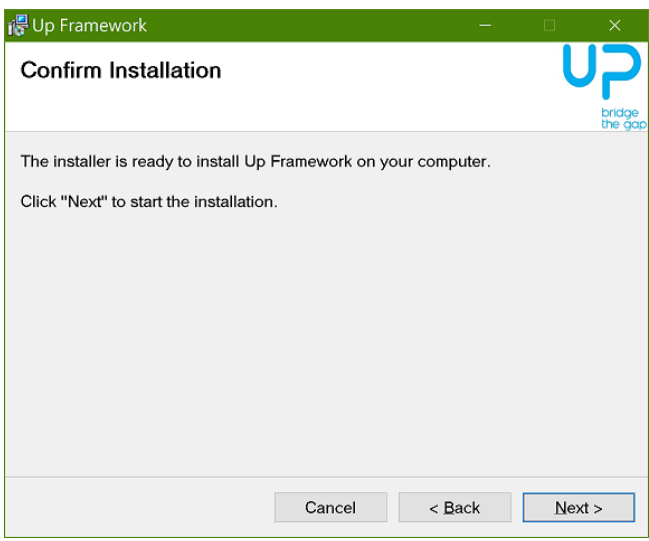

## Step 4

Press "Close" to exit once setup is complete.

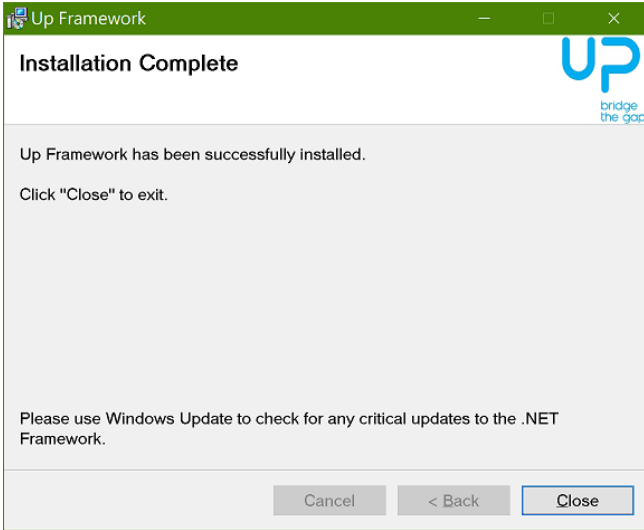

# Appendix B

---

Cables and Connectors

## B.1 Cables and Connectors

---

This table provides detailed information about the cables and connectors used by the UP Squared Pro 7000 (UPN-ADLN01). If you have any questions about the configuration of your board, please contact your AAEON sales representative.

Label	Mating Cable PN	Mating Cable Description
COM1	1701100180	(TF)COM Cable.D-SUB 9P(M).10P1.0mm Housing.15cm
COM2	1701100180	(TF)COM Cable.D-SUB 9P(M).10P1.0mm Housing.15cm
RTC	175011301K	(TF)Lithium Battery.CR2032H.3V.240mAH.w/cable 90mm.Battery power.BP-CR2032-M90-001