

SBC-656

Half Size Celeron CPU Card
With LCD, Ethernet & SSD

Copyright Notice

This document is copyrighted, 1999. All rights are reserved. The original manufacturer reserves the right to make improvements to the products described in this manual at any time without notice.

No part of this manual may be reproduced, copied, translated, or transmitted in any form or by any means without the prior written permission of the original manufacturer. Information provided in this manual is intended to be accurate and reliable. However, the original manufacturer assumes no responsibility for its use, nor for any infringements upon the rights of third parties which may result from its use.

Acknowledgements

AMD is a trademark of Advanced Micro Devices, Inc.

AMI is a trademark of American Megatrends, Inc.

Award is a trademark of Award Software International, Inc.

Cyrix is a trademark of Cyrix Corporation.

IBM, PC/AT, PS/2, and VGA are trademarks of International Business Machines Corporation.

Intel Celeron and Pentium II are trademarks of Intel Corporation.

Microsoft Windows® is a registered trademark of Microsoft Corp.

SMC is a trademark of Standard Microsystems Corporation.

RTL is a trademark of Realtek Semi-Conductor Co., Ltd.

C&T is a trademark of Chips and Technologies, Inc.

UMC is a trademark of United Microelectronics Corporation.

ITE is a trademark of Integrated Technology Express, Inc.

SiS is a trademark of Silicon Integrated Systems Corp.

VIA is a trademark of VIA Technology, Inc.

All other product names or trademarks are properties of their respective owners.

A Message to the Customer

AAEON Customer Services

Each and every AAEON product is built to the most exacting specifications to ensure reliable performance in the harsh and demanding conditions typical of industrial environments. Whether your new AAEON equipment is destined for the laboratory or the factory floor, you can be assured that your product will provide the reliability and ease of operation for which the name AAEON has come to be known.

Your satisfaction is our primary concern. Here is a guide to AAEON's customer services. To ensure you get the full benefit of our services, please follow the instructions below carefully.

Technical Support

We want you to get the maximum performance from your products. So if you run into technical difficulties, we are here to help. For the most frequently asked questions, you can easily find answers in your product documentation. These answers are normally a lot more detailed than the ones we can give over the phone.

So please consult this manual first. If you still cannot find the answer, gather all the information or questions that apply to your problem, and with the product close at hand, call your dealer. Our dealers are well trained and ready to give you the support you need to get the most from your AAEON products. In fact, most problems reported are minor and are able to be easily solved over the phone.

In addition, free technical support is available from AAEON engineers every business day. We are always ready to give advice on application requirements or specific information on the installation and operation of any of our products.

Product Warranty

AAEON warrants to you, the original purchaser, that each of its products will be free from defects in materials and workmanship for one year from the date of purchase.

This warranty does not apply to any products which have been repaired or altered by persons other than repair personnel authorized by AAEON, or which have been subject to misuse, abuse, accident or improper installation. AAEON assumes no liability under the terms of this warranty as a consequence of such events.

Because of AAEON's high quality-control standards and rigorous testing, most of our customers never need to use our repair service. If an AAEON product is defective, it will be repaired or replaced at no charge during the warranty period. For out-of-warranty repairs, you will be billed according to the cost of replacement materials, service time, and freight. Please consult your dealer for more details.

If you think you have a defective product, follow these steps:

1. Collect all the information about the problem encountered. (For example, CPU type and speed, AAEON products used, other hardware and software used, etc.) Note anything abnormal and list any on-screen messages you get when the problem occurs.
2. Call your dealer and describe the problem. Please have your manual, product, and any helpful information readily available.
3. If your product is diagnosed as defective, obtain an RMA (return material authorization) number from your dealer. This allows us to process your return more quickly.
4. Carefully pack the defective product, a fully-completed Repair and Replacement Order Card and a photocopy proof of purchase date (such as your sales receipt) in a shippable container. A product returned without proof of the purchase date is not eligible for warranty service.
5. Write the RMA number visibly on the outside of the package and ship it prepaid to your dealer.

Packing list

Before you begin installing your card, please make sure that the following materials have been shipped:

- 1 SBC-656 All-in-One Single Board Computer Card
- 1 Quick Installation Guide
- 1 Support CD contains the followings:
 - User's Manual (this manual in PDF file)
 - Ethernet drivers and utilities
 - VGA drivers and utilities
- 1 hard disk drive (IDE) interface cable
- 1 floppy disk drive interface cable
- 1 6 pins mini-DIN dual outlet adapter for PS/2 keyboard and mouse
- 1 parallel port adapter (26 pins) and COM2 adapter (for RS-232/422/485)
- 1 Accessory. for All Series Jumper
- 1 bag of screws and miscellaneous parts

If any of these items are missing or damaged, contact your distributor or sales representative immediately.

Notice

Dear Customer,

Thank you for purchasing the SBC-656 board. This user's manual is designed to help you to get the most out of the SBC-656, please read it thoroughly before you install and use the board. The product that you have purchased comes with an two-year limited warranty, but AAEMON will not be responsible for misuse of the product. Therefore, we strongly urge you to first read the manual before using the product.

To receive the latest version of the user manual, please visit our Web site at:

<http://www.aaeon.com.tw>

Contents

Chapter 1: General Information	1
Introduction	2
Features	3
Specifications	4
Board layout	7
Board dimensions	8
Chapter 2: Installation	9
Jumpers and connectors	10
Locating jumpers	12
Locating connectors	13
Setting jumpers	14
CPU installing and upgrading	15
Installing SDRAM (DIMMs)	17
Cache Memory	17
DOC address & CPU frequency ratio select SW1 (1, 2, 3, 4, 5, 6)	18
LCD clock signal & driving voltage select (J2)	20
Clear CMOS (J3)	21
COM2 RS-232/422/485 select (J4, J5)	22
Power connectors (PWR1)	23
CPU fan power connector (CN1)	24
IrDA connector (CN2, Pin 1~5)	25
Reset switch (CN2, Pin 6, 7)	26
External/internal speaker (CN2, Pin 8~11)	27
Hard drive LED (CN2, Pin 13, 14)	28
IDE hard drive connector (CN3)	29
Display connectors (CN13, CN6)	31
USB connector (CN7)	34
Keyboard and PS/2 mouse connector (CN8, CN11)	35
Parallel port connector (CN9)	36

Floppy drive connector (CN10)	37
100Base-Tx Ethernet connector (CN14)	40
Serial ports (CN15, CN12)	41
DiskOnChip socket (U19)	42
DiskOnChip (DOC) 2000 Installation	43
Chapter 3: Award BIOS Setup	45
Starting setup	46
Setup keys	47
Getting help	48
Main setup menu	49
Standard CMOS setup	51
BIOS features setup	52
CHIPSET features setup	53
Power management setup	54
PNP/PCI configuration setup	55
Load BIOS defaults / Load setup defaults	56
Integrated peripherals setup	57
Supervisor / User password	58
IDE HDD auto detection	60
Save & exit setup	61
Chapter 4: Flat Panel/CRT controller Display Drivers and Utilities	63
Software drivers	64
Hardware configuration	64
Necessary prerequisites	65
Before you begin	65
Windows 95	66
Driver installation	66
Windows NT 3.51	74
Driver installation	74

Windows NT 4.0	75
Driver installation	75
Chapter 5: Ethernet Software configuration	77
.....	77
Ethernet software configuration	78
Appendix A: Programming the Watchdog Timer	79
Appendix B: Installing PC/104 Modules	89
Installing PC/104 modules	90

General Information

This chapter gives background information on the mainboard.

Sections include:

- Board specifications
- Layout and dimensions

Introduction

The SBC-656 is an all-in-one Celeron processor based single board computer (SBC) with a PCI Flat Panel controller, a PCI 100Base-Tx Ethernet interface. When using an Intel Celeron processor, the SBC-656 achieves outstanding performance that surpasses any other SBC in its class. In addition, the onboard SSD interface supports M-systems DiskOnChip 2000 series, memory capacity from 4 MB to 1 GB.

Onboard features include two serial ports (one RS-232, one RS-232/422/485), one multi-mode parallel (ECP/EPP/SPP) port, connector for two USB (Universal Serial Bus) ports, a floppy drive controller, and a keyboard/PS/2 mouse interface. The built-in high speed PCI IDE controller supports Ultra DMA/33 mode. Up to two IDE devices can be connected, including large hard disks, CD-ROM drives, and tape backup drives, etc.

The SBC-656 also features power management to minimize power consumption. The board's watchdog timer can automatically reset the system or generate an interrupt in case the system stops due to a program bug or EMI.

Highly integrated SBC

The SBC-656 is a highly integrated SBC that combines, video, and network functions on a single computer board. It provides up to 1024 x 768 resolution @ 64K colors with on-chip 2MB SDRAM display memory. Major onboard devices adopt PCI technology to achieve outstanding computing performance making the SBC-656 one of the world's best and most powerful all-in-one Single Board Computer.

Features

- Supports Intel Celeron CPUs up to 533MHz
- Supports DiskOnChip (SSD) up to 1GB
- C&T 69000 LCD controller supports 36-bit TFT Panels
- 100Base-Tx Fast Ethernet
- Supports H/W status monitoring

Specifications

Standard SBC functions

- **CPU:** Intel Celeron 300~533MHz (With system bus frequency of 66MHz)
- **Bus interface:** ISA bus.
- **CPU socket:** 370 pins Socket
- **BIOS:** Award 256KB Flash BIOS
- **Chipset:** Intel 443BX
- **I/O chipset:** Winbond W83977TF with fully 16-bit I/O decoded
- **Memory :** Onboard one 168 pins DIMM sockets support up to 256Mbytes SDRAM
- **Enhanced IDE:** Supports up to two IDE devices. Supports Ultra DMA/33 mode with data transfer rate 33MB/Sec.
- **FDD interface:** Supports up to two floppy disk drives, 5.25" (360KB and 1.2MB) and/or 3.5" (720KB, 1.44MB, and 2.88MB)
- **Parallel port:** One bi-directional parallel port. Supports SPP, ECP, and EPP modes
- **Serial port:** One RS-232 and one RS-232/422/485 serial port. Ports can be configured as COM1, COM2, COM3, COM4, or disabled individually. Two 16C550 serial UARTs.
- **IR interface:** Supports one IrDA Tx/Rx header
- **KB/Mouse connector :** 6 pins mini-DIN connector supports PS/2 keyboard and mouse. Additional 5 pins header supports PC/AT keyboard for IPC applications
- **USB connectors:** 5 x 2 header onboard supports dual USB ports
- **Battery:** Lithium battery
- **Watchdog timer:** Can generate a system reset, NMI. Software selectable time-out interval (32 sec. ~ 254 min., 1 min./step)

- **DMA:** 7 DMA channels (8237 equivalent)
- **Interrupt:** 15 interrupt levels (8259 equivalent)
- **Power management:** I/O peripheral devices support power saving and doze/standby/suspend modes. APM 1.2 ocmpliant
- **H/W status monitoring:** Winbond W83781D H/W status monitoring IC supports power supply voltages, and temperatures monitoring

Flat Panel/CRT Interface

- **Chipset:** C&T 69000
- **Display memory:** 2MB SDRAM built in chip
- **Display type:** Supports non-interlaced CRT and LCD (TFT, DSTN, and Mono) displays. Can display both CRT and Flat Panel simultaneously
- **Resolution:** Up to 1024x768@64K colors

Ethernet Interface

- **Chipset:** Realtek RTL8139B 100Base-Tx Fast Ethernet controller
- **Ethernet interface :** Onboard 100Base-Tx RJ-45 connector

SSD Interface

- One 32 pins DIP socket supports M-Systems DiskOnChip 2000 series up to 1GB

Mechanical and environmental

- **Power supply voltage:** +5V (4.75V to 5.25V),
+12V (11.4V to 12.6V)
- **Power requirement:** +5V @ 4.1A(Celeron 300MHz)
- **Operating temperature:** 32 to 140° F (0 to 60° C)
- **Board Size:** 7.3"(L) x 4.8"(W) (185mm x 122mm)
- **Gross Weight:** 0.66 lb. (0.3 Kg)

Board layout



Board dimensions

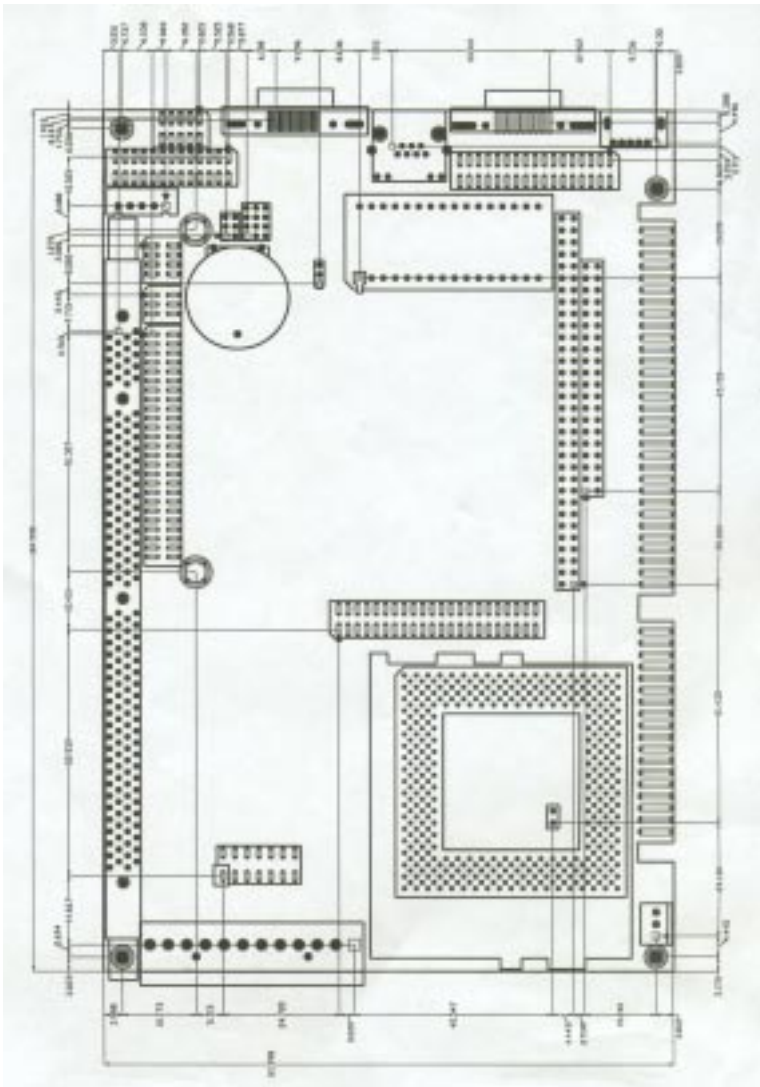

Installation

This chapter describes how to set up the main board hardware, including instructions on setting jumpers and connecting peripherals, switches, and indicators. Be sure to read all the safety precautions before you begin the installation procedure.

Jumpers and connectors

Connectors on the board link it to external devices such as hard disk drives, a keyboard, or floppy drives. In addition, the board has a number of jumpers that allow you to configure your system to suit your application.

The following tables list the function of each of the board's jumpers and connectors.

Jumpers

Label	Function
SW1 (2, 3)	DOC address select
SW1 (4, 5, 6)	CPU frequency ratio select
J2	LCD clock signal & driving voltage select
J3	Clear CMOS
J4	COM2 RS-232/422/485 select
J5	COM2 RS-232/422/485 select

Connectors

Label	Function
CN1	CPU fan power connector
CN2 (Pin 1~5)	IrDA connector
CN2 (Pin 6, 7)	Reset switch
CN2 (Pin 8, 9)	External speaker
CN2 (Pin 13, 14)	IDE drive LED
CN3	IDE hard drive connector
CN4	PC/104 connector
CN5	PC/104 connector
CN6	LCD display connector
CN7	USB connector
CN8	Internal keyboard connector
CN9	Parallel port connector
CN10	Floppy drive connector
CN11	Keyboard and PS/2 mouse connector
CN12	COM2 RS-232/422/485 serial port connector
CN13	VGA display connector
CN14	100Base-Tx Ethernet connector
CN15	COM1 RS-232 serial port connector
PWR1	Power connector

Locating jumpers

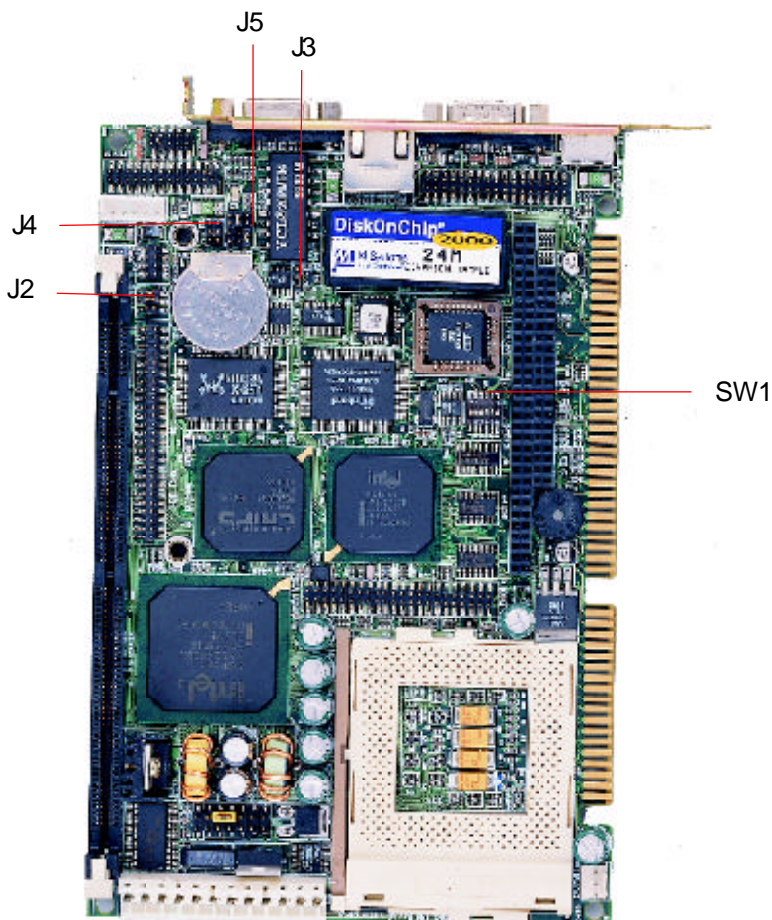

Locating connectors

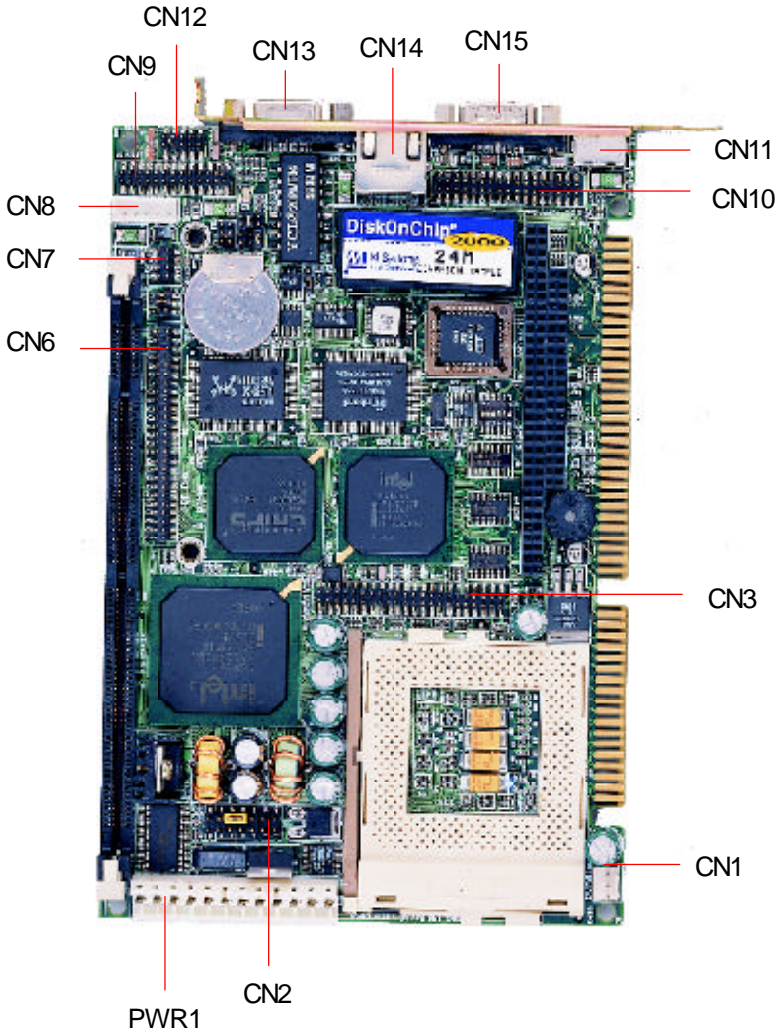

Setting jumpers

You can configure your card to match the needs of your application by setting jumpers. A jumper is the simplest kind of electric switch. It consists of two metal pins and a small metal clip (often protected by a plastic cover) that slides over the pins to connect them. To close a jumper you connect the pins with the clip. To open a jumper you remove the clip. Sometimes a jumper will have three pins, labeled 1, 2, and 3. In this case you would connect either pins 1 and 2 or 2 and 3.

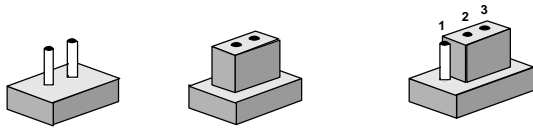

Open

Closed

Closed 2-3

The jumper settings are schematically depicted in this manual as follows:



Open

Closed

Closed 2-3

A pair of needle-nose pliers may be helpful when working with jumpers.

If you have any doubts about the best hardware configuration for your application, contact your local distributor or sales representative before you make any changes.

CPU installing and upgrading

You can upgrade to a more powerful Celeron CPU at any time. Simply remove the old CPU, install the new one, and set the jumpers for the new CPU speed.

Warning! *Always disconnect the power cord from your chassis when you are working on it. Do not make connections while the power is on as sensitive electronic components can be damaged by the sudden rush of power. Only experienced electronics personnel should open the system chassis.*



Caution! *Always ground yourself to remove any static charge before touching the system board. Modern electronic devices are very sensitive to static electric charges. Use a grounding wrist strap at all times. Place all electronic components on a static-dissipative surface or in a static-shielded bag when they are not in the chassis.*



Install a CPU in the ZIF socket

SBC-656 Series provides a Zero Insertion Force (ZIF) socket for easy CPU installation.

1. Make sure the ZIF socket lever is in the upright position. To raise the lever, pull it out to the side a little and raise it as far as it will go.
2. Place the CPU in the empty socket. Follow the instructions that came with the CPU. If you have no instructions, do the following: Carefully align the CPU so it is parallel to the socket and the notch on the corner of the CPU corresponds with the notch on the inside of the socket. Gently slide the CPU in. It should insert easily. If it doesn't, pull the lever up a little more.

3. Press the lever down. The plate will slide forward. You will feel some resistance as the pressure starts to secure the CPU in the socket. This normal and won't damage the CPU.

When the CPU is installed, the lever should snap into place at the side of the socket.

Note: To remove a CPU, pull the lever out to the side a little and raise it as far as it will go. Lift out the CPU chip.

When you install a new CPU, be sure to adjust the board settings, such as CPU type and CPU clock. **Improper settings may damage the CPU.**

Installing SDRAM (DIMMs)

System Memory

The upper edge of the SBC-656 contains one sockets for 168 pins dual inline memory module (DIMM). The socket uses 3.3 V unbuffered synchronous (SDRAM). DIMM is available in capacities of 16, 32, 64, 128, or 256 MB. The socket can be filled in the DIMM of any size, giving your SBC-656 single board computer between 16 and 256 MB of memory.

Memory Installation Procedures

To install DIMM, first make sure the two handles of the DIMM socket are in the "open" position. i.e. The handles remain outward. Slowly slide the DIMM module along the plastic guides on both ends of the socket. Then press the DIMM module right down into the socket, until you hear a click. This is when the two handles have automatically locked the memory module into the correct position of the DIMM socket. (See Figure below) To take away the memory module, just push both handles outward, and the memory module will be ejected by the mechanism in the socket.

Cache memory

Since the second level cache has been embedded into the Celeron CPU, you do not have to take care of either SRAM chips or SRAM modules. The built-in second level cache in the Celeron yields much higher performance than the external cache memories. The cache size in the Celeron CPU is either 128 KB.

DOC address & CPU frequency ratio select SW1 (1, 2, 3, 4, 5, 6)

DOC address select

The DiskOnChip 2000 occupies a 8KB window in the upper memory address range of D400 to DC00. You should ensure this does not conflict with any other device's memory address. SW1 (2, 3) controls the memory address of the Flash disk.

DOC address select SW1(2, 3)

	D400 *	D800	DC00	Disable
1				
2				
3				
4				
5				
6				

Note:

These addresses might conflict with the ROM BIOS of other peripheral boards. Please select the appropriate memory address to avoid memory conflicts.

CPU frequency ratio select

CPU core frequency = CPU frequency ratio (3~5.5) * External bus clock (66MHz)

CPU frequency ratio select SW1 (4, 5, 6)

3X		3.5X		4.0X	
1	<input type="checkbox"/>	1	<input type="checkbox"/>	1	<input type="checkbox"/>
2	<input type="checkbox"/>	2	<input type="checkbox"/>	2	<input type="checkbox"/>
3	<input type="checkbox"/>	3	<input type="checkbox"/>	3	<input type="checkbox"/>
4	<input checked="" type="checkbox"/>	4	<input checked="" type="checkbox"/>	4	<input checked="" type="checkbox"/>
5	<input checked="" type="checkbox"/>	5	<input checked="" type="checkbox"/>	5	<input type="checkbox"/>
6	<input checked="" type="checkbox"/>	6	<input checked="" type="checkbox"/>	6	<input checked="" type="checkbox"/>
4.5X *		5X		5.5X	
1	<input type="checkbox"/>	1	<input type="checkbox"/>	1	<input type="checkbox"/>
2	<input type="checkbox"/>	2	<input type="checkbox"/>	2	<input type="checkbox"/>
3	<input type="checkbox"/>	3	<input type="checkbox"/>	3	<input type="checkbox"/>
4	<input checked="" type="checkbox"/>	4	<input checked="" type="checkbox"/>	4	<input checked="" type="checkbox"/>
5	<input checked="" type="checkbox"/>	5	<input checked="" type="checkbox"/>	5	<input checked="" type="checkbox"/>
6	<input checked="" type="checkbox"/>	6	<input checked="" type="checkbox"/>	6	<input checked="" type="checkbox"/>

* default









Note:

Most Celeron CPUs' frequency ratio are pre-locked within the CPUs. These CPUs run at fixed speed (frequency) regardless of the configurations listed above.

If the CPU you are using requires higher ratio than 5.5X, it is most likely pre-locked.

LCD clock signal & driving voltage select (J2)

You can select the LCD connector CN6 driving voltage & control signal by setting J2. The configurations are as follows:

LCD clock signal & driving voltage select (J2)		
	ASHF CLK / +5V	ASHFCLK / +3.3V
J2	5 3 1 <input type="radio"/>  <input type="radio"/>  6 4 2	5 3 1 <input type="radio"/>   <input type="radio"/> 6 4 2
		SHFCLK / +5V
	5 3 1  <input type="radio"/> <input type="radio"/>  6 4 2	5 3 1  <input type="radio"/>  <input type="radio"/> 6 4 2

*default



Clear CMOS (J3)

You can connect an external jumper cap or switch to clear CMOS.

Clear CMOS procedure:

1. Disconnect all power source.
2. Move J3 from 1-2 to 2-3 for few seconds.
3. Move J3 back to 1-2.

Clear CMOS (J3)







	Protect*	Clear CMOS
J3	1 2 3  ○	1 2 3 ○ 

*default

COM2 RS-232/422/485 select (J4, J5)

The SBC-656 COM2 serial port can be selected as RS-232, RS-422, or RS-485 by setting J4 & J5.

COM2 Select (J4, J5)

	RS-232*	RS-422	RS-485
J4	1 3 5  2 4 6	1 3 5  2 4 6	1 3 5  2 4 6
J5	1 4 7 10  3 6 9 12	1 4 7 10  3 6 9 12	1 4 7 10  3 6 9 12

*default

Power connectors P8 & P9 (PWR1)

In single board computer (non-passive backplane) application. You will need to connect the power directly to the SBC-656 board using PWR1. This connector is fully compatible with the standard PC PS/2 power supply connector, P8 & P9. See the following table for its pin assignments:

Power connector pin assignments (PWR1)

Pin (P8)	Signal	Pin (P9)	Signal
1	GND	1	+5V
2	GND	2	+5V
3	-12V	3	+5V
4	+12V	4	-5V
5	+5V	5	GND
6	N.C.	6	GND

Power connector pin assignments (PWR1)

Pin (P8)	Color	Pin (P9)	Color
1	Black	1	Red
2	Black	2	Red
3	Blue	3	Red
4	Yellow	4	White
5	Red	5	Black
6	Orange	6	Black

CPU fan power connector (CN1)

The SBC-656 onboard offer +12V power for the CPU cooling fan. Plug in the fan cable onto the 3 pins fan power connector onboard. The fan connector is marked CN1.

CPU fan power connector (CN1)

Pin	Signal
1	GND
2	+12V
3	Fan speed sense

IrDA connector (CN2, Pin 1~5)

The IrDA connector (CN2, Pin 1~5) can be configured to support wireless infrared module, with this module and application software such as laplink or Win95 Direct Cable connection, user can transfer files to or from laptops, notebooks, PDA and printers. This connector supports HPSIR (115.2Kbps, 2 meters) and ASK-IR (56Kbps).

Install infrared module onto IrDA connector and enable infrared function from BIOS setup. Make sure to have correct orientation when you plug onto IrDA connector CN2 (Pin 1~5).

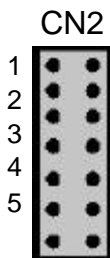

IrDA connector (CN2, Pin1~5)

Pin	Signal
1	Vcc
2	FIRRx
3	IRRx
4	GND
5	IRTx

Reset switch (CN2, Pin6, 7)

You can connect an external switch to easily reset your computer. This switch restarts your computer as if you had turned off the power, then turned it back on.

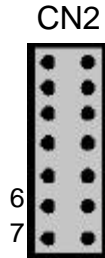

Reset switch (CN2, Pin6, 7)

Pin	Function
6	RST-IN
7	GND

External/internal speaker (CN2, Pin 8~11)

The CPU card has its own buzzer. You can also connect to the external speaker on your computer chassis. Pin assignments for CN2 (Pin8~11) are shown below:

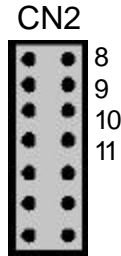

External speaker (CN2, Pin 8~11)

Pin	Function
8	Vcc (For external speaker use)
9	N/C
10	BZ_IN*
11	BUZZ*

* default

For external speaker connection :

Remove the default jumper cap from the pin 10~11 away.

(+) : Please connect to pin 8

(-) : Please connect to pin 11

Hard drive LED (CN2, Pin 13, 14)

You can connect an LED to indicate when an IDE device is in use. The pin assignments for this connector are as follows:

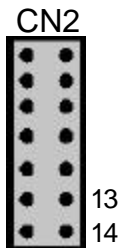

Hard drive LED (CN2, Pin 13, 14)

Pin	Function
13	HD-LED+
14	HD-LED-

IDE hard drive connector (CN3)

You can attach up to two Enhanced Integrated Device Electronics hard disk drives to the SBC-656's CN3. The SBC-656's IDE controller uses a PCI local bus interface. This advanced interface supports faster data transfer and allows the IDE hard drive to exceed 528 MB.

Connecting the hard drive

Connecting drives is done in a daisy-chain fashion and requires one of two cables, depending on the drive size. 1.8" and 2.5" drives need a 1 x 44-pin to 2 x 44-pin flat cable connector, 3.5" drives use a 1 x 44-pin to 2 x 40-pin connector.

Wire number 1 on the cable is normally red or blue, and the other wires are usually gray.

1. Connect one end of the cable to CN3. Make sure that the red (or blue) wire corresponds to pin 1 on the connector, which is labeled on the board (on the right side).
2. Plug the other end of the cable to the Enhanced IDE hard drive, with pin 1 on the cable corresponding to pin 1 on the hard drives. (see your hard drive's documentation for the location of the connector).

Connect a second drive as described above.

Unlike floppy drives, IDE hard drives can connect to either end of the cable. If you install two drives, you will need to set one as the master and the other one as the slave by using jumpers on the drives. If you install just one drive, set it as the master.

IDE hard drive connector (CN3)

IDE hard drive connector (CN3)			
Pin	Signal	Pin	Signal
1	IDE RESET	2	GND
3	DATA 7	4	DATA 8
5	DATA 6	6	DATA 9
7	DATA 5	8	DATA 10
9	DATA 4	10	DATA 11
11	DATA 3	12	DATA 12
13	DATA 2	14	DATA 13
15	DATA 1	16	DATA 14
17	DATA 0	18	DATA 15
19	SIGNAL GND	20	N/C
21	N/C	22	GND
23	IO WRITE	24	GND
25	IO READ	26	GND
27	IO CHANNEL READY	28	ALE
29	N/C	30	GND
31	IRQ14	32	IOCS16
33	ADDR 1	34	N/C
35	ADDR 0	36	ADDR 2
37	HARD DISK SELECT 0	38	HARD DISK SELECT 1
39	IDE ACTIVE	40	MGND
41	Vcc	42	MVcc
43	GND	44	N/C

Display connectors (CN13, CN6)

The SBC-656's PCI SVGA interface can drive conventional CRT displays and is capable of driving a wide range of flat panel displays, including electroluminescent (EL), gas plasma, passive LCD, and active LCD displays. The board has two connectors to support these displays, one for standard CRT VGA monitors and one for flat panel displays.

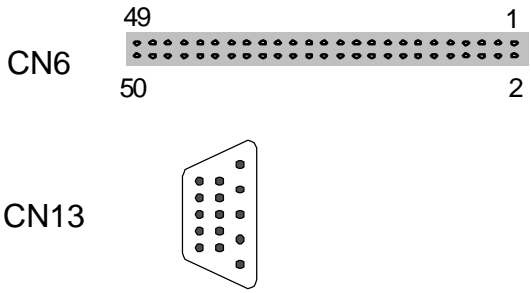

VGA display connector (CN13)

VGA display connector (CN13)

Pin	Signal
1	Red video
2	Green video
3	Blue video
4	Not used
5	GND
6	Red return (GND)
7	Green return (GND)
8	Blue return (GND)
9	Key (on pin)
10	Sync return (GND)
11	Monitor ID (not used)
12	Monitor ID
13	Horizontal sync
14	Vertical sync
15	Not used

LCD display connector (CN6)

CN6 is a 50-pin, dual-in-line header used for flat panel displays.

When the SBC-656's power is applied, the control signal is low until just after the relevant flat panel signals are present.

Configuration of the VGA interface is done completely via the software utility. You do not have to set any jumpers.

LCD display connector (CN6)

Pin	Signal	Pin	Signal
1	+12 V _{DC}	2	+12 V _{DC}
3	GND	4	GND
5	+5 V _{DC}	6	+5 V _{DC}
7	ENAVEE	8	GND
9	P0	10	P1
11	P2	12	P3
13	P4	14	P5
15	P6	16	P7
17	P8	18	P9
19	P10	20	P11
21	P12	22	P13
23	P14	24	P15
25	P16	26	P17
27	P18	28	P19
29	P20	30	P21
31	P22	32	P23
33	P24	34	P25
35	SHF CLK	36	FLM (V SYS)
37	M	38	LP (H SYS)
39	GND	40	ENABKL
41	P26	42	P27
43	P28	44	P29
45	P30	46	P31
47	P32	48	P33
49	P34	50	P35

USB connector (CN7)

The SBC-656 provides two USB (Universal Serial Bus) interfaces, which give complete plug and play, hot attach/detach for up to 127 external devices. The USB interfaces comply with USB specification Rev. 1.0, and can be disabled in the system BIOS setup.

USB connector (CN7)

Pin	Function	Pin	Function
1	Vcc	2	GND
3	USBDO-	4	GND
5	USBDO+	6	USBD1+
7	GND	8	USBD1-
9	GND	10	Vcc

Keyboard and PS/2 mouse connector (CN8, CN11)

The SBC-656 provides a keyboard connector which supports PS/2 keyboard and mouse. In most cases, especially in embedded applications, a keyboard is not used. The standard PC/AT BIOS will report an error or fail during power-on-self-test (POST) after a reset if the keyboard is not present. The mainboard BIOS Advanced setup menu allows you to select "Present" or "Absent" under the "System Keyboard" section. This allows no-keyboard operation in embedded system applications without the system halting under POST (power-on-self-test).

Keyboard and PS/2 mouse connector (CN11) (Mini-DIN 6 pins)

Pin	Signal
1	KB DATA
2	MS DATA
3	GND
4	Vcc
5	KB CLOCK
6	MS CLOCK

Internal keyboard connector (CN8)

Pin	Signal
1	KB_CLOCK
2	KB_DATA
3	N.C.
4	GND
5	Vcc

Parallel port connector (CN9)

Normally, the parallel port is used to connect the board to a printer. The SBC-656 includes an onboard parallel port, accessed through CN9, a 26-pin flat-cable connector. You need an adapter cable if you use a traditional DB-25 connector. The cable has a 26-pin connector on one end and a DB-25 connector on the other.

Parallel port IRQ

The SBC-656 supports one parallel port. The port is designated as LPT1 and can be disabled or changed to LPT2 or LPT3 in the system BIOS setup.

Parallel port connector table (CN9)

Parallel port connector (CN9)			
Pin	Signal	Pin	Signal
1	/STROBE	2	\AUTOFD
3	DO	4	ERR
5	D1	6	\INIT
7	D2	8	\SLCTINI
9	D3	10	GND
11	D4	12	GND
13	D5	14	GND
15	D6	16	GND
17	D7	18	GND
19	\ACK	20	GND
21	BUST	22	GND
23	PE	24	GND
25	SLCT	26	N/C

Floppy drive connector (CN10)

You can attach up to two floppy drives to the mainboard controller. You can use any combination of 5.25" (360 KB and 1.2 MB) and/or 3.5" (720 KB, 1.44 MB, and 2.88 MB) drives.

A 34-pin daisy-chain drive connector cable is required for a dual-drive system. On one end of the cable is a 34-pin flat-cable connector. On the other end are two sets of floppy disk drive connectors. Each set consists of a 34-pin flat-cable connector (usually used for 3.5" drives) and a printed-circuit board connector (usually used for 5.25" drives).

Wire number 1 on the cable is normally red or blue, and the other wires are usually gray.

Connecting the floppy drive

1. Plug the 34-pin flat-cable connector into CN10. Make sure that the red or blue wire corresponds to pin 1 on the connector.
2. Attach the appropriate connector on the other end of the cable to the floppy drive(s). You can use only one connector in the set. The set on the end (after the twist in the cable) connects to the A: drive. The set in the middle connects to the B: drive.
3. If you are connecting a 5.25" floppy drive, line up the slot in the printed circuit board with the blocked-off part of the cable connector.

If you are connecting a 3.5" floppy drive, you may have trouble determining which pin is pin number 1. Look for a number printed on the circuit board indicating pin number 1. Also, the connector on the floppy drive connector may have a slot. When the slot is up, pin number 1 should be on the right. Check the documentation that came with the drive for more information.

If you desire, connect the B: drive to the connectors in the middle of the cable as described above.

Floppy drive connector (CN10)

Floppy drive connector (CN10)

Pin	Signal	Pin	Signal
1	GND	2	DENSITY SELECT
3	GND	4	N/C
5	GND	6	DRIVE TYPE
7	GND	8	INDEX
9	GND	10	MOTOR 0
11	GND	12	DRIVE SELECT 1
13	GND	14	DRIVE SELECT 2
15	GND	16	MOTOR 1
17	GND	18	DIRECTION
19	GND	20	STEP
21	GND	22	WRITE DATA
23	GND	24	WRITE GATE
25	GND	26	TRACK 0
27	GND	28	WRITE PROTECT
29	GND	30	READ DATA
31	GND	32	HEAD DELECT
33	GND	34	DISK CHANGE

100Base-Tx Ethernet connector (CN14)

This 100Base-Tx Ethernet connector CN14 is a standard RJ-45 connector.

The onboard Realtek RTL8139B fast Ethernet controller supports 10Mb/s and 100 Mb/s N-way auto-negotiation operation.

Serial ports (CN15, CN12)

The SBC-656 offers two serial ports, one RS-232 (CN15) and one RS-232/422/485 (CN12). These ports allow you to connect them to serial devices (mouse, printers, etc.).

COM2 RS-232/422/485 serial ports (CN12)

COM2 RS-232/422/485 serial port (CN2)

	PIN	SIGNAL	PIN	SIGNAL
COM2	1	DCDB (422TXD-/485DATA-)	6	DSRB
	2	RXDB (422RXD+)	7	RTSB
	3	TXDB (422TXD+/485DATA+)	8	CTSB
	4	DTRB (422RXD-)	9	RIB
	5	GND	10	N.C.

DiskOnChip socket (U19)

The DiskOnChip 2000 family of products provides a single chip solid-state flash disk in a standard 32 pins DIP package. The DiskOnChip 2000 is a solid-state disk with no moving parts, resulting in a significant reduction in power consumption and an increase in reliability. The DiskOnChip is a small plug and play Flash disk. It is easy to use. And it saves integration overhead.

The DiskOnChip 2000 family of products is available in capacities ranging from up to 1GB, unformatted. In order to manage the disk, the DiskOnChip 2000 includes the TrueFFS, M-Systems Flash File System proprietary software. The DiskOnChip 2000 package is pin-to-pin compatible with a standard 32-pin EPROM device.

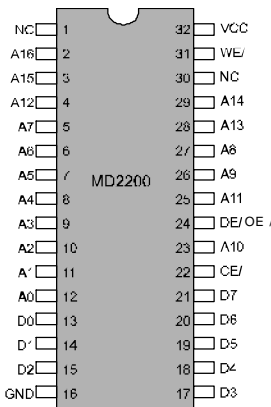

pin Name	Description	Pin Number	Direction	Note
A0-A12	Address bus	4-12,23,25-27	Inputs	
A13-A16	Address bus	2,3,28,29	Inputs	1
D0-D7	Data bus	13-15,17-21	I/O	
CE/	Chip Enable	22	Input	
OE/	Output Enable	24	Input	
WE/	Write Enable	31	Input	
NC	Not connected	1,30		2
VCC	Power	32		
GND	Ground	16		

Note 1: Pins A13 through A16 are not used by the MD2200. They are kept for socket backward compatibility with ED 1100 (DiskOnChip 1000)

Note 2: Pins 1 and 30 are not used by MD2200

DiskOnChip (DOC) 2000 Installation

When the DOC is installed correctly, a DOC will work like an HDD or an FDD. To install the DOC on the SBC-656, follow the instructions below:

1. Plug the DOC into the socket. Make sure pin 1 of the DOC is aligned with pin 1 of the socket.
2. Push the DOC into the socket until it is firmly seated in the socket.

Caution: the DOC may be permanently damage if it is installed incorrectly.

3. Set the jumper for the memory address of the DOC.

Note:

The memory shadow function sometimes will create conflicts with the memory window. You should disable the memory shadow from the BIOS SETUP if the DOC cannot be accessed.

Configure DOC as a boot device

To configure a DOC as a boot drive, you should copy the operating system files onto the DOC. The following procedure is an example of the initialization process.

1. Install a DOC into your system.
2. Insert a bootable floppy disk in drive A: and boot the system.
3. At the DOS prompt, type **SYS C:** to transfer the DOS system files to the DOC (assuming the DiskOnChip is installed as drive C:). Reboot the system.
4. Go to the BIOS Setup Utility by hitting the key. Set the type of Primary Master or C: Drive as *Not Installed*.
5. Remove the floppy disk from the drive A: and leave the BIOS Setup Utility. The system should boot from the DOC.

Award BIOS Setup

This chapter describes how to configure the BIOS for the system.

Starting setup

The Award BIOS is immediately activated when you first turn on the computer. The BIOS reads system configuration information in CMOS RAM and begins the process of checking out the system and configuring it through the power-on self test (POST).

When these preliminaries are finished, the BIOS seeks an operating system on one of the data storage devices (hard drive, floppy drive, etc.). The BIOS launches the operating system and hands control of system operations to it.

During POST, you can start the Setup program in one of two ways:

1. By pressing Del immediately after switching the system on, or
2. By pressing Del or pressing Ctrl-Alt-Esc when the following message appears briefly at the bottom of the screen during POST:

TO ENTER SETUP BEFORE BOOT PRESS DEL KEY

If the message disappears before you respond and you still wish to enter Setup, restart the system to try again by turning it OFF then ON or pressing the RESET button on the system case. You may also restart by simultaneously pressing Ctr-Alt-Del. If you do not press the keys at the correct time and the system does not boot, an error message appears and you are again asked to

PRESS F1 TO CONTINUE, DEL TO ENTER SETUP

Setup keys

These keys help you navigate in Setup:

Up arrow	Move to previous item
Down arrow	Move to next item
Left arrow	Move to the item in the left hand
Right arrow	Move to the item in the right hand
Esc	Main Menu: Quit and not save changes into CMOS RAM Other pages: Exit current page and return to Main Menu
PgDn/+	Increase the numeric value or make changes
PgDn/-	Decrease the numeric value or make changes
F1	General help, only for Status Page Setup Menu and Option Page Setup Menu
F2	Change color from total 16 colors. F2 to select color forward, Shift-F2 to select color backward
F3	Calendar, only for Status Page Setup Menu
F4	Reserved
F5	Restore the previous CMOS value from CMOS, only for Option Page Setup Menu
F6	Load the default CMOS RAM value from BIOS default table, only for Option Page Setup Menu
F7	Load the default
F8	Reserved
F9	Reserved
F10	Save all the CMOS changes, only for Main Menu

Getting help

Press F1 to pop up a small help window that describes the appropriate keys to use and the possible selections for the highlighted item. To exit the Help Window press Esc or the F1 key again.

In Case of Problems

If, after making and saving system changes with Setup, you discover that your computer no longer is able to boot, the **Award-BIOS** supports an override to the CMOS settings that resets your system to its default configuration.

You can invoke this override by immediately pressing Insert; when you restart your computer. You can restart by either using the ON/OFF switch, the RESET button or by pressing Ctrl-Alt-Delete.

The best advice is to alter only settings that you thoroughly understand. In particular, do not change settings in the Chipset screen without a good reason. The Chipset defaults have been carefully chosen by Award Software or your system manufacturer for the best performance and reliability. Even a seemingly small change to the Chipset setup may causing the system to become unstable.

Main setup Menu



Standard CMOS	Options in the original PC AT-compatible BIOS.
BIOS Features	Award Software enhanced BIOS options.
Chipset Features	Options specific to your system chipset.
Power Management	Advanced Power Management (APM) options.
PnP/PCI Configuration	Plug and Play standard and PCI Local Bus configuration options.
Integrated Peripherals	I/O subsystems that depend on the integrated peripherals controller in your system.
Supervisor/User Password Setting	Change, set, or disable a password. In BIOS versions that allow separate user and supervisor passwords, only the supervisor password permits access to Setup. The user password generally allows only power-on access.
IDE HDD Auto Detection	Automatically detect and configure IDE hard disk parameters.

Load BIOS Defaults	BIOS defaults are factory settings for the most stable, minimal-performance system operations.
Load Setup Defaults	Setup defaults are factory settings for optimal-performance system operations.
Save & Exit Setup	Save settings in nonvolatile CMOS RAM and exit Setup.
Exit Without Save	Abandon all changes and exit Setup.

Standard CMOS setup



When you choose the STANDARD CMOS SETUP option from the INITIAL SETUP SCREEN menu, the screen below is displayed.

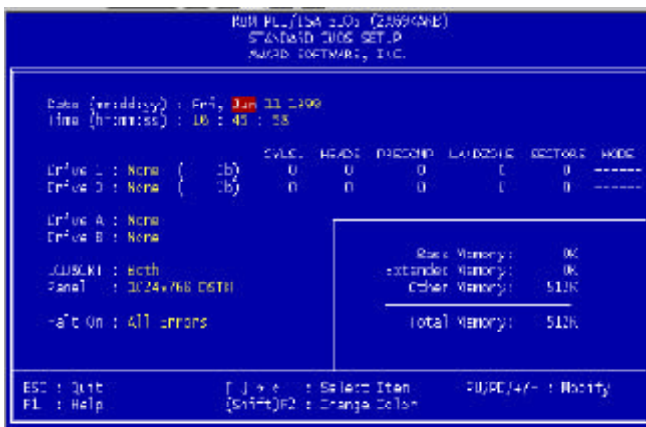

BIOS features setup



By choosing the BIOS FEATURES SETUP option from the INITIAL SETUP SCREEN menu, the screen below is displayed.



CHIPSET features setup



By choosing the CHIPSET FEATURES SETUP option from the INITIAL SETUP SCREEN menu, the screen below is displayed.

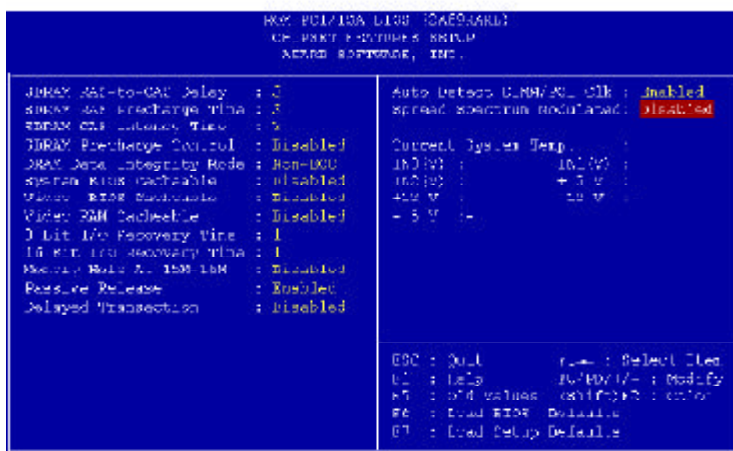

Power management setup



By choosing the POWER MANAGEMENT option from the INITIAL SETUP SCREEN menu, the screen below is displayed.

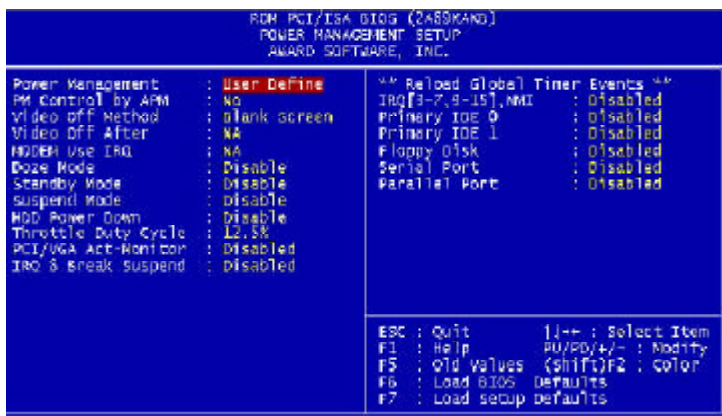

PNP/PCI configuration setup



By choosing the PNP/PCI CONFIGURATION SETUP option from the initial SETUP SCREEN menu, the screen below is displayed.



Load BIOS defaults / Load setup defaults

LOAD BIOS DEFAULTS loads the default system values directly from ROM. The BIOS DEFAULTS provides the most stable settings, though they do not provide optimal performance. LOAD SETUP DEFAULTS, on the other hand, provides for maximum system performance. If the stored record created by the setup utility becomes corrupted (and therefore unusable), BIOS defaults will load automatically when you turn the system on.

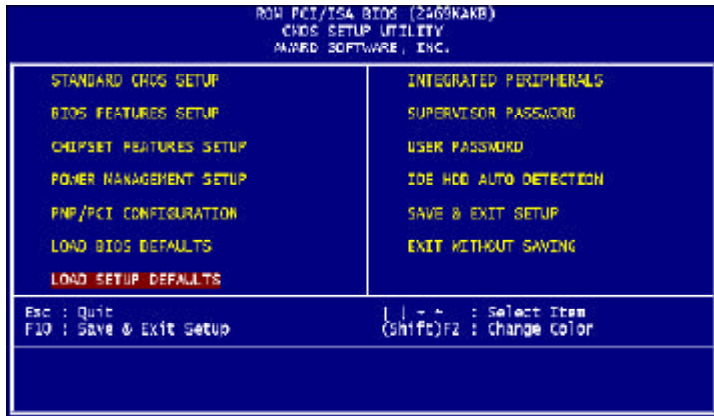

Integrated peripherals setup



By choosing the INTEGRATED PERIPHERALS option from the initial SETUP SCREEN menu, the screen below is displayed.

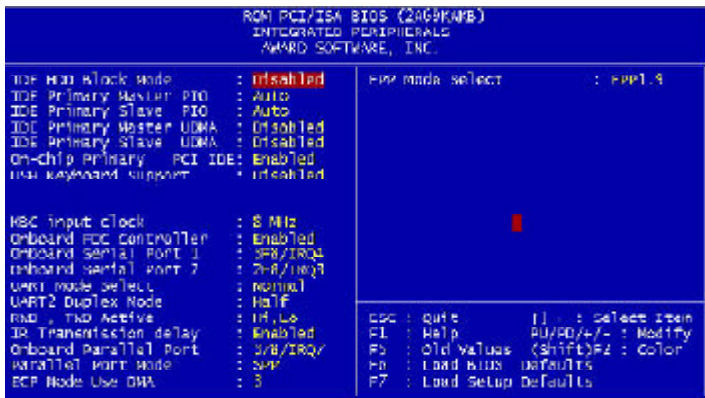

Supervisor / User password

You can set either SUPERVISOR or USER PASSWORD, or both of them. The difference between the two is that the supervisor password allows unrestricted access to enter and change the options of the setup menus, while the user password only allows entry to the program, but not modify options.



When you select this function, a message appears at the center of the screen:

ENTER PASSWORD:

Type the password, up to eight characters, and press Enter. Typing a password clears any previously entered password from CMOS memory.

Now the message changes:

CONFIRM PASSWORD:

Again, type the password and press Enter.

To abort the process at any time, press Esc.

In the Security Option item in the BIOS Features Setup screen, select System or Setup:

System Enter a password each time the system boots and when ever you enter Setup.

Setup Enter a password when ever you enter Setup.

***NOTE:** To clear the password, simply press Enter when asked to enter a password. Then the password function is disabled.*

IDE HDD auto detection

The IDE HDD AUTO DETECTION utility can automatically detect the IDE hard disk installed in your system. You can use it to self-detect and/or correct the hard disk type configuration. You need to repeat the setup for each of the IDE combinations:



Save & exit setup

If you select this option and press <ENTER>, the values entered in the setup utility will be recorded in the chipset's CMOS memory. The microprocessor will check this every time you turn your system on and compare this to what it finds as it checks the system. This record is required for the system to operate.



Flat Panel/CRT Controller Display Drivers and Utilities

This chapter provides information about:

- Driver types and installation

Software drivers

This chapter describes the operation and installation of the display drivers supplied on the *Supporting CD-ROM* that are shipped with your product.

The onboard VGA adapter is based on the CHIPS VGA Flat Panel/CRT controller and is fully IBM VGA compatible. This controller offers a large set of extended functions and higher resolutions. If you intend to use your VGA adapter in standard VGA modes only, you do not need to install any of these drivers. Since your VGA adapter is fully compatible, it does not require any special drivers to operate in standard modes.

The purpose of the enclosed software drivers is to take advantage of the extended features of the CHIPS VGA Flat Panel/CRT controller.

Hardware configuration

Some of the high-resolution drivers provided in this package will work only in certain system configurations. If a driver does not display correctly, try the following:

1. Change the display controller to CRT-only mode, rather than flat panel or simultaneous display mode. Some high-resolution drivers will display correctly only in CRT mode.
2. If a high-resolution mode is not supported on your system, try using a lower-resolution mode. For example, 1024 x 768 mode will not work on some systems, but 800 x 600 mode is supported on most.

Necessary prerequisites

The instructions in this manual assume that you understand elementary concepts of MS-DOS and the IBM Personal Computer. Before you attempt to install any driver or utility, you should:

- Know how to copy files from a CD-ROM to a directory on the hard disk
- Understand the MS-DOS directory structure

If you are uncertain about any of these concepts, please refer to the DOS or OS/2 user reference guides for more information *before* you proceed with the installation.

Before you begin

Make sure you know the version of the application for which you are installing drivers. The *Supporting CD-ROM* contain drivers for several versions of certain applications. For your driver to operate properly, you must install the driver for your version of the application program.

Windows[®] 95

These drivers are designed to work with Microsoft[®] Windows[®]. You just install these drivers through the Windows[®] operating system.

Driver installation

1. Install Windows[®] 95 as you normally would for a VGA display. Click the **Start** button, go to **Settings** and click on **Control Panel**. Choose the **Display** icon and double click on the icon. In the *Display Properties* window, show as figure 1:



figure 1

Click the **setting** button, then click the **Advanced Properties** icon into the Advanced Display properties windows, show as figure2:

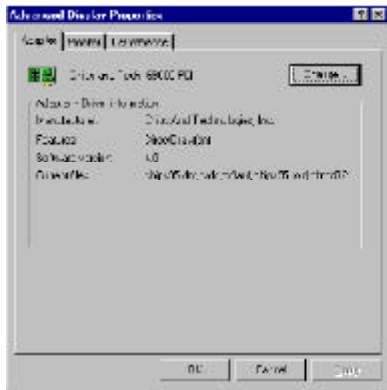

figure 2

click on **Change Display Type**. In the *Change Display Type* window, click on the **Change** button under Adapter Type into the select Device window show as figure(3):This will bring up the *Select Device* window.

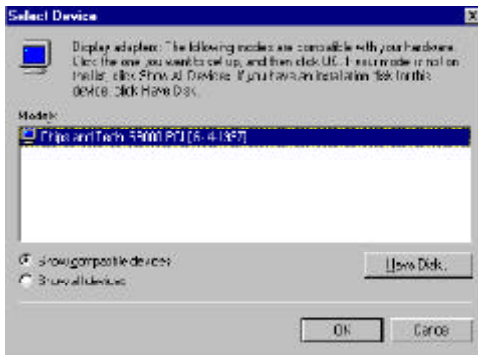

figure 3

2. Place the *Supporting CD-ROM* in your CD-ROM drive.

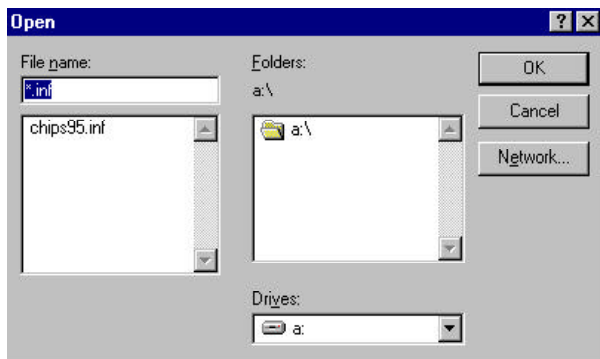

figure 4

In the *Select Device* window, click on **Have Disk**, Select **Browse**, and find the Win95 driver "*chips95.inf*" in the Supporting CD-ROM with the following path, and then click OK.

cd-rom: \CD-ROM*model name*\driver\vga driver\win95\

"*cd-rom*": the drive letter of your CD-ROM drive

"*model name*": the model number of your product

The name of the *Chips And Techn "69000 PCI"* driver will appear highlighted in the *Models* list box how as figure. Click OK to start the driver installation show as figure 6:

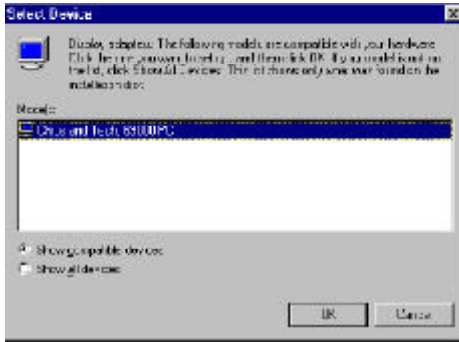

figure 6

3. Once the installation is complete, the *Advanced display Properties* window will reappear. Show as figure (7):

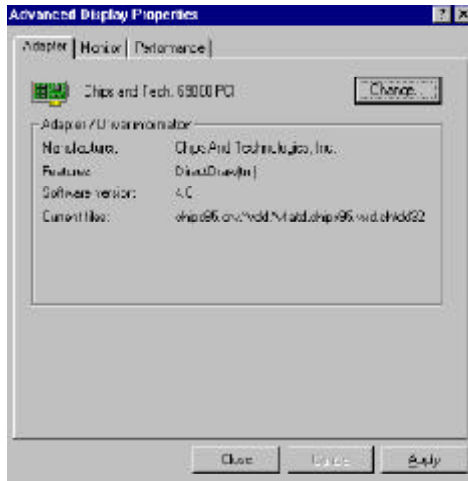

figure 7

Click on **close** to close the window. Then the *Display Properties* window will reappear. Show as figure (8):

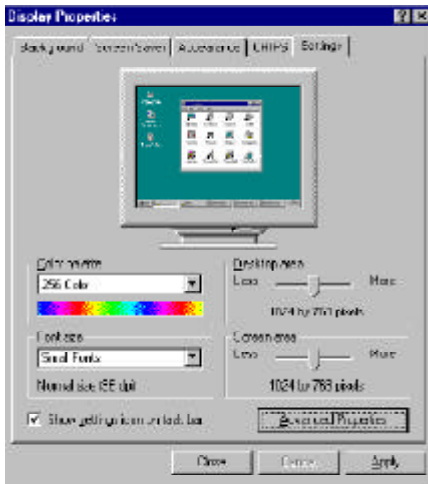

figure 8

Click on **Apply**. Restart the system for the new settings to take effect, show as figure (9):

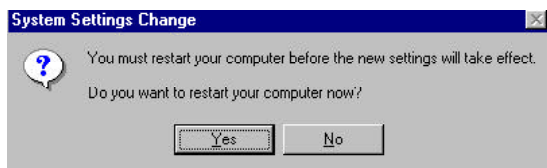

figure 9

Windows[®] NT 3.51

These drivers are designed to work with Microsoft[®] Windows[®].

Driver installation

1. Install Windows[®] NT 3.51 as you normally would for a **VGA** display. Click the **Star** button, go to **Settings** and click on **Control Panel** icon. Then choose the **Display** and double click on the icon. In the **Display Properties** window, click the **Setting** button, then click the **Display Type** button into the **Display Type** windows, then click on **Change** button from the **Adapter Type** icon. And click on **Have Disk** button in the change display window.
2. Place the *Supporting CD-ROM* into your CD-ROM drive.

and type:

cd-rom: \CD ROM*model name*\drive\vga drive\
win98 nt\windows.nt\nt35\Oemsetup.inf

"**cd-rom:**": the drive letter of your CD-ROM drive

"**model name**": the model number of your product

Select the adapter "Chips and Tech 69000PCI" and click OK.

Click on Install to install the selected driver. Once the installation is complete, shut down and restart the system.

Windows[®] NT 4.0

Driver installation

1. Install Windows[®] NT 4.0 as you normally would for a **VGA** display. Click the **Star** button, go to **Settings** and click on **Control Panel** icon. Then choose the **Display** and double click on the icon. In the **Display Properties** window, click the **Setting** button, then click the **Display Type** button into the **Display Type** windows, then click on **Change** button from the **Adapter Type** icon. And click on **Have Disk** button in the change display window.
2. Place the *Supporting CD-ROM* into your CD-ROM drive. In the **Select Device** window, click on **Have Disk**, select "**Browse**" and find the NT 4.0 driver from:

cd-rom : \CD ROM*model name*\dirver\vga driver\
win98 nt\windows.nt\nt40\Oemsetup.inf

"*cd-rom*:" the drive letter of your CD-ROM drive

"*model name*": the model number of your product

and then click OK. The name of the *Chips and Technologies, Inc. Video Controller* driver will appear highlighted in the Modules list box. Select Chips and Tech. 69000 and Click **OK**. Click **OK** to start the driver installation.

3. Once the installation is complete, the **Change Display Type** window will reappear. Click on close to close the window. Then the **Display Properties** window will reappear. Click on **Apply**. Restart the system for the new settings to take effect.

Ethernet Software Configuration

This chapter describes how to configure the Ethernet Card to match your application requirements.

Ethernet software configuration

The onboard Ethernet interface supports all major network operating systems. I/O addresses and interrupts are easily configured via the Award BIOS Setup. To configure the medium type, to view the current configuration, or to run diagnostics, please refer to the following instruction:

1. Power the mainboard on. Ensure that the RSET8139.EXE file is located in the working drive.
2. At the prompt, type RSET8139.EXE and press <ENTER>. The Ethernet configuration program will then be displayed.
3. This simple screen shows all the available options for the Ethernet interface. Just highlight the option you wish to change by using the Up and DOWN keys. To change a selected item, press <ENTER>, and a screen will appear with the available options. Highlight your option and press <ENTER>. Each highlighted option has a helpful message guide displayed at the bottom of the screen for additional information.
4. After you have made your selections and the configuration is what you want, press <ESC>. A prompt will appear asking if you want to save the configuration. Press "Y" if you want to save.

The Ethernet Setup Menu also offers three very useful diagnostic functions. These are:

1. Run EEPROM test
2. Run Diagnostics on Board
3. Run Diagnostics on Network

Each option has its own display screen which shows the format and result of any diagnostic tests undertaken.

APPENDIX

A

Watchdog Timer

Watchdog Timer

SBC-656 contains a watchdog timer reset pin. (GP13)

All reference material can be found on the following pages.

What the decoded address of the W83977 ?

The decoded address of the W83977 is 3F0h.

How to enter or exit the configuration mode ?

In order to enter the configuration mode, you must write the value **87h** to the configuration port **3F1h** 2 times each.

In order to exit the configuration mode, you must write the value **AAh** to the configuration port **3F1h**.

How to enable or disable the Watchdog Timer ?

In order to enable the Watchdog Timer, you must write the value **01h** to the register 30 (**CR30**) of the Logic Device 7.

In order to disable the Watchdog Timer, you must write the value **00h** to the register 30 (**CR30**) of the Logic Device 7

How to set time-out value ?

In order to set time-out value, you must write a value which is between 01h and FFh to the register F2 (**CRF2**) of the Logic Device 8.
For example,

01h : Time-out occurs after 32 seconds

02h : Time-out occurs after 1 minute and 32 seconds

FFh : Time-out occurs after 254 minutes and 32 seconds

And the following pages show watchdog timer setup Utility program for your reference.

```

=====**
** Title : WatchDog Timer Setup Utility (for W83977 GP13) **
** Company : AAEON Technology Inc. **
** Compiler : Borland C ++ Version 3.0 **
**=====*/

```

```

#include <dos.h>
#include <io.h>
#include <bios.h>
#include <stdio.h>
#include <stdlib.h>
#include <conio.h>

```

```

/* Set I/O Address : 370/371 or 3F0/3F1 */

```

```

#define IO_INDEX_PORT 0x3f0

```

```

#define IO_DATA_PORT 0x3f1

```

```

/* Set Watchdog reset pin : 12/13/16 */

```

```

#define watch_dog_output_GP 13

```

```

#define UNLOCK_DATA 0x87

```

```

#define LOCK_DATA 0xAA

```

```

#define DEVICE_REGISTER 0x07

```

```

void EnterConfigMode()

```

```

{
    outportb(IO_INDEX_PORT, UNLOCK_DATA);
    outportb(IO_INDEX_PORT, UNLOCK_DATA);
}

```

```

void ExitConfigMode()

```

```

{
    outportb(IO_INDEX_PORT, LOCK_DATA);
}

```

```

void SelectDevice(unsigned char device)
{
    outportb(IO_INDEX_PORT, DEVICE_REGISTER);
    outportb(IO_DATA_PORT, device);
}

unsigned char ReadAData(short int reg)
{
    outportb(IO_INDEX_PORT, reg);
    return (inportb(IO_DATA_PORT));
}

void WriteAData(unsigned char reg, unsigned char data)
{
    outportb(IO_INDEX_PORT, reg);
    outportb(IO_DATA_PORT, data);
}

void SetWatchDogTime(unsigned char time_val)
{
    EnterConfigMode();
    SelectDevice(8);
    //Set Register F2
    //Set Watch-Dog Timer 1~ 256
    WriteAData(0xF2, time_val);
    // set counter counts in second (or minute)
    // Register F4 Bit 6 = 0/1 (minutes/seconds)
    //For w83977EF only
    WriteAData(0xF4, 0x40);
    ExitConfigMode();
}

```

```

void init_w83977f_aw_watchdog()
{
    short int value;

    //Enter W83977 Configure Mode
    EnterConfigMode();

    //Select Device 7
    SelectDevice(7);
    //Set Device Active
    WriteAData(0x30, 0x01);

    //caution:skip this step will be a mistake!!
    if (watch_dog_output_GP==12)
    {
        //Set Register E2 to define GP12
        WriteAData(0xE2, 0x0A);
    }
    else if(watch_dog_output_GP==13)
    {
        //Set Register E3 to define GP13
        WriteAData(0xE3, 0x0A);
    }
    else if(watch_dog_output_GP==16)
    {
        //Set Register E6 to define GP16
        WriteAData(0xE6, 0x0A);
    }

    //Select Device 8
    SelectDevice(8);
    //Set Register F3
    //keyboard and mouse interrupt reset Enable
    //When Watch-Dog Time-out occurs,Enable POWER LED
    output
    WriteAData(0xF3, 0x0E);
}

```

```

//caution:skip this step will be a mistake!!
if (watch_dog_output_GP==12)
{
//Set Register 2A (PIN 57) Bit 7 = 0/1 (KBLOCK/GP12)
//set to GP12 for WD Rst
WriteAData(0x2A,ReadAData(0x2A)|0x80);
}
else if(watch_dog_output_GP==13)
{
//Set Register 2B (PIN 58) Bit 0 = 0/1 (KBLOCK/GP13)
//set to GP13 for WD Rst
WriteAData(0x2B,ReadAData(0x2B)|0x01);
}
else if(watch_dog_output_GP==16)
{
//Set Register 2C (PIN 119) Bit 5-4 = 01 (GP16)
//set to GP16 for WD Rst
WriteAData(0x2C,ReadAData(0x2C)|0x10);
}

//Exit W83977 Configure mode
ExitConfigMode();
}

void main(int argc, char* argv[])
{
    int time_value=0;
    char *ptr;
    printf("WinBond 83977 WatchDog Timer Setup Utility
Version 1.0 \n");
    printf("Copyright (c) 2000 AAeon Technology Inc.\n");
    printf("This version only for W83977 that using GP%d to
Reset System.\n",watch_dog_output_GP);
}

```

```

if (argc == 1)
{
    printf("\n Syntax: WATCHDOG [time] \n");
    printf(" time range : 1 ~ 256 \n\n");
    return ;
}
if (argc > 1)
{
    ptr = argv[1];
    time_value = atoi(ptr);
}
if (time_value > 0 && time_value < 256)
{
    SetWatchDogTime((unsigned char) time_value);
    init_w83977tf_aw_watchdog();
    printf("Watch Dog Timer set up : %d \n",time_value);
}
}

```

APPENDIX

B

Installing PC/104 Modules

This appendix provides instructions for installing PC/104 modules.

Installing PC/104 modules

The SBC-656's PC/104 connectors give you the flexibility to attach PC/104 expansion modules. These modules perform the functions of traditional plug-in expansion cards, but save space and valuable slots. Modules include:

- **PCM-3115B** PCMCIA Module (two-slot)
- **PCM-3610** Isolated RS-232 and RS-422/485 Module
- **PCM-3660** Ethernet Module
- **PCM-3718H** 30 KHz A/D Module
- **PCM-3724** 48-channel DIO Module
- **PCM-3840** Solid State Disk Module
- **PCM-5600** PC/104 Fax/Modem Module

Installing these modules on the SBC-656 is a quick and simple operation. The following steps show how to mount the PC/104 modules:

- Step1 Remove the SBC-656 from your system, paying particular attention to the safety instructions already mentioned above.
- Step2 Make any jumper or link changes required to the SBC now. Once the PC/104 module is mounted, you may have difficulty in accessing these.
- Step3 Mount the PC/104 module onto the SBC. Do this by pressing the module firmly but carefully onto the mounting connectors.
- Step4 Secure the PC/104 module onto the SBC using the four mounting spacers and screws.

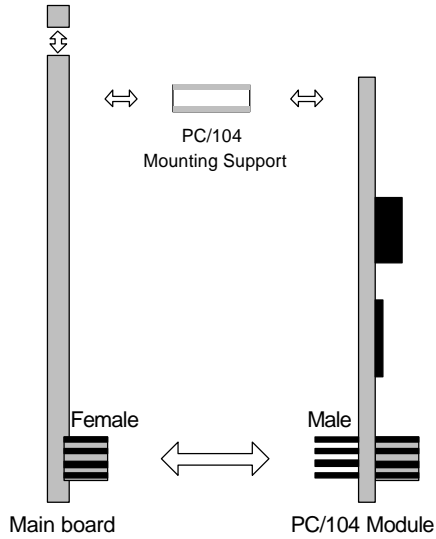

PC/104 Module Mounting Diagram

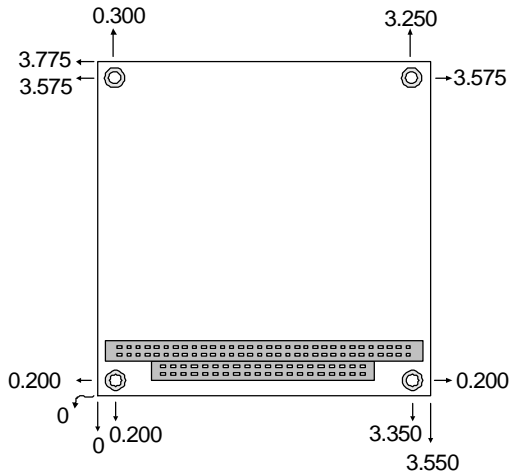

PC/104 module dimensions (inches +/- 5%)

