

RICO-3399

Rockchip RK3399 Platform

User's Manual 2nd Ed

Copyright Notice

This document is copyrighted, 2020. All rights are reserved. The original manufacturer reserves the right to make improvements to the products described in this manual at any time without notice.

No part of this manual may be reproduced, copied, translated, or transmitted in any form or by any means without the prior written permission of the original manufacturer. Information provided in this manual is intended to be accurate and reliable. However, the original manufacturer assumes no responsibility for its use, or for any infringements upon the rights of third parties that may result from its use.

The material in this document is for product information only and is subject to change without notice. While reasonable efforts have been made in the preparation of this document to assure its accuracy, AAEON assumes no liabilities resulting from errors or omissions in this document, or from the use of the information contained herein.

AAEON reserves the right to make changes in the product design without notice to its users.

Acknowledgement

All other products' name or trademarks are properties of their respective owners.

- Rockchip® is a registered trademark of Fuzhou Rockchip Electronics Co., Ltd.
- Arm® and Cortex® are registered trademarks of Arm Limited (or its subsidiaries)
- Android™ is a registered trademark of Google LLC
- ITE is a trademark of Integrated Technology Express, Inc.

All other product names or trademarks are properties of their respective owners.

Packing List

Before setting up your product, please make sure the following items have been shipped:

Item	Quantity
● RICO-3399	1
● RTC Battery	1
● MB Power Cable	1

If any of these items are missing or damaged, please contact your distributor or sales representative immediately.

About this Document

This User's Manual contains all the essential information, such as detailed descriptions and explanations on the product's hardware and software features (if any), its specifications, dimensions, jumper/connector settings/definitions, and driver installation instructions (if any), to facilitate users in setting up their product.

Users may refer to the product page at AAEON.com for the latest version of this document.

Safety Precautions

Please read the following safety instructions carefully. It is advised that you keep this manual for future references

1. All cautions and warnings on the device should be noted.
2. Make sure the power source matches the power rating of the device.
3. Position the power cord so that people cannot step on it. Do not place anything over the power cord.
4. Always completely disconnect the power before working on the system's hardware.
5. No connections should be made when the system is powered as a sudden rush of power may damage sensitive electronic components.
6. If the device is not to be used for a long time, disconnect it from the power supply to avoid damage by transient over-voltage.
7. Always disconnect this device from any AC supply before cleaning.
8. While cleaning, use a damp cloth instead of liquid or spray detergents.
9. Make sure the device is installed near a power outlet and is easily accessible.
10. Keep this device away from humidity.
11. Place the device on a solid surface during installation to prevent falls
12. Do not cover the openings on the device to ensure optimal heat dissipation.
13. Watch out for high temperatures when the system is running.
14. Do not touch the heat sink or heat spreader when the system is running
15. Never pour any liquid into the openings. This could cause fire or electric shock.
16. As most electronic components are sensitive to static electrical charge, be sure to ground yourself to prevent static charge when installing the internal components. Use a grounding wrist strap and contain all electronic components in any static-shielded containers.

17. If any of the following situations arises, please contact our service personnel:
 - i. Damaged power cord or plug
 - ii. Liquid intrusion to the device
 - iii. Exposure to moisture
 - iv. Device is not working as expected or in a manner as described in this manual
 - v. The device is dropped or damaged
 - vi. Any obvious signs of damage displayed on the device
18. **DO NOT LEAVE THIS DEVICE IN AN UNCONTROLLED ENVIRONMENT WHERE THE STORAGE TEMPERATURE IS BELOW -20° C (-4°F) OR ABOVE 60°C (140°F) TO PREVENT DAMAGE.**

Warning!



This device complies with Part 15 FCC Rules. Operation is subject to the following two conditions: (1) this device may not cause harmful interference, and (2) this device must accept any interference received including interference that may cause undesired operation.

Caution:

There is a danger of explosion if the battery is incorrectly replaced. Replace only with the same or equivalent type recommended by the manufacturer. Dispose of used batteries according to the manufacturer's instructions and your local government's recycling or disposal directives.

Attention:

Il y a un risque d'explosion si la batterie est remplacée de façon incorrecte. Ne la remplacer qu'avec le même modèle ou équivalent recommandé par le constructeur. Recycler les batteries usées en accord avec les instructions du fabricant et les directives gouvernementales de recyclage.

China RoHS Requirements (CN)

产品中有毒有害物质或元素名称及含量

AAEON Main Board/ Daughter Board/ Backplane

部件名称	有毒有害物质或元素					
	铅 (Pb)	汞 (Hg)	镉 (Cd)	六价铬 (Cr(VI))	多溴联苯 (PBB)	多溴二苯醚 (PBDE)
印刷电路板 及其电子组件	○	○	○	○	○	○
外部信号 连接器及线材	○	○	○	○	○	○
<p>O: 表示该有毒有害物质在该部件所有均质材料中的含量均在 SJ/T 11363-2006 标准规定的限量要求以下。</p> <p>X: 表示该有毒有害物质至少在该部件的某一均质材料中的含量超出 SJ/T 11363-2006 标准规定的限量要求。</p> <p>备注: 此产品所标示之环保使用期限, 系指在一般正常使用状况下。</p>						

China RoHS Requirement (EN)

Poisonous or Hazardous Substances or Elements in Products

AAEON Main Board/ Daughter Board/ Backplane

Component	Poisonous or Hazardous Substances or Elements					
	Lead (Pb)	Mercury (Hg)	Cadmium (Cd)	Hexavalent Chromium (Cr(VI))	Polybrominated Biphenyls (PBB)	Polybrominated Diphenyl Ethers (PBDE)
PCB & Other Components	○	○	○	○	○	○
Wires & Connectors for External Connections	○	○	○	○	○	○
<p>O: The quantity of poisonous or hazardous substances or elements found in each of the component's parts is below the SJ/T 11363-2006-stipulated requirement.</p> <p>X: The quantity of poisonous or hazardous substances or elements found in at least one of the component's parts is beyond the SJ/T 11363-2006-stipulated requirement.</p> <p>Note: The Environment Friendly Use Period as labeled on this product is applicable under normal usage only</p>						

Table of Contents

Chapter 1 - Product Specifications	1
1.1 Specifications	2
Chapter 2 – Hardware Information	4
2.1 Dimensions	5
2.2 Jumpers and Connectors.....	6
2.3 List of Jumpers	7
2.3.1 Power Button (JP2)	7
2.3.2 RS-232/422/485 (D-Sub) Voltage Output Selection (JP3)	7
2.3.3 eDP Port Voltage Selection (JP4).....	8
2.3.4 eDP Port Backlight Voltage Selection (JP5)	8
2.3.5 Integrated (UART/I2C/GPIO/Others) (JP6)	8
2.3.6 COM Port Setting (JP7/JP8).....	8
2.4 List of Connectors.....	9
2.4.1 RTC Battery Connector (CN1).....	10
2.4.2 I-PEX Connector for Wi-Fi (CN2)	10
2.4.3 mPCIe Slot for WWAN Card (CN3H3).....	10
2.4.4 Nano-SIM Slot (CN4)	11
2.4.5 RS-232/422/485 Port (D-Sub) (CN5).....	11
2.4.6 USB 3.2 Gen 1 (Bottom)/ USB 2.0 (Top) Dual Port (CN6)	12
2.4.7 USB 3.2 Gen 1 Type C OTG (CN7)	12
2.4.8 Debug Port (CN8).....	13
2.4.9 Gigabit Ethernet (GbE) Port (CN9)	13
2.4.11 eDP Connector (CN11).....	14
2.4.13 HDMI 2.0 Port Type A (CN13).....	14
2.4.14 Micro-SD Card Slot (CN14)	15
2.4.15 Speaker Connector (CN15)	15

2.4.16	DC Power Input (CN16).....	15
2.4.19	Integrated USB, I2C x 2, 5V (CN19).....	16
2.4.21	RS-232 Port (CN21)	16
2.4.22	GPIO Port (CN22)	16
2.5	Function Block.....	17
Appendix A – Mating Connectors		18
A.1	List of Mating Connectors and Cables.....	19

Chapter 1

Product Specifications

1.1 Specifications

System

Form Factor	Pico-ITX
CPU	Rockchip RK3399 Cortex™-A72 Dual-core 1.8GHz and Cortex™-A53 Quad-core 1.4GHz
GPU	Mali-T864
Graphics	Video Decode: MPEG-1, MPEG-2, MPEG-4, H.263, H.264, H.265, VC-1, VP8, VP9, MVC Video Encode: H.264 UP to HP @ level4.1, MVC and VP8
Memory Capacity	Onboard LPDDR3 2GB/4GB (Optional)
Storage/SSD	16GB eMMC and Micro-SD card
Operating System	Android 8.1
Kernel	Kernel 4.4
Watchdog Timer	Integrated
Power Requirement	+12V DC input
Power Consumption (Typical)	0.6A@12V, full load, Hexa-core CPU
Dimension	3.94" x 2.84" (100 mm x 72 mm)
Gross Weight	0.44 lb (0.2 Kg)
Operating Temperature	32°F ~ 140°F (0°C ~ 60°C)
Storage Temperature	-40°F ~ 176°F (-40°C ~ 80°C)
Operating Humidity	0% ~ 90% relative humidity, non-condensing
MTBF (Hours)	80,000
Certification	CE/FCC

Display

HDMI	HDMI (2.0) up to 4K x 2K @60Hz
eDP	Up to 4K x 2K @60Hz
LVDS	—
MIPI	—

RF Function

Wi-Fi	802.11 a/b/g/n/ac
BT	Bluetooth V4.2 + EDR

I/O

Ethernet	GbE x 1
USB Port	USB 3.2 Gen 1 Type C OTG x 1 USB 3.2 Gen 1 (Bottom)/USB 2.0 (Top) dual port x 1 USB 2.0 Pin Header x 1 (Integrated)
Serial Port	RS-232/422/485 x 1 RS-232 Pin header x 1 Debug port pin header x 1
Audio	2.5W (by 4Ω) Speaker/ Microphone/ Earphone
GPIO	8-bit (4-in, 4-out)
Expansion Slot	Full-size mini-PCIe slot x 1 (For 3G/4G card)
SIM Slot	Nano-SIM
SD Socket	Support Micro-SD card
Camera	—

Chapter 2

Hardware Information

2.1 Dimensions

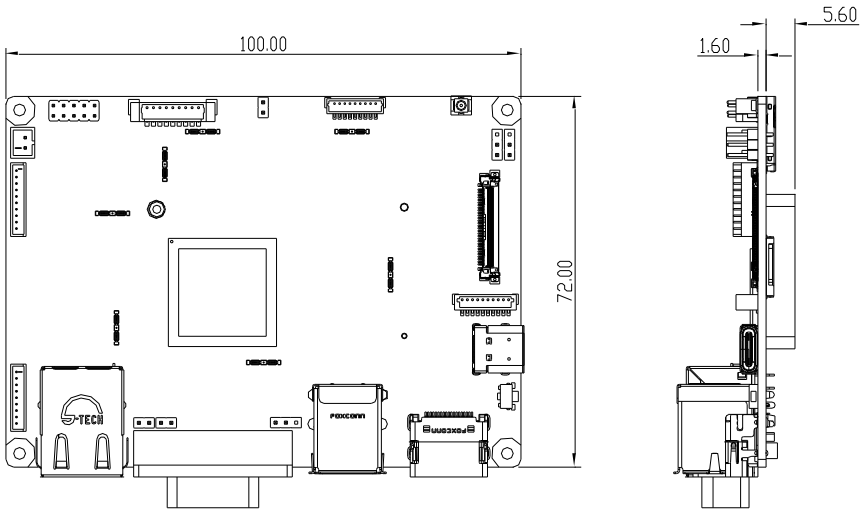

2.2 Jumpers and Connectors

Top

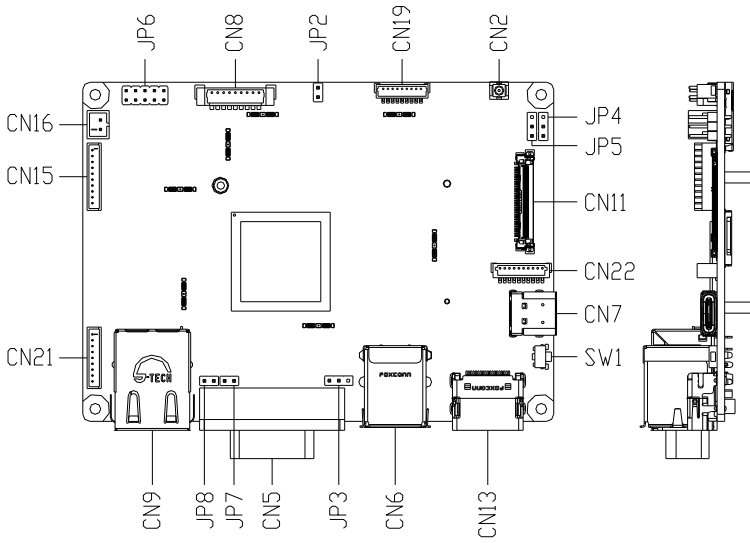

Bottom

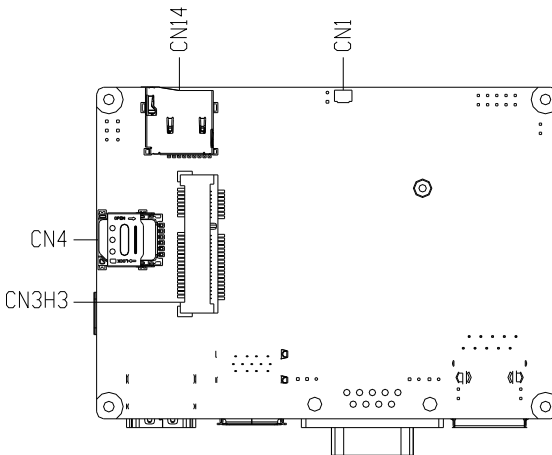

2.3 List of Jumpers

Please refer to the table below for all of the board's jumpers that you can configure for your application

Label	Function
JP2	Power Button
JP3	RS-232/422/485 (D-Sub) Voltage Output Selection
JP4	eDP Port Voltage Selection
JP5	eDP Port Backlight Voltage Selection
JP6	Integrated (UART/I2C/GPIO/Others)
JP7/ JP8	COM port setting
SW1	Image Flash Switch

2.3.1 Power Button (JP2)

Pin	Definition
1	PWR_KEY#
2	GND

2.3.2 RS-232/422/485 (D-Sub) Voltage Output Selection (JP3)

Pin	Definition
1	12V
2	R1#/12V/5V
3	5V

2.3.3 eDP Port Voltage Selection (JP4)

Pin	Definition
1-2	+5V
2-3	+3.3V

2.3.4 eDP Port Backlight Voltage Selection (JP5)

Pin	Definition
1-2	+5V
2-3	+12V

2.3.5 Integrated (UART/I2C/GPIO/Others) (JP6)

Pin	Definition	Pin	Definition
1	+3.3V	6	I2C1_CLK
2	GPIO0	7	GND
3	UART4_TX	8	I2C1_DATA
4	GPIO1	9	GPIO2
5	UART4_RX	10	GPIO3

2.3.6 COM Port Setting (JP7/JP8)

Mode	JP7	JP8
RS422	Open	Open
RS232	Open	Short
RS485	Short	Short

2.4 List of Connectors

Please refer to the table below for all of the board's connectors that you can configure for your application

Label	Function
CN1	RTC Battery Connector
CN2	I-PEX Connector for Wi-Fi
CN3H3	mPCIe Slot for WWAN Card
CN4	Nano-SIM Slot
CN5	RS-232/422/485 Port (D-Sub)
CN6	USB 3.2 Gen 1 (Bottom)/ USB 2.0 (Top) Dual Port
CN7	USB 3.2 Gen 1 Type C OTG
CN8	Debug Port
CN9	Gigabit Ethernet (GbE) Port
CN11	eDP Connector
CN13	HDMI 2.0 Port Type A
CN14	Micro-SD Card Slot
CN15	Speaker Connector
CN16	DC Power Input
CN19	Integrated USB, I2C x 2, 5V
CN21	RS-232 Port
CN22	GPIO Port

2.4.1 RTC Battery Connector (CN1)

Pin	Definition
1	+3.3V
2	GND

2.4.2 I-PEX Connector for Wi-Fi (CN2)

Standard specifications.

2.4.3 mPCIe Slot for WWAN Card (CN3H3)

Pin	Definition	Pin	Definition	Pin	Definition	Pin	Definition
1	WAKE_UP	14	USIM_RESET	27	GND	40	GND
2	+3.3V	15	GND	28	N.C	41	+3.3V
3	N.C	16	N.C	29	GND	42	N.C
4	GND	17	WAKE_UP_OUT	30	N.C	43	GND
5	N.C	18	GND	31	N.C	44	N.C
6	N.C	19	N.C	32	N.C	45	N.C
7	N.C	20	DISABLE	33	N.C	46	N.C
8	USIM_PWR	21	GND	34	GND	47	N.C
9	GND	22	RESET	35	N.C	48	N.C
10	USIM_DATA	23	N.C	36	USB1_D-	49	N.C
11	N.C	24	+3.3V	37	GND	50	GND
12	USIM_CLK	25	N.C	38	USB1_D+	51	N.C
13	N.C	26	GND	39	+3.3V	52	+3.3V

2.4.4 Nano-SIM Slot (CN4)

Pin	Definition	Pin	Definition
C1	USIM_PWR	C5	GND
C2	USIM_RESET	C6	N.C
C3	USIM_CLK	C7	USIM_DATA

2.4.5 RS-232/422/485 Port (D-Sub) (CN5)

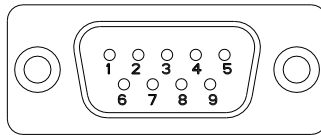

RS-232

Pin	Definition	Pin	Definition
1	DCD	6	DSR
2	RX	7	RTS
3	TX	8	CTS
4	DTR	9	Vout (refer to JP3)
5	GND		

RS-485

Pin	Definition	Pin	Definition
1	RS485_D-(B)	6	N.C
2	RS485_D+(A)	7	N.C
3	N.C	8	N.C
4	N.C	9	N.C
5	N.C		

RS-422

Pin	Definition	Pin	Definition
1	RS422_TX-(B)	6	N.C
2	RS422_TX+(A)	7	N.C
3	RS422_RX+(A)	8	N.C
4	RS422_RX-(B)	9	N.C
5	N.C		

2.4.6 USB 3.2 Gen 1 (Bottom)/ USB 2.0 (Top) Dual Port (CN6)

Pin	Definition	Pin	Definition
1	+5V	5	+5V
2	USB2_D-	6	USB3_D-
3	USB2_D+	7	USB3_D+
4	GND	8	GND

2.4.7 USB 3.2 Gen 1 Type C OTG (CN7)

Pin	Definition
1	+5V
2	OTG_USB_D-
3	OTG_USB_D+
4	OTG_ID
5	GND

2.4.8 Debug Port (CN8)

Pin	Definition	Pin	Definition
1	N.C	6	N.C
2	N.C	7	N.C
3	RX	8	N.C
4	N.C	9	GND
5	TX		

2.4.9 Gigabit Ethernet (GbE) Port (CN9)

Pin	Definition	Pin	Definition
1	TX+_D1	5	BI-_D3
2	TX-_D1	6	RX-_D2
3	RX+_D2	7	BI+_D4
4	BI+_D3	8	BI-_D4

2.4.11 eDP Connector (CN11)

Pin	Definition	Pin	Definition	Pin	Definition
1	GND	11	GND	21	eDP_HPD
2	eDP_TX0-	12	LCD_PWR	22	BKL_ENABLE
3	eDP_TX0+	13	LCD_PWR	23	BKL_CONTROL
4	GND	14	eDP_TX3-	24	GND
5	eDP_TX1-	15	eDP_TX3+	25	GND
6	eDP_TX1+	16	GND	26	BKL_PWR
7	GND	17	eDP_AUX-	27	BKL_PWR
8	eDP_TX2-	18	eDP_AUX+	28	BKL_PWR
9	eDP_TX2+	19	GND	29	BKL_PWR

Note: For Pins 26, 27, 28 and 29 BKL_PWR, refer to JP2 for setting information

2.4.13 HDMI 2.0 Port Type A (CN13)

Pin	Definition	Pin	Definition
1	HDMI_TX2P	11	GND
2	GND	12	HDMI_CLKN
3	HDMI_TX2N	13	HDMI_CEC
4	HDMI_TX1P	14	N.C
5	GND	15	DDC_SCL
6	HDMI_TX1N	16	DDC_SDA
7	HDMI_TX0P	17	GND
8	GND	18	+5V
9	HDMI_TX0N	19	HDMI_HPD
10	HDMI_CLKP		

2.4.14 Micro-SD Card Slot (CN14)

Pin	Definition	Pin	Definition
1	DAT2	6	GND
2	DAT3	7	DAT0
3	CMD	8	DAT1
4	+3.3V	9	CD
5	CLK	10	GND

2.4.15 Speaker Connector (CN15)

Pin	Definition	Pin	Definition
1	GND	6	RIGHT_OUT
2	MIC	7	Spk_L_P
3	HP_DET	8	Spk_L_N
4	GND	9	Spk_R_P
5	LEFT_OUT	10	Spk_R_N

2.4.16 DC Power Input (CN16)

Pin	Definition
1	GND
2	+12V

2.4.19 Integrated USB, I2C x 2, 5V (CN19)

Pin	Definition	Pin	Definition
1	I2C4_CLK	6	USB1_D-
2	I2C4_DATA	7	I2C3_CLK
3	GND	8	I2C3_DATA
4	+5V	9	NFC_DFU
5	USB1_D+		

2.4.21 RS-232 Port (CN21)

Pin	Definition	Pin	Definition
1	DCD	6	DSR
2	RX	7	RTS
3	TX	8	CTS
4	DTR	9	Vout (refer to JP3)
5	GND		

2.4.22 GPIO Port (CN22)

Pin	Definition	Pin	Definition
1	GPO0	6	GPI2
2	GPI0	7	GPO3
3	GPO1	8	GPI3
4	GPI1	9	+3.3V
5	GPO2	10	GND

2.5 Function Block

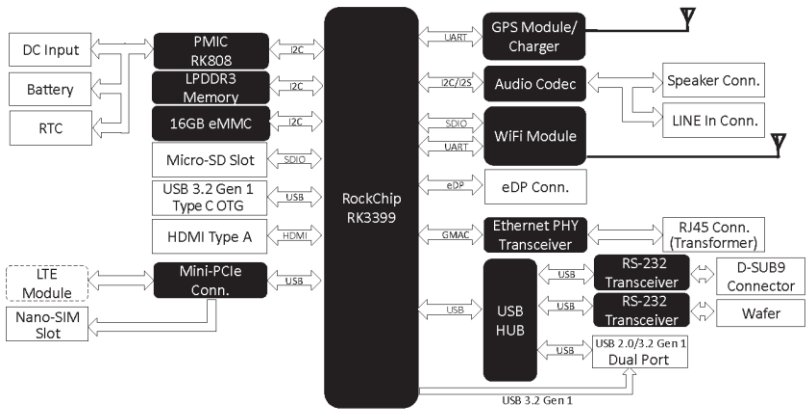

Appendix A

Mating Connectors

A.1 List of Mating Connectors and Cables

Connector Label	Function	Mating Connector		Available Cable	Cable P/N
		Vendor	Model No		
CN1	RTC Battery Connector	A ECS	50208-00201-001	N/A	N/A
CN2	I-PEX Connector for Wi-Fi	I-PEX	20279-001E	Coaxial Cable	1700010252
CN3H3	mPCIe Slot for WWAN Card	FOXCONN	AS0B22x-S56Q-7H	N/A	N/A
CN4	Nano-SIM Slot	SUNFUN	SMHN-SO1(01T)	N/A	N/A
CN5	RS-232/422/485 Port (D-Sub)	ASTRON	DB6A-09-AMAN1T-R	N/A	N/A
CN6	USB 3.2 Gen 1 (Bottom)/ USB 2.0 (Top) Dual Port	FOXCONN	UEA1112C-UHS6-4F	N/A	N/A
CN7	USB 3.2 Gen 1 Type C OTG	TRONTEK	A32-05U7-112	N/A	N/A
CN8	Debug Port	SUNDA	AS07600095101	D-sub9 console cable	1701090150
CN9	GbE Port	SPEEDTECH	RJL4A-4WH1-FP0-0R	N/A	N/A
CN11	eDP Connector	I-PEX	20455-030E-12	N/A	N/A
CN13	HDMI Port	FOXCONN	QJ51191-LFB4-7F	N/A	N/A
CN14	Micro-SD Card Slot	ATTEND	112J-TDAR-R01	N/A	N/A
CN15	Speaker Connector	PINREX	712-H71-105W01	N/A	N/A
CN16	DC Power Input	CATCH	1192-700-02S	N/A	N/A
CN19	Integrated USB, I2C x 2, 5V	PINREX	710-H73-095WE1	N/A	N/A

Connector Label	Function	Mating Connector		Available Cable	Cable P/N
		Vendor	Model No		
CN21	RS-232 Port	PINREX	712-71-09TW01	D-sub9 console cable	1701090150
CN22	GPIO Port	CATCH	1204-700-10SMR	N/A	N/A