

# RICO-3288

---

Rockchip RK3288 Platform

User's Manual 2<sup>nd</sup> Ed

## Copyright Notice

---

This document is copyrighted, 2018. All rights are reserved. The original manufacturer reserves the right to make improvements to the products described in this manual at any time without notice.

No part of this manual may be reproduced, copied, translated, or transmitted in any form or by any means without the prior written permission of the original manufacturer. Information provided in this manual is intended to be accurate and reliable. However, the original manufacturer assumes no responsibility for its use, or for any infringements upon the rights of third parties that may result from its use.

The material in this document is for product information only and is subject to change without notice. While reasonable efforts have been made in the preparation of this document to assure its accuracy, AAEON assumes no liabilities resulting from errors or omissions in this document, or from the use of the information contained herein.

AAEON reserves the right to make changes in the product design without notice to its users.

## Acknowledgement

---

All other products' name or trademarks are properties of their respective owners.

- Microsoft Windows® is a registered trademark of Microsoft Corp.
- ITE is a trademark of Integrated Technology Express, Inc.
- IBM, PC/AT, PS/2, and VGA are trademarks of International Business Machines Corporation.

All other product names or trademarks are properties of their respective owners.

## Packing List

---

Before setting up your product, please make sure the following items have been shipped:

Item	Quantity
● RICO-3288	1
● RTC Battery	1
● MB Power Cable	1

If any of these items are missing or damaged, please contact your distributor or sales representative immediately.

## About this Document

---

This User's Manual contains all the essential information, such as detailed descriptions and explanations on the product's hardware and software features (if any), its specifications, dimensions, jumper/connector settings/definitions, and driver installation instructions (if any), to facilitate users in setting up their product.

Users may refer to the [AAEON.com](http://AAEON.com) for the latest version of this document.

## Safety Precautions

---

Please read the following safety instructions carefully. It is advised that you keep this manual for future references

1. All cautions and warnings on the device should be noted.
2. Make sure the power source matches the power rating of the device.
3. Position the power cord so that people cannot step on it. Do not place anything over the power cord.
4. Always completely disconnect the power before working on the system's hardware.
5. No connections should be made when the system is powered as a sudden rush of power may damage sensitive electronic components.
6. If the device is not to be used for a long time, disconnect it from the power supply to avoid damage by transient over-voltage.
7. Always disconnect this device from any AC supply before cleaning.
8. While cleaning, use a damp cloth instead of liquid or spray detergents.
9. Make sure the device is installed near a power outlet and is easily accessible.
10. Keep this device away from humidity.
11. Place the device on a solid surface during installation to prevent falls
12. Do not cover the openings on the device to ensure optimal heat dissipation.
13. Watch out for high temperatures when the system is running.
14. Do not touch the heat sink or heat spreader when the system is running
15. Never pour any liquid into the openings. This could cause fire or electric shock.
16. As most electronic components are sensitive to static electrical charge, be sure to ground yourself to prevent static charge when installing the internal components. Use a grounding wrist strap and contain all electronic components in any static-shielded containers.

17. If any of the following situations arises, please the contact our service personnel:
  - i. Damaged power cord or plug
  - ii. Liquid intrusion to the device
  - iii. Exposure to moisture
  - iv. Device is not working as expected or in a manner as described in this manual
  - v. The device is dropped or damaged
  - vi. Any obvious signs of damage displayed on the device
18. **DO NOT LEAVE THIS DEVICE IN AN UNCONTROLLED ENVIRONMENT WHERE THE STORAGE TEMPERATURE IS BELOW -20° C (-4°F) OR ABOVE 60°C (140°F) TO PREVENT DAMAGE.**

### **Warning!**



This device complies with Part 15 FCC Rules. Operation is subject to the following two conditions: (1) this device may not cause harmful interference, and (2) this device must accept any interference received including interference that may cause undesired operation.

### **Caution:**

*There is a danger of explosion if the battery is incorrectly replaced. Replace only with the same or equivalent type recommended by the manufacturer. Dispose of used batteries according to the manufacturer's instructions and your local government's recycling or disposal directives.*

### **Attention:**

*Il y a un risque d'explosion si la batterie est remplacée de façon incorrecte. Ne la remplacer qu'avec le même modèle ou équivalent recommandé par le constructeur. Recycler les batteries usées en accord avec les instructions du fabricant et les directives gouvernementales de recyclage.*



## China RoHS Requirements (CN)

产品中有毒有害物质或元素名称及含量

AAEON Main Board/ Daughter Board/ Backplane

部件名称	有毒有害物质或元素					
	铅 (Pb)	汞 (Hg)	镉 (Cd)	六价铬 (Cr(VI))	多溴联苯 (PBB)	多溴二苯醚 (PBDE)
印刷电路板 及其电子组件	○	○	○	○	○	○
外部信号 连接器及线材	○	○	○	○	○	○

O: 表示该有毒有害物质在该部件所有均质材料中的含量均在 SJ/T 11363-2006 标准规定的限量要求以下。

X: 表示该有毒有害物质至少在该部件的某一均质材料中的含量超出 SJ/T 11363-2006 标准规定的限量要求。

备注: 此产品所标示之环保使用期限, 系指在一般正常使用状况下。

## China RoHS Requirement (EN)

Poisonous or Hazardous Substances or Elements in Products

AAEON Main Board/ Daughter Board/ Backplane

Component	Poisonous or Hazardous Substances or Elements					
	Lead (Pb)	Mercury (Hg)	Cadmium (Cd)	Hexavalent Chromium (Cr(VI))	Polybrominated Biphenyls (PBB)	Polybrominated Diphenyl Ethers (PBDE)
PCB & Other Components	○	○	○	○	○	○
Wires & Connectors for External Connections	○	○	○	○	○	○
<p>O: The quantity of poisonous or hazardous substances or elements found in each of the component's parts is below the SJ/T 11363-2006-stipulated requirement.</p> <p>X: The quantity of poisonous or hazardous substances or elements found in at least one of the component's parts is beyond the SJ/T 11363-2006-stipulated requirement.</p> <p><b>Note:</b> The Environment Friendly Use Period as labeled on this product is applicable under normal usage only</p>						

# Table of Contents

---

<b>Chapter 1 - Product Specifications</b> .....	<b>1</b>
1.1 Specifications .....	2
<b>Chapter 2 – Hardware Information</b> .....	<b>4</b>
2.1 Dimensions .....	5
2.2 Jumpers and Connectors.....	6
2.3 List of Jumpers .....	8
2.3.1 JP1: LVDS power.....	8
2.3.2 JP2: Backlight power.....	8
2.3.3 JP3: RS232 output power (Optional).....	9
2.3.4 JP4: Update image.....	9
2.3.5 JP5: Integrated3 (220-97-05GB01).....	9
2.3.6 JP6: Power button (220-96-02GB01) (Optional) .....	10
2.3.7 JP7/JP8: COM port setting .....	10
2.4 List of Connectors.....	11
2.4.1 CN3: WIFI Antenna (20279-001E) .....	12
2.4.2 CN4: LVDS (712-76-30GWE0).....	12
2.4.3 CN7: Debug port (712-71-09TW01).....	13
2.4.4 CN8: Giga LAN (RJL4A-4WH1-FP0-OR 90D(F)).....	13
2.4.5 CN9: USB (1201-700-08S) .....	13
2.4.6 CN11: Integrated 1 (710-73-09TW01).....	14
2.4.7 CN12: RS232 (220-97-05GB01) (Number: ttyXRUSB0) .....	14
2.4.8 CN14: eDP (20455-030E-12) .....	15
2.4.9 CN18: uSD (112J-TDAR-R) .....	16
2.4.10 CN21: USB OTG(TMC106-USBD05-835) .....	16
2.4.11 CN22: uSIM (SMHN-SO1(01T)) .....	16
2.4.12 CN23: RTC Battery .....	17

2.4.13	CN25: DC 12V Power .....	17
2.4.14	CN30: WWAN card slot (AS0B22x-S56Q-7H) .....	17
2.4.15	CN31: GPIO (220-97-05GB01).....	18
2.4.16	CN34: Backlight (721-81-05TW00).....	18
2.4.17	CN35: Speaker(712-H71-105W01) .....	19
2.4.18	CN37: MIPI (AYF333135).....	19
2.4.19	CN38: HDMI type A(QJ51191-LFB4-7F).....	20
2.4.20	CN40: RS232 (712-71-09TW01) (Number: ttyS1).....	20
2.5	Function Block.....	21
<b>Appendix A - Mating Connectors.....</b>		<b>22</b>
A.1	List of Mating Connectors and Cables.....	23

# Chapter 1

---

Product Specifications

## 1.1 Specifications

---

### System

Form Factor	Pico-ITX
CPU	Rockchip RK3288
CPU Frequency	ARM Cortex™-A17 Quad-core 1.6 GHz (up to 1.6 GHz)
Graphic	Video Decode: MPEG-1, MPEG-2, MPEG-4, H.263, H.264, AVS, VC-1, VP8, MVC Video Encode: H.264 (BP@level4.0, MP@level4.0, HP@level4.0), MVC and VP8
Memory Type	DDR3L 2GB
Max. Memory Capacity	16GB eMMC and Micro SD card
BIOS	—
Wake On LAN	—
Watchdog Timer	Integrated
Power Requirement	+12V DC input, Optional 7.4V battery
Power Supply Type	DC input
Power Consumption (Typical)	0.6A@12V, full load, Quad CPU
System Cooling	Fanless
Dimension	3.94" x 2.84" (100mm x 72mm)
Gross Weight	0.88 lb (0.4 kg)
Operating Temperature	32°F ~ 140°F (0°C ~ 60°C)

## System

Storage Temperature	-40°F ~ 176°F (-40°C ~ 80°C)
Operating Humidity	0% ~ 90% relative humidity, non-condensing
MTBF (Hours)	80,000
Certification	CE/FCC

## Display

Chipset	—
Resolution	HDMI(2.0) up to 4k x 2k @60Hz eDP up to 2560 x 1400 @60Hz LVDS (18/24-bit) up to 1400 x 900 @60Hz
LCD Interface	Dual LVDS, eDP and MIPI

## I/O

Storage/SSD	16GB eMMC and Micro SD card
Ethernet	GbE x 1
USB Port	Micro USB OTG x 1 Rear IO, USB 2.0 x 2 Rear IO
Serial Port	RS-232/422/485 x 1, RS-232 Pin header x 1
Audio	2.5W (by 4Ω) Speaker/ Microphone/ Earphone
GPIO	8-bit (4-in, 4-out)
Expansion Slot	Full-size mini-PCIe slot x 1 (For 3G/4G card)
SIM slot	Nano-SIM
USB	USB 2.0 x 1 pin header
Camera	MIPI Camera/ USB Camera
Touch	I2C interface/ USB Touch

# Chapter 2

---

Hardware Information





## 2.2 Jumpers and Connectors

### Component side

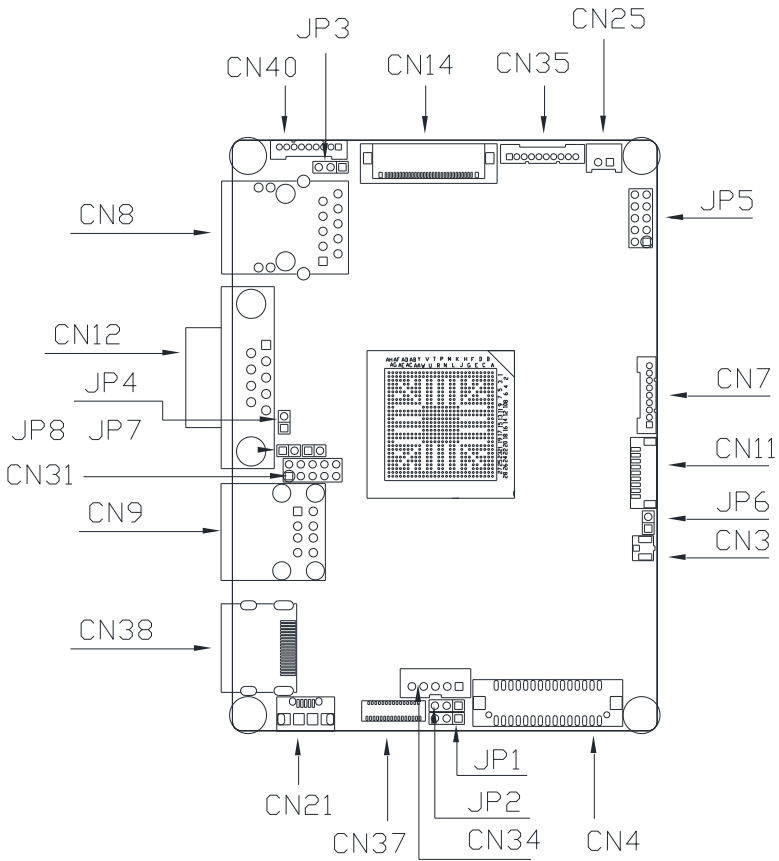

Solder side

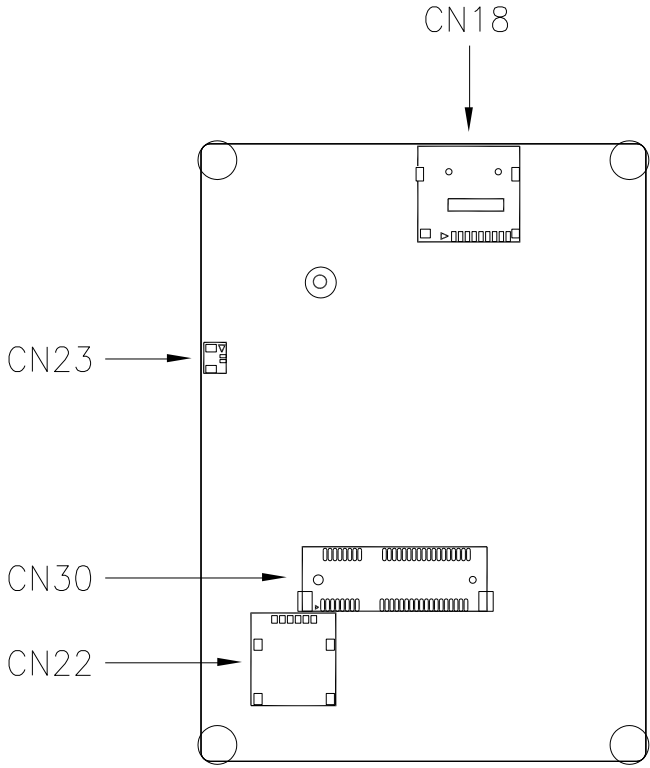

## 2.3 List of Jumpers

---

Please refer to the table below for all of the board's jumpers that you can configure for your application

Label	Function
JP1	LVDS Power
JP2	Backlight Power
JP3	RS232 output power
JP4	Update image
JP5	Integrated3
JP6	Power Button(Optional)
JP7/8	COM Port Setting

### 2.3.1 JP1: LVDS power

---

Pin	Definition
1-2	+5V
2-3	+3.3V (Default)

### 2.3.2 JP2: Backlight power

---

Pin	Definition
1-2	+5V (Default)
2-3	+12V

### 2.3.3 JP3: RS232 output power (Optional)

---

Pin	Definition
1-2	+12V
2-3	+5V

### 2.3.4 JP4: Update image

---

Mode	JP4
Normal mode	Open
Update image	Short

### 2.3.5 JP5: Integrated3 (220-97-05GB01)

---

Pin	Definition	Pin	Definition
1	+3.3V	6	I2C1_CLK
2	Battery Detect	7	GND
3	UART4_TX	8	I2C1_DATA
4	Disable charger	9	GPIO
5	UART4_RX	10	GPIO

### 2.3.6 JP6: Power button (220-96-02GB01) (Optional)

---

Pin	Definition
1	GND
2	Reserve

### 2.3.7 JP7/JP8: COM port setting

---

Mode	JP7	JP8
RS485	Open	Open
RS232	Short (Default)	Open (Default)
RS422	Short	Short

## 2.4 List of Connectors

Please refer to the table below for all of the board's connectors that you can configure for your application

Label	Function	Vendor	Model No.
CN3	WiFi Antenna	I-PEX	20279-001E
CN4	LVDS connector	PINREX	712-76-30GWE0
CN7	Debug Port	PINREX	712-71-09TW01
CN8	Giga LAN	SPEEDTECH	RJL4A-4WH1-FP0-0R
CN9	USB	Techbest	KS-002-AB-L
CN11	Integrated	PINREX	710-H73-095WE1
CN12	RS232 Port	Hobase	D-SUB 5m/m-9P
CN14	eDP connector	I-PEX	20455-030E-12
CN18	Micro SD card slot	ATTEND	112J-TDAR-R01
CN21	USB OTG port	TRONTEK	TMC106-USBD05-835
CN22	Nano-SIM slot	SUNFUN	SMHN-SO1(01T)
CN23	RTC Battery	ACES	50208-00201-001
CN25	DC Power Input	CATCH	1192-700-02S
CN30	WWAN card slot	FOXCONN	AS0B22x-S56Q-7H
CN31	GPIO port	PINREX	220-97-05GB01
CN34	Panel Backlight Connector	PINREX	721-81-05TW00
CN35	Speaker	PINREX	712-H71-105W01
CN37	MIPI connector	Panasonic	AYF333135
CN38	HDMI connector	FOXCONN	QJ51191-LFB4-7F
CN40	RS232 port	PINREX	712-71-09TW01

## 2.4.1 CN3: WIFI Antenna (20279-001E)

---

Standard specifications.

## 2.4.2 CN4: LVDS (712-76-30GWE0)

---

Pin	Definition	Pin	Definition	Pin	Definition
1	BKL_ENABLE	11	LVDS_DA1-	21	LVDS_DA6-
2	BKL_CONTROL	12	LVDS_DA1+	22	LVDS_DA6+
3	LCD_PWR	13	LVDS_DA2-	23	LVDS_DA7-
4	GND	14	LVDS_DA2+	24	LVDS_DA7+
5	LVDS_A_CLK-	15	LVDS_DA3-	25	LVDS_DA8-
6	LVDS_A_CLK+	16	LVDS_DA3+	26	LVDS_DA8+
7	LCD_PWR	17	DDC_DATA	27	LCD_PWR
8	GND	18	DDC_CLK	28	GND
9	LVDS_DA0-	19	LVDS_DA5-	29	LVDS_B_CLK-
10	LVDS_DA0+	20	LVDS_DA5+	30	LVDS_B_CLK+



### 2.4.3 CN7: Debug port (712-71-09TW01)

---

Pin	Definition	Pin	Definition
1	N.C	6	N.C
2	N.C	7	N.C
3	RX	8	N.C
4	N.C	9	GND
5	TX		

### 2.4.4 CN8: Giga LAN (RJL4A-4WH1-FP0-OR 90D(F))

---

Pin	Definition	Pin	Definition
1	TX+_D1	5	BI-_D3
2	TX-_D1	6	RX-_D2
3	RX+_D2	7	BI+_D4
4	BI+_D3	8	BI-_D4

### 2.4.5 CN9: USB (1201-700-08S)

---

Pin	Definition	Pin	Definition
1	+5V	5	+5V
2	USB2_D-	6	USB3_D-
3	USB2_D+	7	USB3_D+
4	GND	8	GND

## 2.4.6 CN11: Integrated 1 (710-73-09TW01)

Pin	Definition	Pin	Definition
1	I2C4_CLK	6	USB1_D-
2	I2C4_DATA	7	I2C3_CLK
3	GND	8	I2C3_DATA
4	+5V	9	NFC_DFU
5	USB1_D+		

## 2.4.7 CN12: RS232 (220-97-05GB01) (Number: ttyXRUSB0)

Pin	Definition	Pin	Definition
1	DCD	6	DSR
2	RX	7	RTS
3	TX	8	CTS
4	DTR	9	V out(refer to JP3)
5	GND		

Pin	Definition	Pin	Definition
1	RS485_D-(B)	6	N.C
2	RS485_D+(A)	7	N.C
3	N.C	8	N.C
4	N.C	9	N.C
5	N.C		

*Continued on Next Page*

Pin	Definition	Pin	Definition
1	RS422_TX-(B)	6	N.C
2	RS422_TX+(A)	7	N.C
3	RS422_RX+(A)	8	N.C
4	RS422_RX-(B)	9	N.C
5	N.C		

## 2.4.8 CN14: eDP (20455-030E-12)

Pin	Definition	Pin	Definition	Pin	Definition
1	GND	11	GND	21	eDP_HPDP
2	eDP_TX0-	12	LCD_PWR	22	BKL_ENABLE
3	eDP_TX0+	13	LCD_PWR	23	BKL_CONTROL
4	GND	14	eDP_TX3-	24	GND
5	eDP_TX1-	15	eDP_TX3+	25	GND
6	eDP_TX1+	16	GND	26	BKL_PWR (Refer to JP2)
7	GND	17	eDP_AUX-	27	BKL_PWR (Refer to JP2)
8	eDP_TX2-	18	eDP_AUX+	28	BKL_PWR (Refer to JP2)
9	eDP_TX2+	19	GND	29	BKL_PWR (Refer to JP2)
10	GND	20	GND	30	GND

### 2.4.9 CN18: uSD (112J-TDAR-R)

Pin	Definition	Pin	Definition
1	DAT2	6	GND
2	DAT3	7	DAT0
3	CMD	8	DAT1
4	+3.3V	9	CD
5	CLK	10	GND

### 2.4.10 CN21: USB OTG(TMC106-USBD05-835)

Pin	Definition
1	+5V
2	OTG_USB_D-
3	OTG_USB_D+
4	OTG_ID
5	GND

### 2.4.11 CN22: uSIM (SMHN-SO1(01T))

Pin	Definition	Pin	Definition
C1	USIM_PWR	C5	GND
C2	USIM_RESET	C6	N.C
C3	USIM_CLK	C7	USIM_DATA

## 2.4.12 CN23: RTC Battery

---

Pin	Definition
1	+3.3V
2	GND

## 2.4.13 CN25: DC 12V Power

---

Pin	Definition
1	GND
2	+12V

## 2.4.14 CN30: WWAN card slot (AS0B22x-S56Q-7H)

---

Pin	Definition	Pin	Definition	Pin	Definition	Pin	Definition
1	WAKE_UP	14	USIM_RESET	27	GND	40	GND
2	+3.3V	15	GND	28	N.C	41	+3.3V
3	N.C	16	N.C	29	GND	42	N.C
4	GND	17	WAKE_UP_OUT	30	N.C	43	GND
5	N.C	18	GND	31	N.C	44	N.C
6	N.C	19	N.C	32	N.C	45	N.C
7	N.C	20	DISABLE	33	N.C	46	N.C
8	USIM_PWR	21	GND	34	GND	47	N.C
9	GND	22	RESET	35	N.C	48	N.C

Pin	Definition	Pin	Definition	Pin	Definition	Pin	Definition
10	USIM_DATA	23	N.C	36	USB1_D-	49	N.C
11	N.C	24	+3.3V	37	GND	50	GND
12	USIM_CLK	25	N.C	38	USB1_D+	51	N.C
13	N.C	26	GND	39	+3.3V	52	+3.3V

#### 2.4.15 CN31: GPIO (220-97-05GB01)

Pin	Definition	Pin	Definition
1	GPIO1_60	6	GPIO6_58
2	GPIO2_56	7	GPIO7_63
3	GPIO3_61	8	GPIO8_59
4	GPIO4_57	9	+3.3V
5	GPIO5_62	10	GND

#### 2.4.16 CN34: Backlight (721-81-05TW00)

Pin	Definition
1	BKL_PWR (Refer to JP2)
2	BKL_CONTROL
3	GND
4	GND
5	BKL_ENABLE

## 2.4.17 CN35: Speaker(712-H71-105W01)

Pin	Definition
1	GND
2	MIC
3	HP_DET
4	GND
5	LEFT_OUT
6	RIGHT_OUT
7	Spk_L_P
8	Spk_L_N
9	Spk_R_P
10	Spk_R_N

## 2.4.18 CN37: MIPI (AYF333135)

Pin	Definition	Pin	Definition	Pin	Definition	Pin	Definition
1	TP_VDD_2V8	11	FB1	21	GND	31	MIPI0+
2	TP_GND	12	FB1	22	MIPI2+	32	MIPI0-
3	TP_RESET	13	FB1	23	MIPI2-	33	GND
4	TP_SCL_1V8	14	NC	24	GND	34	GND
5	TP_SDA_1V8	15	GND	25	MIPI_CLK+	35	RESET_1_8V
6	TP_INT_1V8	16	GND	26	MIPI_CLK-	36	LOGIC_1_8V
7	NC	17	LCDID	27	GND	37	VCC_3_3V
8	VLED	18	GND	28	MIPI1+	38	VCC_3_3V
9	VLED	19	MIPI3+	29	MIPI1-	39	FMARK
10	NC	20	MIPI3-	30	GND		

## 2.4.19 CN38: HDMI type A(QJ51191-LFB4-7F)

---

Pin	Definition	Pin	Definition
1	HDMI_TX2P	11	GND
2	GND	12	HDMI_CLKN
3	HDMI_TX2N	13	HDMI_CEC
4	HDMI_TX1P	14	N.C
5	GND	15	DDC_SCL
6	HDMI_TX1N	16	DDC_SDA
7	HDMI_TX0P	17	GND
8	GND	18	+5V
9	HDMI_TX0N	19	HDMI_HPD
10	HDMI_CLKP		

## 2.4.20 CN40: RS232 (712-71-09TW01) (Number: ttyS1)

---

Pin	Definition	Pin	Definition
1	N.C	6	CTS
2	N.C	7	N.C
3	RX	8	N.C
4	RTS	9	GND
5	TX		



## 2.5 Function Block

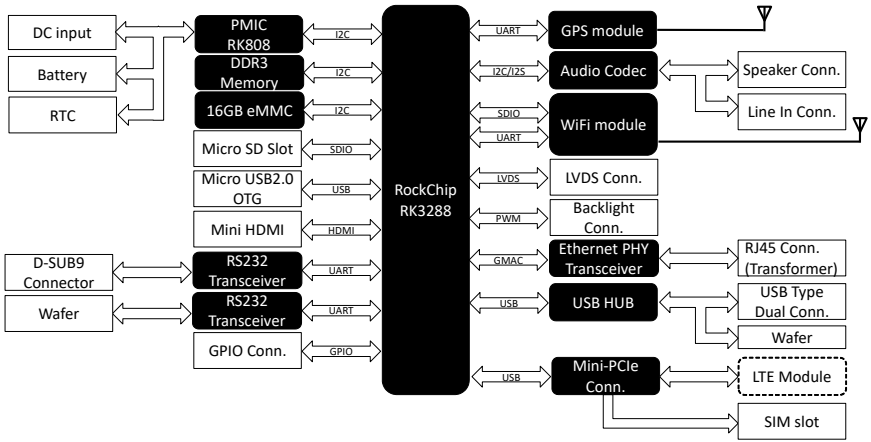

# Appendix A

---

Mating Connectors

## A.1 List of Mating Connectors and Cables

Connector Label	Function	Mating Connector		Available Cable	Cable P/N
		Vendor	Model no		
CN3	WiFi Antenna	I-PEX	20279-001E	RF Coaxial cable	1700010252
CN4	LVDS connector	PINREX	712-76-30G WE0	N/A	N/A
CN7	Debug Port	PINREX	712-71-09T W01	D-sub9 console cable	1701090150
CN8	Giga LAN	SPEEDTECH	RJ45-4W H1-FP0-0R	N/A	N/A
CN9	USB	Techbest	KS-002-AB-L	N/A	N/A
CN11	Integrated	PINREX	710-H73-09 5WE1	N/A	N/A
CN12	RS232 Port	Hobase	D-SUB 5m/m-9P	N/A	N/A
CN14	eDP connector	I-PEX	20455-030E -12	N/A	N/A
CN18	Micro SD card slot	ATTEND	112J-TDAR-R01	N/A	N/A
CN21	USB OTG port	TRONTEK	TMC106-US BD05-835	N/A	N/A
CN22	Nano-SIM slot	SUNFUN	SMHN-SO1(01T)	N/A	N/A
CN23	RTC Battery	ACES	50208-0020 1-001	N/A	N/A

CN25	DC Power Input	CATCH	1192-700-02 S	N/A	N/A
CN30	WWAN card slot	FOXCONN	AS0B22x-S5 6Q-7H	N/A	N/A
CN31	GPIO port	PINREX	220-97-05G B01	N/A	N/A
CN34	Panel Backlight Connector	PINREX	721-81-05T W00	N/A	N/A
CN35	Speaker	PINREX	712-H71-105 W01	N/A	N/A
CN37	MIPI connector	Panasonic	AYF333135	N/A	N/A
CN38	HDMI connector	FOXCONN	QJ51191-LFB 4-7F	N/A	N/A
CN40	RS232 port	PINREX	712-71-09T W01	D-sub9 COM port console cable	1701090150