



# PICO-ADN4-SEMI

---

PICO-SEMI System

User's Manual 1<sup>st</sup> Ed

## Copyright Notice

---

This document is copyrighted, 2025. All rights are reserved. The original manufacturer reserves the right to make improvements to the products described in this manual at any time without notice.

No part of this manual may be reproduced, copied, translated, or transmitted in any form or by any means without the prior written permission of the original manufacturer. Information provided in this manual is intended to be accurate and reliable. However, the original manufacturer assumes no responsibility for its use, or for any infringements upon the rights of third parties that may result from its use.

The material in this document is for product information only and is subject to change without notice. While reasonable efforts have been made in the preparation of this document to assure its accuracy, AAEON assumes no liabilities resulting from errors or omissions in this document, or from the use of the information contained herein.

AAEON reserves the right to make changes in the product design without notice to its users.

## Acknowledgement

---

All other products' name or trademarks are properties of their respective owners.

- Microsoft Windows® is a registered trademark of Microsoft Corp.
- Intel® and Atom® are registered trademarks of Intel Corporation
- ITE is a trademark of Integrated Technology Express, Inc.
- IBM, PC/AT, PS/2, and VGA are trademarks of International Business Machines Corporation.
- Ubuntu and Canonical are registered trademarks of Canonical Ltd.
- Linux® is the registered trademark of Linus Torvalds in the U.S. and other countries.
- Realtek is a trademark of Realtek Semiconductor Corporation

All other product names or trademarks are properties of their respective owners.

Omission of a product name from this list does not imply any claim to ownership by the publisher of this document.

## Packing List

---

Before setting up your product, please make sure the following items have been shipped:

Item	Quantity
● PICO-ADN4-SEMI	1

If any of these items are missing or damaged, please contact your distributor or sales representative immediately.

## About this Document

---

This User's Manual contains all the essential information, such as detailed descriptions and explanations on the product's hardware and software features (if any), its specifications, dimensions, jumper/connector settings/definitions, and driver installation instructions (if any), to facilitate users in setting up their product.

Users may refer to the product page on [AAEON.com](http://AAEON.com) for the latest version of this document.

## Safety Precautions

---

Please read the following safety instructions carefully. It is advised that you keep this manual for future references

1. All cautions and warnings on the device should be noted.
2. Make sure the power source matches the power rating of the device.
3. Position the power cord so that people cannot step on it. Do not place anything over the power cord.
4. Always completely disconnect the power before working on the system's hardware.
5. No connections should be made when the system is powered as a sudden rush of power may damage sensitive electronic components.
6. If the device is not to be used for a long time, disconnect it from the power supply to avoid damage by transient over-voltage.
7. Always disconnect this device from any AC supply before cleaning.
8. While cleaning, use a damp cloth instead of liquid or spray detergents.
9. Make sure the device is installed near a power outlet and is easily accessible.
10. Keep this device away from humidity.
11. Place the device on a solid surface during installation to prevent falls
12. Do not cover the openings on the device to ensure optimal heat dissipation.
13. Watch out for high temperatures when the system is running.
14. Do not touch the heat sink or heat spreader when the system is running
15. Never pour any liquid into the openings. This could cause fire or electric shock.
16. As most electronic components are sensitive to static electrical charge, be sure to ground yourself to prevent static charge when installing the internal components. Use a grounding wrist strap and contain all electronic components in any static-shielded containers.

17. If any of the following situations arises, please the contact our service personnel:
  - i. Damaged power cord or plug
  - ii. Liquid intrusion to the device
  - iii. Exposure to moisture
  - iv. Device is not working as expected or in a manner as described in this manual
  - v. The device is dropped or damaged
  - vi. Any obvious signs of damage displayed on the device
18. **DO NOT LEAVE THIS DEVICE IN AN UNCONTROLLED ENVIRONMENT WHERE THE STORAGE TEMPERATURE IS BELOW -20° C (-4°F) OR ABOVE 60°C (140°F) TO PREVENT DAMAGE.**

### **Warning!**



This device complies with Part 15 FCC Rules. Operation is subject to the following two conditions: (1) this device may not cause harmful interference, and (2) this device must accept any interference received including interference that may cause undesired operation.

### **Caution:**

*There is a danger of explosion if the battery is incorrectly replaced. Replace only with the same or equivalent type recommended by the manufacturer. Dispose of used batteries according to the manufacturer's instructions and your local government's recycling or disposal directives.*

### **Attention:**

*Il y a un risque d'explosion si la batterie est remplacée de façon incorrecte. Ne la remplacer qu'avec le même modèle ou équivalent recommandé par le constructeur. Recycler les batteries usées en accord avec les instructions du fabricant et les directives gouvernementales de recyclage.*

## 产品中有毒有害物质或元素名称及含量

AAEON System

QO4-381 Rev.A2

部件名称	有毒有害物质或元素					
	铅 (Pb)	汞 (Hg)	镉 (Cd)	六价铬 (Cr(VI))	多溴联苯 (PBB)	多溴二苯醚 (PBDE)
印刷电路板 及其电子组件	×	○	○	○	○	○
外部信号 连接器及线材	×	○	○	○	○	○
外壳	○	○	○	○	○	○
中央处理器 与内存	×	○	○	○	○	○
硬盘	×	○	○	○	○	○
液晶模块	×	○	○	○	○	○
光驱	×	○	○	○	○	○
触控模块	×	○	○	○	○	○
电源	×	○	○	○	○	○
电池	×	○	○	○	○	○

本表格依据 SJ/T 11364 的规定编制。

○：表示该有毒有害物质在该部件所有均质材料中的含量均在 GB/T 26572 标准规定的限量要求以下。

×：表示该有害物质的某一均质材料超出了 GB/T 26572 的限量要求，然而该部件仍符合欧盟指令 2011/65/EU 的规范。

环保使用期限(EFUP (Environmental Friendly Use Period))：10 年

备注：

一、此产品所标示之环保使用期限，系指在一般正常使用状况下。

二、上述部件物质中央处理器、内存、硬盘、光驱、电源为选购品。

三、上述部件物质液晶模块、触控模块仅一体机产品适用。

## China RoHS Requirement (EN)

### Name and content of hazardous substances in product

AAEON System

QO4-381 Rev.A2

Part Name	Hazardous Substances					
	铅 (Pb)	汞 (Hg)	镉 (Cd)	六价铬 (Cr(VI))	多溴联苯 (PBB)	多溴二苯醚 (PBDE)
PCB Assemblies	×	○	○	○	○	○
Connector and Cable	×	○	○	○	○	○
Chassis	○	○	○	○	○	○
CPU and Memory	×	○	○	○	○	○
Hard Disk	×	○	○	○	○	○
LCD Modules	×	○	○	○	○	○
CD-ROM/DVD-ROM	×	○	○	○	○	○
Touch Modules	×	○	○	○	○	○
Power	×	○	○	○	○	○
Battery	×	○	○	○	○	○

The table is prepared in accordance with the provisions of SJ/T 11364.

○ : Indicates that said hazardous substance contained in all of the homogenous materials for this product is below the limit requirement of GB/T 26572.

× : Indicates that said hazardous substance contained in at least one of the homogenous materials used for this part is above the limit requirement of GB/T 26572. But this product still be compliance with 2011/65/EU Directive (allowed with 2011/65/EU Annex III of RoHS exemption with number 6(c),7(a),7(c)-1).

EFUP (Environment Friendly Use Period) value: 10 years.

Notes:

1. This product defined period of use is under normal condition.
2. In above part, CPU/Memory/ Hard Disk/CD-ROM/DVD-ROM/ Power are optional.
3. In above part, LCD Modules/ Touch Modules are for all-in-one product model.

## Table of Contents

---

<b>Chapter 1 - Product Specifications</b> .....	<b>1</b>
1.1 Specifications.....	2
1.2 Function Block Diagram.....	5
<b>Chapter 2 – Hardware Information</b> .....	<b>6</b>
2.1 Dimensions.....	7
2.2 Jumpers and Connectors .....	9
2.3 List of Jumpers.....	11
2.3.1 Clear CMOS Jumper & Auto Power Button Enable/Disable (JP1) .....	11
2.4 List of Connectors .....	12
2.4.1 RTC Battery Connector (CN1) .....	13
2.4.2 HDMI (CN2) .....	13
2.4.3 Dual RJ-45 LAN (CN5) .....	14
2.4.4 Mini Card/mSATA (CN9).....	15
2.4.5 Dual USB 3.2 Port (CN11) .....	17
2.4.6 SPI (For BIOS) (CN15).....	18
2.4.7 4-Pin Fan (CN16).....	18
2.4.8 I2C/SMBus (CN17) .....	19
2.4.9 eSPI Debug Connector (CN18).....	20
2.4.10 M.2 2230 E-Key (CN19) .....	21
2.4.11 Front Panel (CN22).....	23
2.4.12 +9V - 36V Power Input (CN23).....	24
2.4.13 Vcore Programing Connector (CN25).....	24
2.4.14 Audio Connector (CN28).....	25
2.4.15 4-bit GPIO (CN31) .....	25
2.4.16 COM 1 ~ 2 Connector (CN32).....	26
2.4.17 DDR5 SODIMM (DIMM1) .....	27

2.5	Hardware Installation.....	28
2.5.1	Wall Mount Kit.....	28
2.5.2	DIN Rail Kit.....	29
<b>Chapter 3 - AMI BIOS Setup .....</b>		<b>30</b>
3.1	System Test and Initialization .....	31
3.2	AMI BIOS Setup.....	32
3.3	Setup Submenu: Main.....	33
3.4	Setup Submenu: Advanced .....	34
3.4.1	CPU Configuration .....	35
3.4.2	PCH-FW Configuration .....	36
3.4.2.1	Firmware Update Configuration.....	37
3.4.3	PTT Configuration.....	38
3.4.4	Trusted Computing .....	39
3.4.5	Hardware Monitor.....	41
3.4.5.1	Smart Fan Mode Configuration.....	42
3.4.6	SIO Configuration .....	43
3.4.6.1	Serial Port 1 Configuration.....	44
3.4.6.2	Serial Port 2 Configuration .....	45
3.4.7	Serial Port Console Redirection.....	46
3.4.7.1	Legacy Console Redirection Settings .....	47
3.4.8	AAEON BIOS Robot.....	48
3.4.8.1	Device Detecting Configuration .....	50
3.4.9	Power Management .....	56
3.4.10	GPIO Port Configuration.....	57
3.5	Setup Submenu: Chipset.....	58
3.5.1	System Agent (SA) Configuration .....	59
3.5.1.1	Memory Configuration .....	60
3.5.2	PCH-IO Configuration.....	61

3.6	Setup Submenu: Security .....	62
3.6.1	Secure Boot .....	63
3.6.1.1	Key Management .....	64
3.7	Setup Submenu: Boot .....	66
3.7.1	BBS Priorities.....	67
3.8	Setup Submenu: Save & Exit .....	68
<b>Chapter 4 – Drivers Installation.....</b>		<b>69</b>
4.1	Drivers Download and Installation .....	70
<b>Appendix A – Mating Connectors .....</b>		<b>72</b>
A.1	List of Mating Connectors and Cables .....	73
<b>Appendix B - I/O Information .....</b>		<b>74</b>
B.1	I/O Address Map .....	75
B.2	IRQ Mapping Chart .....	76
B.3	Large Memory Map.....	85
B.4	Memory Address Map.....	86
<b>Appendix C - Watchdog Timer Programming.....</b>		<b>88</b>
C.1	Introduction to Watchdog Timer .....	89
C.2	Programing the Watchdog Timer with AAEON SDK.....	90
C.3	Programing Watchdog Timer with AAEON Windows EAPI.....	91
C.3.1	Watchdog Timer Functions .....	92
C.3.1.1	EapiWDogGetCap().....	92
C.3.1.2	EapiWDogStart() .....	93
C.3.1.3	EapiWDogTrigger() .....	94
C.3.1.4	EapiWDogStop() .....	94
C.3.1.5	EapiWDogReloadTimer() .....	95
C.3.1.6	EapiWDogGetStatus() .....	95
C.3.1.7	EapiWDogSetStatus().....	96

# Chapter 1

---

Product Specifications

## 1.1 Specifications

---

### System

Form Factor	PICO-SEMI
CPU	Intel® Processor and Intel® Core™ 3 N-series Processors: Intel® Processor N97 (4C/4T, 2.00 GHz, 12W) Intel® Core™ i3-N305 Processor (8C/8T, 1.80 GHz, 15W)
Chipset	Integrated with Intel® SoC
Memory Type	DDR5 4800, Single-Channel SODIMM x 1, Max 16GB, Non-ECC
BIOS	UEFI
Wake on LAN	Yes
Watchdog Timer	255 Levels
Security	TPM 2.0
RTC Battery	Lithium Battery 3V/240mAh
Dimension	5.51" x 3.94" x 1.69" (140mm x 100mm x 43mm)
Gross Weight	1.55 lb (0.70 kg)
OS Support	Windows® 10 (64-bit) Ubuntu 22.04.2/Kernel 5.19

### Power

Power Requirement	+9V - 36V (Optional: 12V)
Power Supply Type	ATX
Connector	Lockable DC Jack Connector
Power Consumption	Intel® Core™ i3-N305, DDR5 16GB x 1, 2.43A @+12V (Typical) Intel® Core™ i3-N305, DDR5 16GB x 1, 3.63A @+12V (Max)

## Display

Controller	Intel® UHD Graphics for 12th Gen Intel® Processors
LVDS/eDP	—
Display Interface	HDMI 1.4 x 1, 3840 x 2160 @30Hz
Multiple Display	Single Display

## Audio

Codec	Realtek ALC256 (Optional)
Audio Interface	Line-out (Optional)
Speaker	—

## External I/O

Ethernet	Intel® Ethernet Controller I226 2.5GbE, RJ-45 x 1 Realtek. RTL8111H-CG, 1GbE, RJ-45 x 1,
USB	USB 3.2 Gen 2 x 2
Serial Port	COM x 2 (RS-232/422/485, support 5V/12V/RI, Optional)
Video	HDMI 1.4 x 1

## Internal I/O

USB	—
Serial Port	—
Video	—
SATA	—
Audio	Line-out Header x 1 (Optional)
DIO/GPIO	GPIO 4-bit (Optional)
SMBus/I2C	SMBus/I2C x 1 (Default: SMBus)
Fan	4-pin Smart Fan x1
Front Panel	HDD LED, PWR LED, Power Button, Buzzer, Reset

**Expansion**

<b>Mini PCIe/mSATA</b>	Full-size mSATA/mPCIe x 1 (default: mSATA, select with BIOS)
<b>M.2</b>	M.2 2230 E-Key x 1
<b>Others</b>	—

**Environmental**

<b>Operating Temperature</b>	Default: 32°F – 122°F (0°C – 50°C) with 0.7m/s air flow Optional: -40°F – 122°F (-40°C – 50°C)
<b>Storage Temperature</b>	-40°F – 185°F (-40°C – 85°C)
<b>Operating Humidity</b>	0% – 90% relative humidity, non-condensing
<b>MTBF (Hours)</b>	2,219,397
<b>EMC</b>	CE/FCC Class A

## 1.2 Function Block Diagram

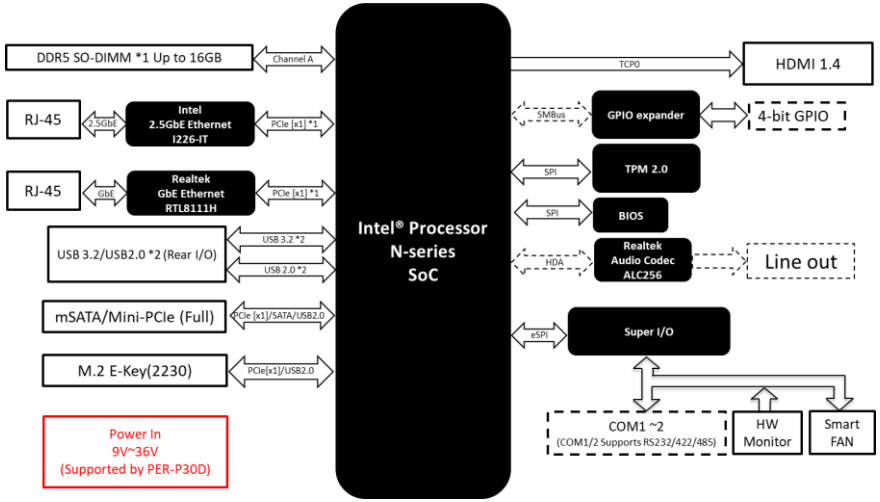

# Chapter 2

---

Hardware Information

## 2.1 Dimensions

### System

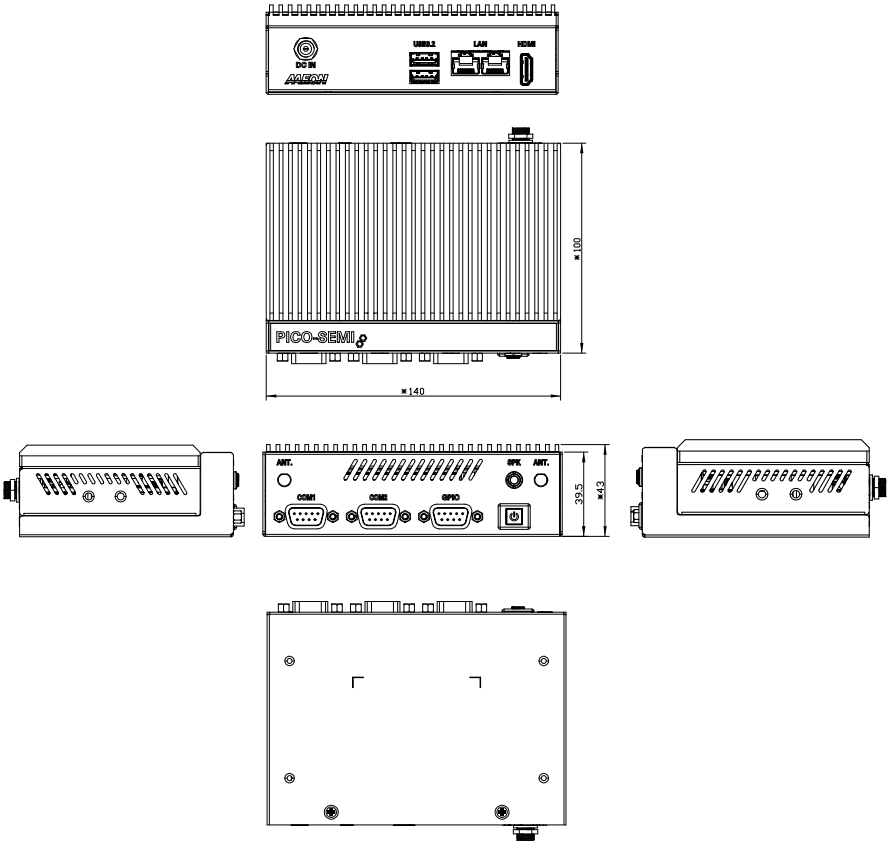

# Board

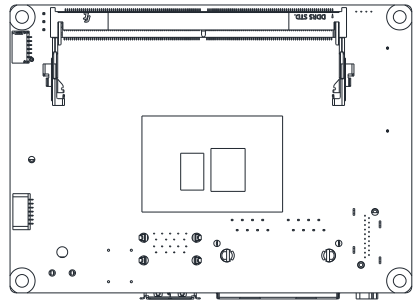
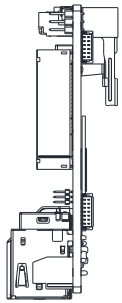
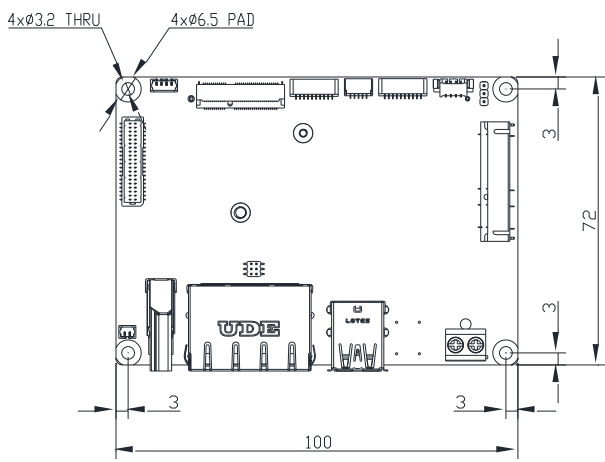

## 2.2 Jumpers and Connectors

### Top View

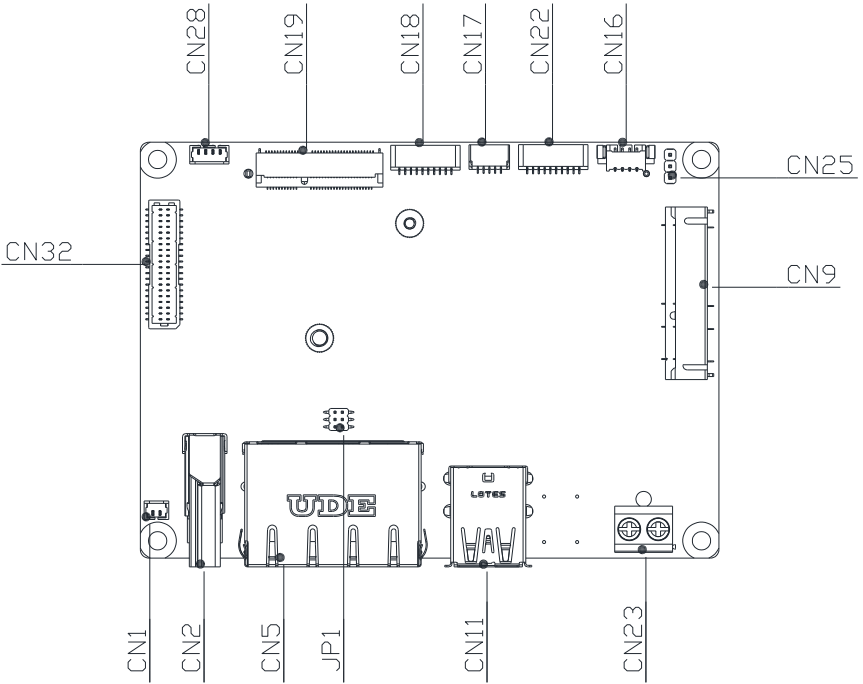

### Bottom View

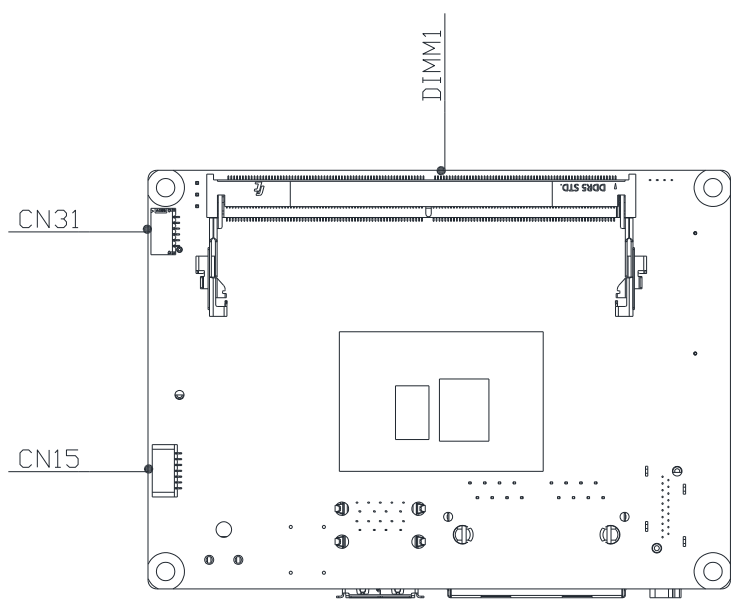

## 2.3 List of Jumpers

Jumpers allow users to manually customize system configurations to their suitable application needs.

Please refer to the table below for all of the board's jumpers that you can configure for your application

Label	Function
JP1	Clear CMOS Jumper & Auto Power Button Enable/Disable

### 2.3.1 Clear CMOS Jumper & Auto Power Button Enable/Disable (JP1)

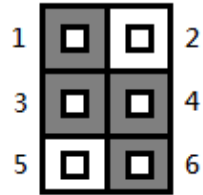
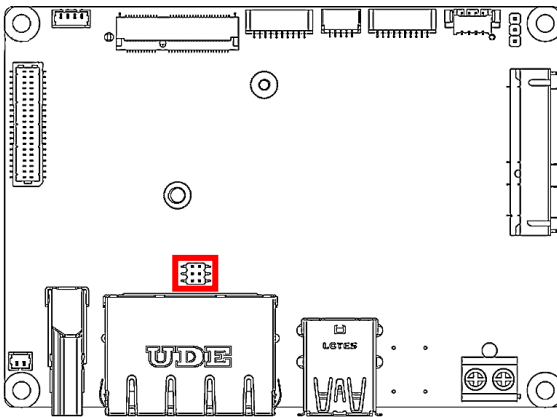

Clear CMOS Jumper	
Pin	Function
1-3	Save CMOS ( <b>Default</b> )
3-5	Clear CMOS

Auto Power Button Enable/Disable	
Pin	Function
2-4	Disable ( <b>Default</b> )
4-6	Enable

## 2.4 List of Connectors

---

Please refer to the table below for all of the board's connectors that you can configure for your application

Label	Function
CN1	RTC Battery Connector
CN2	HDMI
CN5	Dual RJ-45 LAN (Left I226-V/Right RTL8111H-CG)
CN9	Mini Card/mSATA
CN11	Dual USB 3.2 Port
CN15	SPI (For BIOS)
CN16	4-Pin Fan
CN17	I2C/SMBus
CN18	eSPI Debug Connector
CN19	M.2 2230 E-Key
CN22	Front Panel
CN23	+9V - 36V Power Input
CN25	Vcore Programing Connector
CN28	Audio Connector
CN31	4-bit GPIO
CN32	COM Connector (RS-232/422/485 x 2)
DIMM1	DDR5 SODIMM

### 2.4.1 RTC Battery Connector (CN1)

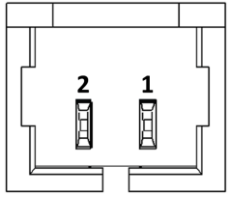
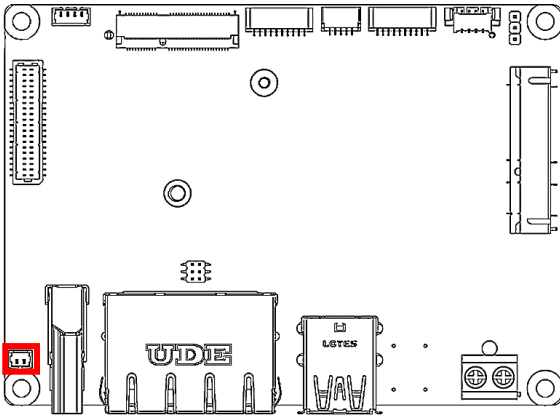

Pin	Pin Name	Signal Type	Signal Level
1	+3.3V	PWR	+3.3V
2	GND	GND	

### 2.4.2 HDMI (CN2)

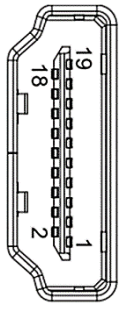
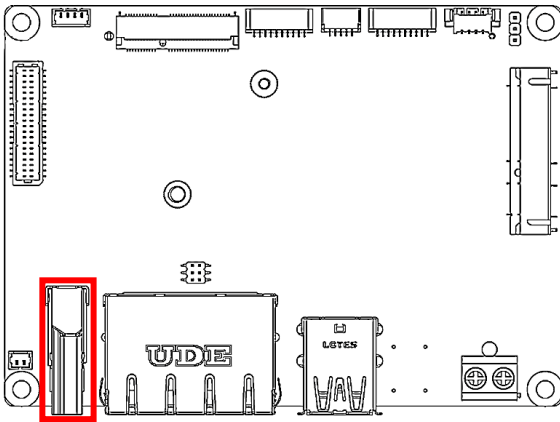

Pin	Pin Name	Signal Type	Signal Level
1	HDMI_TX2+	DIFF	
2	GND	GND	
3	HDMI_TX2-	DIFF	
4	HDMI_TX1+	DIFF	
5	GND	GND	

Pin	Pin Name	Signal Type	Signal Level
6	HDMI_TX1-	DIFF	
7	HDMI_TX0+	DIFF	
8	GND	GND	
9	HDMI_TX0-	DIFF	
10	HDMI_CLK+	DIFF	
11	GND	GND	
12	HDMI_CLK-	DIFF	
13	NC		
14	NC		
15	DDC_CLK	Signal	+5V
16	DDC_DATA	Signal	+5V
17	GND	GND	
18	+5V	PWR	+5V
19	HDMI_HPD		

### 2.4.3 Dual RJ-45 LAN (CN5)

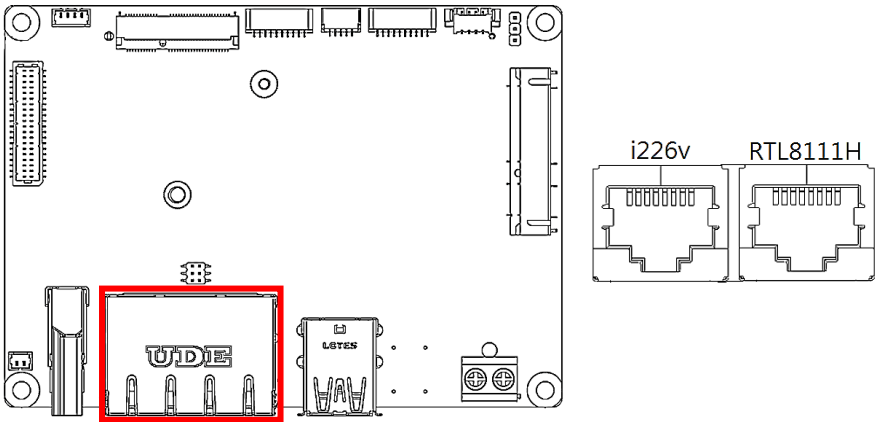

Pin	Pin Name	Pin	Pin Name
1P1	LAN2_MDIO_P	2P1	LAN1_MDIO_P
1P2	LAN2_MDIO_N	2P2	LAN1_MDIO_N
1P3	LAN2_MDI1_P	2P3	LAN1_MDI1_P
1P4	LAN2_MDI1_N	2P4	LAN1_MDI1_N
1P5	1CT5	2P5	2CT5
1P6	1CT6	2P6	2CT6
1P7	LAN2_MDI2_P	2P7	LAN1_MDI2_P
1P8	LAN2_MDI2_N	2P8	LAN1_MDI2_N

Pin	Pin Name	Pin	Pin Name
1P9	LAN2_MDIO_P	2P9	LAN1_MDIO_P
1P10	LAN2_MDIO_N	2P10	LAN1_MDIO_N

### 2.4.4 Mini Card/mSATA (CN9)

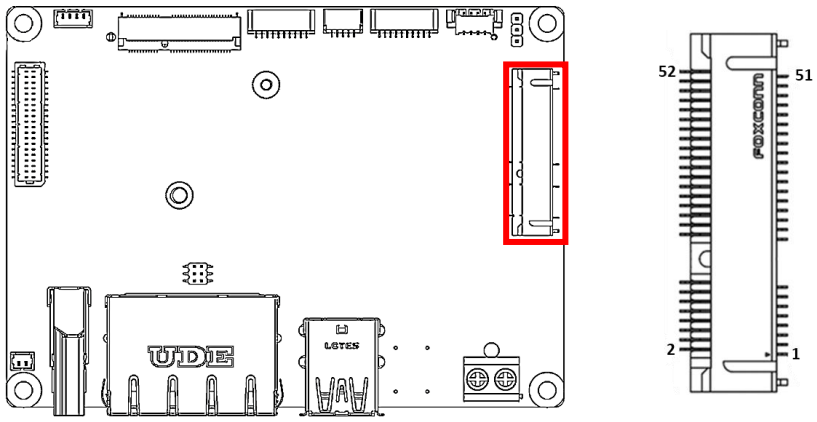

Pin	Pin Name	Signal Type	Signal Level
1	PCIE_WAKE#	Signal	
2	+3.3V	PWR	+3.3V
3	NC		
4	GND	GND	
5	NC		
6	+1.5V	PWR	+1.5V
7	PCIE_CLK_REQ#	Signal	
8	NC		
9	GND	GND	
10	NC		
11	PCIE_REF_CLK-	DIFF	
12	NC		
13	PCIE_REF_CLK+	DIFF	
14	NC		
15	GND	GND	
16	NC		
17	NC		
18	GND	GND	
19	NC		
20	W_DISABLE#	Signal	+3.3V

Pin	Pin Name	Signal Type	Signal Level
21	GND	GND	
22	PCIE_RST#	Signal	+3.3V
23	PCIE_RX-/SATA_RX+	DIFF	
24	+3.3V	PWR	+3.3V
25	PCIE_RX+/SATA_RX-	DIFF	
26	GND	GND	
27	GND	GND	
28	+1.5V	PWR	+1.5V
29	GND	GND	
30	SMB_CLK	Signal	+3.3V
31	PCIE_TX-/SATA_TX-	DIFF	
32	SMB_DATA	Signal	+3.3V
33	PCIE_TX+/SATA_TX+	DIFF	
34	GND	GND	
35	GND	GND	
36	USB_D-	DIFF	
37	GND	GND	
38	USB_D+	DIFF	
39	+3.3V	PWR	+3.3V
40	GND	GND	
41	+3.3V	PWR	+3.3V
42	NC		
43	GND	GND	
44	NC		
45	NC		
46	NC		

### 2.4.5 Dual USB 3.2 Port (CN11)

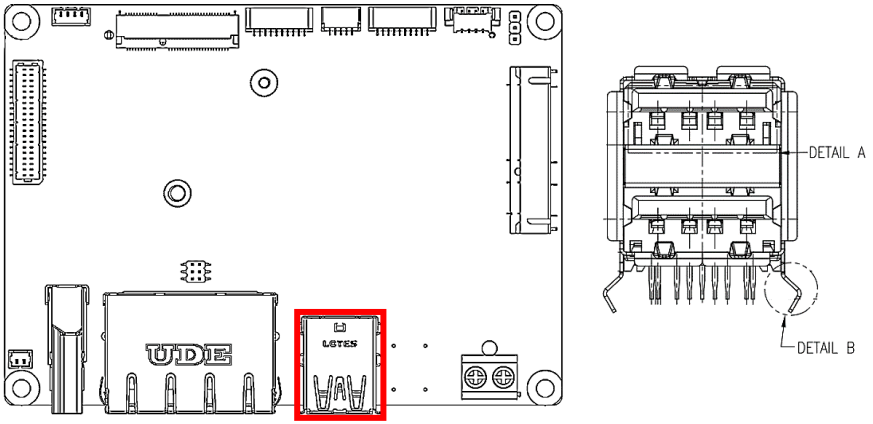

Pin	Pin Name	Signal Type	Signal Level
1	+V5A_USB12	PWR	+5V(0.9A)
2	USB2_0_DN	DIFF	
3	USB2_0_DP	DIFF	
4	GND	GND	
5	USB3_0_RXN	DIFF	
6	USB3_0_RXP	DIFF	
7	GND	GND	
8	USB3_0_TXN	DIFF	
9	USB3_0_TXP	DIFF	
10	+V5A_USB12	PWR	+5V(0.9A)
11	USB2_1_DN	DIFF	
12	USB2_1_DP	DIFF	
13	GND	GND	
14	USB3_1_RXN	DIFF	
15	USB3_1_RXP	DIFF	
16	GND	GND	
17	USB3_1_TXN	DIFF	
18	USB3_1_TXP	DIFF	

**Note:** USB 3.2 power current max: 0.9A.

### 2.4.6 SPI (For BIOS) (CN15)

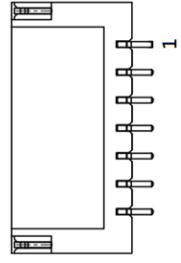
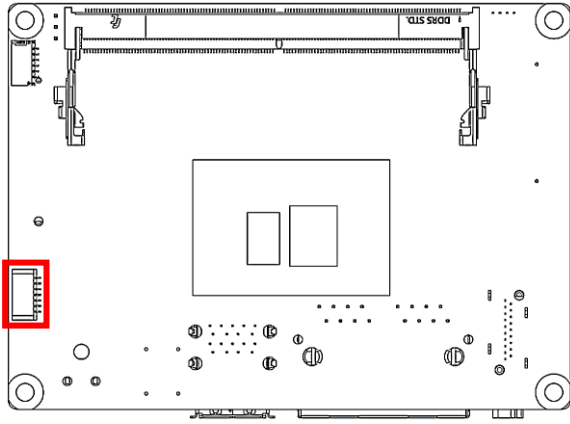

Pin	Pin Name	Signal Type	Signal Level
1	SPI_SO	Signal	
2	GND	GND	
3	SPI_CLK	Signal	
4	+V3P3A_SPI	PWR	3.3A
5	SPI_SI	Signal	
6	SPI_CS	Signal	
7	NC		

### 2.4.7 4-Pin Fan (CN16)

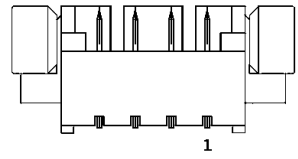
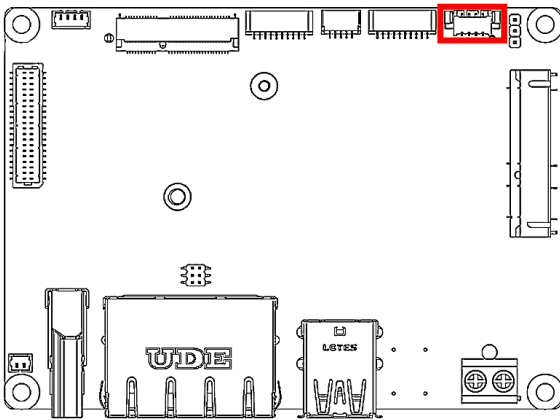

Pin	Pin Name	Signal Type	Signal Level
1	GND	GND	
2	+V12S	PWR	+12V
3	FAN_TAC	Signal	
4	FAN_CTL	Signal	

**Note:** CN16 Smart fan power current max: 1.0A.

### 2.4.8 I2C/SMBus (CN17)

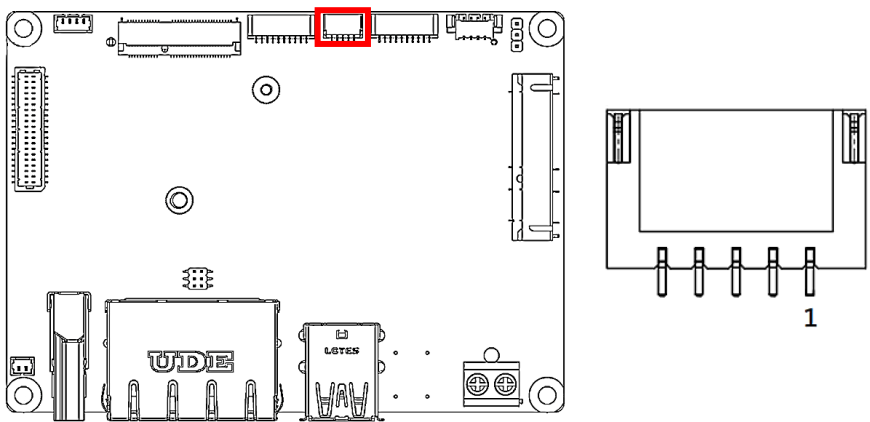

Pin	Pin Name	Signal Type	Signal Level
1	+V3P3A/+V3P3S	PWR	+3.3V
2	SMB_CLK/I2C_CLK	IN/OUT	+3.3V
3	SMB_DATA/I2C_DATA	OUT	+3.3V
4	SMBALERT#/INT _SERIRQ	IN	+3.3V
5	GND	PWR	+3.3V

## 2.4.9 eSPI Debug Connector (CN18)

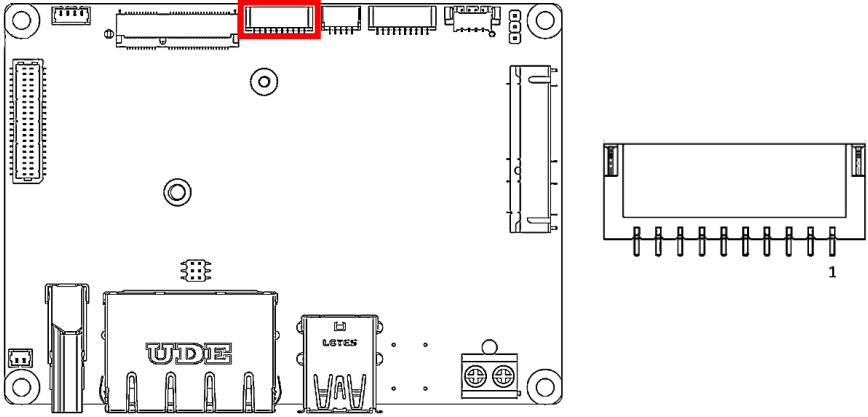

Pin	Pin Name	Signal Type	Signal Level
1	ESPI_IO0	Signal	+1.8V
2	ESPI_IO1	Signal	+1.8V
3	ESPI_IO2	Signal	+1.8V
4	ESPI_IO3	Signal	+1.8V
5	+V3.3S	PWR	+3.3V
6	ESPI_CS	Signal	
7	ESPI_RESET#	Signal	+1.8V
8	GND	GND	
9	ESPI_CLK	Signal	1.8V
10	+V3P3A	Signal	+3.3V

## 2.4.10 M.2 2230 E-Key (CN19)

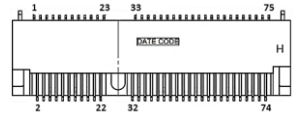
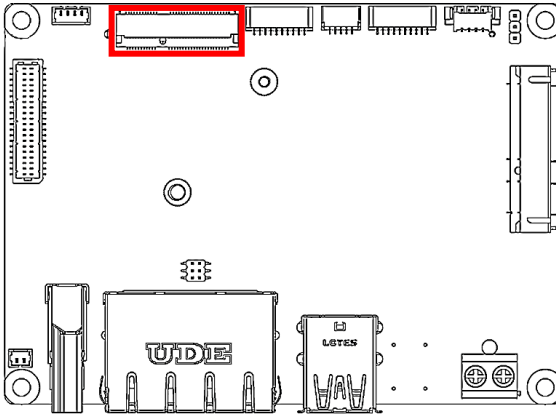

Pin	Pin Name	Signal Type	Signal Level
1	GND	GND	GND
2	+V3P3A	PWR	+3.3V
3	USB2_10_DP	DIFF	-
4	+V3P3A	PWR	+3.3V
5	USB2_10_DN	DIFF	-
6	NC	-	-
7	GND	GND	GND
8	NC	-	-
9	CNV_WR_D1_DN	DIFF	-
10	KEYE_CNV_RF_RST	IN	-
11	CNV_WR_D1_DP	DIFF	-
12	NC	-	-
13	GND	GND	GND
14	KEYE_CNV_CLKREQ	OUT	-
15	CNV_WR_D0_DN	DIFF	-
16	NC	-	-
17	CNV_WR_D0_DP	DIFF	-
18	GND	GND	GND
19	GND	GND	GND
20	KEYE_UART_WAKE_N	IN	-
21	CNV_WR_CLK_DN	DIFF	-
22	CNV_BRI_RSP	IN	-
23	CNV_WR_CLK_DP	DIFF	-
32	CNV_RGI_DT	IN	-

Pin	Pin Name	Signal Type	Signal Level
33	GND	GND	GND
34	CNV_RGI_RSP	OUT	-
35	PCIE_8_TXP	DIFF	-
36	CNV_BRI_DT	-	-
37	PCIE_8_TXN	DIFF	-
38	MLK_RST_N	IN	-
39	GND	GND	GND
40	MLK_DATA	IN/OUT	-
41	PCIE_8_RXP	DIFF	-
42	MLK_CLK	IN	-
43	PCIE_8_RXN	DIFF	-
44	NC	-	-
45	GND	GND	GND
46	NC	-	-
47	PCIE_3_CLK_DP	DIFF	-
48	NC	-	-
49	PCIE_3_CLK_DN	DIFF	-
50	SUS_CLK	IN	-
51	GND	GND	GND
52	BUF_PLT_RST#	IN	-
53	PCIE_CLKREQ#3	OUT	-
54	NC	-	-
55	PCIE_WAKE#	IN/OUT	-
56	NC	-	-
57	GND	GND	GND
58	NC	-	-
59	CNV_WT_D1_DN	DIFF	-
60	NC	-	-
61	CNV_WT_D1_DP	DIFF	-
62	NC	-	-
63	GND	GND	GND
64	NC	-	-
65	CNV_WT_D0_DN	DIFF	-
66	NC	-	-
67	CNV_WT_D0_DP	DIFF	-
68	NC	-	-
69	GND	GND	GND
70	NC	-	-
71	CNV_WT_CLK_DN	DIFF	-

Pin	Pin Name	Signal Type	Signal Level
72	+V3P3A	PWR	+3.3V
73	CNV_WT_CLK_DP	DIFF	-
74	+V3P3A	PWR	+3.3V
75	GND	GND	GND

### 2.4.11 Front Panel (CN22)

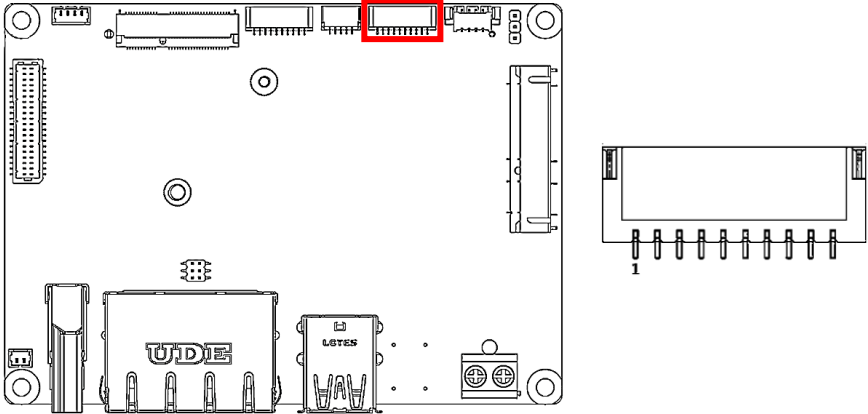

Pin	Pin Name	Signal Type	Signal Level
1	GND	GND	
2	EXT_PWRBTN#	Signal	
3	FP_IDELED#	Signal	
4	+V3P3S	PWR	+3.3V
5	FP_BUZZER	Signal	
6	+V5S	PWR	+5V
7	GND		
8	+V3P3S	PWR	+3.3V
9	GND		
10	HWRST#	Signal	

### 2.4.12 +9V - 36V Power Input (CN23)

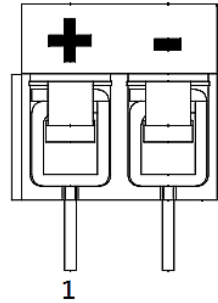
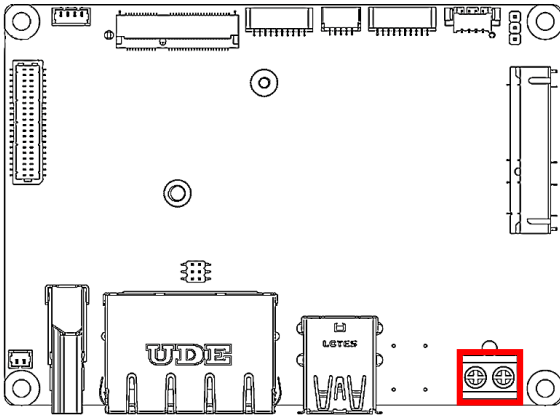

Pin	Pin Name	Signal Type	Signal Level
1	+V_IN	PWR	+12V
2	GND	GND	

### 2.4.13 Vcore Programing Connector (CN25)

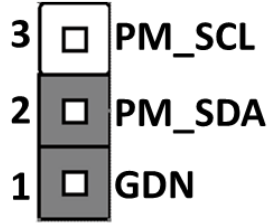
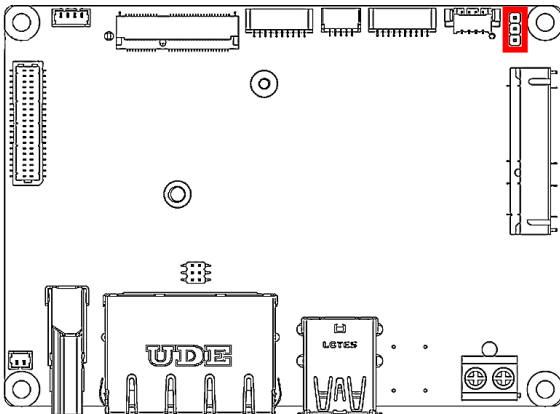

Pin	Pin Name	Signal Type	Signal Level
1	PM_SCL	IN/OUT	3.3V
2	PM_SDA	IN/OUT	3.3V
3	GND	GND	

### 2.4.14 Audio Connector (CN28)

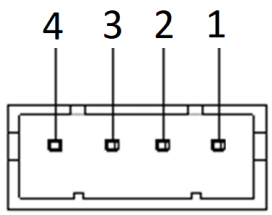
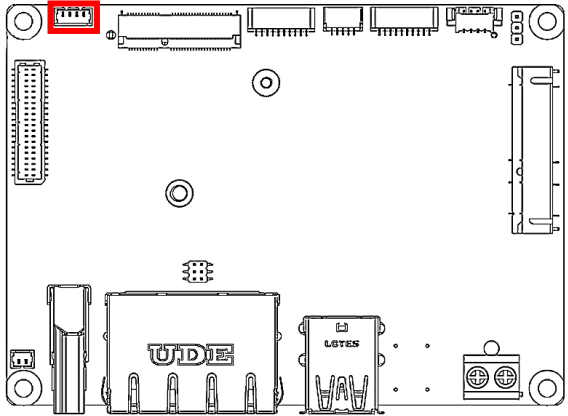

Pin	Pin Name	Signal Type	Signal Level
1	LOUT_R	Signal	
2	AUD_GND	GND	
3	LOUT_L	Signal	
4	AUD_GND	GND	

### 2.4.15 4-bit GPIO (CN31)

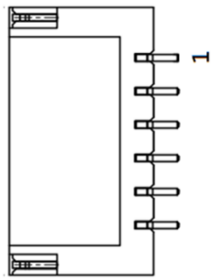
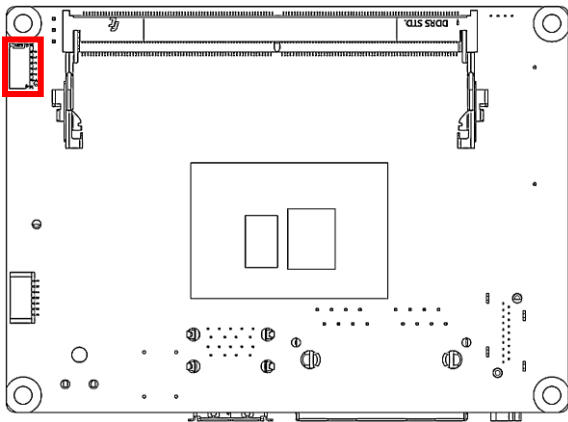

Pin	Pin Name	Signal Type	Signal Level
1	+V5S	VDD	5V
2	GPIO_0	Signal	
3	GPIO_1	Signal	

Pin	Pin Name	Signal Type	Signal Level
4	GPIO_2	Signal	
5	GPIO_3	Signal	
6	GND	GND	

**Note:** CN31 GPIO power current max: 0.5A.

### 2.4.16 COM 1 ~ 2 Connector (CN32)

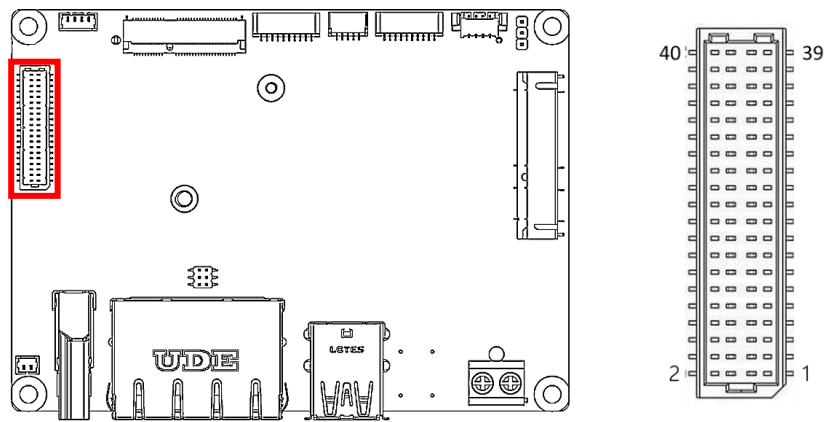

RS-232/422/485			
Pin	Pin Name	Signal Type	Signal Level
1	COM1: DCD/RS422_TX-/RS485_D-	IN / OUT	±5V
2	COM2: DCD/RS422_TX-/RS485_D-	IN / OUT	±5V
3	COM1: RX / RS422_TX+ / RS485_D+	IN / OUT	±5V
4	COM2: RX / RS422_TX+ / RS485_D+	IN / OUT	±5V
5	COM1: TX / RS422_RX+	OUT / IN	±5V
6	COM2: TX / RS422_RX+	OUT / IN	±5V
7	COM1: DTR / RS422_RX-	OUT / IN	±5V
8	COM2: DTR / RS422_RX-	OUT / IN	±5V
9	COM1: GND	GND	
10	COM2: GND	GND	
11	COM1: DSR	IN	
12	COM2: DSR	IN	

RS-232/422/485			
Pin	Pin Name	Signal Type	Signal Level
13	COM1: RTS	OUT	±5V
14	COM2: RTS	OUT	±5V
15	COM1: CTS	IN	
16	COM2: CTS	IN	
17	COM1: RI	IN/ PWR	+5V/+12V
18	COM2: RI/+5V/+12V	IN/ PWR	+5V/+12V
19	N.C	N.C	
20	N.C	N.C	
21	COM3: DCD / RS422_TX-/ RS485_D-	IN / OUT	±5V
22	COM4: DCD/ RS422_TX-/ RS485_D-	IN / OUT	±5V
23	COM3: RX / RS422_TX+ / RS485_D+	IN / OUT	±5V
24	COM4: RX / RS422_TX+ / RS485_D+	IN / OUT	±5V
25	COM3: TX / RS422_RX+	OUT / IN	±5V
26	COM4: TX / RS422_RX+	OUT / IN	±5V
27	COM3: DTR / RS422_RX-	OUT / IN	±5V
28	COM4: DTR / RS422_RX-	OUT / IN	±5V
29	COM3: GND	GND	
30	COM4: GND	GND	
31	COM3: DSR	IN	
32	COM4: DSR	IN	
33	COM3: RTS	OUT	±5V
34	COM4: RTS	OUT	±5V
35	COM3: CTS	IN	
36	COM4: CTS	IN	
37	COM3: RI/+5V/+12V	IN/ PWR	+5V/+12V
38	COM4: RI	IN/ PWR	+5V/+12V
39	N.C	N.C	
40	N.C	N.C	

### 2.4.17 DDR5 SODIMM (DIMM1)

Reverse specification.

## 2.5 Hardware Installation

### 2.5.1 Wall Mount Kit

Applicable Model: PICO-ADN4-SEMI

Part Number: PICO-SEMI-WMT1

- Use the supplied screws to attach each bracket to the threaded holes on the enclosure.
- Tighten the screws securely using a Phillips screwdriver, but do not overtighten.

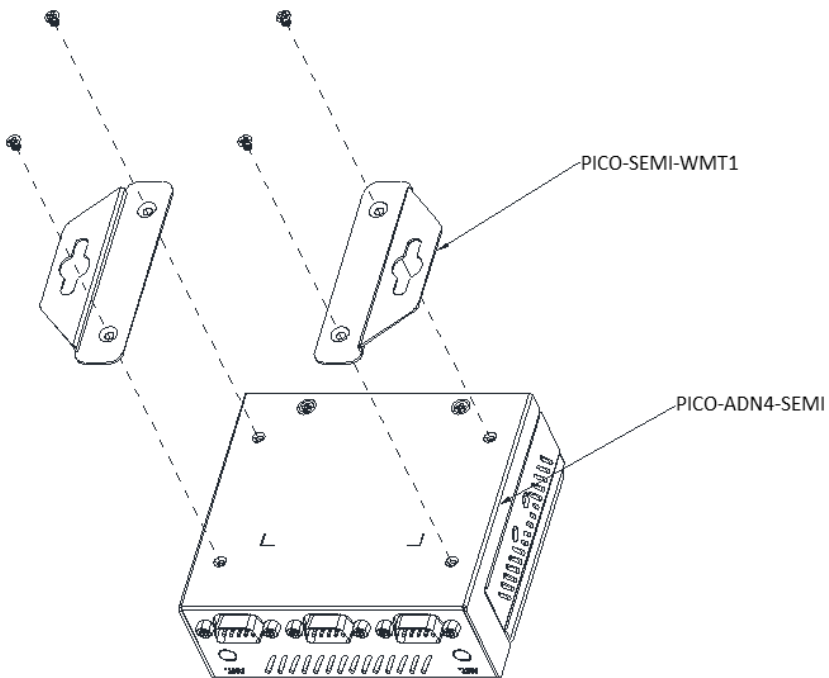

## 2.5.2 DIN Rail Kit

**Applicable Model:** PICO-ADN4-SEMI

**Part Number:** PICO-SEMI-DIN01

- Use the supplied screws to attach the rail bracket to the threaded holes on the enclosure.
- Tighten the screws securely using a Phillips screwdriver, but do not overtighten.

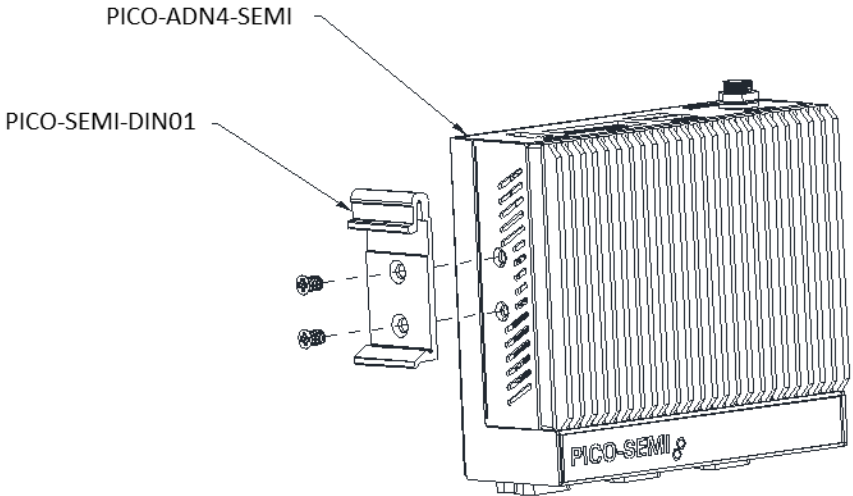

# Chapter 3

---

AMI BIOS Setup

## 3.1 System Test and Initialization

---

These routines test and initialize board hardware. If the routines encounter an error during the tests, you will either hear a few short beeps or see an error message on the screen. There are two kinds of errors: fatal and non-fatal. The system can usually continue the boot up sequence with non-fatal errors.

### System configuration verification

These routines check the current system configuration stored in the CMOS memory and BIOS NVRAM. If system configuration is not found or a system configuration data error is detected, the system will load optimized default and re-boot with this default system configuration automatically.

There are four situations in which you will need to setup system configuration:

1. You are starting your system for the first time
2. You have changed the hardware attached to your system
3. The system configuration is reset by Clear-CMOS jumper
4. The CMOS memory has lost power and the configuration information has been erased.

The PICO-ADN4-SEMI CMOS memory has an integral lithium battery backup for data retention. However, you will need to replace the battery unit when it finally runs down.

## 3.2 AMI BIOS Setup

---

AMI BIOS ROM has a built-in Setup program that allows users to modify the basic system configuration. This type of information is stored in battery-backed CMOS RAM and BIOS NVRAM so that it retains the Setup information when the power is turned off.

### Entering Setup

Power on the computer and press <Del> or <ESC> immediately. This will allow you to enter Setup.

### Main

Set the date, use tab to switch between date elements.

### Advanced

Enable/disable the feature configurations.

### Chipset

Host bridge parameters.

### Boot

Enables/disable quiet boot option.

### Security

Set setup administrator password.

### Save & Exit

Exit system setup after saving the changes.

### 3.3 Setup Submenu: Main

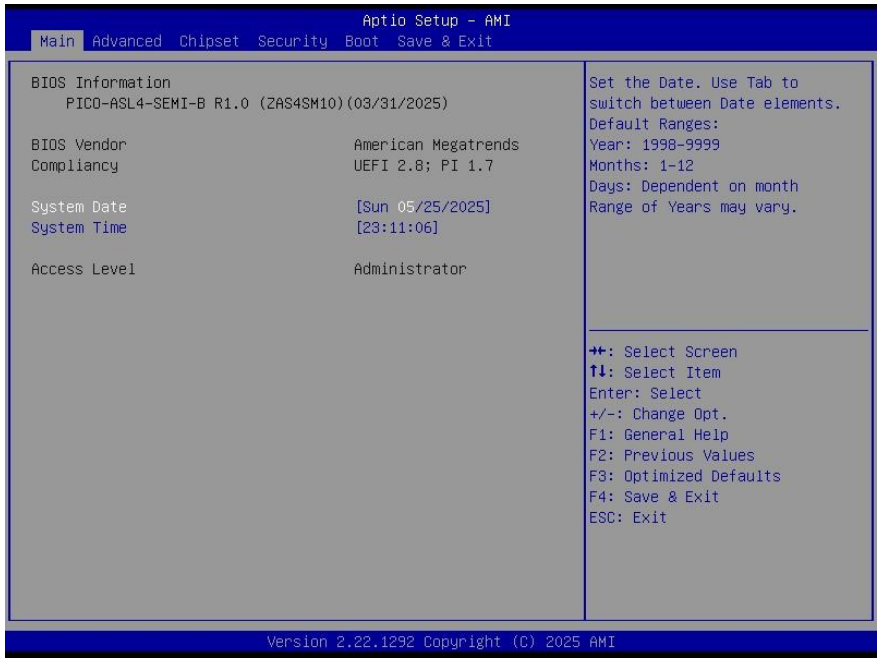

### 3.4 Setup Submenu: Advanced

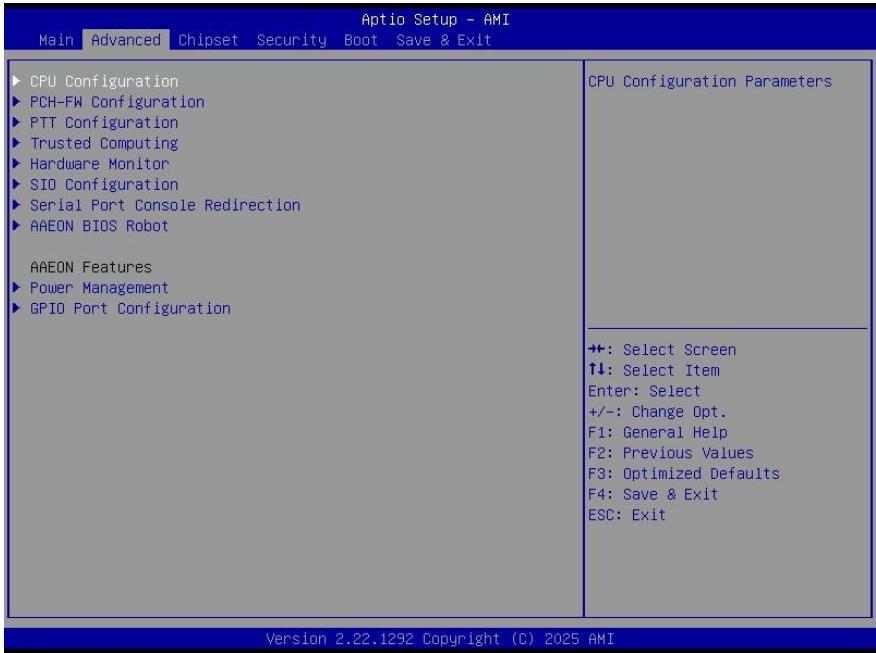

### 3.4.1 CPU Configuration



Options Summary		
Intel (VMX) Virtualization Technology	Disabled	
	Enabled	Optimal Default, Failsafe Default
When enabled, a VMM can utilize the additional hardware capabilities provided by Vanderpool Technology.		
Intel® SpeedStep™	Disabled	
	Enabled	Optimal Default, Failsafe Default
Allows more than two frequency ranges to be supported.		
Turbo Mode	Disabled	
	Enabled	Optimal Default, Failsafe Default
Enable or disable processor Turbo Mode (requires EMTTM to be enabled). Auto = enabled.		
C states	Disabled	
	Enabled	Optimal Default, Failsafe Default
Enable/Disable CPU Power Management. Allows CPU to go to C states when it's not 100% utilized.		

### 3.4.2 PCH-FW Configuration

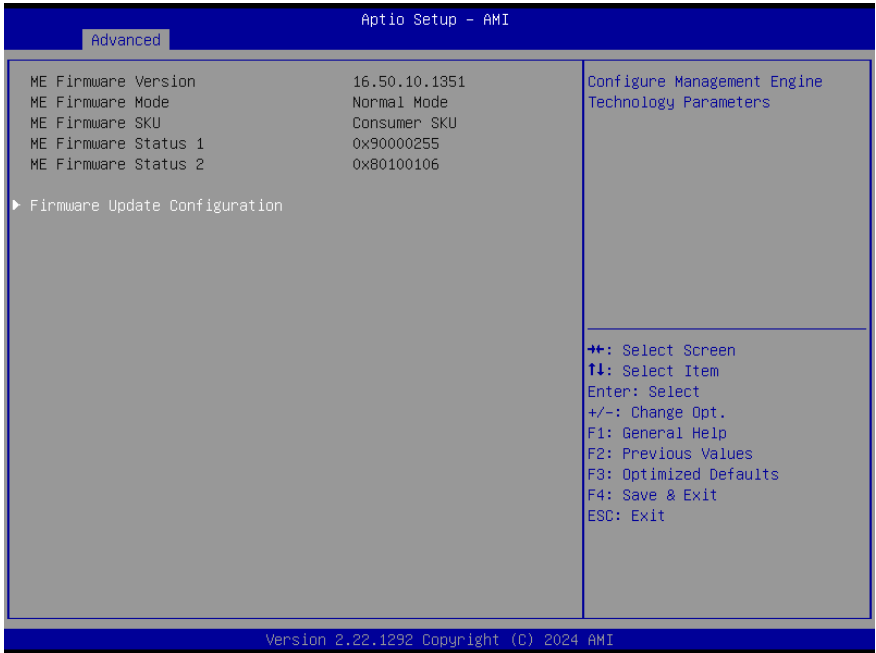

### 3.4.2.1 Firmware Update Configuration

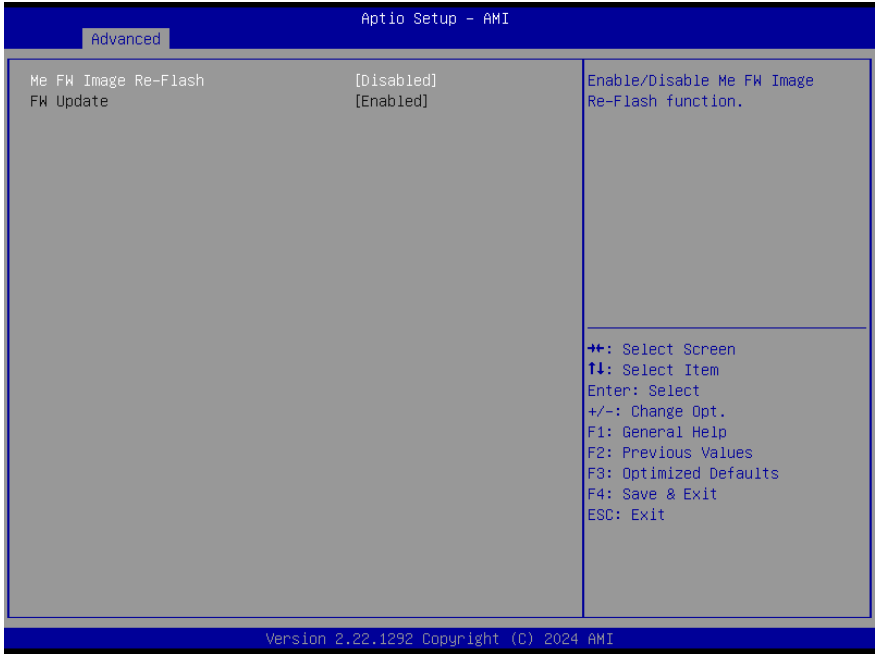

Options Summary		
Me FW Image Re-Flash	Enabled	
	Disabled	Optimal Default, Failsafe Default
Enable or disable the Management Engine firmware image re-flash function.		
FW Update	Disabled	
	Enabled	Optimal Default, Failsafe Default
Enable or disable the Management Engine firmware update function.		

### 3.4.3 PTT Configuration

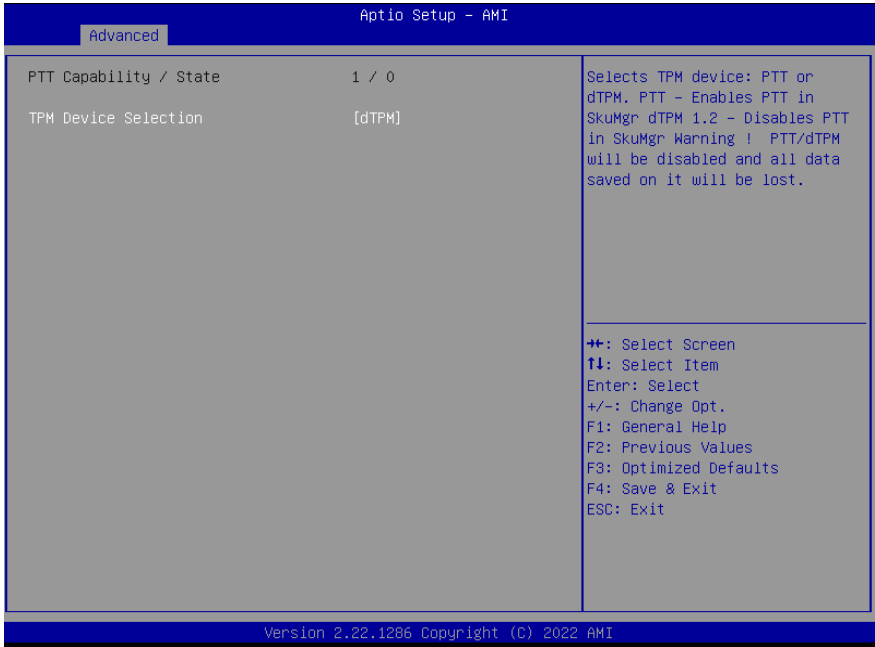

Options Summary		
TPM Device Selection	dTPM	Optimal Default, Failsafe Default
	PTT	
<p>TPM Device Selection: Choose between PTT or discrete TPM.                      PTT – Enables PTT in SkuMgr.                      dTPM – Disables PTT in SkuMgr.  <b>Warning:</b> Selecting PTT or dTPM will disable the other, and all data stored on it will be lost.</p>		

### 3.4.4 Trusted Computing



Options Summary		
Security Device Support	Enable	Optimal Default, Failsafe Default
	Disable	
Security Device Support: Enable or disable BIOS support for the security device. When disabled, the OS will not detect the device, and the TCG EFI protocol and INT 1Ah interface will be unavailable.		
SHA256 PCR Bank	Enabled	Optimal Default, Failsafe Default
	Disabled	
Enable or Disable SHA256 PCR Bank.		
SHA384 PCR Bank	Enabled	Optimal Default, Failsafe Default
	Disabled	
Enable or Disable SHA384 PCR Bank.		
Pending operation	None	Optimal Default, Failsafe Default
	TPM Clear	
Schedule an Operation for the Security Device. <b>Note:</b> Your Computer will reboot during restart in order to change State of Security Device.		
Platform Hierarchy	Enabled	Optimal Default, Failsafe Default
	Disabled	
Enable or Disable Platform Hierarchy		

Options Summary		
Storage Hierarchy	Enabled	Optimal Default, Failsafe Default
	Disabled	
Enable or Disable Storage Hierarchy		
Endorsement Hierarchy	Enabled	Optimal Default, Failsafe Default
	Disabled	
Enable or Disable Endorsement Hierarchy		
Physical Presence Spec Version	1.3	Optimal Default, Failsafe Default
	1.2	
Select whether to report PPI Spec Version 1.2 or 1.3 to the OS. Note: Some HCK tests may not support Version 1.3.		
Device Select	Auto	
	TPM 1.2	
	TPM 2.0	Optimal Default, Failsafe Default
TPM Version Support: TPM 1.2 – Restricts support to TPM 1.2 devices. TPM 2.0 – Restricts support to TPM 2.0 devices. Auto – Supports both versions, defaulting to TPM 2.0 if no device is found. TPM 1.2 devices will still be enumerated.		

### 3.4.5 Hardware Monitor

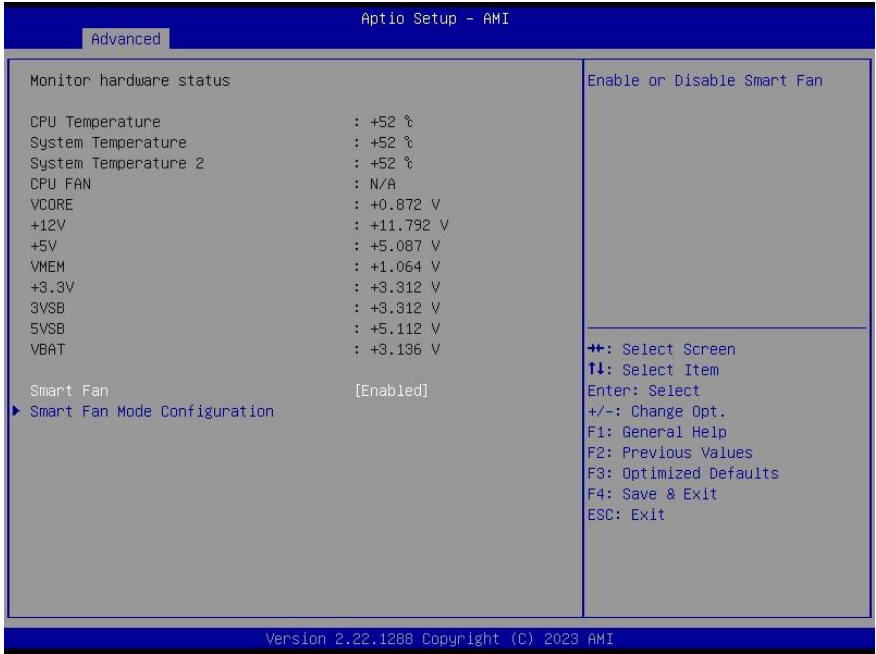

Options Summary		
Smart Fan	Disabled	
	Enabled	Optimal Default, Failsafe Default
Enables or Disables Smart Fan.		

### 3.4.5.1 Smart Fan Mode Configuration



Options Summary		
Fan 1 Smart Fan Control	Manual Duty Mode	
	Auto Duty-Cycle Mode	Optimal Default, Failsafe Default
Smart Fan Mode Select		
Temperature Source	CPU Temperature	Optimal Default, Failsafe Default
	System Temperature	
	System Temperature 2	
Select the monitored temperature source for this fan.		
Temperature 1	86	
Duty Cycle 1	100	
Automatic Fan Speed Control: Fan speed adjusts according to temperature using a duty cycle range of 1-100.		

### 3.4.6 SIO Configuration



### 3.4.6.1 Serial Port 1 Configuration

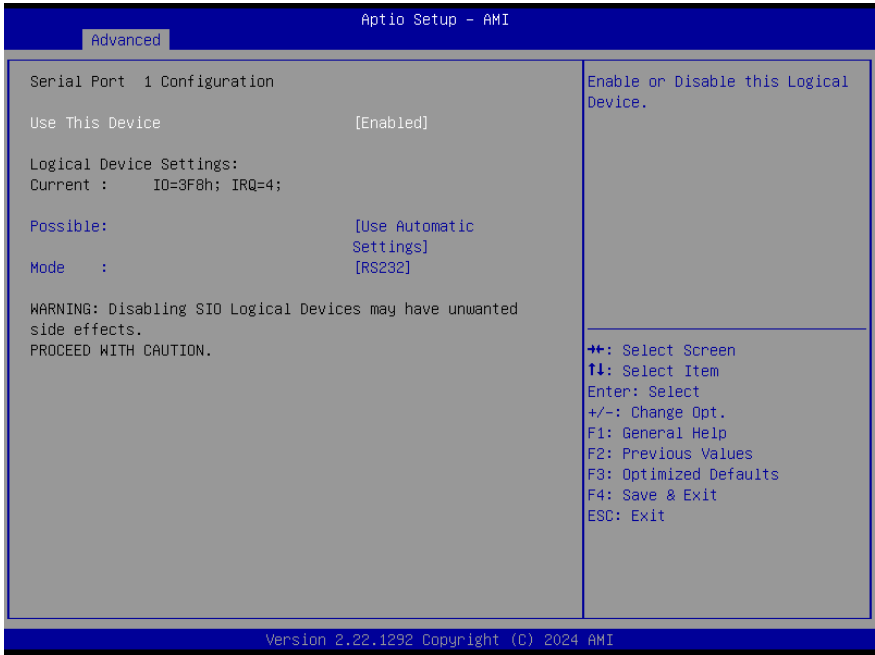

Options Summary		
Use This Device	Disable	
	Enable	Optimal Default, Failsafe Default
Enable or Disable this Logical Device.		
Possible:	Use Automatic Settings	Optimal Default, Failsafe Default
	IO=3F8h; IRQ=4	
	IO=2F8h; IRQ=3	
Allows the user to modify the device's resource settings. New settings take effect on this setup page after the system restarts.		
Mode:	RS232	Optimal Default, Failsafe Default
	RS422	
	RS485	
UART RS232, 422, 485 selection.		

### 3.4.6.2 Serial Port 2 Configuration

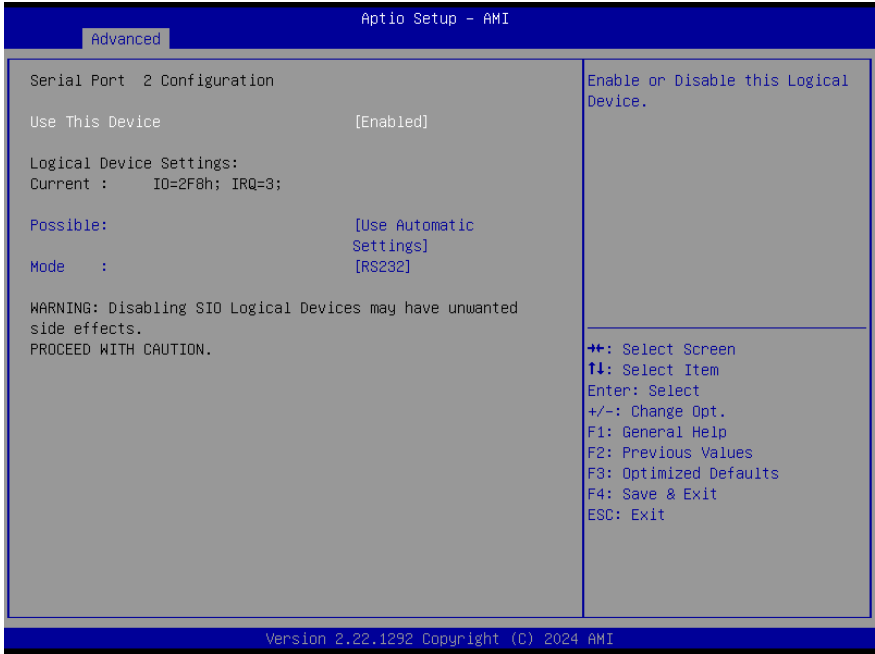

Options Summary		
Use This Device	Disable	
	Enable	Optimal Default, Failsafe Default
Enable or Disable this Logical Device.		
Possible:	Use Automatic Settings	Optimal Default, Failsafe Default
	IO=2F8h; IRQ=3	
	IO=3F8h; IRQ=4	
Allows the user to modify the device's resource settings. New settings take effect on this setup page after the system restarts.		
Mode:	RS232	Optimal Default, Failsafe Default
	RS422	
	RS485	
UART RS232, 422, 485 selection.		

### 3.4.7 Serial Port Console Redirection

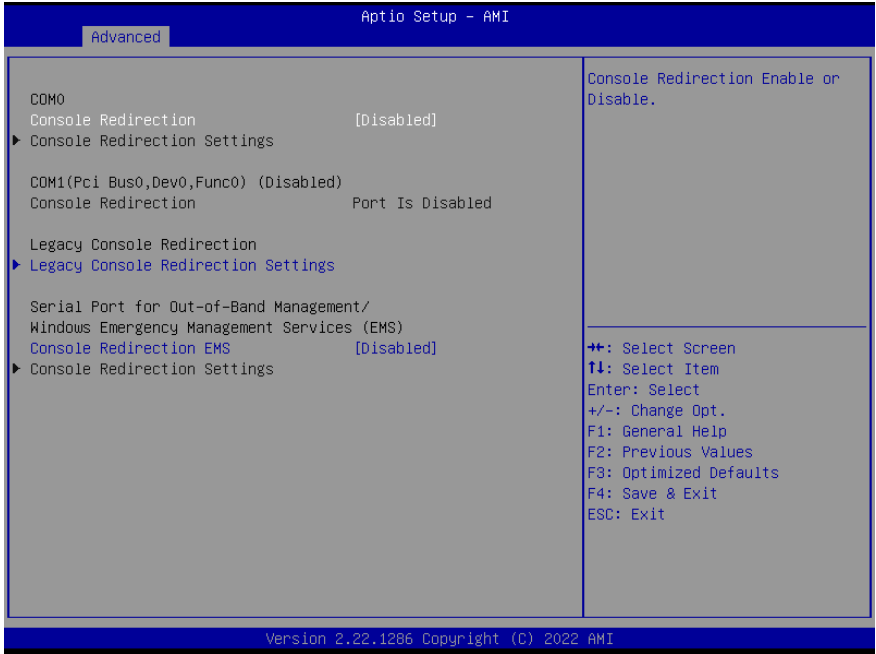

Options Summary		
Console Redirection	Disabled	Optimal Default, Failsafe Default
	Enabled	
Enable or disable console redirection.		
Console Redirection EMS	Disabled	Optimal Default, Failsafe Default
	Enabled	
Enable or disable console redirection.		

### 3.4.7.1 Legacy Console Redirection Settings



Options Summary		
Redirection COM port	COM0	Optimal Default, Failsafe Default
	COM1(Pci Bus0, Dev0, Func0) (Disabled)	
Choose the COM port for displaying redirection of Legacy OS and Legacy OPROM messages.		
Resolution	80x24	Optimal Default, Failsafe Default
	80x25	
Specifies the number of rows and columns supported for console redirection on legacy OS		
Redirect After POST	Always Enable	Optimal Default, Failsafe Default
	BootLoader	
Bootloader – Legacy Console Redirection is disabled before booting to a legacy OS. Always Enable – Legacy Console Redirection is enabled for legacy OS. This is the default setting.		

### 3.4.8 AAEON BIOS Robot

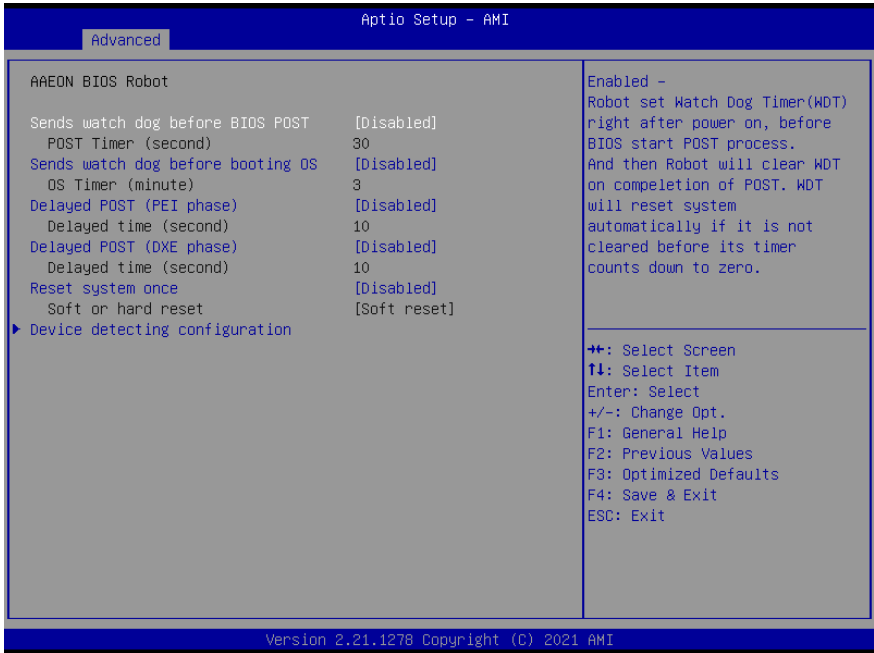

Options Summary		
Sends watch dog before BIOS POST	Disabled	Optimal Default, Failsafe Default
	Enabled	
Enabled: Robot sets the Watch Dog Timer (WDT) immediately after power-on, before the BIOS starts the POST process, and clears it upon POST completion. If the WDT is not cleared before the timer expires, it will automatically reset the system.		
POST Timer (second)	30	Optimal Default, Failsafe Default
POST Watch Dog Timer: Sets the timer count for POST. <b>Warning:</b> Do not set a value equal to or shorter than the normal POST duration, or the system may fail to complete POST unless BIOS settings are cleared. A value greater than 2x the normal POST time is recommended.		
Sends watch dog before booting OS	Disabled	Optimal Default, Failsafe Default
	Enabled	
Enabled: Robot sets the Watch Dog Timer (WDT) after POST completion, before the BIOS transfers control to the OS. <b>Warning:</b> Before enabling this function, an OS program must be responsible for clearing the WDT. This function should be disabled if the OS is performing an update.		
OS Timer (minute)	3	Optimal Default, Failsafe Default
Sets the timer count for OS loading.		

Options Summary		
Delayed POST (PEI phase)	Disabled	Optimal Default, Failsafe Default
	Enabled	
Enabled: Robot holds the BIOS from starting POST immediately after power-on, allowing POST to begin with stable power or after the system has physically warmed up. <b>Note:</b> This occurs before sending the Watch Dog Timer (WDT) signal.		
Delayed time (second)	10	Optimal Default, Failsafe Default
Period of time for Robot to hold BIOS from POST.		
Delayed POST (DXE phase)	Disabled	Optimal Default, Failsafe Default
	Enabled	
Enabled: Robot holds the BIOS before POST completion, allowing POST to start with stable power or after the system has physically warmed up. <b>Note:</b> This occurs after sending the Watch Dog Timer (WDT) signal before POST.		
Delayed time (second)	10	Optimal Default, Failsafe Default
Period of time for Robot to hold BIOS from POST.		
Reset system once	Disabled	Optimal Default, Failsafe Default
	Enabled	
Enabled: Robot performs a one-time system reset on each boot, sending a soft or hard reset to onboard devices to place them in a more stable state.		
Soft or hard reset	Soft reset	Optimal Default, Failsafe Default
	Hard reset	
Select reset type robot should send on each boot.		

### 3.4.8.1 Device Detecting Configuration

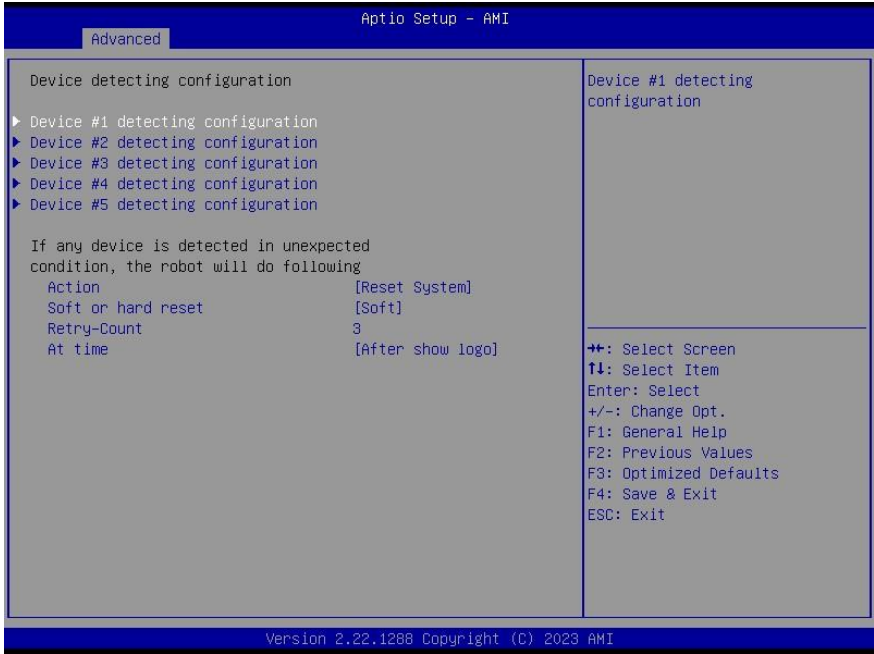

Options Summary		
Action	Reset System	Optimal Default, Failsafe Default
	Hold System	
Select action that robot should do.		
Soft or hard reset	Soft	Optimal Default, Failsafe Default
	Hard	
Select reset type robot should send on each boot.		
Retry-Count	30	Optimal Default, Failsafe Default
Retry Counter: Specifies the maximum number of system resets the Robot will perform. After reaching this count, the system continues POST.		
At time	After show logo	Optimal Default, Failsafe Default
	Before show logo	
Robot Action Time: After Show Logo – Robot performs the action after the logo is displayed, when system devices are mostly ready. Before Show Logo – Robot performs the action before the logo is displayed; some devices may not be ready.		

### 3.4.8.1.1 Device #1 Detecting Configuration

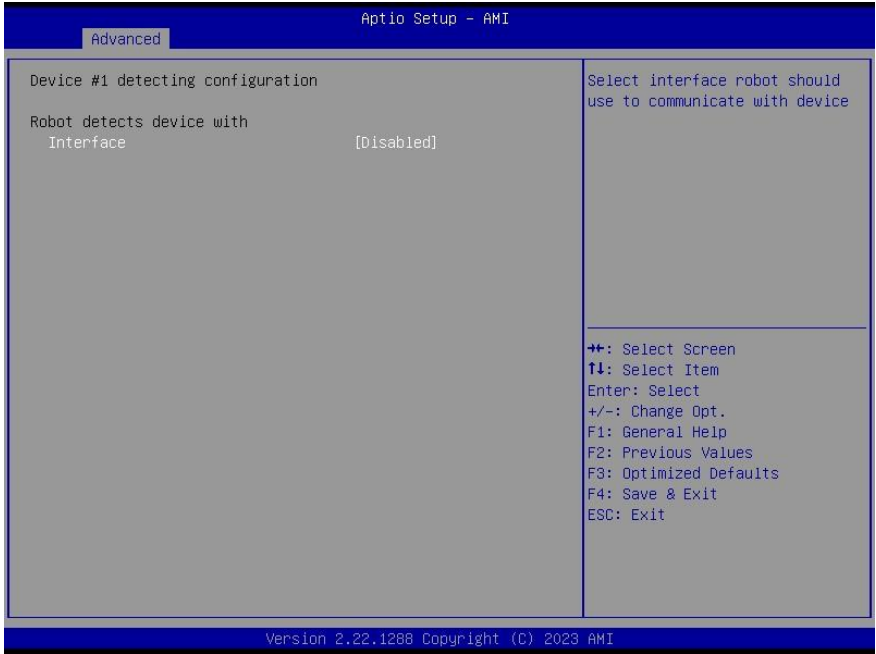

Options Summary		
Interface	Disabled	Optimal Default, Failsafe Default
	PCI	
	DIO	
	SMBUS	
	Legacy I/O	
	Super I/O	
	MMIO	
Select interface robot should use to communicate with device.		

### 3.4.8.1.2 Device #2 Detecting Configuration

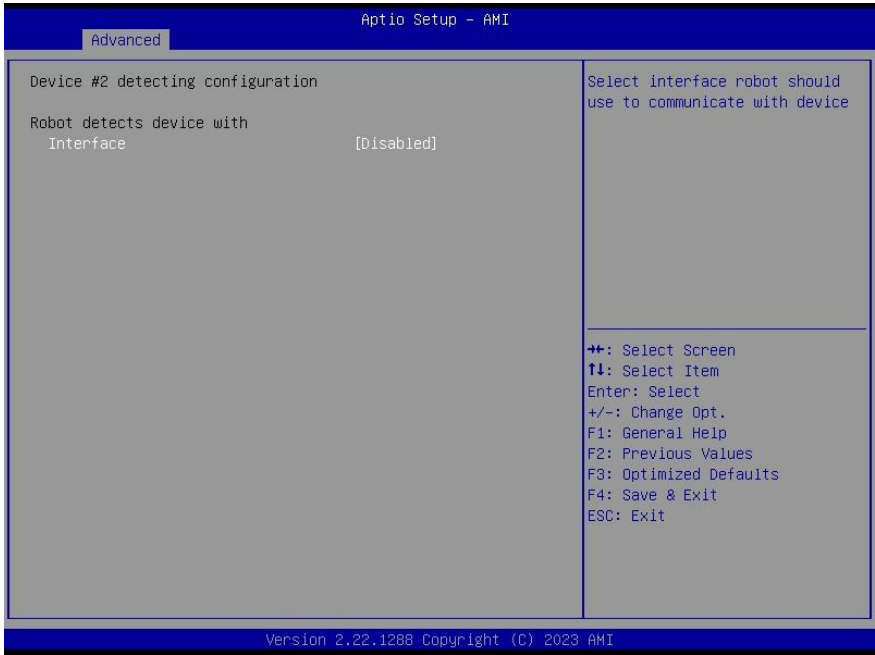

Options Summary		
Interface	Disabled	Optimal Default, Failsafe Default
	PCI	
	DIO	
	SMBUS	
	Legacy I/O	
	Super I/O	
	MMIO	
Select interface robot should use to communicate with device.		

### 3.4.8.1.3 Device #3 Detecting Configuration

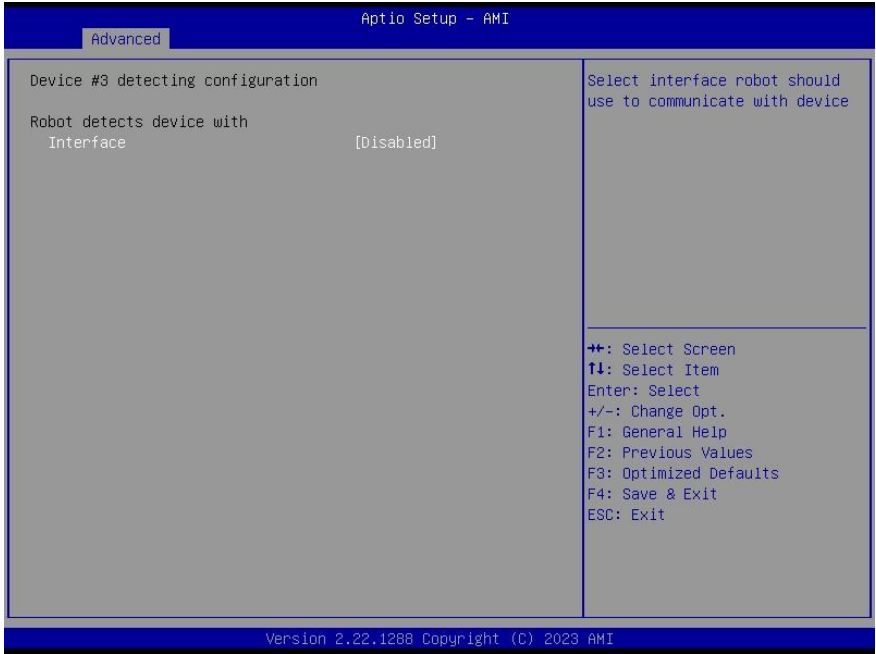

Options Summary		
Interface	Disabled	Optimal Default, Failsafe Default
	PCI	
	DIO	
	SMBUS	
	Legacy I/O	
	Super I/O	
	MMIO	
Select interface robot should use to communicate with device.		

### 3.4.8.1.4 Device #4 Detecting Configuration



Options Summary		
Interface	Disabled	Optimal Default, Failsafe Default
	PCI	
	DIO	
	SMBUS	
	Legacy I/O	
	Super I/O	
	MMIO	
Select interface robot should use to communicate with device.		

### 3.4.8.1.5 Device #5 Detecting Configuration



Options Summary		
Interface	Disabled	Optimal Default, Failsafe Default
	PCI	
	DIO	
	SMBUS	
	Legacy I/O	
	Super I/O	
	MMIO	
Select interface robot should use to communicate with device.		

### 3.4.9 Power Management

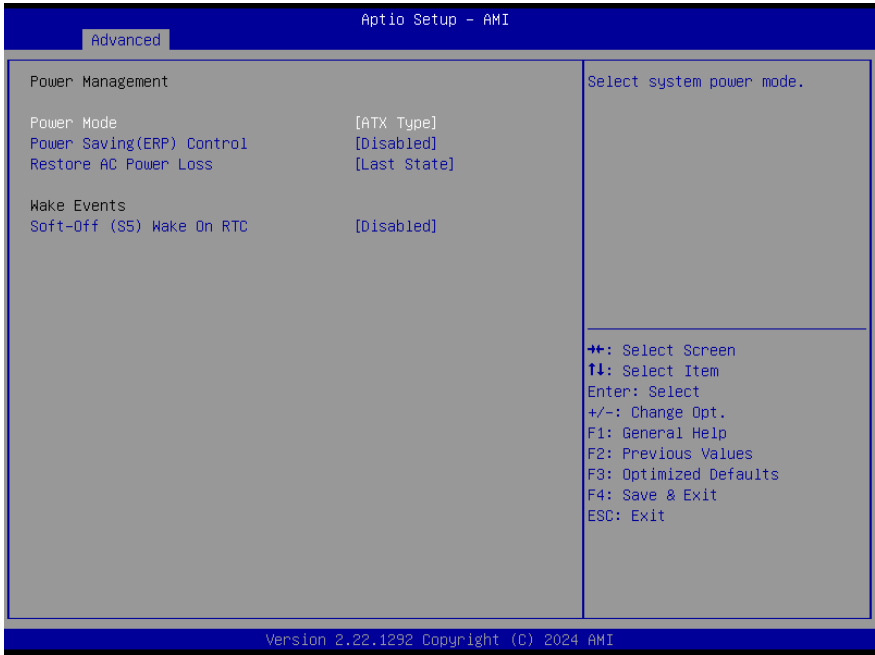

Options Summary		
Power Mode	ATX Type	Optimal Default, Failsafe Default
	AT Type	
Select power supply mode.		
Power Saving(ERP) Control	Disabled	Optimal Default, Failsafe Default
	Enabled	
Select Power saving control.		
Restore AC Power Loss	Last State	Optimal Default, Failsafe Default
	Always On	
	Always Off	
Select the power state the system will enter when power is restored after power failure.		
Soft-Off (S5) Wake On RTC	Disabled	Optimal Default, Failsafe Default
	By Date	
	By Weekday	
	Bypass	
By Date – System wakes at the specified hh:mm:ss on the selected date. By Weekday – System wakes at the specified hh:mm:ss on the enabled weekdays. Bypass – BIOS does not control the RTC wake function.		

### 3.4.10 GPIO Port Configuration



Options Summary		
GPIO Port*	Output	
	Input	
Set GPIO as Input or Output.		
Output Level	High	
	Low	
Set output level when GPIO pin is output.		

### 3.5 Setup Submenu: Chipset



### 3.5.1 System Agent (SA) Configuration



Options Summary		
VT-d	Disabled	Optimal Default, Failsafe Default
	Enabled	
VT-d capability.		

### 3.5.1.1 Memory Configuration

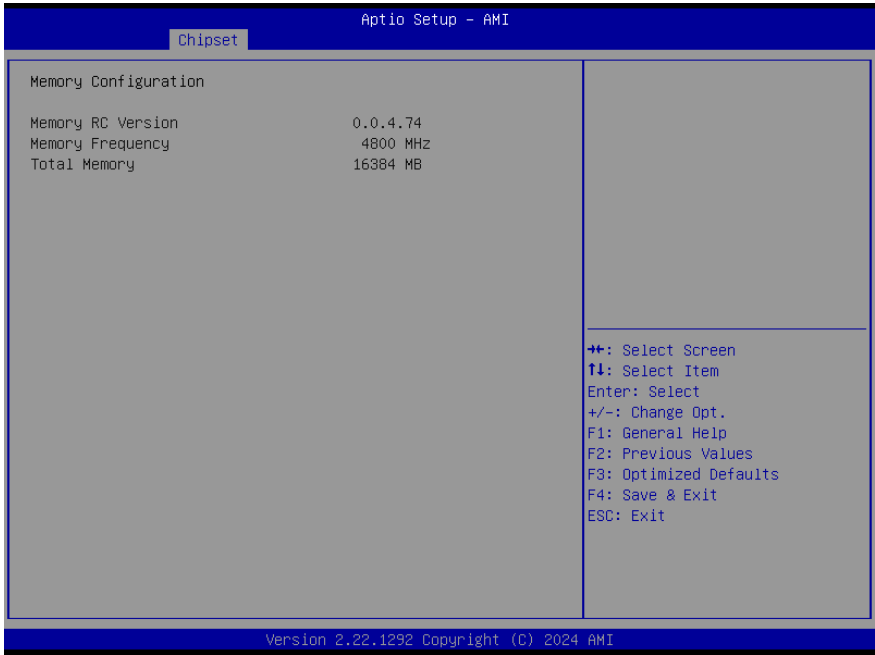

### 3.5.2 PCH-IO Configuration



Options Summary		
HD Audio	Disabled	
	Enabled	Optimal Default, Failsafe Default
Control Detection of the HD-Audio device. Disable = HAD will be unconditionally disabled. Enable = HAD will be unconditionally enabled.		
Full-MiniCard Slot Function (CN9)	SATA	Optimal Default, Failsafe Default
	PCIe	
Select function enabled for Full-MiniCard (CN9) slot.		

## 3.6 Setup Submenu: Security

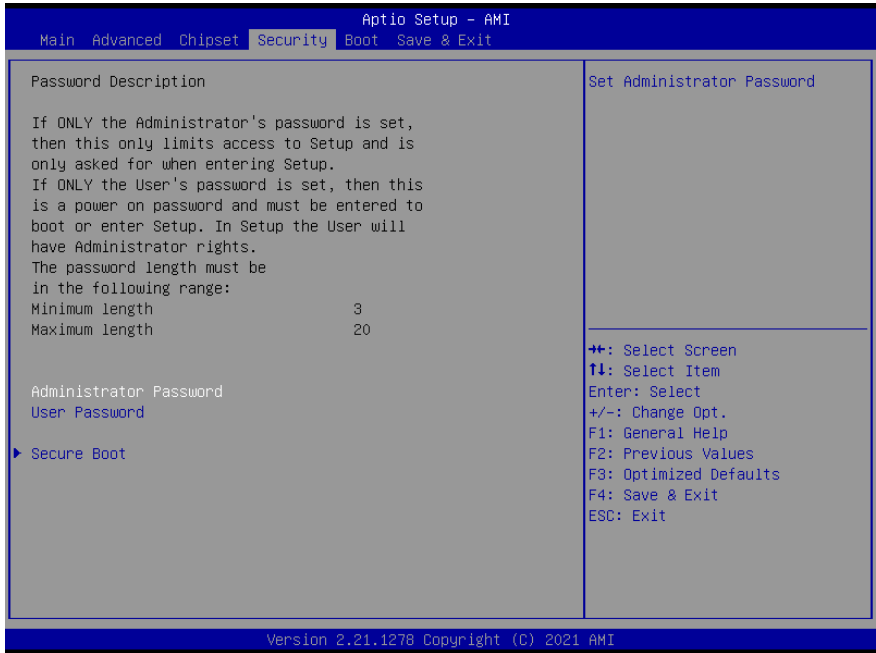

### Change User/Supervisor Password

You can install a Supervisor password, and if you install a supervisor password, you can then install a user password. A user password does not provide access to many of the features in the Setup utility.

If you highlight these items and press Enter, a dialog box appears which lets you enter a password. You can enter no more than six letters or numbers. Press Enter after you have typed in the password. A second dialog box asks you to retype the password for confirmation. Press Enter after you have retyped it correctly. The password is required at boot time, or when the user enters the Setup utility.

### Removing the Password

Highlight this item and type in the current password. At the next dialog box press Enter to disable password protection.

### 3.6.1 Secure Boot



Options Summary		
Secure Boot	Disabled	Optimal Default, Failsafe Default
	Enabled	
Secure Boot: Active when Secure Boot is enabled, the Platform Key (PK) is enrolled, and the system is in User mode. Changing the mode requires a platform reset.		
Secure Boot Mode	Custom	Optimal Default, Failsafe Default
	Standard	
Secure Boot Mode: Options are Standard or Custom. In Custom mode, a physically present user can configure Secure Boot Policy variables without full authentication.		
<b>Restore Factory Keys</b>		
Force System to User Mode. Install factory default Secure Boot key databases.		
<b>Reset to Setup Mode</b>		
Delete all Secure Boot key databases from NVRAM.		



Options Summary	
A Device Guard–ready system must not list the “Microsoft UEFI CA” certificate in the Authorized Signature Database (db).	
<b>Restore DB defaults</b>	
Restore DB variable to factory defaults.	
Platform Key (PK)	Update
Key Exchange Keys	Update
	Append
Authorized Signatures	Update
	Append
Forbidden Signatures	Update
	Append
Authorized TimeStamps	Update
	Append
OsRecovery Signatures	Update
	Append
Enroll Factory Defaults or load certificates from a file: 1.Public Key Certificate: a) EFI_SIGNATURE_LIST b) EFI_CERT_X509 (DER) c) EFI_CERT_RSA2048 (bin) d) EFI_CERT_SHAXXX 2. Authenticated UEFI Variable 3. EFI PE/COFF Image (SHA256) Key Source: Factory, External, Mixed	

### 3.7 Setup Submenu: Boot

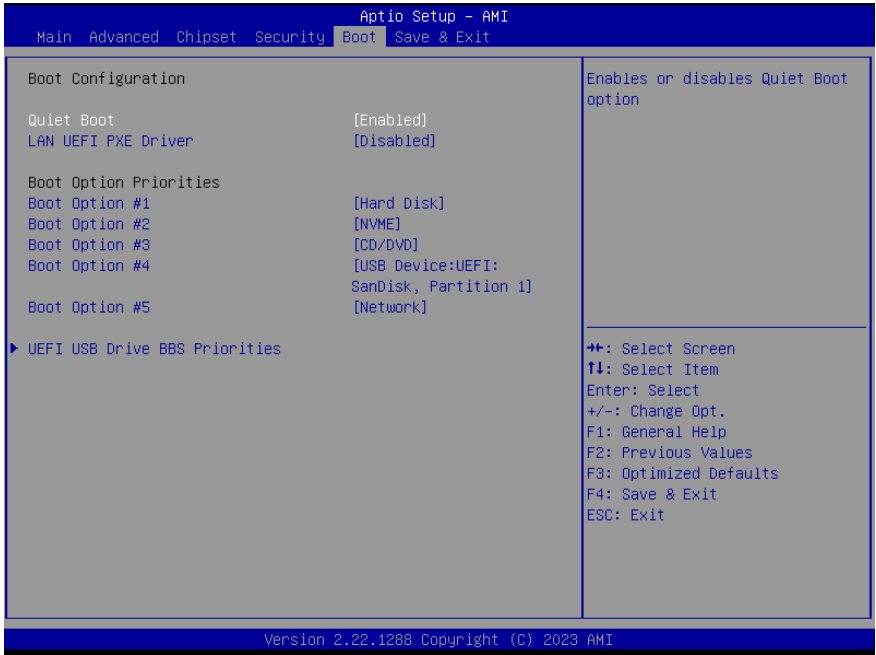

Options Summary		
Quiet Boot	Disabled	
	Enabled	Optimal Default, Failsafe Default
Enable or Disable Quiet Boot option.		
UEFI PXE Support	Disabled	Optimal Default, Failsafe Default
	Enabled	
Enable/Disable UEFI Network Stack.		
FIXED BOOT ORDER Priorities		
Sets the system boot order.		

### 3.7.1 BBS Priorities



### 3.8 Setup Submenu: Save & Exit

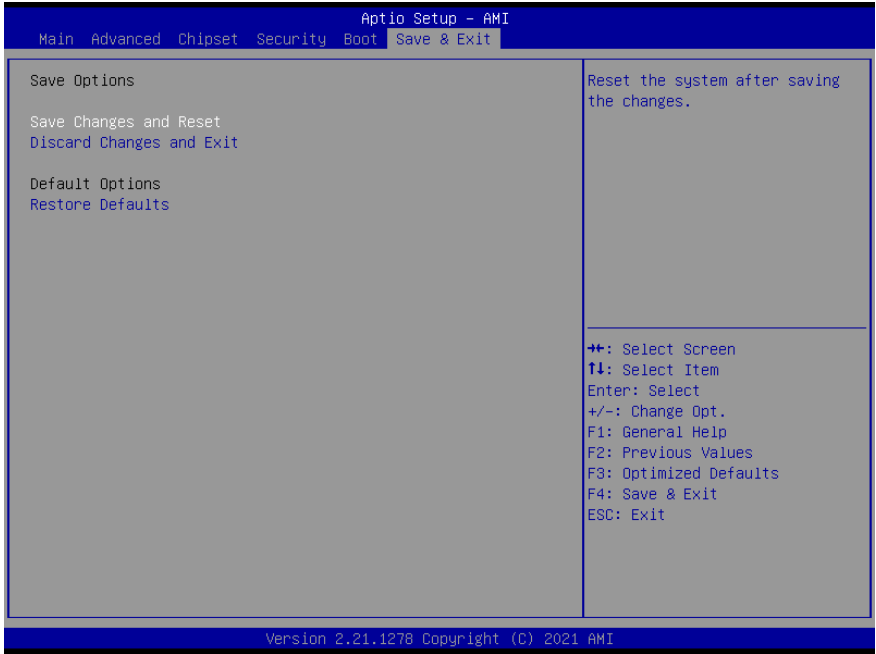

Options Summary	
Save Changes and Reset	Reset the system after saving the changes.
Discard Changes and Exit	Exit system setup without saving any changes.
Restore Defaults	Restore/Load Default values for all the setup options.

# Chapter 4

---

Drivers Installation

## 4.1 Drivers Download and Installation

---

Drivers for the PICO-ADN4-SEMI can be downloaded from the product page on the AAEON website by following this link:

<https://www.aaeon.com/>

Download the driver(s) you need and follow the steps below to install them.

### Install Chipset Driver

1. Open the **Intel Chipset** folder.
2. Run the **SetupChipset.exe** file.
3. Follow the instructions
4. Drivers will be installed automatically

### Install Graphics Driver

1. Open the **Intel Graphics** folder.
2. Run the **Installer.exe** file.
3. Follow the instructions
4. Driver will be installed automatically

### Install LAN Drivers

- A. Realtek RTL8111H-CG LAN Driver
  1. Open the **LAN** folder.
  2. Run the **Install\_Win10\_10050\_08132021.exe** file
  3. Follow the instructions
  4. Driver will be installed automatically
- B. Intel® I226 LAN Driver
  1. Open the **LAN** folder.

2. Run the **Setup.exe** file
3. Follow the instructions
4. Driver will be installed automatically

### Install ME Driver

1. Open the **ME** folder.
2. Run the **SetupME.exe** file
3. Follow the instructions
4. Driver will be installed automatically

### Install Serial IO Driver

1. Open the **Serial IO** folder.
2. Follow the instructions in the .inf files to manually install drivers.

### Install Audio Drivers

1. Open the **Audio Drivers** folder
2. Run the **Setup.exe** file
3. Follow the instructions
4. Drivers will be installed automatically

### Install Intel® SST Drivers (Optional)

1. Open the **Intel® SST Drivers** folder
2. Follow the instructions in the guide files to manually install drivers

# Appendix A

---

Mating Connectors

## A.1 List of Mating Connectors and Cables

The following table lists mating connectors and available cables.

Connector Label	Function	Mating Connector		Available Cable	AAEON Cable P/N
		Vendor	Model no		
CN1	RTC Battery	Molex	51021-0200	Battery Cable	175011301K
CN16	4-pin Smart Fan	Molex	51021-0400	N/A	N/A
CN17	I2C/SMBus Header	JST	SHR-05V-S-B	I2C/SMBUS Cable	170X000743
CN18	eSPI debug Header	JST	SHR-10V-S-B	eSPI debug Cable	1703100133
CN22	Front Panel	JST	SHR-10V-S-B	Front Panel Cable	170X000432
CN23	Power Input	Molex	19211-0003	Power Cable	170204010R
CN28	Audio	Molex	51021-0400	Audio cable	170X001201
CN31	4-bit GPIO Header	ACES	50224-00601-001	N/A	N/A
CN32	COM Port 1~2 Conn	JST	SHDR-40V-S-B	COM Port Cable	170X000568



# Appendix B

---

I/O Information



















































## B.1 I/O Address Map

---

- ▼  Input/output (IO)
  - >  [0000000000000000 - 0000000000000CF7] PCI Express Root Complex
  - >  [0000000000000D00 - 000000000000FFFF] PCI Express Root Complex









































---















































 (ISA) 0x0000004D (77)	Microsoft ACPI-Compliant System
 (ISA) 0x0000004E (78)	Microsoft ACPI-Compliant System
 (ISA) 0x0000004F (79)	Microsoft ACPI-Compliant System
 (ISA) 0x00000050 (80)	Microsoft ACPI-Compliant System
 (ISA) 0x00000051 (81)	Microsoft ACPI-Compliant System
 (ISA) 0x00000052 (82)	Microsoft ACPI-Compliant System
 (ISA) 0x00000053 (83)	Microsoft ACPI-Compliant System
 (ISA) 0x00000054 (84)	Microsoft ACPI-Compliant System
 (ISA) 0x00000055 (85)	Microsoft ACPI-Compliant System
 (ISA) 0x00000056 (86)	Microsoft ACPI-Compliant System
 (ISA) 0x00000057 (87)	Microsoft ACPI-Compliant System
 (ISA) 0x00000058 (88)	Microsoft ACPI-Compliant System
 (ISA) 0x00000059 (89)	Microsoft ACPI-Compliant System
 (ISA) 0x0000005A (90)	Microsoft ACPI-Compliant System
 (ISA) 0x0000005B (91)	Microsoft ACPI-Compliant System
 (ISA) 0x0000005C (92)	Microsoft ACPI-Compliant System
 (ISA) 0x0000005D (93)	Microsoft ACPI-Compliant System
 (ISA) 0x0000005E (94)	Microsoft ACPI-Compliant System
 (ISA) 0x0000005F (95)	Microsoft ACPI-Compliant System
 (ISA) 0x00000060 (96)	Microsoft ACPI-Compliant System
 (ISA) 0x00000061 (97)	Microsoft ACPI-Compliant System
 (ISA) 0x00000062 (98)	Microsoft ACPI-Compliant System
 (ISA) 0x00000063 (99)	Microsoft ACPI-Compliant System
 (ISA) 0x00000064 (100)	Microsoft ACPI-Compliant System
 (ISA) 0x00000065 (101)	Microsoft ACPI-Compliant System
 (ISA) 0x00000066 (102)	Microsoft ACPI-Compliant System
 (ISA) 0x00000067 (103)	Microsoft ACPI-Compliant System
 (ISA) 0x00000068 (104)	Microsoft ACPI-Compliant System
 (ISA) 0x00000069 (105)	Microsoft ACPI-Compliant System
 (ISA) 0x0000006A (106)	Microsoft ACPI-Compliant System
 (ISA) 0x0000006B (107)	Microsoft ACPI-Compliant System
 (ISA) 0x0000006C (108)	Microsoft ACPI-Compliant System
 (ISA) 0x0000006D (109)	Microsoft ACPI-Compliant System
 (ISA) 0x0000006E (110)	Microsoft ACPI-Compliant System
 (ISA) 0x0000006F (111)	Microsoft ACPI-Compliant System
 (ISA) 0x00000070 (112)	Microsoft ACPI-Compliant System
 (ISA) 0x00000071 (113)	Microsoft ACPI-Compliant System
 (ISA) 0x00000072 (114)	Microsoft ACPI-Compliant System
 (ISA) 0x00000073 (115)	Microsoft ACPI-Compliant System
 (ISA) 0x00000074 (116)	Microsoft ACPI-Compliant System
 (ISA) 0x00000075 (117)	Microsoft ACPI-Compliant System
 (ISA) 0x00000076 (118)	Microsoft ACPI-Compliant System
 (ISA) 0x00000077 (119)	Microsoft ACPI-Compliant System
 (ISA) 0x00000078 (120)	Microsoft ACPI-Compliant System
 (ISA) 0x00000079 (121)	Microsoft ACPI-Compliant System
 (ISA) 0x0000007A (122)	Microsoft ACPI-Compliant System
 (ISA) 0x0000007B (123)	Microsoft ACPI-Compliant System
 (ISA) 0x0000007C (124)	Microsoft ACPI-Compliant System
 (ISA) 0x0000007D (125)	Microsoft ACPI-Compliant System
 (ISA) 0x0000007E (126)	Microsoft ACPI-Compliant System
 (ISA) 0x0000007F (127)	Microsoft ACPI-Compliant System

---



















































---

 (ISA) 0x00000080 (128)	Microsoft ACPI-Compliant System
 (ISA) 0x00000081 (129)	Microsoft ACPI-Compliant System
 (ISA) 0x00000082 (130)	Microsoft ACPI-Compliant System
 (ISA) 0x00000083 (131)	Microsoft ACPI-Compliant System
 (ISA) 0x00000084 (132)	Microsoft ACPI-Compliant System
 (ISA) 0x00000085 (133)	Microsoft ACPI-Compliant System
 (ISA) 0x00000086 (134)	Microsoft ACPI-Compliant System
 (ISA) 0x00000087 (135)	Microsoft ACPI-Compliant System
 (ISA) 0x00000088 (136)	Microsoft ACPI-Compliant System
 (ISA) 0x00000089 (137)	Microsoft ACPI-Compliant System
 (ISA) 0x0000008A (138)	Microsoft ACPI-Compliant System
 (ISA) 0x0000008B (139)	Microsoft ACPI-Compliant System
 (ISA) 0x0000008C (140)	Microsoft ACPI-Compliant System
 (ISA) 0x0000008D (141)	Microsoft ACPI-Compliant System
 (ISA) 0x0000008E (142)	Microsoft ACPI-Compliant System
 (ISA) 0x0000008F (143)	Microsoft ACPI-Compliant System
 (ISA) 0x00000090 (144)	Microsoft ACPI-Compliant System
 (ISA) 0x00000091 (145)	Microsoft ACPI-Compliant System
 (ISA) 0x00000092 (146)	Microsoft ACPI-Compliant System
 (ISA) 0x00000093 (147)	Microsoft ACPI-Compliant System
 (ISA) 0x00000094 (148)	Microsoft ACPI-Compliant System
 (ISA) 0x00000095 (149)	Microsoft ACPI-Compliant System
 (ISA) 0x00000096 (150)	Microsoft ACPI-Compliant System
 (ISA) 0x00000097 (151)	Microsoft ACPI-Compliant System
 (ISA) 0x00000098 (152)	Microsoft ACPI-Compliant System
 (ISA) 0x00000099 (153)	Microsoft ACPI-Compliant System
 (ISA) 0x0000009A (154)	Microsoft ACPI-Compliant System
 (ISA) 0x0000009B (155)	Microsoft ACPI-Compliant System
 (ISA) 0x0000009C (156)	Microsoft ACPI-Compliant System
 (ISA) 0x0000009D (157)	Microsoft ACPI-Compliant System
 (ISA) 0x0000009E (158)	Microsoft ACPI-Compliant System
 (ISA) 0x0000009F (159)	Microsoft ACPI-Compliant System
 (ISA) 0x000000A0 (160)	Microsoft ACPI-Compliant System
 (ISA) 0x000000A1 (161)	Microsoft ACPI-Compliant System
 (ISA) 0x000000A2 (162)	Microsoft ACPI-Compliant System
 (ISA) 0x000000A3 (163)	Microsoft ACPI-Compliant System
 (ISA) 0x000000A4 (164)	Microsoft ACPI-Compliant System
 (ISA) 0x000000A5 (165)	Microsoft ACPI-Compliant System
 (ISA) 0x000000A6 (166)	Microsoft ACPI-Compliant System
(ISA) 0x000000A7 (167)	Microsoft ACPI-Compliant System
(ISA) 0x000000A8 (168)	Microsoft ACPI-Compliant System
(ISA) 0x000000A9 (169)	Microsoft ACPI-Compliant System
(ISA) 0x000000AA (170)	Microsoft ACPI-Compliant System
(ISA) 0x000000AB (171)	Microsoft ACPI-Compliant System
(ISA) 0x000000AC (172)	Microsoft ACPI-Compliant System
(ISA) 0x000000AD (173)	Microsoft ACPI-Compliant System
(ISA) 0x000000AE (174)	Microsoft ACPI-Compliant System
(ISA) 0x000000AF (175)	Microsoft ACPI-Compliant System
(ISA) 0x000000B0 (176)	Microsoft ACPI-Compliant System
(ISA) 0x000000B1 (177)	Microsoft ACPI-Compliant System
(ISA) 0x000000B2 (178)	Microsoft ACPI-Compliant System

---



















































 (ISA) 0x000000B3 (179)	Microsoft ACPI-Compliant System
 (ISA) 0x000000B4 (180)	Microsoft ACPI-Compliant System
 (ISA) 0x000000B5 (181)	Microsoft ACPI-Compliant System
 (ISA) 0x000000B6 (182)	Microsoft ACPI-Compliant System
 (ISA) 0x000000B7 (183)	Microsoft ACPI-Compliant System
 (ISA) 0x000000B8 (184)	Microsoft ACPI-Compliant System
 (ISA) 0x000000B9 (185)	Microsoft ACPI-Compliant System
 (ISA) 0x000000BA (186)	Microsoft ACPI-Compliant System
 (ISA) 0x000000BB (187)	Microsoft ACPI-Compliant System
 (ISA) 0x000000BC (188)	Microsoft ACPI-Compliant System
 (ISA) 0x000000BD (189)	Microsoft ACPI-Compliant System
 (ISA) 0x000000BE (190)	Microsoft ACPI-Compliant System
 (ISA) 0x000000BF (191)	Microsoft ACPI-Compliant System
 (ISA) 0x000000C0 (192)	Microsoft ACPI-Compliant System
 (ISA) 0x000000C1 (193)	Microsoft ACPI-Compliant System
 (ISA) 0x000000C2 (194)	Microsoft ACPI-Compliant System
 (ISA) 0x000000C3 (195)	Microsoft ACPI-Compliant System
 (ISA) 0x000000C4 (196)	Microsoft ACPI-Compliant System
 (ISA) 0x000000C5 (197)	Microsoft ACPI-Compliant System
 (ISA) 0x000000C6 (198)	Microsoft ACPI-Compliant System
 (ISA) 0x000000C7 (199)	Microsoft ACPI-Compliant System
 (ISA) 0x000000C8 (200)	Microsoft ACPI-Compliant System
 (ISA) 0x000000C9 (201)	Microsoft ACPI-Compliant System
 (ISA) 0x000000CA (202)	Microsoft ACPI-Compliant System
 (ISA) 0x000000CB (203)	Microsoft ACPI-Compliant System
 (ISA) 0x000000CC (204)	Microsoft ACPI-Compliant System
 (ISA) 0x00000100 (256)	Microsoft ACPI-Compliant System
 (ISA) 0x00000101 (257)	Microsoft ACPI-Compliant System
 (ISA) 0x00000102 (258)	Microsoft ACPI-Compliant System
 (ISA) 0x00000103 (259)	Microsoft ACPI-Compliant System
 (ISA) 0x00000104 (260)	Microsoft ACPI-Compliant System
 (ISA) 0x00000105 (261)	Microsoft ACPI-Compliant System
 (ISA) 0x00000106 (262)	Microsoft ACPI-Compliant System
 (ISA) 0x00000107 (263)	Microsoft ACPI-Compliant System
 (ISA) 0x00000108 (264)	Microsoft ACPI-Compliant System
 (ISA) 0x00000109 (265)	Microsoft ACPI-Compliant System
 (ISA) 0x0000010A (266)	Microsoft ACPI-Compliant System
 (ISA) 0x0000010B (267)	Microsoft ACPI-Compliant System
 (ISA) 0x0000010C (268)	Microsoft ACPI-Compliant System
 (ISA) 0x0000010D (269)	Microsoft ACPI-Compliant System
 (ISA) 0x0000010E (270)	Microsoft ACPI-Compliant System
 (ISA) 0x0000010F (271)	Microsoft ACPI-Compliant System
 (ISA) 0x00000110 (272)	Microsoft ACPI-Compliant System
 (ISA) 0x00000111 (273)	Microsoft ACPI-Compliant System
 (ISA) 0x00000112 (274)	Microsoft ACPI-Compliant System
 (ISA) 0x00000113 (275)	Microsoft ACPI-Compliant System
 (ISA) 0x00000114 (276)	Microsoft ACPI-Compliant System
(ISA) 0x00000115 (277)	Microsoft ACPI-Compliant System
(ISA) 0x00000116 (278)	Microsoft ACPI-Compliant System
(ISA) 0x00000117 (279)	Microsoft ACPI-Compliant System
(ISA) 0x00000118 (280)	Microsoft ACPI-Compliant System

---

 (ISA) 0x00000119 (281)	Microsoft ACPI-Compliant System
 (ISA) 0x0000011A (282)	Microsoft ACPI-Compliant System
 (ISA) 0x0000011B (283)	Microsoft ACPI-Compliant System
 (ISA) 0x0000011C (284)	Microsoft ACPI-Compliant System
 (ISA) 0x0000011D (285)	Microsoft ACPI-Compliant System
 (ISA) 0x0000011E (286)	Microsoft ACPI-Compliant System
 (ISA) 0x0000011F (287)	Microsoft ACPI-Compliant System
 (ISA) 0x00000120 (288)	Microsoft ACPI-Compliant System
 (ISA) 0x00000121 (289)	Microsoft ACPI-Compliant System
 (ISA) 0x00000122 (290)	Microsoft ACPI-Compliant System
 (ISA) 0x00000123 (291)	Microsoft ACPI-Compliant System
 (ISA) 0x00000124 (292)	Microsoft ACPI-Compliant System
 (ISA) 0x00000125 (293)	Microsoft ACPI-Compliant System
 (ISA) 0x00000126 (294)	Microsoft ACPI-Compliant System
 (ISA) 0x00000127 (295)	Microsoft ACPI-Compliant System
 (ISA) 0x00000128 (296)	Microsoft ACPI-Compliant System
 (ISA) 0x00000129 (297)	Microsoft ACPI-Compliant System
 (ISA) 0x0000012A (298)	Microsoft ACPI-Compliant System
 (ISA) 0x0000012B (299)	Microsoft ACPI-Compliant System
 (ISA) 0x0000012C (300)	Microsoft ACPI-Compliant System
 (ISA) 0x0000012D (301)	Microsoft ACPI-Compliant System
 (ISA) 0x0000012E (302)	Microsoft ACPI-Compliant System
 (ISA) 0x0000012F (303)	Microsoft ACPI-Compliant System
 (ISA) 0x00000130 (304)	Microsoft ACPI-Compliant System
 (ISA) 0x00000131 (305)	Microsoft ACPI-Compliant System
 (ISA) 0x00000132 (306)	Microsoft ACPI-Compliant System
 (ISA) 0x00000133 (307)	Microsoft ACPI-Compliant System
 (ISA) 0x00000134 (308)	Microsoft ACPI-Compliant System
 (ISA) 0x00000135 (309)	Microsoft ACPI-Compliant System
 (ISA) 0x00000136 (310)	Microsoft ACPI-Compliant System
 (ISA) 0x00000137 (311)	Microsoft ACPI-Compliant System
 (ISA) 0x00000138 (312)	Microsoft ACPI-Compliant System
 (ISA) 0x00000139 (313)	Microsoft ACPI-Compliant System
 (ISA) 0x0000013A (314)	Microsoft ACPI-Compliant System
 (ISA) 0x0000013B (315)	Microsoft ACPI-Compliant System
 (ISA) 0x0000013C (316)	Microsoft ACPI-Compliant System
 (ISA) 0x0000013D (317)	Microsoft ACPI-Compliant System
 (ISA) 0x0000013E (318)	Microsoft ACPI-Compliant System
 (ISA) 0x0000013F (319)	Microsoft ACPI-Compliant System
 (ISA) 0x00000140 (320)	Microsoft ACPI-Compliant System
 (ISA) 0x00000141 (321)	Microsoft ACPI-Compliant System
 (ISA) 0x00000142 (322)	Microsoft ACPI-Compliant System
 (ISA) 0x00000143 (323)	Microsoft ACPI-Compliant System
 (ISA) 0x00000144 (324)	Microsoft ACPI-Compliant System
 (ISA) 0x00000145 (325)	Microsoft ACPI-Compliant System
 (ISA) 0x00000146 (326)	Microsoft ACPI-Compliant System
 (ISA) 0x00000147 (327)	Microsoft ACPI-Compliant System
 (ISA) 0x00000148 (328)	Microsoft ACPI-Compliant System
 (ISA) 0x00000149 (329)	Microsoft ACPI-Compliant System
 (ISA) 0x0000014A (330)	Microsoft ACPI-Compliant System
 (ISA) 0x0000014B (331)	Microsoft ACPI-Compliant System



















































---















































---













































 (ISA) 0x0000014C (332)	Microsoft ACPI-Compliant System
 (ISA) 0x0000014D (333)	Microsoft ACPI-Compliant System
 (ISA) 0x0000014E (334)	Microsoft ACPI-Compliant System
 (ISA) 0x0000014F (335)	Microsoft ACPI-Compliant System
 (ISA) 0x00000150 (336)	Microsoft ACPI-Compliant System
 (ISA) 0x00000151 (337)	Microsoft ACPI-Compliant System
 (ISA) 0x00000152 (338)	Microsoft ACPI-Compliant System
 (ISA) 0x00000153 (339)	Microsoft ACPI-Compliant System
 (ISA) 0x00000154 (340)	Microsoft ACPI-Compliant System
 (ISA) 0x00000155 (341)	Microsoft ACPI-Compliant System
 (ISA) 0x00000156 (342)	Microsoft ACPI-Compliant System
 (ISA) 0x00000157 (343)	Microsoft ACPI-Compliant System
 (ISA) 0x00000158 (344)	Microsoft ACPI-Compliant System
 (ISA) 0x00000159 (345)	Microsoft ACPI-Compliant System
 (ISA) 0x0000015A (346)	Microsoft ACPI-Compliant System
 (ISA) 0x0000015B (347)	Microsoft ACPI-Compliant System
 (ISA) 0x0000015C (348)	Microsoft ACPI-Compliant System
 (ISA) 0x0000015D (349)	Microsoft ACPI-Compliant System
 (ISA) 0x0000015E (350)	Microsoft ACPI-Compliant System
 (ISA) 0x0000015F (351)	Microsoft ACPI-Compliant System
 (ISA) 0x00000160 (352)	Microsoft ACPI-Compliant System
 (ISA) 0x00000161 (353)	Microsoft ACPI-Compliant System
 (ISA) 0x00000162 (354)	Microsoft ACPI-Compliant System
 (ISA) 0x00000163 (355)	Microsoft ACPI-Compliant System
 (ISA) 0x00000164 (356)	Microsoft ACPI-Compliant System
 (ISA) 0x00000165 (357)	Microsoft ACPI-Compliant System
 (ISA) 0x00000166 (358)	Microsoft ACPI-Compliant System
 (ISA) 0x00000167 (359)	Microsoft ACPI-Compliant System
 (ISA) 0x00000168 (360)	Microsoft ACPI-Compliant System
 (ISA) 0x00000169 (361)	Microsoft ACPI-Compliant System
 (ISA) 0x0000016A (362)	Microsoft ACPI-Compliant System
 (ISA) 0x0000016B (363)	Microsoft ACPI-Compliant System
 (ISA) 0x0000016C (364)	Microsoft ACPI-Compliant System
 (ISA) 0x0000016D (365)	Microsoft ACPI-Compliant System
 (ISA) 0x0000016E (366)	Microsoft ACPI-Compliant System
 (ISA) 0x0000016F (367)	Microsoft ACPI-Compliant System
 (ISA) 0x00000170 (368)	Microsoft ACPI-Compliant System
 (ISA) 0x00000171 (369)	Microsoft ACPI-Compliant System
 (ISA) 0x00000172 (370)	Microsoft ACPI-Compliant System
 (ISA) 0x00000173 (371)	Microsoft ACPI-Compliant System
 (ISA) 0x00000174 (372)	Microsoft ACPI-Compliant System
 (ISA) 0x00000175 (373)	Microsoft ACPI-Compliant System
 (ISA) 0x00000176 (374)	Microsoft ACPI-Compliant System
 (ISA) 0x00000177 (375)	Microsoft ACPI-Compliant System
 (ISA) 0x00000178 (376)	Microsoft ACPI-Compliant System
 (ISA) 0x00000179 (377)	Microsoft ACPI-Compliant System
 (ISA) 0x0000017A (378)	Microsoft ACPI-Compliant System
 (ISA) 0x0000017B (379)	Microsoft ACPI-Compliant System
 (ISA) 0x0000017C (380)	Microsoft ACPI-Compliant System
 (ISA) 0x0000017D (381)	Microsoft ACPI-Compliant System
 (ISA) 0x0000017E (382)	Microsoft ACPI-Compliant System

---

---



 (ISA) 0x0000017F (383)	Microsoft ACPI-Compliant System
 (ISA) 0x00000180 (384)	Microsoft ACPI-Compliant System
 (ISA) 0x00000181 (385)	Microsoft ACPI-Compliant System
 (ISA) 0x00000182 (386)	Microsoft ACPI-Compliant System
 (ISA) 0x00000183 (387)	Microsoft ACPI-Compliant System
 (ISA) 0x00000184 (388)	Microsoft ACPI-Compliant System
 (ISA) 0x00000185 (389)	Microsoft ACPI-Compliant System
 (ISA) 0x00000186 (390)	Microsoft ACPI-Compliant System
 (ISA) 0x00000187 (391)	Microsoft ACPI-Compliant System
 (ISA) 0x00000188 (392)	Microsoft ACPI-Compliant System
 (ISA) 0x00000189 (393)	Microsoft ACPI-Compliant System
 (ISA) 0x0000018A (394)	Microsoft ACPI-Compliant System
 (ISA) 0x0000018B (395)	Microsoft ACPI-Compliant System
 (ISA) 0x0000018C (396)	Microsoft ACPI-Compliant System
 (ISA) 0x0000018D (397)	Microsoft ACPI-Compliant System
 (ISA) 0x0000018E (398)	Microsoft ACPI-Compliant System
 (ISA) 0x0000018F (399)	Microsoft ACPI-Compliant System
 (ISA) 0x00000190 (400)	Microsoft ACPI-Compliant System
 (ISA) 0x00000191 (401)	Microsoft ACPI-Compliant System
 (ISA) 0x00000192 (402)	Microsoft ACPI-Compliant System
 (ISA) 0x00000193 (403)	Microsoft ACPI-Compliant System
 (ISA) 0x00000194 (404)	Microsoft ACPI-Compliant System
 (ISA) 0x00000195 (405)	Microsoft ACPI-Compliant System
 (ISA) 0x00000196 (406)	Microsoft ACPI-Compliant System
 (ISA) 0x00000197 (407)	Microsoft ACPI-Compliant System
 (ISA) 0x00000198 (408)	Microsoft ACPI-Compliant System
 (ISA) 0x00000199 (409)	Microsoft ACPI-Compliant System
 (ISA) 0x0000019A (410)	Microsoft ACPI-Compliant System
 (ISA) 0x0000019B (411)	Microsoft ACPI-Compliant System
 (ISA) 0x0000019C (412)	Microsoft ACPI-Compliant System
 (ISA) 0x0000019D (413)	Microsoft ACPI-Compliant System
 (ISA) 0x0000019E (414)	Microsoft ACPI-Compliant System
 (ISA) 0x0000019F (415)	Microsoft ACPI-Compliant System
 (ISA) 0x000001A0 (416)	Microsoft ACPI-Compliant System
 (ISA) 0x000001A1 (417)	Microsoft ACPI-Compliant System
 (ISA) 0x000001A2 (418)	Microsoft ACPI-Compliant System
 (ISA) 0x000001A3 (419)	Microsoft ACPI-Compliant System
 (ISA) 0x000001A4 (420)	Microsoft ACPI-Compliant System
 (ISA) 0x000001A5 (421)	Microsoft ACPI-Compliant System
 (ISA) 0x000001A6 (422)	Microsoft ACPI-Compliant System
 (ISA) 0x000001A7 (423)	Microsoft ACPI-Compliant System
 (ISA) 0x000001A8 (424)	Microsoft ACPI-Compliant System
 (ISA) 0x000001A9 (425)	Microsoft ACPI-Compliant System
 (ISA) 0x000001AA (426)	Microsoft ACPI-Compliant System
 (ISA) 0x000001AB (427)	Microsoft ACPI-Compliant System
 (ISA) 0x000001AC (428)	Microsoft ACPI-Compliant System
 (ISA) 0x000001AD (429)	Microsoft ACPI-Compliant System
 (ISA) 0x000001AE (430)	Microsoft ACPI-Compliant System
 (ISA) 0x000001AF (431)	Microsoft ACPI-Compliant System
 (ISA) 0x000001B0 (432)	Microsoft ACPI-Compliant System
 (ISA) 0x000001B1 (433)	Microsoft ACPI-Compliant System

 (ISA) 0x000001B2 (434)	Microsoft ACPI-Compliant System
 (ISA) 0x000001B3 (435)	Microsoft ACPI-Compliant System
 (ISA) 0x000001B4 (436)	Microsoft ACPI-Compliant System
 (ISA) 0x000001B5 (437)	Microsoft ACPI-Compliant System
 (ISA) 0x000001B6 (438)	Microsoft ACPI-Compliant System
 (ISA) 0x000001B7 (439)	Microsoft ACPI-Compliant System
 (ISA) 0x000001B8 (440)	Microsoft ACPI-Compliant System
 (ISA) 0x000001B9 (441)	Microsoft ACPI-Compliant System
 (ISA) 0x000001BA (442)	Microsoft ACPI-Compliant System
 (ISA) 0x000001BB (443)	Microsoft ACPI-Compliant System
 (ISA) 0x000001BC (444)	Microsoft ACPI-Compliant System
 (ISA) 0x000001BD (445)	Microsoft ACPI-Compliant System
 (ISA) 0x000001BE (446)	Microsoft ACPI-Compliant System
 (ISA) 0x000001BF (447)	Microsoft ACPI-Compliant System
 (ISA) 0x000001C0 (448)	Microsoft ACPI-Compliant System
 (ISA) 0x000001C1 (449)	Microsoft ACPI-Compliant System
 (ISA) 0x000001C2 (450)	Microsoft ACPI-Compliant System
 (ISA) 0x000001C3 (451)	Microsoft ACPI-Compliant System
 (ISA) 0x000001C4 (452)	Microsoft ACPI-Compliant System
 (ISA) 0x000001C5 (453)	Microsoft ACPI-Compliant System
 (ISA) 0x000001C6 (454)	Microsoft ACPI-Compliant System
 (ISA) 0x000001C7 (455)	Microsoft ACPI-Compliant System
 (ISA) 0x000001C8 (456)	Microsoft ACPI-Compliant System
 (ISA) 0x000001C9 (457)	Microsoft ACPI-Compliant System
 (ISA) 0x000001CA (458)	Microsoft ACPI-Compliant System
 (ISA) 0x000001CB (459)	Microsoft ACPI-Compliant System
 (ISA) 0x000001CC (460)	Microsoft ACPI-Compliant System
 (ISA) 0x000001CD (461)	Microsoft ACPI-Compliant System
 (ISA) 0x000001CE (462)	Microsoft ACPI-Compliant System
 (ISA) 0x000001CF (463)	Microsoft ACPI-Compliant System
 (ISA) 0x000001D0 (464)	Microsoft ACPI-Compliant System
 (ISA) 0x000001D1 (465)	Microsoft ACPI-Compliant System
 (ISA) 0x000001D2 (466)	Microsoft ACPI-Compliant System
 (ISA) 0x000001D3 (467)	Microsoft ACPI-Compliant System
 (ISA) 0x000001D4 (468)	Microsoft ACPI-Compliant System
 (ISA) 0x000001D5 (469)	Microsoft ACPI-Compliant System
 (ISA) 0x000001D6 (470)	Microsoft ACPI-Compliant System
 (ISA) 0x000001D7 (471)	Microsoft ACPI-Compliant System
 (ISA) 0x000001D8 (472)	Microsoft ACPI-Compliant System
 (ISA) 0x000001D9 (473)	Microsoft ACPI-Compliant System
 (ISA) 0x000001DA (474)	Microsoft ACPI-Compliant System
 (ISA) 0x000001DB (475)	Microsoft ACPI-Compliant System
 (ISA) 0x000001DC (476)	Microsoft ACPI-Compliant System
 (ISA) 0x000001DD (477)	Microsoft ACPI-Compliant System
 (ISA) 0x000001DE (478)	Microsoft ACPI-Compliant System
 (ISA) 0x000001DF (479)	Microsoft ACPI-Compliant System
 (ISA) 0x000001E0 (480)	Microsoft ACPI-Compliant System
(ISA) 0x000001E1 (481)	Microsoft ACPI-Compliant System
(ISA) 0x000001E2 (482)	Microsoft ACPI-Compliant System
(ISA) 0x000001E3 (483)	Microsoft ACPI-Compliant System
(ISA) 0x000001E4 (484)	Microsoft ACPI-Compliant System

	(ISA) 0x000001E5 (485)	Microsoft ACPI-Compliant System
	(ISA) 0x000001E6 (486)	Microsoft ACPI-Compliant System
	(ISA) 0x000001E7 (487)	Microsoft ACPI-Compliant System
	(ISA) 0x000001E8 (488)	Microsoft ACPI-Compliant System
	(ISA) 0x000001E9 (489)	Microsoft ACPI-Compliant System
	(ISA) 0x000001EA (490)	Microsoft ACPI-Compliant System
	(ISA) 0x000001EB (491)	Microsoft ACPI-Compliant System
	(ISA) 0x000001EC (492)	Microsoft ACPI-Compliant System
	(ISA) 0x000001ED (493)	Microsoft ACPI-Compliant System
	(ISA) 0x000001EE (494)	Microsoft ACPI-Compliant System
	(ISA) 0x000001EF (495)	Microsoft ACPI-Compliant System
	(ISA) 0x000001F0 (496)	Microsoft ACPI-Compliant System
	(ISA) 0x000001F1 (497)	Microsoft ACPI-Compliant System
	(ISA) 0x000001F2 (498)	Microsoft ACPI-Compliant System
	(ISA) 0x000001F3 (499)	Microsoft ACPI-Compliant System
	(ISA) 0x000001F4 (500)	Microsoft ACPI-Compliant System
	(ISA) 0x000001F5 (501)	Microsoft ACPI-Compliant System
	(ISA) 0x000001F6 (502)	Microsoft ACPI-Compliant System
	(ISA) 0x000001F7 (503)	Microsoft ACPI-Compliant System
	(ISA) 0x000001F8 (504)	Microsoft ACPI-Compliant System
	(ISA) 0x000001F9 (505)	Microsoft ACPI-Compliant System
	(ISA) 0x000001FA (506)	Microsoft ACPI-Compliant System
	(ISA) 0x000001FB (507)	Microsoft ACPI-Compliant System
	(ISA) 0x000001FC (508)	Microsoft ACPI-Compliant System
	(ISA) 0x000001FD (509)	Microsoft ACPI-Compliant System
	(ISA) 0x000001FE (510)	Microsoft ACPI-Compliant System
	(ISA) 0x000001FF (511)	Microsoft ACPI-Compliant System
	(PCI) 0x00000010 (16)	Intel(R) Serial IO UART Host Controller - 54A8
	(PCI) 0x00000013 (19)	High Definition Audio Controller
	(PCI) 0x0000001B (27)	Intel(R) Serial IO I2C Host Controller - 54E8
	(PCI) 0xFFFFFFF1 (-15)	Intel(R) Management Engine Interface #1
	(PCI) 0xFFFFFFF2 (-14)	Intel(R) Ethernet Controller I226-IT #2
	(PCI) 0xFFFFFFF3 (-13)	Intel(R) Ethernet Controller I226-IT #2
	(PCI) 0xFFFFFFF4 (-12)	Intel(R) Ethernet Controller I226-IT #2
	(PCI) 0xFFFFFFF5 (-11)	Intel(R) Ethernet Controller I226-IT #2
	(PCI) 0xFFFFFFF6 (-10)	Intel(R) Ethernet Controller I226-IT #2
	(PCI) 0xFFFFFFF7 (-9)	Intel(R) Ethernet Controller I226-IT #2
	(PCI) 0xFFFFFFF8 (-8)	Intel(R) Ethernet Controller I226-IT #2
	(PCI) 0xFFFFFFF9 (-7)	Intel(R) Ethernet Controller I226-IT #2
	(PCI) 0xFFFFFFFA (-6)	Intel(R) Ethernet Controller I226-IT #2
	(PCI) 0xFFFFFFFB (-5)	Intel(R) UHD Graphics
	(PCI) 0xFFFFFFFC (-4)	Intel(R) USB 3.1o eXtensible Host Controller - 1.20 (Microsoft)
	(PCI) 0xFFFFFFF9 (-3)	Realtek PCIe GbE Family Controller
	(PCI) 0xFFFFFFF2 (-2)	Standard SATA AHCI Controller















## B.3 Large Memory Map

---

- ▼  Large Memory
  -  [\[0000004000000000 - 0000007FFFFFFFFF\] PCI Express Root Complex](#)

## B.4 Memory Address Map

Memory	
[0000000000A0000 - 0000000000BFFFF]	PCI Express Root Complex
> [000000004F400000 - 000000004F5FFFFF]	PCI Express Root Port
[000000004F620000 - 000000004F621FFF]	Standard SATA AHCI Controller
[000000004F622000 - 000000004F6227FF]	Standard SATA AHCI Controller
[000000004F623000 - 000000004F6230FF]	Standard SATA AHCI Controller
[000000007FC00000 - 000000007FCFFFFF]	PCI Express Root Port
[000000007FD00000 - 000000007FDFFFFF]	PCI Express Root Port
[000000007FE00000 - 000000007FE01FFF]	Standard SATA AHCI Controller
[000000007FE02000 - 000000007FE027FF]	Standard SATA AHCI Controller
[000000007FE03000 - 000000007FE030FF]	Standard SATA AHCI Controller
> [0000000080000000 - 000000008FFFFFFF]	Microsoft Basic Display Adapter
> [0000000080400000 - 000000008BFFFFFFF]	PCI Express Root Complex
[00000000C0000000 - 00000000CFFFFFFF]	Motherboard resources
[00000000DC000000 - 00000000DC00653]	Intel(R) Serial IO GPIO Host Controller - INT3452
[00000000DC400000 - 00000000DC40763]	Intel(R) Serial IO GPIO Host Controller - INT3452
[00000000DC500000 - 00000000DC5076B]	Intel(R) Serial IO GPIO Host Controller - INT3452
[00000000DC700000 - 00000000DC70673]	Intel(R) Serial IO GPIO Host Controller - INT3452
[00000000E0690000 - 00000000E069FFFF]	Intel(R) Serial IO GPIO Host Controller - INTC1056
[00000000E06A0000 - 00000000E06AFFFF]	Intel(R) Serial IO GPIO Host Controller - INTC1056
[00000000E06B0000 - 00000000E06BFFFF]	Intel(R) Serial IO GPIO Host Controller - INTC1056
[00000000E06D0000 - 00000000E06DFFFF]	Intel(R) Serial IO GPIO Host Controller - INTC1056
[00000000E06E0000 - 00000000E06EFFFF]	Intel(R) Serial IO GPIO Host Controller - INTC1056
[00000000E0D10000 - 00000000E0D1FFFF]	Intel(R) Serial IO GPIO Host Controller - INTC1083
[00000000E0D20000 - 00000000E0D2FFFF]	Intel(R) Serial IO GPIO Host Controller - INTC1083
[00000000E0D30000 - 00000000E0D3FFFF]	Intel(R) Serial IO GPIO Host Controller - INTC1083
[00000000E0D40000 - 00000000E0D4FFFF]	Intel(R) Serial IO GPIO Host Controller - INTC1083
[00000000E0D50000 - 00000000E0D5FFFF]	Intel(R) Serial IO GPIO Host Controller - INTC1083
[00000000FD000000 - 00000000FD68FFFF]	Motherboard resources
> [00000000FD690000 - 00000000FD69FFFF]	Intel(R) Serial IO GPIO Host Controller - INTC1057
[00000000FD6A0000 - 00000000FD6AFFFF]	Intel(R) Serial IO GPIO Host Controller - INTC1057
> [00000000FD6B0000 - 00000000FD6CFFFF]	Motherboard resources
> [00000000FD6D0000 - 00000000FD6DFFFF]	Intel(R) Serial IO GPIO Host Controller - INTC1057
> [00000000FD6E0000 - 00000000FD6EFFFF]	Intel(R) Serial IO GPIO Host Controller - INTC1057
[00000000FD6F0000 - 00000000FDFFFFFFF]	Motherboard resources
> [00000000FE000000 - 00000000FE01FFFF]	Motherboard resources
[00000000FE050000 - 00000000FE053FFF]	Intel(R) Platform Services Engine DMA Controller
[00000000FE060000 - 00000000FE063FFF]	Intel(R) Platform Services Engine DMA Controller
[00000000FE200000 - 00000000FE7FFFFFFF]	Motherboard resources
[00000000FED00000 - 00000000FED003FF]	High precision event timer
> [00000000FED20000 - 00000000FED7FFFF]	Motherboard resources
[00000000FED45000 - 00000000FED8FFFF]	Motherboard resources
[00000000FED90000 - 00000000FED93FFF]	Motherboard resources
[00000000FEDA0000 - 00000000FEDA0FFF]	Motherboard resources
[00000000FEDA1000 - 00000000FEDA1FFF]	Motherboard resources
[00000000FEDC0000 - 00000000FEDC7FFF]	Motherboard resources
[00000000FEE00000 - 00000000FEEFFFFFFF]	Motherboard resources
[00000000FF000000 - 00000000FFFFFFF]	Motherboard resources
> [0000004000000000 - 000000400FFFFFFF]	Intel(R) UHD Graphics
[0000004017000000 - 0000004017FFFFFFF]	Intel(R) Graphics

-  [0000004020240000 - 000000402024FFFF] Intel(R) USB 3.20 eXtensible Host Controller - 1.20 (Microsoft)
  -  [0000004020250000 - 000000402025FFFF] Intel(R) USB 3.20 eXtensible Host Controller - 1.20 (Microsoft)
  -  [0000004020268000 - 00000040202680FF] SM Bus Controller
  -  [000000402026A000 - 000000402026AFFF] Intel(R) Management Engine Interface #1
  -  [000000402026B000 - 000000402026BFFF] Intel(R) Serial IO I2C Host Controller - 7E79
  -  [000000402026C000 - 000000402026CFFF] Intel(R) Serial IO I2C Host Controller - 7E78
  - >  [0000006000000000 - 0000006000FFFF] Intel(R) UHD Graphics
  - >  [0000006001000000 - 0000006001FFFF] Intel(R) UHD Graphics 730
  -  [0000006002100000 - 000000600210FFFF] Intel(R) USB 3.20 eXtensible Host Controller - 1.20 (Microsoft)
  -  [0000006002118000 - 00000060021180FF] Intel(R) SMBus - 7AA3
  -  [0000007FFFEF9000 - 0000007FFFEF9FFF] Intel(R) Serial IO UART Host Controller - 54A8
  -  [0000007FFFEFA000 - 0000007FFFEFAFFF] Intel(R) Serial IO I2C Host Controller - 54E8
  -  [0000007FFFEFB000 - 0000007FFFEFBFFF] Intel(R) Management Engine Interface #1
  -  [0000007FFFEFC000 - 0000007FFFEFCFFF] High Definition Audio Controller
  -  [0000007FFFEFD000 - 0000007FFFEFDFFF] High Definition Audio Controller
-

# Appendix C

---

## Watchdog Timer Programming

## C.1 Introduction to Watchdog Timer

---

This section details how to set up and program the Watchdog Timer for your AAEON system or board. The watchdog timer is used to automatically detect malfunctions and recover the system. During normal operation, the system will regularly send a signal to reset the watchdog timer. If the system does not reset the watchdog timer, it will timeout and force the system into recovery and/or reboot.

The following sections refer to additional software used for programming your board, such as the AAEON Framework, AAEON SDK and AAEON Windows EAPI. If you need assistance with utilizing these tools, programming your Watchdog Timer, or would like additional documentation on these resources, contact your AAEON representative or visit our support page at <https://www.aaeon.com/en/support/>

## C.2 Programing the Watchdog Timer with AAEON SDK

If you have installed the AAEON Framework, you can program the Watchdog Timer using the AAEON SDK. Simply locate where the SDK is installed, and double click the icon. The following dialog box will appear:

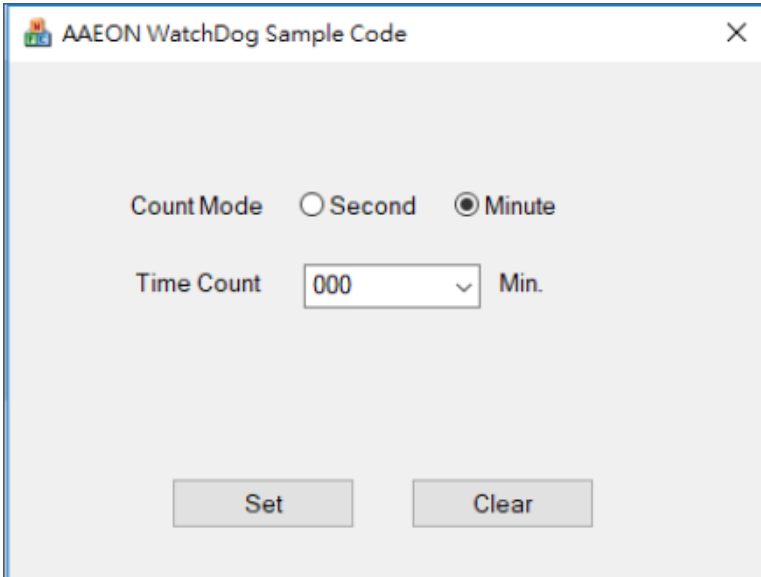

**Count Mode:** Set Watchdog Timer to count in minutes or seconds.

**Time Count:** The length of time (in minutes or seconds) before the Watchdog Timer will initiate a system recovery/ reboot.

**Set:** After selecting Count Mode and Time Count, this will save your changes and enable the Watchdog Timer function.

**Clear:** This will reset settings and disable the Watchdog Timer function.

### C.3 Programing Watchdog Timer with AAEON Windows EAPI

AAEON Framework (KMDF Driver) must be installed before calling these functions.

**EapiLibInitialize()** should be the first to call before calling other EAPI functions.

**EapiLibUnInitialize()** should be called to release resources before program exit.

When building C/C++ apps, Lib (Library, aaeonEAPI.lib) is needed.

aaeonEAPI.lib is needed for C/C++ based app, make sure the lib files and executable files are in the same folder.

The following shows how to build and run codes:

There are two scenarios to invoke Watchdog Timer functions:

1. Use **EApiWDogStart**

After EApiWDogStart

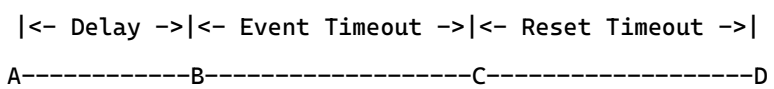

2. Use **EApiWDogTrigger**

After EApiWDogTrigger

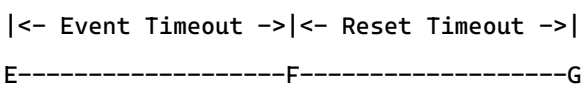

**Stage A:** Watchdog is started.

**Stage B:** Initial Delay Period.

**Stage C/F:** Event is triggered, NMI, IRQ, or PIN is Triggered. This allows for possible Software Recovery.

**Stage D/G:** System is reset.

**Stage E:** Watchdog is Triggered.

**EapiWDogStop** must be called before Stage C/F to prevent event from being generated.

**EapiWDogStop** must be called before Stage D/G to prevent system from being reset.

### C.3.1 Watchdog Timer Functions

#### C.3.1.1 EapiWDogGetCap()

Command Line:

```
EapiWDogGetCap(...)
    __OUTOPT uint32_t *pMaxDelay,
    __OUTOPT uint32_t *pMaxEventTimeout,
    __OUTOPT uint32_t *pMaxResetTimeout
)
```

Use this command to get maximum Supported Delay / Supported Event Timeout / Supported Reset Timeout of the watchdog timer.

Parameters	Function Parameters
*pMaxDelay	Maximum Supported Delay in milliseconds
*pMaxEvenTimeout	Maximum Supported Event Timeout in milliseconds; 0 = Unsupported
*pMaxResetTimeout	Maximum Supported Reset Timeout in milliseconds
Condition	Return Values
Library Uninitialized	EAPI_STATUS_NOT_INITIALIZED
pMaxDelay == NULL && pMaxResetTimeout == NULL && pMaxEventTimeout == NULL	EAPI_STATUS_INVALID_PARAMETER
Common Error	Common Error Code
Others	EAPI_STATUS_SUCCESS

### C.3.1.2 EapiWDogStart()

Command Line:

```
EApiWDogStart(  
    __IN uint32_t Delay,  
    __IN uint32_t Minute,  
    __IN uint32_t EventTimeout,  
    __IN uint32_t ResetTimeout  
)
```

Use this command to start the Watchdog Timer and set the timeout values.

To stop the Watchdog Timer, issue the command **EApiWDogStop**. After issuing EApiWDogStop, the command EApiWDogStart must be called again with new values to restart.

If the hardware implementation of the watchdog timer does not allow the user to select the exact time they want, the EAPI will select the next longer time setting available.

Parameters	Function Parameters
Delay	Delay in milliseconds
Minute	Control minutes or seconds
EventTimeout	Event Timeout in milliseconds
ResetTimeout	Reset Timeout in milliseconds
Condition	Return Values
Library Uninitialized	EAPI_STATUS_NOT_INITIALIZED
(Delay > gMaxDelay) (EventTimeout > gMaxEventTimeout) (ResetTimeout > gMaxResetTimeout)	EAPI_STATUS_INVALID_PARAMETER
Common Error	Common Error Code
Others	EAPI_STATUS_SUCCESS

### C.3.1.3 EapiWDogTrigger()

Command Line:

```
EapiWDogTrigger()
```

Use this command to trigger the Watchdog Timer.

Parameters	Function Parameters
None	
Condition	Return Values
Library Uninitialized	EAPI_STATUS_NOT_INITIALIZED
Watchdog Not Started	EAPI_STATUS_ERROR
Common Error	Common Error Code
Others	EAPI_STATUS_SUCCESS

### C.3.1.4 EapiWDogStop()

Command Line:

```
EapiWDogStop()
```

Use this command to close the Watchdog Instance. This will disable the Watchdog Timer and clear previous settings.

Parameters	Function Parameters
None	
Condition	Return Values
Library Uninitialized	EAPI_STATUS_NOT_INITIALIZED
Common Error	Common Error Code
Others	EAPI_STATUS_SUCCESS

### C.3.1.5 EapiWDogReloadTimer()

Command Line:

```
EapiWDogReloadTimer()
```

Use this command to reload the Timeout count

Parameters	Function Parameters
None	
Condition	Return Values
Library Uninitialized	EAPI_STATUS_NOT_INITIALIZED
Common Error	Common Error Code
Others	EAPI_STATUS_SUCCESS

### C.3.1.6 EapiWDogGetStatus()

Command Line:

```
EapiWDogGetStatus(
    __OUTOPT uint32_t *pwdtMinute,
    __OUTOPT uint32_t *pwdtCountTime,
    __OUTOPT uint32_t *pwdtReloadTime
)
```

Use this command to get the Watchdog Timer mode, time count value and reload timer.

Parameters	Function Parameters
*pwdtMinute	Get the mode of minute or second
*pwdtCountTime	Get WDT time count
*pwdtReloadTime	Get WDT ReloadTime
Condition	Return Values
Library Uninitialized	EAPI_STATUS_NOT_INITIALIZED
Common Error	Common Error Code
Others	EAPI_STATUS_SUCCESS

### C.3.1.7 EapiWDogSetStatus()

Command Line:

```
EApiWDogSetStatus(  
    __IN uint32_t wdtMinute,  
    __IN uint32_t wdtCountTime,  
    __IN uint32_t wdtReloadTime  
)
```

Use this command to set Watchdog Timer mode, time count value and reload timer.

Parameters	Function Parameters
wdtMinute	Set the mode of minute or second
wdtCountTime	Set WDT time count
wdtReloadTime	Set WDT ReloadTime
Condition	Return Values
Library Uninitialized	EAPI_STATUS_NOT_INITIALIZED
Common Error	Common Error Code
Others	EAPI_STATUS_SUCCESS