

MIX-H610A1

Industrial Motherboard

Copyright Notice

This document is copyrighted, 2023. All rights are reserved. The original manufacturer reserves the right to make improvements to the products described in this manual at any time without notice.

No part of this manual may be reproduced, copied, translated, or transmitted in any form or by any means without the prior written permission of the original manufacturer. Information provided in this manual is intended to be accurate and reliable. However, the original manufacturer assumes no responsibility for its use, or for any infringements upon the rights of third parties that may result from its use. The material in this document is for product information only and is subject to change without notice. While reasonable efforts have been made in the preparation of this document to assure its accuracy, the original manufacturer assumes no liabilities resulting from errors or omissions in this document, or from the use of the information contained herein.

The original manufacturer reserves the right to make changes in the product design without notice to its users.

Acknowledgments

All other products' name or trademarks are properties of their respective owners.

- AMI is a trademark of American Megatrends Inc.
- Intel®, Core™ are trademarks of Intel® Corporation.
- Microsoft Windows® is a registered trademark of Microsoft Corp.
- IBM, PC/AT, PS/2, and VGA are trademarks of International Business Machines Corporation.

The original manufacturer reserves the right to make changes in the product design without notice to its users.

All other product names or trademarks are properties of their respective owners.

Contents

Chapter 1	Product overview	
1.1	Package contents.....	1-1
1.2	Features	1-1
1.3	Specifications.....	1-2
Chapter 2	Motherboard information	
2.1	Before you proceed	2-1
2.2	Motherboard layout.....	2-2
2.3	Screw size.....	2-4
	2.3.1 Component side.....	2-4
	2.3.2 Solder side	2-5
2.4	Central Processing Unit (CPU)	2-6
	2.4.1 Installing the CPU	2-7
	2.4.2 CPU heatsink and fan assembly installation.....	2-9
2.5	System memory	2-11
	2.5.1 Installing a DIMM	2-12
2.6	Jumpers	2-13
2.7	Connectors	2-17
	2.7.1 Rear panel connectors.....	2-17
	2.7.2 Internal connectors	2-18
Chapter 3	BIOS setup	
3.1	BIOS setup program	3-1
	3.1.1 BIOS menu screen.....	3-2
	3.1.2 Menu bar	3-2
3.2	Main menu	3-2
	3.2.1 System Date [Day MM/DD/YYYY]	3-2
	3.2.2 System Time [HH:MM:SS].....	3-2
3.3	Advanced menu	3-3
	3.3.1 CPU Configuration	3-3
	3.3.2 Trusted Computing	3-3
	3.3.3 PTT Configuration.....	3-4
	3.3.4 SATA Configuration	3-5
	3.3.5 USB Configuration	3-5
	3.3.6 Hardware Monitor	3-5

Contents

- 3.3.7 SIO Configuration 3-8
- 3.3.8 PCH-FW Configuration 3-8
- 3.3.9 NVMe Configuration..... 3-9
- 3.3.10 Power Management..... 3-9
- 3.3.11 Digital IO Port Configuration 3-9
- 3.4 Chipset menu 3-10**
 - 3.4.1 System Agent (SA) Configuration 3-10
 - 3.4.2 PCH-IO Configuration 3-10
- 3.5 Security menu 3-11**
 - 3.5.1 Administrator Password 3-11
 - 3.5.2 User Password..... 3-11
 - 3.5.3 Secure Boot 3-12
- 3.6 Boot menu 3-13**
 - 3.6.1 Boot Configuration 3-13
 - 3.6.2 FIXED BOOT ORDER Priorities 3-13
- 3.7 Save & Exit menu 3-13**

Appendix

Notices.....A-1

Chapter 1

Product overview

1.1 Package contents

Check your industrial motherboard package for the following items.

- 1 x Industrial Motherboard
- 1 x SATA Cable
- 1 x I/O Shield



NOTE: If any of the above items is damaged or missing, contact your distributor or sales representative immediately.

1.2 Features

- Supports Intel® Alder Lake-S (ADL-S) / Raptor lake-S Core™ Processors, 8+8 cores, 65W
- Two DDR4 3200 MHz (max. 64GB) SODIMM
- SATA 6.0 Gb/s port x 2, M.2 2280 M-key x 1
- PCI-Express slot [x16] x 1, M.2 E-key (2232; PCIe x1 / CNVi / USB) x1;
- HDMI™, DisplayPort, LVDS, and eDP support

1.3 Specifications

SYSTEM	
Form factor	Mini ITX Form Factor, 6.7" x 6.7" (170 mm x 170 mm)
CPU	Intel® Alder Lake-S (ADL-S) / Raptor Lake – S (RPL-S) Processors, 8+8 cores, 65W
Memory	2 x SODIMMs, DDR4 (3200MHz, Max. 64GB) memory Dual-channel memory architecture
I/O Chipset	Intel® UHD Graphics
Ethernet	1 x Intel® PCIe Gb LAN i219V 3 x Realtek RTL8111H
BIOS	256Mbit Flash ROM, AMI BIOS
Wake on LAN/PXE	Yes (WOL/PXE)
Watchdog Timer	1~255 steps by software program
H/W Monitor	Temperature Monitor on CPU/CHASSIS Voltage Monitor on Vcore/5V/12V Fan Monitor on CPU/Chassis
Smart Fan Control	CPU Fan/Chassis Fan
Power State	S3, S4, S5
Expansion slot	1 x PCIe 3.0 [x16] slot 1 x M.2 E-key (2232; PCIe x1 / CNVi / USB)
TPM	TPM 2.0 IC on board
Battery	Lithium battery
Power requirement	ATX
Board size	6.7" x 6.7" (170 mm x 170 mm)
Weight	1.1 lb (0.5 Kg)
Operating temperature	32°F~140°F (0°C~60°C)
Storage temperature	-40°F ~185°F (-40°C ~85°C)
Operating humidity	0%~90% relative humidity, non-condensing
Power compliance	N/A
Certificate	CE/FCC Class A
GRAPHICS	
Graphics chipset	Intel® UHD Graphics
Graphics multi-display	HDMI x 2 + DP x 1, HDMI x 1+DP x 2 HDMI x 1 +DP x 1 + LVDS x 1, HDMI x 1+DP x 1 + eDP x 1,
HDMI™	HDMI™ 2.0; Up to 3840 x 2160 @ 60 Hz
DisplayPort	Up to 4096 x 2160 @ 60 Hz
LVDS	Up to 1920 x 1080 @60 Hz, Daul Channel 18/24 bit (via CH7513) co-layout with eDP (LVDS by default)
eDP	Up to 1920 x 1080 @ 60 Hz co-layout with LVDS

(continued on the next page)

Internal I/O	
Storage	2 x SATA (6.0Gb/s) ports 1 x M.2 M key (2280)
Serial port	1 x Boxer header for COM (RS-232/422/485) 1 x Boxer header for COM (RS-232)
USB	1 x USB 3.2 Gen 1 header (supports additional 2 USB3.2 Gen1 ports)
Display I/O	40-pin LVDS/eDP connector x 1 with Inverter (Default LVDS)
Fan	1 x CPU Fan header (4-pin) 1 x Chassis Fan header (4-pin)
Power	1 x 24-pin EATX Power connector 1 x 8-pin EATX 12V Power connector
DIO	1 x 8-bit Digital I/O interface (In/Out programmable)
Others	1 x Clear CMOS jumper 1 x Speaker header for 2W/4Ω 1 x Front Panel header 1 x Chassis Intrusion header 1 x AT/ATX mode selection jumper 1 x ME disable jumper 1 x eDP/LVDS Tcon IC voltage selection jumper 1 x Backlight voltage selection jumper
Audio	1 x AAFP follow ASUS pin out
Rear I/O	
USB	2 x USB 3.2 Gen 1 ports 4 x USB 2.0 ports
Display	2 x HDMI™ 2.0 ports 2 x DisplayPorts (V1.2)
Ethernet	4 x RJ45 ports
Audio	1 x Line-out jack 1 x Mic-in jack
Others	
OS Support	Windows® 11 64 bit, Windows® 10 64 bit



NOTE: Specifications are subject to change without notice.

Chapter 2

Motherboard information

2.1 Before you proceed

Take note of the following precautions before you install motherboard components or change any motherboard settings.



CAUTION!

- Unplug the power cord from the wall socket before touching any component.
 - Before handling components, use a grounded wrist strap or touch a safely grounded object or a metal object, such as the power supply case, to avoid damaging them due to static electricity.
 - Hold components by the edges to avoid touching the ICs on them.
 - Whenever you uninstall any component, place it on a grounded antistatic pad or in the bag that came with the component.
 - Before you install or remove any component, ensure that the ATX power supply is switched off or the power cord is detached from the power supply. Failure to do so may cause severe damage to the motherboard, peripherals, or components.
-

2.2 Motherboard layout



NOTE: Place four screws into the holes indicated by circles to secure the motherboard to the chassis.



CAUTION! Do not overtighten the screws! Doing so can damage the motherboard.

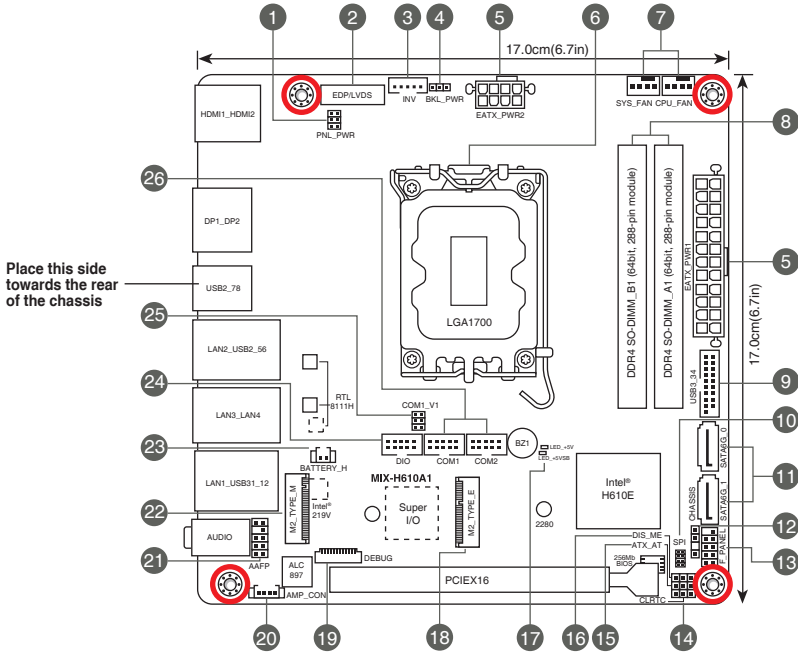

Connectors/Jumpers/Slots		Page
1.	LVDS T-con IC Power selection jumper (PNL_PWR)	2-16
2.	eDP/LVDS connector	2-26
3.	LVDS Panel Backlight Power header (INV)	2-25
4.	LVDS Panel Power selection jumper (3-pin BKL_PWR)	2-14
5.	ATX Power connectors (24-pin EATX_PWR1, 8-pin EATX_PWR2)	2-18
6.	Intel® LGA1700 CPU socket	2-6
7.	CPU and System Fan headers (4-pin CPU_FAN, 4-pin SYS_FAN)	2-19
8.	DDR4 SO-DIMM slots	2-11
9.	USB 3.2 Gen 1 header (USB3_34)	2-23
10.	BIOS Programmable header (8-pin SPI)	2-19
11.	Serial ATA 6.0Gb/s ports (7-pin SATA6G_0~1)	2-22
12.	Chassis Intrude header (4-1 pin CHASSIS)	2-15
13.	System Panel header (10-1 pin F_PANEL)	2-21
14.	Clear RTC RAM (CLRTC)	2-13
15.	AT/ATX mode selection jumper (3-pin ATX_AT)	2-14
16.	Intel® ME jumper (3-pin DIS_ME)	2-16
17.	Standby Power LEDs	2-27
18.	M.2 E-Key slot	2-27
19.	Debug Card connector	2-23
20.	Audio Amplifier connector (4-pin AMP_CON)	2-20
21.	Front Panel Audio header (AAFP)	2-22
22.	M.2 M-Key slot	2-26
23.	Battery connector (2-pin BATTERY_H)	2-20
24.	Digital I/O header (10-pin DIO)	2-25
25.	COM1 Ring/+5V/+12V selection header (COM1_V1)	2-15
26.	COM port headers (COM1/COM2)	2-24

2.3 Screw size

2.3.1 Component side

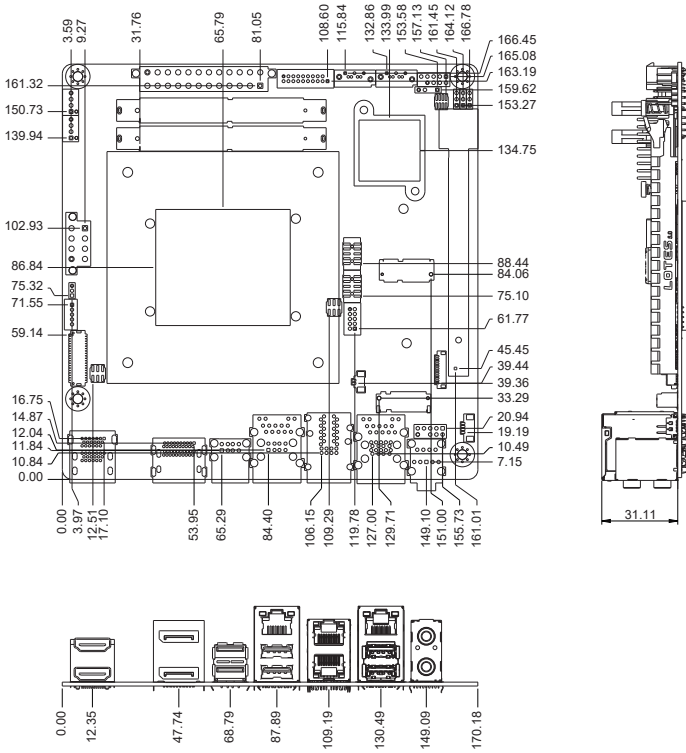

2.3.2 Solder side

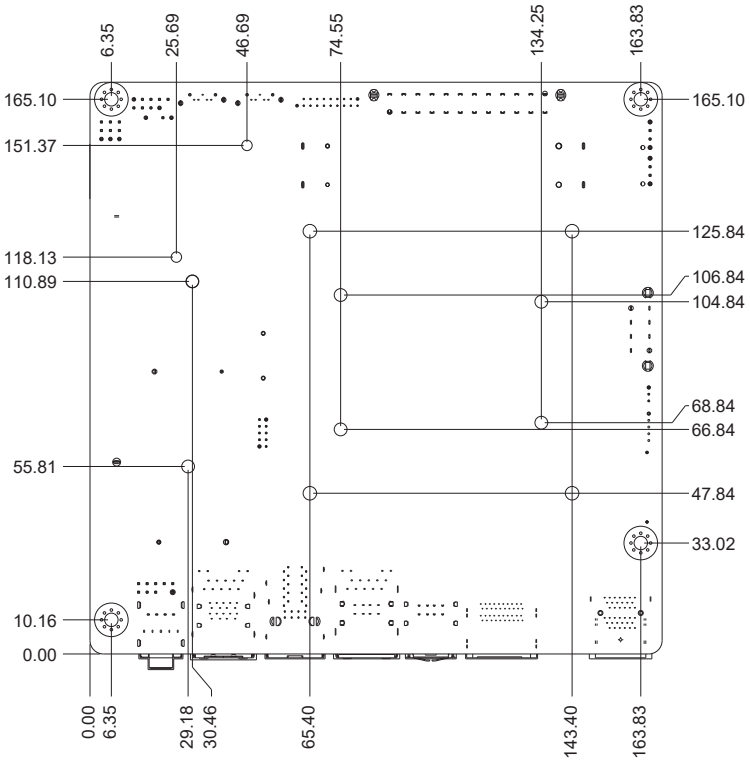

2.4 Central Processing Unit (CPU)

The motherboard comes with a surface mount LGA1700 socket designed for the Intel® Alder Lake-S (ADL-S) / Raptor Lake – S (RPL-S) Processors 8+8 cores, 65W.

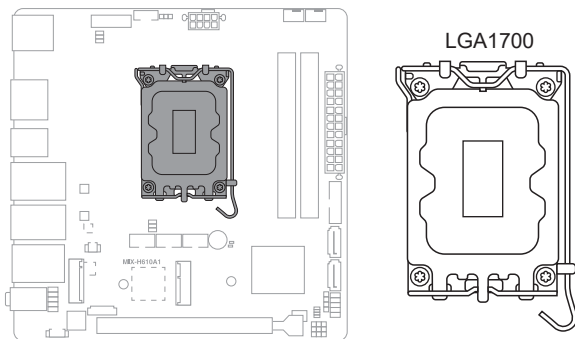

IMPORTANT: Unplug all power cables before installing the CPU.



CAUTION!

- Ensure that you install the correct CPU designed for LGA1700 socket only. DO NOT install a CPU designed for other sockets on the LGA1700 socket.
 - The CPU fits in only one correct orientation. DO NOT force the CPU into the socket to prevent bending the connectors on the socket and damaging the CPU.
 - Ensure that all power cables are unplugged before installing the CPU.
 - Upon purchase of the motherboard, ensure that the PnP cap is on the socket and the socket contacts are not bent. Contact your retailer immediately if the PnP cap is missing, or if you see any damage to the PnP cap/socket contacts/motherboard components. ASUS will shoulder the cost of repair only if the damage is shipment/transit-related.
 - Keep the cap after installing the motherboard. ASUS will process Return Merchandise Authorization (RMA) requests only if the motherboard comes with the cap on the LGA1700 socket.
 - The product warranty does not cover damage to the socket contacts resulting from incorrect CPU installation/removal, or misplacement/loss/incorrect removal of the PnP cap.
-

2.4.1 Installing the CPU



CAUTION!

- Ensure that you install the correct CPU designed for LGA1700 socket only. DO NOT install a CPU designed for LGA1155, LGA1156, LGA1151, and LGA1200 sockets on the LGA1700 socket.
- ASUS will not cover damages resulting from incorrect CPU installation/removal, incorrect CPU orientation/placement, or other damages resulting from negligence by the user.

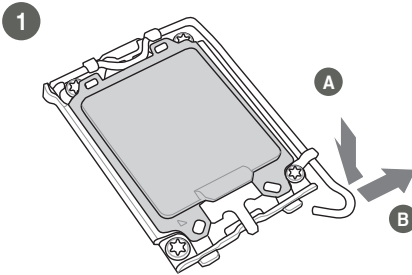
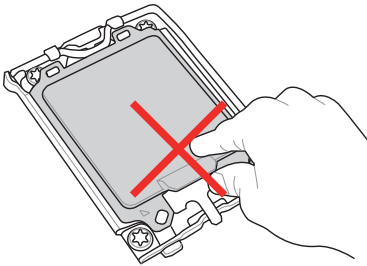

CAUTION! Take caution when lifting the load lever, ensure to hold onto the load lever when releasing the load lever. Letting go of the load lever immediately after releasing it may cause the load lever to spring back and cause damage to your motherboard.

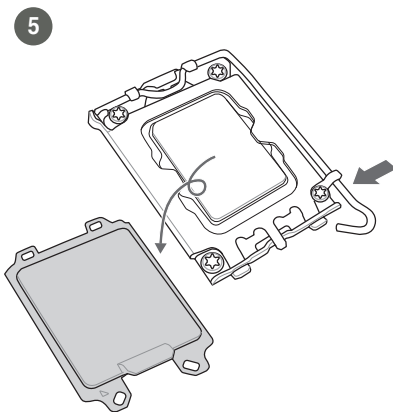
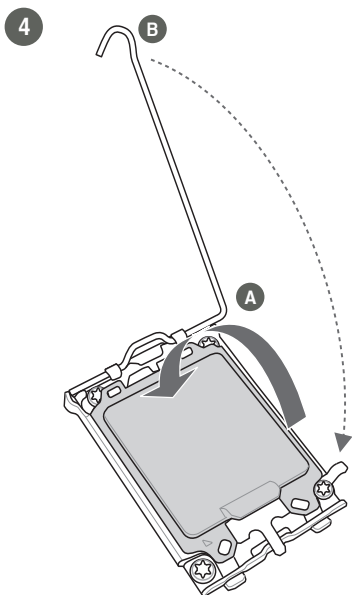
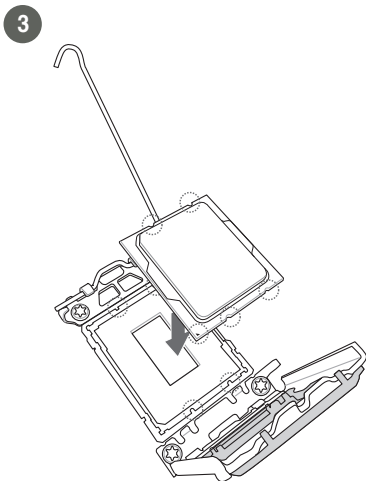
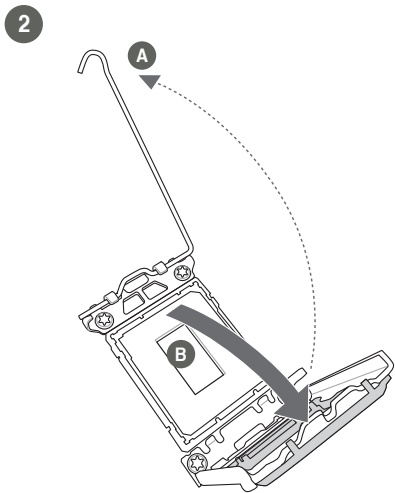

2.4.2 CPU heatsink and fan assembly installation

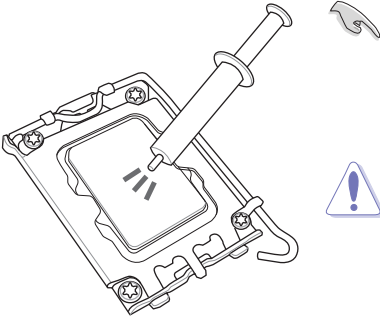

IMPORTANT: Apply Thermal Interface Material to the CPU cooling system and CPU before you install the cooling system, if necessary.

CAUTION! Ensure to remove the CPU Socket lever protector on the lever latch before installing the cooling system, failure to do so may cause damages to your system.

To install the CPU heatsink and fan assembly

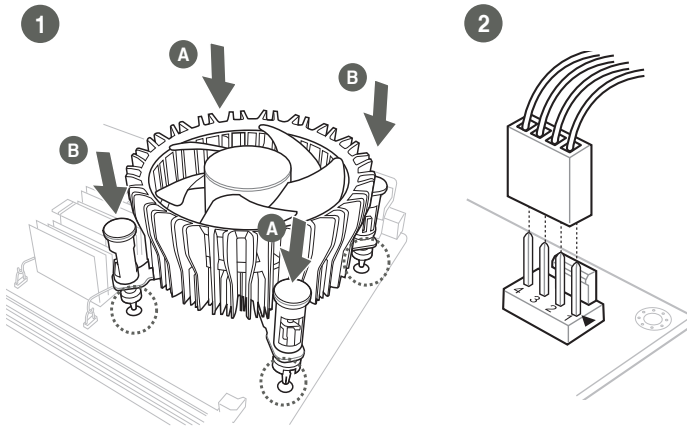

To uninstall the CPU heatsink and fan assembly

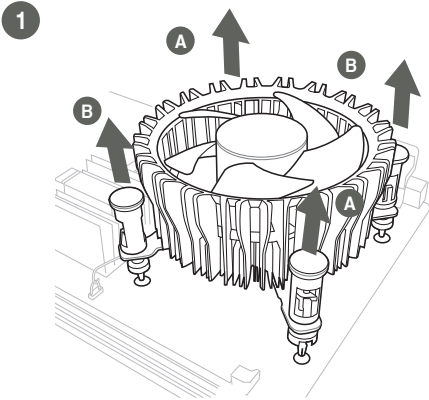

2.5 System memory

The motherboard comes with Small Outline Dual Inline Memory Modules (SO-DIMM) slots designed for DDR4 (Double Data Rate 4) memory modules.



CAUTION! A DDR5 memory module is notched differently from a DDR, DDR2, or DDR3 module. DO NOT install a DDR, DDR2, or DDR3 memory module to the DDR4 slot.

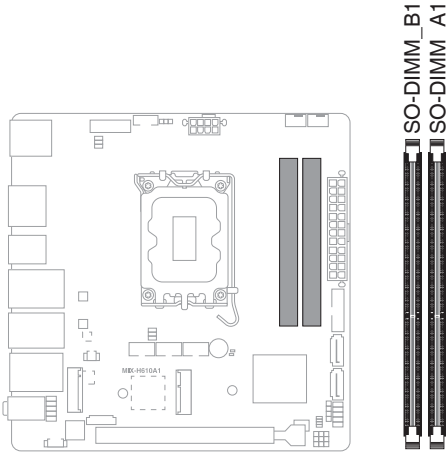

Recommended memory configurations

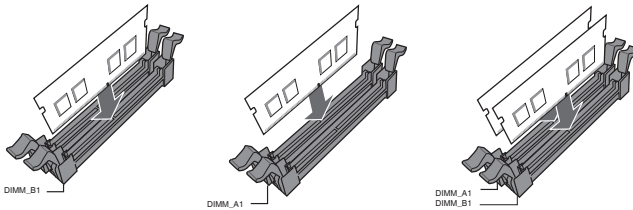

2.5.1 Installing a DIMM

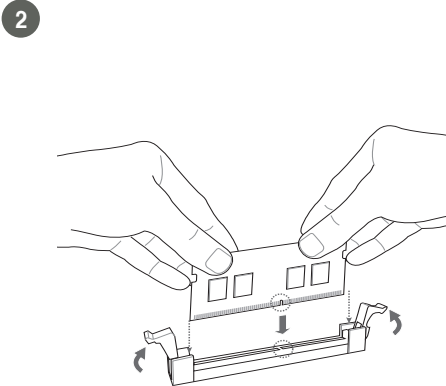
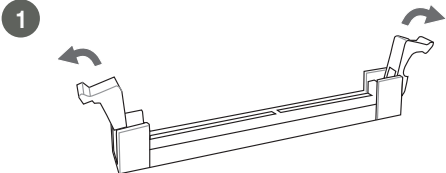

To remove a DIMM

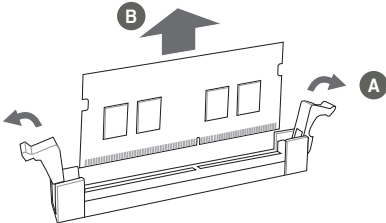

2.6 Jumpers

1. Clear RTC RAM (CLRRTC)

This jumper allows you to clear the Real Time Clock (RTC) RAM in CMOS. You can clear the CMOS memory of date, time, and system setup parameters by erasing the CMOS RTC RAM data. The onboard button cell battery powers the RAM data in CMOS, which include system setup information such as system passwords.

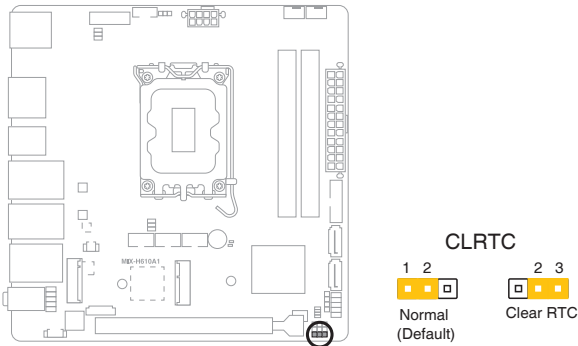

To erase the RTC RAM:

1. Turn OFF the computer and unplug the power cord.
2. Move the jumper cap from pins 1-2 (default) to pins 2-3. Keep the cap on pins 2-3 for about 5~10 seconds, then move the cap back to pins 1-2.
3. Plug the power cord and turn ON the computer.
4. Hold down the key during the boot process and enter BIOS setup to reenter data.



CAUTION! Except when clearing the RTC RAM, never remove the cap on CLRRTC jumper default position. Removing the cap will cause system boot failure!



NOTE: If the steps above do not help, remove the onboard battery and move the jumper cap again to clear the CMOS RTC RAM data. After clearing the CMOS, reinstall the battery.

2. LVDS Panel Power selection jumper (3-pin BKL_PWR)

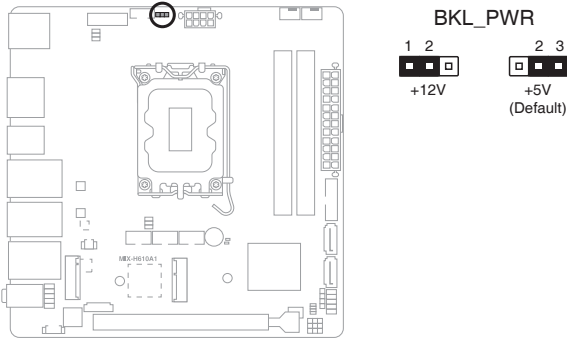

Setting	Pins
+12V	1-2
+5V	2-3 (Default)

3. AT/ATX Mode selection jumper (2-pin ATX_AT)

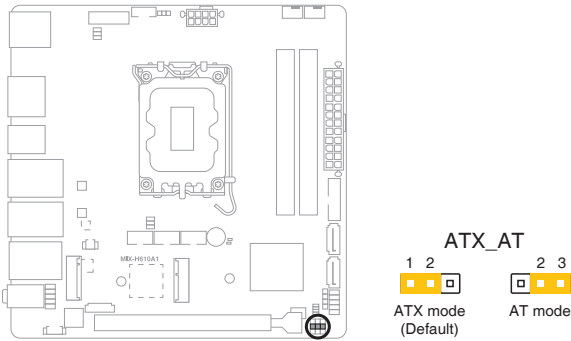

Pins	Description
1-2 (Default)	ATX mode
2-3	AT mode



NOTE: Jumper setting of **ATX_AT** should be consistent with the setting of **Power Mode** in BIOS. Refer to section **3.3.11 Power Management** in Chapter 3.

4. Chassis intrusion header (4-1 pin CHASSIS)

This header is for a chassis-mounted intrusion detection sensor or switch. Connect one end of the chassis intrusion sensor or switch cable to this header. The chassis intrusion sensor or switch sends a high-level signal to this header when a chassis component is removed or replaced. The signal is then generated as a chassis intrusion event.

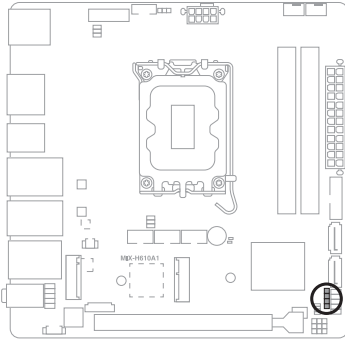

CHASSIS

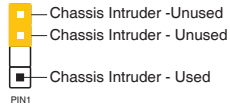

5. COM1 Ring/+5V/+12V selection jumper (6-pin COM1_V1)

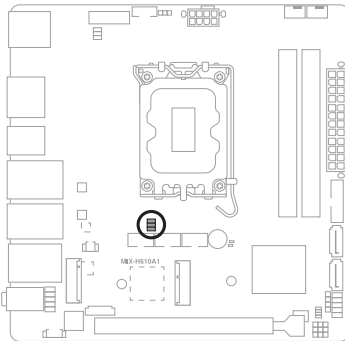

COM1_V1

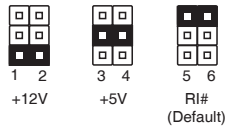

Setting	Pins
+12V	1-2
+5V	3-4
Ring	5-6 (Default)

6. Intel® ME Jumper (3-pin DIS_ME)

This jumper allows you to force the Intel® Management Engine (ME) to boot from recovery mode when ME becomes corrupted.

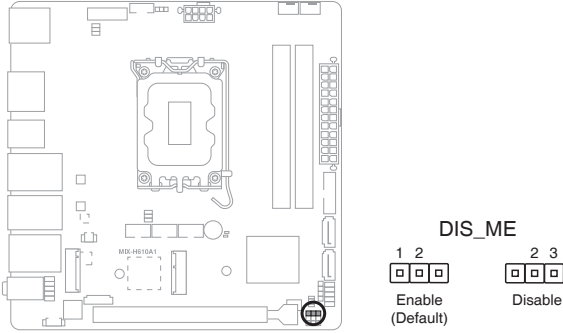

7. eDP/LVDS T-con IC Power jumper (6-pin PNL_PWR)

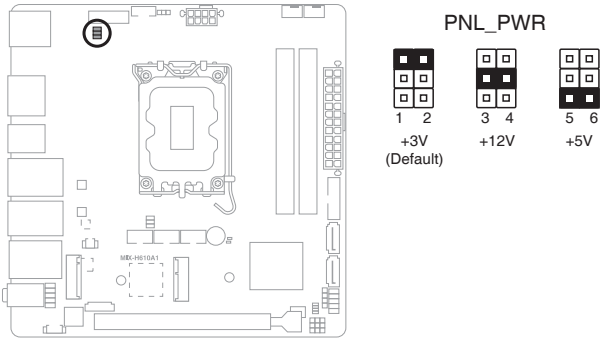

Setting	Pins
+3V	1-2 (Default)
+12V	3-4
+5V	5-6

2.7 Connectors

2.7.1 Rear panel connectors

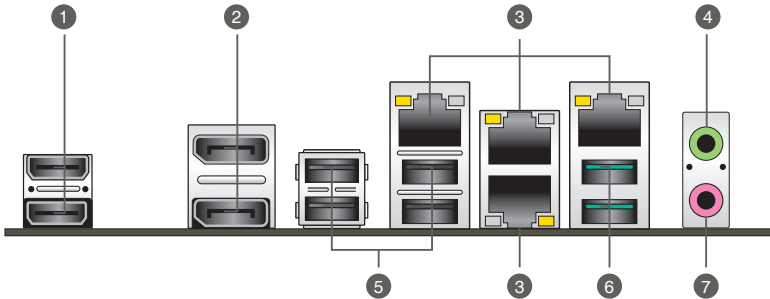

1. **HDMI™ ports.** These ports are for a High-Definition Multimedia Interface (HDMI™) connectors, and are HDCP compliant allowing playback of HD DVD, Blu-ray, and other protected content.
2. **DisplayPorts.** These ports are for DisplayPort-compatible devices.
3. **LAN (RJ-45) ports.** These ports allow Gigabit connection to a Local Area Network (LAN) through a network hub. Refer to the table below for the LAN port LED indications.

LAN port LED indications

ACT/LINK LED		SPEED LED	
Status	Description	Status	Description
OFF	No link	OFF	10 Mbps connection
YELLOW	Linked	ORANGE	100 Mbps connection
BLINKING	Data activity	GREEN	1 Gbps connection
YELLOW (Blinking then steady)	Ready to wake up from S5 mode		

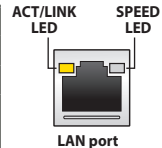

4. **Line Out port (lime).** This port connects to a headphone or a speaker. In a 4.1-channel and 5.1-channel configurations, the function of this port becomes Front Speaker Out.
5. **USB 2.0 ports.** These Universal Serial Bus (USB) ports are for USB 2.0 devices.
6. **USB 3.2 Gen 1 ports (Type-A).** These 9-pin Universal Serial Bus (USB) ports connect to USB 3.2 Gen 1 devices.



IMPORTANT: We strongly recommend that you connect your devices to ports with matching data transfer rate. For example connecting your USB 3.2 Gen 1 devices to USB 3.2 Gen 1 ports for faster and better performance for your devices.

7. **Microphone port (pink).** This port connects to a microphone.

2.7.2 Internal connectors

1. ATX Power connectors (24-pin EATX_PWR1, 8-pin EATX_PWR2)

These connectors are for ATX power supply plugs. The power supply plugs are designed to fit these connectors in only one orientation. Find the proper orientation and push down firmly until the connectors completely fit.

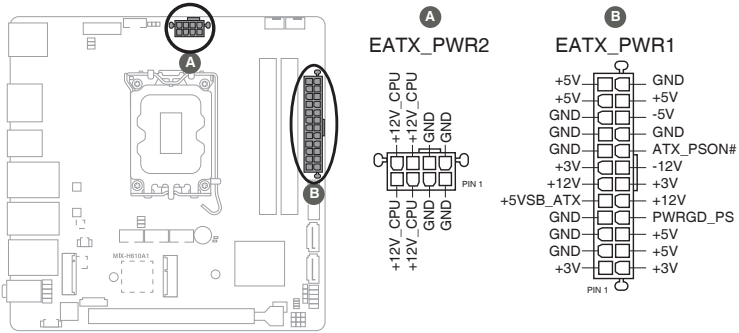

IMPORTANT:

- For a fully configured system, we recommend that you use a power supply unit (PSU) that complies with ATX 12 V Specification 2.0 (or later version) and provides a minimum power of 330W.
- We recommend that you use a PSU with higher power output when configuring a system with more power-consuming devices. The system may become unstable or may not boot up if the power is inadequate.

2. BIOS Programmable header (8-pin SPI_1)

Use this header to flash the BIOS ROM.

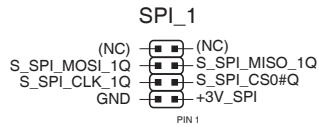
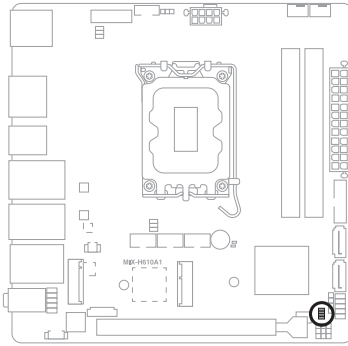

3. CPU and System Fan headers (4-pin CPU_FAN, 4-pin SYS_FAN)

Connect the fan cables to the fan headers on the motherboard, ensuring that the black wire of each cable matches the ground pin of the header.

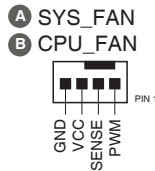
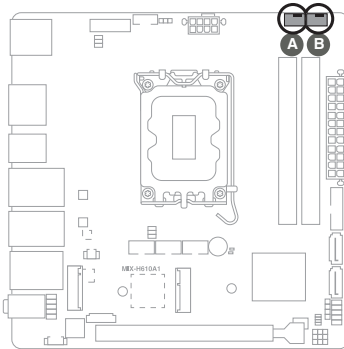

CAUTION! Do not forget to connect the fan cables to the fan headers. Insufficient air flow inside the system may damage the motherboard components. These are not jumpers! Do not place jumper caps on the fan headers!

4. Audio Amplifier connector (4-pin AMP_CON)

This connector is for an internal stereo amplifier speakers support (2W/4Ω via WtoB header).

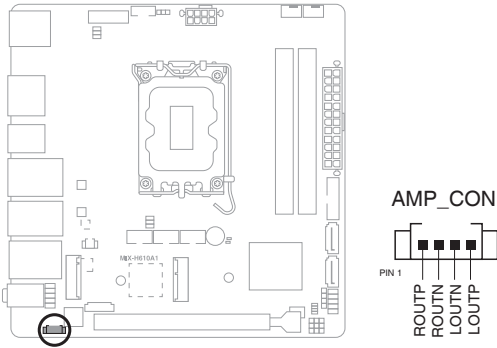

5. Battery connector (2-pin BATTERY_H)

This connector is for the lithium CMOS battery.

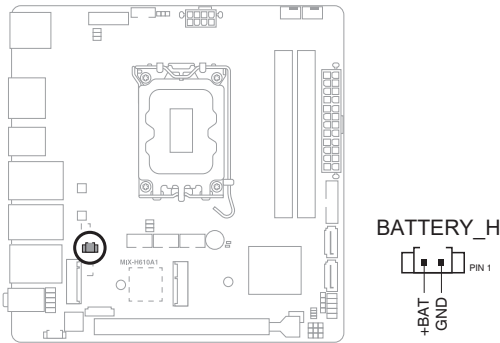

6. System Panel header (10-1 pin F_PANEL)

This header supports several chassis-mounted functions.

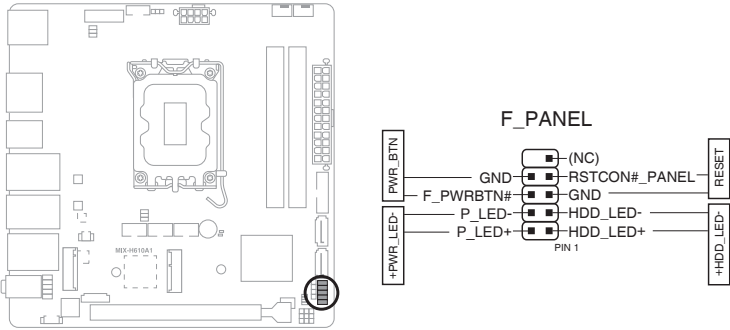

- **System Power LED header (2-pin +PWR_LED-)**

The 2-pin pin headers allow you to connect the System Power LED. The System Power LED lights up when the system is connected to a power source, or when you turn on the system power, and blinks when the system is in sleep mode.

- **Storage Device Activity LED header (2-pin +HDD_LED-)**

The 2-pin header allows you to connect the Storage Device Activity LED. The Storage Device Activity LED lights up or blinks when data is read from or written to the storage device or storage device add-on card.

- **Power Button/Soft-off Button header (2-pin PWR_BTN)**

The 2-pin header allows you to connect the system power button. Press the power button to power up the system, or put the system into sleep or soft-off mode (depending on the operating system settings).

- **Reset button header (2-pin RESET)**

The 2-pin header allows you to connect the chassis-mounted reset button. Press the reset button to reboot the system.

7. Serial ATA 6.0Gb/s ports (7-pin SATA6G_0~1)

These ports connect to Serial ATA 6.0 Gb/s hard disk drives via Serial ATA 6.0 Gb/s signal cables.

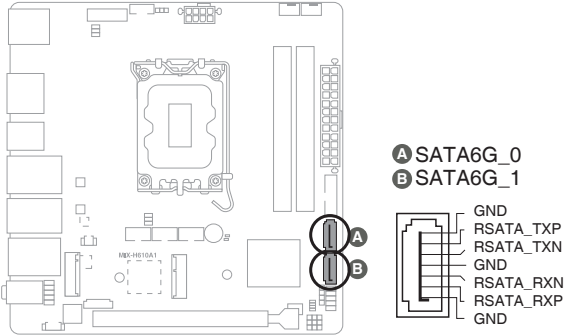

IMPORTANT: When using hot-plug and NCQ, set the SATA VMD controller item in the BIOS to [Disabled]. See section 3.3.4 **SATA Configuration** for details.

8. Front Panel Audio header (10-1 pin AAFP)

This header is for a chassis-mounted front panel audio I/O module that supports HD audio standard. Connect one end of the front panel audio I/O module cable to this header.

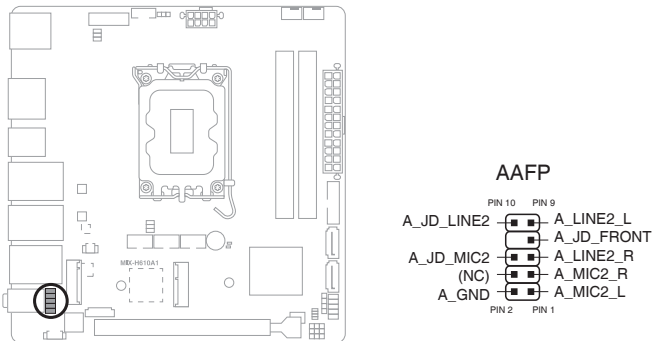

IMPORTANT: We recommend that you connect a high-definition front panel audio module to this header to avail of the motherboard's high-definition audio capability.

9. USB 3.2 Gen 1 header (20-pin USB3_34)

This header allows you to connect a USB 3.2 Gen 1 module for additional USB 3.2 Gen 1 front or rear panel ports. With an installed USB 3.2 Gen 1 module, you can enjoy all the benefits of USB 3.2 Gen 1 including faster data transfer speeds of up to 5 Gbps, faster charging time for USB-chargeable devices, optimized power efficiency, and backward compatibility with USB 2.0.

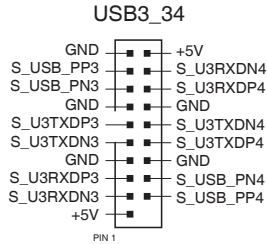
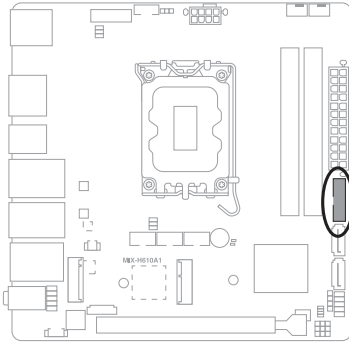

10. Debug Card connector (DEBUG)

This connector allows connection to a Debug card.

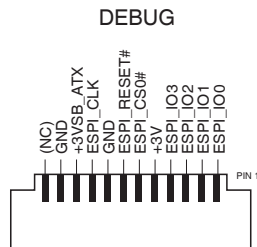
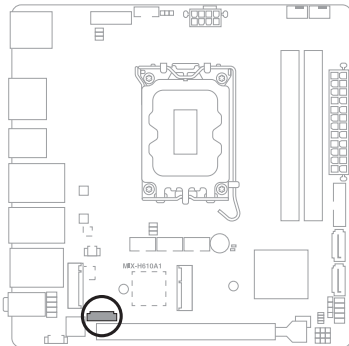

11. Serial Port headers (10-1 pin COM1~COM2)

These headers are for serial (COM) ports. Connect the serial port module cable to this header, then install the module to a slot opening at the back of the system chassis.

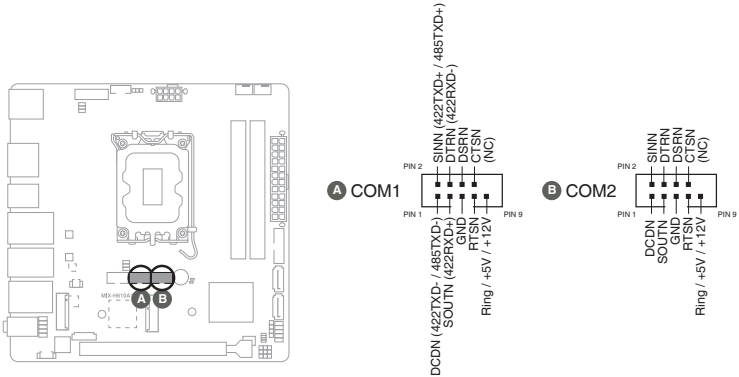

NOTES:

- The COM module is purchased separately.
- COM1 also supports RS-232 / RS-422 / RS-485. See the table below and section **3.3.7 SIO Configuration** for details.

Pin	Signal	Pin	Signal
1	DCDN (422TXD- / 485TXD-)	2	SINN (422TXD+ / 485TXD+)
3	SOUTN (422RXD+)	4	DTRN (422RXD-)
5	GND	6	DSRN
7	RTSN	8	CTSN
9	Ring / +5V / +12V	10	(NC)

12. Digital I/O header (10-pin DIO)

This header includes 8 I/O lines (In/Out programmable). All of the Digital I/O lines are programmable and each I/O pin can be individually programmed to support various devices.

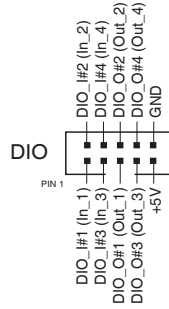
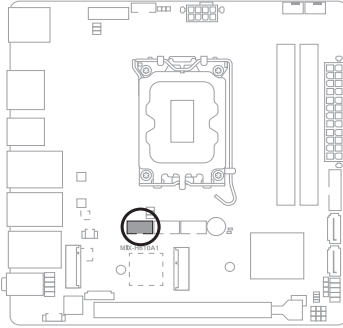

13. LVDS Panel Backlight Power header (5-pin INV)

Connect the backlight inverter power cable to this connector.

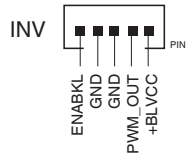
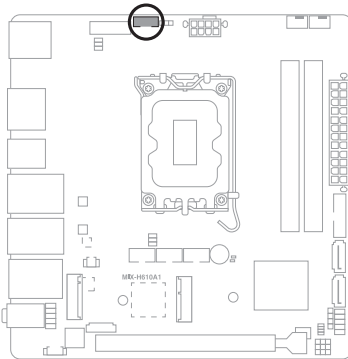

IMPORTANT: The backlight inverter power connector supports 1A current to the maximum.

14. eDP/LVDS connector

The connector is for an LCD monitor that supports Embedded DisplayPort (EDP) and Low Voltage Differential Signaling (LVDS) interfaces.

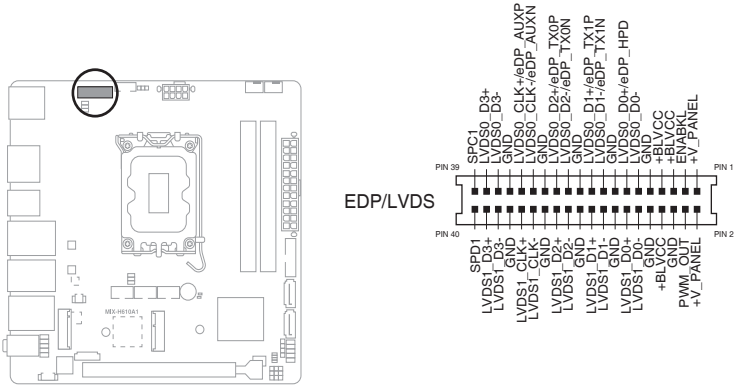

15. M.2 M-key slot

The M.2 M-key slot allows you to install an M.2 SSD module.

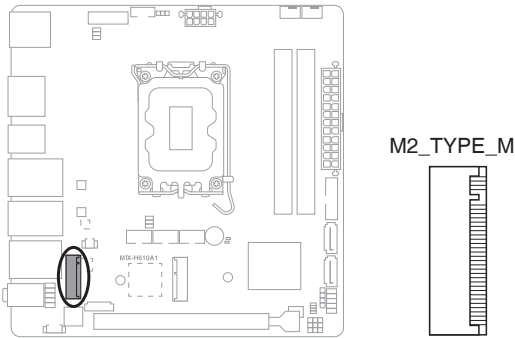

NOTES:

- The M.2 module is purchased separately.
- The M.2 M-key slot supports PCIe x4 mode design and type 2280 storage device.

16. M.2 E-Key slot

The M.2 E-key slot allows you to install an M.2 Wi-Fi module.

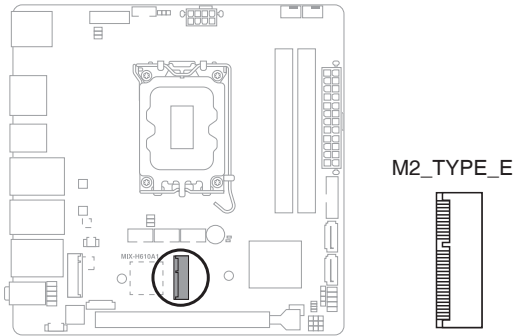

NOTES:

- The M.2 module is purchased separately.
- The M.2 E-key slot supports PCIe x1 / CNVi / USB device.

17. Standby Power LEDs (LED_5V/5VSB)

The motherboard comes with two standby power LEDs that light up to indicate that the system is ON, in sleep mode or in soft-off mode. This is a reminder that you should shut down the system and unplug the power cable before removing or plugging in any motherboard component. The illustration below shows the location of the onboard LEDs.

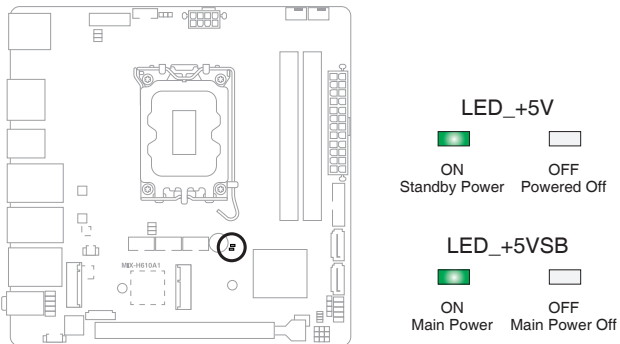

System state	LED indication
S0 state	LED_5V & LED_5VSB keep lighting
S5 state	Only LED_5VSB keep lighting

Chapter 3

BIOS setup

3.1 BIOS setup program

Use the BIOS Setup program to configure its parameters. The BIOS screens include navigation keys and brief online help to guide you in using the BIOS Setup program.

Entering BIOS Setup at startup

To enter BIOS Setup at startup:

Press <Delete> during the Power-On Self Test (POST). If you do not press <Delete>, POST continues with its routine.

Entering BIOS Setup after POST

To enter BIOS Setup after POST:

- Press <Ctrl>+<Alt>+ simultaneously.
- Press the reset button on the system chassis.
- Press the power button to turn the system off then back on. Do this option only if you failed to enter BIOS Setup using the first two options.



CAUTION! Using the power button, reset button, or the <Ctrl>+<Alt>+ keys to reboot a running operating system can cause damage to your data or system. Always shut down the system properly from the operating system.



IMPORTANT:

- The default BIOS settings for this motherboard apply to most working conditions and ensures optimal performance. If the system becomes unstable after changing any BIOS settings, load the default settings to regain system stability. Select the option **Restore Defaults** under the Save & Exit Menu. See section 3.7 **Save & Exit**.
 - The BIOS setup screens shown in this section are for reference purposes only, and may not exactly match what you see on your screen.
-

3.1.1 BIOS menu screen

3.1.2 Menu bar

The menu bar on top of the screen has the following main items:

Main	For changing the basic system configuration.
Advanced	For changing the advanced system settings.
Chipset	For viewing and changing chipset settings.
Security	For setting up BIOS security settings.
Boot	For changing the system boot configuration.
Save & Exit	For selecting the exit options and loading default settings.

To select an item on the menu bar, press the right or left arrow key on the keyboard until the desired item is highlighted.

3.2 Main menu

The Main menu provides you an overview of the basic system information, and allows you to set the system date, time, language, and security settings.

3.2.1 System Date [Day MM/DD/YYYY]

Allows you to set the system date.

3.2.2 System Time [HH:MM:SS]

Allows you to set the system time.

3.3 Advanced menu

The Advanced menu items allow you to change the settings for the CPU and other system devices.



CAUTION! Be cautious when changing the settings of the Advanced menu items. Incorrect field values can cause the system to malfunction.

Case Open Warning [Disabled]

Allows you to enable or disable the case open detecting function. Configuration options: [Disabled] [Enabled] [Clear]

3.3.1 CPU Configuration

The items in this menu show CPU-related information the BIOS automatically detects.



IMPORTANT: The items shown in the submenu may be different depending on the type of CPU installed.

Performance-core Information

The item displays the P-Core information.

Hyper-threading [Enabled]

The Intel Hyper-Threading Technology allows a hyper-threading processor to appear as two logical processors to the operating system, allowing the operating system to schedule two threads or processes simultaneously.

[Enabled]

Two threads per activated core are enabled.

[Disabled]

Only one thread per activated core is enabled.



IMPORTANT: Configuration options for active processor cores are dependent on the installed CPU.

Intel (VMX) Virtualization Technology [Enabled]

[Enabled]

Allows a hardware platform to run multiple operating systems separately and simultaneously, enabling one system to virtually function as several systems.

[Disabled]

Disables this function.

3.3.2 Trusted Computing

Security Device Support [Enable]

Allows you to enable or disable BIOS support for security devices. Configuration options: [Disable] [Enable]

SHA256 PCR Bank [Enabled]

Allows you to enable or disable SHA256 PCR Bank. Configuration options: [Disabled] [Enabled]

SHA384 PCR Bank [Disabled]

Allows you to enable or disable SHA384 PCR Bank. Configuration options: [Disabled] [Enabled]

Pending operation [None]

Allows you to schedule an operation for the Security Device. Configuration options: [None] [TPM Clear]



NOTE: The computer reboots during restart in order to change the state of the Security Device.

Platform Hierarchy [Enabled]

Allows you to enable or disable Platform Hierarchy. Configuration options: [Enabled] [Disabled]

Storage Hierarchy [Enabled]

Allows you to enable or disable Storage Hierarchy. Configuration options: [Enabled] [Disabled]

Endorsement Hierarchy [Enabled]

Allows you to enable or disable Endorsement Hierarchy. Configuration options: [Enabled] [Disabled]

Physical Presence Spec Version [1.3]

Selects to tell operating system to support PPI S pec Version 1.2 or 1.3. Some HCK tests might not support 1.3. Configuration options: [1.2] [1.3]

Device Select [Auto]

Allows you to select the TPM device. Configuration options: [Auto] [TPM1.2] [TPM2.0]

3.3.3 PTT Configuration

This item allows you to set the PTT configuration.

TPM Device Selection [dTPM]

Allows you to select TPM device.

[PTT] Enables PTT in SkuMgr.

[dTPM] Disables PTT in SkuMgr.



NOTE: When PTT is disabled, all data saved on it will be lost.

3.3.4 SATA Configuration

The BIOS automatically detects the presence of SATA devices. The Serial ATA Ports listed will display **Empty** if there are no Serial devices connected to the ports.

SATA Controller(s) [Enabled]

Allows you to enable or disable SATA devices.

Configuration options: [Enabled] [Disabled].



NOTE: The following items appear only when you set **SATA Controller(s)** to [Enabled].

SATA6G_0/1

Port 0/1 [Enabled]

Allows you to enable / disable the SATA port(s). Configuration options: [Disabled] [Enabled]

Hot Plug [Disabled]

Allows you to enable / disable the SATA Hot Plug Support. Configuration options: [Disabled] [Enabled]

3.3.5 USB Configuration



NOTE: The USB Devices item lists auto-detected values. If no USB device is detected, the item shows None.

USB Mass Storage Driver Support [Enabled]

Allows you to enable or disable USB Mass Storage Driver Support. Configuration options: [Disabled] [Enabled]

3.3.6 Hardware Monitor

The items in this menu allow you to configure the smart fan.

Smart Fan Function

System Smart Fan and CPU Smart Fan Setting

Fan Mode [Smart Fan IV]

Allows you to select the FAN mode. Configuration options: [Manual Mode] [Thermal Cruise] [Speed Cruise] [Smart Fan IV]



NOTE: The following item appears only when you set **Fan Mode** to [Manual Mode].

Manual PWM [128]

Allows you to set the Manual PWM value.



NOTE: The fan will work with this Manual PWM Value (0~255 for 10% ~100%).



NOTE: The following items appear only when you set **Fan Control Mode** to [Thermal Cruise Mode].

Critical temperature [60]

Input value range: [0~255]

Enable critical duty [Disabled]

Configuration options: [Disabled] [Enabled]

Critical duty value [10]

Input value range: [0~127]

Fan target temperature [40]

Input value range: [0~127]

Tolerance value [0]

Input value range: [0~7]

Stop duty [Disabled]

Configuration options: [Disabled] [Enabled]

Stop value [10]

Input value range: [0~127]

Startup value [1]

Input value range: [0~127]

Stop time [60]

Input value range: [0~127]



NOTE: The following items appear only when you set **Fan Mode** to [Speed Cruise].

Fan step up value [1]

Input value range: [0~15]

Fan step down value [1]

Input value range: [0~15]

Target speed count [2000]

Input value range: [0~4095]

Tolerance value [0]

Input value range: [0~63]



NOTE: The following items appear only when you set **Fan Mode** to [Smart Fan IV].

**Temperature 1 [25] / Temperature 2 [35] / Temperature 3 [45] /
Temperature 4 [55]**

Determines the temperature value for the Smart Fan IV mode.

Input value range: [0~255]

FD/RPM 1 [140] / FD/RPM 2 [170] / FD/RPM 3 [200] / FD/RPM 4 [230]

Determines the Fan Duty / RPM value.

Input value range: [0~255]

Critical temperature [60]

Input value range: [0~255]

Critical tolerance [0]

Input value range: [0~7]

Enable critical duty [Disabled]

Configuration options: [Disabled] [Enabled]

Tolerance value [0]

Input value range: [0~7]

RPM Mode [Disabled]

Allows you to enable or disable Smart Fan IV Close Loop Fan Control RPM Mode. Configuration options: [Disabled] [Enabled]

3.3.7 SIO Configuration

The items in this menu allow you to configure Super IO settings.

[*Active*] Serial Port 1

Use this device [Enabled]

Allows you to enable or disable this logical device. Configuration options: [Enabled] [Disabled]



NOTE: The following two items appear only when you set **Use this device** to [Enabled].

Possible [Use Automatic Settings]

Allows you to select an optimal setting for Super I/O devices. Configuration options: [Use Automatic Settings] [IO=3F8h; IRQ=4;] [IO=2F8h; IRQ=3]

Mode [RS232]

Allows you to select the Serial Port mode. Configuration options: [RS232] [RS422] [RS485]

[*Active*] Serial Port 2

Use this device [Enabled]

Allows you to enable or disable this logical device. Configuration options: [Enabled] [Disabled]

Possible [Use Automatic Settings]

This item appears only when you set **Use this device** to [Enabled] and allows you to select an optimal setting for Super I/O devices. Configuration options: [Use Automatic Settings] [IO=2F8h; IRQ=3] [IO=3F8h; IRQ=4;]

3.3.8 PCH-FW Configuration

The items listed in this screen display firmware related information.

Firmware Update Configuration

Me FW Image Re-Flash [Disabled]

Allows you to enable or disable Me firmware Image Re-Flash function. Configuration options: [Disabled] [Enabled]

FW Update [Disabled]

Allows you to enable or disable ME FW Update function. Configuration options: [Disabled] [Enabled]

3.3.9 NVMe Configuration

The NVMe Configuration menu displays the NVMe controller and drive information of the devices connected and allows you to configure NVMe device options settings.

3.3.10 Power Management

Power Mode [ATX Type]

Select power supply mode. Configuration options: [ATX Type] [AT Type]



NOTE: The following items appear when you set Power Mode to [ATX Type].

Restore AC Power Loss [Always Off]

[Last State] The system goes into either off or on state, whatever the system state was.

[Always On] The system goes into on state after an AC power loss.

[Always Off] The system goes into off state after an AC power loss.

RI Wake Event [Disabled]

Enable or disable system to wake up from RI#. Configuration options: [Enabled] [Disabled]

RTC Wake system from S5 [Disabled]

[Disabled] Disables system wake up from S5.

[Fixed Time] The system will wake up at the specified hr::min::sec.

[Dynamic Time] The system will wake up at the current time plus a specified

3.3.11 Digital IO Port Configuration

The items listed in this screen configure Digital IO settings.

DIO Port1~DIO Port4 [Output]

Configuration options: [Input] [Output]



NOTE: The following item appears only when you set **DIO Port1/2/3/4** to [Output].

Output Level [High]

Configuration options: [High] [Low]

DIO Port5~DIO Port8 [Input]

Configuration options: [Input] [Output]

3.4 Chipset menu

The Chipset menu items allow you to change the settings for the chipset.

3.4.1 System Agent (SA) Configuration

Primary Display [Auto]

Allows you to decide which graphics controller to use as the primary boot device. Configuration options: [Auto] [IGFX] [PEG Slot]

PCIEX16 Gen Speed [Auto]

Allows you to select the PCI Express port speed. Configuration options: [Auto] [Gen1] [Gen2] [Gen 3] [Gen 4] [Gen 5]

CH7513 [Disabled]

Configuration options: [Disabled] [eDP mode] [LVDS mode]



NOTE: The following items appear when you set **CH7513** to [LVDS mode].

LVDS Panel Type [1024x768, 18bit, 60Hz]

Select LCD panel used by Internal Graphics Device by selecting the appropriate setup item.

Configuration options: [640x480, 18bit, 60Hz] [800x480, 18bit, 60Hz] [800x600, 18bit, 60Hz] [1024x600, 18bit, 60Hz] [1024x768, 18bit, 60Hz] [1024x768, 24bit, 60Hz] [1280x768, 24bit, 60Hz] [1280x1024, 48bit, 60Hz] [1366x768, 24bit, 60Hz] [1440x900, 48bit, 60Hz] [1600x1200, 48bit, 60Hz] [1920x1080, 48bit, 60Hz] [1920x1200, 48bit, 60Hz] [1280x800, 24bit, 60Hz] [1280x800, 18bit, 60Hz]

LVDS Backlight Invert [Normal]

Configuration options: [Normal] [Invert]

LVDS Backlight Output Level [80%]

Configuration options: [0%] [10%] [20%] [30%] [40%] [50%] [60%] [70%] [80%] [90%]

3.4.2 PCH-IO Configuration

HD Audio [Enabled]

This item controls the detection of HD Audio devices. Configuration options: [Disabled] [Enabled]

3.5 Security menu

The Security menu items allow you to change the system security settings.

3.5.1 Administrator Password

If you have set an administrator password, we recommend that you enter the administrator password for accessing the system. Otherwise, you might be able to see or change only selected fields in the BIOS setup program.

To set an administrator password:

1. Select the **Administrator Password** item and press <Enter>.
2. From the **Create New Password** box, key in a password, then press <Enter>.
3. Confirm the password when prompted.

To change an administrator password:

1. Select the **Administrator Password** item and press <Enter>.
2. From the **Enter Current Password** box, key in the current password, then press <Enter>.
3. From the **Create New Password** box, key in a new password, then press <Enter>.
4. Confirm the password when prompted.

To clear the administrator password, follow the same steps as in changing an administrator password, but press <Enter> when prompted to create/confirm the password. After you clear the password, the **Administrator Password** item on top of the screen shows **Not Installed**.

3.5.2 User Password

If you have set a user password, you must enter the user password for accessing the system. The User Password item on top of the screen shows the default Not Installed. After you set a password, this item shows Installed.

To set a user password:

1. Select the **User Password** item and press <Enter>.
2. From the **Create New Password** box, key in a password, then press <Enter>.
3. Confirm the password when prompted. To change a user password:

To change a user password:

1. Select the **User Password** item and press <Enter>.
2. From the **Enter Current Password** box, key in the current password, then press <Enter>.
3. From the **Create New Password** box, key in a new password, then press <Enter>.
4. Confirm the password when prompted.

To clear the user password, follow the same steps as in changing a user password, but press <Enter> when prompted to create/confirm the password. After you clear the password, the **User Password** item on top of the screen shows **Not Installed**.

3.5.3 Secure Boot

Secure Boot feature is active when Secure Boot is set to [Enabled], Platform Key (PK) is enrolled and the system is running in User mode. Changing the mode requires platform reset. Configuration options: [Disabled] [Enabled]

Secure Boot Mode

Allows you to select Secure Boot Mode. When set to [Custom], Secure Boot Policy variables can be configured by a physically present user without full authentication. Configuration options: [Standard] [Custom]

Restore Factory Keys

Allows you to install factory default secure boot key databases.

Restore to Setup mode

Allows you to delete all secure boot key databases from NVRAM.

Key Management

Allows you to modify Secure Boot Policy variables without full authentication.

Factory Key Provision

Allows you to install factory default Secure Boot keys when the system is in Setup mode. Configuration options: [Enabled] [Disabled]

Restore Factory Keys

Configuration options: [Yes] [No]

Reset To Setup Mode

Configuration options: [Yes] [No]

Enroll Efi Image

Export Secure Boot variables

Platform Key (PK)

Configuration options: [Details] [Export] [Update] [Delete]

Key Exchange Keys / Authorized Signatures / Forbidden Signatures

Configuration options: [Details] [Export] [Update] [Append] [Delete]

Authorized TimeStamps / OsRecovery Signatures

Configuration options: [Update] [Append]

Export Secure Boot variables

Allows you to save NVRAM content of Secure boot variable to a file.

3.6 Boot menu

The Boot menu items allow you to change the system boot options.

3.6.1 Boot Configuration

Quiet Boot [Enabled]

This item enables/disables Quiet Boot. Configuration options: [Disabled] [Enabled]

Network Stack [Disabled]

This item allows user to disable or enable the UEFI network stack. Configuration options: [Disabled] [Enabled]

3.6.2 FIXED BOOT ORDER Priorities

Boot Option #1~#10

This item allows you to set the system boot order. Configuration options: [USB Key] [USB Hard Disk] [Hard Disk] [NVME] [Network] [USB Lan] [CD/DVD] [USB CD/DVD] [USB Floppy] [SD] [Disabled]

3.7 Save & Exit menu

Save Changes and Reset

Once you are finished making your selections, choose this option from the Save & Exit menu to ensure the values you selected are saved. When you select this option, a confirmation window appears. Select Yes to save changes and reset.

Discard Changes and Exit

This option allows you to exit the Setup program without saving your changes. When you select this option or if you press <Esc>, a confirmation window appears. Select Yes to discard changes and exit.

Restore Defaults

Save or restore User Defaults to all setup options.

Ruled lines for writing

Appendix

Notices

Federal Communications Commission Statement

This device complies with Part 15 of the FCC Rules. Operation is subject to the following two conditions:

- This device may not cause harmful interference.
- This device must accept any interference received including interference that may cause undesired operation.

This equipment has been tested and found to comply with the limits for a Class A digital device, pursuant to Part 15 of the FCC Rules. These limits are designed to provide reasonable protection against harmful interference in a residential installation. This equipment generates, uses and can radiate radio frequency energy and, if not installed and used in accordance with manufacturer's instructions, may cause harmful interference to radio communications. However, there is no guarantee that interference will not occur in a particular installation. If this equipment does cause harmful interference to radio or television reception, which can be determined by turning the equipment off and on, the user is encouraged to try to correct the interference by one or more of the following measures:

- Reorient or relocate the receiving antenna.
- Increase the separation between the equipment and receiver.
- Connect the equipment to an outlet on a circuit different from that to which the receiver is connected.
- Consult the dealer or an experienced radio/TV technician for help.



WARNING! The use of shielded cables for connection of the monitor to the graphics card is required to assure compliance with FCC regulations. Changes or modifications to this unit not expressly approved by the party responsible for compliance could void the user's authority to operate this equipment.



DO NOT throw the motherboard in municipal waste. This product has been designed to enable proper reuse of parts and recycling. This symbol of the crossed out wheeled bin indicates that the product (electrical and electronic equipment) should not be placed in municipal waste. Check local regulations for disposal of electronic products.



DO NOT throw the mercury-containing button cell battery in municipal waste. This symbol of the crossed out wheeled bin indicates that the battery should not be placed in municipal waste.



電子信息產品污染控制標示：圖中之數字為產品之環保使用期限。僅指電子信息產品中含有的有毒有害物質或元素不致發生外洩或突變從而對環境造成污染或對人身、財產造成嚴重損害的期限。

有毒有害物質或元素的名稱及含量說明標示：

部件名稱	有害物質或元素					
	鉛 (Pb)	汞 (Hg)	鎘 (Cd)	六 價 鉻 (Cr(VI))	多 溴 聯 苯 (PBB)	多 溴 二 苯 醚 (PBDE)
印刷電路板及其電子組件	×	○	○	○	○	○
外部信號連接頭及線材	×	○	○	○	○	○

○：表示該有毒有害物質在該部件所有均質材料中的含量均在 SJ/T 11363-2006 標準規定的限量要求以下。

×

×：表示該有毒有害物質至少在該部件的某一均質材料中的含量超出 SJ/T 11363-2006 標準規定的限量要求，然該部件仍符合歐盟指令 2002/95/EC 的規範。

備註：此產品所標示之環保使用期限，係指在一般正常使用狀況下。