

Industrial Motherboard

MAX-Q870A

HDMI[™]
HIGH-DEFINITION MULTIMEDIA INTERFACE

Copyright Notice

This document is copyrighted, 2026. All rights are reserved. The original manufacturer reserves the right to make improvements to the products described in this manual at any time without notice.

No part of this manual may be reproduced, copied, translated, or transmitted in any form or by any means without the prior written permission of the original manufacturer. Information provided in this manual is intended to be accurate and reliable. However, the original manufacturer assumes no responsibility for its use, or for any infringements upon the rights of third parties that may result from its use. The material in this document is for product information only and is subject to change without notice. While reasonable efforts have been made in the preparation of this document to assure its accuracy, the original manufacturer assumes no liabilities resulting from errors or omissions in this document, or from the use of the information contained herein.

The original manufacturer reserves the right to make changes in the product design without notice to its users.

Acknowledgments

All other products' name or trademarks are properties of their respective owners. AMI is a trademark of American Megatrends Inc.

- Intel® is a registered trademark of Intel® Corporation
- Core™ Ultra is a trademark of Intel® Corporation.
- Microsoft Windows® is a registered trademark of Microsoft Corp.
- IBM, PC/AT, PS/2, and VGA are trademarks of International Business Machines Corporation.
- Linux® is the registered trademark of Linus Torvalds in the U.S. and other countries.

The original manufacturer reserves the right to make changes in the product design without notice to its users.

All other product names or trademarks are properties of their respective owners.

Contents

CHAPTER 1		1
1.1.	Package contents	1
1.2.	Features	1
1.3.	Specifications	2
CHAPTER 2		6
2.1.	Before you Proceed	6
2.2.	Motherboard Layout	7
2.3.	Central Processing Unit (CPU)	9
2.3.1	Installing the CPU	10
2.3.2	CPU Heatsink and Fan Assembly Installation	12
2.3.3	System Memory	13
2.3.4	DIMM Installation	14
2.4.	Jumpers	15
2.4.1	COM1 Header Pin-9 Function Select (JP2)	16
2.4.2	COM 2 Header Pin-9 Function Select (JP3)	16
2.4.3	GPIO/80 Port Function Select (JP4)	17
2.4.4	Inverter VCC 5V/12V Function Select (JP11)	17
2.4.5	LVDS PVCC 3.3V/5V/12V Function Select (JP12)	18
2.4.6	ATX Mode/AT Mode Select (JAT_ATX)	19
2.4.7	Clear CMOS Function Select (JBAT1)	19
2.4.8	Case Open Function Select (JCOPEN1)	19
2.5.	Internal Connectors	21
2.5.1	Serial Port (RS-232/422/485) Connector (COM1)	23
2.5.2	Display Port Connector (DP1)	24
2.5.3	Dual HDMI Connector (HDMI1-HDMI2)	25
2.5.4	RJ-45 2.5GbE LAN Port Connector (UL1)	25
2.5.5	USB 3.2 Gen 2 Port Connector (UL1)	26
2.5.6	RJ-45 2.5GbE LAN Port Connector (UL2)	27
2.5.7	USB 3.2 Gen 2 Port Connector (UL2)	28
2.5.8	RJ-45 2.5GbE LAN Port Connector (UL3)	28
2.5.9	USB 3.2 Gen 2 Port Connector (UL3)	29
2.5.10	Audio Line In/Line Out/Mic Connector (AUDIO1)	30
2.5.11	Front Panel Audio Header (FP_AUDIO1)	30
2.5.12	3W Amplifier Wafer (SPEAK_CON1)	31
2.5.13	RS-232 Serial Port Header (COM 2/3/4/5/6)	31
2.5.14	RS-232 Serial Port Header (COM7-10)	32
2.5.15	GPIO Port Header (GPIO1)	33
2.5.16	SATA Port Connector (SATA 1/2)	34
2.5.17	Front Panel Header (FP)	35

2.5.18	CPU Fan Connector (CPUFAN1)	35
2.5.19	System Fan Connector (SYSFAN1/2)	36
2.5.20	PS/2 Keyboard and Mouse Header (PS2KBMS1)	36
2.5.21	SMBus Header (SMBUS1)	37
2.5.22	I2C Header (I2C1)	37
2.5.23	USB 2.0 Port Header (FP_USB 2/3/4)	38
2.5.24	LVDS/eDP Header (LVDS_EDP1)	38
2.5.25	LVDS_eDP Inverter Wafer (INVERTER1)	39
2.5.26	USB 3.2 Gen 1 Port Header (FP_USB1)	40
2.5.27	M.2 2242/2260/2280/22110 M-Key Slot (M2M1)	40
2.5.28	M.2 2242/2280 M-Key Slot (M2M2)	41
2.5.29	M.2 2230 E-Key Slot (M2E1)	41
2.5.30	M.2 2242/3052 B-Key Slot (M2B1)	42
2.5.31	Nano SIM Card Slot (SIMCARDB1)	42
2.5.32	24-pin ATX Power Supply Connector (ATXPWR1)	43
2.5.33	8-pin ATX 12V Power Connector (ATX12V1)	44
2.5.34	DDR5 U-DIMM Socket (DDR5_A1/A2/B1/B2)	44
2.5.35	PCIe Gen 5 [x16] Slot (PCIE1)	45
2.5.36	PCIe Gen 4 [x1] Slot (PCIE2)	46
2.5.37	PCIe Gen 4 [x4] Slot (PCIE3/4)	46
2.6.	Maximum Voltage & Current Limits	47

CHAPTER 3

3.1	BIOS Setup Program	48
3.2	BIOS Menu Screen	49
3.3	Setup Submenu: Main Menu	50
3.4	Setup Submenu: Advanced	51
3.4.1	CPU Configuration	52
3.4.2	Power & Performance	56
3.4.3	PCH-FW Configuration	61
3.4.4	Trusted Computing	62
3.4.5	ACPI Settings	63
3.4.6	Wake-up Function Settings	64
3.4.7	Super IO Configuration	66
3.4.8	PC Health Status	73
3.4.9	Serial Port Console Redirection	75
3.4.10	USB Configuration	81
3.4.11	Network Stack Configuration	82
3.4.12	NVMe Configuration	84
3.5	Setup Submenu: Chipset	87
3.5.1	System Agent (SA) Configuration	88
3.5.2	Graphics Configuration	89
3.5.3	VMD Setup Menu	91

3.5.4	PCH-IO Configuration	93
3.6	Setup Submenu: Security	95
3.6.1	Secure Boot	97
3.6.2	Key Management	98
3.7	Setup Submenu: Boot	109
3.7.1	BBS Priorities	110
3.8	Setup Submenu: Save & Exit	111
APPENDIX		112
FCC Statement		112
China RoHS Requirements (CN)		113
China RoHS Requirements (EN)		114

Chapter 1

Product Overview

1.1. Package contents

Check your industrial motherboard package for the following items:

- ☑ 1 x MAX-Q870A Motherboard
- ☑ 3 x COM Cables
- ☑ 2 x SATA Cables
- ☑ 1 x IO Shield
- ☑ 2 x Jumpers



If any of the above items is damaged or missing, contact your distributor or sales representative immediately

1.2. Features

- ☑ Intel® Core™ Ultra 200S Series LGA 1851 Socket Processors, up to 125W
- ☑ DDR5 6400MT/s Dual Channel CU/U-DIMM x 4, up to 256GB
- ☑ M.2 M-Key x 2, M.2 E-Key x 1, M.2 B-Key x 1
- ☑ USB 3.2 x 8, USB 2.0 x 6
- ☑ 2.5GbE LAN x 3
- ☑ PCIe Gen 5 [x16] x 1, PCIe Gen 4 [x4] x 2, PCIe Gen 4 [x 1] x 1
- ☑ SATA 6Gb/s x 2 with RAID 0, 1, 5
- ☑ ATX Power

1.3. Specifications

System	
Processor	Intel® Core™ Ultra 200S Series LGA 1851 Socket Processors, up to 125W
Chipset	Intel® Q870 Chipset
Memory	DDR5 6400MT/s x 4, Dual Channel CU/U-DIMM, up to 256GB
I/O Chipset	SIO: Fintek F81966
Ethernet	Intel® Ethernet Controller I226-LM, 2.5GbE x 1 Intel® Ethernet Controller I226-V, 2.5GbE x 1 Realtek® RTL8156, 2.5GbE x 1
Audio	Realtek® ALC897 with AMP (3W)
TPM	Intel® PTT (fTPM)
Expansion	PCIe Gen 5 [x16] x 1 PCIe Gen 4 [x4] x 2 PCIe Gen 4 [x1] x 1 M.2 2230 E-Key x 1 (PCIe Gen 4 [x1]/USB 2.0), CNVi supported M.2 3042/3052 B-Key x 1 (USB 3.2/USB 2.0), 4G/5G supported
BIOS	UEFI
H/W Monitor	TBD
WatchDog Timer	255 Levels
Smart Fan Control	CPU Fan/System Fan
Wake On LAN/ PXE	Yes (WOL)
Power State	S3, S5
Graphics	
Graphics Chipset	Intel® Graphics

Graphics Multi-Display	Supports 4 Displays
VGA	—
DVI	—
HDMI	HDMI 2.1 TMDS x 2 (Max Resolution: 4096 x 2160 @60Hz)
Display Port	DP 1.4a x 1 (Max Resolution: 4096 x 2160 @60Hz)
LVDS	24-bit Dual-Channel LVDS x 1 (Max. Resolution: 1920 x 1200 @60Hz, co-layout eDP)
eDP	Co-lay LVDS
Backlight Control	Yes
Environmental	
Battery	Lithium Battery
Power Requirement	ATX Power Supply, Internal 24+8-pin ATX Header
Operating Temperature	-4°F – 140°F (-20°C – 60°C) (Operational humidity: 10% – 90% Relative Humidity, Non-condensing)
Storage Temperature	-4°F – 185°F (-20°C – 85°C)
Certificate	CE & FCC Class A, LVD
Form Factor	Micro-ATX: 9.6" x 9.6" (244mm x 244mm)
Weight	TBD
MTBF (Hours)	TBD
Rear I/O Ports	
USB	USB 3.2 (Gen 2) x 6
Display I/O	HDMI 2.1 TMDS x 2, DP 1.4a x 1
Audio I/O	Mic-in x 1, Line-out x 1, Line-in x 1
LAN I/O	RJ-45 LAN Port x 3
Serial Port	DB-9 for RS-232/422/485 x 1
PS/2 Port	—
Others	—

Internal I/O Connectors	
Storage	SATA 6Gb/s x 2, RAID 0, 1, 5 supported M.2 2242/2280 M-Key x 1 (SATA/PCIe Gen 4 [x4]), NVMe supported M.2 2242/2260/2280/22110 M-Key x 1 (PCIe Gen 4 [x4]), NVMe supported
USB	USB 2.0 x 6 via Pin Header x 3 USB 3.2 (Gen 1x1) x 2 via Box Header x 1
Display I/O	LVDS/eDP connector x 1
Audio I/O	Speaker Header x 1 Front Panel x 1
Serial Port	Internal Header for DB-9 x 5 (RS-232) Internal RS-232 Header x 4 (Optional)
PS/2 Port	—
Parallel Port	—
DIO	8-bit DIO Header x 1
FAN	CPU Fan Header x 1 System Fan Header x 2
Power	24+8-pin ATX Header
Others	Nano SIM Card Slot x 1 Chassis Intrusion x 1 AT/ATX Mode Selection x 1
OS	
OS Support	Windows® 11 (64-bit) Linux

Chapter 2

Motherboard Information

2.1. Before you Proceed

Take note of the following precautions before you install motherboard components or change any motherboard settings.



CAUTION!

- Unplug the power cord from the wall socket before touching any component.
 - Before handling components, use a grounded wrist strap or touch a safely grounded object or a metal object, such as the power supply case, to avoid damaging them due to static electricity.
 - Hold components by the edges to avoid touching the ICs on them.
 - Whenever you uninstall any component, place it on a grounded antistatic pad or in the bag that came with the component.
 - Before you install or remove any component, ensure that the ATX power supply is switched off or the power cord is detached from the power supply. Failure to do so may cause severe damage to the motherboard, peripherals, or components.
-

2.2. Motherboard Layout



Place four screws into the holes indicated by circles to secure the motherboard to the chassis



Do not overtighten the screws! Doing so can damage the motherboard

Component Side

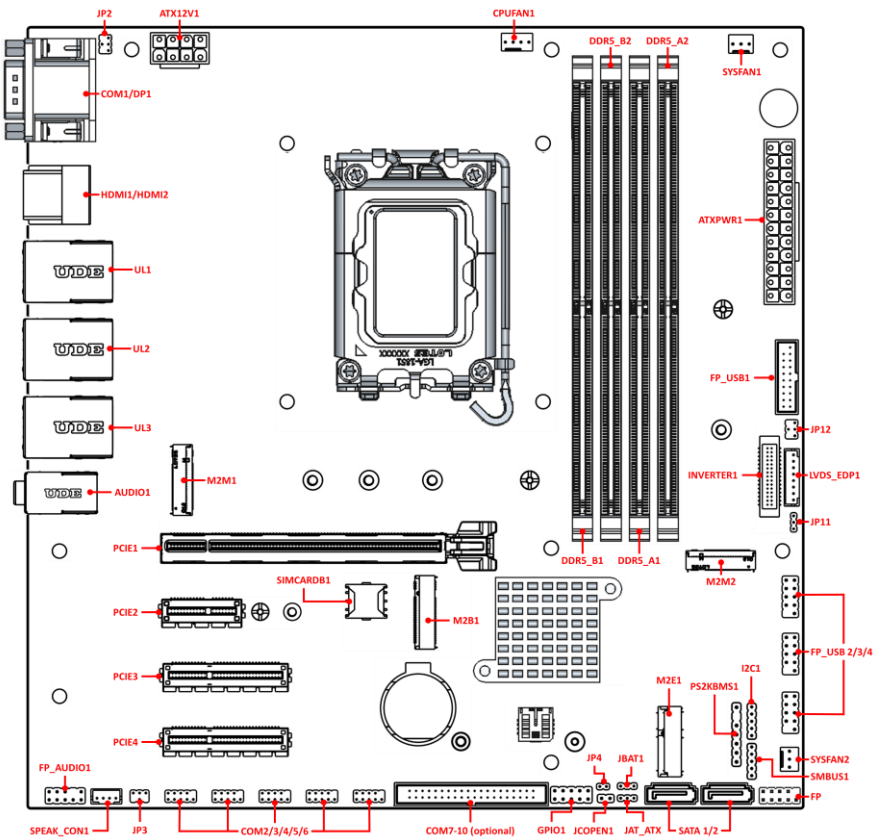

Screw Size

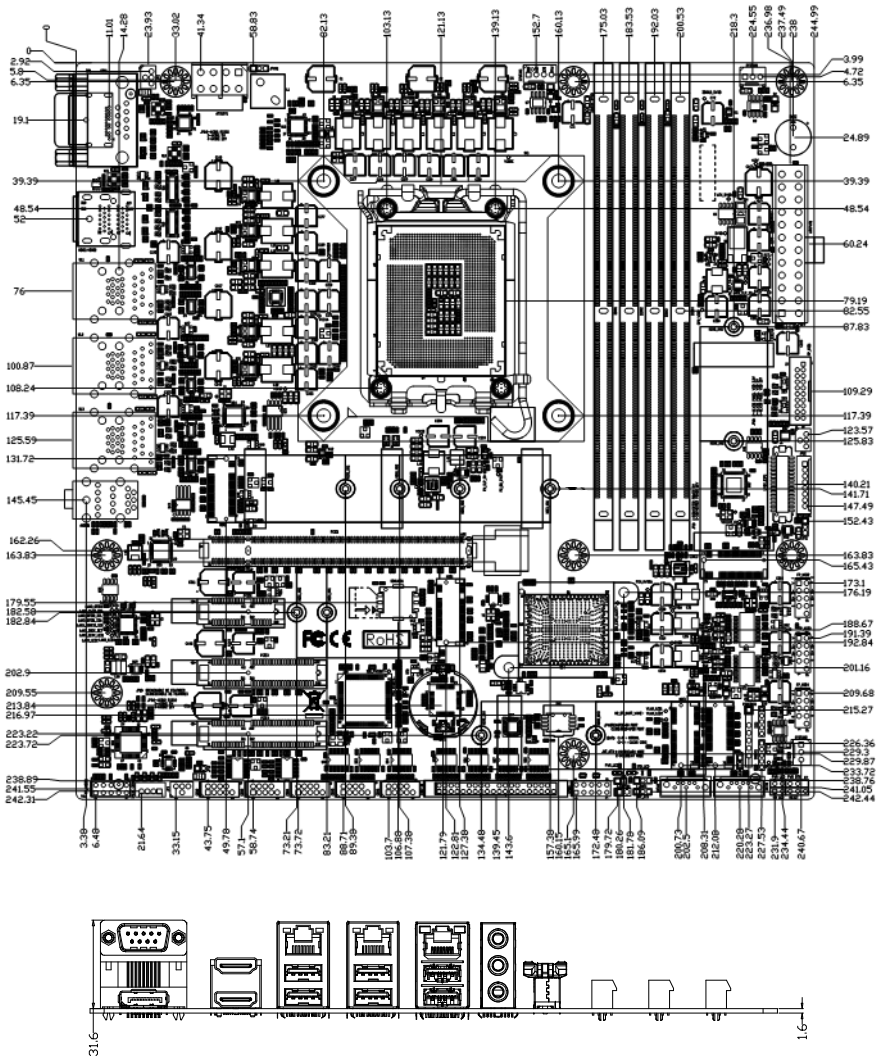

2.3. Central Processing Unit (CPU)

The motherboard comes with a surface mount LGA 1851 socket designed for Intel® Core™ Ultra Processors (Series 2) (formerly Arrow Lake-S).

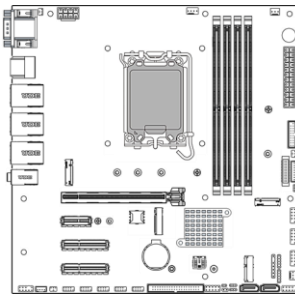

IMPORTANT: Unplug all power cables before installing the CPU.



CAUTION!

- Ensure that you install the correct CPU designed for LGA1851 socket only. DO NOT install a CPU designed for other sockets on the LGA1851 socket.
- The CPU fits in only one correct orientation. DO NOT force the CPU into the socket to prevent bending the connectors on the socket and damaging the CPU.
- Ensure that all power cables are unplugged before installing the CPU.
- Ensure that the PnP cap is on the socket and the socket contacts are not bent. Contact your retailer immediately if the PnP cap is missing, or if you see any damage to the PnP cap/socket contacts/motherboard components. ASUS will shoulder the cost of repair only if the damage is shipment/transit-related.
- Keep the cap after installing the motherboard. ASUS will process Return Merchandise Authorization (RMA) requests only if the motherboard comes with the cap on the LGA1851 socket.
- The product warranty does not cover damage to the socket contacts resulting from incorrect CPU installation/removal, or misplacement/loss/incorrect removal of the PnP cap.

2.3.1 Installing the CPU

CAUTION!



- Ensure that you install the correct CPU designed for LGA 1851 socket only. DO NOT install a CPU designed for other sockets on the LGA 1851 socket.
 - ASUS will not cover damages resulting from incorrect CPU installation/removal, incorrect CPU orientation/placement, or other damages resulting from negligence by the user.
-

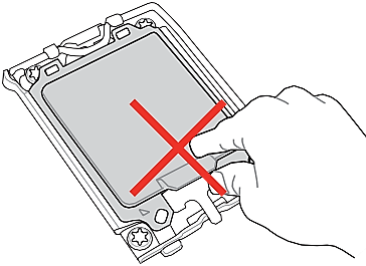

CAUTION!

Take caution when lifting the load lever, ensure to hold onto the load lever when releasing the load lever. Letting go of the load lever immediately after releasing it may cause the load lever to spring back and cause damage to your motherboard.

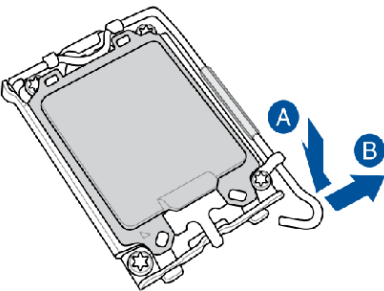

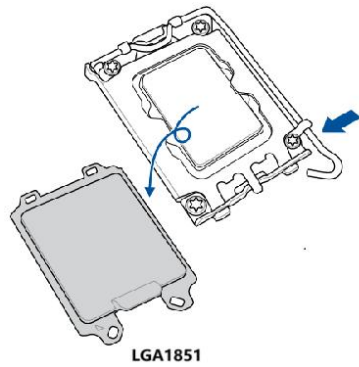
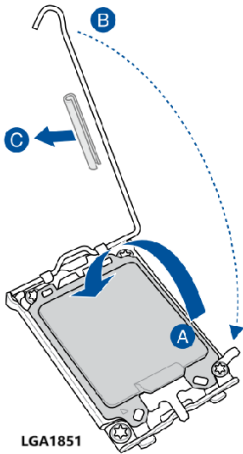
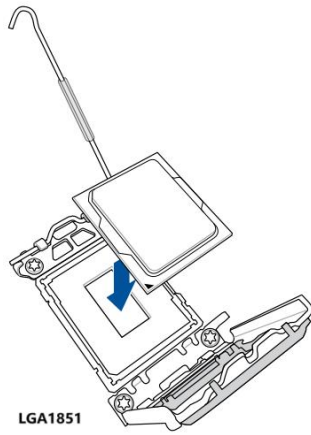
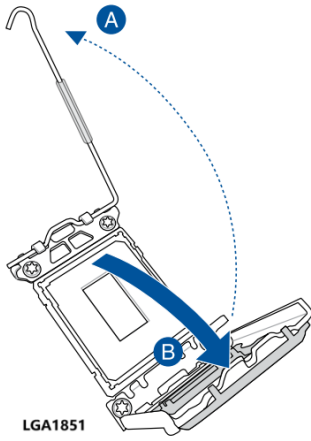

2.3.2 CPU Heatsink and Fan Assembly Installation

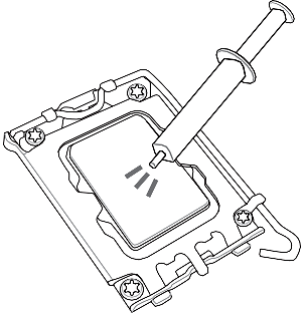

IMPORTANT: Apply Thermal Interface Material to the CPU cooling system and CPU before you install the cooling system, if necessary

CAUTION! Ensure to remove the CPU Socket lever protector on the lever latch before installing the cooling system, failure to do so may cause damages to your system.

Installing CPU Heatsink and Fan:

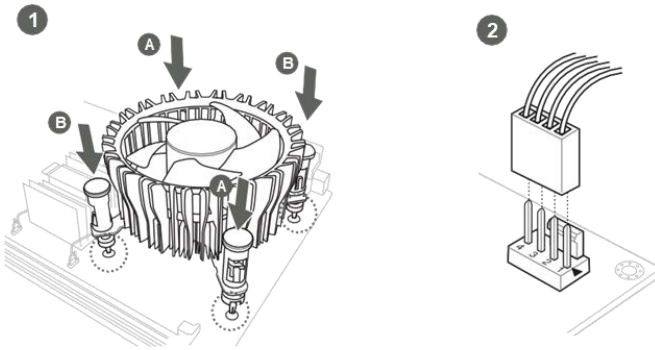

Uninstalling the CPU Heatsink and Fan:

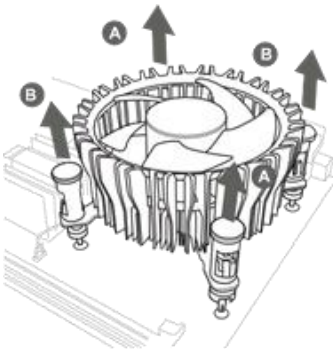

2.3.3 System Memory

The motherboard comes with Unbuffered Dual Inline Memory Module/Clocked Unbuffered Dual In-line Memory Module (U/CU-DIMM) slots designed for DDR5 (Double Data Rate 5) memory modules.



CAUTION! A DDR5 memory module is notched differently from a DDR, DDR2, or DDR3 module. DO NOT install a DDR, DDR2, DDR3, or DDR4 memory module to the DDR5 slot.

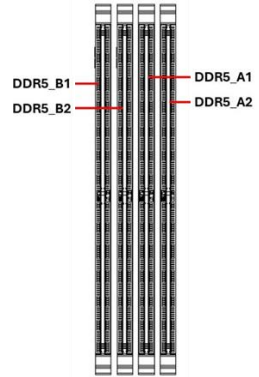
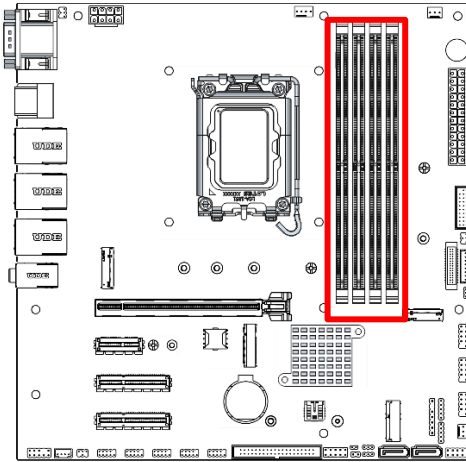

2.3.4 DIMM Installation

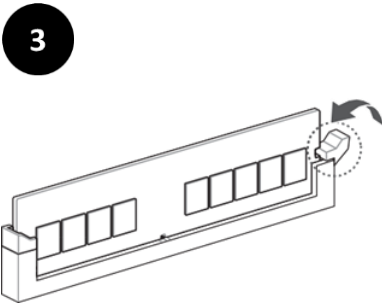
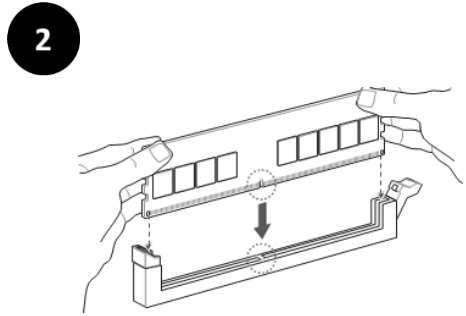
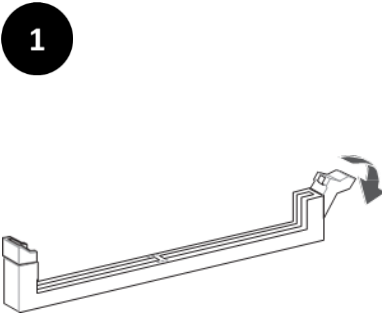

DIMM Removal:

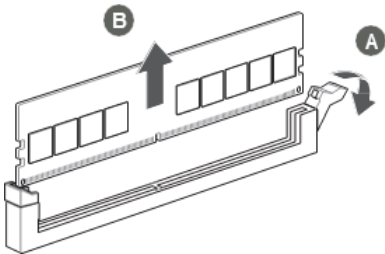

2.4. Jumpers

Please refer to the table below for all of the board's jumpers that you can configure for your application

Label	Function
JP2	COM 1 Header Pin-9 Function Select
JP3	COM 2 Header Pin-9 Function Select
JP4	GPIO/80 Port Function Select
JP11	Inverter VCC 5V/12V Function Select
JP12	LVDS PVCC 3.3V/5V/12V Function Select
JAT_ATX	ATX Mode/AT Mode Select
JBAT1	Clear CMOS Function Select
JCOPEN1	Case Open Function Select

2.4.1 COM1 Header Pin-9 Function Select (JP2)

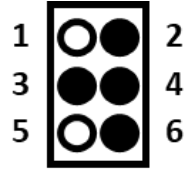
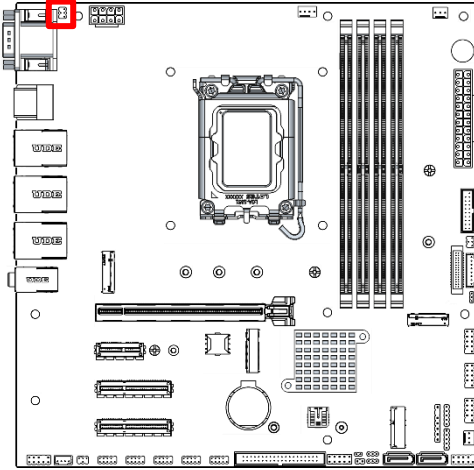

Setting	Pin Configuration
RI = RS232	2-4 Closed
RI = +5V	3-4 Closed
RI = +12V	4-6 Closed

2.4.2 COM 2 Header Pin-9 Function Select (JP3)

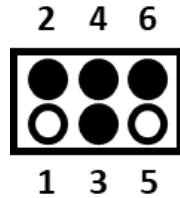
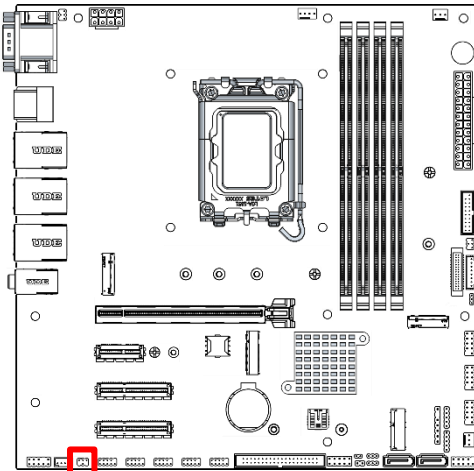

Setting	Pin Configuration
RI = RS232	2-4 Closed
RI = +5V	3-4 Closed
RI = +12V	4-6 Closed

2.4.3 GPIO/80 Port Function Select (JP4)

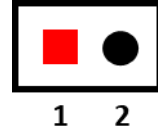
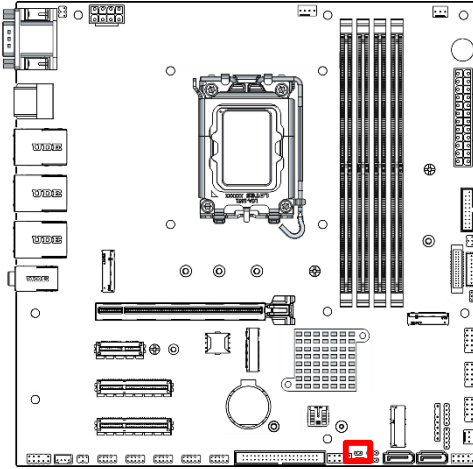

Setting	Pin Configuration
GPIO=80 Port	1-2 Open
Function as GPIO Port	1-2 Closed

2.4.4 Inverter VCC 5V/12V Function Select (JP11)

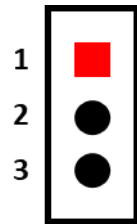
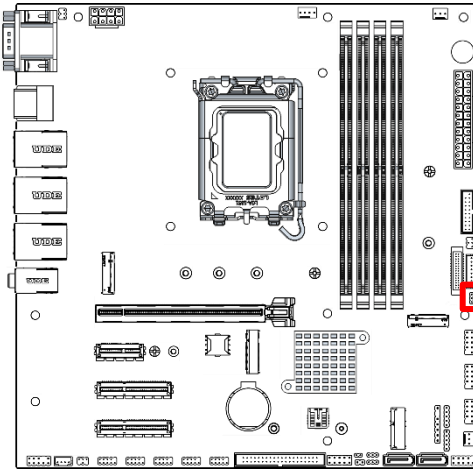

Setting	Pin Configuration
Inverter VCC=5V	1-2 Closed
Inverter VCC=12V	2-3 Closed

2.4.5 LVDS PVCC 3.3V/5V/12V Function Select (JP12)

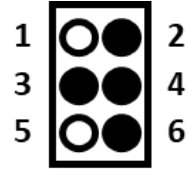
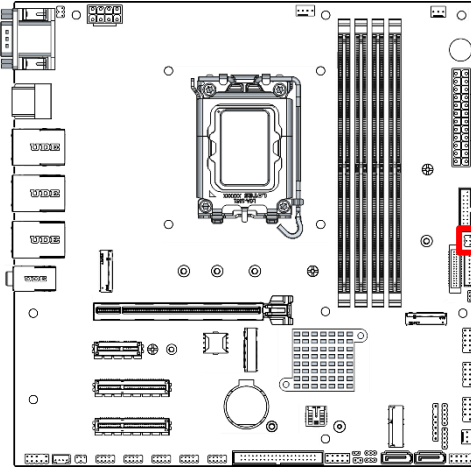

Setting	Pin Configuration
RI = RS232	2-4 Closed
RI = +5V	3-4 Closed
RI = +12V	4-6 Closed

2.4.6 ATX Mode/AT Mode Select (JAT_ATX)

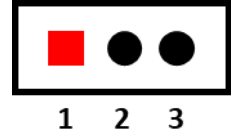
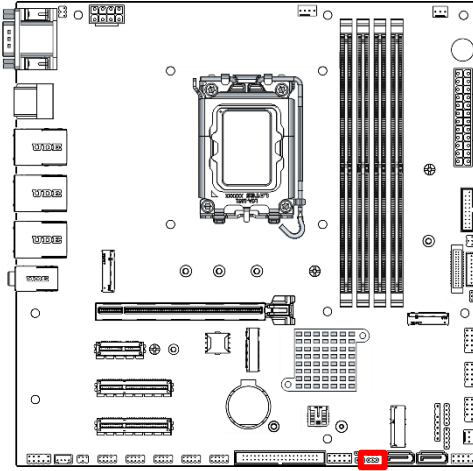

Setting	Pin Configuration
ATX Mode Selected	1-2 Closed
AT Mode Selected	2-3 Closed

2.4.7 Clear CMOS Function Select (JBAT1)

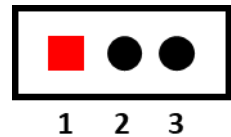
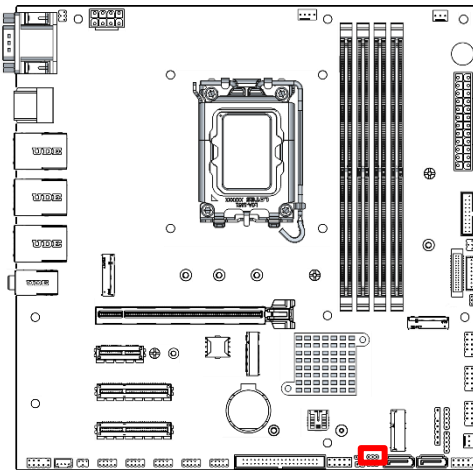

Setting	Pin Configuration
Normal	1-2 Closed
Clear CMOS	2-3 Closed

2.4.8 Case Open Function Select (JCOPEN1)

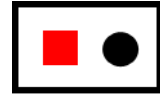
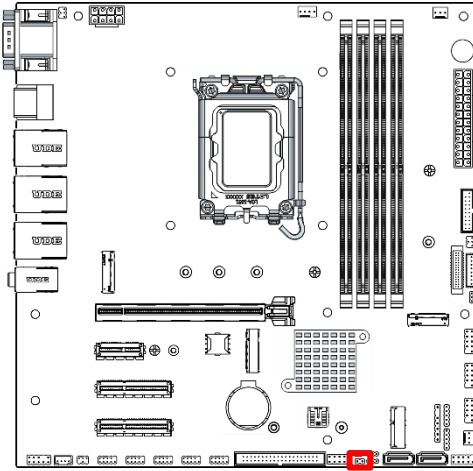

1 2

Setting	Pin Configuration
CASE OPEN	1
GND	2

2.5. Internal Connectors

Please refer to the table below for all of the board's connectors that you can configure for your application.

Rear I/O Ports

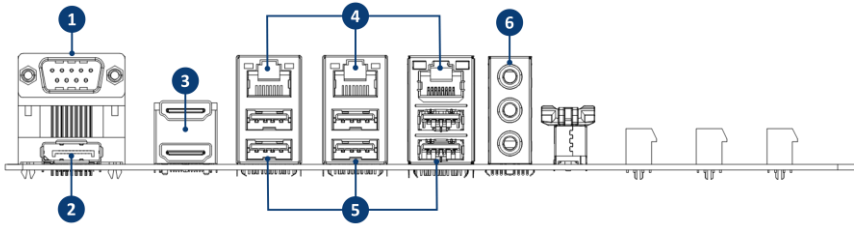

Label	Function
1	DB-9 for RS-232/422/485 x 1
2	DP 1.4a x 1 (Max Resolution: 4096 x 2160 @60Hz)
3	HDMI 2.1 TMDS x 2 (Max Resolution: 4096 x 2160 @60Hz)
4	2.5GbE LAN x 3
5	USB 3.2 (Gen 2) x 6
6	Audio Jack for Mic-in, Line-out, Line-in

Internal Connectors

Label	Function
COM1	Serial Port (RS-232/422/485) Connector
DP1	Display Port Connector
HDMI1-HDMI2	Dual HDMI Connector
UL1 (LAN)	2.5GbE RJ-45 LAN Port Connector
UL1 (USB 3.2 Gen.2)	USB 3.2 Gen 2 Port Connector
UL2 (LAN)	2.5GbE RJ-45 LAN Port Connector
UL2 (USB 3.2 Gen.2)	USB 3.2 Gen 2 Port Connector
UL3 (LAN)	2.5GbE RJ-45 LAN Port Connector
UL3 (USB 3.2 Gen.2)	USB 3.2 Gen 2 Port Connector
AUDIO1	Audio Line In/Line Out/Mic Connector
FP_AUDIO1	Front Panel Audio Header
SPEAK_CON1	3W Amplifier Wafer
COM 2/3/4/5/6	RS-232 Serial Port Header
COM7-10	RS-232 Serial Port Header
GPIO1	GPIO Port Header

Label	Function
SATA 1/2	SATA Port Connector
FP	Front Panel Header (PWR LED/HDD LED/Power Button/Reset)
CPUFAN1	CPU Fan Connector
SYSFAN 1/2	System Fan Connector
PS2KBMS1	PS/2 Keyboard and Mouse Header
SMBUS1	SMBus Header
I2C1	I2C Header
FP_USB 2/3/4	USB 2.0 Port Header
LVDS_EDP1	LVDS/eDP Header
INVERTER1	LVDS/eDP Inverter Wafer
FP_USB1	USB 3.2 Gen 1 Port Header
M2M1	M.2 2242/2260/2280/22110 M-Key Slot
M2M2	M.2 2242/2280 M-Key Slot
M2E1	M.2 2230 E-Key Slot
M2B1	M.2 2242/3052 B-Key Slot
SIMCARDB1	Nano SIM Card Slot
ATXPWR1	24-pin ATX Power Supply Connector
ATX12V1	8-pin ATX 12V Power Connector
DDR5_A1	DDR5 U-DIMM Socket
DDR5_A2	DDR5 U-DIMM Socket
DDR5_B1	DDR5 U-DIMM Socket
DDR5_B2	DDR5 U-DIMM Socket
PCIE1	PCIe Gen 5 [x16] Slot
PCIE2	PCIe Gen 4 [x1] Slot
PCIE3	PCIe Gen 4 [x4] Slot
PCIE4	PCIe Gen 4 [x4] Slot

2.5.1 Serial Port (RS-232/422/485) Connector (COM1)

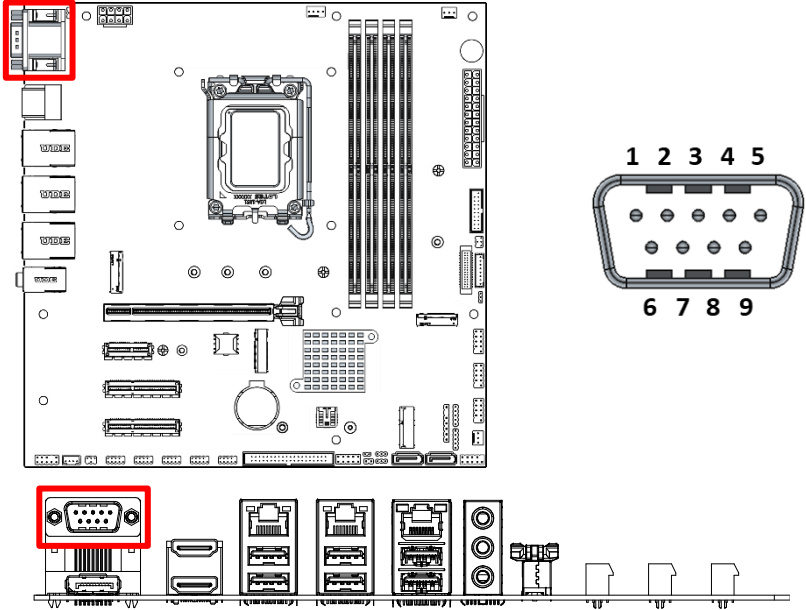

RS-232			
Pin	Signal	Pin	Signal
1	DCD	2	RXD
3	TXD	4	DTR
5	GND	6	DSR
7	RTS	8	CTS
9	RI	-	-

RS-422			
Pin	Signal	Pin	Signal
1	TX-	2	TX+
3	RX+	4	RX-
5	GND	6	NC
7	NC	8	NC
9	NC	-	-

RS-485			
Pin	Signal	Pin	Signal
1	DATA-	2	DATA+
3	NC	4	NC
5	GND	6	NC
7	NC	8	NC

RS-485			
Pin	Signal	Pin	Signal
9	NC	-	-

2.5.2 Display Port Connector (DP1)

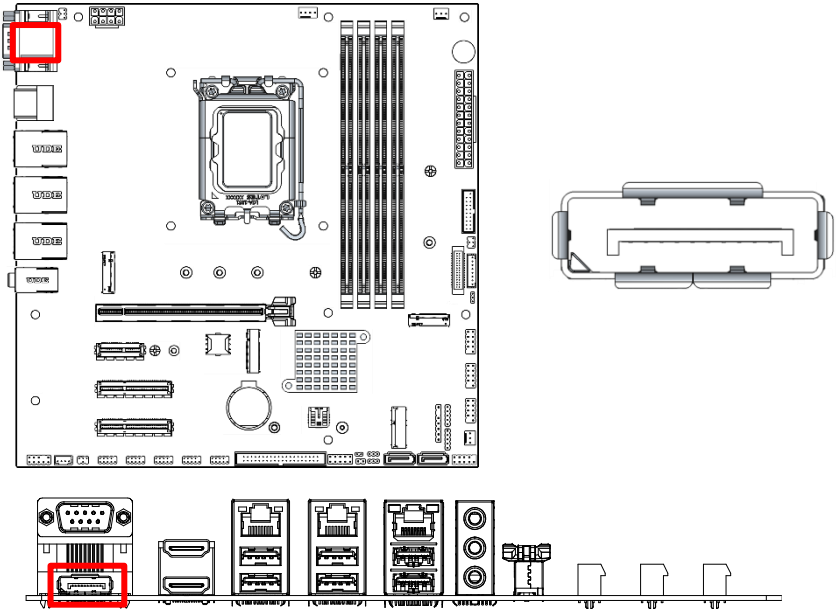

Note: Standard specifications.

2.5.3 Dual HDMI Connector (HDMI1-HDMI2)

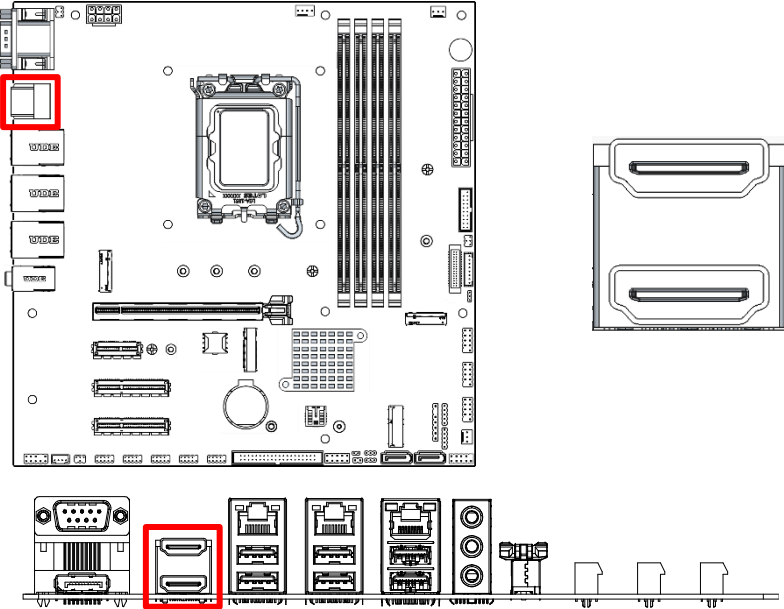

Note: Standard specifications.

2.5.4 RJ-45 2.5GbE LAN Port Connector (UL1)

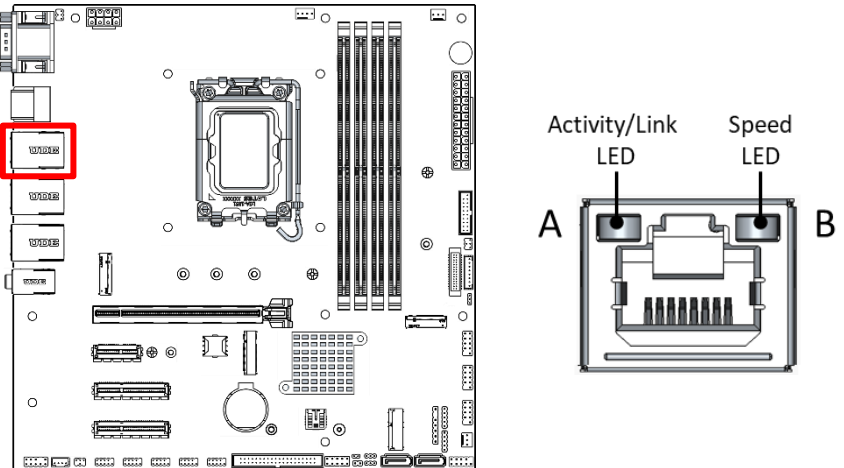

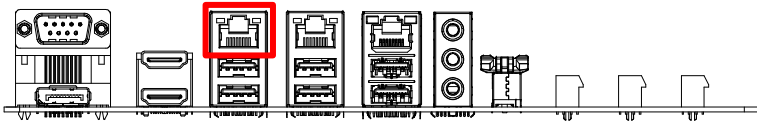

A: Activity/Link LED		B: Speed LED	
Status	Description	Status	Description
Off	No Link	Off	10/100Mbps
Blinking	Data Activity	Orange	1Gbps
On	Link	Green	2.5Gbps

Note: 2.5Gbps high-speed transmission rate is only supported over CAT 5e UTP cable.

2.5.5 USB 3.2 Gen 2 Port Connector (UL1)

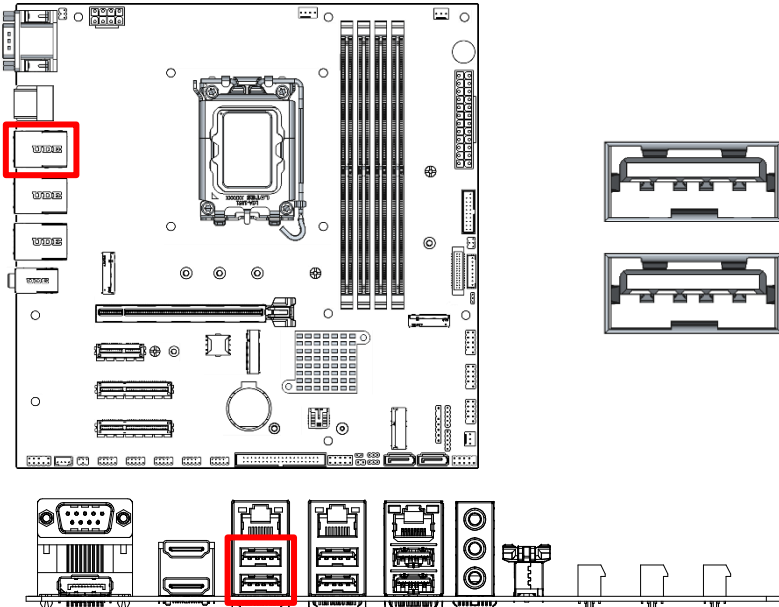

Note: Standard specifications.

2.5.6 RJ-45 2.5GbE LAN Port Connector (UL2)

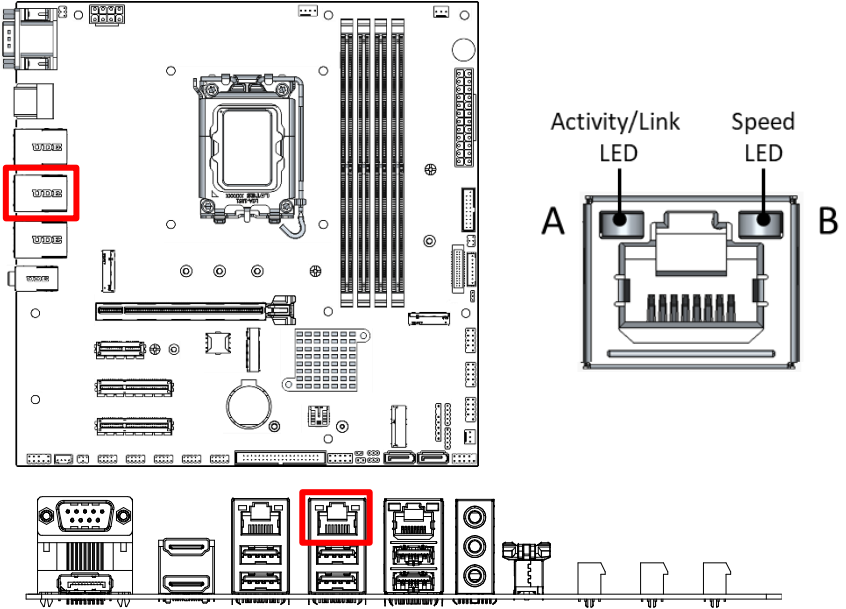

A: Activity/Link LED		B: Speed LED	
Status	Description	Status	Description
Off	No Link	Off	10/100Mbps
Blinking	Data Activity	Orange	1Gbps
On	Link	Green	2.5Gbps

Note: 2.5Gbps high-speed transmission rate is only supported over CAT 5e UTP cable.

2.5.7 USB 3.2 Gen 2 Port Connector (UL2)

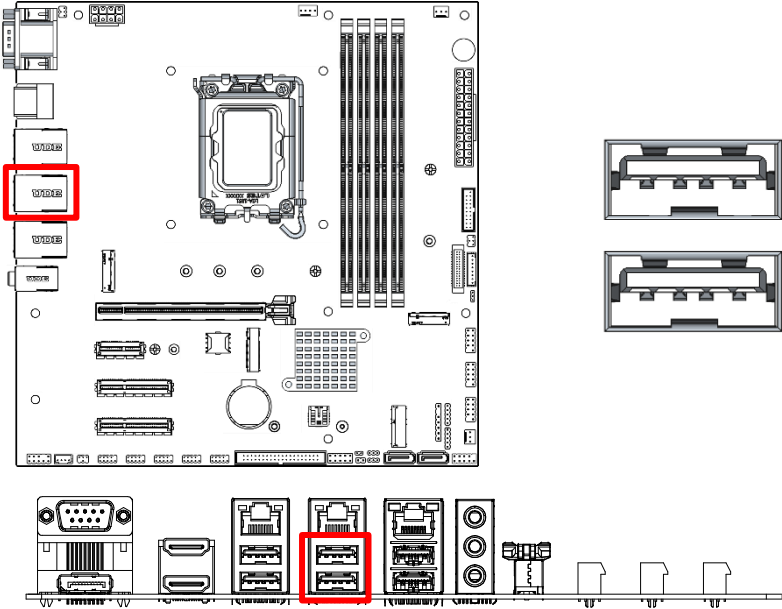

Note: Standard specifications.

2.5.8 RJ-45 2.5GbE LAN Port Connector (UL3)

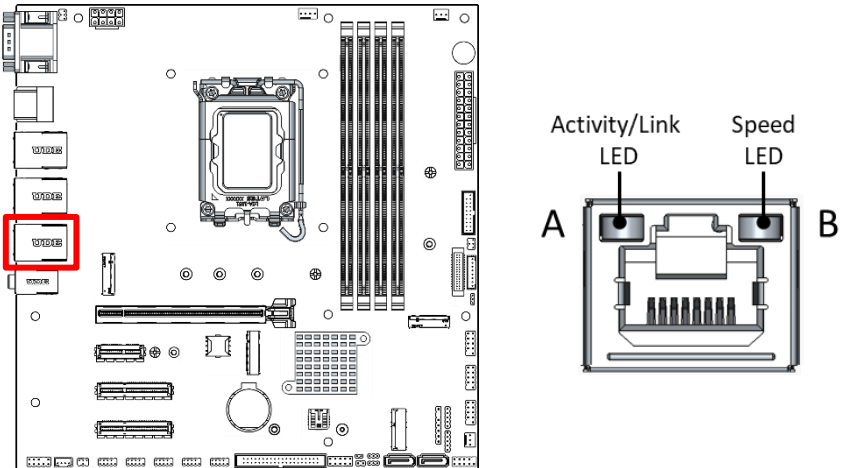

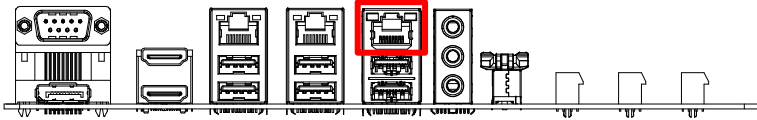

A: Activity/Link LED		B: Speed LED	
Status	Description	Status	Description
Off	No Link	Off	10/100Mbps
Blinking	Data Activity	Orange	1Gbps
On	Link	Green	2.5Gbps

Note: 2.5Gbps high-speed transmission rate is only supported over CAT 5e UTP cable.

2.5.9 USB 3.2 Gen 2 Port Connector (UL3)

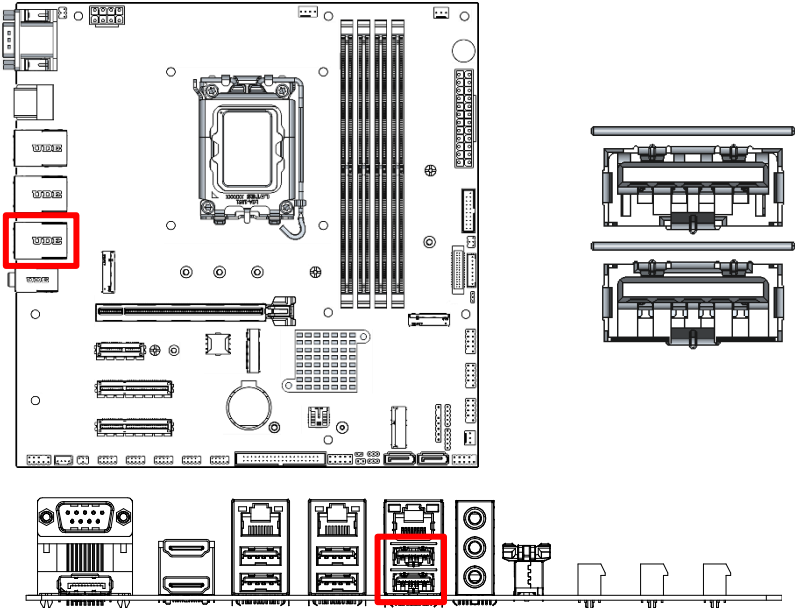

Note: Standard specifications.

2.5.10 Audio Line In/Line Out/Mic Connector (AUDIO1)

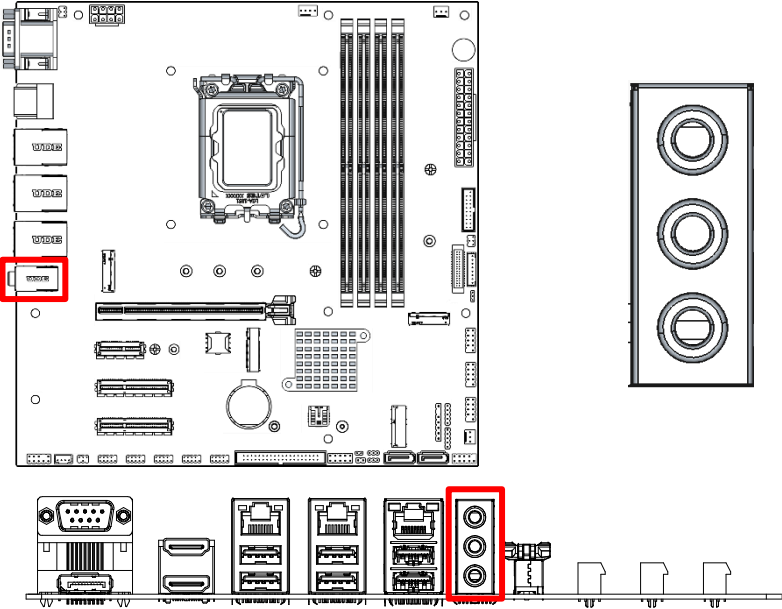

Note: Standard specifications.

2.5.11 Front Panel Audio Header (FP_AUDIO1)

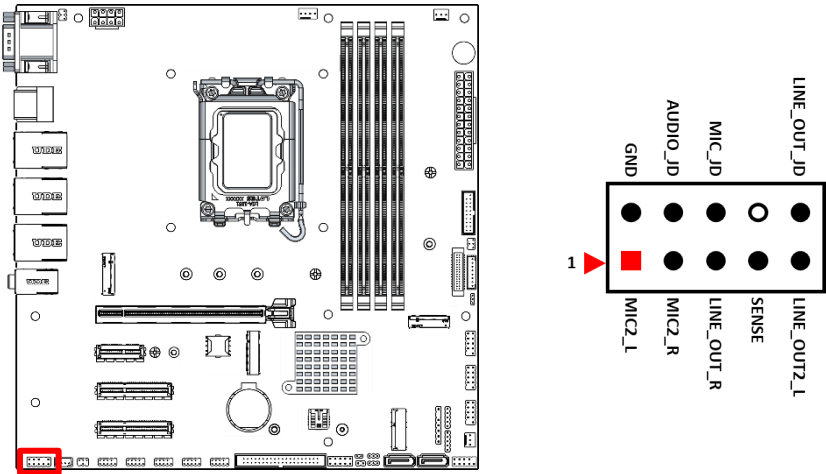

2.5.12 3W Amplifier Wafer (SPEAK_CON1)

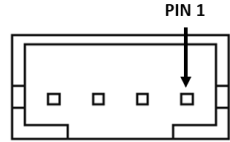
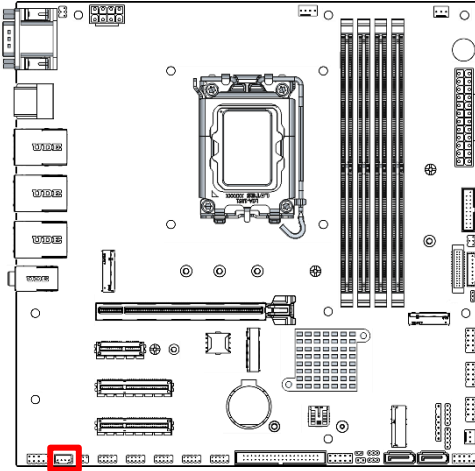

Pin	Signal
1	L-
2	L+
3	R+
4	R-

2.5.13 RS-232 Serial Port Header (COM 2/3/4/5/6)

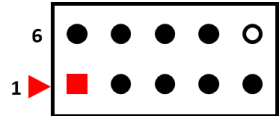
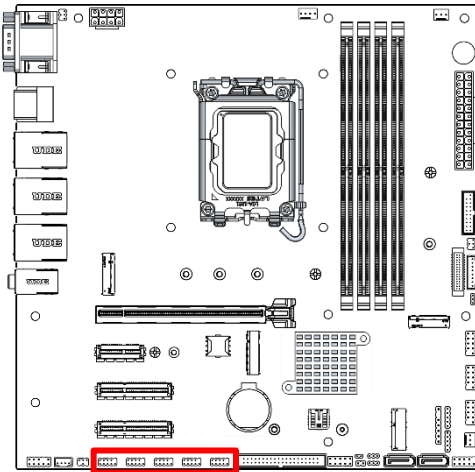

Pin No.	Pin 6	Pin 7	Pin 8	Pin 9	
RS-232	DSR	RTS	CTS	RI	

Pin No.	Pin 6	Pin 7	Pin 8	Pin 9	
Pin No.	Pin 1	Pin 2	Pin 3	Pin 4	Pin 5
RS-232	DCD	RXD	TXD	DTR	GND

2.5.14 RS-232 Serial Port Header (COM7-10)

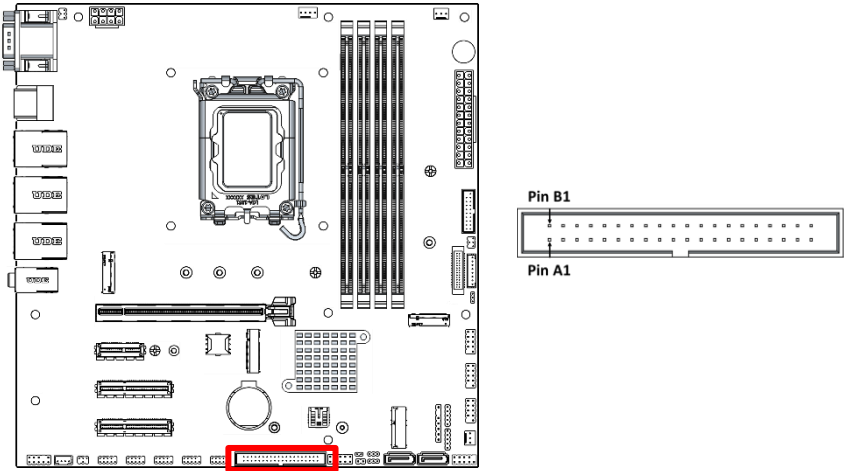

COM7-10	Pin No.	RS-232	Pin No.	RS-232
COM7	Pin A1	DCD7	Pin B1	DSR7
	Pin A2	SIN7	Pin B2	RTS7
	Pin A3	SOUT7	Pin B3	CTS7
	Pin A4	DTR7	Pin B4	RI7
	Pin A5	GND	Pin B5	N/A
COM8	Pin A6	DCD8	Pin B6	DSR8
	Pin A7	SIN8	Pin B7	RTS8
	Pin A8	SOUT8	Pin B8	CTS8
	Pin A9	DTR8	Pin B9	RI8
	Pin A10	GND	Pin B10	N/A
COM9	Pin A11	DCD9	Pin B11	DSR9
	Pin A12	SIN9	Pin B12	RTS9
	Pin A13	SOUT9	Pin B13	CTS9
	Pin A14	DTR9	Pin B14	RI9
	Pin A15	GND	Pin B15	N/A
COM10	Pin A16	DCD10	Pin B16	DSR10
	Pin A17	SIN10	Pin B17	RTS10
	Pin A18	SOUT10	Pin B18	CTS10
COM10 (Cont.)	Pin A19	DTR10	Pin B19	RI10
	Pin A20	GND	Pin B20	N/A

Note: COM7-10 ports are optional and by request only.

2.5.15 GPIO Port Header (GPIO1)

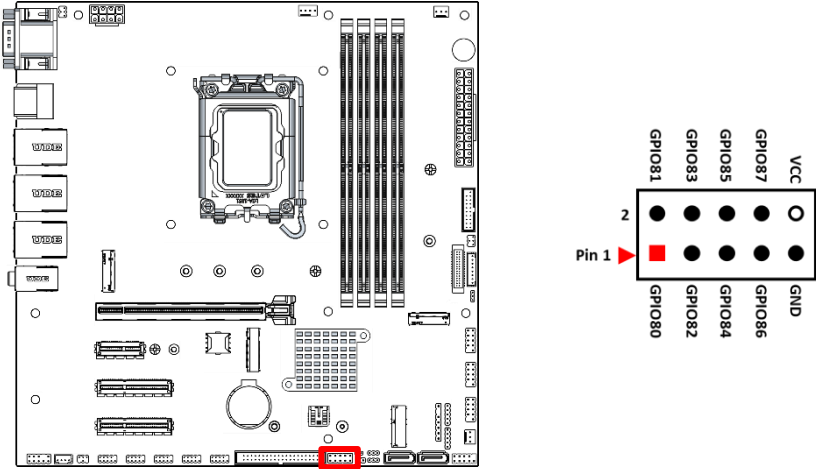

Setting	Pin Configuration
80 Port Function	JP4 Open
Normal 8-bit GPIO	JP4 Closed

2.5.16 SATA Port Connector (SATA 1/2)

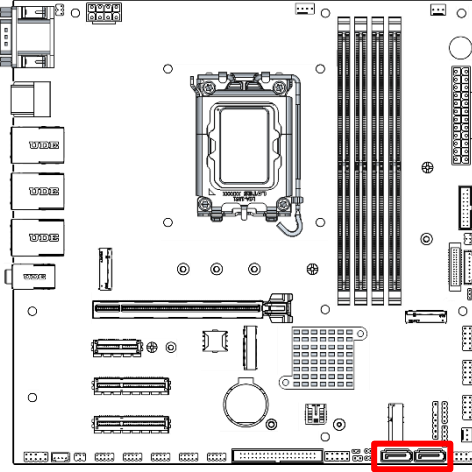

Pin	Signal
1	GND
2	TXP
3	TXN
4	GND
5	RXN
6	RXP
7	GND

2.5.17 Front Panel Header (FP)

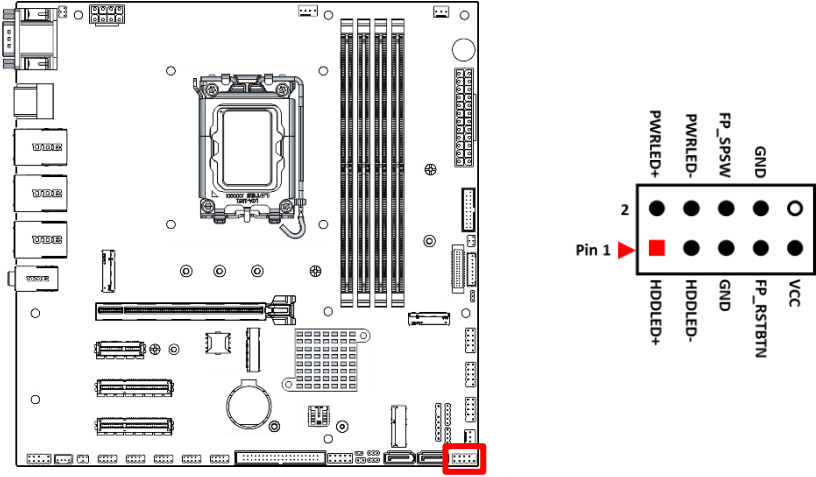

2.5.18 CPU Fan Connector (CPUFAN1)

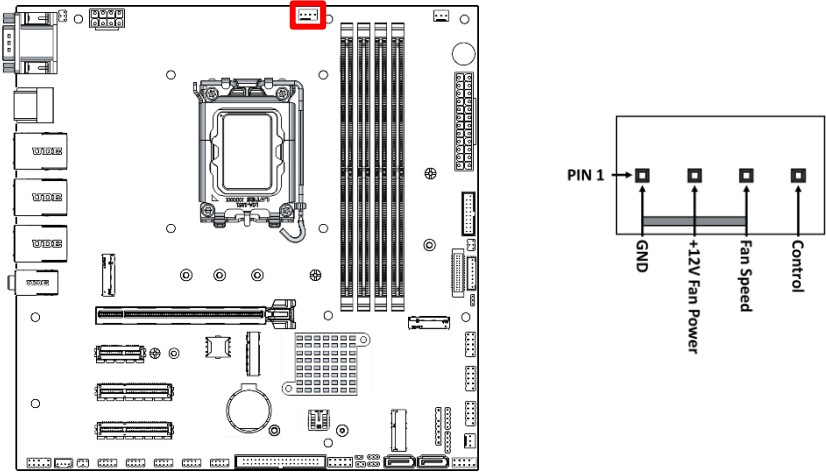

2.5.19 System Fan Connector (SYSFAN1/2)

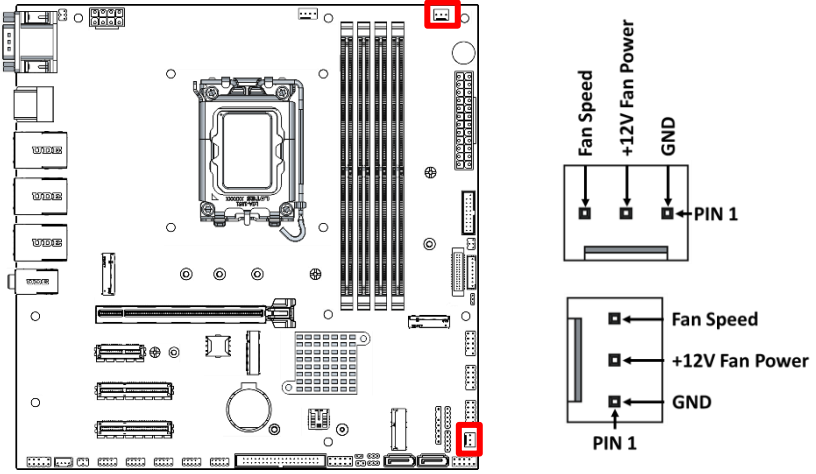

2.5.20 PS/2 Keyboard and Mouse Header (PS2KBMS1)

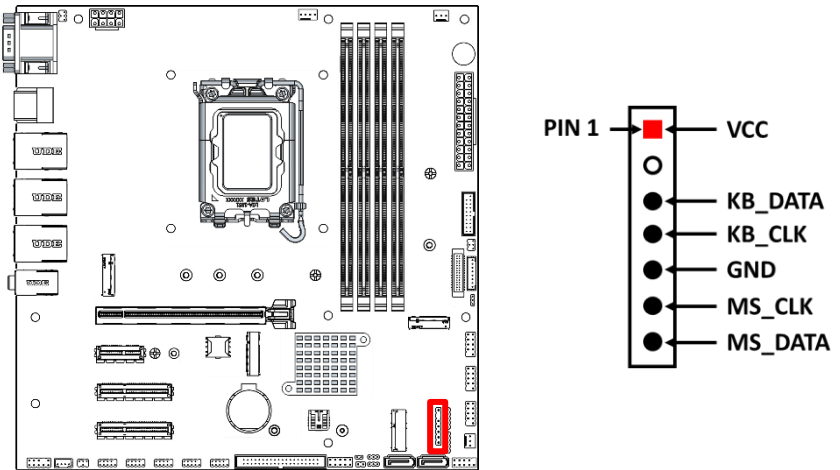

2.5.21 SMBus Header (SMBUS1)

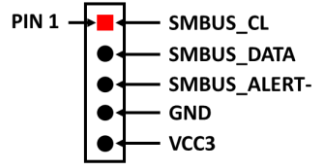
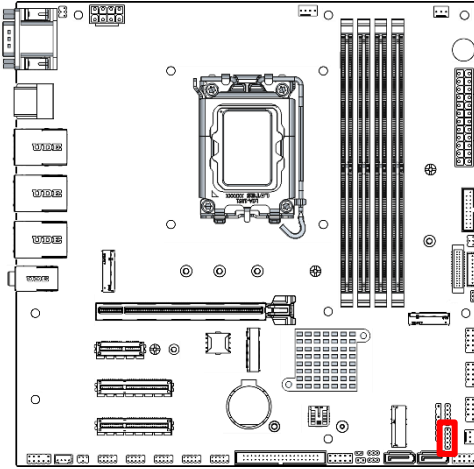

2.5.22 I2C Header (I2C1)

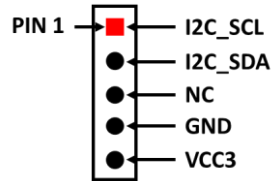
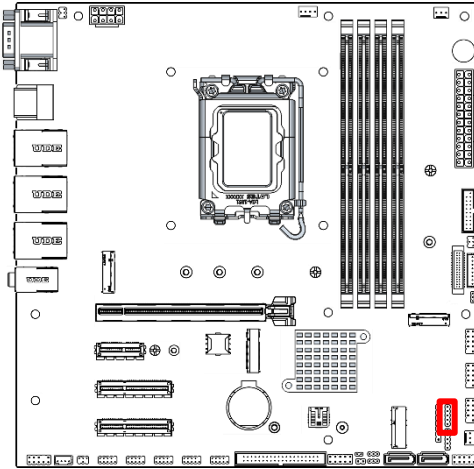

2.5.23 USB 2.0 Port Header (FP_USB 2/3/4)

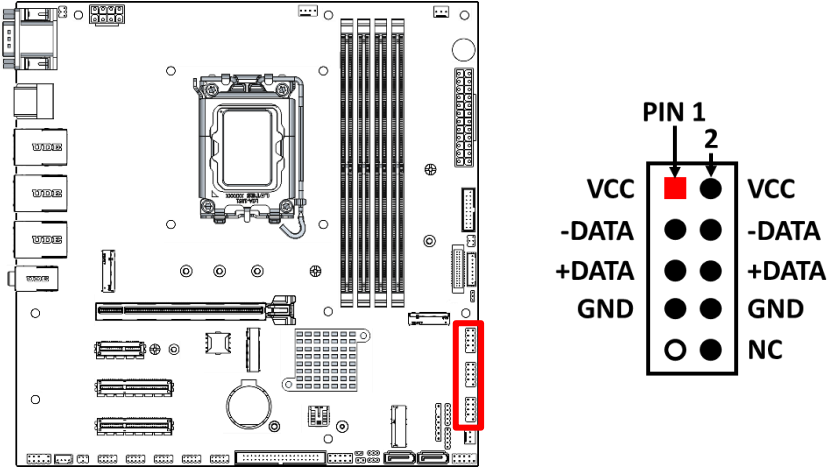

2.5.24 LVDS/eDP Header (LVDS_EDP1)

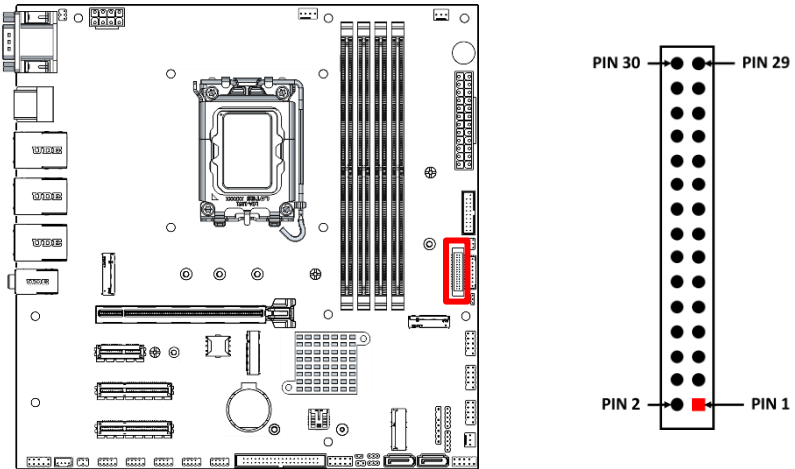

Pin Define	Pin No.	Pin No.	Pin Define
LCD_VCC	Pin 30	Pin 29	LCD_VCC
LCD_VCC	Pin 28	Pin 27	LCD_VCC
LVDSA_DATAN0	Pin 26	Pin 25	LVDSA_DATAP0
LVDSA_DATAN1	Pin 24	Pin 23	LVDSA_DATAP1
LVDSA_DATAN2	Pin 22	Pin 21	LVDSA_DATAP2
LVDS_CLKAN	Pin 20	Pin 19	LVDS_CLKAP
LVDSA_DATAN3	Pin 18	Pin 17	LVDSA_DATAP3

Pin Define	Pin No.	Pin No.	Pin Define
GND	Pin 16	Pin 15	GND
GND	Pin 14	Pin 13	GND
LVDS_DDC_SCL	Pin 12	Pin 11	LVDS_DDC_SDA
LVDSB_DATAP0	Pin 10	Pin 9	LVDSB_DATAN0
LVDSB_DATAP1	Pin 8	Pin 7	LVDSB_DATAN1
LVDSB_DATAP2	Pin 6	Pin 5	LVDSB_DATAN2
LVDSB_CLKP	Pin 4	Pin 3	LVDSB_CLKBN
LVDSB_DATAP3	Pin 2	Pin 1	LVDSB_DATAN3

2.5.25 LVDS_eDP Inverter Wafer (INVERTER1)

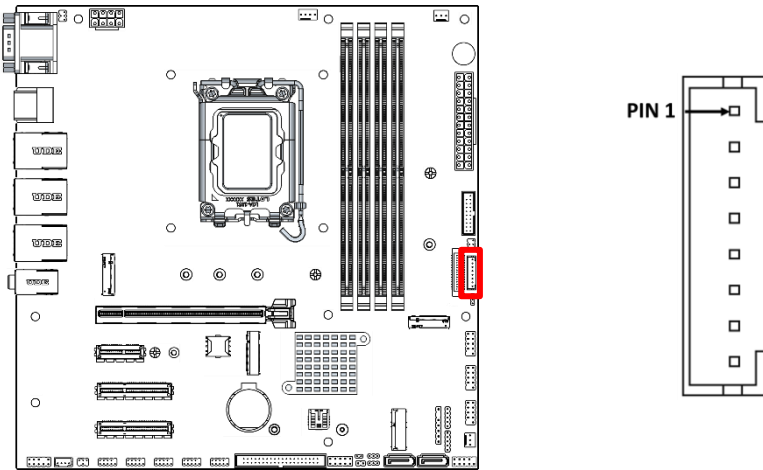

Pin	Signal
1	LCD_BKLT_EN
2	LCD_BKLT_PWM
3	Backlight VCC
4	Backlight VCC
5	GND
6	GND
7	BRTNSS_UP
8	BRTNSS_DOWN

2.5.26 USB 3.2 Gen 1 Port Header (FP_USB1)

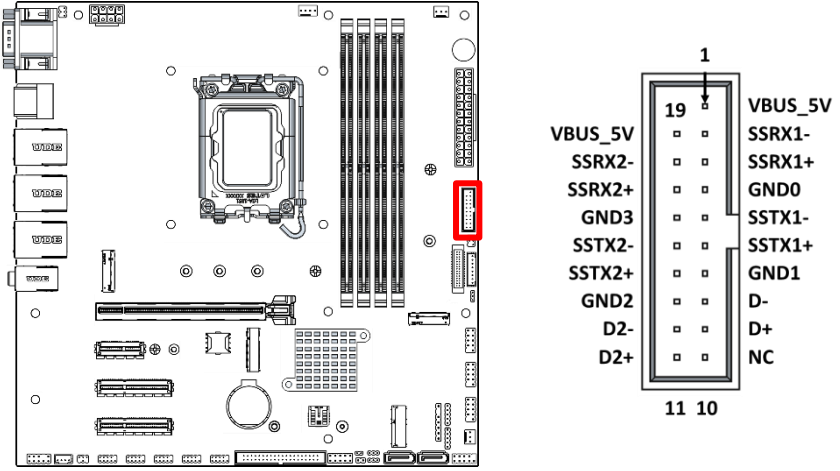

2.5.27 M.2 2242/2260/2280/22110 M-Key Slot (M2M1)

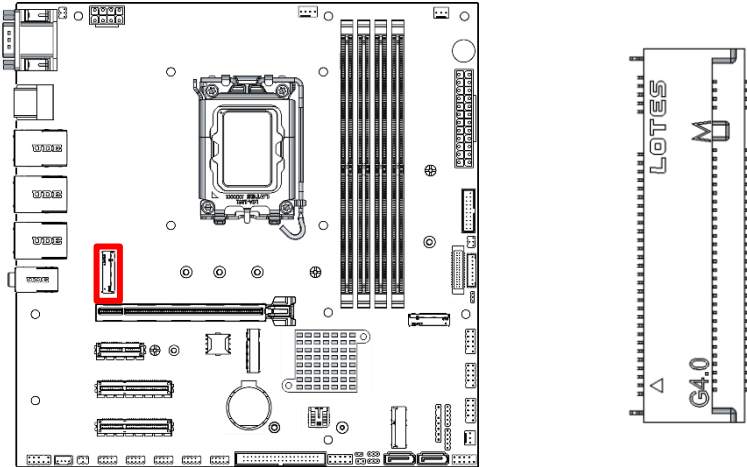

Note: Standard specifications

2.5.28 M.2 2242/2280 M-Key Slot (M2M2)

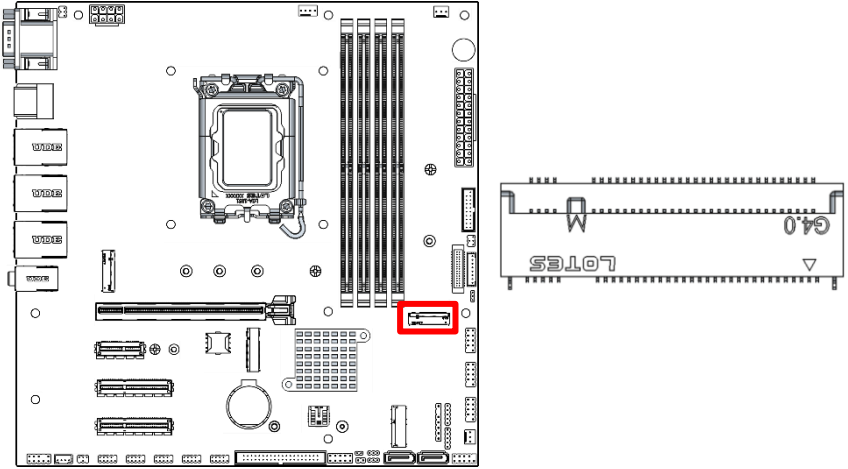

Note: Standard specifications

2.5.29 M.2 2230 E-Key Slot (M2E1)

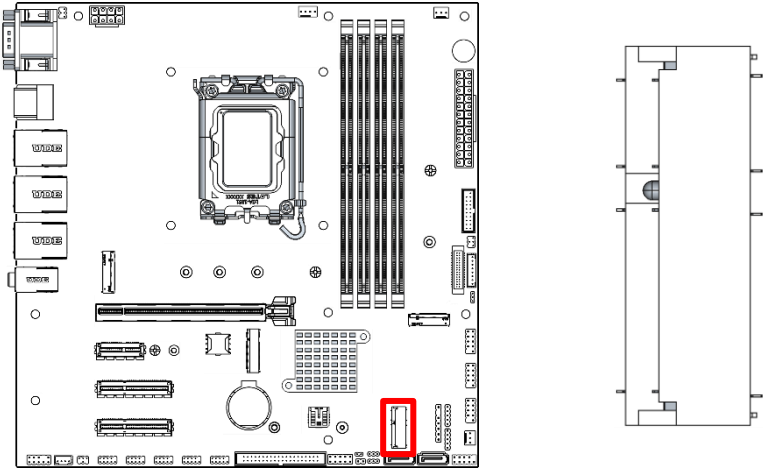

Note: Standard specifications

2.5.30 M.2 2242/3052 B-Key Slot (M2B1)

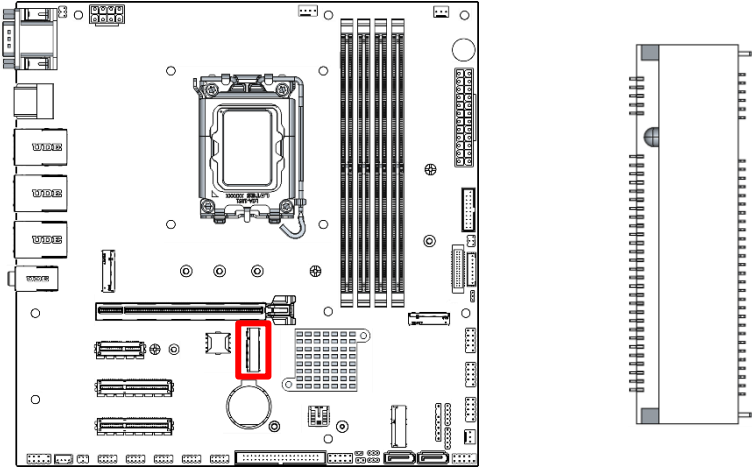

Note: Standard specifications

2.5.31 Nano SIM Card Slot (SIMCARD B1)

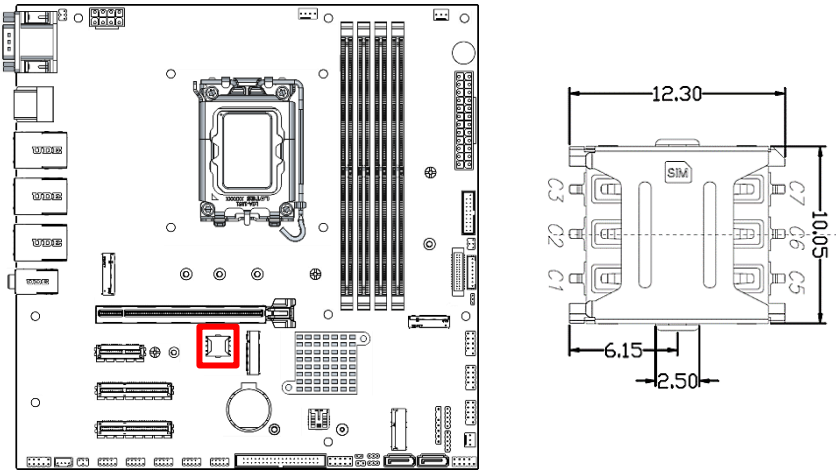

Note: Standard specifications

2.5.32 24-pin ATX Power Supply Connector (ATXPWR1)

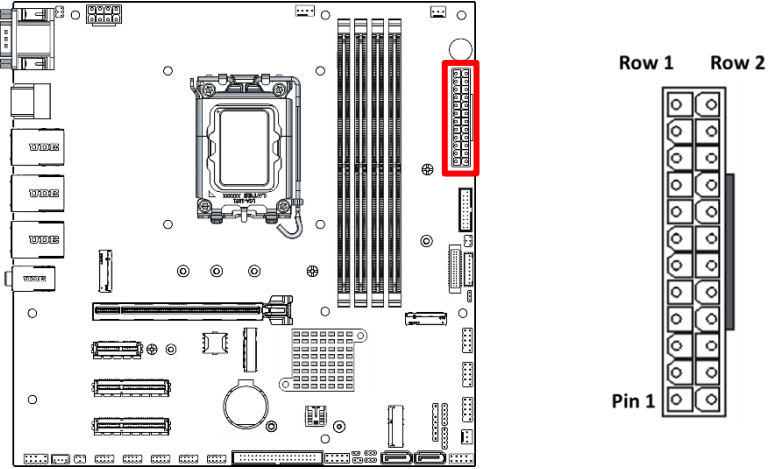

Pin	Row 1	Row 2
1	3.3V	3.3V
2	3.3V	-12V
3	GND	GND
4	5V	Soft Power On
5	GND	GND
6	5V	GND
7	GND	GND
8	Power OK	-5V
9	+5V (for Soft Logic)	+5V
10	-12V	+5V
11	-12V	+5V
12	-3V	GND

Note: Standard specifications

2.5.33 8-pin ATX 12V Power Connector (ATX12V1)

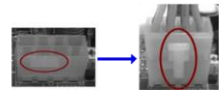
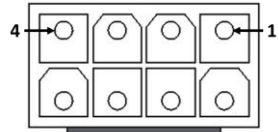
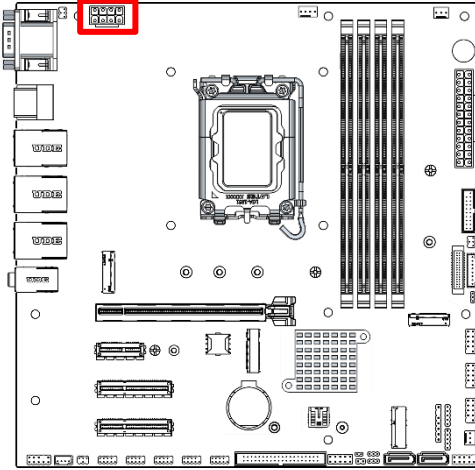

Pin	Definition	Pin	Definition
1	GND	5	+12V
2	GND	6	+12V
3	GND	7	+12V
4	GND	8	+12V

2.5.34 DDR5 U-DIMM Socket (DDR5_ A1/A2/B1/B2)

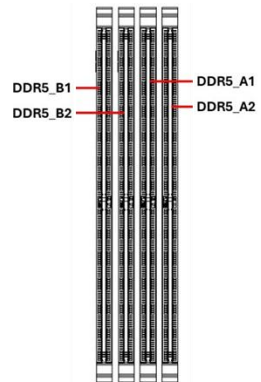
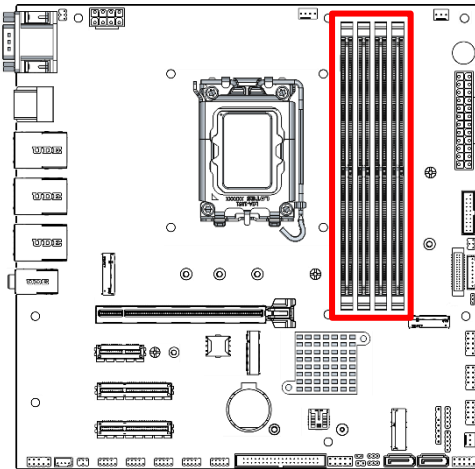

Note:

- Always install the first memory module in the DDR5_A2 socket.
- Dual-channel mode is supported only when memory modules are installed in pairs. Installing one or three modules will prevent dual-channel operation. Install paired modules starting from the right-most sockets and proceed leftward.
- Ensure each memory module is oriented correctly before installation. Installing a module in the wrong direction may cause permanent damage to both the motherboard and the memory module.

Memory module installation recommendation:

Configuration	DDR5_B1	DDR5_B2	DDR5_A1	DDR5_A2
1	--	--	--	install
2	--	install	--	install
4	install	install	install	install

2.5.35 PCIe Gen 5 [x16] Slot (PCIe1)

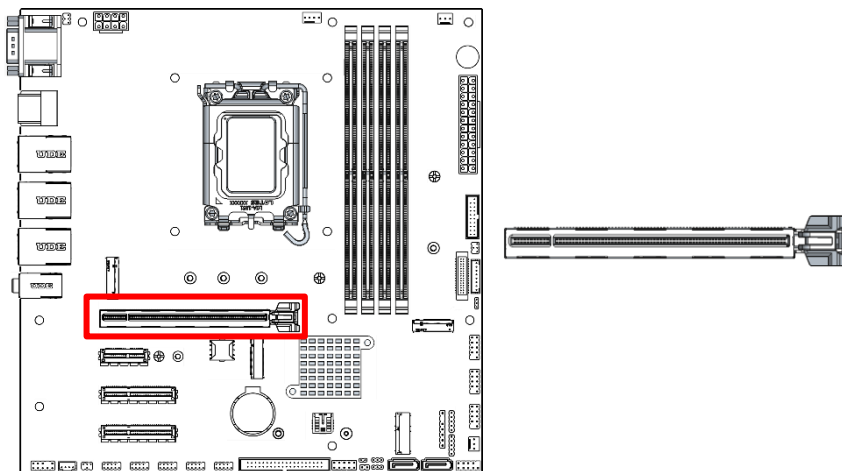

Note: Standard specifications

2.5.36 PCIe Gen 4 [x1] Slot (PCIE2)

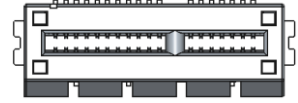
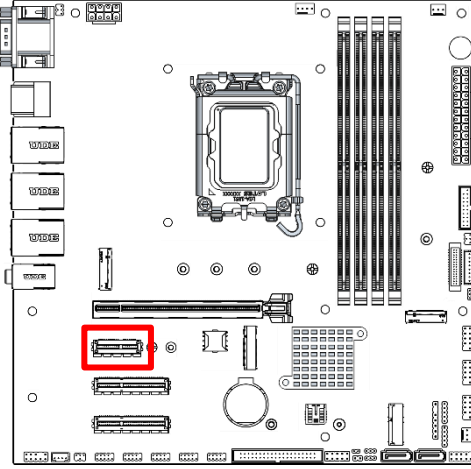

Note: Standard specifications

2.5.37 PCIe Gen 4 [x4] Slot (PCIE3/4)

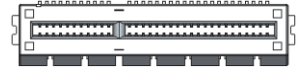
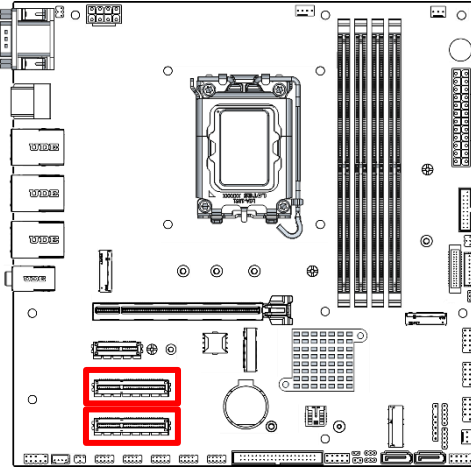

Note: Standard specifications

2.6. Maximum Voltage & Current Limits

Below is a list of maximum voltage & Current Limit specification for motherboard interface (including but not limited to slots, connectors and headers) for setup reference:

Parts	Working Voltage	Current Support	
USB Port	UL1 USB3.2 Gen.2	5V	900mAx2
	UL2 USB3.2 Gen.2	5V	900mAx2
	UL3 USB3.2 Gen.2	5V	900mAx2
	FP_USB1	5V	900mAx2
	FP_USB2	5V	500mAx2
	FP_USB3	5V	500mAx2
	FP_USB3	5V	500mAx2
FP	5V	1A	
LVDS_EDP1	3.3V/5V/12V (via jumper setting)	2A	
INVERTER1	5V/12V (via jumper setting)	2A	
CPUFAN1/SYSFAN1/SYSFAN2	12V	1A	
GPIO1	5V	500mA	
PS2KBMS1	5V	500mA	
SMBUS1	3.3V	500mA	
I2C1	3.3V	500mA	

Chapter 3

BIOS Setup

3.1 BIOS Setup Program

Use the BIOS Setup program to configure its parameters. The BIOS screens include navigation keys and brief online help to guide you in using the BIOS Setup program.

Entering BIOS Setup at startup

To enter BIOS Setup at startup:

Press **** during the Power-On Self Test (POST). If you do not press ****, POST continues with its routine.

Entering BIOS Setup after POST

To enter BIOS Setup after POST:

- Press **<Ctrl>+<Alt>+** simultaneously.
- Press the reset button on the system chassis.
- Press the power button to turn the system off then back on. Do this option only if you failed to enter BIOS Setup using the first two options.



CAUTION! Using the power button, reset button, or the **<Ctrl>+<Alt>+** keys to reboot a running operating system can cause damage to your data or system. Always shut down the system properly from the operating system.

IMPORTANT:

- The default BIOS settings for this motherboard apply to most working conditions and ensures optimal performance. If the system becomes unstable after changing any BIOS settings, load the default settings to regain system stability. Select the option **Restore Defaults** under the Save & Exit Menu. See section **3.7 Save & Exit**.
- The BIOS setup screens shown in this section are for reference purposes only, and may not exactly match what you see on your screen.



3.2 BIOS Menu Screen

The menu bar on top of the screen has the following main items:

Main - For changing the basic system configuration.

Advanced - For changing the advanced system settings.

Chipset - For viewing and changing chipset settings.

Security - For setting up BIOS security settings.

Boot - For changing the system boot configuration.

Save & Exit - For selecting the exit options and loading default settings.

To select an item on the menu bar, press the right or left arrow key on the keyboard until the desired item is highlighted.

The Main menu provides you an overview of the basic system information, and allows you to set the system date, time, language, and security settings.

System Date [Day MM/DD/YYYY]: Allows you to set the system date.

System Time [HH:MM:SS]: Allows you to set the system time.

3.3 Setup Submenu: Main Menu



3.4 Setup Submenu: Advanced

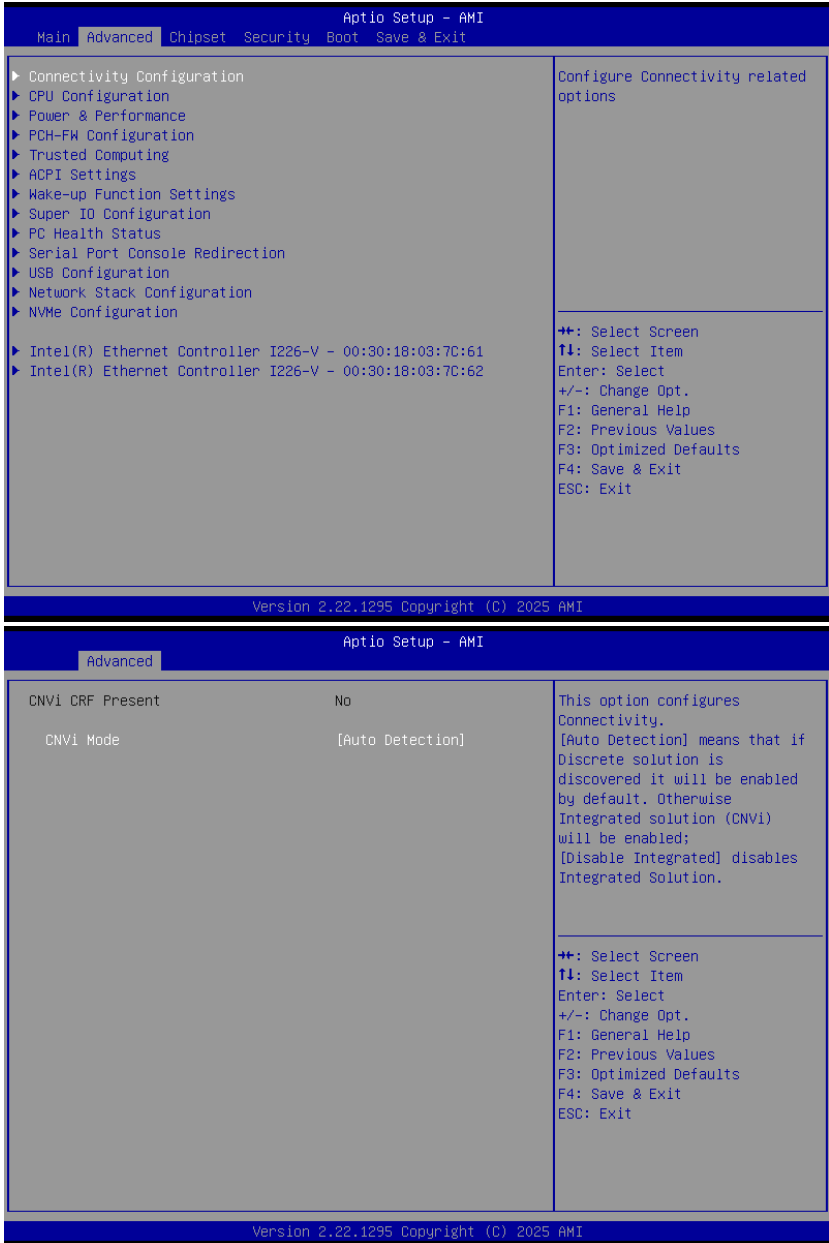

The Advanced menu items allow you to change the settings for the CPU and other system devices.



CAUTION! Be cautious when changing the settings of the Advanced menu items. Incorrect field values can cause the system to malfunction.

3.4.1 CPU Configuration

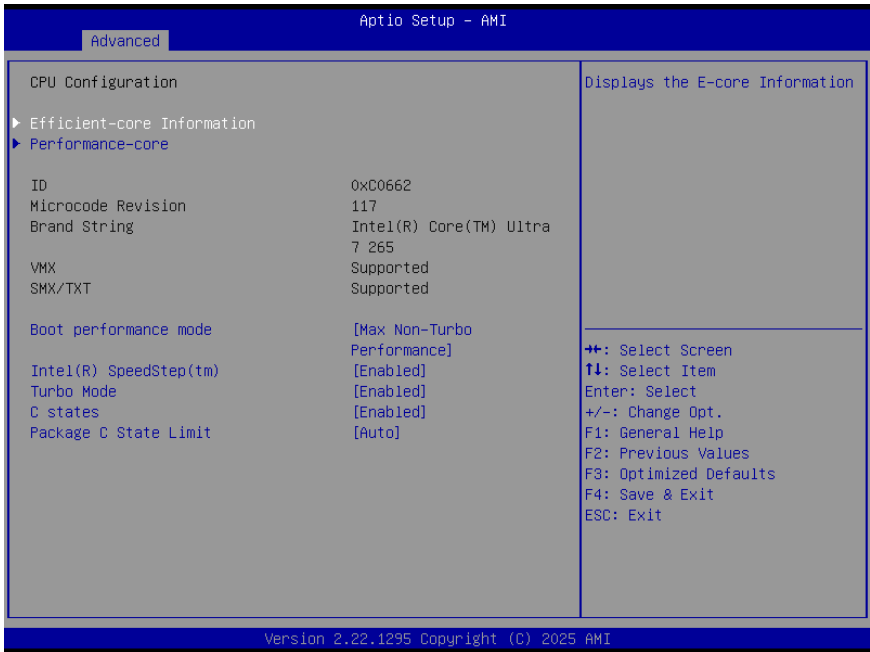

Options Summary

Boot Performance Mode	Max Non-Turbo Performance
	Min Non-Turbo Performance
	Turbo Performance
Use this item to select the performance state that the BIOS will set starting from the reset vector.	
Intel® SpeedStep™	Enabled
	Disabled
Allows more than two frequency ranges to be supported	

Options Summary

Turbo Mode	Enabled
	Disabled
Enable or Disable processor Turbo Mode. Requires Intel SpeedStep or Intel Speed Shift to be available and enabled.	
C States	Enabled
	Disabled
Enable or Disable CPU Power Management. Allows CPU to enter C states when it is not 100% utilized.	
Package C State Limit	C0/C1
	C2
	C3
	C6
	C7
	C7S
	C8
	C9
	C10
	CPU Default
	Auto
Set the maximum package C State Limit. "CPU Default" leaves it at the factory value; "Auto" initializes to the deepest available package C State Limit.	



Important: The items shown in the submenu may be different depending on the type of CPU installed.

Efficient-core Information

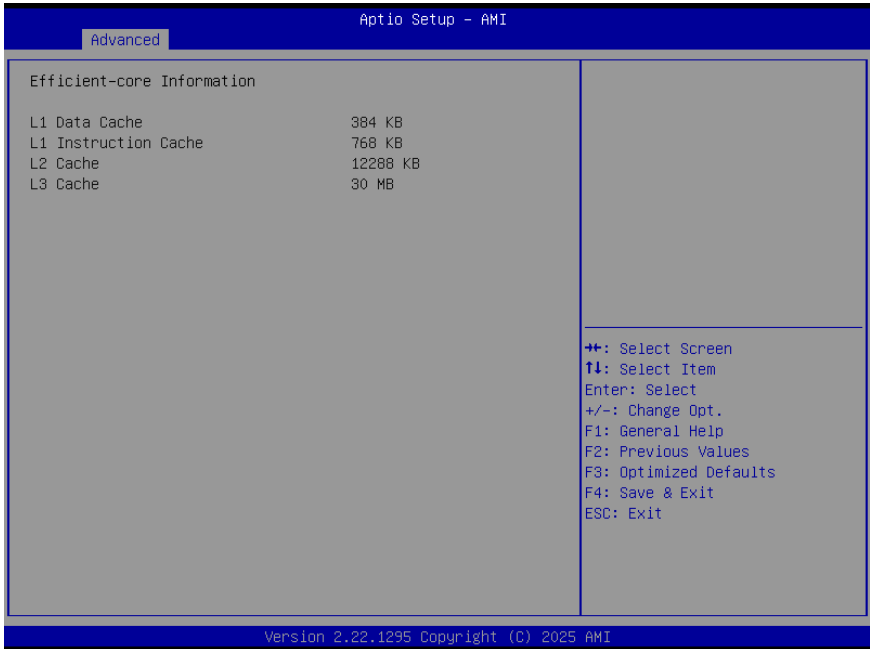

Press [Enter] to make settings for the following sub-items:

L1 Date Cache/L1 Instruction Cache/L2 Cache/L3 Cache

Performance-core Information

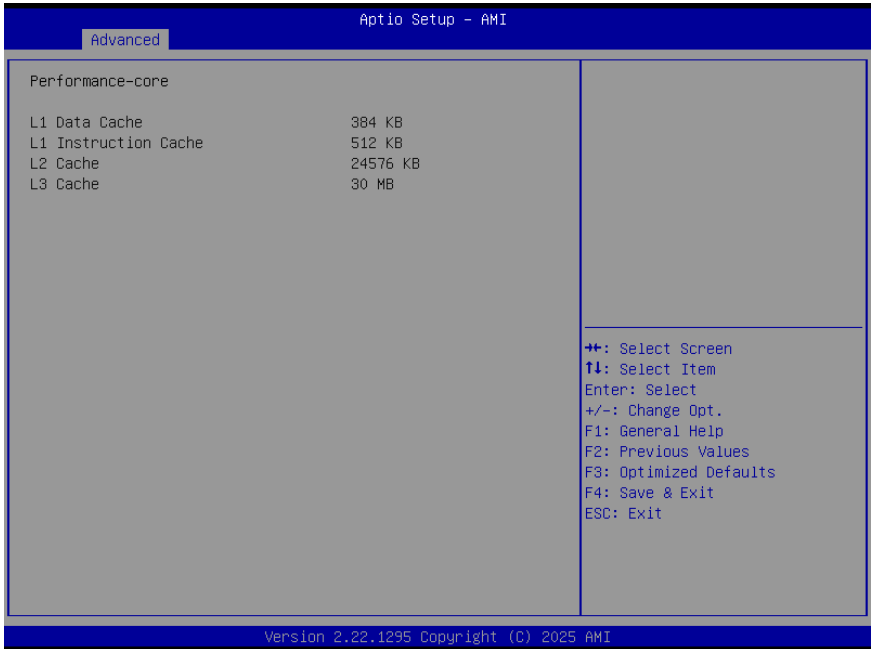

Press [Enter] to make settings for the following sub-items:

L1 Date Cache/L1 Instruction Cache/L2 Cache/L3 Cache

3.4.2 Power & Performance

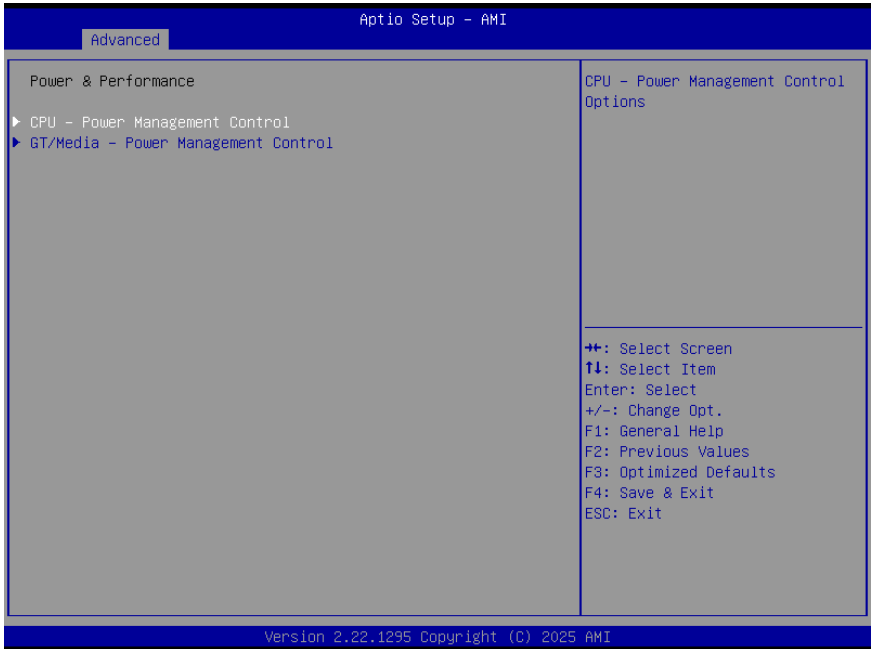

3.4.2.1 CPU – Power Management Control

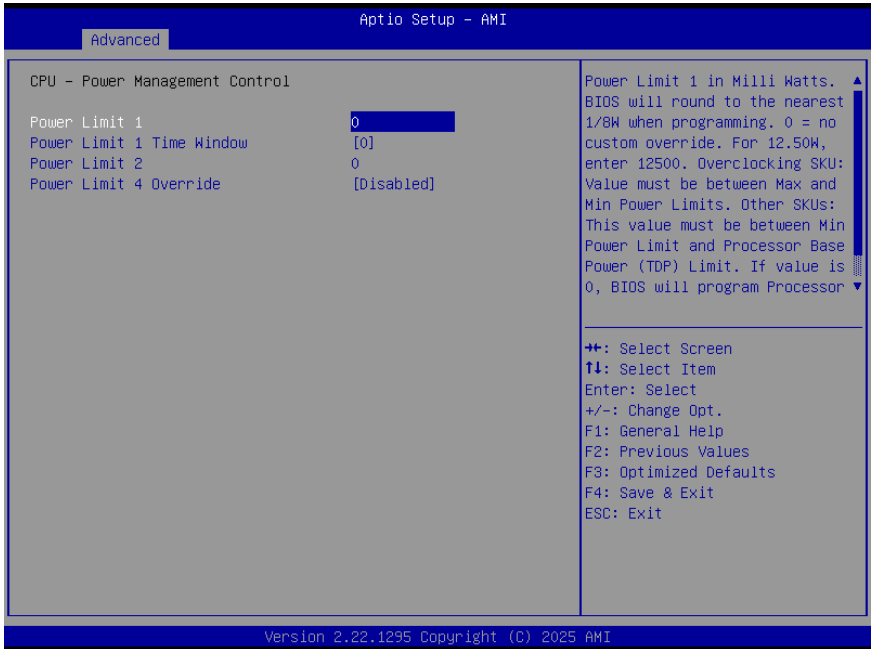

Options Summary

Power Limit 1	0
<p>Set Power Limit 1 value in milliwatts. BIOS rounds the value to the nearest 1/8W when programming.</p> <p>A value of 0 means no custom override. For example, to set 12.50W, enter 12500.</p> <p>Overclocking SKU: Value must be between the minimum and maximum power limits defined by PACKAGE_POWER_SKU_MSR.</p> <p>Other SKUs: Value must be between the minimum power limit and the Processor Base Power (TDP) limit. If set to 0, BIOS programs the Processor Base Power (TDP) value.</p>	
Power Limit 1 Time Window	0
	1
	2
	3
	4
	5
	6

Options Summary

Power Limit 1 Time Window (Cont.)

7
8
10
12
14
16
20
24
28
32
40
48
56
64
80
96
112
128

Set Power Limit 1 Time Window value in seconds. Valid range is from 0 to 128 seconds. A value of 0 uses the default time window (28 seconds for Mobile processors and 8 seconds for Desktop processors).
Defines the time window during which the Processor Base Power (TDP) value is maintained.

Power Limit 2

0

Set Power Limit 2 value in milliwatts. BIOS rounds the value to the nearest 1/8W when programming.
A value of 0 means no custom override. For example, to set 12.50W, enter 12500.
Processor applies internal control policies to ensure package power does not exceed this limit.

Power Limit 4 Override

Disabled
Enabled

Enable or Disable Power Limit 4 override.
When disabled, BIOS leaves the default Power Limit values unchanged.

3.4.2.2 GT/Media – Power Management Control

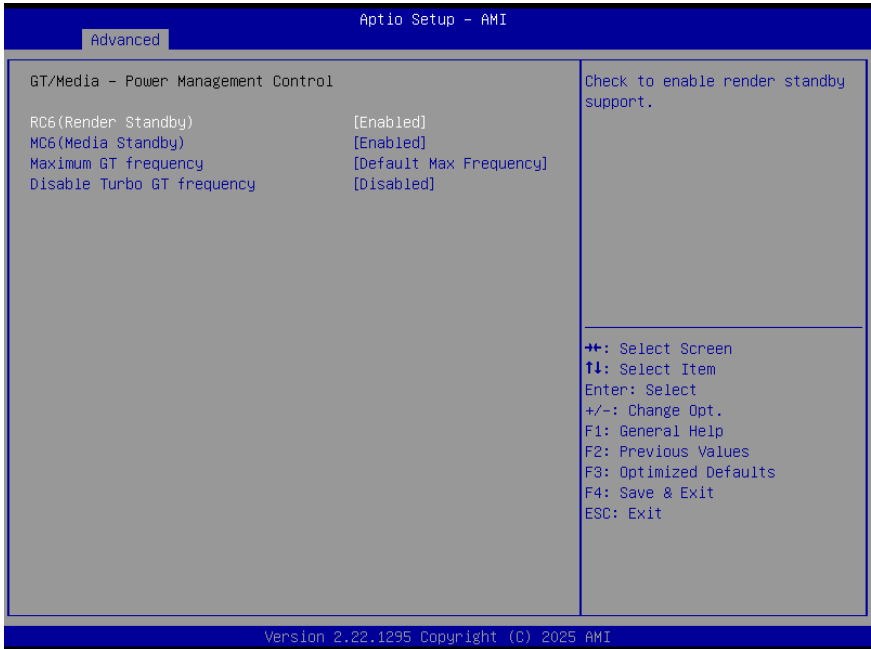

Options Summary	
RC6 (Render Standby)	Enabled
	Disabled
Enable or Disable render standby support. When enabled, the graphics render engine may enter RC6 low-power state when idle to reduce power consumption.	
RC6 (Media Standby)	Enabled
	Disabled
Enable or Disable media standby support. When enabled, the graphics media engine may enter RC6 low-power state when idle to reduce power consumption.	
RC6 (Media Standby)	Default Max Frequency
	100MHz
	150MHz
	200MHz
	250MHz
	300MHz
	350MHz
	400MHz
450MHz	

Options Summary

RC6 (Media Standby)

500MHz

550MHz

600MHz

650MHz

700MHz

750MHz

800MHz

850MHz

900MHz

950MHz

1000MHz

1050MHz

1100MHz

1150MHz

1200MHz

Limit the maximum GT (graphics) frequency set by the user. Select a value between 100MHz (RPn) and 1200MHz (RP0). Values outside the supported range are clipped to the minimum or maximum frequency supported by the SKU.

Disable Turbo GT Frequency

Disabled

Enabled

When enabled, Turbo GT frequency is disabled and graphics frequency is limited. When disabled, GT frequency is not limited and turbo operation is allowed.

3.4.3 PCH-FW Configuration

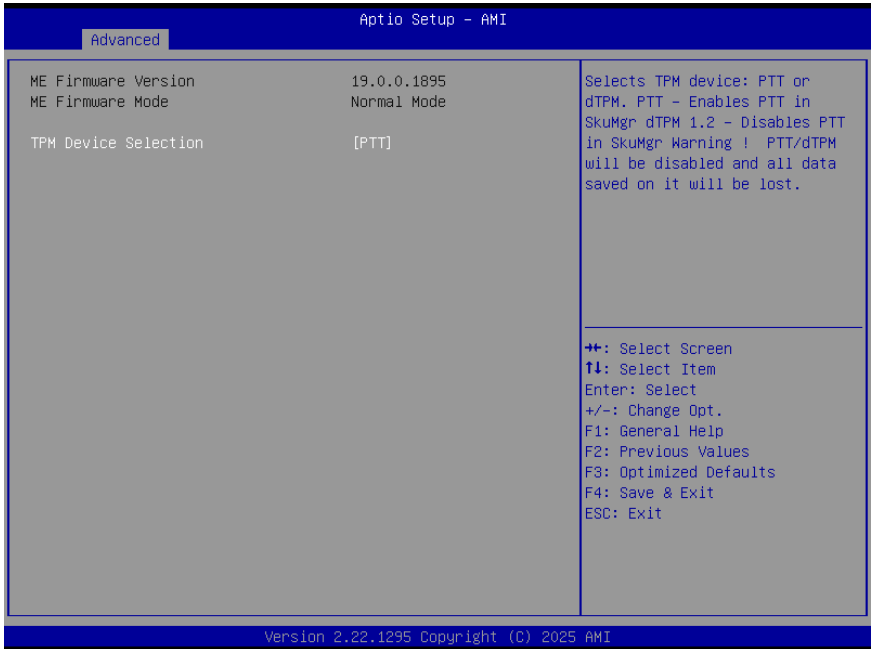

Options Summary	
TPM Device Selection	PTT
	dTPM
<p>PTT: Enables Intel® Platform Trust Technology (PTT) in SKuMgr. dTPM: Disables PTT and uses a discrete TPM 1.2 device. Warning: Switching between PTT and dTPM will disable the currently active TPM and all data stored in the TPM will be lost.</p>	

3.4.4 Trusted Computing

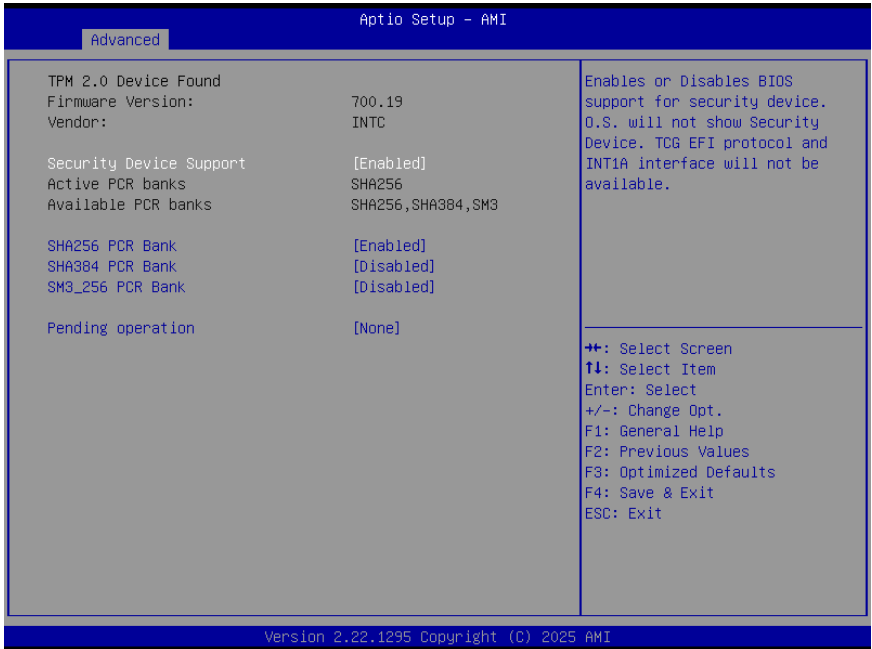

Options Summary	
Security Device Support	Enable Disable
Enables or Disables BIOS support for security device. O.S. will not show Security Device. TCG EFI protocol and INT1A interface will not be available.	
SHA256 PCR Bank	Enabled Disabled
Use this item to enable or disable SHA256 PCR Bank.	
SHA384 PCR Bank	Disabled Enabled
Use this item to enable or disable SHA384 PCR Bank.	
SM3_256 PCR Bank	Disabled Enabled
Use this item to enable or disable SM3_256 PCR Bank.	
Pending operation	None TPM Clear

Options Summary

Schedule an Operation for the Security Device.

NOTE: Your Computer will reboot during restart in order to change State of Security Device.

3.4.5 ACPI Settings



Options Summary

ACPI Sleep State	S3 (Suspend to RAM)
	Suspend Disabled

Use this item to select the highest ACPI sleep state the system will enter when the suspend button is pressed.

3.4.6 Wake-up Function Settings

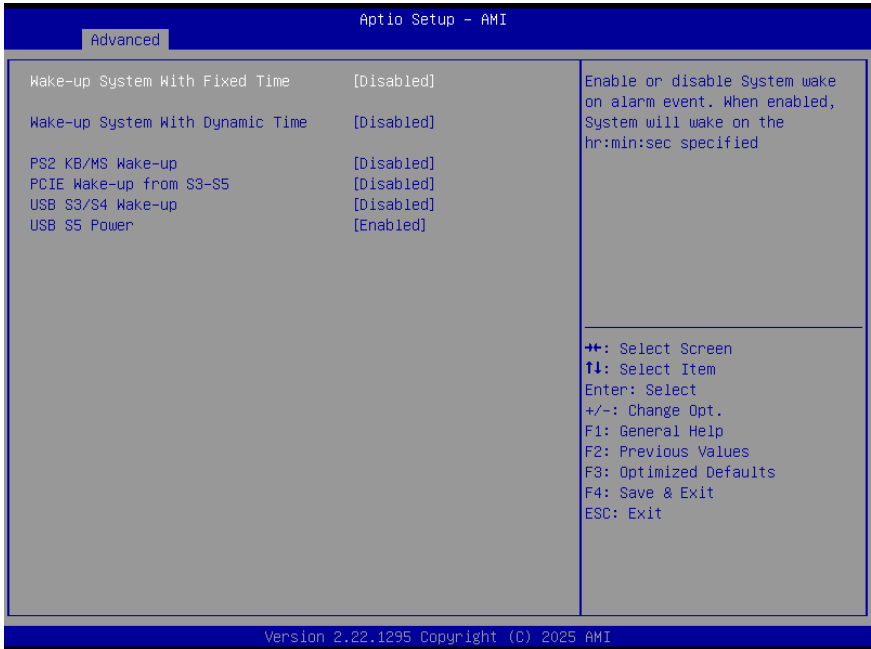

Options Summary	
Wake-up System With Fixed Time	Disabled
	Enabled
<p>Enable or Disable system wake-up by RTC alarm.</p> <p>When enabled, the system will wake at the specified time (hr:min:sec).</p> <p>Enabling this option allows the following sub-items to be configured:</p> <p>Wake-up Hour [0] – Default: 0. Select the hour (0–23) for system wake-up. Example: enter 3 for 3 AM, 15 for 3 PM.</p> <p>Wake-up Minute [0] – Default: 0. Select the minute (0–59) for system wake-up.</p> <p>Wake-up Second [0] – Default: 0. Select the second (0–59) for system wake-up.</p>	
Wake-up System With Dynamic Time	Disabled
	Enabled
<p>Enable or Disable system wake-up by RTC alarm using a dynamic time.</p> <p>The system will wake after the current time plus the specified minute increase.</p>	

Options Summary

This item is visible only when “Wake-up System With Fixed Time” is set to [Disabled].

Enabling this option allows the following sub-item to be configured:

Wake-up Minute Increase [1] – Default: 1. Select the number of minutes (1–60) to add to the current time for dynamic wake-up.

PS/2 KB/MS Wake-Up

Disabled

Enabled

Enable or Disable PS/2 keyboard/mouse wake-up from S3, S4, or S5 states.

Note: Disable ERP before activating this function in S4 or S5.

PCIe Wake-Up from S3–S5

Disabled

Enabled

Enable or Disable PCIe device wake-up from S3, S4, or S5 states.

USB S3/S4 Wake-Up

Disabled

Enabled

Enable or Disable USB wake-up support from S3 or S4 states.

Note: Disable ERP before activating this function.

USB S5 Power

Enabled

Disabled

Enable or Disable USB power after system shutdown (S5).

Note: Disable ERP before activating this function.

3.4.7 Super IO Configuration

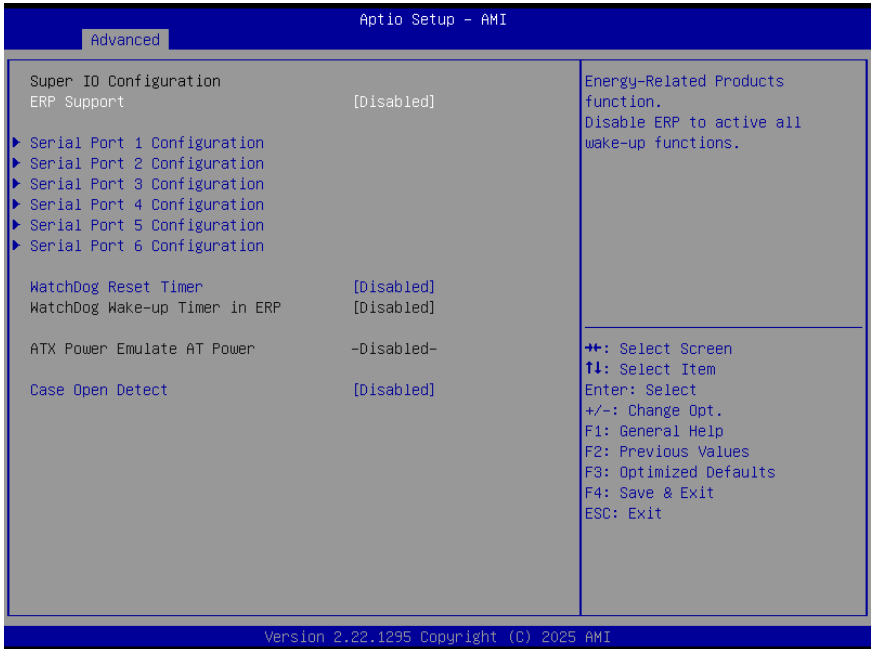

Options Summary	
ERP Support	Disabled
	Enabled
Enable or Disable ERP (Energy-Related Products) function. Disabling ERP is required to activate all wake-up functions.	

3.4.7.1 Serial Port 1 Configuration

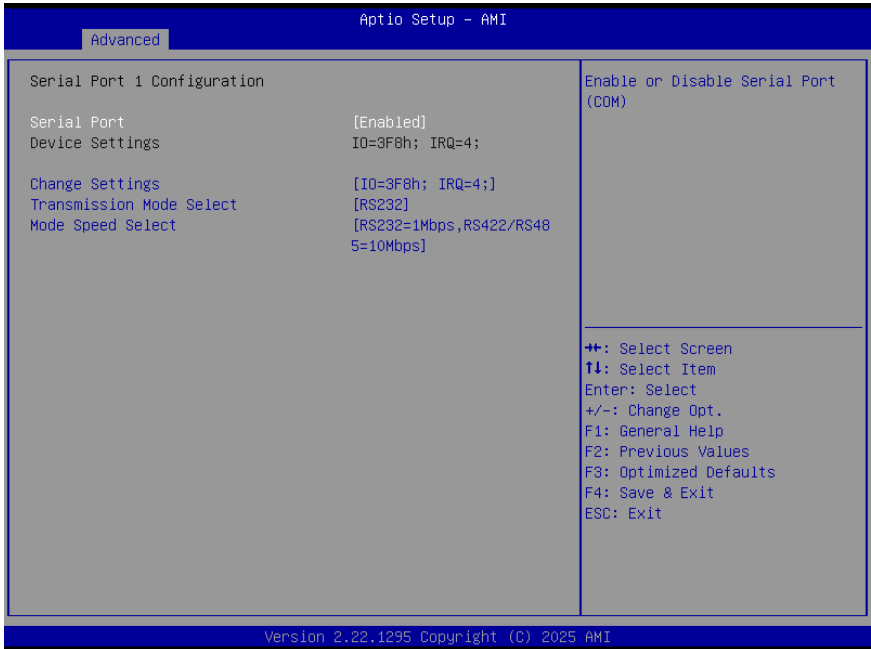

Options Summary	
Serial Port	Enabled
	Disabled
Use this item to enable or disable serial port (COM).	
Change Settings	IO=3F8h; IRQ=4
	IO=3F8h; IRQ=3,4,5,7,10,11;
	IO=2F8h; IRQ=3,4,5,7,10,11;
	IO=3E8h; IRQ=3,4,5,7,10,11;
	IO=2E8h; IRQ=3,4,5,7,10,11;
Use this item to select an optimal setting for super IO device.	
Transmission Mode Select	RS232
	RS422
	RS485
Mode Speed Select	RS232=1Mbps, RS422/RS485=10Mbps
	RS232/RS422/RS485=250Kbps

3.4.7.2 Serial Port 2 Configuration

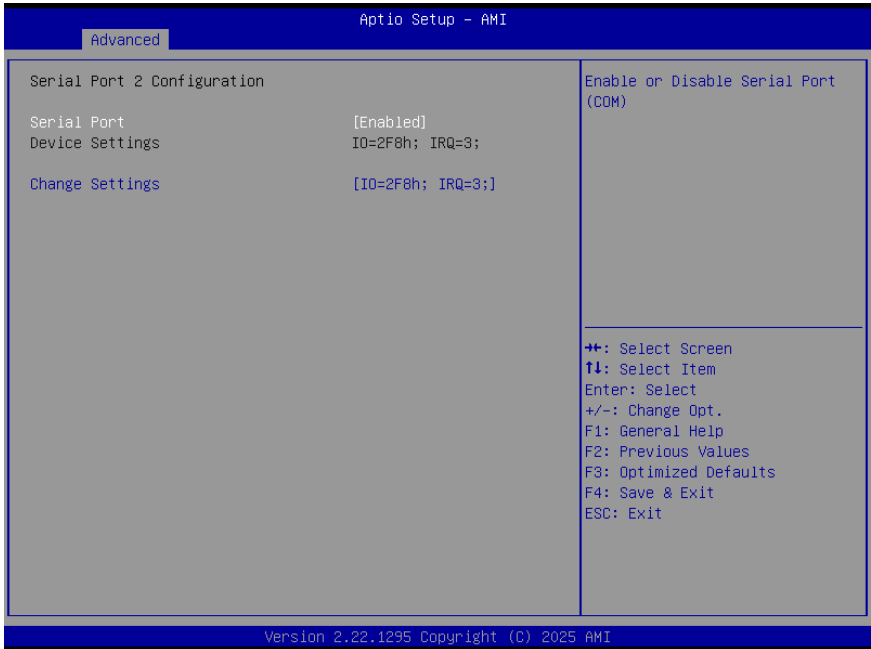

Options Summary	
Serial Port	Enabled
	Disabled
Use this item to enable or disable serial port (COM).	
Change Settings	IO=2F8h; IRQ=3;
	IO=3F8h; IRQ=3,4,5,7,10,11;
	IO=2F8h; IRQ=3,4,5,7,10,11;
	IO=3E8h; IRQ=3,4,5,7,10,11;
	IO=2E8h; IRQ=3,4,5,7,10,11;
Use this item to select an optimal setting for super IO device.	

3.4.7.3 Serial Port 3 Configuration

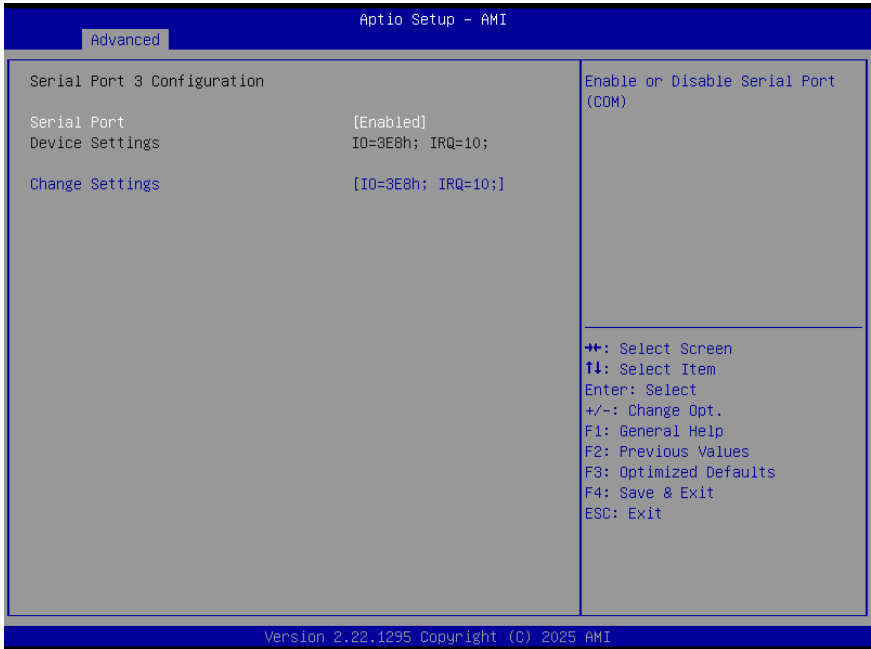

Options Summary	
Serial Port	Enabled
	Disabled
Use this item to enable or disable serial port (COM).	
Change Settings	IO=3F8h; IRQ=10;
	IO=3F8h; IRQ=3,4,5,7,10,11;
	IO=2F8h; IRQ=3,4,5,7,10,11;
	IO=3E8h; IRQ=3,4,5,7,10,11;
	IO=2E8h; IRQ=3,4,5,7,10,11;
	IO=3E0h; IRQ=3,4,5,7,10,11;
	IO=2E0h; IRQ=3,4,5,7,10,11;
Use this item to select an optimal setting for super IO device.	

3.4.7.4 Serial Port 4 Configuration

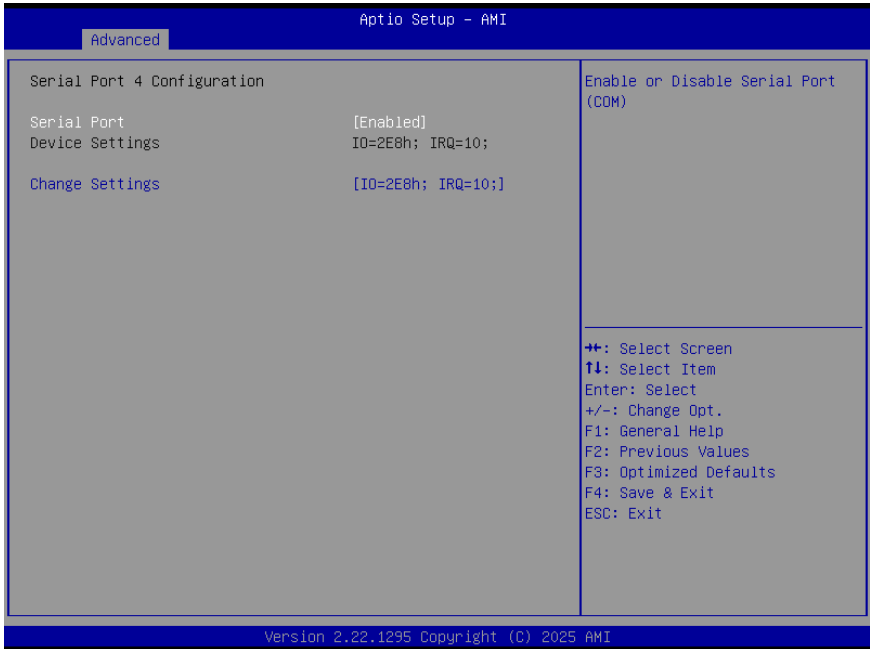

Options Summary	
Serial Port	Enabled
	Disabled
Use this item to enable or disable serial port (COM).	
Change Settings	IO=2E8h; IRQ=10;
	IO=3F8h; IRQ=3,4,5,7,10,11;
	IO=2F8h; IRQ=3,4,5,7,10,11;
	IO=3E8h; IRQ=3,4,5,7,10,11;
	IO=2E8h; IRQ=3,4,5,7,10,11;
	IO=3E0h; IRQ=3,4,5,7,10,11;
	IO=2E0h; IRQ=3,4,5,7,10,11;
Use this item to select an optimal setting for super IO device.	

3.4.7.5 Serial Port 5 Configuration

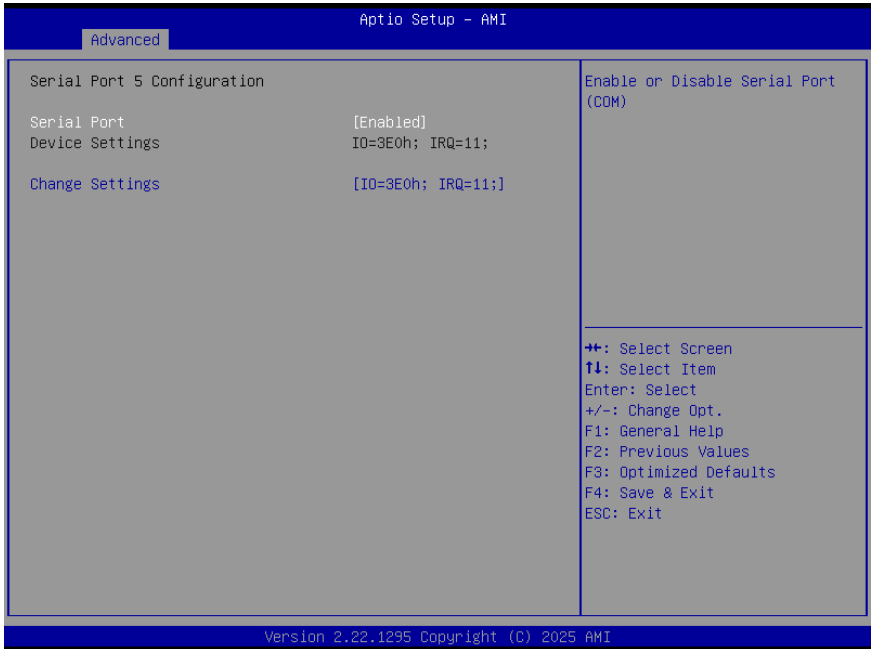

Options Summary	
Serial Port	Enabled
	Disabled
Use this item to enable or disable serial port (COM).	
Change Settings	IO=3E0h; IRQ=11;
	IO=3F8h; IRQ=3,4,5,7,10,11;
	IO=2F8h; IRQ=3,4,5,7,10,11;
	IO=3E8h; IRQ=3,4,5,7,10,11;
	IO=2E8h; IRQ=3,4,5,7,10,11;
	IO=3E0h; IRQ=3,4,5,7,10,11;
	IO=2E0h; IRQ=3,4,5,7,10,11;
Use this item to select an optimal setting for super IO device.	

3.4.7.6 Serial Port 6 Configuration

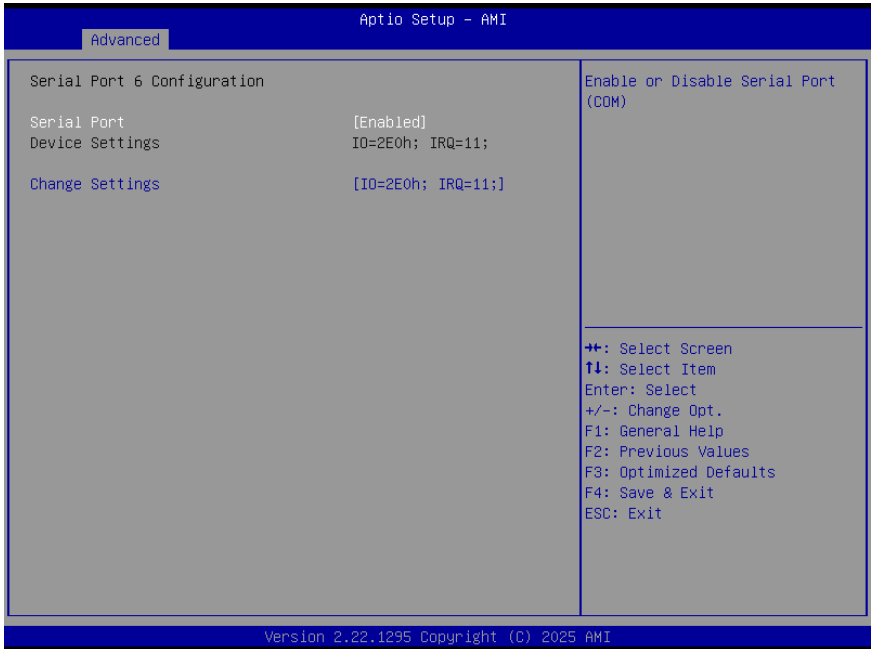

Options Summary	
Serial Port	Enabled
	Disabled
Use this item to enable or disable serial port (COM).	
Change Settings	IO=2E0h; IRQ=11
	IO=3F8h; IRQ=3,4,5,7,10,11;
	IO=2F8h; IRQ=3,4,5,7,10,11;
	IO=3E8h; IRQ=3,4,5,7,10,11;
	IO=2E8h; IRQ=3,4,5,7,10,11;
	IO=3E0h; IRQ=3,4,5,7,10,11;
	IO=2E0h; IRQ=3,4,5,7,10,11;
Use this item to select an optimal setting for super IO device.	

3.4.8 PC Health Status

The screenshot displays the 'Advanced' menu of the Aptio Setup - AMI BIOS. The 'PC Health Status' section is expanded to show 'SmartFAN Configuration'. The configuration details include:

CPU Temperature	: +39 C
System Temperature	: +35 C
CPUFAN Speed	: 2521 RPM
SYSFAN1 Speed	: 0 RPM
SYSFAN2 Speed	: 0 RPM
VCCORE	: +0.968 V
VCC	: +4.943 V
+12V	: +12.056 V
VDIMM	: +1.093 V
VCC3V	: +3.280 V
VSB3V	: +3.344 V
VBAT	: +3.136 V

Navigation instructions are listed on the right side of the screen:

- ⇧⇧: Select Screen
- ⇧⇩: Select Item
- Enter: Select
- +/-: Change Opt.
- F1: General Help
- F2: Previous Values
- F3: Optimized Defaults
- F4: Save & Exit
- ESC: Exit

Version 2.22.1295 Copyright (C) 2025 AMI

3.4.8.1 SmartFAN Configuration

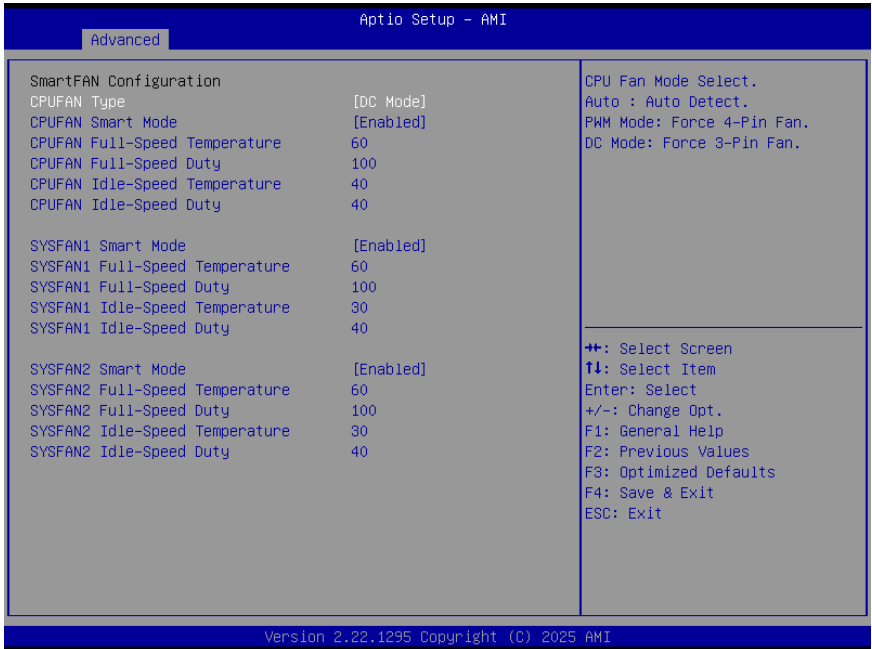

Options Summary	
CPUFAN Type	PWM Mode
	DC Mode
Selects CPU fan mode.	
PWM Mode: Forces 4-pin fan operation.	
DC Mode: Forces 3-pin fan operation.	
CPUFAN1 Smart Mode	Disabled
	Enabled
CPUFAN Full-Speed Temperature	60
CPUFAN Full-Speed Duty	100
Fan will run at full speed when above this pre-set duty.	
CPUFAN Idle-Speed Temperature	40
Fan will run at idle speed when below this pre-set temperature.	
CPUFAN Idle-Speed Duty	40
Fan will run at idle speed when below this pre-set duty.	
SYSFAN1 Smart Mode / SYSFAN2 Smart Mode	Disabled
	Enabled

Options Summary	
SYSFAN1/SYSFAN2 Full-Speed Temperature	60
SYSFAN1/SYSFAN2 Full-Speed Duty	100
Fan will run at full speed when above this pre-set duty.	
CPUFAN Idle-Speed Temperature	30
Fan will run at idle speed when below this pre-set temperature.	
CPUFAN Idle-Speed Duty	40
Fan will run at idle speed when below this pre-set duty.	

3.4.9 Serial Port Console Redirection



Options Summary	
Console Redirection	Disabled
	Enabled
Enable or Disable Console Redirection. When set to Enabled, additional configuration options become available in the Console Redirection Settings screen.	

3.4.9.1 Console Redirection EMS

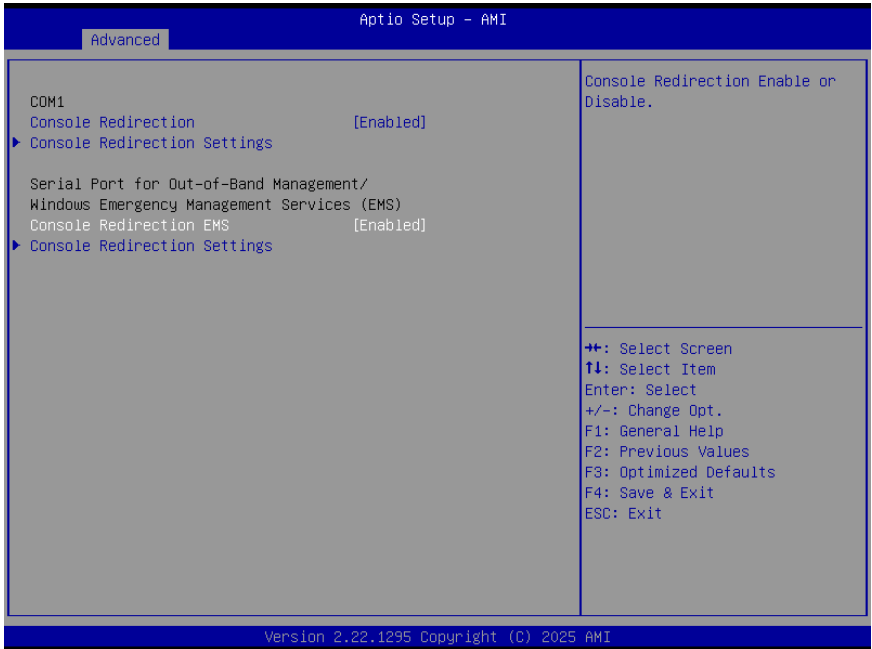

Options Summary	
Console Redirection EMS	Disabled
	Enabled
Enable or Disable Console Redirection EMS. When set to Enabled, additional configuration options become available in the Console Redirection Settings screen.	

3.4.9.2 Console Redirection Settings



Options Summary	
Terminal Type	ANSI
	VT100
	VT100Plus
	VT-UTF8
Selects the terminal emulation type. ANSI: Extended ASCII character set. VT100: ASCII character set. VT100Plus: Extends VT100 to support color, function keys, and additional features. VT-UTF8: Uses UTF-8 encoding to map Unicode characters to one or more bytes.	
Bits per second	9600
	19200
	57600
	115200
	230400
	460800
	921600
Use this item to select serial port transmission speed. The speed must be matched on	

Options Summary

the other side. Long or noisy lines may require lower speeds.

Data Bits	7
	8
Parity	None
	Even
	Odd
	Mark
	Space

Selects the parity mode used for serial data transmission to detect transmission errors.

None: No parity bit is sent.

Even: Parity bit is set to 0 when the number of logical 1s in the data bits is even.

Odd: Parity bit is set to 0 when the number of logical 1s in the data bits is odd.

Mark: Parity bit is always set to 1.

Space: Parity bit is always set to 0.

Note: **Mark** and **Space** parity do not provide error detection and may be used as an additional data bit.

Stop Bits	1
	2

Stop bits indicate the end of a serial data packet. (A start bit indicates the beginning). The standard setting is 1 stop bit. Communication with slow devices may require more than 1 stop bit.

Flow Control	None
	Hardware RTS/CTS

Flow control can prevent data loss from buffer overflow. When sending data, if the receiving buffers are full, a "stop" signal can be sent to stop the data flow. Once the buffers are empty, a "start" signal can be sent to re-start the flow. Hardware flow control uses two wires to send start/stop signals.

VT-UTF8 Combo Key Support	Disabled
	Enabled

Use this item to enable VT-UTF8 Combination Key Support for ANSI/VT100 terminals.

Recorder Mode	Disabled
	Enabled

With this mode enabled only text will be sent. This is to capture Terminal data.

Resolution 100x31	Disabled
	Enabled

Use this item to enable or disable extended terminal resolution.

Putty KeyPad	VT100
	LINUX
	XTERMR6
	SCO
	ESCN

Options Summary

Putty KeyPad (Cont.)

VT400

Use this item to enable or disable extended terminal resolution.

3.4.9.3 Console Redirection Settings (Out-of-Band Mgmt Port)

The screenshot shows the 'Advanced' section of the 'Aptio Setup - AMI' utility. The 'Out-of-Band Mgmt Port' settings are displayed as follows:

Out-of-Band Mgmt Port	COM1	VT-UTF8 is the preferred terminal type for out-of-band management. The next best choice is VT100+ and then VT100. See above, in Console Redirection Settings page, for more Help with Terminal Type/Emulation.
Terminal Type EMS	[VT-UTF8]	
Bits per second EMS	[115200]	
Flow Control EMS	[None]	
Data Bits EMS	8	
Parity EMS	None	
Stop Bits EMS	1	

Navigation instructions:

- ++: Select Screen
- F4: Select Item
- Enter: Select
- +/-: Change Opt.
- F1: General Help
- F2: Previous Values
- F3: Optimized Defaults
- F4: Save & Exit
- ESC: Exit

Version 2.22.1295 Copyright (C) 2025 AMI

Options Summary

Terminal Type EMS

VT100

VT100Plus

VT-UTF8

ANSI

Specifies the terminal emulation type used for data exchange between the host computer and the remote system. Both systems must use the same or compatible settings.

Bits per second EMS

9600

19200

57600

115200

230400

Options Summary	
Bits per second EMS (Cont.)	460800
	921600
Use this item to select serial port transmission speed. The speed must be matched on the other side. Long or noisy lines may require lower speeds.	
Flow Control EMS	None
	Hardware RTS/CTS
	Software Xon/Xoff
Flow control can prevent data loss from buffer overflow. When sending data, if the receiving buffers are full, a "stop" signal can be sent to stop the data flow. Once the buffers are empty, a "start" signal can be sent to re-start the flow. Hardware flow control uses two wires to send start/stop signals.	
Data Bits EMS	8
Parity EMS	None
Stop Bits EMS	1

3.4.10 USB Configuration

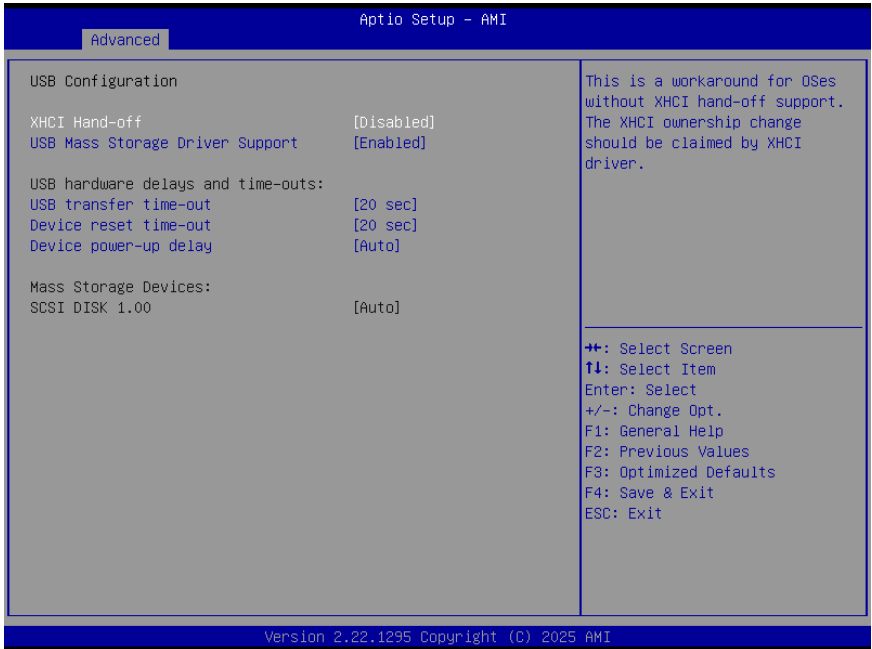

Options Summary	
XHCI Hand-off	Disabled
	Enabled
This is a workaround for OSES without XHCI hand-off support. The XHCI ownership change should be claimed by XHCI driver.	
USB Mass Storage Driver Support	Disabled
	Enabled
Use this item to enable or disable USB Mass storage driver support.	
USB Transfer time-out	1 sec
	5 sec
	10 sec
	20 sec
Use this item to set the time-out value for control, bulk, and interrupt transfers	
Device reset time-out	10 sec
	20 sec
	30 sec
	40 sec
Use this item to set USB mass storage device start unit command time-out.	

Options Summary

Device power-up delay	Auto
	Manual

Use this item to set maximum time the device will take before it properly reports itself to the host controller. 'Auto' uses default value: for a root port it is 100 ms, for a hub port the delay is taken from hub descriptor.

3.4.11 Network Stack Configuration



Options Summary

Network Stack	Disabled
	Enabled

Enable or disable UEFI Network Stack.

When **Network Stack** set as **[Enabled]**

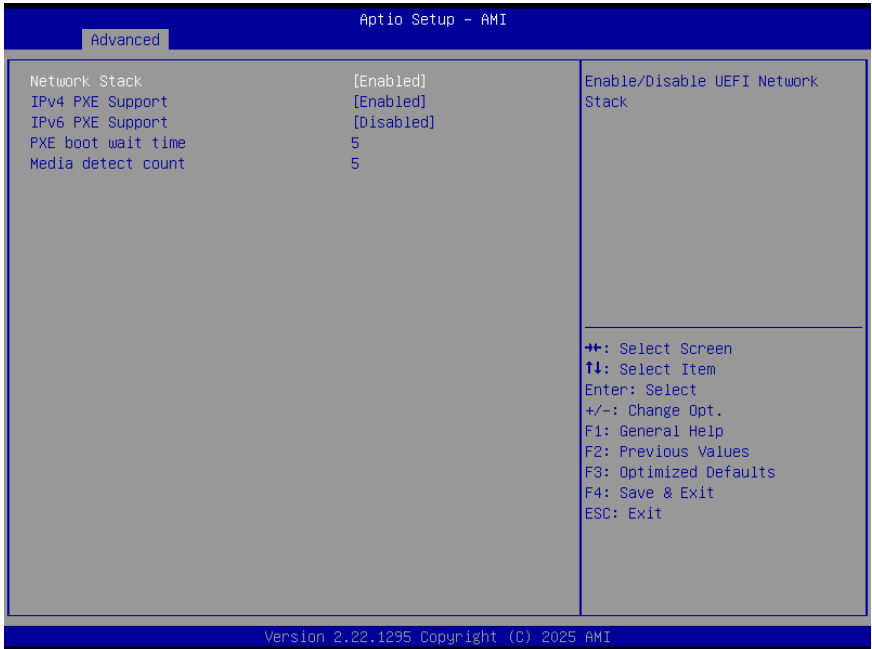

Options Summary	
IPv4 PXE Support	Enabled
	Disabled
Enables or disables IPv4 PXE boot support.	
IPv6 PXE Support	Disabled
	Enabled
Enables or disables IPv6 PXE boot support.	
PXE Boot Wait Time	5
Use either [+] or [-] or numeric keys to set the value. PXE boot wait time. Range: 0-255 seconds	
Media Detect Count	5
Use this item to set number of times presence of media will be checked. Use either [+] or [-] or numeric keys to set the value. Range: 0-255 seconds	

3.4.12 NVMe Configuration

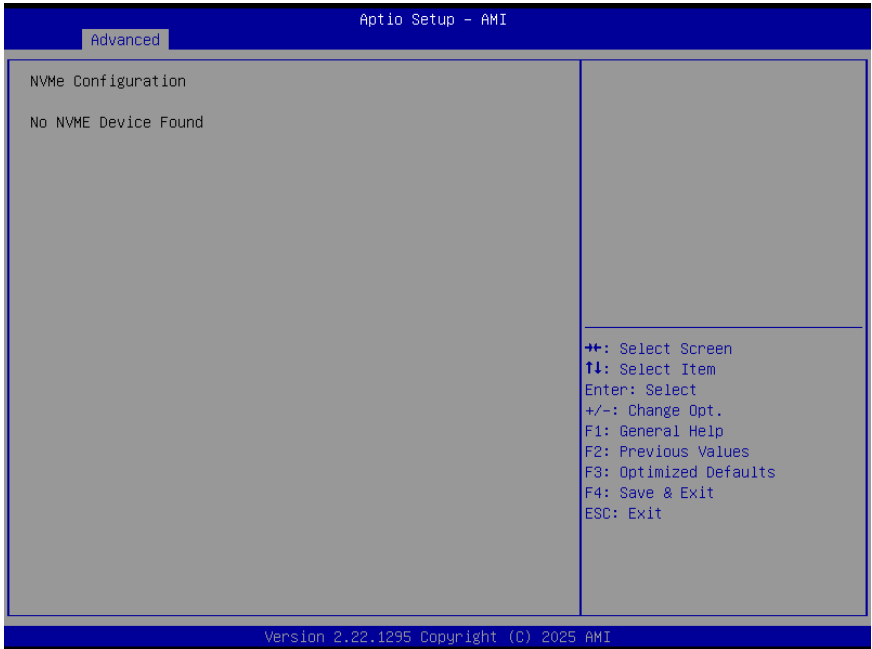

3.4.12.1 Intel (R) Ethernet Controller I226-LM

The screenshot shows the BIOS configuration screen for the Intel (R) Ethernet Controller I226-LM. The interface is titled "Aptio Setup - AMI" and is currently on the "Advanced" tab. The configuration details are as follows:

UEFI Driver	Intel(R) 2.5G Ethernet Controller 0.10.04
Device Name	Intel(R) Ethernet Controller I226-V
Link Status	[Disconnected]
MAC Address	00:30:18:03:7C:61

Navigation and function keys are listed in the bottom right corner:

- ⇐: Select Screen
- ⇓: Select Item
- Enter: Select
- +/-: Change Opt.
- F1: General Help
- F2: Previous Values
- F3: Optimized Defaults
- F4: Save & Exit
- ESC: Exit

Version 2.22.1295 Copyright (C) 2025 AMI

3.4.12.2 Intel (R) Ethernet Controller I226-V

Aptio Setup - AMI

Advanced

UEFI Driver	Intel(R) 2.5G Ethernet Controller 0.10.04
Device Name	Intel(R) Ethernet Controller I226-V
Link Status	[Disconnected]
MAC Address	00:30:18:03:7C:62

++: Select Screen
↑↓: Select Item
Enter: Select
+/-: Change Opt.
F1: General Help
F2: Previous Values
F3: Optimized Defaults
F4: Save & Exit
ESC: Exit

Version 2.22.1295 Copyright (C) 2025 AMI

3.5 Setup Submenu: Chipset



The Chipset menu items allow you to change the settings for the chipset.

3.5.1 System Agent (SA) Configuration

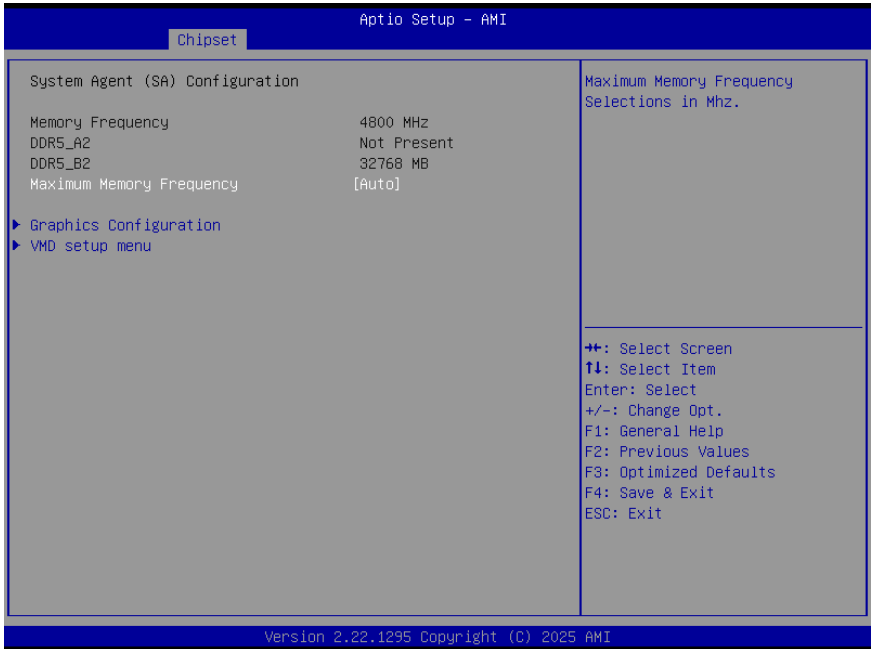

Options Summary	
Maximum Memory Frequency	Auto
	4000
	4400
	4800
	5200
	5600
	6000
	6400
Use this item to Maximum Memory Frequency selections in Mhz.	

3.5.2 Graphics Configuration

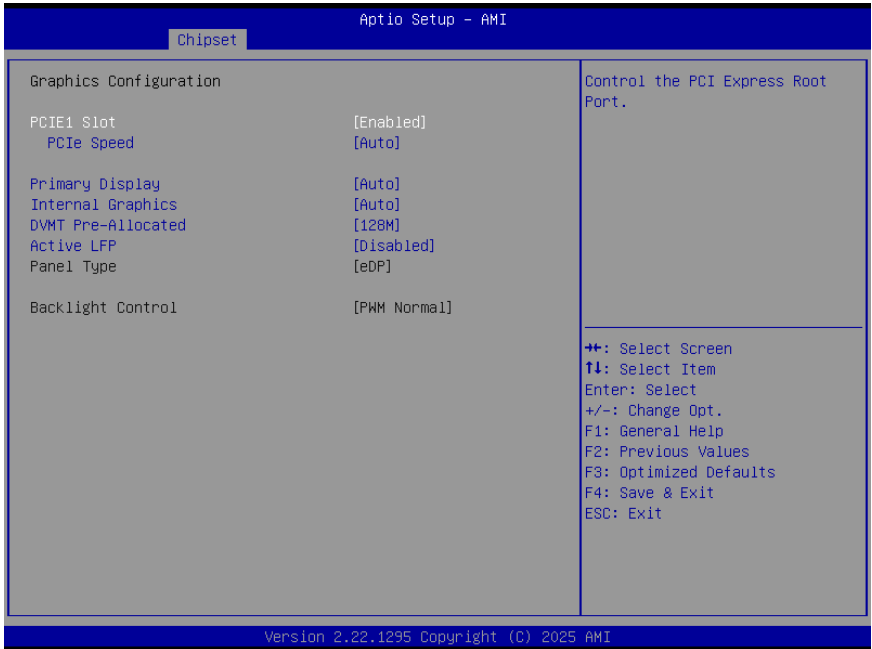

Options Summary	
PCIE1 Slot	Enabled
	Disabled
Use this item to control the PCI Express root port.	
PCie Speed	Auto
	Gen1
	Gen2
	Gen3
	Gen4
	Gen5
PCIE1 Slot Lane Select	X16
	X8/X8
Primary Display	Auto
	IGFX
Use this item to select which graphics device should be primary display	
Internal Graphics	Auto
	Disabled
	Enabled

Options Summary

Use this item to keep IGFX enabled based on the setup options.

DVMT Pre-Allocated

32M

64M

96M

128M

Use this item to select DVMT 5.0 Pre-Allocated (Fixed) graphics memory size used by the internal graphics device

Active LFP

Enabled

Disabled

Use this item to select the Active LFP Configuration.

Panel Type

1024x600 1ch 18-bit

1024x768 1ch 18-bit

1024x768 1ch 24-bit

1280x800 1ch 18-bit

1280x800 1ch 24-bit

1366x768 1ch 18-bit

1366x768 1ch 24-bit

1440x900 2ch 18-bit

1440x900 2ch 24-bit

1280x1024 2ch 24-bit

1680x1050 2ch 24-bit

1920x1080 2ch 24-bit

eDP

Backlight Control

PWM Inverted

PWM Normal

Use this item to make back light control setting.

3.5.3 VMD Setup Menu

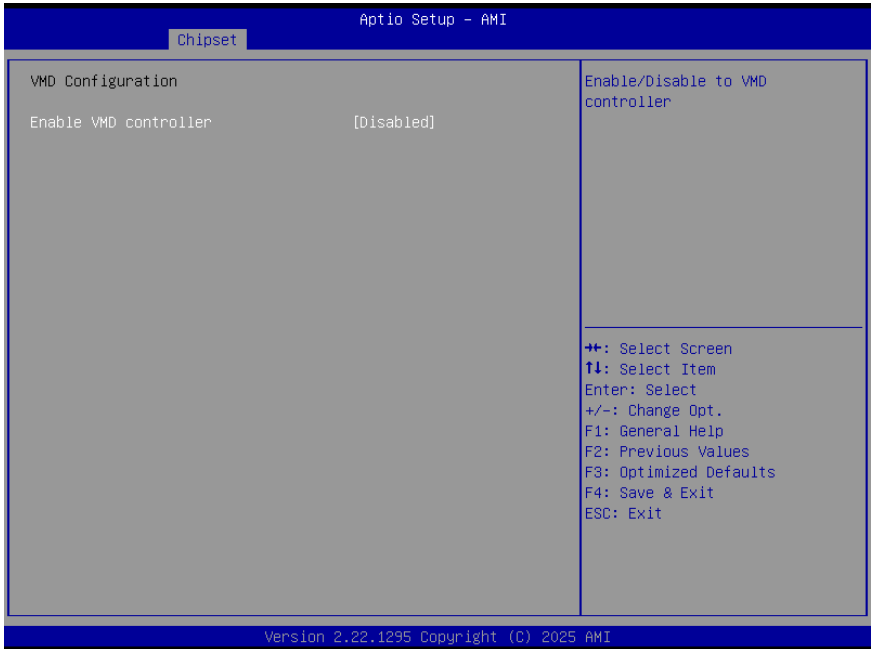

Options Summary	
Enable VMD controller	Disabled
	Enabled
Use this item to enable/disable to VMD controller.	

3.5.3.1 VMD Configuration

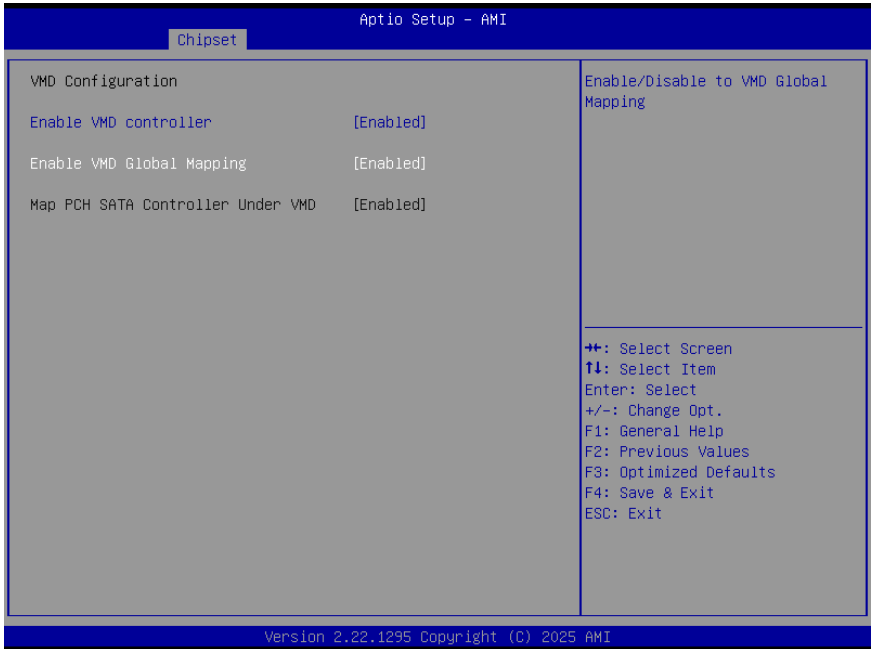

Options Summary	
Enable VMD Global Mapping	Enabled
	Disabled
Use this item to enable/disable to VMD global mapping.	
Map PCH SATA Controller Under VMD	Enabled
	Disabled
Use this item to Map/UnMap this root port to VMD	

3.5.4 PCH-IO Configuration



Options Summary	
HD Audio	Enabled
	Disabled
This item controls detection of the HD-Audio device.	
System State After Power Failure	Always On
	Always Off
	Former State
Use this item to specify what state to go to when power is re-applied after a power failure (G3 state)	

3.5.4.1 SATA Controller(s)

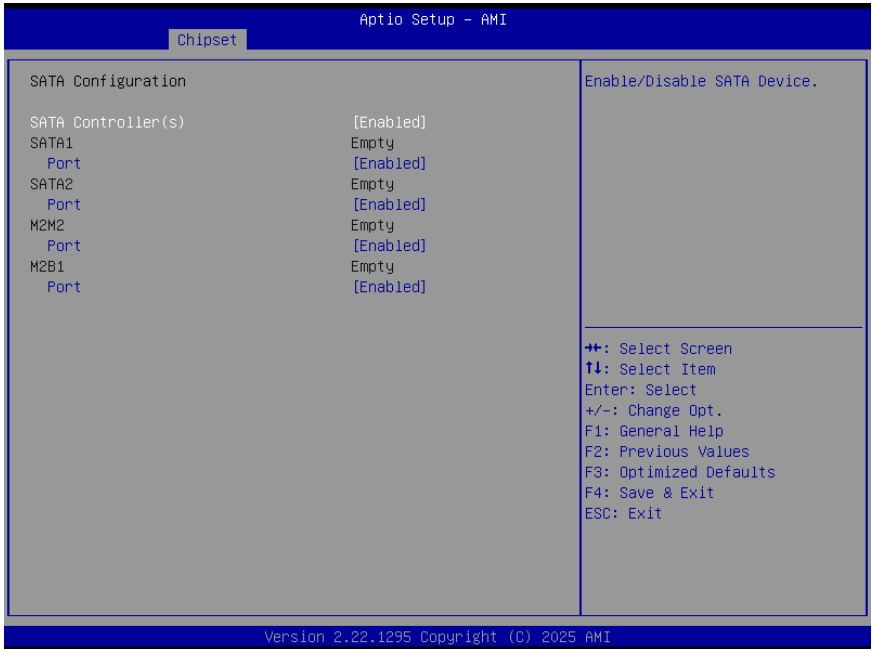

Options Summary	
SATA1	Enabled
	Disabled
Enable/Disable SATA Port.	
SATA2	Enabled
	Disabled
Enable/Disable SATA Port.	
M2M2	Enabled
	Disabled
Enable/Disable SATA Port.	
M2B1	Enabled
	Disabled
Enable/Disable SATA Port.	

3.6 Setup Submenu: Security

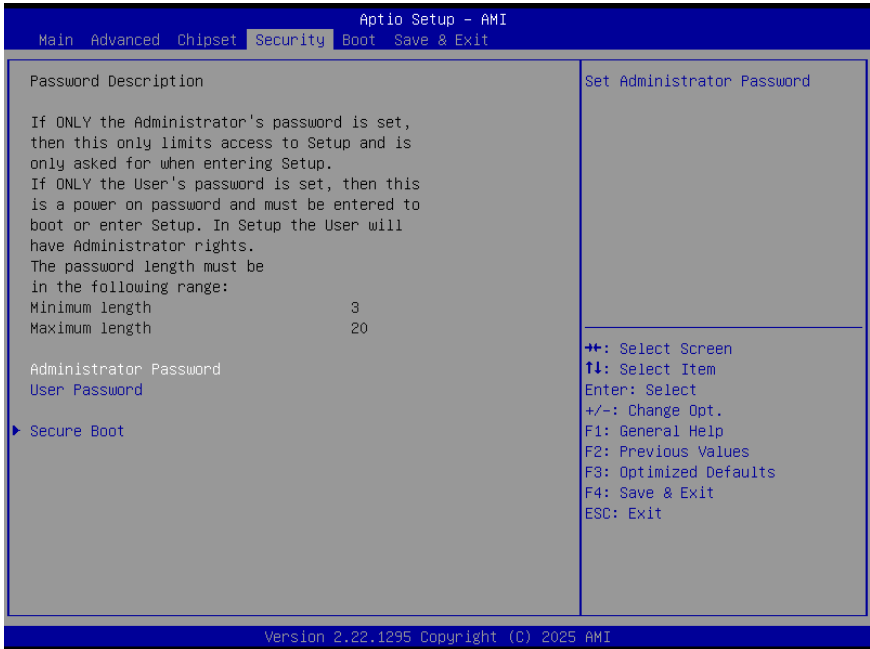

Administrator Password

If you have set an administrator password, we recommend that you enter the administrator password for accessing the system. Otherwise, you might be able to see or change only selected fields in the BIOS setup program.

To set an administrator password:

- 1 Select the **Administrator Password** item and press <Enter>.
- 2 From the **Create New Password** box, key in a password, then press <Enter>.
- 3 Confirm the password when prompted.

To change an administrator password:

- 1 Select the **Administrator Password** item and press <Enter>.
- 2 From the **Enter Current Password** box, key in the current password, then press <Enter>.
- 3 From the **Create New Password** box, key in a new password, then press <Enter>
- 4 Confirm the password when prompted.

To clear the administrator password, follow the same steps as in changing an administrator password, but press <Enter> when prompted to create/confirm the password. After you clear the password, the **Administrator Password** item on top of the screen shows **Not Installed**.

User Password

If you have set a user password, you must enter the user password for accessing the system. The **User Password** item on top of the screen shows the default **Not Installed**. After you set a password, this item shows **Installed**.

To set a user password:

- 1 Select the **User Password** item and press <Enter>.
- 2 From the **Create New Password** box, key in a password, then press <Enter>.
- 3 Confirm the password when prompted.

To change a user password:

- 1 Select the **User Password** item and press <Enter>.
- 2 From the **Enter Current Password** box, key in the current password, then press <Enter>.
- 3 From the **Create New Password** box, key in a new password, then press <Enter>
- 4 Confirm the password when prompted.

To clear the user password, follow the same steps as in changing a user password, but press <Enter> when prompted to create/confirm the password. After you clear the password, the **User Password** item on top of the screen shows **Not Installed**.

3.6.1 Secure Boot

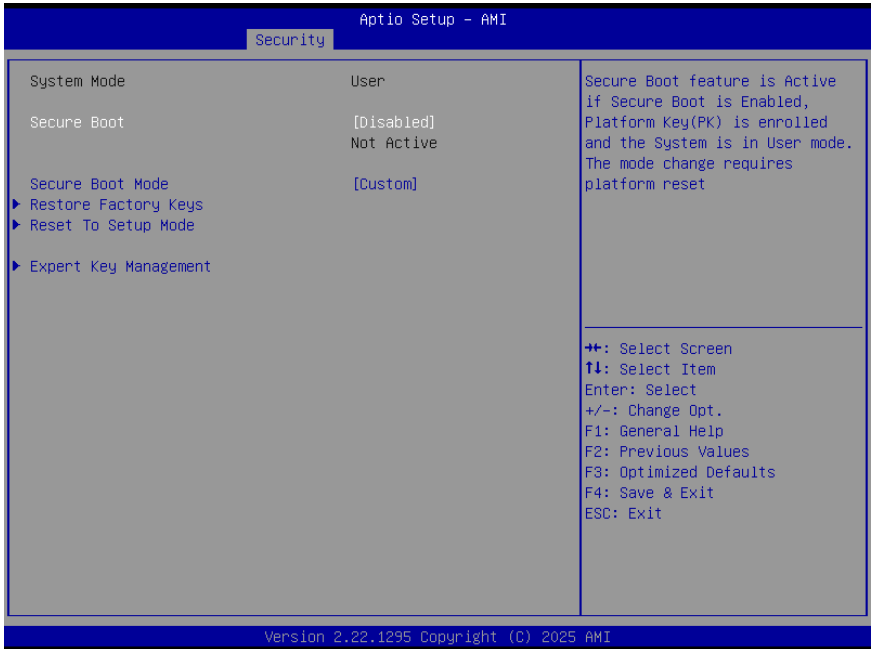

Options Summary	
Secure Boot	Disabled
	Enabled
Secure Boot feature is Active if Secure Boot is Enabled, Platform Key (PK) is enrolled and the System is in User mode. The mode change requires platform reset	
Secure Boot Status	Not Active
	Active
Displays the current Secure Boot state.	
Secure Boot Mode	Custom
	Standard
Set UEFI Secure Boot Mode to Standard mode or Custom mode. This change is effective after save. After reset, this mode will return to Standard mode. In Custom mode, Secure Boot Policy variables can be configured by a physically present user without full authentication.	

3.6.2 Key Management



Options Summary

Factory Key Provision	Enabled
	Disabled
Install factory default Secure Boot keys after the platform reset and while the System is in Setup mode.	

Restore Factory Keys

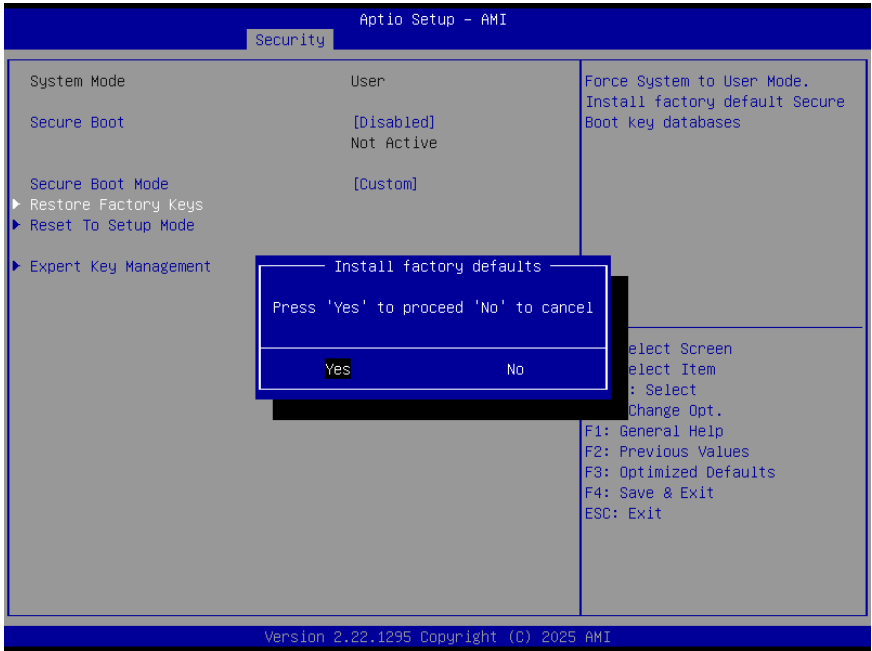

Options Summary

Install factory defaults	Yes
	No
Force System to User Mode. Install factory default Secure Boot key databases.	

Reset To Setup Mode

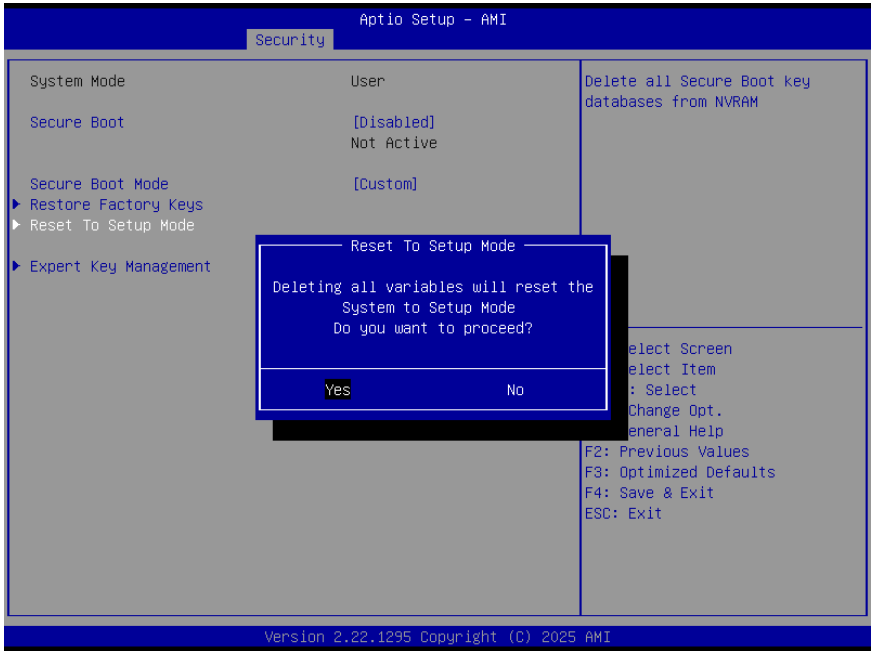

Options Summary

Install factory defaults	Yes
	No
Delete all Secure Boot key databases from NVRAM.	

Enroll EFI Image

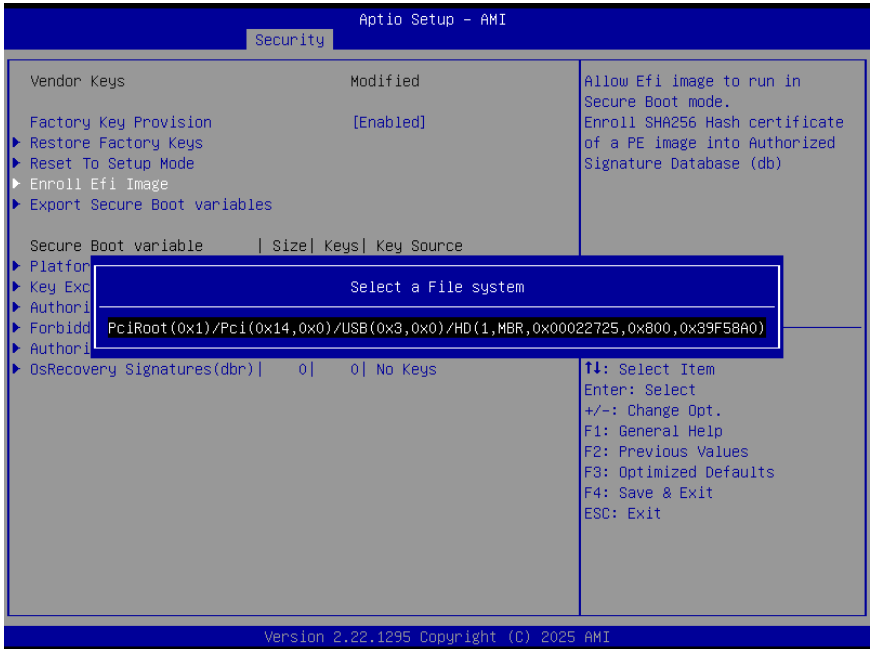

Options Summary

Enroll EFI Image

This item allows the image to run in Secure Boot mode.

Enroll SHA256 Hash certificate of a PE image into Authorized Signature Database (db).

Export Secure Boot Variables

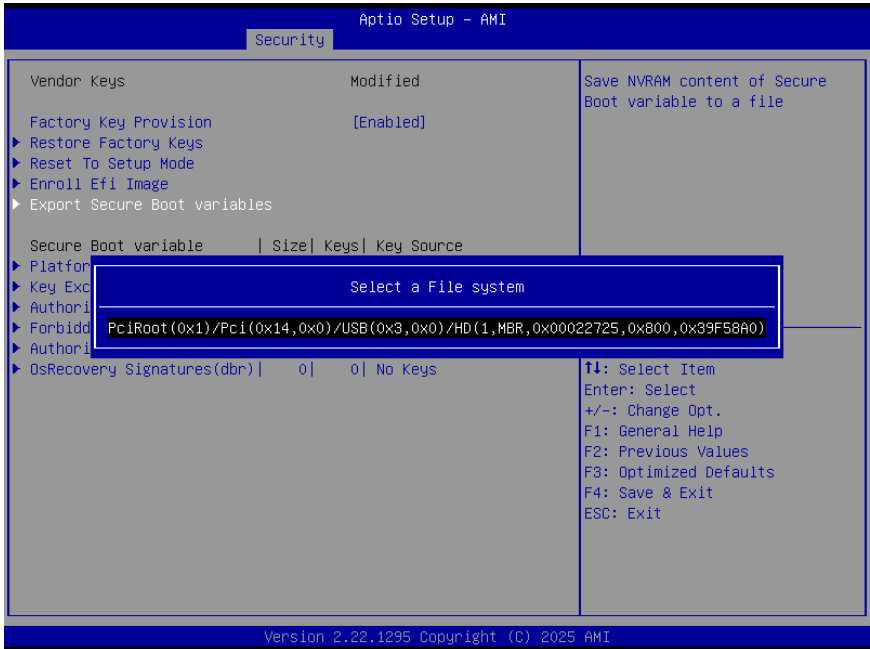

Options Summary

Export Secure Boot Variables

Save NVRAM content of Secure Boot variable to a file.

3.6.2.1 Platform Key (PK)

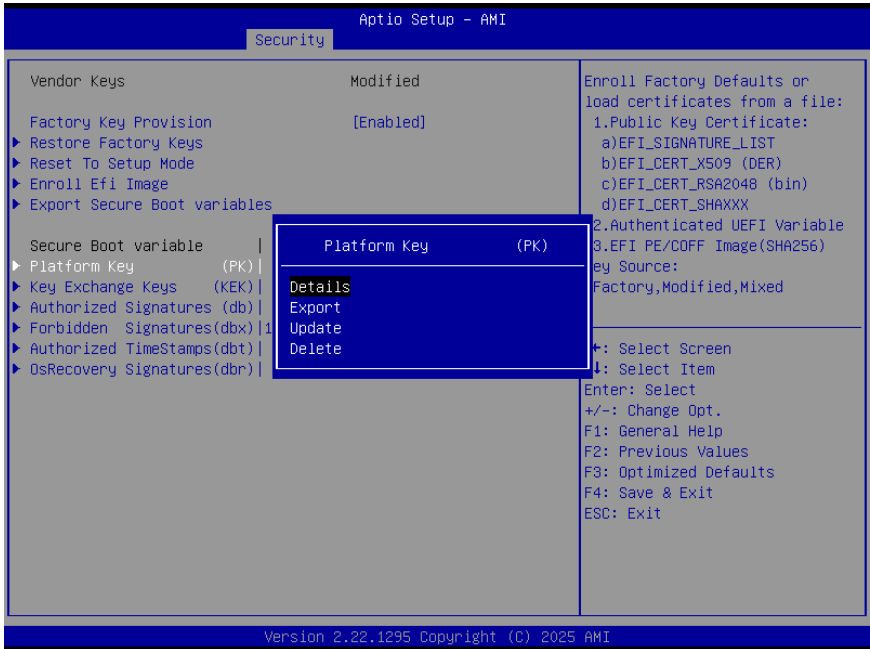

Options Summary	
Platform Key (PK)	Details
	Export
	Update
	Delete
<p>Use this item to enroll Factory Defaults or load certificates from a file:</p> <ol style="list-style-type: none"> Public Key Certificate: <ol style="list-style-type: none"> EFI_SIGNATURE_LIST EFI_CERT_X509 (DER) EFI_CERT_RSA2048 (bin) EFI_CERT_SHAXXX Authenticated UEFI Variable EFI PE/COFF Image (SHA256) <p>Key Source: Factory, Modified, Mixed.</p>	

3.6.2.2 Key Exchange Keys

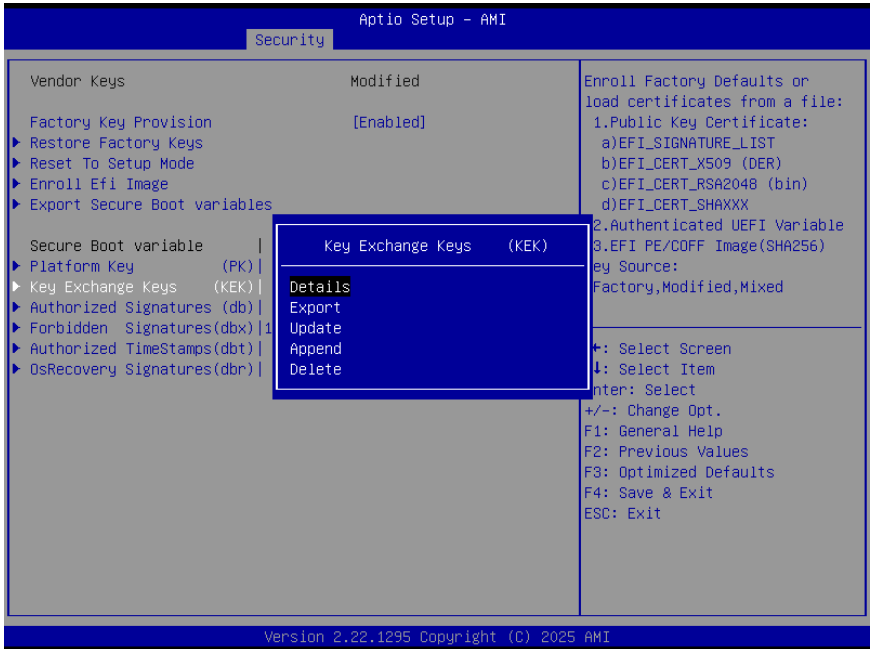

Options Summary	
Platform Key (PK)	Details
	Export
	Update
	Append
	Delete
Enroll Factory Defaults or load certificates from a file: 1. Public Key Certificate: a) EFI_SIGNATURE_LIST b) EFI_CERT_X509 (DER) c) EFI_CERT_RSA2048 (bin) d) EFI_CERT_SHAXXX 2. Authenticated UEFI Variable 3. EFI PE/COFF Image (SHA256) Key Source: Factory, Modified, Mixed	

3.6.2.3 Authorized Signatures

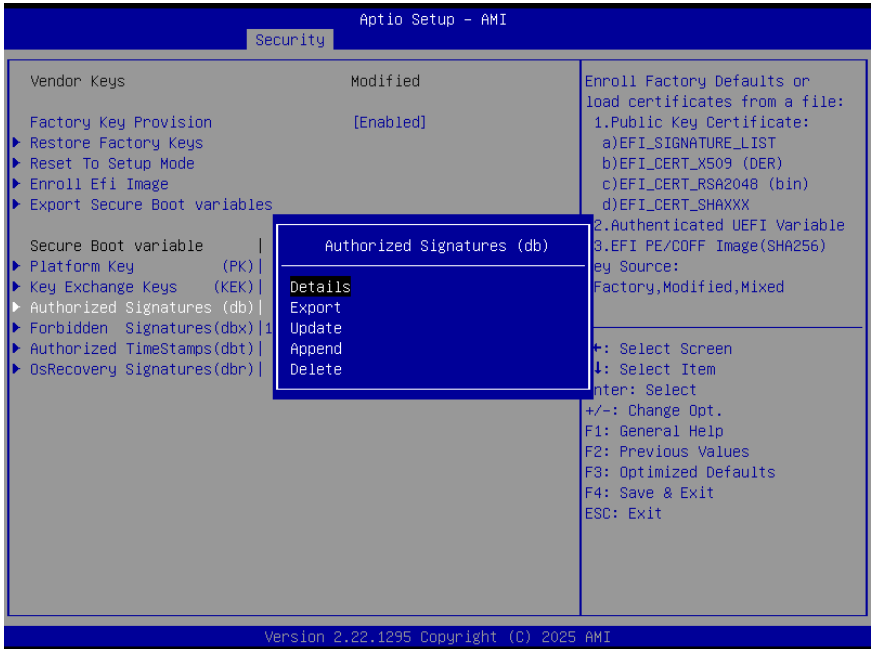

Options Summary	
Authorized Signatures (db)	Details
	Export
	Update
	Append
	Delete
<p>Enroll Factory Defaults or load certificates from a file:</p> <ol style="list-style-type: none"> Public Key Certificate: <ol style="list-style-type: none"> EFI_SIGNATURE_LIST EFI_CERT_X509 (DER) EFI_CERT_RSA2048 (bin) EFI_CERT_SHAXXX Authenticated UEFI Variable EFI PE/COFF Image (SHA256) <p>Key Source: Factory, Modified, Mixed</p>	

3.6.2.4 Forbidden Signatures

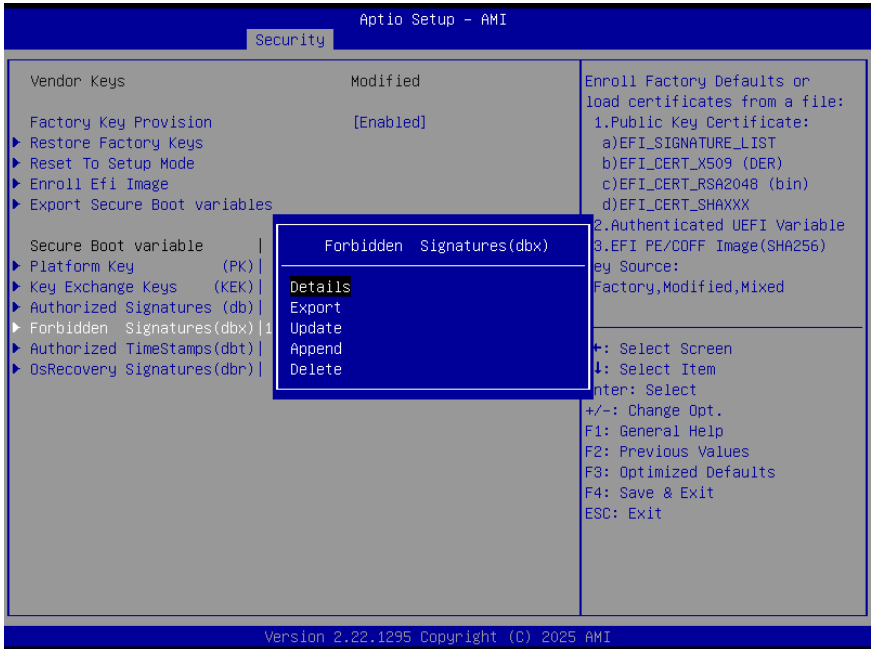

Options Summary	
Forbidden Signatures (dbx)	Details
	Export
	Update
	Append
	Delete
Enroll Factory Defaults or load certificates from a file: 1. Public Key Certificate: a) EFI_SIGNATURE_LIST b) EFI_CERT_X509 (DER) c) EFI_CERT_RSA2048 (bin) d) EFI_CERT_SHAXXX 2. Authenticated UEFI Variable 3. EFI PE/COFF Image (SHA256) Key Source: Factory, Modified, Mixed	

3.6.2.5 Authorized TimeStamps

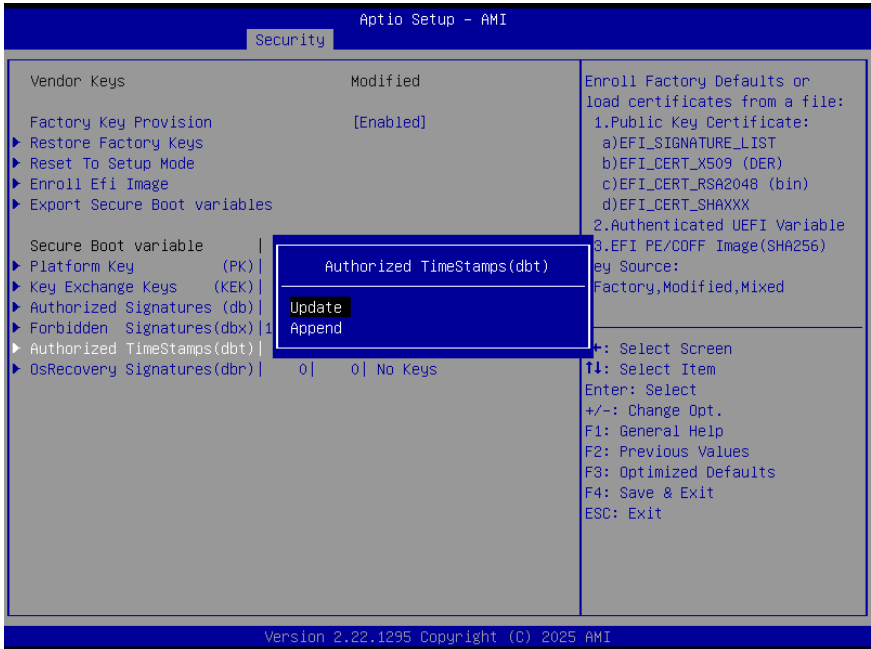

Options Summary	
Authorized TimeStamps (dbt)	Update
	Append
Enroll Factory Defaults or load certificates from a file: 1. Public Key Certificate: a) EFI_SIGNATURE_LIST b) EFI_CERT_X509 (DER) c) EFI_CERT_RSA2048 (bin) d) EFI_CERT_SHAXXX 2. Authenticated UEFI Variable 3. EFI PE/COFF Image (SHA256) Key Source: Factory, Modified, Mixed	

3.6.2.6 OsRecovery Signatures

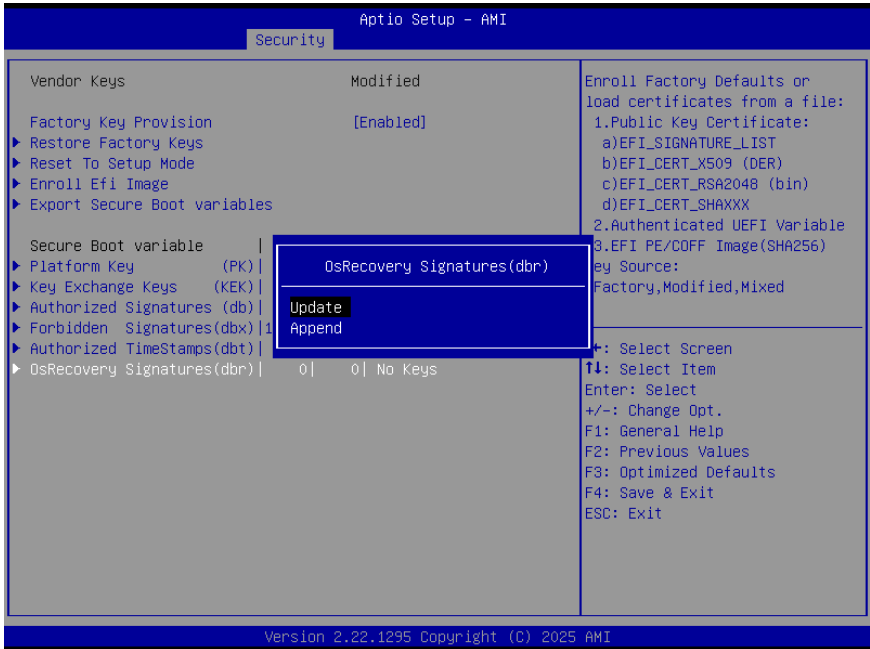

Options Summary	
OsRecovery Signatures (dbr)	Update
	Append
Enroll Factory Defaults or load certificates from a file: 1. Public Key Certificate: a) EFI_SIGNATURE_LIST b) EFI_CERT_X509 (DER) c) EFI_CERT_RSA2048 (bin) d) EFI_CERT_SHAXXX 2. Authenticated UEFI Variable 3. EFI PE/COFF Image (SHA256) Key Source: Factory, Modified, Mixed	

3.7 Setup Submenu: Boot

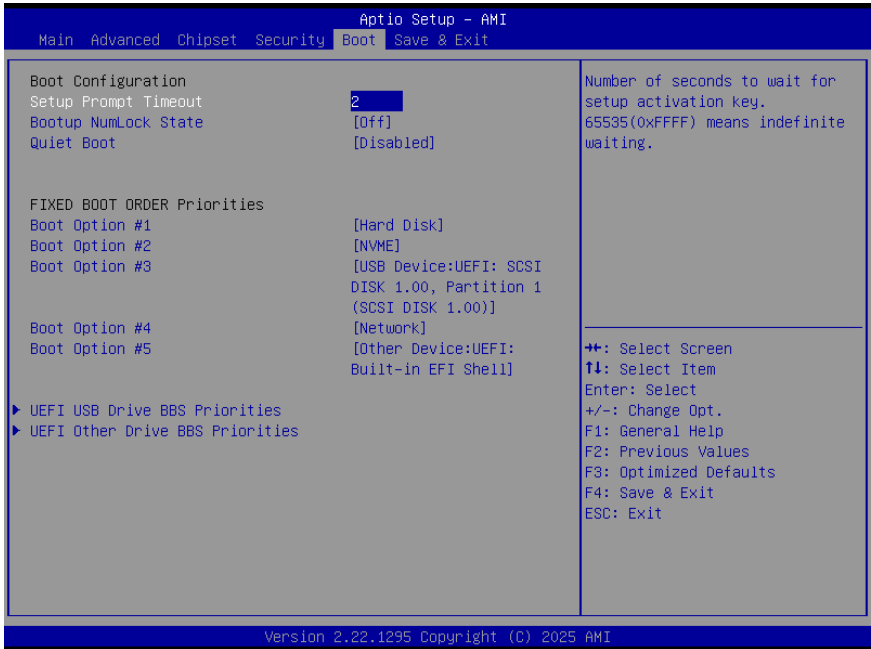

Options Summary	
Setup Prompt Timeout	2
Use this item to set number of seconds to wait for setup activation key. 65535 (0xFFFF) means indefinite waiting.	
Bootup NumLock State	On Off
Use this item to select keyboard NumLock state.	
Quiet Boot	Disabled Enabled
Enable or Disable Quiet Boot option.	
FIXED BOOT ORDER Priorities	
Sets the system boot order.	

3.7.1 BBS Priorities

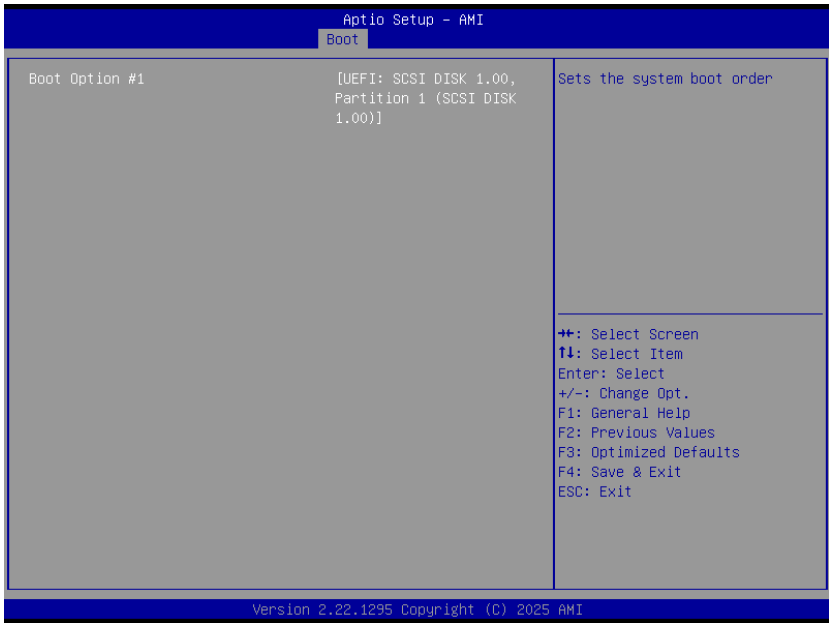

3.8 Setup Submenu: Save & Exit

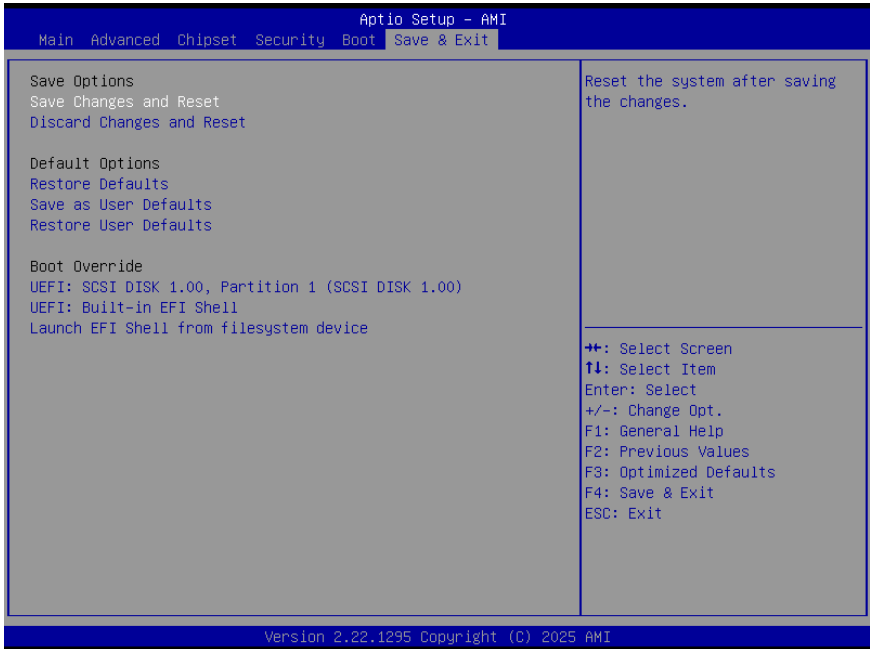

Once you are finished making your selections, choose this option from the **Save & Exit** menu to ensure the values you selected are saved. When you select this option, a confirmation window appears. Select **Yes** to save changes and reset.

Discard Changes and Exit

This option allows you to exit the Setup program without saving your changes. When you select this option or if you press <Esc>, a confirmation window appears. Select **Yes** to discard changes and exit.

Restore Defaults

Save or restore User Defaults to all setup options.

Appendix

Notices

FCC Statement

Warning!



This device complies with Part 15 FCC Rules. Operation is subject to the following two conditions: (1) this device may not cause harmful interference, and (2) this device must accept any interference received including interference that may cause undesired operation.

Caution:

There is a danger of explosion if the battery is incorrectly replaced. Replace only with the same or equivalent type recommended by the manufacturer. Dispose of used batteries according to the manufacturer's instructions and your local government's recycling or disposal directives.

Attention:

Il y a un risque d'explosion si la batterie est remplacée de façon incorrecte. Ne la remplacer qu'avec le même modèle ou équivalent recommandé par le constructeur. Recycler les batteries usées en accord avec les instructions du fabricant et les directives gouvernementales de recyclage.

China RoHS Requirements (CN)

产品中有毒有害物质或元素名称及含量

AAEON 主板/子板/背板

QO4-381 Rev.A2

部件名称	有毒有害物质或元素					
	铅 (Pb)	汞 (Hg)	镉 (Cd)	六价铬 (Cr(VI))	多溴联苯 (PBB)	多溴二苯醚 (PBDE)
印刷电路板 及其电子组件	×	○	○	○	○	○
外部信号 连接器及线材	×	○	○	○	○	○
<p>本表格依据 SJ/T 11364 的规定编制。</p> <p>○：表示该有毒有害物质在该部件所有均质材料中的含量均在GB/T 26572标准规定的限量要求以下。</p> <p>×：表示该有害物质的某一均质材料超出了GB/T 26572的限量要求，然而该部件仍符合欧盟指令2011/65/EU 的规范。</p> <p>环保使用期限(EFUP (Environmental Friendly Use Period))：10年</p> <p>备注：此产品所标示之环保使用期限，系指在一般正常使用状况下。</p>						

China RoHS Requirements (EN)

Name and content of hazardous substances in product

AAEON Main Board/Daughter Board/Backplane

QO4-381 Rev.A2

Part Name	Hazardous Substances					
	铅 (Pb)	汞 (Hg)	镉 (Cd)	六价铬 (Cr(VI))	多溴联苯 (PBB)	多溴二苯 醚(PBDE)
PCB Assemblies	×	○	○	○	○	○
Connector and Cable	×	○	○	○	○	○

The table is prepared in accordance with the provisions of SJ/T 11364.

○: Indicates that said hazardous substance contained in all of the homogenous materials for this product is below the limit requirement of GB/T 26572.

×: Indicates that said hazardous substance contained in at least one of the homogenous materials used for this part is above the limit requirement of GB/T 26572. But this product still be compliance with 2011/65/EU Directive (allowed with 2011/65/EU Annex III of RoHS exemption with number 6(c),7(a),7(c)-1).

EFUP (Environment Friendly Use Period) value: 10 years

Notes: This product defined period of use is under normal condition.