



# GENE-TWL5

---

3.5" Subcompact Board

User's Manual 1<sup>st</sup> Ed

## Copyright Notice

---

This document is copyrighted, 2025. All rights are reserved. The original manufacturer reserves the right to make improvements to the products described in this manual at any time without notice.

No part of this manual may be reproduced, copied, translated, or transmitted in any form or by any means without the prior written permission of the original manufacturer. Information provided in this manual is intended to be accurate and reliable. However, the original manufacturer assumes no responsibility for its use, or for any infringements upon the rights of third parties that may result from its use.

The material in this document is for product information only and is subject to change without notice. While reasonable efforts have been made in the preparation of this document to assure its accuracy, AAEMON assumes no liabilities resulting from errors or omissions in this document, or from the use of the information contained herein.

AAEMON reserves the right to make changes in the product design without notice to its users.

## Acknowledgements

---

All other products' name or trademarks are properties of their respective owners.

- Microsoft Windows is a registered trademark of Microsoft Corp.
- Intel® is a registered trademark of Intel Corporation
- Intel Core™ is a trademark of Intel Corporation
- Realtek is a trademark of Realtek Semiconductor Corporation.
- Ubuntu is a trademark of Canonical.
- Linux® is the registered trademark of Linus Torvalds in the U.S. and other countries

All other product names or trademarks are properties of their respective owners.

## Packing List

---

Before setting up your product, please make sure the following items have been shipped:

| Item      | Quantity |
|-----------|----------|
| GENE-TWL5 | 1        |
| Heatsink  | 1        |

If any of these items are missing or damaged, please contact your distributor or sales representative immediately.

## About this Document

---

This User's Manual contains all the essential information, such as detailed descriptions and explanations on the product's hardware and software features (if any), its specifications, dimensions, jumper/connector settings/definitions, and driver installation instructions (if any), to facilitate users in setting up their product.

Users may refer to the product page at [AAEON.com](http://AAEON.com) for the latest version of this document.

## Safety Precautions

---

Please read the following safety instructions carefully. It is advised that you keep this manual for future references

1. All cautions and warnings on the device should be noted.
2. Make sure the power source matches the power rating of the device.
3. Position the power cord so that people cannot step on it. Do not place anything over the power cord.
4. Always completely disconnect the power before working on the system's hardware.
5. No connections should be made when the system is powered as a sudden rush of power may damage sensitive electronic components.
6. If the device is not to be used for a long time, disconnect it from the power supply to avoid damage by transient over-voltage.
7. Always disconnect this device from any AC supply before cleaning.
8. While cleaning, use a damp cloth instead of liquid or spray detergents.
9. Make sure the device is installed near a power outlet and is easily accessible.
10. Keep this device away from humidity.
11. Place the device on a solid surface during installation to prevent falls
12. Do not cover the openings on the device to ensure optimal heat dissipation.
13. Watch out for high temperatures when the system is running.
14. Do not touch the heat sink or heat spreader when the system is running
15. Never pour any liquid into the openings. This could cause fire or electric shock.
16. As most electronic components are sensitive to static electrical charge, be sure to ground yourself to prevent static charge when installing the internal components. Use a grounding wrist strap and contain all electronic components in any static-shielded containers.

17. If any of the following situations arises, please the contact our service personnel:
  - i. Damaged power cord or plug
  - ii. Liquid intrusion to the device
  - iii. Exposure to moisture
  - iv. Device is not working as expected or in a manner as described in this manual
  - v. The device is dropped or damaged
  - vi. Any obvious signs of damage displayed on the device
18. **DO NOT LEAVE THIS DEVICE IN AN UNCONTROLLED ENVIRONMENT WITH TEMPERATURES BEYOND THE DEVICE'S PERMITTED STORAGE TEMPERATURES (SEE CHAPTER 1) TO PREVENT DAMAGE.**

## FCC Statement

---

### **Warning!**



This device complies with Part 15 FCC Rules. Operation is subject to the following two conditions: (1) this device may not cause harmful interference, and (2) this device must accept any interference received including interference that may cause undesired operation.

### **Caution:**

*There is a danger of explosion if the battery is incorrectly replaced. Replace only with the same or equivalent type recommended by the manufacturer. Dispose of used batteries according to the manufacturer's instructions and your local government's recycling or disposal directives.*

### **Attention:**

*Il y a un risque d'explosion si la batterie est remplacée de façon incorrecte. Ne la remplacer qu'avec le même modèle ou équivalent recommandé par le constructeur. Recycler les batteries usées en accord avec les instructions du fabricant et les directives gouvernementales de recyclage.*

## 产品中有毒有害物质或元素名称及含量

AAEON 主板/子板/背板

QO4-381 Rev.A2

| 部件名称            | 有毒有害物质或元素 |           |           |                 |               |                 |
|-----------------|-----------|-----------|-----------|-----------------|---------------|-----------------|
|                 | 铅<br>(Pb) | 汞<br>(Hg) | 镉<br>(Cd) | 六价铬<br>(Cr(VI)) | 多溴联苯<br>(PBB) | 多溴二苯醚<br>(PBDE) |
| 印刷电路板<br>及其电子组件 | ×         | ○         | ○         | ○               | ○             | ○               |
| 外部信号<br>连接器及线材  | ×         | ○         | ○         | ○               | ○             | ○               |

本表格依据 SJ/T 11364 的规定编制。

○：表示该有毒有害物质在该部件所有均质材料中的含量均在GB/T 26572标准规定的限量要求以下。

×：表示该有害物质的某一均质材料超出了GB/T 26572的限量要求，然而该部件仍符合欧盟指令2011/65/EU 的规范。

环保使用期限(EFUP (Environmental Friendly Use Period))：10年

备注：此产品所标示之环保使用期限，系指在一般正常使用状况下。

## China RoHS Requirement (EN)

Name and content of hazardous substances in product

AAEON Main Board/Daughter Board/Backplane

QO4-381 Rev.A2

| Part Name           | Hazardous Substances |           |           |                 |               |                 |
|---------------------|----------------------|-----------|-----------|-----------------|---------------|-----------------|
|                     | 铅<br>(Pb)            | 汞<br>(Hg) | 镉<br>(Cd) | 六价铬<br>(Cr(VI)) | 多溴联苯<br>(PBB) | 多溴二苯醚<br>(PBDE) |
| PCB Assemblies      | ×                    | ○         | ○         | ○               | ○             | ○               |
| Connector and Cable | ×                    | ○         | ○         | ○               | ○             | ○               |

The table is prepared in accordance with the provisions of SJ/T 11364.

○: Indicates that said hazardous substance contained in all of the homogenous materials for this product is below the limit requirement of GB/T 26572.

×: Indicates that said hazardous substance contained in at least one of the homogenous materials used for this part is above the limit requirement of GB/T 26572. But this product still be compliance with 2011/65/EU Directive (allowed with 2011/65/EU Annex III of RoHS exemption with number 6(c),7(a),7(c)-1).

EFUP (Environment Friendly Use Period) value: 10 years

Notes: This product defined period of use is under normal condition.

## Table of Contents

---

|   |          |
|---|----------|
| <b>Chapter 1 - Product Specifications</b> .....                     | <b>1</b> |
| 1.1 Specifications .....  | 2        |
| 1.2 Block Diagram .....   | 6        |
| <b>Chapter 2 – Hardware Information</b> .....                       | <b>7</b> |
| 2.1 Dimensions .....  | 8        |
| 2.2 Jumpers and Connectors.....                                     | 9        |
| 2.3 List of Jumpers .....   | 11       |
| 2.3.1 Auto Power Button AT/ATX Selection (JP1) .....                | 12       |
| 2.3.2 COM 1 RI Jumper (JP2) .....                                   | 13       |
| 2.3.3 COM 2 RI Jumper (JP3).....                                    | 14       |
| 2.3.4 LVDS Power Jumper (JP4) .....                                 | 15       |
| 2.3.5 Clear CMOS Jumper (JP5).....                                  | 16       |
| 2.3.6 Touch Jumper (JP6).....                                       | 17       |
| 2.4 List of Connectors.....   | 18       |
| 2.4.1 USB 2.0 Connector (5Pin*1 Board to Wire) (CN1) .....          | 20       |
| 2.4.2 4-Pin Fan Connector (CN2) .....                               | 21       |
| 2.4.3 +5V Output for SATA HDD (CN4) .....                           | 22       |
| 2.4.4 Port 80 Debug Port (10Pin*1 Board to Wire) (CN5).....         | 22       |
| 2.4.5 SPI Flash Programming Port (7Pin*1 Board to Wire) (CN6) ..... | 23       |
| 2.4.6 Front Panel (10Pin*1 Board to Wire) (CN7) .....               | 24       |
| 2.4.7 SMBus/I2C Connector (With SMB_ALERT/INT_SERIRQ) (CN8).....    | 25       |
| 2.4.8 SATA Port (CN9) .....   | 26       |
| 2.4.9 Audio In/Out (6Pin*2 Board to Wire) (CN10).....               | 27       |
| 2.4.10 USB 2.0 Connector (5Pin*1 Board to Wire) (CN11).....         | 28       |
| 2.4.11 ATX 4-Pin DC Input Socket (CN12).....                        | 29       |
| 2.4.12 Terminal Block DC Input Connector (CN13) .....               | 30       |

|   |   |           |
|---|---|-----------|
| 2.4.13                                  | External +5VSB Input (CN14).....                                  | 30        |
| 2.4.14                                  | GPIO Port (5Pin*2 Board to Wire Type 1) (CN15).....               | 31        |
| 2.4.15                                  | COM Port 3 (9Pin*1 Board to Wire) (CN16).....                     | 32        |
| 2.4.16                                  | COM Port 4 (9Pin*1 Board to Wire) (CN17).....                     | 33        |
| 2.4.17                                  | COM Port 1 (9Pin*1 Board to Wire) (CN18).....                     | 34        |
| 2.4.18                                  | COM Port 2 (9Pin*1 Board to Wire) (CN19).....                     | 35        |
| 2.4.19                                  | LVDS/eDP Connector (CN21) .....                                   | 37        |
| 2.4.20                                  | LVDS Inverter/Backlight Connector (6Pin*1 Board to Wire) (CN22).. | 40        |
| 2.4.21                                  | RTC Battery Connector (CN23).....                                 | 41        |
| 2.4.22                                  | USB 2.0 Connector (5Pin*1 Board to Wire) (CN24).....              | 41        |
| 2.4.23                                  | USB 2.0 Connector (5Pin*1 Board to Wire) (CN25).....              | 42        |
| 2.4.24                                  | HDMI Port (CN26).....   | 43        |
| 2.4.25                                  | Dual RJ-45 LAN Port (CN28).....                                   | 44        |
| 2.4.26                                  | USB 3.2/USB 2.0 Port 1/Port 2 (CN29).....                         | 45        |
| 2.4.27                                  | IMVP9 FW Reflash (CN30) .....                                     | 46        |
| 2.4.28                                  | Touch Screen Lines (CN31).....                                    | 46        |
| 2.4.29                                  | VGA Port (CN32).....  | 47        |
| 2.4.30                                  | DDR5 SODIMM Slot (CN33).....                                      | 48        |
| 2.4.31                                  | Mini Card Slot (Full-size mSATA/mPCIe) (CN34).....                | 49        |
| 2.4.32                                  | M.2 2230 E-Key Slot (CN35).....                                   | 51        |
| 2.4.33                                  | Nano SIM Card Slot (CN36).....                                    | 53        |
| 2.4.34                                  | M.2 3052 B-Key Slot (CN37).....                                   | 54        |
| 2.5                                     | Thermal Solutions.....  | 57        |
| 2.5.1                                   | Heatsink .....  | 57        |
| <b>Chapter 3 - AMI BIOS Setup .....</b> |   | <b>59</b> |
| 3.1                                     | System Test and Initialization .....                              | 60        |
| 3.2                                     | AMI BIOS Setup .....  | 61        |
| 3.3                                     | Setup Submenu: Main.....  | 62        |

|         |  |    |
|---------|--|----|
| 3.4     | Setup Submenu: Advanced.....             | 63 |
| 3.4.1   | CPU Configuration.....                   | 64 |
| 3.4.2   | PCH-FW Configuration.....                | 65 |
| 3.4.3   | Firmware Update Configuration .....      | 66 |
| 3.4.4   | PTT Configuration.....                   | 67 |
| 3.4.5   | Trusted Computing.....                   | 68 |
| 3.4.6   | SATA Configuration.....                  | 70 |
| 3.4.7   | Hardware Monitor .....                   | 71 |
| 3.4.7.1 | Smart Fan Mode Configuration .....       | 72 |
| 3.4.8   | SIO Configuration .....                  | 73 |
| 3.4.8.1 | Serial Port 1 Configuration .....        | 74 |
| 3.4.8.2 | Serial Port 2 Configuration .....        | 75 |
| 3.4.8.3 | Serial Port 3 Configuration .....        | 76 |
| 3.4.8.4 | Serial Port 4 Configuration .....        | 77 |
| 3.4.9   | Serial Port Console Redirection .....    | 78 |
| 3.4.10  | Legacy Console Redirection Settings..... | 79 |
| 3.4.11  | AAEON BIOS Robot .....                   | 80 |
| 3.4.12  | Power Management.....                    | 82 |
| 3.4.13  | GPIO Port Configuration .....            | 83 |
| 3.5     | Setup Submenu: Chipset .....             | 84 |
| 3.5.1   | System Agent (SA) Configuration.....     | 85 |
| 3.5.2   | Memory Configuration.....                | 86 |
| 3.5.3   | LVDS Panel Configuration .....           | 87 |
| 3.5.4   | PCH-IO Configuration .....               | 88 |
| 3.6     | Setup Submenu: Security.....             | 90 |
| 3.6.1   | Secure Boot.....                         | 91 |
| 3.6.2   | Key Management.....                      | 92 |
| 3.7     | Setup Submenu: Boot .....                | 94 |

|                   |  |            |
|-------------------|--|------------|
| 3.7.1             | BBS Priorities .....                       | 95         |
| 3.8               | Setup Submenu: Save & Exit.....            | 96         |
| <b>Chapter 4</b>  | <b>– Driver Installation .....</b>         | <b>97</b>  |
| 4.1               | Driver Download/Installation .....         | 98         |
| <b>Appendix A</b> | <b>- I/O Information.....</b>              | <b>101</b> |
| A.1               | I/O Address Map .....                      | 102        |
| A.2               | Memory Address Map .....                   | 105        |
| A.3               | IRQ Mapping Chart.....                     | 107        |
| <b>Appendix B</b> | <b>– Mating Connectors and Cables.....</b> | <b>116</b> |
| B.1               | Mating Connectors and Cables.....          | 117        |

# Chapter 1

---

Product Specifications

## 1.1 Specifications

---

### System

|                |   |
|----------------|---|
| Form Factor    | 3.5" SubCompact Board   |
| CPU            | Intel® Processor N150<br>(4C/4T, up to 3.6 GHz, 6W)<br>Intel® Core™ 3 Processor N355<br>(8C/8T, up to 3.90GHz, 15W) |
| Chipset        | Integrated with Intel® SoC  |
| Memory Type    | DDR5 4800, Single-Channel SODIMM x 1, Max 16GB,<br>Non-ECC  |
| BIOS           | UEFI  |
| Wake on LAN    | Yes   |
| Watchdog Timer | 255 Levels  |
| Security       | TPM 2.0   |
| RTC Battery    | Lithium Battery 3V/240mAH   |
| Dimension      | 5.75" x 4" (146mm x 101.7mm)  |
| Weight         | 1.1 lb. (0.5Kg)   |
| OS Support     | Windows® 10 (64-bit)<br>Windows® 11 (64-bit)<br>Ubuntu 24.04.2/kernel 6.11.0-17-generic                             |

### Power

|                   |  |
|-------------------|--|
| Power Requirement | +9V – 36V (Optional: +12V), supports ERP                               |
| Power Supply Type | AT/ATX, supports 3-pin ATX   |
| Connector         | Phoenix 2-pin Connector (Colay 4 pin Connector)                        |
| Power Consumption | Intel® Core™ 3 Processor N355, DDR5 16GB x 1,<br>3.43A @+12V (Typical) |

## Power

|                                  |  |
|----------------------------------|--|
| <b>Power Consumption (Cont.)</b> | Intel® Core™ 3 Processor N355, DDR5 16GB x 1,<br>5.13A @+12V (Max) |
|----------------------------------|--|

## Display

|                          |   |
|--------------------------|---|
| <b>Controller</b>        | Intel® UHD Graphics   |
| <b>LVDS/eDP</b>          | LVDS x 1, Dual-Channel 18/24-bit, up to 1920 x 1080<br>eDP HBR3 x 1, up to 1920 x 1200 (Optional) |
| <b>Display Interface</b> | HDMI 1.4 x 1, up to 3840 x 2160 @30Hz<br>VGA x 1, up to 1920 x 1080                               |
| <b>Multiple Display</b>  | Up to 3 Simultaneous Displays   |

## Audio

|                        |   |
|------------------------|---|
| <b>Codec</b>           | Realtek ALC897  |
| <b>Audio Interface</b> | Line-In/Line-Out/Mic, (audio function not available on<br>WiTAS SKUs) |
| <b>Speaker</b>         | —   |

## External I/O

|                    |   |
|--------------------|---|
| <b>Ethernet</b>    | Intel® Ethernet Controller I226, 2.5GbE x 2 |
| <b>USB</b>         | USB 3.2 Gen 2 x 2 Ports                     |
| <b>Serial Port</b> | —   |
| <b>Video</b>       | HDMI 1.4 x 1<br>VGA x 1                     |

## Internal I/O

|                    |   |
|--------------------|---|
| <b>USB</b>         | USB 2.0 x 4                                       |
| <b>Serial Port</b> | COM 1, COM 2 (RS-232/422/485, supports 5V/12V/RI) |

## Internal I/O

|             |  |
|-------------|--|
|             | COM 3, COM 4 (RS-232)  |
| Video       | LVDS x 1<br>eDP x 1<br>Inverter x 1 (12V/2A)                           |
| SATA        | SATA 6Gb/s x 1<br>+5V SATA Power Connector x 1                         |
| Audio       | Audio Header x 1 (Optional, Audio function not available on WiTAS SKU) |
| DIO/GPIO    | 8-bit GPIO   |
| SMBus/I2C   | SMBus/I2C x 1 (Default: SMBus)   |
| Touch       | 4/5/8-wire Touch Controller x 1 (Optional)                             |
| Fan         | 4-pin Smart Fan x 1  |
| Sim         | Nano SIM x 1   |
| Front Panel | HDD LED, PWR LED, Power Button, Buzzer, Reset                          |
| Others      | —  |

## Expansion

|                 |  |
|-----------------|--|
| Mini PCIe/mSATA | Full-size mSATA/mPCIe x 1 (Default: mPCIe, select by BIOS)   |
| M.2             | M.2 3052 B-Key x 1 (PCIe 3.0 [x1] + USB 3.2 Gen 2/PCIe 3.0 [x2] + USB 2.0, default: PCIe [x1] + USB 3.2 Gen 2, selected by BIOS)<br>M.2 2230 E-Key x 1 (PCIe 3.0 [x1] + USB 2.0, support CNVi) |
| Others          | —  |

## Environmental

|                       |  |
|-----------------------|--|
| Operating Temperature | -4°F – 158°F (-20°C – 70°C)                |
| Storage Temperature   | -40°F – 185°F (-40°C – 85°C)               |
| Operating Humidity    | 0% – 90% relative humidity, non-condensing |
| MTBF (Hours)          | 1,284,701                                  |
| EMC                   | CE/FCC Class A                             |

## 1.2 Block Diagram

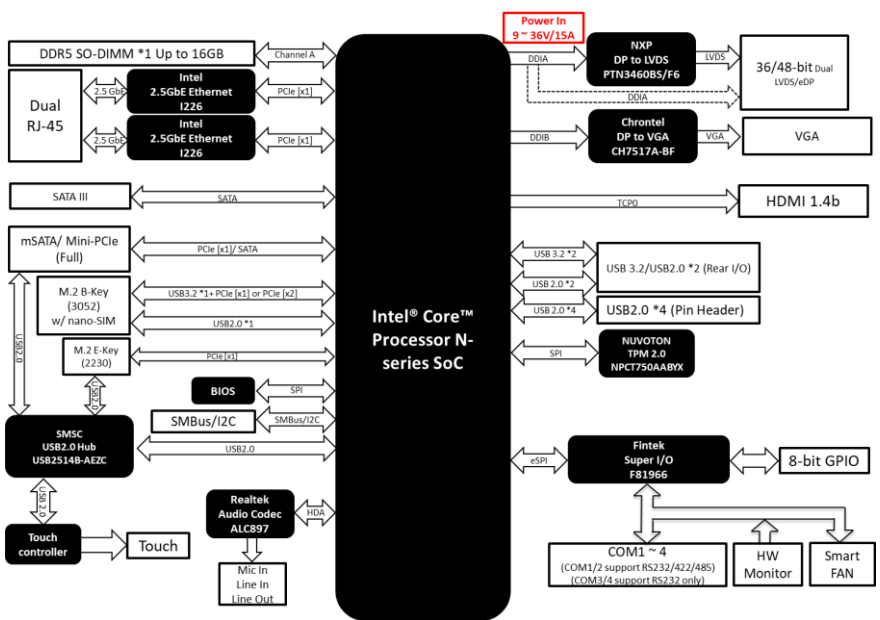

# Chapter 2

---

Hardware Information

## 2.1 Dimensions

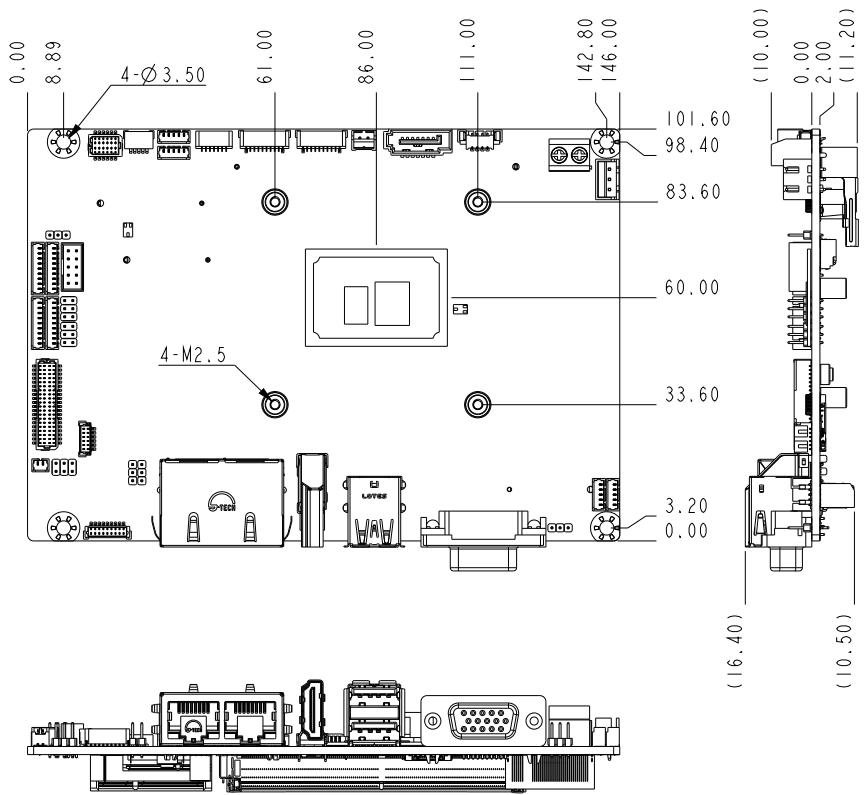



Bottom View

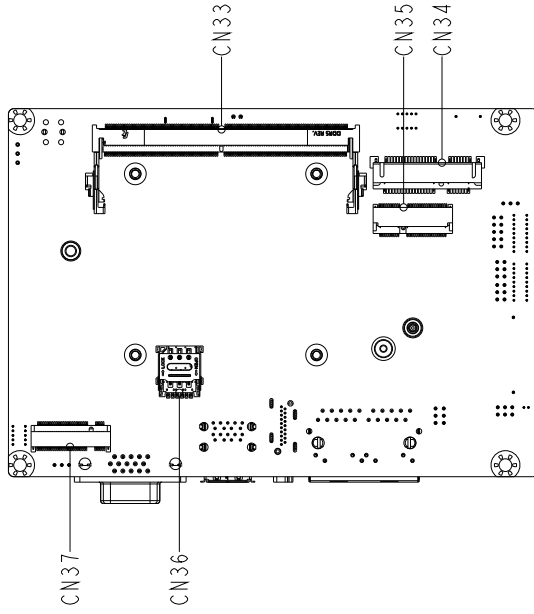

## 2.3 List of Jumpers

---

Please refer to the table below for all of the board's jumpers that you can configure for your application

| Label | Function                           |
|-------|------------------------------------|
| JP1   | Auto Power Button AT/ATX Selection |
| JP2   | COM 1 RI Jumper                    |
| JP3   | COM 2 RI Jumper                    |
| JP4   | LVDS Power Jumper                  |
| JP5   | Clear CMOS Jumper                  |
| JP6   | Touch Jumper                       |

### 2.3.1 Auto Power Button AT/ATX Selection (JP1)

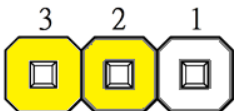
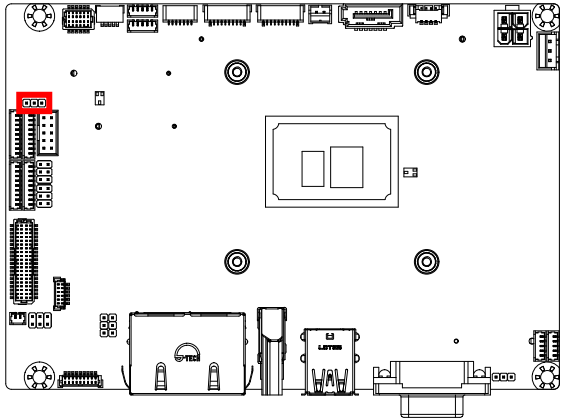

Enable Auto Power Button (Default)

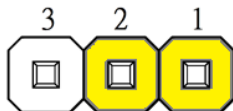

Disable Auto Power Button

### 2.3.2 COM 1 RI Jumper (JP2)

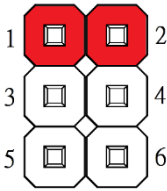
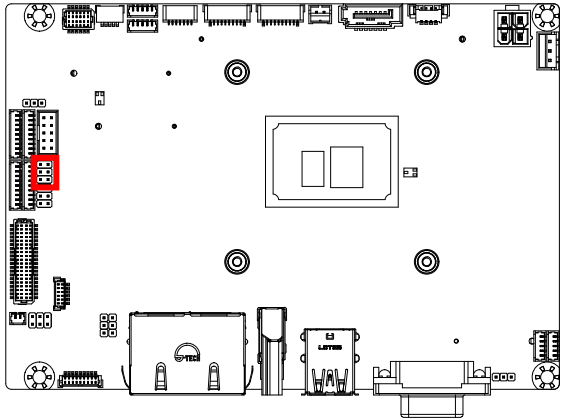

+12V

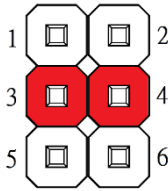

Ring (Default)

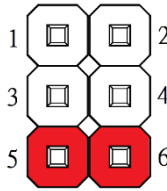

+5V

### 2.3.3 COM 2 RI Jumper (JP3)

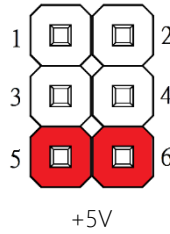
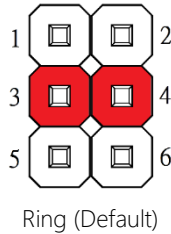
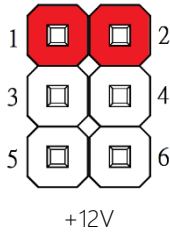
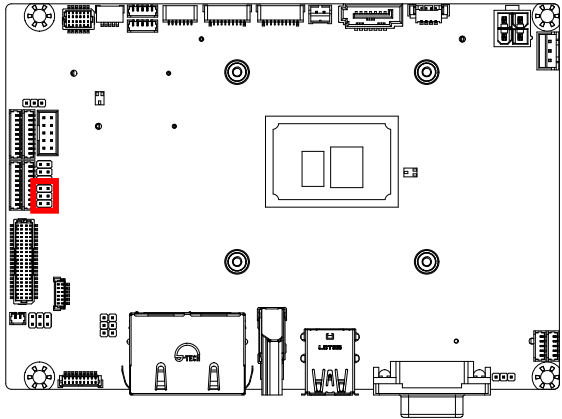

### 2.3.4 LVDS Power Jumper (JP4)

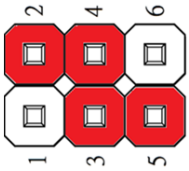
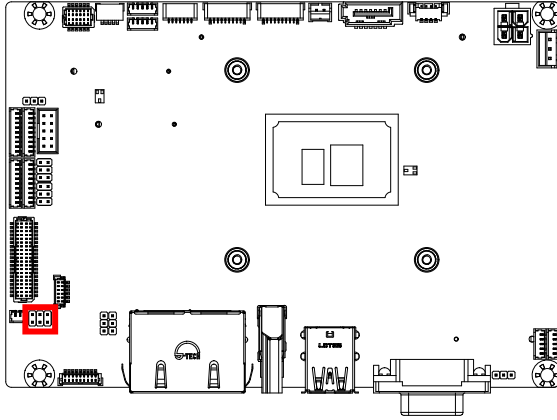

2-4 LVDS Power +3.3V(Default)

3-5 LVDS BKLT Power +5V(Default)

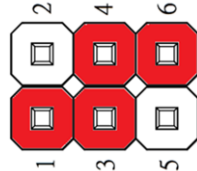

4-6 LVDS Power +5V

1-3 LVDS BKLT Power +12V

### 2.3.5 Clear CMOS Jumper (JP5)

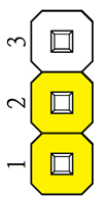
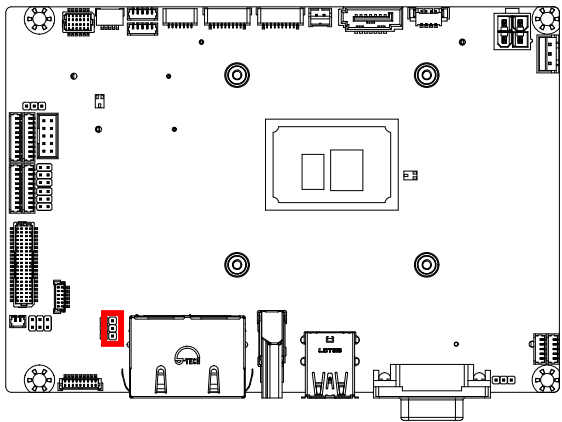

Normal (Default)

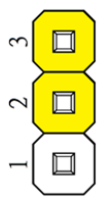

Clear CMOS

### 2.3.6 Touch Jumper (JP6)

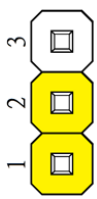
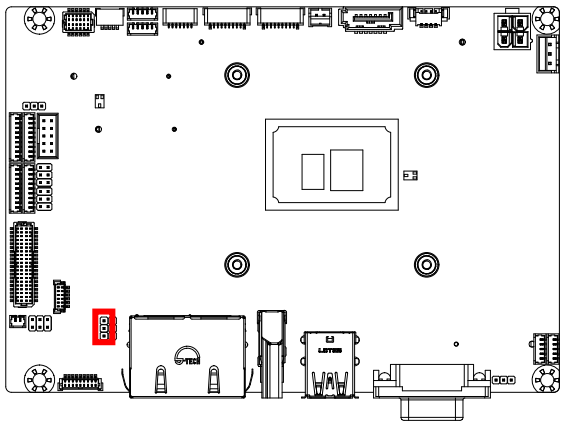

4,8 wire (Default)

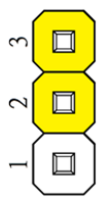

5 wire

## 2.4 List of Connectors

---

Please refer to the table below for all of the board's connectors that you can configure for your application

| Label | Function  |
|-------|---|
| CN1   | USB 2.0 Connector (5Pin*1 Board to Wire)                    |
| CN2   | 4-Pin Fan Connector   |
| CN4   | +5V Output for SATA HDD                                     |
| CN5   | Port 80 Debug Port (10Pin*1 Board to Wire)                  |
| CN6   | SPI Flash Programming Port (7Pin*1 Board to Wire)           |
| CN7   | Front Panel (10Pin*1 Board to Wire)                         |
| CN8   | SMBus/I2C Connector (With SMB_ALERT/INT_SERIRQ)             |
| CN9   | SATA Port   |
| CN10  | Audio In/Out (6Pin*2 Board to Wire)                         |
| CN11  | USB 2.0 Connector (5Pin*1 Board to Wire)                    |
| CN12  | ATX 4-Pin DC Input Socket [Reserved]                        |
| CN13  | Terminal Block DC Input Connector                           |
| CN14  | External +5VSB Input  |
| CN15  | GPIO Port (5Pin*2 Board to Wire Type 1)                     |
| CN16  | COM Port 3 (9Pin*1 Board to Wire)                           |
| CN17  | COM Port 4 (9Pin*1 Board to Wire)                           |
| CN18  | COM Port 1 (9Pin*1 Board to Wire)                           |
| CN19  | COM Port 2 (9Pin*1 Board to Wire)                           |
| CN21  | LVDS/eDP Connector  |
| CN22  | LVDS Inverter/Backlight Connector (6Pin*1 Board to Wire)    |
| CN23  | RTC Battery Connector                                       |
| CN24  | USB 2.0 Connector (5Pin*1 Board to Wire)                    |
| CN25  | USB 2.0 Connector (5Pin*1 Board to Wire)                    |
| CN26  | HDMI Port   |
| CN28  | Dual RJ-45 LAN Port (Left: Port 1-I226, Right: Port 2-I226) |
| CN29  | USB 3.2/USB 2.0 Port 1/Port 2                               |
| CN30  | IMVP9 FW Reflash  |
| CN31  | Touch Screen Lines  |
| CN32  | VGA Port  |
| CN33  | DDR5 SODIMM Slot  |
| CN34  | Mini Card Slot (Full-size mSATA/mPCIe)                      |

| Label | Function            |
|-------|---------------------|
| CN35  | M.2 2230 E-Key Slot |
| CN36  | Nano SIM Card Slot  |
| CN37  | M.2 3052 B-Key Slot |

## 2.4.1 USB 2.0 Connector (5Pin\*1 Board to Wire) (CN1)

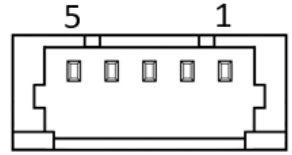
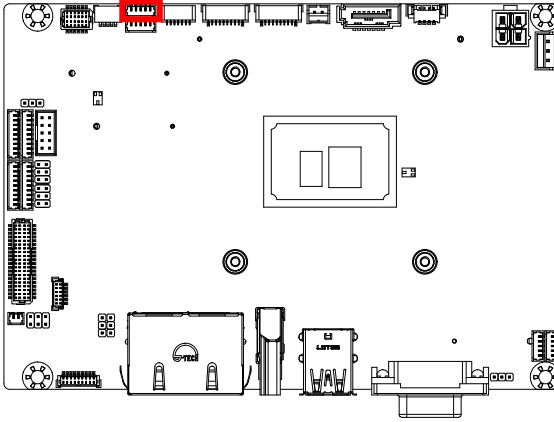

| Pin | Pin Name  | Signal Type | Signal Level |
|-----|-----------|-------------|--------------|
| 1   | +5VSB     | PWR         | +5V          |
| 2   | USB2_6_DN | DIFF        | -            |
| 3   | USB2_6_DP | DIFF        | -            |
| 4   | GND       | GND         | GND          |
| 5   | GND       | GND         | GND          |

**Note:** The driving current of +5VSB supports up to 0.5A/Port.

## 2.4.2 4-Pin Fan Connector (CN2)

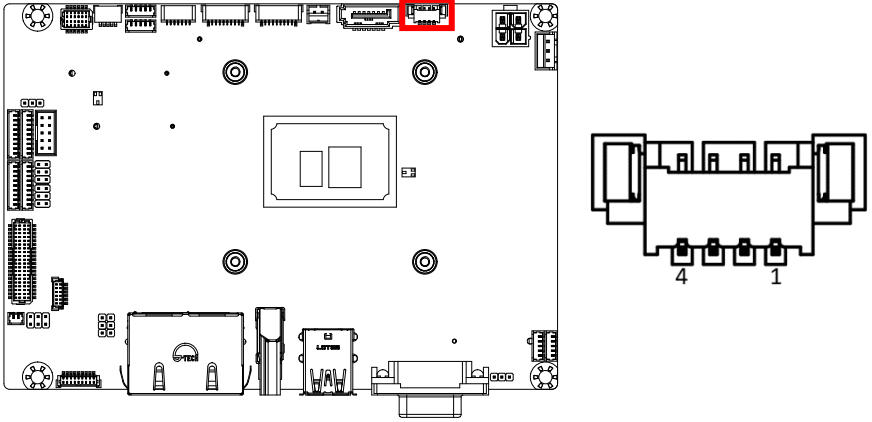

| Pin | Pin Name  | Signal Type | Signal Level |
|-----|-----------|-------------|--------------|
| 1   | GND       | GND         | GND          |
| 2   | FAN_POWER | PWR         | +12V         |
| 3   | FAN_TAC   | IN          | -            |
| 4   | FAN_CTL   | OUT         | -            |

**Note:** The driving current of FAN\_POWER supports up to 1A.

### 2.4.3 +5V Output for SATA HDD (CN4)

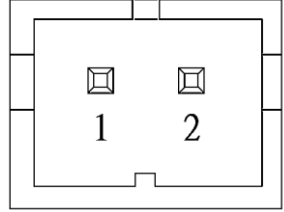
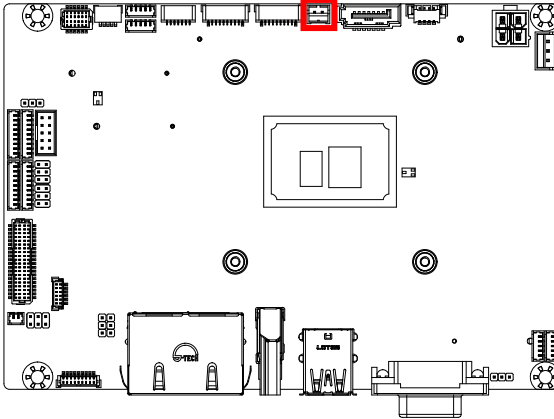

| Pin | Pin Name | Signal Type | Signal Level |
|-----|----------|-------------|--------------|
| 1   | +V5S     | PWR         | +5V          |
| 2   | GND      | GND         | GND          |

**Note:** The driving current of +V5S supports up to 1A.

### 2.4.4 Port 80 Debug Port (10Pin\*1 Board to Wire) (CN5)

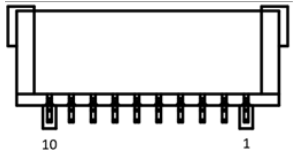
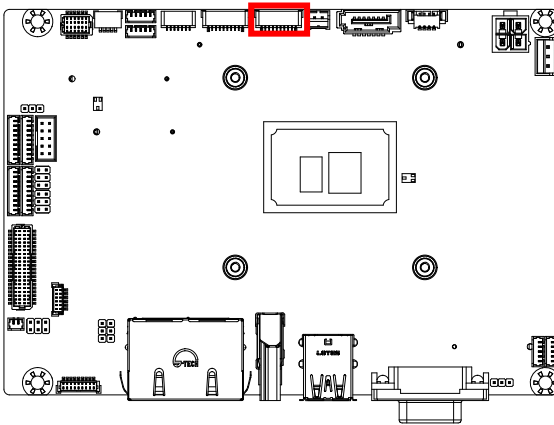

| Pin | Pin Name        | Signal Type | Signal Level |
|-----|-----------------|-------------|--------------|
| 1   | +V3P3A          | PWR         | +3.3V        |
| 2   | ESPI_CLK_EC_R   | OUT         | +1.8V        |
| 3   | GND             | GND         | GND          |
| 4   | ESPI_RST_EC_R_N | OUT         | +1.8V        |
| 5   | ESPI_CS_EC_R_N  | OUT         | -3.3V        |
| 6   | +V3P3S          | PWR         | +3.3V        |
| 7   | ESPI_IO3_EC_R   | IN/OUT      | +1.8V        |
| 8   | ESPI_IO2_EC_R   | IN/OUT      | +1.8V        |
| 9   | ESPI_IO1_EC_R   | IN/OUT      | +1.8V        |
| 10  | ESPI_IO0_EC_R   | IN/OUT      | +1.8V        |

## 2.4.5 SPI Flash Programming Port (7Pin\*1 Board to Wire) (CN6)

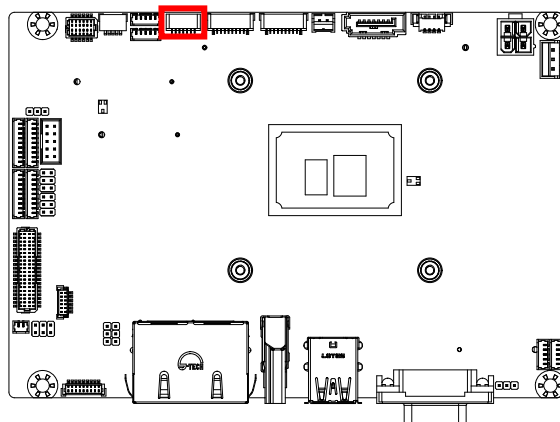

| Pin | Pin Name   | Signal Type | Signal Level |
|-----|------------|-------------|--------------|
| 1   | SPI_MISO   | OUT         | -            |
| 2   | GND        | GND         | GND          |
| 3   | SPI_CLK    | IN          | -            |
| 4   | +V3P3A_SPI | PWR         | +3.3V        |
| 5   | SPI_MOSI   | IN          | -            |
| 6   | SPI_CS     | IN          | -            |
| 7   | NC         | -           | -            |

## 2.4.6 Front Panel (10Pin\*1 Board to Wire) (CN7)

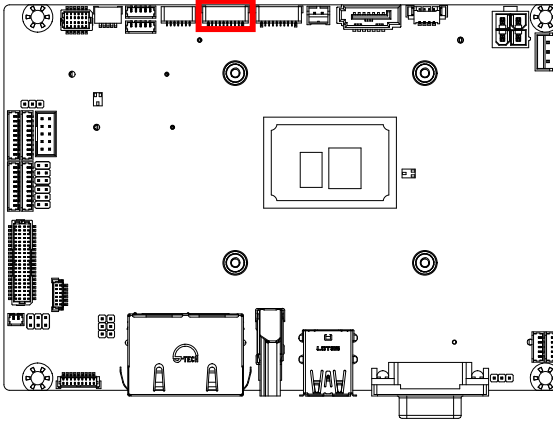

| Pin | Pin Name    | Signal Type | Signal Level |
|-----|-------------|-------------|--------------|
| 1   | GND         | GND         | GND          |
| 2   | EXT_PWRBTN# | IN          | -            |
| 3   | SATA_LED-   | OUT         | -            |
| 4   | SATA_LED+   | OUT         | -            |
| 5   | BUZZER-     | OUT         | -            |
| 6   | BUZZER+     | OUT         | -            |
| 7   | GND         | GND         | GND          |
| 8   | PWR_LED+    | OUT         | -            |
| 9   | GND         | GND         | GND          |
| 10  | HWRST#      | IN          | -            |

## 2.4.7 SMBus/I2C Connector (With SMB\_ALERT/INT\_SERIRQ) (CN8)

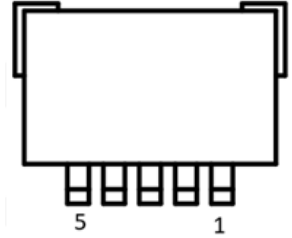
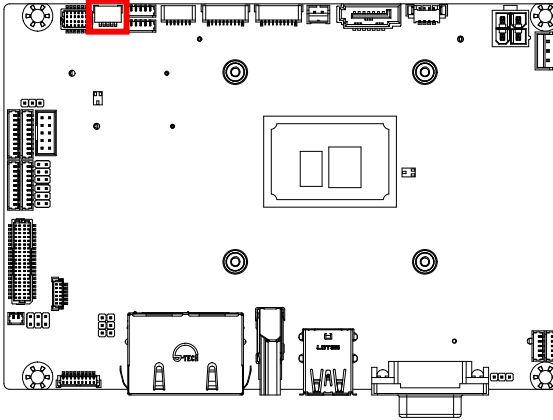

| Pin | Pin Name                         | Signal Type | Signal Level |
|-----|----------------------------------|-------------|--------------|
| 1   | +V3P3S                           | PWR         | +3.3V        |
| 2   | SMB_CLK/<br>I2C_CLK/TIME_SYNC0   | OUT         | +3.3V        |
| 3   | SMB_DAT/<br>I2C_DAT/TIME_SYNC1   | IN/OUT      | +3.3V        |
| 4   | SMB_ALERT/<br>INT_SERIRQ/LAN_SDP | IN          | +3.3V        |
| 5   | GND                              | GND         | GND          |

**Note:** Default function is SMBus.

## 2.4.8 SATA Port (CN9)

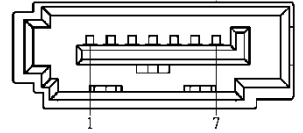
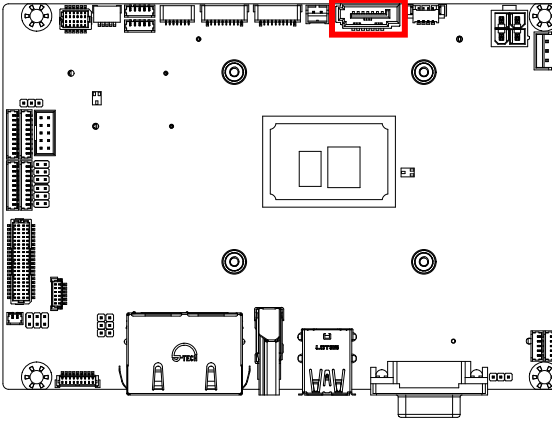

| Pin | Pin Name | Signal Type | Signal Level |
|-----|----------|-------------|--------------|
| 1   | GND      | GND         | GND          |
| 2   | SATA_TXP | DIFF        | -            |
| 3   | SATA_TXN | DIFF        | -            |
| 4   | GND      | GND         | GND          |
| 5   | SATA_RXN | DIFF        | -            |
| 6   | SATA_RXP | DIFF        | -            |
| 7   | GND      | GND         | GND          |

## 2.4.9 Audio In/Out (6Pin\*2 Board to Wire) (CN10)

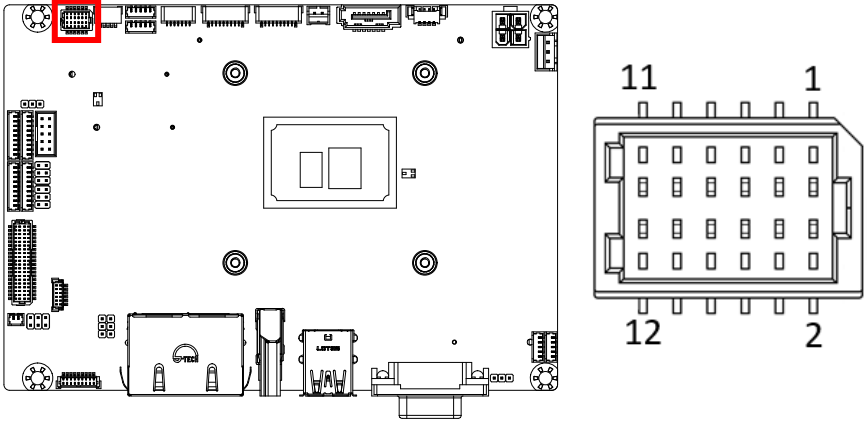

| Pin | Pin Name   | Signal Type | Signal Level |
|-----|------------|-------------|--------------|
| 1   | RIGHT_OUT  | OUT         | -            |
| 2   | MIC_R      | IN          | -            |
| 3   | LEFT_OUT   | OUT         | -            |
| 4   | MIC_L      | IN          | -            |
| 5   | JD_LOUT    | IN          | -            |
| 6   | JD_MIC     | IN          | -            |
| 7   | GND_AUDIO  | GND         | GND          |
| 8   | GND_AUDIO  | GND         | GND          |
| 9   | JD_LIN     | IN          | -            |
| 10  | LINE_R_IN  | IN          | -            |
| 11  | +VDD_AUDIO | PWR         | +5V          |
| 12  | LINE_L_IN  | IN          | -            |

## 2.4.10 USB 2.0 Connector (5Pin\*1 Board to Wire) (CN11)

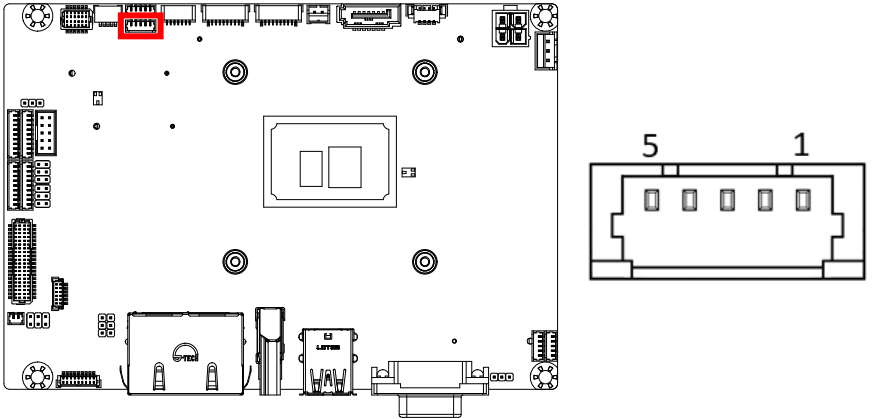

| Pin | Pin Name  | Signal Type | Signal Level |
|-----|-----------|-------------|--------------|
| 1   | +5VSB     | PWR         | +5V          |
| 2   | USB2_6_DN | DIFF        | -            |
| 3   | USB2_6_DP | DIFF        | -            |
| 4   | GND       | GND         | GND          |
| 5   | GND       | GND         | GND          |

**Note:** The driving current of +5VSB supports up to 0.5A/Port.

## 2.4.11 ATX 4-Pin DC Input Socket (CN12)

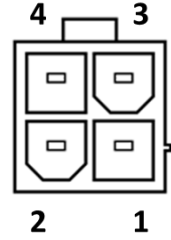
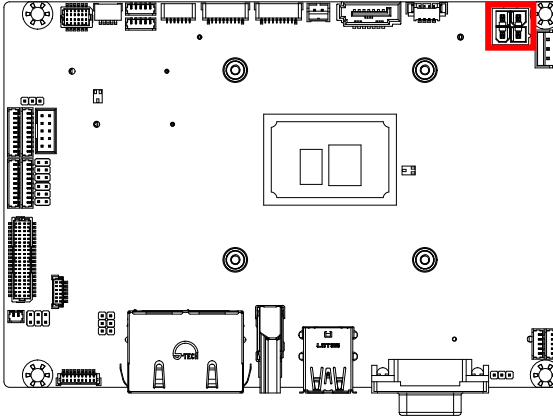

| Pin | Pin Name | Signal Type | Signal Level |
|-----|----------|-------------|--------------|
| 1   | GND      | GND         | GND          |
| 2   | GND      | GND         | GND          |
| 3   | +12V     | PWR         | +12V         |
| 4   | +12V     | PWR         | +12V         |

**Note:** 12V only.

### 2.4.12 Terminal Block DC Input Connector (CN13)

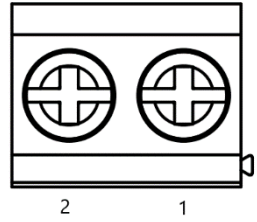
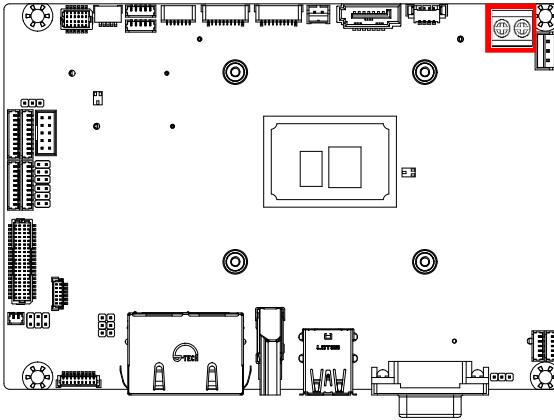

| Pin | Pin Name | Signal Type | Signal Level |
|-----|----------|-------------|--------------|
| 1   | +VIN     | PWR         | +12V         |
| 2   | GND      | GND         | GND          |

### 2.4.13 External +5VSB Input (CN14)

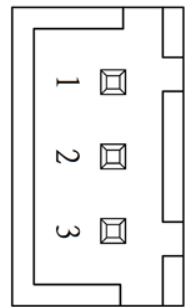
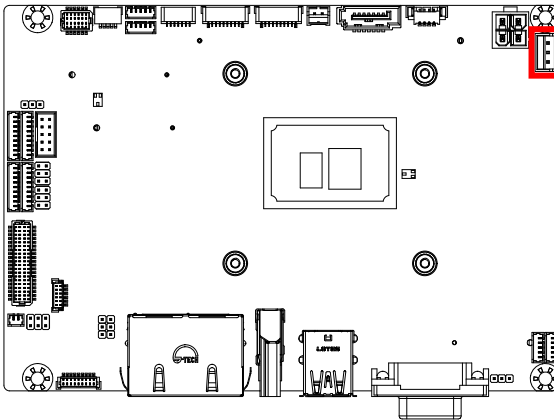

| Pin | Pin Name | Signal Type | Signal Level |
|-----|----------|-------------|--------------|
| 1   | PS_ON#   | OUT         | +5V          |
| 2   | GND      | GND         | GND          |
| 3   | +5VSB    | PWR         | +5V          |

**Note:** The driving current of +5VSB supports up to 2.5A.

### 2.4.14 GPIO Port (5Pin\*2 Board to Wire Type 1) (CN15)

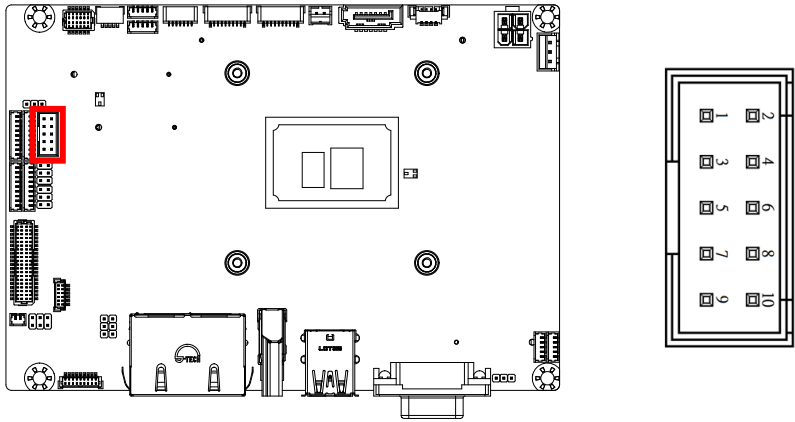

| Pin | Pin Name | Signal Type | Signal Level |
|-----|----------|-------------|--------------|
| 1   | GPIO_0   | IN/OUT      | -            |
| 2   | GPIO_1   | IN/OUT      | -            |
| 3   | GPIO_2   | IN/OUT      | -            |
| 4   | GPIO_3   | IN/OUT      | -            |
| 5   | GPIO_4   | IN/OUT      | -            |
| 6   | GPIO_5   | IN/OUT      | -            |
| 7   | GPIO_6   | IN/OUT      | -            |
| 8   | GPIO_7   | IN/OUT      | -            |
| 9   | +VSS     | PWR         | +5V          |
| 10  | GND      | GND         | GND          |

## 2.4.15 COM Port 3 (9Pin\*1 Board to Wire) (CN16)

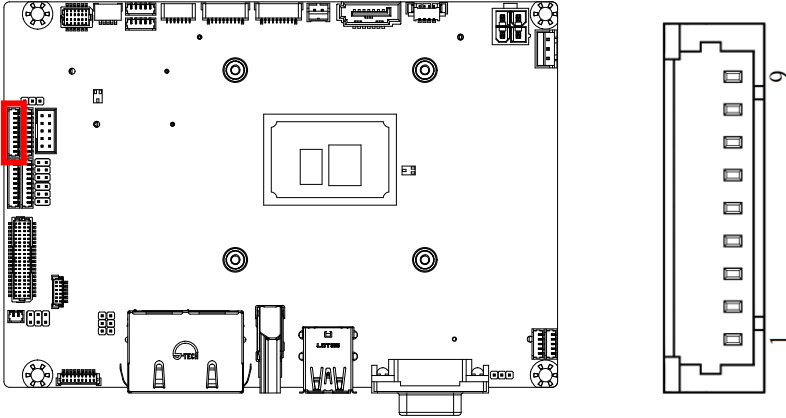

| Pin | Pin Name       | Signal Type | Signal Level |
|-----|----------------|-------------|--------------|
| 1   | DCD1           | IN          | -            |
| 2   | DSR1           | IN          | -            |
| 3   | RX1            | IN          | -            |
| 4   | RTS1           | OUT         | ±9V          |
| 5   | TX1            | OUT         | ±9V          |
| 6   | CTS1           | IN          | -            |
| 7   | DTR1           | OUT         | ±9V          |
| 8   | RI1/ +5V/ +12V | IN/ PWR     | +5V/+12V     |
| 9   | GND            | GND         | GND          |

## 2.4.16 COM Port 4 (9Pin\*1 Board to Wire) (CN17)

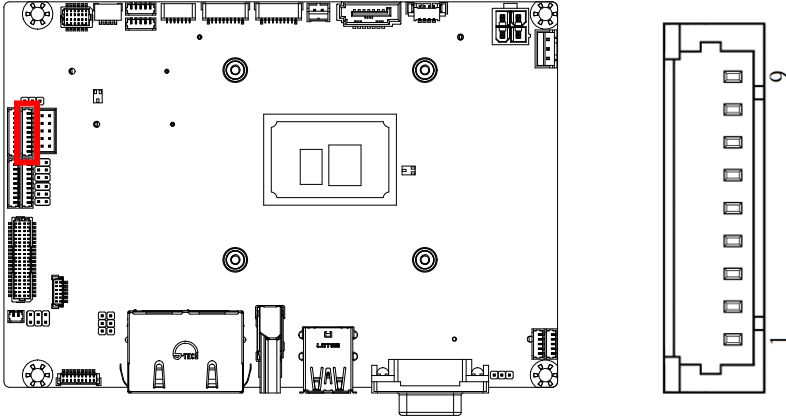

| RS-232 (Default) |                |             |              |
|------------------|----------------|-------------|--------------|
| Pin              | Pin Name       | Signal Type | Signal Level |
| 1                | DCD1           | IN          | -            |
| 2                | DSR1           | IN          | -            |
| 3                | RX1            | IN          | -            |
| 4                | RTS1           | OUT         | ±9V          |
| 5                | TX1            | OUT         | ±9V          |
| 6                | CTS1           | IN          | -            |
| 7                | DTR1           | OUT         | ±9V          |
| 8                | RI1/ +5V/ +12V | IN/ PWR     | +5V/+12V     |
| 9                | GND            | GND         | GND          |

### 2.4.17 COM Port 1 (9Pin\*1 Board to Wire) (CN18)

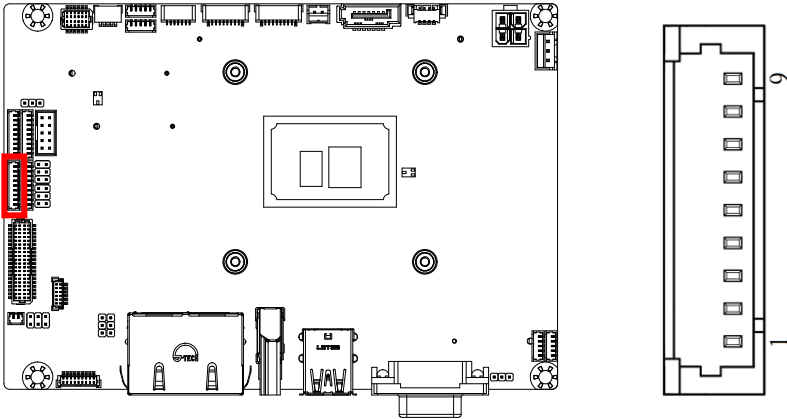

#### RS-232 (Default)

| Pin | Pin Name       | Signal Type | Signal Level |
|-----|----------------|-------------|--------------|
| 1   | DCD1           | IN          | -            |
| 2   | DSR1           | IN          | -            |
| 3   | RX1            | IN          | -            |
| 4   | RTS1           | OUT         | ±9V          |
| 5   | TX1            | OUT         | ±9V          |
| 6   | CTS1           | IN          | -            |
| 7   | DTR1           | OUT         | ±9V          |
| 8   | RI1/ +5V/ +12V | IN/ PWR     | +5V/+12V     |
| 9   | GND            | GND         | GND          |

#### RS-422

| Pin | Pin Name  | Signal Type | Signal Level |
|-----|-----------|-------------|--------------|
| 1   | RS422_TX- | OUT         | ±9V          |
| 2   | NC        | -           | -            |
| 3   | RS422_TX+ | OUT         | ±9V          |
| 4   | NC        | -           | -            |
| 5   | RS422_RX+ | IN          | -            |
| 6   | NC        | -           | -            |
| 7   | RS422_RX- | IN          | -            |
| 8   | NC        | -           | -            |
| 9   | GND       | GND         | GND          |

| RS-485 |          |             |              |
|--------|----------|-------------|--------------|
| Pin    | Pin Name | Signal Type | Signal Level |
| 1      | RS485_D- | IN/OUT      | ±9V          |
| 2      | NC       | -           | -            |
| 3      | RS485_D+ | IN/OUT      | ±9V          |
| 4      | NC       | -           | -            |
| 5      | NC       | -           | -            |
| 6      | NC       | -           | -            |
| 7      | NC       | -           | -            |
| 8      | NC       | -           | -            |
| 9      | GND      | GND         | GND          |

**Note:** COM 1 RS-232/422/485 can be set by BIOS setting. Default is RS-232.

**Note:** Pin 8 function can be set by JP2.

### 2.4.18 COM Port 2 (9Pin\*1 Board to Wire) (CN19)

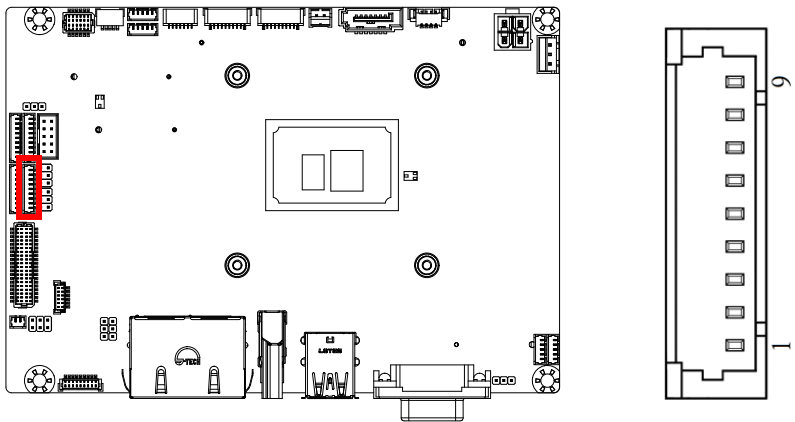

| RS-232 (Default) |          |             |              |
|------------------|----------|-------------|--------------|
| Pin              | Pin Name | Signal Type | Signal Level |
| 1                | DCD1     | IN          | -            |
| 2                | DSR1     | IN          | -            |
| 3                | RX1      | IN          | -            |
| 4                | RTS1     | OUT         | ±9V          |
| 5                | TX1      | OUT         | ±9V          |
| 6                | CTS1     | IN          | -            |

| RS-232 (Default) |                |             |              |
|------------------|----------------|-------------|--------------|
| Pin              | Pin Name       | Signal Type | Signal Level |
| 7                | DTR1           | OUT         | ±9V          |
| 8                | RI1/ +5V/ +12V | IN/ PWR     | +5V/+12V     |
| 9                | GND            | GND         | GND          |
| RS-422           |                |             |              |
| Pin              | Pin Name       | Signal Type | Signal Level |
| 1                | RS422_TX-      | OUT         | ±9V          |
| 2                | NC             | -           | -            |
| 3                | RS422_TX+      | OUT         | ±9V          |
| 4                | NC             | -           | -            |
| 5                | RS422_RX+      | IN          | -            |
| 6                | NC             | -           | -            |
| 7                | RS422_RX-      | IN          | -            |
| 8                | NC             | -           | -            |
| 9                | GND            | GND         | GND          |
| RS-485           |                |             |              |
| Pin              | Pin Name       | Signal Type | Signal Level |
| 1                | RS485_D-       | IN/OUT      | ±9V          |
| 2                | NC             | -           | -            |
| 3                | RS485_D+       | IN/OUT      | ±9V          |
| 4                | NC             | -           | -            |
| 5                | NC             | -           | -            |
| 6                | NC             | -           | -            |
| 7                | NC             | -           | -            |
| 8                | NC             | -           | -            |
| 9                | GND            | GND         | GND          |

**Note:** COM 2 RS-232/422/485 can be set by BIOS setting. Default is RS-232.

**Note:** Pin 8 function can be set by JP3.

### 2.4.19 LVDS/eDP Connector (CN21)

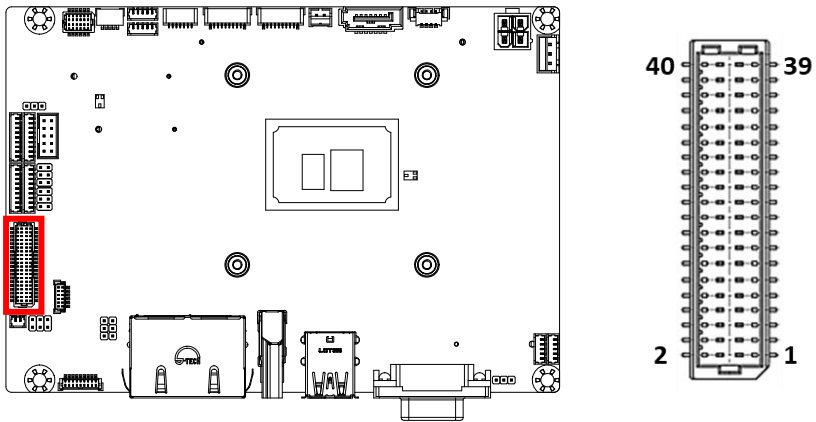

| LVDS (Default) |             |             |              |
|----------------|-------------|-------------|--------------|
| Pin            | Pin Name    | Signal Type | Signal Level |
| 1              | BKL_ENABLE  | OUT         | -            |
| 2              | BKL_CONTROL | OUT         | -            |
| 3              | GND         | GND         | GND          |
| 4              | GND         | GND         | GND          |
| 5              | LVDS_A_CLK- | DIFF        | -            |
| 6              | LCD_PWR     | PWR         | +3.3V/+5V    |
| 7              | LVDS_A_CLK+ | DIFF        | -            |
| 8              | LCD_PWR     | PWR         | +3.3V/+5V    |
| 9              | GND         | GND         | GND          |
| 10             | GND         | GND         | GND          |
| 11             | LVDS_DA0-   | DIFF        | -            |
| 12             | LVDS_DA2-   | DIFF        | -            |
| 13             | LVDS_DA0+   | DIFF        | -            |
| 14             | LVDS_DA2+   | DIFF        | -            |
| 15             | GND         | GND         | GND          |
| 16             | GND         | GND         | GND          |
| 17             | LVDS_DA1-   | DIFF        | -            |
| 18             | LVDS_DA3-   | DIFF        | -            |
| 19             | LVDS_DA1+   | DIFF        | -            |
| 20             | LVDS_DA3+   | DIFF        | -            |
| 21             | GND         | GND         | GND          |

| LVDS (Default) |             |             |              |
|----------------|-------------|-------------|--------------|
| Pin            | Pin Name    | Signal Type | Signal Level |
| 22             | GND         | GND         | GND          |
| 23             | LVDS_DB0-   | DIFF        | -            |
| 24             | DDC_DATA    | OUT         | +3.3V        |
| 25             | LVDS_DB0+   | DIFF        | -            |
| 26             | DDC_CLK     | IN          | +3.3V        |
| 27             | GND         | GND         | GND          |
| 28             | GND         | GND         | GND          |
| 29             | LVDS_DB1-   | DIFF        | -            |
| 30             | LVDS_DB2-   | DIFF        | -            |
| 31             | LVDS_DB1+   | DIFF        | -            |
| 32             | LVDS_DB2+   | DIFF        | -            |
| 33             | GND         | GND         | GND          |
| 34             | GND         | GND         | GND          |
| 35             | LVDS_B_CLK- | DIFF        | -            |
| 36             | LVDS_DB3-   | DIFF        | -            |
| 37             | LVDS_B_CLK+ | DIFF        | -            |
| 38             | LVDS_DB3+   | DIFF        | -            |
| 39             | NC          |             | -            |
| 40             | NC          |             | -            |

| eDP |             |             |              |
|-----|-------------|-------------|--------------|
| Pin | Pin Name    | Signal Type | Signal Level |
| 1   | BKL_ENABLE  | OUT         | -            |
| 2   | BKL_CONTROL | OUT         | -            |
| 3   | GND         | GND         | GND          |
| 4   | GND         | GND         | GND          |
| 5   | eDP_TXN3    | DIFF        | -            |
| 6   | LCD_PWR     | PWR         | +3.3V/+5V    |
| 7   | eDP_TXP3    | DIFF        | -            |
| 8   | LCD_PWR     | PWR         | +3.3V/+5V    |
| 9   | GND         | GND         | GND          |
| 10  | GND         | GND         | GND          |
| 11  | eDP_TXN2    | DIFF        | -            |
| 12  | eDP_TXN0    | DIFF        | -            |
| 13  | eDP_TXP2    | DIFF        | -            |
| 14  | eDP_TXP0    | DIFF        | -            |
| 15  | GND         | GND         | GND          |
| 16  | GND         | GND         | GND          |

| eDP |           |             |              |
|-----|-----------|-------------|--------------|
| Pin | Pin Name  | Signal Type | Signal Level |
| 17  | eDP_TXN1  | DIFF        | -            |
| 18  | NC        |             |              |
| 19  | eDP_TXP1  | DIFF        | -            |
| 20  | NC        |             |              |
| 21  | GND       | GND         | GND          |
| 22  | GND       | GND         | GND          |
| 23  | NC        |             |              |
| 24  | eDP_AUX_N | DIFF        |              |
| 25  | NC        |             |              |
| 26  | eDP_AUX_P | DIFF        |              |
| 27  | GND       | GND         | GND          |
| 28  | GND       | GND         | GND          |
| 29  | NC        |             | -            |
| 30  | NC        |             | -            |
| 31  | NC        |             | -            |
| 32  | NC        |             | -            |
| 33  | GND       | GND         | GND          |
| 34  | GND       | GND         | GND          |
| 35  | NC        |             | -            |
| 36  | NC        |             | -            |
| 37  | NC        |             | -            |
| 38  | NC        |             | -            |
| 39  | eDP_HPD   | IN          | -            |
| 40  | NC        |             | -            |

## 2.4.20 LVDS Inverter/Backlight Connector (6Pin\*1 Board to Wire) (CN22)

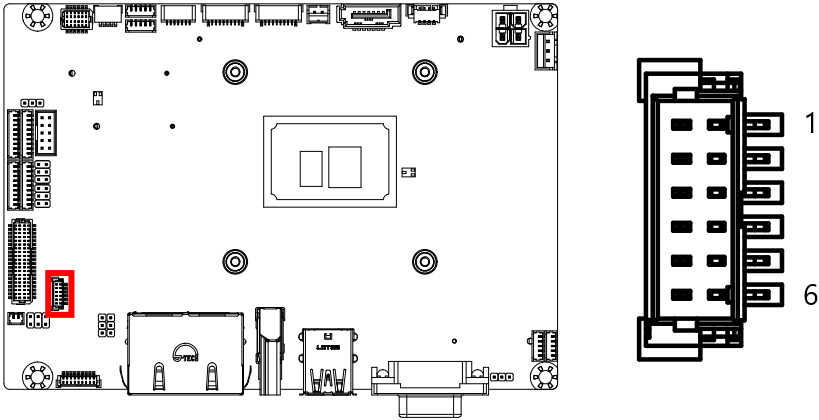

| Pin | Pin Name    | Signal Type | Signal Level      |
|-----|-------------|-------------|-------------------|
| 1   | BKL_PWR     | PWR         | +5V(Default)/+12V |
| 2   | BKL_PWR     | PWR         | +5V(Default)/+12V |
| 3   | BKL_CONTROL | OUT         | -                 |
| 4   | GND         | GND         | GND               |
| 5   | GND         | GND         | GND               |
| 6   | BKL_ENABLE  | OUT         | +3.3V             |

**Note:** LVDS/BKL\_PWR can be set to +12V or +5V by BOM. Stuff R285 for 12V and stuff R287 for 5V. [Default:12V]

**Note:** The driving current of BKL\_PWR supports up to 2A.

### 2.4.21 RTC Battery Connector (CN23)

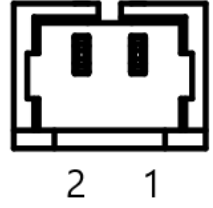
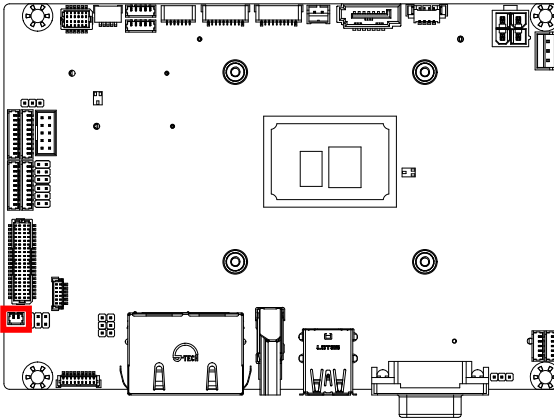

| Pin | Pin Name | Signal Type | Signal Level |
|-----|----------|-------------|--------------|
| 1   | +3.3V    | PWR         | +3.3V        |
| 2   | GND      | GND         | GND          |

### 2.4.22 USB 2.0 Connector (5Pin\*1 Board to Wire) (CN24)

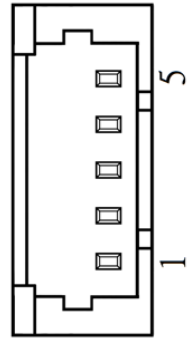
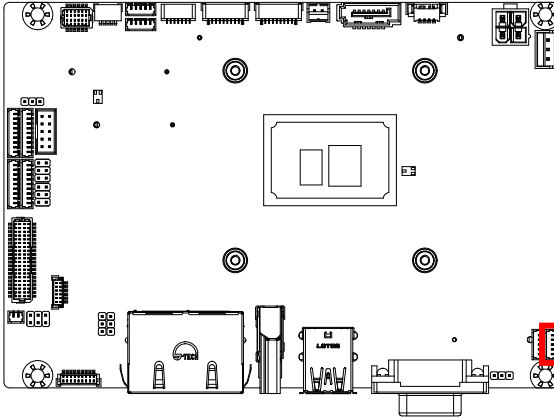

| Pin | Pin Name  | Signal Type | Signal Level |
|-----|-----------|-------------|--------------|
| 1   | +5VSB     | PWR         | +5V          |
| 2   | USB2_6_DN | DIFF        | -            |
| 3   | USB2_6_DP | DIFF        | -            |
| 4   | GND       | GND         | GND          |
| 5   | GND       | GND         | GND          |

**Note:** The driving current of +5VSB supports up to 0.5A/Port.

### 2.4.23 USB 2.0 Connector (5Pin\*1 Board to Wire) (CN25)

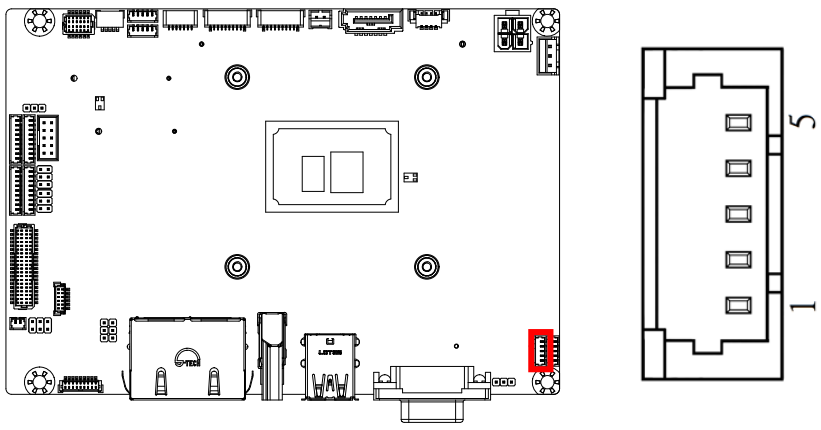

| Pin | Pin Name  | Signal Type | Signal Level |
|-----|-----------|-------------|--------------|
| 1   | +5VSB     | PWR         | +5V          |
| 2   | USB2_6_DN | DIFF        | -            |
| 3   | USB2_6_DP | DIFF        | -            |
| 4   | GND       | GND         | GND          |
| 5   | GND       | GND         | GND          |

**Note:** The driving current of +5VSB supports up to 0.5A/Port.

## 2.4.24 HDMI Port (CN26)

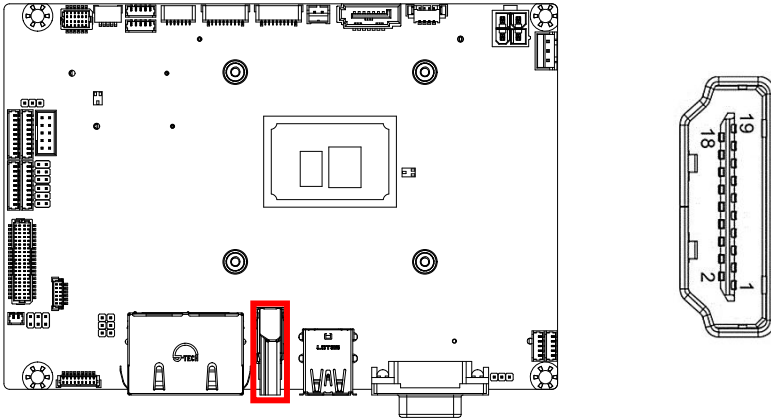

| Pin | Pin Name  | Signal Type | Signal Level |
|-----|-----------|-------------|--------------|
| 1   | HDMI_TX2+ | DIFF        | -            |
| 2   | GND       | GND         | GND          |
| 3   | HDMI_TX2- | DIFF        | -            |
| 4   | HDMI_TX1+ | DIFF        | -            |
| 5   | GND       | GND         | GND          |
| 6   | HDMI_TX1- | DIFF        | -            |
| 7   | HDMI_TX0+ | DIFF        | -            |
| 8   | GND       | GND         | GND          |
| 9   | HDMI_TX0- | DIFF        | -            |
| 10  | HDMI_CLK+ | DIFF        | -            |
| 11  | GND       | GND         | GND          |
| 12  | HDMI_CLK- | DIFF        | -            |
| 13  | N/A       | N/A         | N/A          |
| 14  | N/A       | N/A         | N/A          |
| 15  | DDC_CLK   | IN/OUT      | -            |
| 16  | DDC_DATA  | IN/OUT      | -            |
| 17  | GND       | GND         | GND          |
| 18  | +V5S      | PWR         | +5V          |
| 19  | HDMI_HPD  | IN          | -            |

## 2.4.25 Dual RJ-45 LAN Port (CN28)

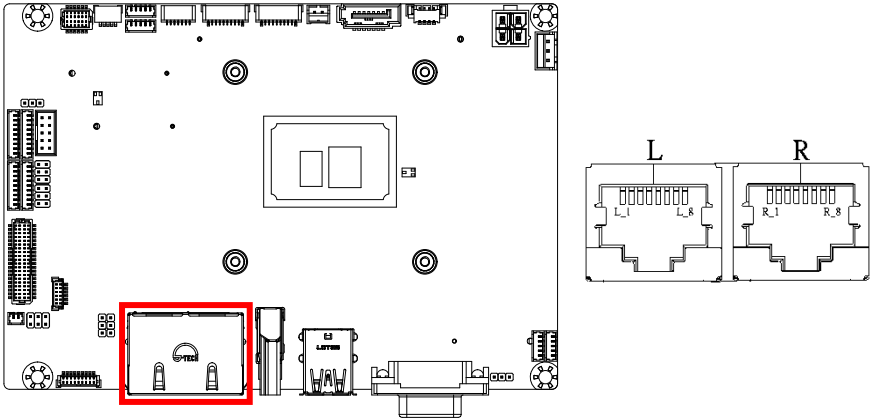

| Pin | Pin Name    | Signal Type | Signal Level |
|-----|-------------|-------------|--------------|
| L_1 | LAN1_MDI0_P | DIFF        | -            |
| L_2 | LAN1_MDI0_N | DIFF        | -            |
| L_3 | LAN1_MDI1_P | DIFF        | -            |
| L_4 | LAN1_MDI1_N | DIFF        | -            |
| L_5 | LAN1_MDI2_P | DIFF        | -            |
| L_6 | LAN1_MDI2_N | DIFF        | -            |
| L_7 | LAN1_MDI3_P | DIFF        | -            |
| L_8 | LAN1_MDI3_N | DIFF        | -            |
| R_1 | LAN2_MDI0_P | DIFF        | -            |
| R_2 | LAN2_MDI0_N | DIFF        | -            |
| R_3 | LAN2_MDI1_P | DIFF        | -            |
| R_4 | LAN2_MDI1_N | DIFF        | -            |
| R_5 | LAN2_MDI2_P | DIFF        | -            |
| R_6 | LAN2_MDI2_N | DIFF        | -            |
| R_7 | LAN2_MDI3_P | DIFF        | -            |
| R_8 | LAN2_MDI3_N | DIFF        | -            |

## 2.4.26 USB 3.2/USB 2.0 Port 1/Port 2 (CN29)

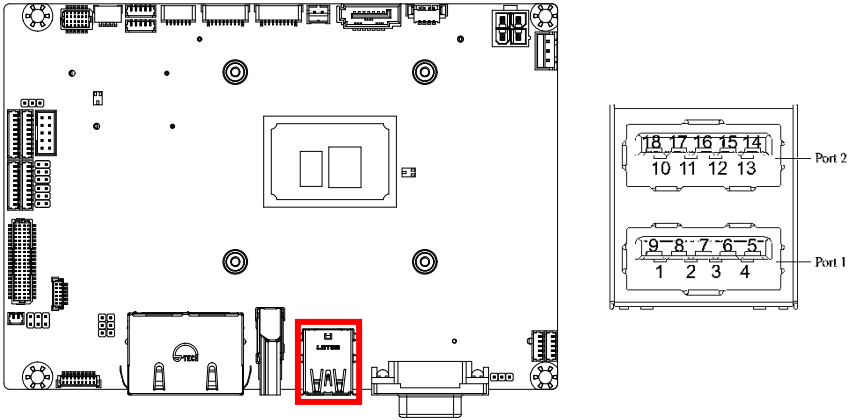

| Pin | Pin Name   | Signal Type | Signal Level |
|-----|------------|-------------|--------------|
| 1   | +5VSB      | PWR         | +5V          |
| 2   | USB2_1_DN  | DIFF        | -            |
| 3   | USB2_1_DP  | DIFF        | -            |
| 4   | GND        | GND         | GND          |
| 5   | USB3_1_RXN | DIFF        | -            |
| 6   | USB3_1_RXP | DIFF        | -            |
| 7   | GND        | GND         | GND          |
| 8   | USB3_1_TXN | DIFF        | -            |
| 9   | USB3_1_TXP | DIFF        | -            |
| 10  | +5VSB      | PWR         | +5V          |
| 11  | USB2_2_DN  | DIFF        | -            |
| 12  | USB2_2_DP  | DIFF        | -            |
| 13  | GND        | GND         | GND          |
| 14  | USB3_2_RXN | DIFF        | -            |
| 15  | USB3_2_RXP | DIFF        | -            |
| 16  | GND        | GND         | GND          |
| 17  | USB3_2_TXN | DIFF        | -            |
| 18  | USB3_2_TXP | DIFF        | -            |

**Note:** The driving current of +5VSB supports up to 0.9A/Port.

### 2.4.27 IMVP9 FW Reflash (CN30)

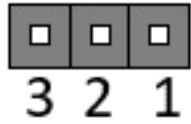
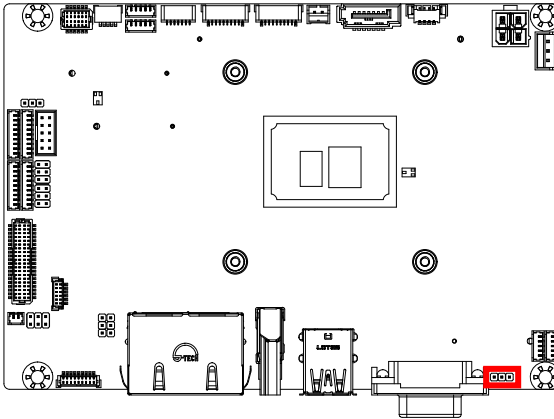

| Pin | Pin Name | Signal Type | Signal Level |
|-----|----------|-------------|--------------|
| 1   | PM_SCL   | I/O         | +3.3V        |
| 2   | PM_DAT   | OUT         | +3.3V        |
| 3   | GND      | GND         |              |

### 2.4.28 Touch Screen Lines (CN31)

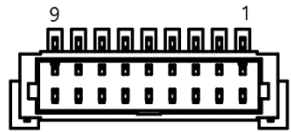
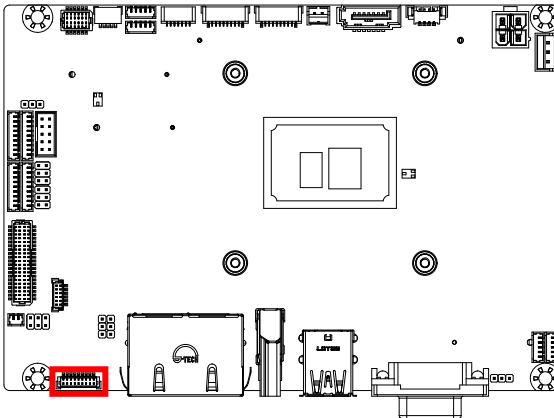

| Pin | Pin Name      | Signal Type | Signal Level |
|-----|---------------|-------------|--------------|
| 1   | GND           | GND         | GND          |
| 2   | Top Excite    | IN/OUT      |              |
| 3   | Bottom Excite | IN/OUT      |              |
| 4   | Left Excite   | IN/OUT      |              |
| 5   | Right Excite  | IN/OUT      |              |
| 6   | TOP Sense     | IN/OUT      |              |
| 7   | Bottom Sense  | IN/OUT      |              |
| 8   | Left Sense    | IN/OUT      |              |
| 9   | Right Sense   | IN/OUT      |              |

### 2.4.29 VGA Port (CN32)

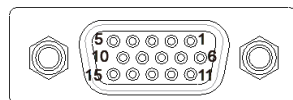
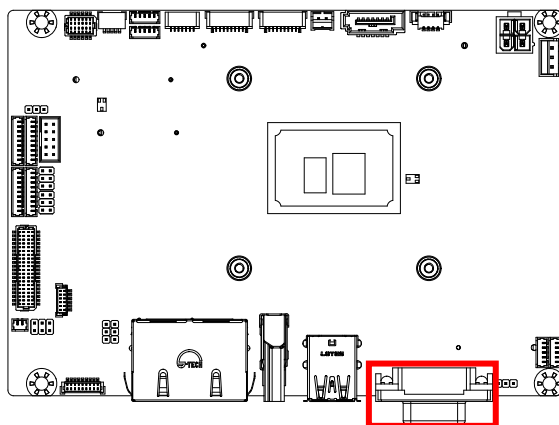

| Pin | Pin Name      | Signal Type | Signal Level |
|-----|---------------|-------------|--------------|
| 1   | RED           | OUT         |              |
| 2   | GREEN         | OUT         |              |
| 3   | BLUE          | OUT         |              |
| 4   | NC            |             |              |
| 5   | GND           | GND         | GND          |
| 6   | RED_GND_RTN   | GND         | GND          |
| 7   | GREEN_GND_RTN | GND         | GND          |
| 8   | BLUE_GND_RTN  | GND         | GND          |
| 9   | +5V           | PWR         | +5V          |
| 10  | GND           | GND         | GND          |

| Pin | Pin Name | Signal Type | Signal Level |
|-----|----------|-------------|--------------|
| 11  | NC       |             |              |
| 12  | DDC_DATA | I/O         | +5V          |
| 13  | HSYNC    | OUT         |              |
| 14  | VSYNC    | OUT         |              |
| 15  | DDC_CLK  | I/O         | +5V          |

### 2.4.30 DDR5 SODIMM Slot (CN33)

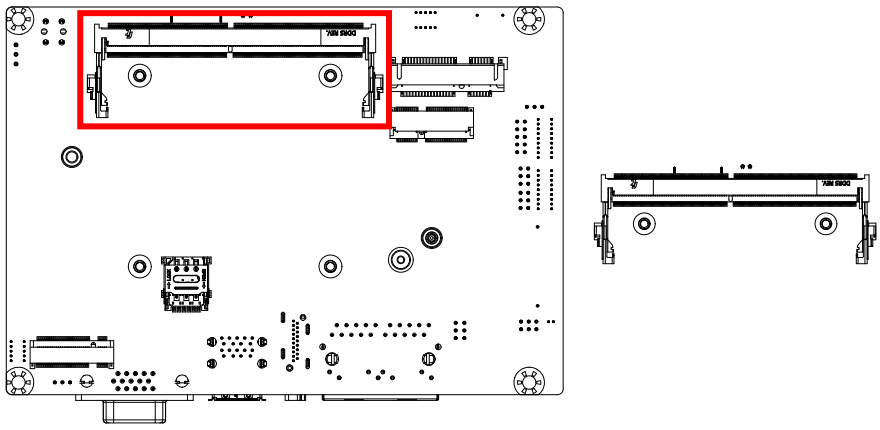

Standard specifications.

## 2.4.31 Mini Card Slot (Full-size mSATA/mPCIe) (CN34)

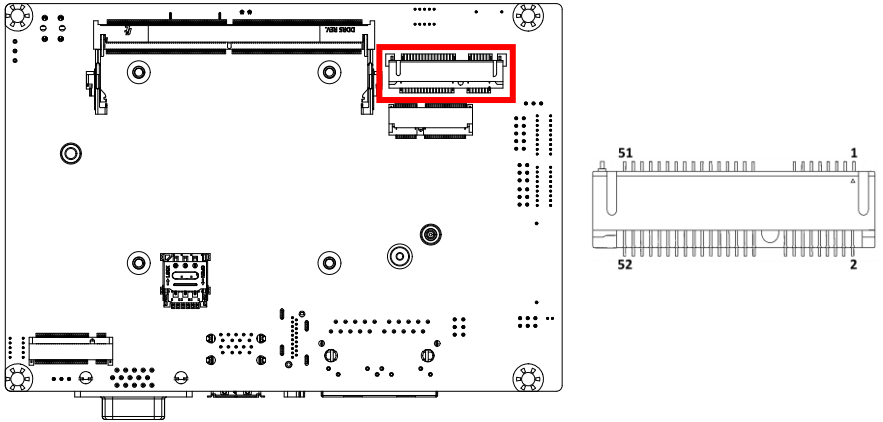

| Pin | Pin Name      | Signal Type | Signal Level |
|-----|---------------|-------------|--------------|
| 1   | PCIE_WAKE#    | IN          | -            |
| 2   | +3.3V         | PWR         | +3.3V        |
| 3   | NC            | NC          | NC           |
| 4   | GND           | GND         | GND          |
| 5   | NC            | NC          | NC           |
| 6   | +1.5V         | PWR         | +1.5V        |
| 7   | PCIE_CLK_REQ# | IN          | -            |
| 8   | NC            | NC          | NC           |
| 9   | GND           | GND         | GND          |
| 10  | NC            | NC          | NC           |
| 11  | PCIE_REF_CLK- | DIFF        | -            |
| 12  | NC            | NC          | NC           |
| 13  | PCIE_REF_CLK+ | DIFF        | -            |
| 14  | NC            | NC          | NC           |
| 15  | GND           | GND         | GND          |
| 16  | NC            | NC          | NC           |
| 17  | NC            | NC          | NC           |
| 18  | GND           | GND         | GND          |
| 19  | NC            | NC          | NC           |
| 20  | W_DISABLE#    | OUT         | +3.3V        |
| 21  | GND           | GND         | GND          |
| 22  | PCIE_RST3     | OUT         | +3.3V        |

| Pin | Pin Name          | Signal Type | Signal Level |
|-----|-------------------|-------------|--------------|
| 23  | PCIE_RX-/SATA_RX- | DIFF        | GND          |
| 24  | +3.3V             | PWR         | +3.3V        |
| 25  | PCIE_RX+/SATA_RX+ | DIFF        | -            |
| 26  | GND               | GND         | GND          |
| 27  | GND               | GND         | GND          |
| 28  | +1.5V             | PWR         | +1.5V        |
| 29  | GND               | GND         | GND          |
| 30  | SMB_CLK           | IN/OUT      | +3.3V        |
| 31  | PCIE_TX-/SATA_TX- | DIFF        | -            |
| 32  | SMB_DATA          | IN/OUT      | +3.3V        |
| 33  | PCIE_TX+/SATA_TX+ | DIFF        | -            |
| 34  | GND               | GND         | GND          |
| 35  | GND               | GND         | GND          |
| 36  | USB_D-            | DIFF        | -            |
| 37  | GND               | GND         | GND          |
| 38  | USB_D+            | DIFF        | -            |
| 39  | +3.3V             | PWR         | +3.3V        |
| 40  | GND               | GND         | GND          |
| 41  | +3.3V             | PWR         | +3.3V        |
| 42  | NC                | NC          | NC           |
| 43  | GND               | GND         | GND          |
| 44  | NC                | NC          | NC           |
| 45  | NC                | NC          | NC           |
| 46  | NC                | NC          | NC           |
| 47  | NC                | NC          | NC           |
| 48  | +1.5V             | PWR         | +1.5V        |
| 49  | NC                | NC          | NC           |
| 50  | GND               | GND         | GND          |
| 51  | NC                | NC          | NC           |
| 52  | +3.3V             | PWR         | +3.3V        |

**Note:** This is a co-lay design from PICO-V2K4, check pin define before use.

Mini-Card/mSATA function can be set by BIOS. Default is mSATA.

## 2.4.32 M.2 2230 E-Key Slot (CN35)

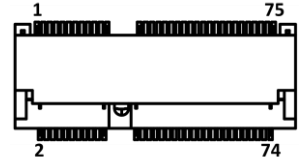
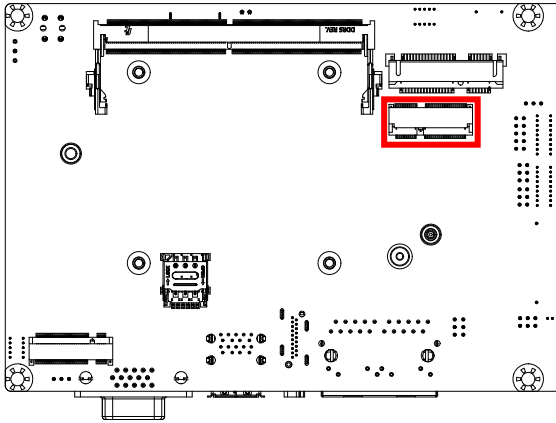

| Pin | Pin Name         | Signal Type | Signal Level |
|-----|------------------|-------------|--------------|
| 1   | GND              | GND         | GND          |
| 2   | +V3P3A           | PWR         | +3.3V        |
| 3   | USB2_10_DP       | DIFF        | -            |
| 4   | +V3P3A           | PWR         | +3.3V        |
| 5   | USB2_10_DN       | DIFF        | -            |
| 6   | NC               | -           | -            |
| 7   | GND              | GND         | GND          |
| 8   | NC               | -           | -            |
| 9   | CNV_WR_D1_DN     | DIFF        | -            |
| 10  | KEYE_CNV_RF_RST  | IN          | -            |
| 11  | CNV_WR_D1_DP     | DIFF        | -            |
| 12  | NC               | -           | -            |
| 13  | GND              | GND         | GND          |
| 14  | KEYE_CNV_CLKREQ  | OUT         | -            |
| 15  | CNV_WR_D0_DN     | DIFF        | -            |
| 16  | NC               | -           | -            |
| 17  | CNV_WR_D0_DP     | DIFF        | -            |
| 18  | GND              | GND         | GND          |
| 19  | GND              | GND         | GND          |
| 20  | KEYE_UART_WAKE_N | IN          | -            |
| 21  | CNV_WR_CLK_DN    | DIFF        | -            |
| 22  | CNV_BRI_RSP      | IN          | -            |

| Pin | Pin Name      | Signal Type | Signal Level |
|-----|---------------|-------------|--------------|
| 23  | CNV_WR_CLK_DP | DIFF        | -            |
| 32  | CNV_RGI_DT    | IN          | -            |
| 33  | GND           | GND         | GND          |
| 34  | CNV_RGI_RSP   | OUT         | -            |
| 35  | PCIE_8_TXP    | DIFF        | -            |
| 36  | CNV_BRI_DT    | -           | -            |
| 37  | PCIE_8_TXN    | DIFF        | -            |
| 38  | MLK_RST_N     | IN          | -            |
| 39  | GND           | GND         | GND          |
| 40  | MLK_DATA      | IN/OUT      | -            |
| 41  | PCIE_8_RXP    | DIFF        | -            |
| 42  | MLK_CLK       | IN          | -            |
| 43  | PCIE_8_RXN    | DIFF        | -            |
| 44  | NC            | -           | -            |
| 45  | GND           | GND         | GND          |
| 46  | NC            | -           | -            |
| 47  | PCIE_3_CLK_DP | DIFF        | -            |
| 48  | NC            | -           | -            |
| 49  | PCIE_3_CLK_DN | DIFF        | -            |
| 50  | SUS_CLK       | IN          | -            |
| 51  | GND           | GND         | GND          |
| 52  | BUF_PLT_RST#  | IN          | -            |
| 53  | PCIE_CLKREQ#3 | OUT         | -            |
| 54  | NC            | -           | -            |
| 55  | PCIE_WAKE#    | IN/OUT      | -            |
| 56  | NC            | -           | -            |
| 57  | GND           | GND         | GND          |
| 58  | NC            | -           | -            |
| 59  | CNV_WT_D1_DN  | DIFF        | -            |
| 60  | NC            | -           | -            |
| 61  | CNV_WT_D1_DP  | DIFF        | -            |
| 62  | NC            | -           | -            |
| 63  | GND           | GND         | GND          |
| 64  | NC            | -           | -            |
| 65  | CNV_WT_D0_DN  | DIFF        | -            |
| 66  | NC            | -           | -            |
| 67  | CNV_WT_D0_DP  | DIFF        | -            |
| 68  | NC            | -           | -            |
| 69  | GND           | GND         | GND          |

| Pin | Pin Name      | Signal Type | Signal Level |
|-----|---------------|-------------|--------------|
| 70  | NC            | -           | -            |
| 71  | CNV_WT_CLK_DN | DIFF        | -            |
| 72  | +V3P3A        | PWR         | +3.3V        |
| 73  | CNV_WT_CLK_DP | DIFF        | -            |
| 74  | +V3P3A        | PWR         | +3.3V        |
| 75  | GND           | GND         | GND          |

### 2.4.33 Nano SIM Card Slot (CN36)

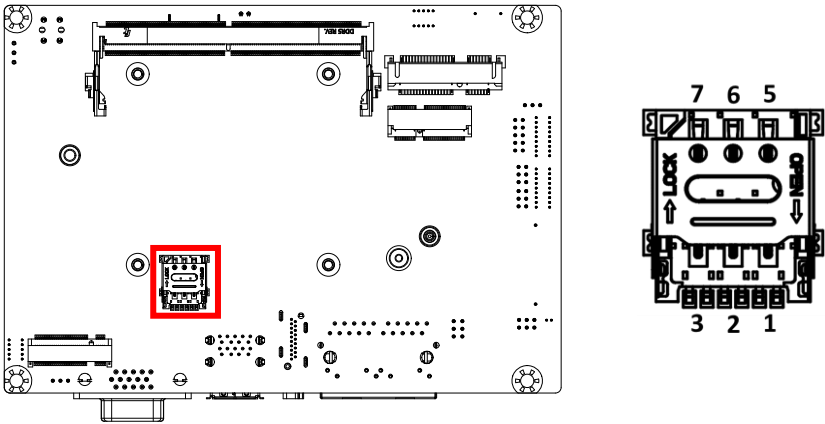

| Pin | Pin Name | Signal Type | Signal Level |
|-----|----------|-------------|--------------|
| 1   | UIM_PWR  | PWR         | -            |
| 2   | UIM_RST  | OUT         | -            |
| 3   | UIM_CLK  | OUT         | -            |
| 4   | N/A      | N/A         | -            |
| 5   | GND      | GND         | GND          |
| 6   | N/A      | N/A         | -            |
| 7   | UIM_DATA | IN/OUT      | -            |

## 2.4.34 M.2 3052 B-Key Slot (CN37)

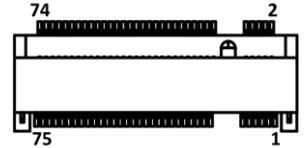
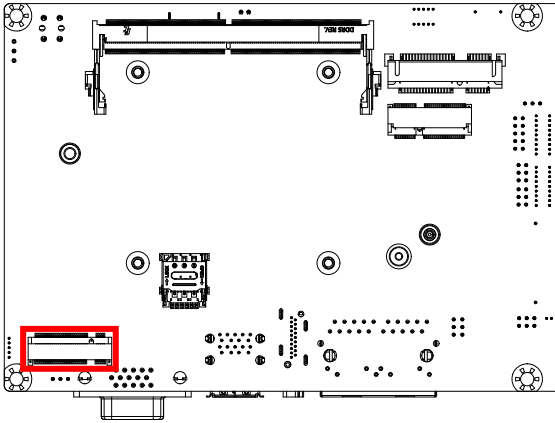

| Pin | Pin Name                  | Signal Type | Signal Level |
|-----|---------------------------|-------------|--------------|
| 1   | NC                        |             |              |
| 2   | +V3P3S                    | PWR         | +3.3V        |
| 3   | GND                       | GND         | GND          |
| 4   | +V3P3S                    | PWR         | +3.3V        |
| 5   | GND                       | GND         | GND          |
| 6   | NC                        |             |              |
| 7   | USB2_2_DP                 | DIFF        | -            |
| 8   | KEYB_DISABLE_N            | IN          |              |
| 9   | USB2_2_DN                 | DIFF        | -            |
| 10  | PCH_SATA_LED_N            | OUT         | +3.3V        |
| 11  | GND                       | GND         | GND          |
| 20  | NC                        | -           | -            |
| 21  | NC                        | -           | -            |
| 22  | NC                        | -           | -            |
| 23  | NC                        | -           | -            |
| 24  | NC                        | -           | -            |
| 25  | NC                        | -           | -            |
| 26  | NC                        | -           | -            |
| 27  | GND                       | GND         | GND          |
| 28  | NC                        | -           | -            |
| 29  | PCIE_4_RXN/<br>USB3_2_RXN | DIFF        | -            |

| Pin | Pin Name                   | Signal Type | Signal Level |
|-----|----------------------------|-------------|--------------|
| 30  | UIM_RST_M2B                | OUT         | -            |
| 31  | PCIE4_1_RXP/<br>USB3_2_RXP | DIFF        | -            |
| 32  | UIM_CLK_M2B                | -           | -            |
| 33  | GND                        | GND         | GND          |
| 34  | UIM_DAT_M2B                | IN/OUT      | -            |
| 35  | PCIE4_TXN/<br>USB3_2_TXN   | DIFF        | -            |
| 36  | UIM_PWR                    | PWR         | -            |
| 37  | PCIE4_TXP/<br>USB3_2_TXP   | DIFF        | -            |
| 38  | NC                         | -           | -            |
| 39  | GND                        | GND         | GND          |
| 40  | NC                         | -           | -            |
| 41  | PCIE_3_RXN                 | DIFF        | -            |
| 42  | NC                         | -           | -            |
| 43  | PCIE_3_RXP                 | DIFF        | -            |
| 44  | NC                         | -           | -            |
| 45  | GND                        | GND         | GND          |
| 46  | NC                         | -           | -            |
| 47  | PCIE_3_TXN                 | DIFF        | -            |
| 48  | NC                         | -           | -            |
| 49  | PCIE_3_TXP                 | DIFF        | -            |
| 50  | BUF_PLT_RST#               | OUT         | -            |
| 51  | GND                        | GND         | GND          |
| 52  | M2B_CLKREQ#                | IN          | -            |
| 53  | PCIE_4_CLK_DN              | DIFF        | -            |
| 54  | KEYB_WAKE_N                | IN          | -            |
| 55  | PCIE_4_CLK_DN              | DIFF        | -            |
| 56  | NC                         | -           | -            |
| 57  | GND                        | GND         | GND          |
| 58  | NC                         | -           | -            |
| 59  | NC                         | -           | -            |
| 60  | NC                         | -           | -            |
| 61  | NC                         | -           | -            |
| 62  | NC                         | -           | -            |
| 63  | NC                         | -           | -            |
| 64  | NC                         | -           | -            |
| 65  | NC                         | -           | -            |

| Pin | Pin Name        | Signal Type | Signal Level |
|-----|-----------------|-------------|--------------|
| 66  | SIM_Detect      | IN          | -            |
| 67  | KEYB_WWAN_RST_N | OUT         | -            |
| 68  | PCH_SUS_CLK     | IN          | -            |
| 69  | NC              | -           | -            |
| 70  | +V3P3A          | PWR         | +3.3V        |
| 71  | GND             | GND         | GND          |
| 72  | +V3P3A          | PWR         | +3.3V        |
| 73  | GND             | GND         | GND          |
| 74  | +V3P3A          | PWR         | +3.3V        |
| 75  | NC              | -           | -            |

## 2.5 Thermal Solutions

### 2.5.1 Heatsink

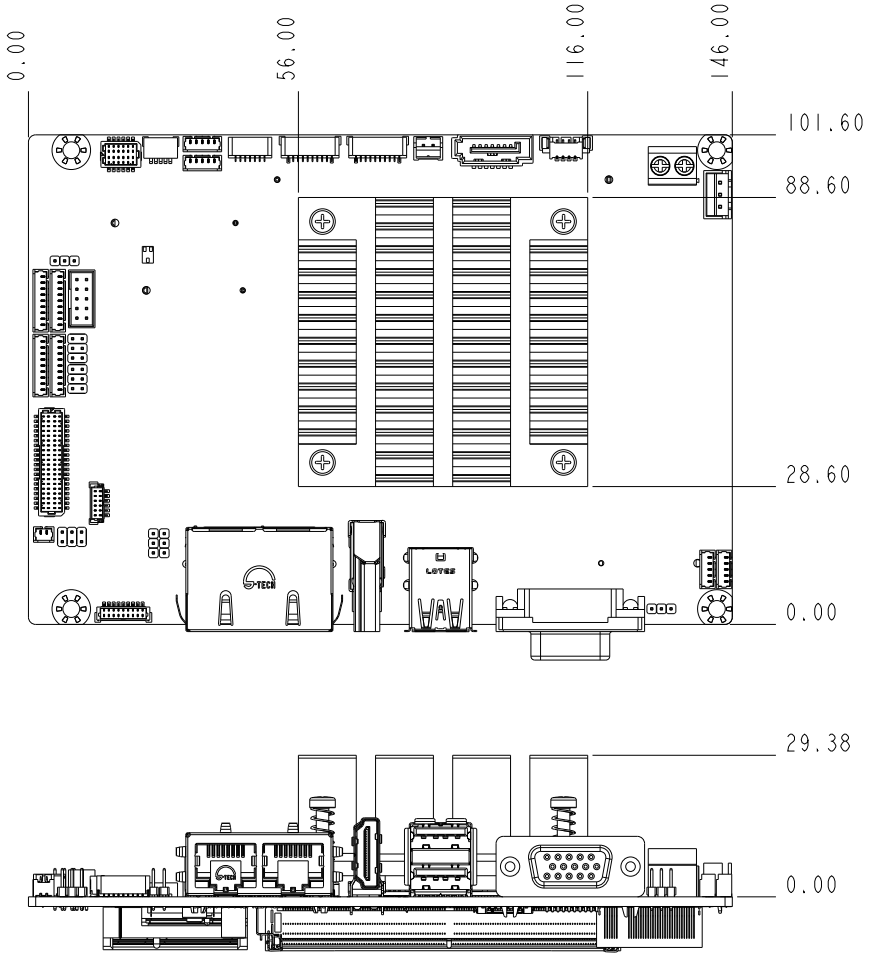

# Heatsink Assembly

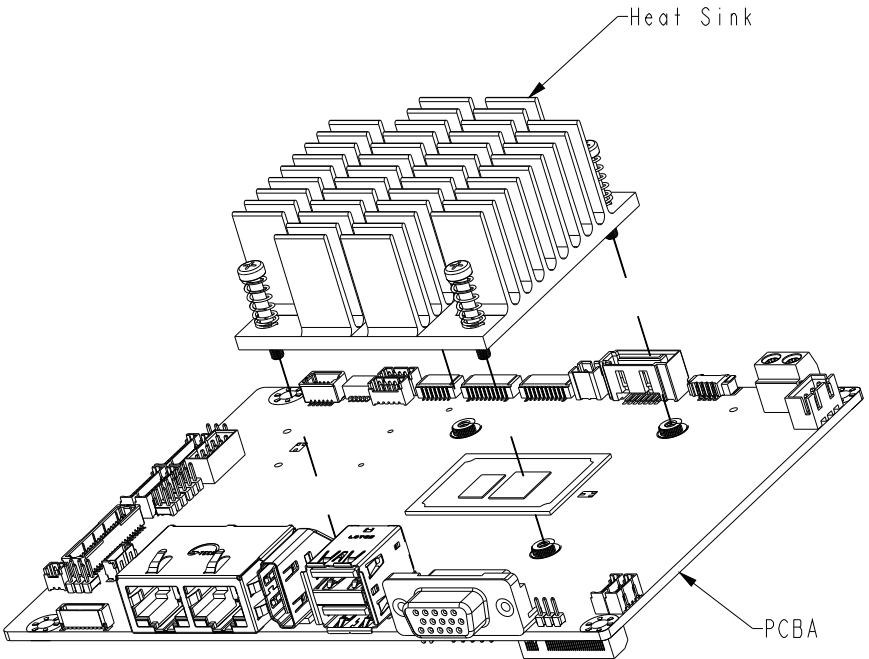

# Chapter 3

---

AMI BIOS Setup

## 3.1 System Test and Initialization

---

These routines test and initialize board hardware. If the routines encounter an error during the tests, you will either hear a few short beeps or see an error message on the screen. There are two kinds of errors: fatal and non-fatal. The system can usually continue the boot up sequence with non-fatal errors.

### System configuration verification

These routines check the current system configuration stored in the CMOS memory and BIOS NVRAM. If system configuration is not found or system configuration data error is detected, system will load optimized default and re-boot with this default system configuration automatically.

There are four situations in which you will need to setup system configuration:

1. You are starting your system for the first time
2. You have changed the hardware attached to your system
3. The system configuration is reset by Clear-CMOS jumper
4. The CMOS memory has lost power and the configuration information has been erased.

The GENE-TWL5 CMOS memory has an integral lithium battery backup for data retention. However, you will need to replace the battery unit when it finally runs down.

## 3.2 AMI BIOS Setup

---

AMI BIOS ROM has a built-in Setup program that allows users to modify the basic system configuration. This type of information is stored in battery-backed CMOS RAM and BIOS NVRAM so that it retains the Setup information when the power is turned off.

### Entering Setup

Power on the computer and press <Del> or <ESC> immediately. This will allow you to enter Setup.

### Main

Set the date, use tab to switch between date elements.

### Advanced

Enable/disable boot option for legacy network devices.

### Chipset

Host bridge parameters.

### Boot

Enables/disables quiet boot option.

### Security

Set setup administrator password.

### Save & Exit

Exit system setup after saving the changes.

### 3.3 Setup Submenu: Main

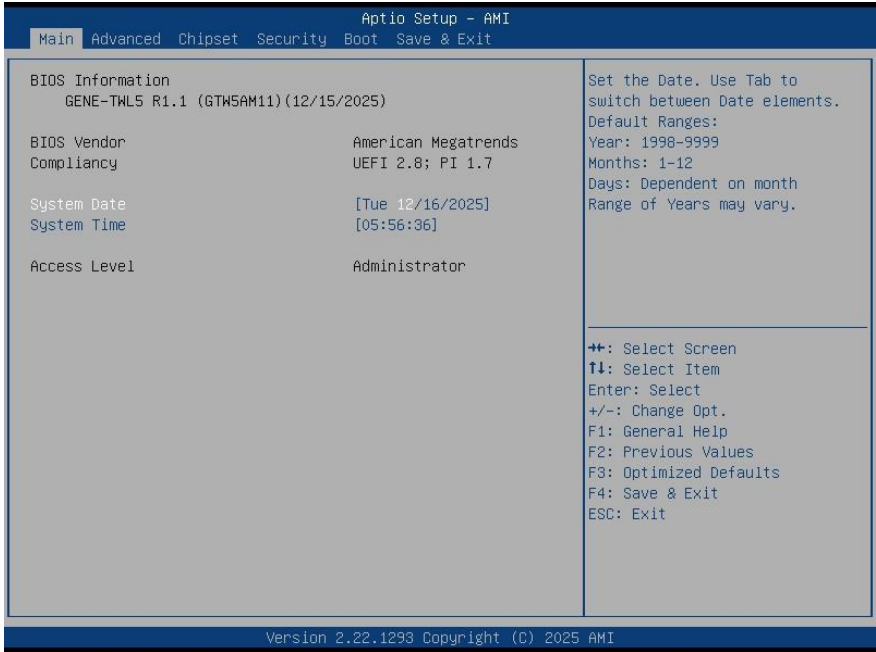

### 3.4 Setup Submenu: Advanced

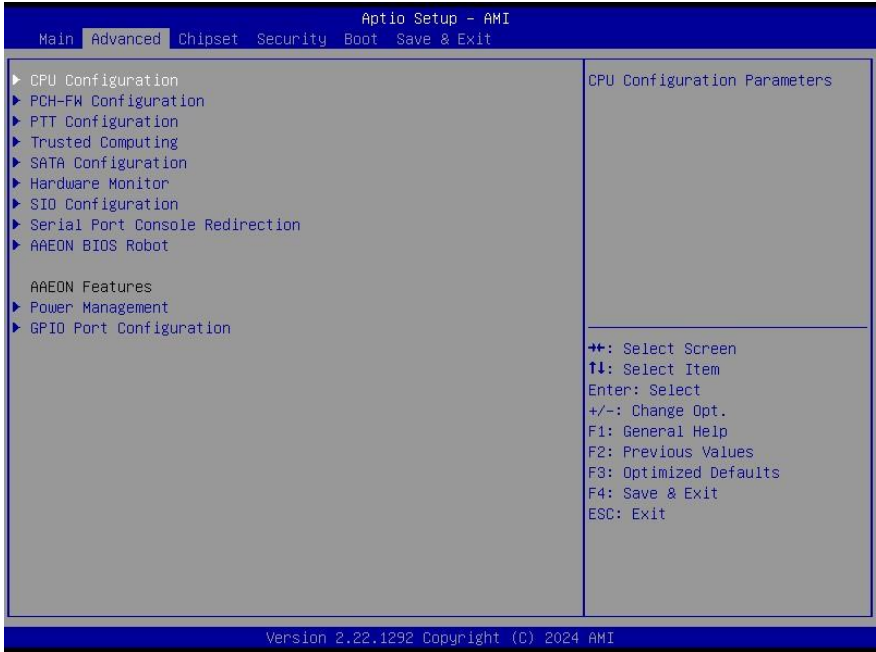

### 3.4.1 CPU Configuration

Aptio Setup - AMI

Advanced

|                                       |                          |   |
|---------------------------------------|--------------------------|---|
| CPU Configuration                     |                          | When enabled, a VMM can utilize the additional hardware capabilities provided by Vanderpool Technology.<br><br>⇧⇩: Select Screen<br>⇧⇩: Select Item<br>Enter: Select<br>+/-: Change Opt.<br>F1: General Help<br>F2: Previous Values<br>F8: Optimized Defaults<br>F4: Save & Exit<br>ESC: Exit |
| Type                                  | Intel(R) Core(TM) 3 N355 |   |
| ID                                    | 0xB06E0                  |   |
| Microcode Revision                    | 1D                       |   |
| Speed                                 | 1900 MHz                 |   |
| VMX                                   | Supported                |   |
| SMX/TXT                               | Supported                |   |
| L1 Data Cache                         | 32 KB x 8                |   |
| L1 Instruction Cache                  | 64 KB x 8                |   |
| L2 Cache                              | 2048 KB x 2              |   |
| L3 Cache                              | 6 MB                     |   |
| Intel (VMX) Virtualization Technology | [Enabled]                |   |
| Intel(R) SpeedStep(tm)                | [Enabled]                |   |
| Turbo Mode                            | [Enabled]                |   |
| C states                              | [Enabled]                |   |

Version 2.22.1293 Copyright (C) 2025 AMI

| Options Summary   |          |                                   |
|---|----------|-----------------------------------|
| <b>Intel (VMX) Virtualization Technology</b>  | Disabled |                                   |
|   | Enabled  | Optimal Default, Failsafe Default |
| When enabled, a VMM can utilize the additional hardware capabilities provided by Vanderpool Technology.               |          |                                   |
| <b>Intel® SpeedStep™</b>  | Disabled |                                   |
|   | Enabled  | Optimal Default, Failsafe Default |
| Allows more than two frequency ranges to be supported.  |          |                                   |
| <b>Turbo Mode</b>   | Disabled |                                   |
|   | Enabled  | Optimal Default, Failsafe Default |
| Enable or disable the processor's Turbo Mode (requires EMTTM to be enabled). <b>AUTO</b> means Turbo Mode is enabled. |          |                                   |
| <b>C states</b>   | Disabled |                                   |
|   | Enabled  | Optimal Default, Failsafe Default |
| Enable/Disable CPU Power Management. Allows CPU to go to C states when it's not 100 utilized.                         |          |                                   |

### 3.4.2 PCH-FW Configuration

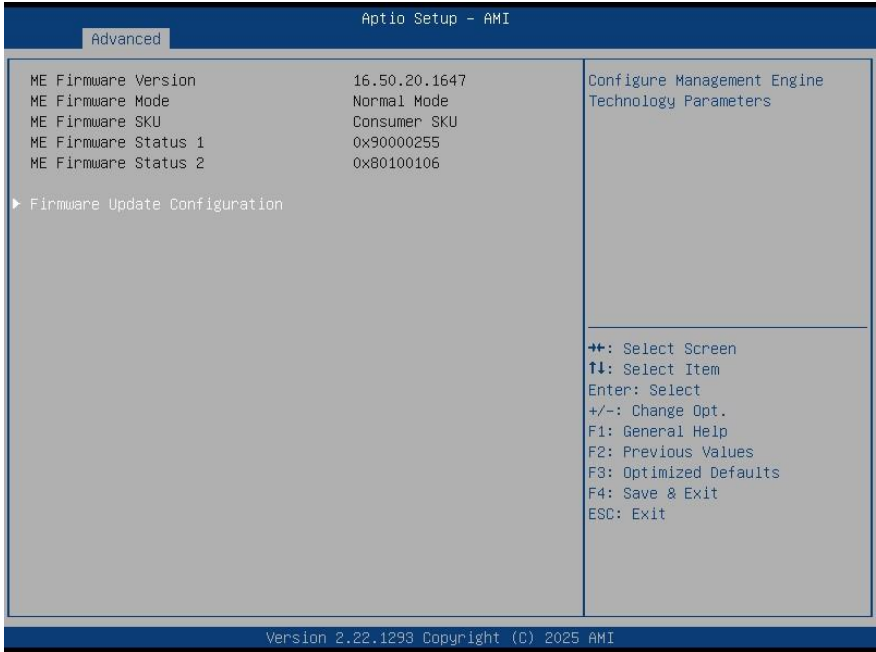

### 3.4.3 Firmware Update Configuration

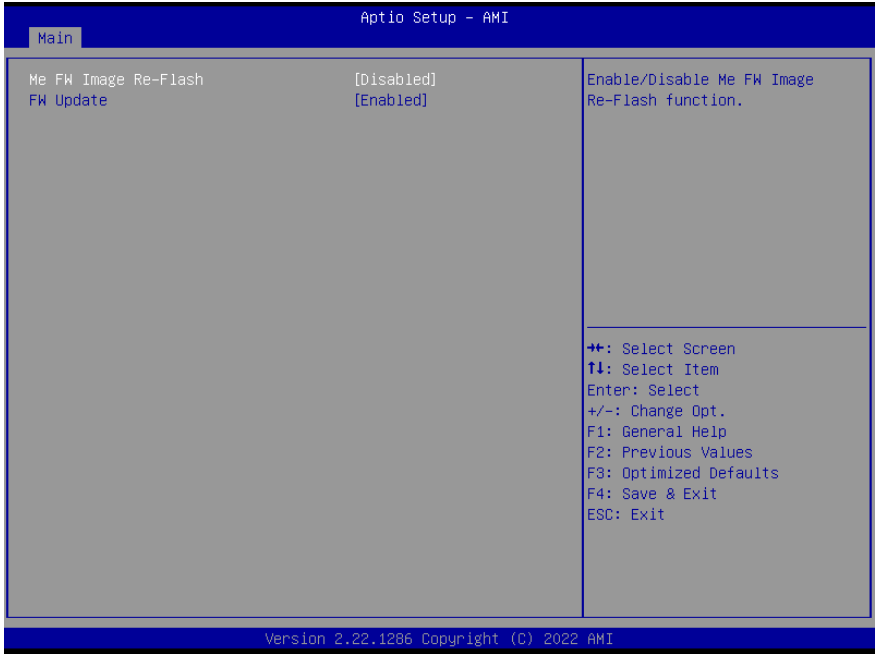

| Options Summary                               |          |                                   |
|---|----------|-----------------------------------|
| Me FW Image Re-Flash                          | Enabled  |                                   |
|   | Disabled | Optimal Default, Failsafe Default |
| Enable/Disable Me FW Image Re-Flash function. |          |                                   |
| FW Update                                     | Disabled |                                   |
|   | Enabled  | Optimal Default, Failsafe Default |
| Enable/Disable ME FW Update function.         |          |                                   |

### 3.4.4 PTT Configuration

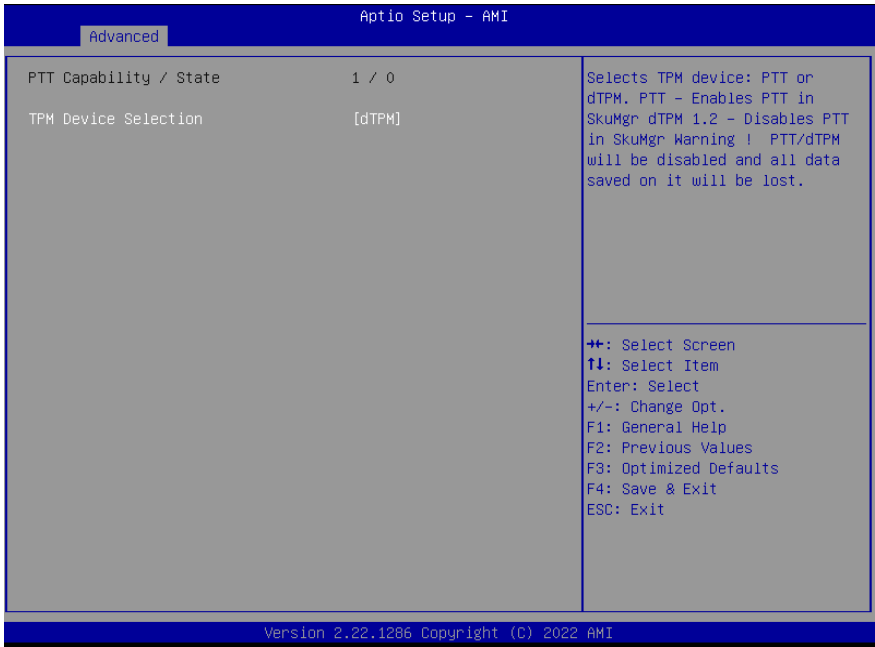

| Options Summary  |      |                                   |
|--|------|-----------------------------------|
| TPM Device Selection   | dTPM | Optimal Default, Failsafe Default |
|  | PTT  |                                   |
| <p>Select the TPM device: PTT or discrete TPM.<br/>                     PTT – Enables PTT in SkuMgr.<br/>                     dTPM – Disables PTT in SkuMgr.<br/> <b>Warning:</b> Switching between PTT and dTPM will disable the current TPM and erase all data stored on it.</p> |      |                                   |

### 3.4.5 Trusted Computing

Aptio Setup - AMI

Advanced

|  |  |
|--|--|
| <p>TPM 2.0 Device Found<br/>Firmware Version: 7.2<br/>Vendor: NTC</p> <p>Security Device Support [Enabled]<br/>Active PCR banks SHA256<br/>Available PCR banks SHA256,SHA384</p> <p>SHA256 PCR Bank [Enabled]<br/>SHA384 PCR Bank [Disabled]</p> <p>Pending operation [None]<br/>Platform Hierarchy [Enabled]<br/>Storage Hierarchy [Enabled]<br/>Endorsement Hierarchy [Enabled]<br/>Physical Presence Spec Version [1.3]<br/>TPM 2.0 InterfaceType [TIS]<br/>Device Select [TPM 2.0]</p> | <p>Enables or Disables BIOS support for security device. O.S. will not show Security Device. TCG EFI protocol and INT1A interface will not be available.</p> <hr/> <p>++: Select Screen<br/>T1: Select Item<br/>Enter: Select<br/>+/-: Change Opt.<br/>F1: General Help<br/>F2: Previous Values<br/>F3: Optimized Defaults<br/>F4: Save &amp; Exit<br/>ESC: Exit</p> |
|--|--|

Version 2.22.1286 Copyright (C) 2022 AMI

| Options Summary  |           |                                   |
|--|-----------|-----------------------------------|
| <b>Security Device Support</b>   | Enable    | Optimal Default, Failsafe Default |
|  | Disable   |                                   |
| Enable or disable BIOS support for the security device. When disabled, the operating system will not detect the security device, and the TCG EFI protocol and INT1A interface will be unavailable. |           |                                   |
| <b>SHA256 PCR Bank</b>   | Enabled   | Optimal Default, Failsafe Default |
|  | Disabled  |                                   |
| Enable or Disable SHA256 PCR Bank.   |           |                                   |
| <b>SHA384 PCR Bank</b>   | Enabled   | Optimal Default, Failsafe Default |
|  | Disabled  |                                   |
| Enable or Disable SHA384 PCR Bank.   |           |                                   |
| <b>Pending operation</b>   | None      | Optimal Default, Failsafe Default |
|  | TPM Clear |                                   |
| Schedule an operation for the security device.   |           |                                   |
| <b>Note:</b> The computer will restart automatically to apply the security device state change.  |           |                                   |

| Options Summary  |          |                                   |
|--|----------|-----------------------------------|
| Platform Hierarchy   | Enabled  | Optimal Default, Failsafe Default |
|  | Disabled |                                   |
| Enable or Disable Platform Hierarchy   |          |                                   |
| Storage Hierarchy  | Enabled  | Optimal Default, Failsafe Default |
|  | Disabled |                                   |
| Enable or Disable Storage Hierarchy  |          |                                   |
| Endorsement Hierarchy  | Enabled  | Optimal Default, Failsafe Default |
|  | Disabled |                                   |
| Enable or Disable Endorsement Hierarchy  |          |                                   |
| Physical Presence Spec Version   | 1.3      | Optimal Default, Failsafe Default |
|  | 1.2      |                                   |
| Select whether to inform the operating system to support PPI Specification version 1.2 or 1.3.<br><b>Note:</b> Some HCK tests may not be compatible with version 1.3.  |          |                                   |
| Device Select  | Auto     |                                   |
|  | TPM 1.2  |                                   |
|  | TPM 2.0  | Optimal Default, Failsafe Default |
| <p><b>TPM 1.2</b> – Supports only TPM 1.2 devices.</p> <p><b>TPM 2.0</b> – Supports only TPM 2.0 devices.</p> <p><b>Auto</b> – Supports both TPM 1.2 and TPM 2.0 devices. If no TPM is detected, the system defaults to TPM 2.0.</p> <p>TPM 1.2 devices will still be enumerated when present.</p> |          |                                   |

### 3.4.6 SATA Configuration

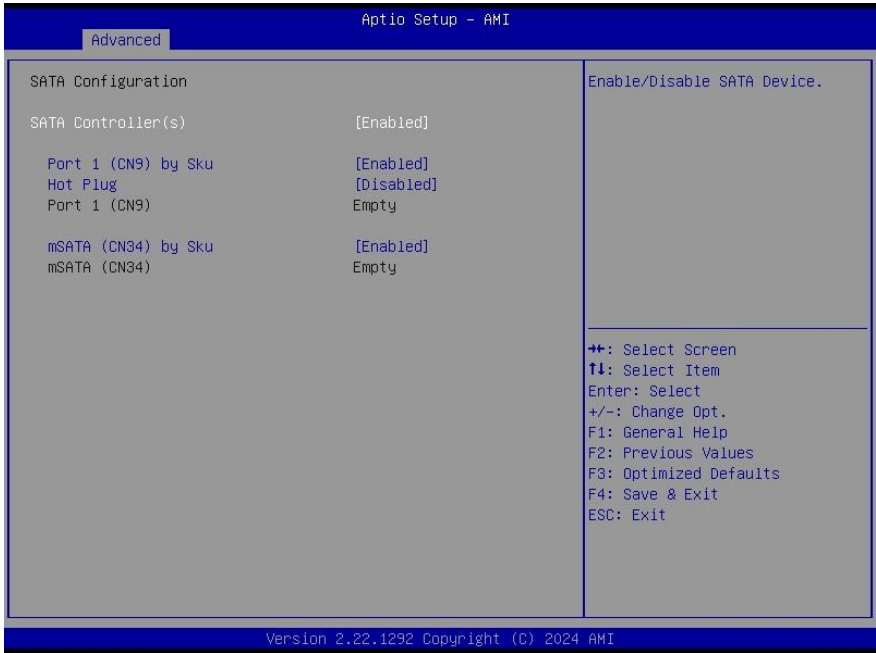

| Options Summary              |          |                                   |
|------------------------------|----------|-----------------------------------|
| SATA Controller(s)           | Enabled  | Optimal Default, Failsafe Default |
|                              | Disabled |                                   |
| Enable/Disable SATA Device.  |          |                                   |
| Port 1(CN9)                  | Enabled  | Optimal Default, Failsafe Default |
|                              | Disabled |                                   |
| Enable or Disable SATA Port. |          |                                   |
| mSATA (CN34)                 | Enabled  | Optimal Default, Failsafe Default |
|                              | Disabled |                                   |
| Enable or Disable SATA Port. |          |                                   |

### 3.4.7 Hardware Monitor

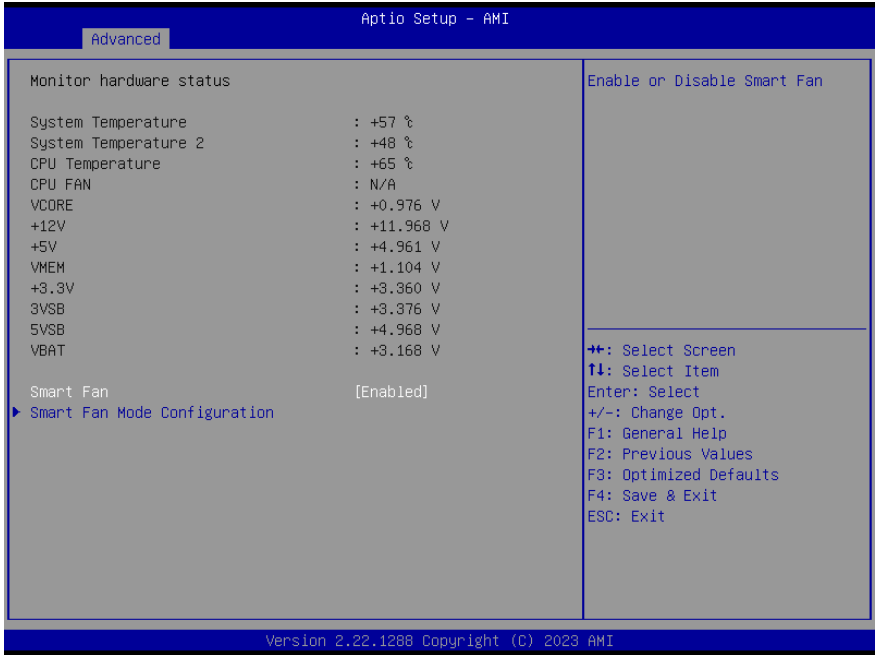

| Options Summary                |          |                                   |
|--------------------------------|----------|-----------------------------------|
| Smart Fan                      | Disabled |                                   |
|                                | Enabled  | Optimal Default, Failsafe Default |
| Enables or Disables Smart Fan. |          |                                   |

### 3.4.7.1 Smart Fan Mode Configuration

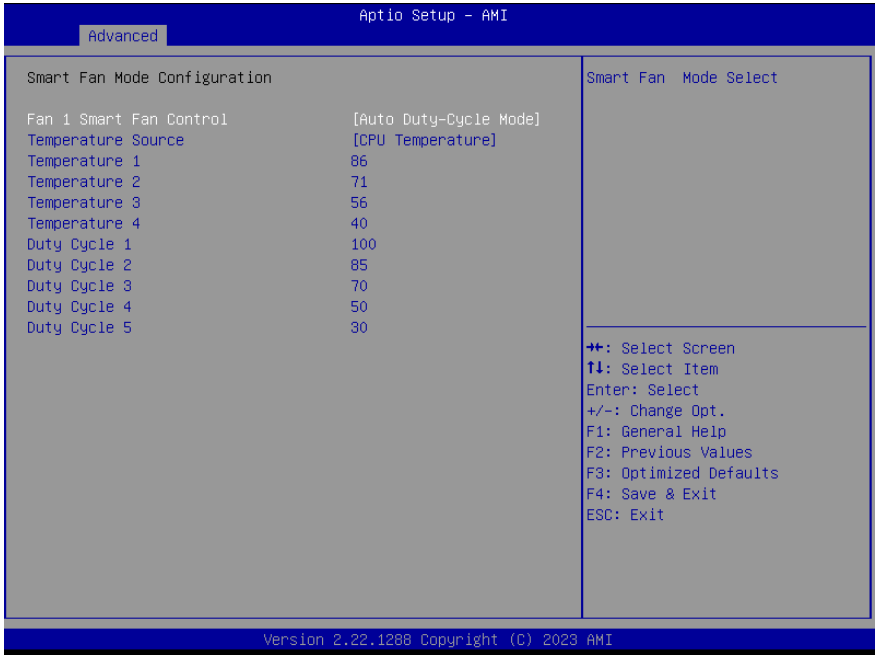

| Options Summary   |                      |                                   |
|---|----------------------|-----------------------------------|
| Fan 1 Smart Fan Control   | Manual Duty Mode     |                                   |
|   | Auto Duty-Cycle Mode | Optimal Default, Failsafe Default |
| Smart Fan Mode Select.  |                      |                                   |
| Temperature Source  | CPU Temperature      | Optimal Default, Failsafe Default |
|   | System Temperature   |                                   |
|   | System Temperature 2 |                                   |
| Select the monitored temperature source for this fan.   |                      |                                   |
| Temperature 1   | 86                   |                                   |
| Duty Cycle 1  | 100                  |                                   |
| Automatic fan speed control. The fan speed adjusts according to temperature, using different duty cycles ranging from 1% to 100%. |                      |                                   |

### 3.4.8 SIO Configuration



### 3.4.8.1 Serial Port 1 Configuration

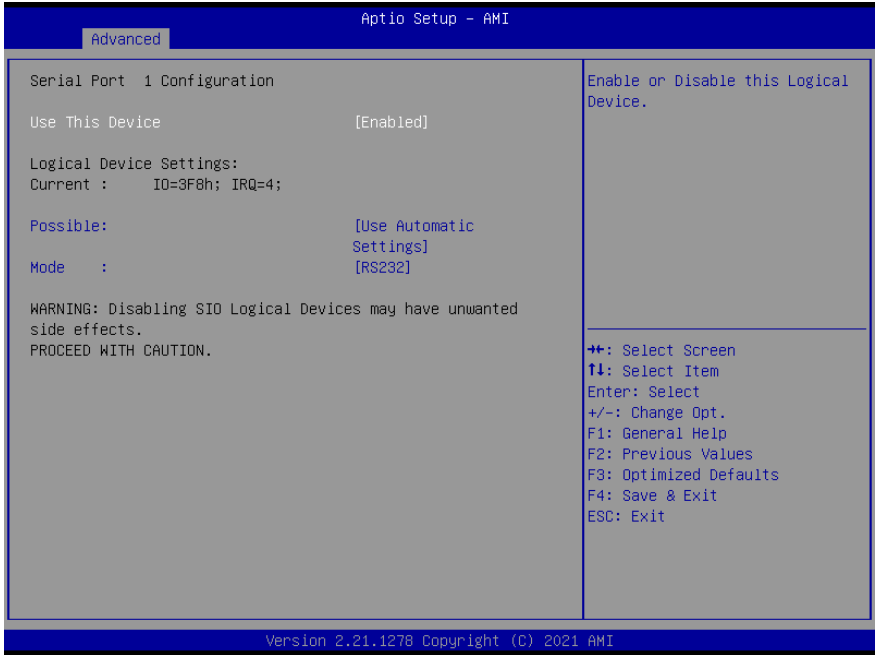

| Options Summary  |                        |                                   |
|--|------------------------|-----------------------------------|
| Use This Device  | Disable                |                                   |
|  | Enable                 | Optimal Default, Failsafe Default |
| Enable or Disable this Logical Device.   |                        |                                   |
| Possible:  | Use Automatic Settings | Optimal Default, Failsafe Default |
|  | IO=3F8h; IRQ=4         |                                   |
|  | IO=2F8h; IRQ=3         |                                   |
| Allows user to change Device's Resource settings. New settings will be reflected on This Setup Page after System restarts. |                        |                                   |
| Mode:  | RS232                  | Optimal Default, Failsafe Default |
|  | RS422                  |                                   |
|  | RS485                  |                                   |
| UART RS232, 422, 485 selection.  |                        |                                   |

### 3.4.8.2 Serial Port 2 Configuration

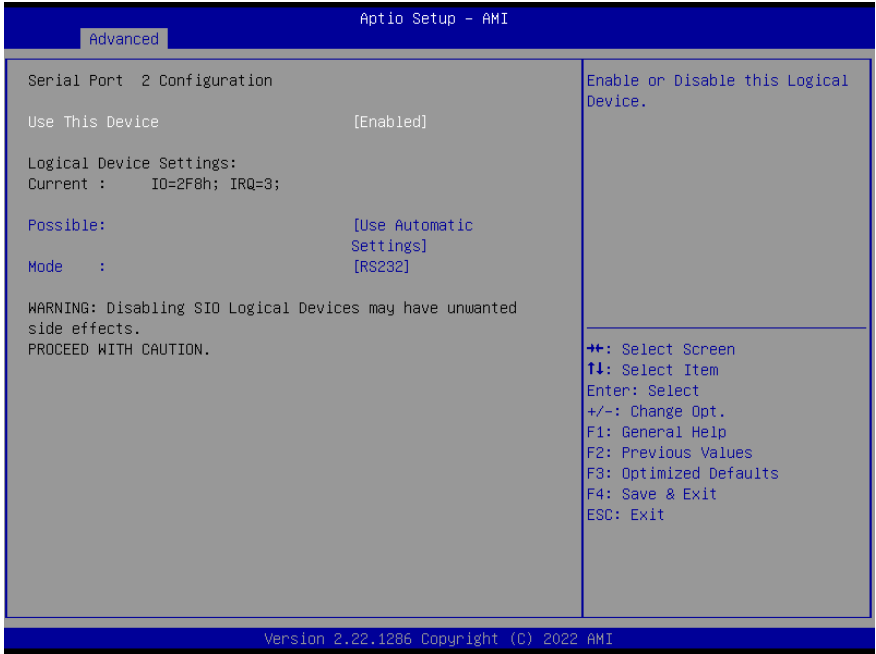

| Options Summary  |                        |                                   |
|--|------------------------|-----------------------------------|
| Use This Device  | Disable                |                                   |
|  | Enable                 | Optimal Default, Failsafe Default |
| Enable or Disable this Logical Device.   |                        |                                   |
| Possible:  | Use Automatic Settings | Optimal Default, Failsafe Default |
|  | IO=2F8h; IRQ=3         |                                   |
|  | IO=3F8h; IRQ=4         |                                   |
| Allows user to change Device's Resource settings. New settings will be reflected on This Setup Page after System restarts. |                        |                                   |
| Mode:  | RS232                  | Optimal Default, Failsafe Default |
|  | RS422                  |                                   |
|  | RS485                  |                                   |
| UART RS232, 422, 485 selection.  |                        |                                   |

### 3.4.8.3 Serial Port 3 Configuration

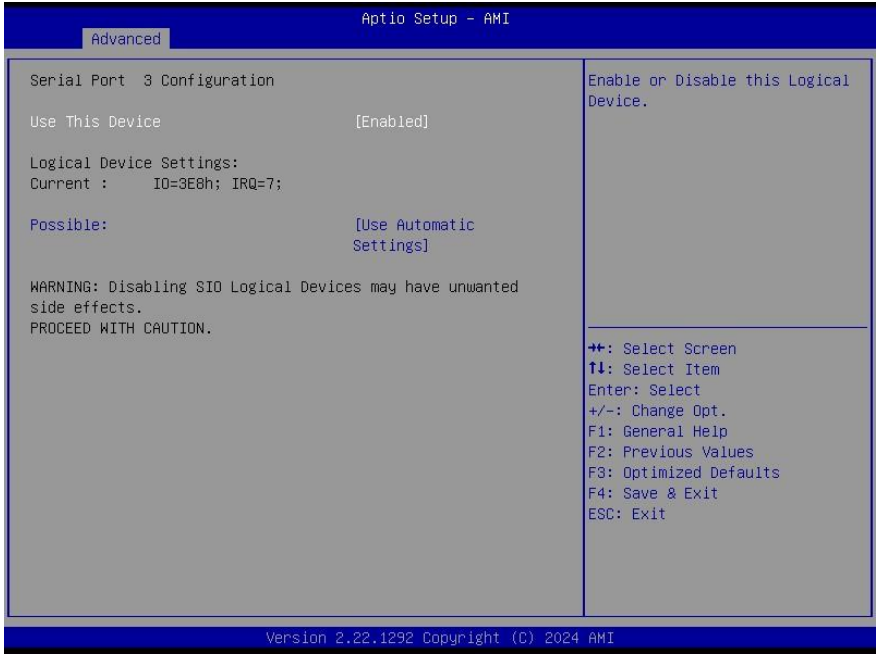

| Options Summary  |                        |                                   |
|--|------------------------|-----------------------------------|
| Use This Device  | Disable                |                                   |
|  | Enable                 | Optimal Default, Failsafe Default |
| Enable or Disable this Logical Device.   |                        |                                   |
| Possible:  | Use Automatic Settings | Optimal Default, Failsafe Default |
|  | IO=3E8h; IRQ=7         |                                   |
|  | IO=2E8h; IRQ=8         |                                   |
| Allows user to change Device's Resource settings. New settings will be reflected on This Setup Page after System restarts. |                        |                                   |

### 3.4.8.4 Serial Port 4 Configuration



| Options Summary  |                        |                                   |
|--|------------------------|-----------------------------------|
| Use This Device  | Disable                |                                   |
|  | Enable                 | Optimal Default, Failsafe Default |
| Enable or Disable this Logical Device.   |                        |                                   |
| Possible:  | Use Automatic Settings | Optimal Default, Failsafe Default |
|  | IO=2E8h; IRQ=6         |                                   |
|  | IO=3E8h; IRQ=7         |                                   |
| Allows user to change Device's Resource settings. New settings will be reflected on This Setup Page after System restarts. |                        |                                   |

### 3.4.9 Serial Port Console Redirection

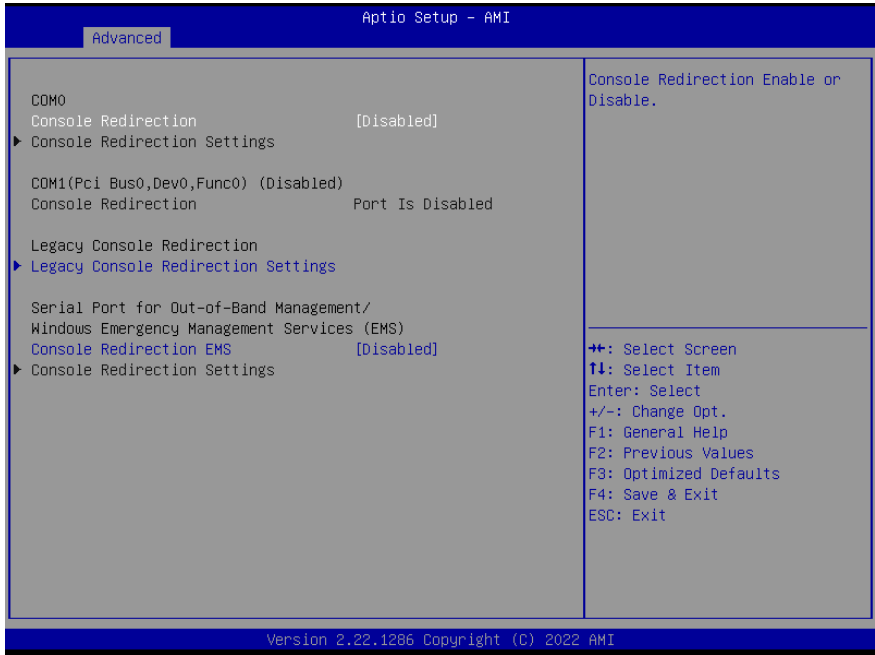

| Options Summary                        |          |                                   |
|--|----------|-----------------------------------|
| Console Redirection                    | Disabled | Optimal Default, Failsafe Default |
|  | Enabled  |                                   |
| Enable or Disable Console Redirection. |          |                                   |
| Console Redirection EMS                | Disabled | Optimal Default, Failsafe Default |
|  | Enabled  |                                   |
| Enable or Disable Console Redirection. |          |                                   |

### 3.4.10 Legacy Console Redirection Settings



| Options Summary  |  |                                   |
|--|--|-----------------------------------|
| Redirection COM port   | COM0                                   | Optimal Default, Failsafe Default |
|  | COM1(Pci Bus0, Dev0, Func0) (Disabled) |                                   |
| Select the COM port used to display redirection output for legacy operating systems and legacy Option ROM messages.  |  |                                   |
| Resolution   | 80x24                                  | Optimal Default, Failsafe Default |
|  | 80x25                                  |                                   |
| Specifies the number of rows and columns supported for redirection in a legacy operating system.   |  |                                   |
| Redirect After POST  | Always Enable                          | Optimal Default, Failsafe Default |
|  | BootLoader                             |                                   |
| When <b>Bootloader</b> is selected, Legacy Console Redirection is disabled before booting into a legacy operating system.  |  |                                   |
| When <b>Always Enable</b> is selected, Legacy Console Redirection remains enabled for the legacy OS. The default setting for this option is <b>Always Enable</b> . |  |                                   |

### 3.4.11 AAEON BIOS Robot



| Options Summary   |          |                                   |
|---|----------|-----------------------------------|
| Sends watch dog before BIOS POST  | Disabled | Optimal Default, Failsafe Default |
|   | Enabled  |                                   |
| <p><b>Enabled</b> – The robot sets the Watch Dog Timer (WDT) immediately after power-on, before the BIOS starts the POST process. The robot then clears the WDT upon completion of POST. If the WDT is not cleared before the timer expires, it will automatically reset the system.</p>            |          |                                   |
| POST Timer (second)   | 30       | Optimal Default, Failsafe Default |
| <p>Sets the Watch Dog Timer (WDT) duration for POST.</p> <p><b>Warning:</b> Do not set this value equal to or shorter than the normal POST time, as the system may fail to complete POST unless BIOS settings are cleared. It is recommended to set it to more than twice the normal POST time.</p> |          |                                   |
| Sends watch dog before booting OS   | Disabled | Optimal Default, Failsafe Default |
|   | Enabled  |                                   |
| <p><b>Enabled</b> – The robot sets the Watch Dog Timer (WDT) after POST completes, but before the BIOS transfers control to the operating system.</p>   |          |                                   |

| Options Summary   |             |                                   |
|---|-------------|-----------------------------------|
| <b>Warning:</b> Before enabling this function, an OS program must be responsible for clearing the WDT. This function should be disabled if the operating system will perform updates.   |             |                                   |
| <b>OS Timer (minute)</b>  | 3           | Optimal Default, Failsafe Default |
| Sets the Watch Dog Timer (WDT) duration for operating system loading.   |             |                                   |
| <b>Delayed POST (PEI phase)</b>   | Disabled    | Optimal Default, Failsafe Default |
|   | Enabled     |                                   |
| <b>Enabled</b> – The robot delays the BIOS from starting POST immediately after power-on. This allows the POST process to begin with stable power or after the system has physically warmed up.<br><b>Note:</b> This action occurs before the "Send Watch Dog" operation. |             |                                   |
| <b>Delayed time (second)</b>  | 10          | Optimal Default, Failsafe Default |
| Period of time for Robot to hold BIOS from POST.  |             |                                   |
| <b>Delayed POST (DXE phase)</b>   | Disabled    | Optimal Default, Failsafe Default |
|   | Enabled     |                                   |
| <b>Enabled</b> – The robot delays the BIOS before POST completion. This ensures the POST process runs with stable power or after the system has physically warmed up.<br><b>Note:</b> This action occurs after "Send Watch Dog before BIOS POST."                         |             |                                   |
| <b>Delayed time (second)</b>  | 10          | Optimal Default, Failsafe Default |
| Period of time for Robot to hold BIOS from POST.  |             |                                   |
| <b>Reset system once</b>  | Disabled    | Optimal Default, Failsafe Default |
|   | Enabled     |                                   |
| <b>Enabled</b> – The robot performs a one-time system reset on each boot. This sends either a soft or hard reset to onboard devices, helping them reach a more stable state.  |             |                                   |
| <b>Soft or hard reset</b>   | Soft reset  | Optimal Default, Failsafe Default |
|   | Hard reset" |                                   |
| Select reset type robot should send on each boot.   |             |                                   |

### 3.4.12 Power Management



| Options Summary  |            |                                   |
|--|------------|-----------------------------------|
| Power Mode   | ATX Type   | Optimal Default, Failsafe Default |
|  | AT Type    |                                   |
| Select power supply mode.  |            |                                   |
| Power Saving (ERP) Control   | Disabled   | Optimal Default, Failsafe Default |
|  | Enabled    |                                   |
| Configure power mode for power saving function   |            |                                   |
| Restore AC Power Loss  | Last State | Optimal Default, Failsafe Default |
|  | Always On  |                                   |
|  | Always Off |                                   |
| Select the power state the system will enter when power is restored after a power failure. |            |                                   |
| Soft-Off (S5) Wake On RTC  | Disable    | Optimal Default, Failsafe Default |
|  | By Date    |                                   |
|  | By Weekday |                                   |
|  | Bypass     |                                   |

**Options Summary**

**By Date:** The system will wake at the specified hour, minute, and second on the selected date.  
**By Weekday:** The system will wake at the specified hour, minute, and second on the selected weekdays.  
**Bypass:** The BIOS will not control the RTC wake function.

**3.4.13 GPIO Port Configuration**

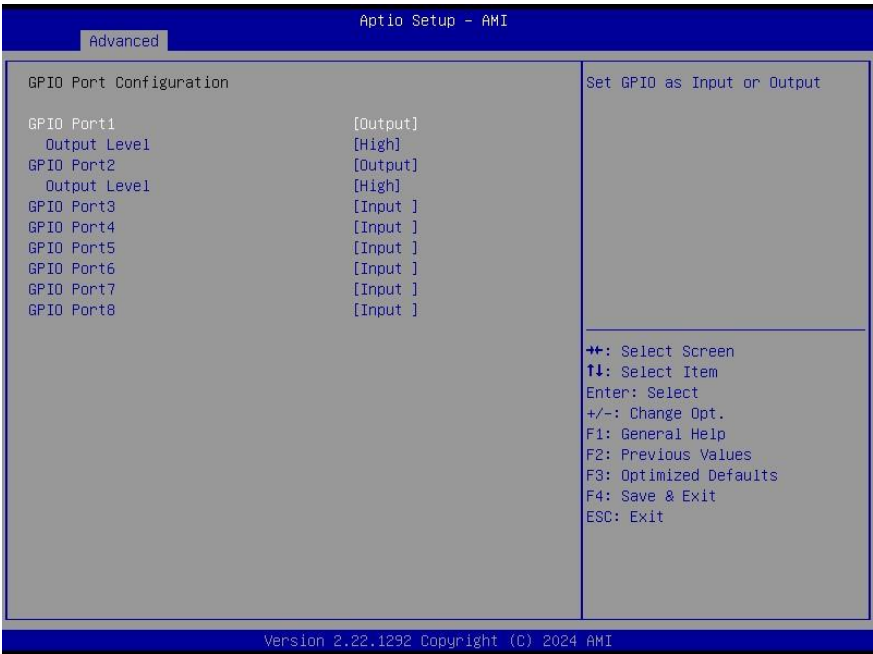

**Options Summary**

|   |        |  |
|---|--------|--|
| GPIO Port*                                | Output |  |
|   | Input  |  |
| Set GPIO as Input or Output.              |        |  |
| Output Level                              | High   |  |
|   | Low    |  |
| Set output level when GPIO pin is Output. |        |  |

### 3.5 Setup Submenu: Chipset



### 3.5.1 System Agent (SA) Configuration



| Options Summary  |          |                                   |
|------------------|----------|-----------------------------------|
| VT-d             | Disabled | Optimal Default, Failsafe Default |
|                  | Enabled  |                                   |
| VT-d capability. |          |                                   |

## 3.5.2 Memory Configuration

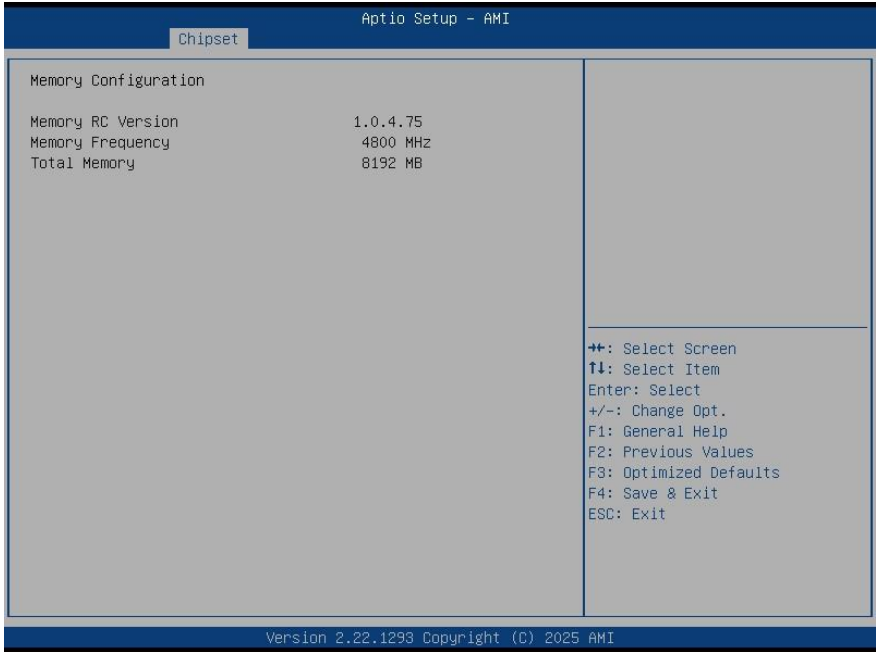

### 3.5.3 LVDS Panel Configuration



| Options Summary            |                |         |
|----------------------------|----------------|---------|
| LVDS                       | 640x480@60Hz   |         |
|                            | 800x480@60Hz   |         |
|                            | 800x600@60Hz   |         |
|                            | 1024x600@60Hz  |         |
|                            | 1024x768@60Hz  | Default |
|                            | 1280x768@60Hz  |         |
|                            | 1280x800@60Hz  |         |
|                            | 1280x1024@60Hz |         |
|                            | 1366x768@60Hz  |         |
|                            | 1440x900@60Hz  |         |
|                            | 1600x1200@60Hz |         |
|                            | 1920x1080@60Hz |         |
|                            | 1920x1200@60Hz |         |
| Enable/Disable this panel. |                |         |

| Options Summary                       |                    |                                   |
|---------------------------------------|--------------------|-----------------------------------|
| Panel Type                            | 18-Bit             | Optimal Default, Failsafe Default |
|                                       | 24-Bit             |                                   |
|                                       | 36-Bit             |                                   |
|                                       | 48-Bit             |                                   |
| Select panel type.                    |                    |                                   |
| Backlight Mode                        | BIOS & Application | Default                           |
|                                       | Windows Slider     |                                   |
| Select backlight control signal type. |                    |                                   |

### 3.5.4 PCH-IO Configuration

Aptio Setup - AMI

Chipset

|                                   |              |  |
|-----------------------------------|--------------|--|
| HD Audio                          | [Enabled]    | Select function enabled for USB(CN37) slot |
| Full-MiniCard Slot Function(CN34) | [PCIe]       |  |
| USB Slot Function(CN37)           | [USB PCIeX1] |  |

++: Select Screen  
 F1: Select Item  
 Enter: Select  
 +/-: Change Opt.  
 F1: General Help  
 F2: Previous Values  
 F8: Optimized Defaults  
 F4: Save & Exit  
 ESC: Exit

Version 2.22.1292 Copyright (C) 2024 AMI

| Options Summary                              |          |                                   |
|--|----------|-----------------------------------|
| HD Audio                                     | Disabled |                                   |
|  | Enabled  | Optimal Default, Failsafe Default |
| Controls detection of the HD-Audio device.   |          |                                   |
| Disable – HD-Audio (HAD) is always disabled. |          |                                   |

| Options Summary  |            |                                   |
|--|------------|-----------------------------------|
| Enable – HD-Audio (HAD) is always enabled.                       |            |                                   |
| Full-MiniCard Slot Function (CN34)                               | SATA       |                                   |
|  | PCIe       | Optimal Default, Failsafe Default |
| Select the function to enable for the Full-MiniCard (CN34) slot. |            |                                   |
| USB Slot Function(CN37)  | USB PCIeX1 | Optimal Default, Failsafe Default |
|  | PCIeX2     |                                   |
| Select the function to enable for the USB (CN37) slot.           |            |                                   |

## 3.6 Setup Submenu: Security

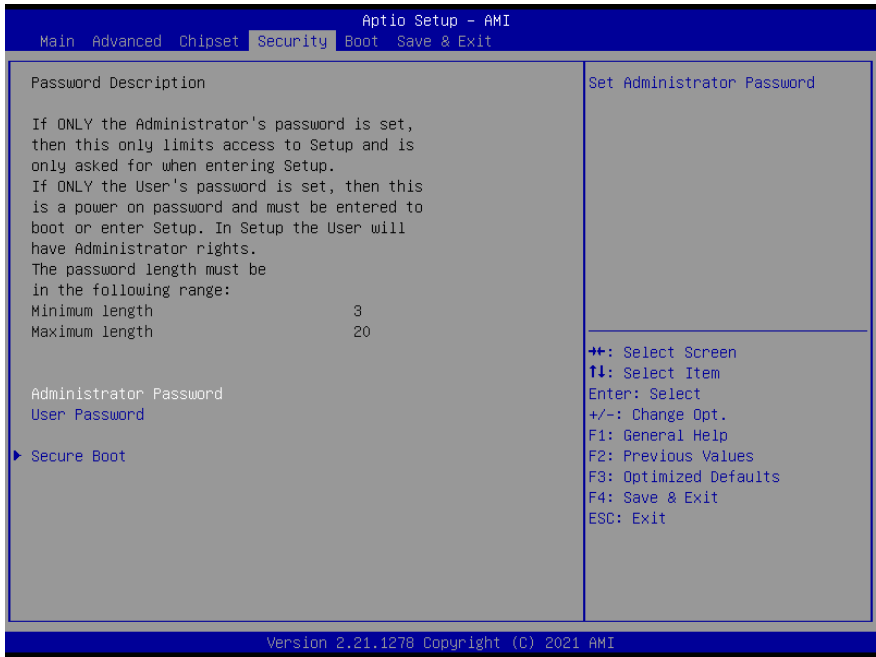

### Change User/Supervisor Password

You can install a Supervisor password, and if you install a supervisor password, you can then install a user password. A user password does not provide access to many of the features in the Setup utility.

If you highlight these items and press Enter, a dialog box appears which lets you enter a password. You can enter no more than six letters or numbers. Press Enter after you have typed in the password. A second dialog box asks you to retype the password for confirmation. Press Enter after you have retyped it correctly. The password is required at boot time, or when the user enters the Setup utility.

### Removing the Password

Highlight this item and type in the current password. At the next dialog box press Enter to disable password protection.

### 3.6.1 Secure Boot

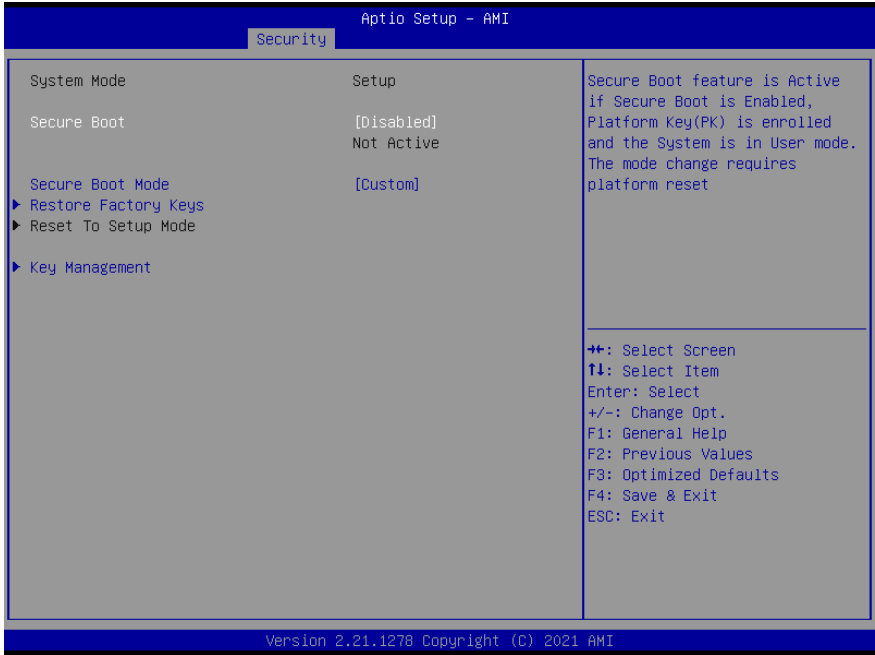

| Options Summary   |          |                                   |
|---|----------|-----------------------------------|
| Secure Boot   | Disabled | Optimal Default, Failsafe Default |
|   | Enabled  |                                   |
| The Secure Boot feature is <b>active</b> when Secure Boot is enabled, the Platform Key (PK) is enrolled, and the system is in <b>User mode</b> . Changing the mode requires a platform reset.   |          |                                   |
| Secure Boot Mode  | Custom   | Optimal Default, Failsafe Default |
|   | Standard |                                   |
| Secure Boot mode options: <b>Standard</b> or <b>Custom</b> .<br>In <b>Custom</b> mode, Secure Boot policy variables can be configured by a physically present user without full authentication. |          |                                   |
| <b>Restore Factory Keys</b>   |          |                                   |
| Force System to User Mode. Install factory default Secure Boot key databases.   |          |                                   |
| <b>Reset to Setup Mode</b>  |          |                                   |
| Delete all Secure Boot key databases from NVRAM.  |          |                                   |

## 3.6.2 Key Management

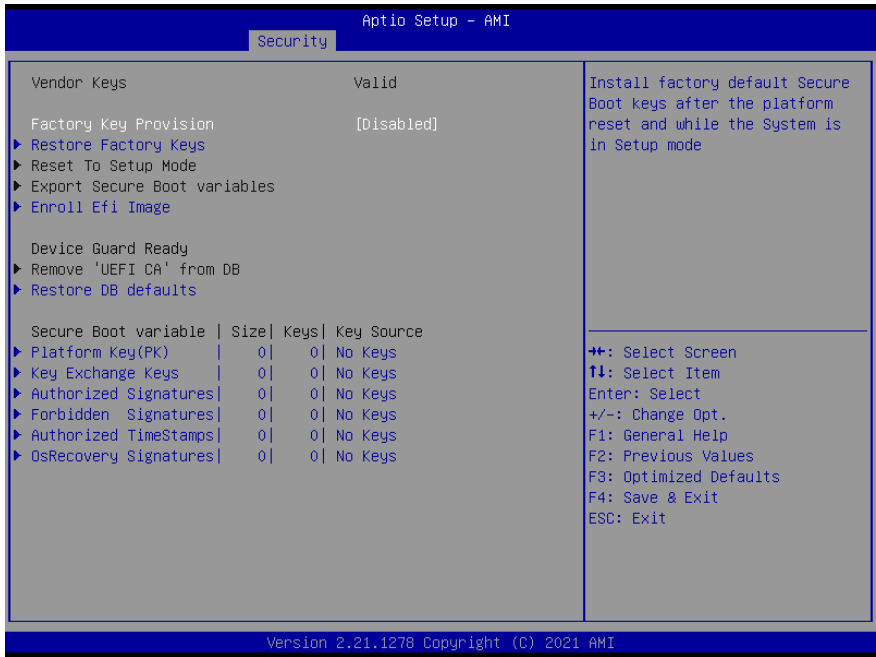

| Options Summary   |          |                                   |
|---|----------|-----------------------------------|
| Factory Key Provision   | Disabled | Optimal Default, Failsafe Default |
|   | Enabled  |                                   |
| <p>The Secure Boot feature is <b>active</b> when Secure Boot is enabled, the Platform Key (PK) is enrolled, and the system is in <b>User mode</b>.<br/>Changing the mode requires a platform reset.</p> |          |                                   |
| <b>Restore Factory Keys</b>   |          |                                   |
| Force System to User Mode. Install factory default Secure Boot key databases.   |          |                                   |
| <b>Reset to Setup Mode</b>  |          |                                   |
| Delete all Secure Boot key databases from NVRAM.  |          |                                   |
| <b>Export Secure Boot variables</b>   |          |                                   |
| Copy NVRAM content of Secure Boot variables to files in a root folder on a file system device   |          |                                   |
| <b>Enroll Efi Image</b>   |          |                                   |
| Allows the image to run in Secure Boot mode by enrolling the SHA256 hash of a PE image into the Authorized Signature Database (db).   |          |                                   |

| Options Summary  |         |
|--|---------|
| <b>Remove 'UEFI CA' from DB</b>  |         |
| A Device Guard–ready system must not include the <b>Microsoft UEFI CA</b> certificate in the Authorized Signature Database (db). |         |
| <b>Restore DB defaults</b>   |         |
| Restore DB variable to factory defaults.   |         |
| <b>Platform Key (PK)</b>   | Details |
|  | Export  |
|  | Update  |
|  | Delete  |
| <b>Key Exchange Keys</b>   | Details |
|  | Export  |
|  | Update  |
|  | Append  |
|  | Delete  |
| <b>Authorized Signatures</b>   | Details |
|  | Export  |
|  | Update  |
|  | Append  |
|  | Delete  |
| <b>Forbidden Signatures</b>  | Details |
|  | Export  |
|  | Update  |
|  | Append  |
|  | Delete  |
| <b>Authorized TimeStamps</b>   | Update  |
|  | Append  |
| <b>OsRecovery Signatures</b>   | Update  |
|  | Append  |
| Enroll Factory Defaults or load certificates from a file:  |         |
| 1.Public Key Certificate:  |         |
| a) EFI_SIGNATURE_LIST  |         |
| b) EFI_CERT_X509 (DER)   |         |
| c) EFI_CERT_RSA2048 (bin)  |         |
| d) EFI_CERT_SHAXXX   |         |
| 2.Authenticated UEFI Variable  |         |
| 3.EFI PE/COFF Image (SHA256)   |         |
| Key Source: Factory, External, Mixed   |         |

### 3.7 Setup Submenu: Boot

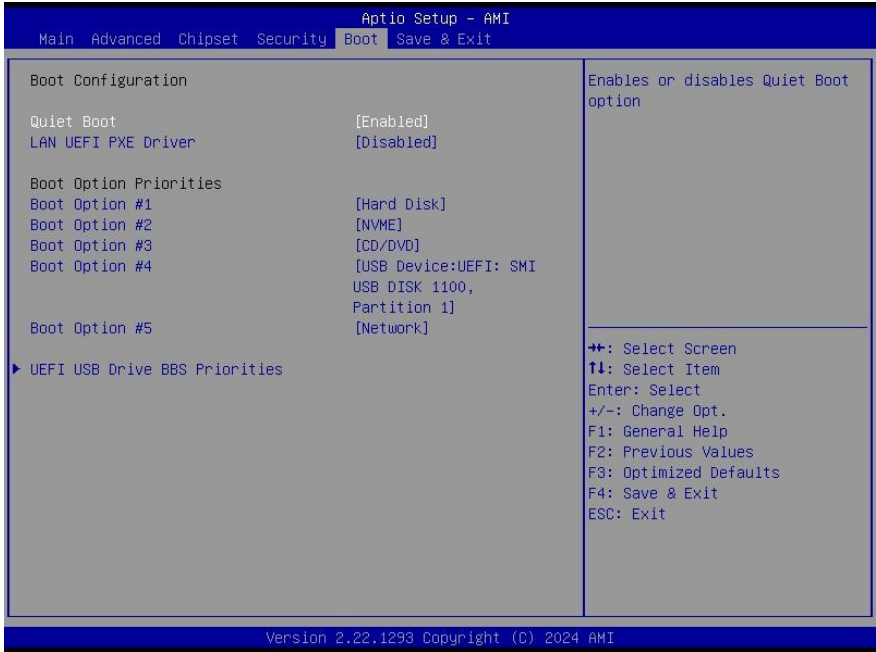

| Options Summary                      |          |                                   |
|--------------------------------------|----------|-----------------------------------|
| Quiet Boot                           | Disabled |                                   |
|                                      | Enabled  | Optimal Default, Failsafe Default |
| Enable or Disable Quiet Boot option. |          |                                   |
| UEFI PXE Support                     | Disabled | Optimal Default, Failsafe Default |
|                                      | Enabled  |                                   |
| Enable/Disable UEFI Network Stack.   |          |                                   |
| <b>FIXED BOOT ORDER Priorities</b>   |          |                                   |
| Sets the system boot order.          |          |                                   |

### 3.7.1 BBS Priorities



### 3.8 Setup Submenu: Save & Exit



| Options Summary          |  |
|--------------------------|--|
| Save Changes and Reset   | Reset the system after saving the changes.             |
| Discard Changes and Exit | Exit system setup without saving any changes.          |
| Restore Defaults         | Restore/Load Default values for all the setup options. |

# Chapter 4

---

Driver Installation

## 4.1 Driver Download/Installation

---

Drivers for the GENE-TWL5 can be downloaded from the product page on the AAEON website by following this link:

<https://www.aaeon.com/en/>

Download the driver(s) you need and follow the steps below to install them.

### Chipset Driver

1. Open the folder where you unzipped the **Chipset Drivers**.
2. Run the **SetupChipset.exe** file in the folder.
3. Follow the instructions.
4. Drivers will be installed automatically.

### Graphics Driver

1. Open the **Graphics Driver** folder
2. Run the **Installer.exe** file in the folder.
3. Follow the instructions.
4. Drivers will be installed automatically.
5. Refer to the ReadMe.txt for any assistance.

### LAN Driver

1. Open the folder where you unzipped the **LAN Drivers**.
2. Locate the **e2f.inf** file.
3. Right-click the **e2f.inf** file and select **Install**.
4. Follow any on-screen prompts.
5. The LAN driver will be installed automatically.

### Install PenMount Driver

1. Open the **PenMount Driver** folder
2. Open the **Setup.exe** file
3. Follow the instructions
4. Drivers will be installed automatically

### Install Intel ME & TXE Driver

1. Open the **Intel CSME** folder
2. Open the **SetupME.exe** file
3. Follow the instructions
4. Drivers will be installed automatically

### Install Peripheral Driver

1. Open the **Peripheral Driver** folder
2. Open the **SetupSerialIO.exe** file
3. Follow the instructions
4. Drivers will be installed automatically

### Install Intel Smart Sound Technology Driver

1. Open the **Intel Smart Sound Technology Driver** folder
2. Install Intel SST driver **IntcAudioBus.inf** and **IntcOED.inf**

| Name                         | Type                  | Compressed size | Password ... | Size     | Ratio |
|------------------------------|-----------------------|-----------------|--------------|----------|-------|
| WoV                          | File folder           |                 |              |          |       |
| detectionverificationdrv     | Security Catalog      | 10 KB           | No           | 43 KB    | 77%   |
| DetectionVerificationDrv     | Setup Information     | 4 KB            | No           | 21 KB    | 81%   |
| DetectionVerificationDrv.dll | Application extension | 375 KB          | No           | 824 KB   | 55%   |
| intcaudiobus                 | Security Catalog      | 12 KB           | No           | 41 KB    | 71%   |
| IntcAudioBus                 | Setup Information     | 6 KB            | No           | 35 KB    | 84%   |
| IntcAudioBus.sys             | System file           | 158 KB          | No           | 324 KB   | 52%   |
| intcbtau                     | Security Catalog      | 17 KB           | No           | 46 KB    | 63%   |
| IntcBTAu                     | Setup Information     | 8 KB            | No           | 121 KB   | 95%   |
| IntcBTAu.sys                 | System file           | 393 KB          | No           | 893 KB   | 57%   |
| intcbtle                     | Security Catalog      | 10 KB           | No           | 39 KB    | 75%   |
| IntcBtLE                     | Setup Information     | 3 KB            | No           | 15 KB    | 83%   |
| IntcBtLE.sys                 | System file           | 70 KB           | No           | 143 KB   | 51%   |
| intcdmic                     | Security Catalog      | 16 KB           | No           | 44 KB    | 65%   |
| IntcDMic                     | Setup Information     | 7 KB            | No           | 110 KB   | 94%   |
| IntcDMic.sys                 | System file           | 340 KB          | No           | 765 KB   | 56%   |
| intcoed                      | Security Catalog      | 33 KB           | No           | 140 KB   | 77%   |
| IntcOED                      | Setup Information     | 8 KB            | No           | 76 KB    | 90%   |
| IntcOED.sys                  | System file           | 592 KB          | No           | 1,253 KB | 53%   |

**Note:** Make sure to install **IntcAudioBus.inf** before installing **IntcOED.inf**. Right click on **IntcAudioBus.inf** and install **IntcOED.inf**, then **Install Driver**, as shown below:

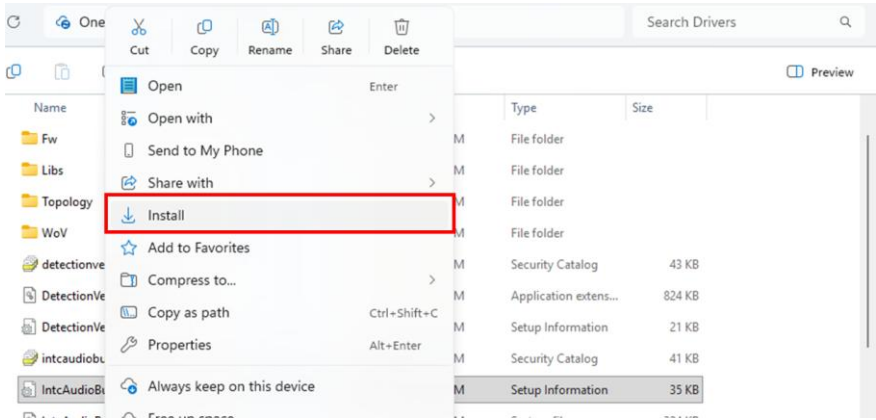

### Install Realtek Audio Driver

1. Open the **Windows Audio** folder followed by **Setup.exe**
2. Follow the instructions
3. Drivers will be installed automatically

### Install COM Port Driver

1. Open the **COM Port Driver** folder and select your OS
2. Open the **FintekSerial.exe** file
3. Follow the instructions
4. Drivers will be installed automatically





















































# Appendix A























































---

I/O Information



















































## A.1 I/O Address Map

|   |                                       |                                   |
|---|---------------------------------------|-----------------------------------|
| ▼ | Input/output (IO)                     |                                   |
| ▶ | [0000000000000000 - 000000000000CF7]  | PCI Express Root Complex          |
| ▶ | [0000000000000020 - 0000000000000021] | Programmable interrupt controller |
| ▶ | [0000000000000020 - 0000000000000021] | Programmable interrupt controller |
| ▶ | [0000000000000020 - 0000000000000021] | Programmable interrupt controller |
| ▶ | [0000000000000020 - 0000000000000021] | Programmable interrupt controller |
| ▶ | [0000000000000024 - 0000000000000025] | Programmable interrupt controller |
| ▶ | [0000000000000024 - 0000000000000025] | Programmable interrupt controller |
| ▶ | [0000000000000024 - 0000000000000025] | Programmable interrupt controller |
| ▶ | [0000000000000024 - 0000000000000025] | Programmable interrupt controller |
| ▶ | [0000000000000024 - 0000000000000025] | Programmable interrupt controller |
| ▶ | [0000000000000028 - 0000000000000029] | Programmable interrupt controller |
| ▶ | [0000000000000028 - 0000000000000029] | Programmable interrupt controller |
| ▶ | [0000000000000028 - 0000000000000029] | Programmable interrupt controller |
| ▶ | [0000000000000028 - 0000000000000029] | Programmable interrupt controller |
| ▶ | [000000000000002C - 000000000000002D] | Programmable interrupt controller |
| ▶ | [000000000000002C - 000000000000002D] | Programmable interrupt controller |
| ▶ | [000000000000002C - 000000000000002D] | Programmable interrupt controller |
| ▶ | [000000000000002C - 000000000000002D] | Programmable interrupt controller |
| ▶ | [000000000000002E - 000000000000002F] | Motherboard resources             |
| ▶ | [0000000000000030 - 0000000000000031] | Programmable interrupt controller |
| ▶ | [0000000000000030 - 0000000000000031] | Programmable interrupt controller |
| ▶ | [0000000000000030 - 0000000000000031] | Programmable interrupt controller |
| ▶ | [0000000000000030 - 0000000000000031] | Programmable interrupt controller |
| ▶ | [0000000000000034 - 0000000000000035] | Programmable interrupt controller |
| ▶ | [0000000000000034 - 0000000000000035] | Programmable interrupt controller |
| ▶ | [0000000000000034 - 0000000000000035] | Programmable interrupt controller |
| ▶ | [0000000000000034 - 0000000000000035] | Programmable interrupt controller |
| ▶ | [0000000000000038 - 0000000000000039] | Programmable interrupt controller |
| ▶ | [0000000000000038 - 0000000000000039] | Programmable interrupt controller |
| ▶ | [0000000000000038 - 0000000000000039] | Programmable interrupt controller |
| ▶ | [0000000000000038 - 0000000000000039] | Programmable interrupt controller |
| ▶ | [0000000000000038 - 0000000000000039] | Programmable interrupt controller |
| ▶ | [000000000000003C - 000000000000003D] | Programmable interrupt controller |
| ▶ | [000000000000003C - 000000000000003D] | Programmable interrupt controller |
| ▶ | [000000000000003C - 000000000000003D] | Programmable interrupt controller |
| ▶ | [000000000000003C - 000000000000003D] | Programmable interrupt controller |
| ▶ | [0000000000000040 - 0000000000000043] | System timer                      |
| ▶ | [0000000000000040 - 0000000000000043] | System timer                      |
| ▶ | [0000000000000040 - 0000000000000043] | System timer                      |
| ▶ | [0000000000000040 - 0000000000000043] | System timer                      |
| ▶ | [000000000000004E - 000000000000004F] | Motherboard resources             |
| ▶ | [0000000000000050 - 0000000000000053] | System timer                      |
| ▶ | [0000000000000050 - 0000000000000053] | System timer                      |
| ▶ | [0000000000000050 - 0000000000000053] | System timer                      |
| ▶ | [0000000000000050 - 0000000000000053] | System timer                      |
| ▶ | [0000000000000060 - 0000000000000060] | Standard PS/2 Keyboard            |
| ▶ | [0000000000000061 - 0000000000000061] | Motherboard resources             |
| ▶ | [0000000000000063 - 0000000000000063] | Motherboard resources             |
| ▶ | [0000000000000064 - 0000000000000064] | Standard PS/2 Keyboard            |
| ▶ | [0000000000000065 - 0000000000000065] | Motherboard resources             |
| ▶ | [0000000000000067 - 0000000000000067] | Motherboard resources             |
| ▶ | [0000000000000070 - 0000000000000070] | Motherboard resources             |

|   |                                       |                                   |
|---|---------------------------------------|-----------------------------------|
|    | [000000000000067 - 000000000000067]   | Motherboard resources             |
|    | [000000000000070 - 000000000000070]   | Motherboard resources             |
|    | [000000000000080 - 000000000000080]   | Motherboard resources             |
|    | [000000000000092 - 000000000000092]   | Motherboard resources             |
|    | [0000000000000A0 - 0000000000000A1]   | Programmable interrupt controller |
|    | [0000000000000A0 - 0000000000000A1]   | Programmable interrupt controller |
|    | [0000000000000A0 - 0000000000000A1]   | Programmable interrupt controller |
|    | [0000000000000A0 - 0000000000000A1]   | Programmable interrupt controller |
|    | [0000000000000A4 - 0000000000000A5]   | Programmable interrupt controller |
|    | [0000000000000A4 - 0000000000000A5]   | Programmable interrupt controller |
|    | [0000000000000A4 - 0000000000000A5]   | Programmable interrupt controller |
|    | [0000000000000A4 - 0000000000000A5]   | Programmable interrupt controller |
|    | [0000000000000A8 - 0000000000000A9]   | Programmable interrupt controller |
|    | [0000000000000A8 - 0000000000000A9]   | Programmable interrupt controller |
|    | [0000000000000A8 - 0000000000000A9]   | Programmable interrupt controller |
|    | [0000000000000A8 - 0000000000000A9]   | Programmable interrupt controller |
|    | [0000000000000AC - 0000000000000AD]   | Programmable interrupt controller |
|    | [0000000000000AC - 0000000000000AD]   | Programmable interrupt controller |
|    | [0000000000000AC - 0000000000000AD]   | Programmable interrupt controller |
|    | [0000000000000AC - 0000000000000AD]   | Programmable interrupt controller |
|    | [0000000000000B0 - 0000000000000B1]   | Programmable interrupt controller |
|    | [0000000000000B0 - 0000000000000B1]   | Programmable interrupt controller |
|    | [0000000000000B0 - 0000000000000B1]   | Programmable interrupt controller |
|    | [0000000000000B0 - 0000000000000B1]   | Programmable interrupt controller |
|    | [0000000000000B2 - 0000000000000B3]   | Motherboard resources             |
|    | [0000000000000B4 - 0000000000000B5]   | Programmable interrupt controller |
|    | [0000000000000B4 - 0000000000000B5]   | Programmable interrupt controller |
|    | [0000000000000B4 - 0000000000000B5]   | Programmable interrupt controller |
|    | [0000000000000B4 - 0000000000000B5]   | Programmable interrupt controller |
|    | [0000000000000B8 - 0000000000000B9]   | Programmable interrupt controller |
|    | [0000000000000B8 - 0000000000000B9]   | Programmable interrupt controller |
|    | [0000000000000B8 - 0000000000000B9]   | Programmable interrupt controller |
|   | [0000000000000B8 - 0000000000000B9]   | Programmable interrupt controller |
|  | [0000000000000BC - 0000000000000BD]   | Programmable interrupt controller |
|  | [0000000000000BC - 0000000000000BD]   | Programmable interrupt controller |
|  | [0000000000000BC - 0000000000000BD]   | Programmable interrupt controller |
|  | [0000000000000BC - 0000000000000BD]   | Programmable interrupt controller |
|  | [0000000000000E8 - 0000000000000EF]   | Fintek Communications Port (COM4) |
|  | [0000000000000F8 - 0000000000000FF]   | Fintek Communications Port (COM2) |
|  | [00000000000003E8 - 00000000000003EF] | Fintek Communications Port (COM3) |
|  | [00000000000003F8 - 00000000000003FF] | Fintek Communications Port (COM1) |
|  | [00000000000004D0 - 00000000000004D1] | Programmable interrupt controller |
|  | [00000000000004D0 - 00000000000004D1] | Programmable interrupt controller |
|  | [00000000000004D0 - 00000000000004D1] | Programmable interrupt controller |
|  | [00000000000004D0 - 00000000000004D1] | Programmable interrupt controller |
|  | [0000000000000680 - 000000000000069F] | Motherboard resources             |
|  | [0000000000000A00 - 0000000000000A0F] | Motherboard resources             |
|  | [0000000000000A10 - 0000000000000A1F] | Motherboard resources             |
|  | [0000000000000A20 - 0000000000000A2F] | Motherboard resources             |
|  | [0000000000000D00 - 0000000000000FFF] | PCI Express Root Complex          |
|  | [000000000000164E - 000000000000164F] | Motherboard resources             |
|  | [0000000000001800 - 00000000000018FF] | Motherboard resources             |

|   |                                       |                                   |
|---|---------------------------------------|-----------------------------------|
|    | [00000000000000B2 - 00000000000000B3] | Motherboard resources             |
|    | [00000000000000B4 - 00000000000000B5] | Programmable interrupt controller |
|    | [00000000000000B4 - 00000000000000B5] | Programmable interrupt controller |
|    | [00000000000000B4 - 00000000000000B5] | Programmable interrupt controller |
|    | [00000000000000B4 - 00000000000000B5] | Programmable interrupt controller |
|    | [00000000000000B8 - 00000000000000B9] | Programmable interrupt controller |
|    | [00000000000000B8 - 00000000000000B9] | Programmable interrupt controller |
|    | [00000000000000B8 - 00000000000000B9] | Programmable interrupt controller |
|    | [00000000000000B8 - 00000000000000B9] | Programmable interrupt controller |
|    | [00000000000000B8 - 00000000000000B9] | Programmable interrupt controller |
|    | [00000000000000B8 - 00000000000000B9] | Programmable interrupt controller |
|    | [00000000000000BC - 00000000000000BD] | Programmable interrupt controller |
|    | [00000000000000BC - 00000000000000BD] | Programmable interrupt controller |
|    | [00000000000000BC - 00000000000000BD] | Programmable interrupt controller |
|    | [00000000000000BC - 00000000000000BD] | Programmable interrupt controller |
|    | [00000000000000BC - 00000000000000BD] | Programmable interrupt controller |
|    | [00000000000002E8 - 00000000000002EF] | Fintek Communications Port (COM4) |
|    | [00000000000002F8 - 00000000000002FF] | Fintek Communications Port (COM2) |
|    | [00000000000003E8 - 00000000000003EF] | Fintek Communications Port (COM3) |
|    | [00000000000003F8 - 00000000000003FF] | Fintek Communications Port (COM1) |
|    | [00000000000004D0 - 00000000000004D1] | Programmable interrupt controller |
|    | [00000000000004D0 - 00000000000004D1] | Programmable interrupt controller |
|    | [00000000000004D0 - 00000000000004D1] | Programmable interrupt controller |
|    | [00000000000004D0 - 00000000000004D1] | Programmable interrupt controller |
|    | [0000000000000680 - 000000000000069F] | Motherboard resources             |
|    | [0000000000000A00 - 0000000000000A0F] | Motherboard resources             |
|    | [0000000000000A10 - 0000000000000A1F] | Motherboard resources             |
|    | [0000000000000A20 - 0000000000000A2F] | Motherboard resources             |
|    | [0000000000000D00 - 0000000000000FFF] | PCI Express Root Complex          |
|    | [000000000000164E - 000000000000164F] | Motherboard resources             |
|    | [0000000000001800 - 00000000000018FE] | Motherboard resources             |
|    | [0000000000001854 - 0000000000001857] | Motherboard resources             |
|   | [0000000000001854 - 0000000000001857] | Motherboard resources             |
|  | [0000000000001854 - 0000000000001857] | Motherboard resources             |
|  | [0000000000001854 - 0000000000001857] | Motherboard resources             |
|  | [0000000000002000 - 00000000000020FE] | Motherboard resources             |
|  | [0000000000003000 - 000000000000303F] | Intel(R) Iris(R) Xe Graphics      |
|  | [0000000000003000 - 0000000000003FFF] | PCI Express Root Port #9 - 54B0   |
|  | [0000000000003000 - 0000000000003FFF] | PCI-to-PCI Bridge                 |
|  | [0000000000003060 - 000000000000307F] | Standard SATA AHCI Controller     |
|  | [0000000000003080 - 0000000000003083] | Standard SATA AHCI Controller     |
|  | [0000000000003090 - 0000000000003097] | Standard SATA AHCI Controller     |
|  | [0000000000004000 - 000000000000403F] | Intel(R) UHD Graphics             |
|  | [0000000000004000 - 000000000000403F] | Intel(R) UHD Graphics             |
|  | [0000000000004000 - 000000000000403F] | Intel(R) UHD Graphics 770         |
|  | [0000000000004060 - 000000000000407F] | Standard SATA AHCI Controller     |
|  | [0000000000004060 - 000000000000407F] | Standard SATA AHCI Controller     |
|  | [0000000000004080 - 0000000000004083] | Standard SATA AHCI Controller     |
|  | [0000000000004080 - 0000000000004083] | Standard SATA AHCI Controller     |
|  | [0000000000004090 - 0000000000004097] | Standard SATA AHCI Controller     |
|  | [0000000000004090 - 0000000000004097] | Standard SATA AHCI Controller     |
|  | [000000000000EFA0 - 000000000000EFBF] | SMBus - 54A3                      |
|  | [000000000000EFA0 - 000000000000EFBF] | SM Bus Controller                 |
|  | [000000000000EFA0 - 000000000000EFBF] | SM Bus Controller                 |























































|   |  |   |
|---|--|---|
|    | [00000000FD690000 - 00000000FD69FFFF]    | Intel(R) Serial IO GPIO Host Controller - INTC1057              |
|    | [00000000FD690000 - 00000000FD69FFFF]    | Unknown device  |
|    | [00000000FD6A0000 - 00000000FD6AFFFF]    | Intel(R) Serial IO GPIO Host Controller - INTC1057              |
|    | [00000000FD6A0000 - 00000000FD6AFFFF]    | Unknown device  |
|    | [00000000FD6B0000 - 00000000FD6CFFFF]    | Motherboard resources   |
|    | [00000000FD6D0000 - 00000000FD6DFFFF]    | Intel(R) Serial IO GPIO Host Controller - INTC1057              |
|    | [00000000FD6D0000 - 00000000FD6DFFFF]    | Unknown device  |
|    | [00000000FD6E0000 - 00000000FD6EFFFF]    | Intel(R) Serial IO GPIO Host Controller - INTC1057              |
|    | [00000000FD6E0000 - 00000000FD6EFFFF]    | Unknown device  |
|    | [00000000FD6F0000 - 00000000FDFFFFFF]    | Motherboard resources   |
|    | [00000000FE000000 - 00000000FE01FFFF]    | Motherboard resources   |
|    | [00000000FE010000 - 00000000FE010FFF]    | SPI (flash) Controller - 54A4                                   |
|    | [00000000FE010000 - 00000000FE010FFF]    | PCI Device  |
|    | [00000000FE010000 - 00000000FE010FFF]    | PCI Device  |
|    | [00000000FE04C000 - 00000000FE04FFFF]    | Motherboard resources   |
|    | [00000000FE050000 - 00000000FE0AFFFF]    | Motherboard resources   |
|    | [00000000FE0D0000 - 00000000FE0FFFFF]    | Motherboard resources   |
|    | [00000000FE200000 - 00000000FE7FFFFF]    | Motherboard resources   |
|    | [00000000FED00000 - 00000000FED003FF]    | High precision event timer                                      |
|    | [00000000FED20000 - 00000000FED7FFFF]    | Motherboard resources   |
|    | [00000000FED40000 - 00000000FED44FFF]    | Trusted Platform Module 2.0                                     |
|    | [00000000FED45000 - 00000000FED8FFFF]    | Motherboard resources   |
|    | [00000000FED90000 - 00000000FED93FFF]    | Motherboard resources   |
|    | [00000000FEDA0000 - 00000000FEDA0FFF]    | Motherboard resources   |
|    | [00000000FEDA1000 - 00000000FEDA1FFF]    | Motherboard resources   |
|    | [00000000FEDC0000 - 00000000FEDC7FFF]    | Motherboard resources   |
|    | [00000000FEE00000 - 00000000FEEFFFFF]    | Motherboard resources   |
|    | [00000000FF000000 - 00000000FFFFFFFF]    | Motherboard resources   |
|    | [0000004000000000 - 000000400FFFFFFF]    | Intel(R) Iris(R) Xe Graphics                                    |
|    | [0000004000000000 - 000000400FFFFFFF]    | Intel(R) UHD Graphics   |
|    | [0000004000000000 - 000000400FFFFFFF]    | Intel(R) UHD Graphics   |
|    | [0000004000000000 - 000000400FFFFFFF]    | Intel(R) UHD Graphics 770                                       |
|   | [0000006000000000 - 00000060009FFFFF]    | PCI Express Root Port #9 - 54B0                                 |
|  | [0000006000000000 - 00000060009FFFFF]    | PCI-to-PCI Bridge   |
|  | [0000006000000000 - 0000006000FFFFFF]    | Intel(R) Iris(R) Xe Graphics                                    |
|  | [0000006001000000 - 0000006001FFFFFF]    | Intel(R) UHD Graphics   |
|  | [0000006001000000 - 0000006001FFFFFF]    | Intel(R) UHD Graphics   |
|  | [0000006001000000 - 0000006001FFFFFF]    | Intel(R) UHD Graphics 770                                       |
|  | [0000006001300000 - 000000600130FFFF]    | Intel(R) USB 3.10 eXtensible Host Controller - 1.20 (Microsoft) |
|  | [0000006001318000 - 00000060013180FF]    | SM Bus Controller   |
|  | [0000006002100000 - 000000600210FFFF]    | Intel(R) USB 3.10 eXtensible Host Controller - 1.20 (Microsoft) |
|  | [0000006002100000 - 000000600210FFFF]    | Intel(R) USB 3.20 eXtensible Host Controller - 1.20 (Microsoft) |
|  | [0000006002110000 - 0000006002117FFF]    | Intel(R) Platform Monitoring Technology Driver                  |
|  | [0000006002118000 - 00000060021180FF]    | SM Bus Controller   |
|  | [0000006002128000 - 00000060021280FF]    | SMBus - 54A3  |
|  | [00000077FFFEF8000 - 00000077FFFEF8FFF]  | Intel(R) Serial IO I2C Host Controller - 54C5                   |
|  | [00000077FFFEF9000 - 00000077FFFEF9FFF]  | Intel(R) Management Engine Interface #1                         |
|  | [00000077FFFEFA000 - 00000077FFFEFAFFF]  | Intel(R) Serial IO I2C Host Controller - 54E8                   |
|  | [00000077FFFEFB000 - 00000077FFFEFBFFF]  | Intel(R) Serial IO UART Host Controller - 54A8                  |
|  | [00000077FFFEFC000 - 00000077FFFEFCFFF]  | Intel® Smart Sound Technology BUS                               |
|  | [00000077FFFEFD0000 - 00000077FFFEFDFFF] | Intel® Smart Sound Technology BUS                               |

## A.3 IRQ Mapping Chart















































| Interrupt request (IRQ) |  |
|-------------------------|--|
| (ISA) 0x00000000 (00)   | System timer                                       |
| (ISA) 0x00000000 (00)   | System timer                                       |
| (ISA) 0x00000000 (00)   | System timer                                       |
| (ISA) 0x00000000 (00)   | System timer                                       |
| (ISA) 0x00000001 (01)   | Standard PS/2 Keyboard                             |
| (ISA) 0x00000003 (03)   | Fintek Communications Port (COM2)                  |
| (ISA) 0x00000004 (04)   | Fintek Communications Port (COM1)                  |
| (ISA) 0x00000006 (06)   | Fintek Communications Port (COM4)                  |
| (ISA) 0x00000007 (07)   | Fintek Communications Port (COM3)                  |
| (ISA) 0x0000000C (12)   | PS/2 Compatible Mouse                              |
| (ISA) 0x0000000E (14)   | Intel(R) Serial IO GPIO Host Controller - INTC1057 |
| (ISA) 0x0000000E (14)   | Unknown device                                     |
| (ISA) 0x0000000E (14)   | Unknown device                                     |
| (ISA) 0x00000037 (55)   | Microsoft ACPI-Compliant System                    |
| (ISA) 0x00000038 (56)   | Microsoft ACPI-Compliant System                    |
| (ISA) 0x00000039 (57)   | Microsoft ACPI-Compliant System                    |
| (ISA) 0x0000003A (58)   | Microsoft ACPI-Compliant System                    |
| (ISA) 0x0000003B (59)   | Microsoft ACPI-Compliant System                    |
| (ISA) 0x0000003C (60)   | Microsoft ACPI-Compliant System                    |
| (ISA) 0x0000003D (61)   | Microsoft ACPI-Compliant System                    |
| (ISA) 0x0000003E (62)   | Microsoft ACPI-Compliant System                    |
| (ISA) 0x0000003F (63)   | Microsoft ACPI-Compliant System                    |
| (ISA) 0x00000040 (64)   | Microsoft ACPI-Compliant System                    |
| (ISA) 0x00000041 (65)   | Microsoft ACPI-Compliant System                    |
| (ISA) 0x00000042 (66)   | Microsoft ACPI-Compliant System                    |
| (ISA) 0x00000043 (67)   | Microsoft ACPI-Compliant System                    |
| (ISA) 0x00000044 (68)   | Microsoft ACPI-Compliant System                    |
| (ISA) 0x00000045 (69)   | Microsoft ACPI-Compliant System                    |
| (ISA) 0x00000046 (70)   | Microsoft ACPI-Compliant System                    |
| (ISA) 0x00000047 (71)   | Microsoft ACPI-Compliant System                    |
| (ISA) 0x00000048 (72)   | Microsoft ACPI-Compliant System                    |
| (ISA) 0x00000049 (73)   | Microsoft ACPI-Compliant System                    |
| (ISA) 0x0000004A (74)   | Microsoft ACPI-Compliant System                    |
| (ISA) 0x0000004B (75)   | Microsoft ACPI-Compliant System                    |
| (ISA) 0x0000004C (76)   | Microsoft ACPI-Compliant System                    |
| (ISA) 0x0000004D (77)   | Microsoft ACPI-Compliant System                    |
| (ISA) 0x0000004E (78)   | Microsoft ACPI-Compliant System                    |
| (ISA) 0x0000004F (79)   | Microsoft ACPI-Compliant System                    |
| (ISA) 0x00000050 (80)   | Microsoft ACPI-Compliant System                    |
| (ISA) 0x00000051 (81)   | Microsoft ACPI-Compliant System                    |
| (ISA) 0x00000052 (82)   | Microsoft ACPI-Compliant System                    |
| (ISA) 0x00000053 (83)   | Microsoft ACPI-Compliant System                    |
| (ISA) 0x00000054 (84)   | Microsoft ACPI-Compliant System                    |
| (ISA) 0x00000055 (85)   | Microsoft ACPI-Compliant System                    |
| (ISA) 0x00000056 (86)   | Microsoft ACPI-Compliant System                    |
| (ISA) 0x00000057 (87)   | Microsoft ACPI-Compliant System                    |
| (ISA) 0x00000058 (88)   | Microsoft ACPI-Compliant System                    |
| (ISA) 0x00000059 (89)   | Microsoft ACPI-Compliant System                    |
| (ISA) 0x0000005A (90)   | Microsoft ACPI-Compliant System                    |
| (ISA) 0x0000005B (91)   | Microsoft ACPI-Compliant System                    |
| (ISA) 0x0000005C (92)   | Microsoft ACPI-Compliant System                    |

---

|  |                                 |
|--|---------------------------------|
|  (ISA) 0x0000005D (93)    | Microsoft ACPI-Compliant System |
|  (ISA) 0x0000005E (94)    | Microsoft ACPI-Compliant System |
|  (ISA) 0x0000005F (95)    | Microsoft ACPI-Compliant System |
|  (ISA) 0x00000060 (96)    | Microsoft ACPI-Compliant System |
|  (ISA) 0x00000061 (97)    | Microsoft ACPI-Compliant System |
|  (ISA) 0x00000062 (98)    | Microsoft ACPI-Compliant System |
|  (ISA) 0x00000063 (99)    | Microsoft ACPI-Compliant System |
|  (ISA) 0x00000064 (100)   | Microsoft ACPI-Compliant System |
|  (ISA) 0x00000065 (101)   | Microsoft ACPI-Compliant System |
|  (ISA) 0x00000066 (102)   | Microsoft ACPI-Compliant System |
|  (ISA) 0x00000067 (103)   | Microsoft ACPI-Compliant System |
|  (ISA) 0x00000068 (104)   | Microsoft ACPI-Compliant System |
|  (ISA) 0x00000069 (105)   | Microsoft ACPI-Compliant System |
|  (ISA) 0x0000006A (106)   | Microsoft ACPI-Compliant System |
|  (ISA) 0x0000006B (107)   | Microsoft ACPI-Compliant System |
|  (ISA) 0x0000006C (108)   | Microsoft ACPI-Compliant System |
|  (ISA) 0x0000006D (109)   | Microsoft ACPI-Compliant System |
|  (ISA) 0x0000006E (110)   | Microsoft ACPI-Compliant System |
|  (ISA) 0x0000006F (111)   | Microsoft ACPI-Compliant System |
|  (ISA) 0x00000070 (112)   | Microsoft ACPI-Compliant System |
|  (ISA) 0x00000071 (113)   | Microsoft ACPI-Compliant System |
|  (ISA) 0x00000072 (114)   | Microsoft ACPI-Compliant System |
|  (ISA) 0x00000073 (115)   | Microsoft ACPI-Compliant System |
|  (ISA) 0x00000074 (116)   | Microsoft ACPI-Compliant System |
|  (ISA) 0x00000075 (117)   | Microsoft ACPI-Compliant System |
|  (ISA) 0x00000076 (118)   | Microsoft ACPI-Compliant System |
|  (ISA) 0x00000077 (119)   | Microsoft ACPI-Compliant System |
|  (ISA) 0x00000078 (120)   | Microsoft ACPI-Compliant System |
|  (ISA) 0x00000079 (121)   | Microsoft ACPI-Compliant System |
|  (ISA) 0x0000007A (122)   | Microsoft ACPI-Compliant System |
|  (ISA) 0x0000007B (123)   | Microsoft ACPI-Compliant System |
|  (ISA) 0x0000007C (124)   | Microsoft ACPI-Compliant System |
|  (ISA) 0x0000007D (125)  | Microsoft ACPI-Compliant System |
|  (ISA) 0x0000007E (126) | Microsoft ACPI-Compliant System |
|  (ISA) 0x0000007F (127) | Microsoft ACPI-Compliant System |
|  (ISA) 0x00000080 (128) | Microsoft ACPI-Compliant System |
|  (ISA) 0x00000081 (129) | Microsoft ACPI-Compliant System |
|  (ISA) 0x00000082 (130) | Microsoft ACPI-Compliant System |
|  (ISA) 0x00000083 (131) | Microsoft ACPI-Compliant System |
|  (ISA) 0x00000084 (132) | Microsoft ACPI-Compliant System |
|  (ISA) 0x00000085 (133) | Microsoft ACPI-Compliant System |
|  (ISA) 0x00000086 (134) | Microsoft ACPI-Compliant System |
|  (ISA) 0x00000087 (135) | Microsoft ACPI-Compliant System |
|  (ISA) 0x00000088 (136) | Microsoft ACPI-Compliant System |
|  (ISA) 0x00000089 (137) | Microsoft ACPI-Compliant System |
|  (ISA) 0x0000008A (138) | Microsoft ACPI-Compliant System |
|  (ISA) 0x0000008B (139) | Microsoft ACPI-Compliant System |
|  (ISA) 0x0000008C (140) | Microsoft ACPI-Compliant System |
|  (ISA) 0x0000008D (141) | Microsoft ACPI-Compliant System |
|  (ISA) 0x0000008E (142) | Microsoft ACPI-Compliant System |
|  (ISA) 0x0000008F (143) | Microsoft ACPI-Compliant System |
|  (ISA) 0x00000090 (144) | Microsoft ACPI-Compliant System |





















































---

---











































|  |                                 |
|--|---------------------------------|
|  (ISA) 0x00000091 (145)   | Microsoft ACPI-Compliant System |
|  (ISA) 0x00000092 (146)   | Microsoft ACPI-Compliant System |
|  (ISA) 0x00000093 (147)   | Microsoft ACPI-Compliant System |
|  (ISA) 0x00000094 (148)   | Microsoft ACPI-Compliant System |
|  (ISA) 0x00000095 (149)   | Microsoft ACPI-Compliant System |
|  (ISA) 0x00000096 (150)   | Microsoft ACPI-Compliant System |
|  (ISA) 0x00000097 (151)   | Microsoft ACPI-Compliant System |
|  (ISA) 0x00000098 (152)   | Microsoft ACPI-Compliant System |
|  (ISA) 0x00000099 (153)   | Microsoft ACPI-Compliant System |
|  (ISA) 0x0000009A (154)   | Microsoft ACPI-Compliant System |
|  (ISA) 0x0000009B (155)   | Microsoft ACPI-Compliant System |
|  (ISA) 0x0000009C (156)   | Microsoft ACPI-Compliant System |
|  (ISA) 0x0000009D (157)   | Microsoft ACPI-Compliant System |
|  (ISA) 0x0000009E (158)   | Microsoft ACPI-Compliant System |
|  (ISA) 0x0000009F (159)   | Microsoft ACPI-Compliant System |
|  (ISA) 0x000000A0 (160)   | Microsoft ACPI-Compliant System |
|  (ISA) 0x000000A1 (161)   | Microsoft ACPI-Compliant System |
|  (ISA) 0x000000A2 (162)   | Microsoft ACPI-Compliant System |
|  (ISA) 0x000000A3 (163)   | Microsoft ACPI-Compliant System |
|  (ISA) 0x000000A4 (164)   | Microsoft ACPI-Compliant System |
|  (ISA) 0x000000A5 (165)   | Microsoft ACPI-Compliant System |
|  (ISA) 0x000000A6 (166)   | Microsoft ACPI-Compliant System |
|  (ISA) 0x000000A7 (167)   | Microsoft ACPI-Compliant System |
|  (ISA) 0x000000A8 (168)   | Microsoft ACPI-Compliant System |
|  (ISA) 0x000000A9 (169)   | Microsoft ACPI-Compliant System |
|  (ISA) 0x000000AA (170)   | Microsoft ACPI-Compliant System |
|  (ISA) 0x000000AB (171)   | Microsoft ACPI-Compliant System |
|  (ISA) 0x000000AC (172)  | Microsoft ACPI-Compliant System |
|  (ISA) 0x000000AD (173) | Microsoft ACPI-Compliant System |
|  (ISA) 0x000000AE (174) | Microsoft ACPI-Compliant System |
|  (ISA) 0x000000AF (175) | Microsoft ACPI-Compliant System |
|  (ISA) 0x000000B0 (176) | Microsoft ACPI-Compliant System |
|  (ISA) 0x000000B1 (177) | Microsoft ACPI-Compliant System |
|  (ISA) 0x000000B2 (178) | Microsoft ACPI-Compliant System |
|  (ISA) 0x000000B3 (179) | Microsoft ACPI-Compliant System |
|  (ISA) 0x000000B4 (180) | Microsoft ACPI-Compliant System |
|  (ISA) 0x000000B5 (181) | Microsoft ACPI-Compliant System |
|  (ISA) 0x000000B6 (182) | Microsoft ACPI-Compliant System |
|  (ISA) 0x000000B7 (183) | Microsoft ACPI-Compliant System |
|  (ISA) 0x000000B8 (184) | Microsoft ACPI-Compliant System |
|  (ISA) 0x000000B9 (185) | Microsoft ACPI-Compliant System |
|  (ISA) 0x000000BA (186) | Microsoft ACPI-Compliant System |
|  (ISA) 0x000000BB (187) | Microsoft ACPI-Compliant System |
|  (ISA) 0x000000BC (188) | Microsoft ACPI-Compliant System |
|  (ISA) 0x000000BD (189) | Microsoft ACPI-Compliant System |
|  (ISA) 0x000000BE (190) | Microsoft ACPI-Compliant System |
|  (ISA) 0x000000BF (191) | Microsoft ACPI-Compliant System |
|  (ISA) 0x000000C0 (192) | Microsoft ACPI-Compliant System |
|  (ISA) 0x000000C1 (193) | Microsoft ACPI-Compliant System |
|  (ISA) 0x000000C2 (194) | Microsoft ACPI-Compliant System |
|  (ISA) 0x000000C3 (195) | Microsoft ACPI-Compliant System |
|  (ISA) 0x000000C4 (196) | Microsoft ACPI-Compliant System |





















































---

---





















































|  |                                 |
|--|---------------------------------|
|  (ISA) 0x00000C5 (197)    | Microsoft ACPI-Compliant System |
|  (ISA) 0x00000C6 (198)    | Microsoft ACPI-Compliant System |
|  (ISA) 0x00000C7 (199)    | Microsoft ACPI-Compliant System |
|  (ISA) 0x00000C8 (200)    | Microsoft ACPI-Compliant System |
|  (ISA) 0x00000C9 (201)    | Microsoft ACPI-Compliant System |
|  (ISA) 0x00000CA (202)    | Microsoft ACPI-Compliant System |
|  (ISA) 0x00000CB (203)    | Microsoft ACPI-Compliant System |
|  (ISA) 0x00000CC (204)    | Microsoft ACPI-Compliant System |
|  (ISA) 0x00000100 (256)   | Microsoft ACPI-Compliant System |
|  (ISA) 0x00000101 (257)   | Microsoft ACPI-Compliant System |
|  (ISA) 0x00000102 (258)   | Microsoft ACPI-Compliant System |
|  (ISA) 0x00000103 (259)   | Microsoft ACPI-Compliant System |
|  (ISA) 0x00000104 (260)   | Microsoft ACPI-Compliant System |
|  (ISA) 0x00000105 (261)   | Microsoft ACPI-Compliant System |
|  (ISA) 0x00000106 (262)   | Microsoft ACPI-Compliant System |
|  (ISA) 0x00000107 (263)   | Microsoft ACPI-Compliant System |
|  (ISA) 0x00000108 (264)   | Microsoft ACPI-Compliant System |
|  (ISA) 0x00000109 (265)   | Microsoft ACPI-Compliant System |
|  (ISA) 0x0000010A (266)   | Microsoft ACPI-Compliant System |
|  (ISA) 0x0000010B (267)   | Microsoft ACPI-Compliant System |
|  (ISA) 0x0000010C (268)   | Microsoft ACPI-Compliant System |
|  (ISA) 0x0000010D (269)   | Microsoft ACPI-Compliant System |
|  (ISA) 0x0000010E (270)   | Microsoft ACPI-Compliant System |
|  (ISA) 0x0000010F (271)   | Microsoft ACPI-Compliant System |
|  (ISA) 0x00000110 (272)   | Microsoft ACPI-Compliant System |
|  (ISA) 0x00000111 (273)   | Microsoft ACPI-Compliant System |
|  (ISA) 0x00000112 (274)   | Microsoft ACPI-Compliant System |
|  (ISA) 0x00000113 (275)   | Microsoft ACPI-Compliant System |
|  (ISA) 0x00000114 (276)   | Microsoft ACPI-Compliant System |
|  (ISA) 0x00000115 (277)   | Microsoft ACPI-Compliant System |
|  (ISA) 0x00000116 (278)   | Microsoft ACPI-Compliant System |
|  (ISA) 0x00000117 (279)   | Microsoft ACPI-Compliant System |
|  (ISA) 0x00000118 (280)   | Microsoft ACPI-Compliant System |
|  (ISA) 0x00000119 (281)   | Microsoft ACPI-Compliant System |
|  (ISA) 0x0000011A (282)   | Microsoft ACPI-Compliant System |
|  (ISA) 0x0000011B (283)   | Microsoft ACPI-Compliant System |
|  (ISA) 0x0000011C (284)  | Microsoft ACPI-Compliant System |
|  (ISA) 0x0000011D (285) | Microsoft ACPI-Compliant System |
|  (ISA) 0x0000011E (286) | Microsoft ACPI-Compliant System |
|  (ISA) 0x0000011F (287) | Microsoft ACPI-Compliant System |
|  (ISA) 0x00000120 (288) | Microsoft ACPI-Compliant System |
|  (ISA) 0x00000121 (289) | Microsoft ACPI-Compliant System |
|  (ISA) 0x00000122 (290) | Microsoft ACPI-Compliant System |
|  (ISA) 0x00000123 (291) | Microsoft ACPI-Compliant System |
|  (ISA) 0x00000124 (292) | Microsoft ACPI-Compliant System |
|  (ISA) 0x00000125 (293) | Microsoft ACPI-Compliant System |
|  (ISA) 0x00000126 (294) | Microsoft ACPI-Compliant System |
|  (ISA) 0x00000127 (295) | Microsoft ACPI-Compliant System |
|  (ISA) 0x00000128 (296) | Microsoft ACPI-Compliant System |
|  (ISA) 0x00000129 (297) | Microsoft ACPI-Compliant System |
|  (ISA) 0x0000012A (298) | Microsoft ACPI-Compliant System |
|  (ISA) 0x0000012B (299) | Microsoft ACPI-Compliant System |

---

|  |                                 |
|--|---------------------------------|
|  (ISA) 0x0000012C (300)   | Microsoft ACPI-Compliant System |
|  (ISA) 0x0000012D (301)   | Microsoft ACPI-Compliant System |
|  (ISA) 0x0000012E (302)   | Microsoft ACPI-Compliant System |
|  (ISA) 0x0000012F (303)   | Microsoft ACPI-Compliant System |
|  (ISA) 0x00000130 (304)   | Microsoft ACPI-Compliant System |
|  (ISA) 0x00000131 (305)   | Microsoft ACPI-Compliant System |
|  (ISA) 0x00000132 (306)   | Microsoft ACPI-Compliant System |
|  (ISA) 0x00000133 (307)   | Microsoft ACPI-Compliant System |
|  (ISA) 0x00000134 (308)   | Microsoft ACPI-Compliant System |
|  (ISA) 0x00000135 (309)   | Microsoft ACPI-Compliant System |
|  (ISA) 0x00000136 (310)   | Microsoft ACPI-Compliant System |
|  (ISA) 0x00000137 (311)   | Microsoft ACPI-Compliant System |
|  (ISA) 0x00000138 (312)   | Microsoft ACPI-Compliant System |
|  (ISA) 0x00000139 (313)   | Microsoft ACPI-Compliant System |
|  (ISA) 0x0000013A (314)   | Microsoft ACPI-Compliant System |
|  (ISA) 0x0000013B (315)   | Microsoft ACPI-Compliant System |
|  (ISA) 0x0000013C (316)   | Microsoft ACPI-Compliant System |
|  (ISA) 0x0000013D (317)   | Microsoft ACPI-Compliant System |
|  (ISA) 0x0000013E (318)   | Microsoft ACPI-Compliant System |
|  (ISA) 0x0000013F (319)   | Microsoft ACPI-Compliant System |
|  (ISA) 0x00000140 (320)   | Microsoft ACPI-Compliant System |
|  (ISA) 0x00000141 (321)   | Microsoft ACPI-Compliant System |
|  (ISA) 0x00000142 (322)   | Microsoft ACPI-Compliant System |
|  (ISA) 0x00000143 (323)   | Microsoft ACPI-Compliant System |
|  (ISA) 0x00000144 (324)   | Microsoft ACPI-Compliant System |
|  (ISA) 0x00000145 (325) | Microsoft ACPI-Compliant System |
|  (ISA) 0x00000146 (326) | Microsoft ACPI-Compliant System |
|  (ISA) 0x00000147 (327) | Microsoft ACPI-Compliant System |
|  (ISA) 0x00000148 (328) | Microsoft ACPI-Compliant System |
|  (ISA) 0x00000149 (329) | Microsoft ACPI-Compliant System |
|  (ISA) 0x0000014A (330) | Microsoft ACPI-Compliant System |
|  (ISA) 0x0000014B (331) | Microsoft ACPI-Compliant System |
|  (ISA) 0x0000014C (332) | Microsoft ACPI-Compliant System |
|  (ISA) 0x0000014D (333) | Microsoft ACPI-Compliant System |
|  (ISA) 0x0000014E (334) | Microsoft ACPI-Compliant System |
|  (ISA) 0x0000014F (335) | Microsoft ACPI-Compliant System |
|  (ISA) 0x00000150 (336) | Microsoft ACPI-Compliant System |
|  (ISA) 0x00000151 (337) | Microsoft ACPI-Compliant System |
|  (ISA) 0x00000152 (338) | Microsoft ACPI-Compliant System |
|  (ISA) 0x00000153 (339) | Microsoft ACPI-Compliant System |
|  (ISA) 0x00000154 (340) | Microsoft ACPI-Compliant System |
|  (ISA) 0x00000155 (341) | Microsoft ACPI-Compliant System |
|  (ISA) 0x00000156 (342) | Microsoft ACPI-Compliant System |
|  (ISA) 0x00000157 (343) | Microsoft ACPI-Compliant System |
|  (ISA) 0x00000158 (344) | Microsoft ACPI-Compliant System |
|  (ISA) 0x00000159 (345) | Microsoft ACPI-Compliant System |
|  (ISA) 0x0000015A (346) | Microsoft ACPI-Compliant System |
|  (ISA) 0x0000015B (347) | Microsoft ACPI-Compliant System |
|  (ISA) 0x0000015C (348) | Microsoft ACPI-Compliant System |
|  (ISA) 0x0000015D (349) | Microsoft ACPI-Compliant System |
|  (ISA) 0x0000015E (350) | Microsoft ACPI-Compliant System |
|  (ISA) 0x0000015F (351) | Microsoft ACPI-Compliant System |





















































|  |                                 |
|--|---------------------------------|
|  (ISA) 0x00000160 (352)   | Microsoft ACPI-Compliant System |
|  (ISA) 0x00000161 (353)   | Microsoft ACPI-Compliant System |
|  (ISA) 0x00000162 (354)   | Microsoft ACPI-Compliant System |
|  (ISA) 0x00000163 (355)   | Microsoft ACPI-Compliant System |
|  (ISA) 0x00000164 (356)   | Microsoft ACPI-Compliant System |
|  (ISA) 0x00000165 (357)   | Microsoft ACPI-Compliant System |
|  (ISA) 0x00000166 (358)   | Microsoft ACPI-Compliant System |
|  (ISA) 0x00000167 (359)   | Microsoft ACPI-Compliant System |
|  (ISA) 0x00000168 (360)   | Microsoft ACPI-Compliant System |
|  (ISA) 0x00000169 (361)   | Microsoft ACPI-Compliant System |
|  (ISA) 0x0000016A (362)   | Microsoft ACPI-Compliant System |
|  (ISA) 0x0000016B (363)   | Microsoft ACPI-Compliant System |
|  (ISA) 0x0000016C (364)   | Microsoft ACPI-Compliant System |
|  (ISA) 0x0000016D (365)   | Microsoft ACPI-Compliant System |
|  (ISA) 0x0000016E (366)   | Microsoft ACPI-Compliant System |
|  (ISA) 0x0000016F (367)   | Microsoft ACPI-Compliant System |
|  (ISA) 0x00000170 (368)   | Microsoft ACPI-Compliant System |
|  (ISA) 0x00000171 (369)   | Microsoft ACPI-Compliant System |
|  (ISA) 0x00000172 (370)   | Microsoft ACPI-Compliant System |
|  (ISA) 0x00000173 (371)   | Microsoft ACPI-Compliant System |
|  (ISA) 0x00000174 (372)   | Microsoft ACPI-Compliant System |
|  (ISA) 0x00000175 (373)   | Microsoft ACPI-Compliant System |
|  (ISA) 0x00000176 (374)   | Microsoft ACPI-Compliant System |
|  (ISA) 0x00000177 (375)   | Microsoft ACPI-Compliant System |
|  (ISA) 0x00000178 (376)   | Microsoft ACPI-Compliant System |
|  (ISA) 0x00000179 (377)   | Microsoft ACPI-Compliant System |
|  (ISA) 0x0000017A (378)   | Microsoft ACPI-Compliant System |
|  (ISA) 0x0000017B (379)   | Microsoft ACPI-Compliant System |
|  (ISA) 0x0000017C (380)   | Microsoft ACPI-Compliant System |
|  (ISA) 0x0000017D (381)   | Microsoft ACPI-Compliant System |
|  (ISA) 0x0000017E (382)   | Microsoft ACPI-Compliant System |
|  (ISA) 0x0000017F (383)   | Microsoft ACPI-Compliant System |
|  (ISA) 0x00000180 (384)   | Microsoft ACPI-Compliant System |
|  (ISA) 0x00000181 (385)   | Microsoft ACPI-Compliant System |
|  (ISA) 0x00000182 (386)  | Microsoft ACPI-Compliant System |
|  (ISA) 0x00000183 (387) | Microsoft ACPI-Compliant System |
|  (ISA) 0x00000184 (388) | Microsoft ACPI-Compliant System |
|  (ISA) 0x00000185 (389) | Microsoft ACPI-Compliant System |
|  (ISA) 0x00000186 (390) | Microsoft ACPI-Compliant System |
|  (ISA) 0x00000187 (391) | Microsoft ACPI-Compliant System |
|  (ISA) 0x00000188 (392) | Microsoft ACPI-Compliant System |
|  (ISA) 0x00000189 (393) | Microsoft ACPI-Compliant System |
|  (ISA) 0x0000018A (394) | Microsoft ACPI-Compliant System |
|  (ISA) 0x0000018B (395) | Microsoft ACPI-Compliant System |
|  (ISA) 0x0000018C (396) | Microsoft ACPI-Compliant System |
|  (ISA) 0x0000018D (397) | Microsoft ACPI-Compliant System |
|  (ISA) 0x0000018E (398) | Microsoft ACPI-Compliant System |
|  (ISA) 0x0000018F (399) | Microsoft ACPI-Compliant System |
|  (ISA) 0x00000190 (400) | Microsoft ACPI-Compliant System |
|  (ISA) 0x00000191 (401) | Microsoft ACPI-Compliant System |
|  (ISA) 0x00000192 (402) | Microsoft ACPI-Compliant System |
|  (ISA) 0x00000193 (403) | Microsoft ACPI-Compliant System |

---

















































|  |                                 |
|--|---------------------------------|
|  (ISA) 0x00000194 (404)   | Microsoft ACPI-Compliant System |
|  (ISA) 0x00000195 (405)   | Microsoft ACPI-Compliant System |
|  (ISA) 0x00000196 (406)   | Microsoft ACPI-Compliant System |
|  (ISA) 0x00000197 (407)   | Microsoft ACPI-Compliant System |
|  (ISA) 0x00000198 (408)   | Microsoft ACPI-Compliant System |
|  (ISA) 0x00000199 (409)   | Microsoft ACPI-Compliant System |
|  (ISA) 0x0000019A (410)   | Microsoft ACPI-Compliant System |
|  (ISA) 0x0000019B (411)   | Microsoft ACPI-Compliant System |
|  (ISA) 0x0000019C (412)   | Microsoft ACPI-Compliant System |
|  (ISA) 0x0000019D (413)   | Microsoft ACPI-Compliant System |
|  (ISA) 0x0000019E (414)   | Microsoft ACPI-Compliant System |
|  (ISA) 0x0000019F (415)   | Microsoft ACPI-Compliant System |
|  (ISA) 0x000001A0 (416)   | Microsoft ACPI-Compliant System |
|  (ISA) 0x000001A1 (417)   | Microsoft ACPI-Compliant System |
|  (ISA) 0x000001A2 (418)   | Microsoft ACPI-Compliant System |
|  (ISA) 0x000001A3 (419)   | Microsoft ACPI-Compliant System |
|  (ISA) 0x000001A4 (420)   | Microsoft ACPI-Compliant System |
|  (ISA) 0x000001A5 (421)   | Microsoft ACPI-Compliant System |
|  (ISA) 0x000001A6 (422)   | Microsoft ACPI-Compliant System |
|  (ISA) 0x000001A7 (423)   | Microsoft ACPI-Compliant System |
|  (ISA) 0x000001A8 (424)   | Microsoft ACPI-Compliant System |
|  (ISA) 0x000001A9 (425)   | Microsoft ACPI-Compliant System |
|  (ISA) 0x000001AA (426)   | Microsoft ACPI-Compliant System |
|  (ISA) 0x000001AB (427)   | Microsoft ACPI-Compliant System |
|  (ISA) 0x000001AC (428)   | Microsoft ACPI-Compliant System |
|  (ISA) 0x000001AD (429)   | Microsoft ACPI-Compliant System |
|  (ISA) 0x000001AE (430)   | Microsoft ACPI-Compliant System |
|  (ISA) 0x000001AF (431)   | Microsoft ACPI-Compliant System |
|  (ISA) 0x000001B0 (432)   | Microsoft ACPI-Compliant System |
|  (ISA) 0x000001B1 (433)   | Microsoft ACPI-Compliant System |
|  (ISA) 0x000001B2 (434)  | Microsoft ACPI-Compliant System |
|  (ISA) 0x000001B3 (435) | Microsoft ACPI-Compliant System |
|  (ISA) 0x000001B4 (436) | Microsoft ACPI-Compliant System |
|  (ISA) 0x000001B5 (437) | Microsoft ACPI-Compliant System |
|  (ISA) 0x000001B6 (438) | Microsoft ACPI-Compliant System |
|  (ISA) 0x000001B7 (439) | Microsoft ACPI-Compliant System |
|  (ISA) 0x000001B8 (440) | Microsoft ACPI-Compliant System |
|  (ISA) 0x000001B9 (441) | Microsoft ACPI-Compliant System |
|  (ISA) 0x000001BA (442) | Microsoft ACPI-Compliant System |
|  (ISA) 0x000001BB (443) | Microsoft ACPI-Compliant System |
|  (ISA) 0x000001BC (444) | Microsoft ACPI-Compliant System |
|  (ISA) 0x000001BD (445) | Microsoft ACPI-Compliant System |
|  (ISA) 0x000001BE (446) | Microsoft ACPI-Compliant System |
|  (ISA) 0x000001BF (447) | Microsoft ACPI-Compliant System |
|  (ISA) 0x000001C0 (448) | Microsoft ACPI-Compliant System |
|  (ISA) 0x000001C1 (449) | Microsoft ACPI-Compliant System |
|  (ISA) 0x000001C2 (450) | Microsoft ACPI-Compliant System |
|  (ISA) 0x000001C3 (451) | Microsoft ACPI-Compliant System |
|  (ISA) 0x000001C4 (452) | Microsoft ACPI-Compliant System |
|  (ISA) 0x000001C5 (453) | Microsoft ACPI-Compliant System |
|  (ISA) 0x000001C6 (454) | Microsoft ACPI-Compliant System |
|  (ISA) 0x000001C7 (455) | Microsoft ACPI-Compliant System |

---

---

|  |                                 |
|--|---------------------------------|
|  (ISA) 0x000001C8 (456)   | Microsoft ACPI-Compliant System |
|  (ISA) 0x000001C9 (457)   | Microsoft ACPI-Compliant System |
|  (ISA) 0x000001CA (458)   | Microsoft ACPI-Compliant System |
|  (ISA) 0x000001CB (459)   | Microsoft ACPI-Compliant System |
|  (ISA) 0x000001CC (460)   | Microsoft ACPI-Compliant System |
|  (ISA) 0x000001CD (461)   | Microsoft ACPI-Compliant System |
|  (ISA) 0x000001CE (462)   | Microsoft ACPI-Compliant System |
|  (ISA) 0x000001CF (463)   | Microsoft ACPI-Compliant System |
|  (ISA) 0x000001D0 (464)   | Microsoft ACPI-Compliant System |
|  (ISA) 0x000001D1 (465)   | Microsoft ACPI-Compliant System |
|  (ISA) 0x000001D2 (466)   | Microsoft ACPI-Compliant System |
|  (ISA) 0x000001D3 (467)   | Microsoft ACPI-Compliant System |
|  (ISA) 0x000001D4 (468)   | Microsoft ACPI-Compliant System |
|  (ISA) 0x000001D5 (469)   | Microsoft ACPI-Compliant System |
|  (ISA) 0x000001D6 (470)   | Microsoft ACPI-Compliant System |
|  (ISA) 0x000001D7 (471)   | Microsoft ACPI-Compliant System |
|  (ISA) 0x000001D8 (472)   | Microsoft ACPI-Compliant System |
|  (ISA) 0x000001D9 (473)   | Microsoft ACPI-Compliant System |
|  (ISA) 0x000001DA (474)   | Microsoft ACPI-Compliant System |
|  (ISA) 0x000001DB (475)   | Microsoft ACPI-Compliant System |
|  (ISA) 0x000001DC (476)   | Microsoft ACPI-Compliant System |
|  (ISA) 0x000001DD (477)   | Microsoft ACPI-Compliant System |
|  (ISA) 0x000001DE (478)   | Microsoft ACPI-Compliant System |
|  (ISA) 0x000001DF (479)   | Microsoft ACPI-Compliant System |
|  (ISA) 0x000001E0 (480)   | Microsoft ACPI-Compliant System |
|  (ISA) 0x000001E1 (481)   | Microsoft ACPI-Compliant System |
|  (ISA) 0x000001E2 (482)   | Microsoft ACPI-Compliant System |
|  (ISA) 0x000001E3 (483)   | Microsoft ACPI-Compliant System |
|  (ISA) 0x000001E4 (484)   | Microsoft ACPI-Compliant System |
|  (ISA) 0x000001E5 (485)   | Microsoft ACPI-Compliant System |
|  (ISA) 0x000001E6 (486)   | Microsoft ACPI-Compliant System |
|  (ISA) 0x000001E7 (487)   | Microsoft ACPI-Compliant System |
|  (ISA) 0x000001E8 (488)   | Microsoft ACPI-Compliant System |
|  (ISA) 0x000001E9 (489)   | Microsoft ACPI-Compliant System |
|  (ISA) 0x000001EA (490)   | Microsoft ACPI-Compliant System |
|  (ISA) 0x000001EB (491)   | Microsoft ACPI-Compliant System |
|  (ISA) 0x000001EC (492)   | Microsoft ACPI-Compliant System |
|  (ISA) 0x000001ED (493)  | Microsoft ACPI-Compliant System |
|  (ISA) 0x000001EE (494) | Microsoft ACPI-Compliant System |
|  (ISA) 0x000001EF (495) | Microsoft ACPI-Compliant System |
|  (ISA) 0x000001F0 (496) | Microsoft ACPI-Compliant System |
|  (ISA) 0x000001F1 (497) | Microsoft ACPI-Compliant System |
|  (ISA) 0x000001F2 (498) | Microsoft ACPI-Compliant System |
|  (ISA) 0x000001F3 (499) | Microsoft ACPI-Compliant System |
|  (ISA) 0x000001F4 (500) | Microsoft ACPI-Compliant System |
|  (ISA) 0x000001F5 (501) | Microsoft ACPI-Compliant System |
|  (ISA) 0x000001F6 (502) | Microsoft ACPI-Compliant System |
|  (ISA) 0x000001F7 (503) | Microsoft ACPI-Compliant System |
|  (ISA) 0x000001F8 (504) | Microsoft ACPI-Compliant System |
|  (ISA) 0x000001F9 (505) | Microsoft ACPI-Compliant System |
|  (ISA) 0x000001FA (506) | Microsoft ACPI-Compliant System |
|  (ISA) 0x000001FB (507) | Microsoft ACPI-Compliant System |

---

|   |                        |   |
|---|------------------------|---|
|    | (ISA) 0x000001DD (477) | Microsoft ACPI-Compliant System                                 |
|    | (ISA) 0x000001DE (478) | Microsoft ACPI-Compliant System                                 |
|    | (ISA) 0x000001DF (479) | Microsoft ACPI-Compliant System                                 |
|    | (ISA) 0x000001E0 (480) | Microsoft ACPI-Compliant System                                 |
|    | (ISA) 0x000001E1 (481) | Microsoft ACPI-Compliant System                                 |
|    | (ISA) 0x000001E2 (482) | Microsoft ACPI-Compliant System                                 |
|    | (ISA) 0x000001E3 (483) | Microsoft ACPI-Compliant System                                 |
|    | (ISA) 0x000001E4 (484) | Microsoft ACPI-Compliant System                                 |
|    | (ISA) 0x000001E5 (485) | Microsoft ACPI-Compliant System                                 |
|    | (ISA) 0x000001E6 (486) | Microsoft ACPI-Compliant System                                 |
|    | (ISA) 0x000001E7 (487) | Microsoft ACPI-Compliant System                                 |
|    | (ISA) 0x000001E8 (488) | Microsoft ACPI-Compliant System                                 |
|    | (ISA) 0x000001E9 (489) | Microsoft ACPI-Compliant System                                 |
|    | (ISA) 0x000001EA (490) | Microsoft ACPI-Compliant System                                 |
|    | (ISA) 0x000001EB (491) | Microsoft ACPI-Compliant System                                 |
|    | (ISA) 0x000001EC (492) | Microsoft ACPI-Compliant System                                 |
|    | (ISA) 0x000001ED (493) | Microsoft ACPI-Compliant System                                 |
|    | (ISA) 0x000001EE (494) | Microsoft ACPI-Compliant System                                 |
|    | (ISA) 0x000001EF (495) | Microsoft ACPI-Compliant System                                 |
|    | (ISA) 0x000001F0 (496) | Microsoft ACPI-Compliant System                                 |
|    | (ISA) 0x000001F1 (497) | Microsoft ACPI-Compliant System                                 |
|    | (ISA) 0x000001F2 (498) | Microsoft ACPI-Compliant System                                 |
|    | (ISA) 0x000001F3 (499) | Microsoft ACPI-Compliant System                                 |
|    | (ISA) 0x000001F4 (500) | Microsoft ACPI-Compliant System                                 |
|    | (ISA) 0x000001F5 (501) | Microsoft ACPI-Compliant System                                 |
|    | (ISA) 0x000001F6 (502) | Microsoft ACPI-Compliant System                                 |
|    | (ISA) 0x000001F7 (503) | Microsoft ACPI-Compliant System                                 |
|    | (ISA) 0x000001F8 (504) | Microsoft ACPI-Compliant System                                 |
|   | (ISA) 0x000001F9 (505) | Microsoft ACPI-Compliant System                                 |
|  | (ISA) 0x000001FA (506) | Microsoft ACPI-Compliant System                                 |
|  | (ISA) 0x000001FB (507) | Microsoft ACPI-Compliant System                                 |
|  | (ISA) 0x000001FC (508) | Microsoft ACPI-Compliant System                                 |
|  | (ISA) 0x000001FD (509) | Microsoft ACPI-Compliant System                                 |
|  | (ISA) 0x000001FE (510) | Microsoft ACPI-Compliant System                                 |
|  | (ISA) 0x000001FF (511) | Microsoft ACPI-Compliant System                                 |
|  | (PCI) 0x00000010 (16)  | Intel(R) Serial IO UART Host Controller - 54A8                  |
|  | (PCI) 0x0000001B (27)  | Intel(R) Serial IO I2C Host Controller - 54E8                   |
|  | (PCI) 0x0000001F (31)  | Intel(R) Serial IO I2C Host Controller - 54C5                   |
|  | (PCI) 0xFFFFFFF4 (-12) | Intel(R) Management Engine Interface #1                         |
|  | (PCI) 0xFFFFFFF5 (-11) | Intel® Smart Sound Technology BUS                               |
|  | (PCI) 0xFFFFFFF6 (-10) | Intel(R) Ethernet Controller I226-IT #2                         |
|  | (PCI) 0xFFFFFFF7 (-9)  | Intel(R) Ethernet Controller I226-IT #2                         |
|  | (PCI) 0xFFFFFFF8 (-8)  | Intel(R) Ethernet Controller I226-IT #2                         |
|  | (PCI) 0xFFFFFFF9 (-7)  | Intel(R) Ethernet Controller I226-IT                            |
|  | (PCI) 0xFFFFFFFA (-6)  | Intel(R) Ethernet Controller I226-IT                            |
|  | (PCI) 0xFFFFFFFB (-5)  | Intel(R) Ethernet Controller I226-IT                            |
|  | (PCI) 0xFFFFFFFC (-4)  | Intel(R) USB 3.10 eXtensible Host Controller - 1.20 (Microsoft) |
|  | (PCI) 0xFFFFFFFDD (-3) | Intel(R) UHD Graphics   |
|  | (PCI) 0xFFFFFFFEE (-2) | Standard SATA AHCI Controller                                   |

# Appendix B

---

Mating Connectors and Cables

## B.1 Mating Connectors and Cables

| Label                        | Function                                    | Mating Connector |                   | Available Cable          | Cable P/N  |
|------------------------------|---|------------------|-------------------|--------------------------|------------|
|                              |   | Vendor           | Model no          |                          |            |
| CN1<br>CN11<br>CN24<br>CN25  | USB 2.0 Port                                | Molex            | 51021-0500        | USB2.0 Cable             | 1700050207 |
| CN2                          | 4-pin Smart FAN                             | Molex            | 51021-0400        | N/A                      | N/A        |
| CN4                          | +5V Output for SATA HDD                     | JST              | PHR-2             | SATA Power Cable         | 1702150155 |
| CN5                          | Port 80 Debug Port                          | JST              | SHR-10V-S-B       | Port 80 Debug Port Cable | 1703100133 |
| CN7                          | Front Panel                                 | JST              | SHR-10V-S-B       | Front Panel              | 170X000287 |
| CN8                          | eSPI/I2C/SMBus                              | JST              | SHR-05V-S-B       | eSPI/I2C/SMBus           | 170X000743 |
| CN10                         | Audio IO Port                               | Aces             | 50247-012H0H0-001 | Audio Cable              | 170X000156 |
| CN13                         | External Power Input                        | Molex            | 19211-0003        | Power Cable              | 170204010R |
| CN14                         | External +5VSB Power Input and PS_ON#       | JST              | XHP-3             | Power Cable              | 170220020B |
| CN15                         | GPIO  | Molex            | 51110-1050        | N/A                      |            |
| CN16<br>CN17<br>CN18<br>CN19 | COM Port                                    | Molex            | 51021-0900        | COM port Cable           | 1701090150 |
| CN21                         | LVDS Port                                   | JST              | SHDR-40V-S-B      | LVDS Cable               |            |
|                              | EDP Port                                    | JST              | SHDR-40V-S-B      | EDP Cable                |            |
| CN22                         | LVDS/eDP Port Inverter /Backlight Connector | JST              | SHR-06V-S-B       | LVDS Inverter Cable      | 170X000152 |
| CN23                         | RTC Battery                                 | Molex            | 51021-0200        | Battery Cable            | 175011301C |
| CN31                         | Touchscreen Connector                       | JST              | SHR-09V-S-B       | N/A                      | N/A        |