



GENE-SKU6 Rev. B

3.5" Subcompact Board

User's Manual 3rd Ed

Copyright Notice

This document is copyrighted, 2022. All rights are reserved. The original manufacturer reserves the right to make improvements to the products described in this manual at any time without notice.

No part of this manual may be reproduced, copied, translated, or transmitted in any form or by any means without the prior written permission of the original manufacturer. Information provided in this manual is intended to be accurate and reliable. However, the original manufacturer assumes no responsibility for its use, or for any infringements upon the rights of third parties that may result from its use.

The material in this document is for product information only and is subject to change without notice. While reasonable efforts have been made in the preparation of this document to assure its accuracy, AAEMON assumes no liabilities resulting from errors or omissions in this document, or from the use of the information contained herein.

AAEMON reserves the right to make changes in the product design without notice to its users.

Acknowledgement

All other products' name or trademarks are properties of their respective owners.

- Microsoft Windows is a registered trademark of Microsoft Corp.
- Intel® and Celeron® are registered trademarks of Intel Corporation
- Core™ is a trademark of Intel Corporation
- ITE is a trademark of Integrated Technology Express, Inc.
- IBM and VGA are trademarks of International Business Machines Corporation.

All other product names or trademarks are properties of their respective owners.

Packing List

Before setting up your product, please make sure the following items have been shipped:

Item	Quantity
GENE-SKU6 Rev. B	1
Heat spreader	1

If any of these items are missing or damaged, please contact your distributor or sales representative immediately.

About this Document

This User's Manual contains all the essential information, such as detailed descriptions and explanations on the product's hardware and software features (if any), its specifications, dimensions, jumper/connector settings/definitions, and driver installation instructions (if any), to facilitate users in setting up their product.

Users may refer to the product page at AAEON.com for the latest version of this document.

Note: This manual is for the GENE-SKU6 Rev. B subcompact board and is not applicable to prior revisions. If you have any questions please visit the support page at AAEON.com or contact your AAEON sales representative for assistance.

Safety Precautions

Please read the following safety instructions carefully. It is advised that you keep this manual for future references

1. All cautions and warnings on the device should be noted.
2. Make sure the power source matches the power rating of the device.
3. Position the power cord so that people cannot step on it. Do not place anything over the power cord.
4. Always completely disconnect the power before working on the system's hardware.
5. No connections should be made when the system is powered as a sudden rush of power may damage sensitive electronic components.
6. If the device is not to be used for a long time, disconnect it from the power supply to avoid damage by transient over-voltage.
7. Always disconnect this device from any AC supply before cleaning.
8. While cleaning, use a damp cloth instead of liquid or spray detergents.
9. Make sure the device is installed near a power outlet and is easily accessible.
10. Keep this device away from humidity.
11. Place the device on a solid surface during installation to prevent falls
12. Do not cover the openings on the device to ensure optimal heat dissipation.
13. Watch out for high temperatures when the system is running.
14. Do not touch the heat sink or heat spreader when the system is running
15. Never pour any liquid into the openings. This could cause fire or electric shock.
16. As most electronic components are sensitive to static electrical charge, be sure to ground yourself to prevent static charge when installing the internal components. Use a grounding wrist strap and contain all electronic components in any static-shielded containers.

17. If any of the following situations arises, please the contact our service personnel:
 - i. Damaged power cord or plug
 - ii. Liquid intrusion to the device
 - iii. Exposure to moisture
 - iv. Device is not working as expected or in a manner as described in this manual
 - v. The device is dropped or damaged
 - vi. Any obvious signs of damage displayed on the device
18. **DO NOT LEAVE THIS DEVICE IN AN UNCONTROLLED ENVIRONMENT WITH TEMPERATURES BEYOND THE DEVICE'S PERMITTED STORAGE TEMPERATURES (SEE CHAPTER 1) TO PREVENT DAMAGE.**

Warning!



This device complies with Part 15 FCC Rules. Operation is subject to the following two conditions: (1) this device may not cause harmful interference, and (2) this device must accept any interference received including interference that may cause undesired operation.

Caution:

There is a danger of explosion if the battery is incorrectly replaced. Replace only with the same or equivalent type recommended by the manufacturer. Dispose of used batteries according to the manufacturer's instructions and your local government's recycling or disposal directives.

Attention:

Il y a un risque d'explosion si la batterie est remplacée de façon incorrecte. Ne la remplacer qu'avec le même modèle ou équivalent recommandé par le constructeur. Recycler les batteries usées en accord avec les instructions du fabricant et les directives gouvernementales de recyclage.

China RoHS Requirements (CN)

产品中有毒有害物质或元素名称及含量

AAEON Main Board/ Daughter Board/ Backplane

部件名称	有毒有害物质或元素					
	铅 (Pb)	汞 (Hg)	镉 (Cd)	六价铬 (Cr(VI))	多溴联苯 (PBB)	多溴二苯醚 (PBDE)
印刷电路板 及其电子组件	○	○	○	○	○	○
外部信号 连接器及线材	○	○	○	○	○	○

O: 表示该有毒有害物质在该部件所有均质材料中的含量均在 SJ/T 11363-2006 标准规定的限量要求以下。

X: 表示该有毒有害物质至少在该部件的某一均质材料中的含量超出 SJ/T 11363-2006 标准规定的限量要求。

备注: 此产品所标示之环保使用期限, 系指在一般正常使用状况下。

China RoHS Requirement (EN)

Poisonous or Hazardous Substances or Elements in Products

AAEON Main Board/ Daughter Board/ Backplane

Component	Poisonous or Hazardous Substances or Elements					
	Lead (Pb)	Mercury (Hg)	Cadmium (Cd)	Hexavalent Chromium (Cr(VI))	Polybrominated Biphenyls (PBB)	Polybrominated Diphenyl Ethers (PBDE)
PCB & Other Components	○	○	○	○	○	○
Wires & Connectors for External Connections	○	○	○	○	○	○
<p>O: The quantity of poisonous or hazardous substances or elements found in each of the component's parts is below the SJ/T 11363-2006-stipulated requirement.</p> <p>X: The quantity of poisonous or hazardous substances or elements found in at least one of the component's parts is beyond the SJ/T 11363-2006-stipulated requirement.</p> <p>Note: The Environment Friendly Use Period as labeled on this product is applicable under normal usage only</p>						

Table of Contents

Chapter 1 - Product Specifications	1
1.1 Specifications	2
1.2 Block Diagram	6
Chapter 2 – Hardware Information	7
2.1 Dimensions	8
2.2 Jumpers and Connectors.....	10
2.3 List of Jumpers	11
2.3.1 Clear CMOS Jumper (JP1).....	11
2.3.2 LVDS Port Backlight Inverter VCC Selection (JP2).....	11
2.3.3 LVDS Port Backlight Lightness Control Mode Selection (JP3).....	12
2.3.4 LVDS Port Operating VDD Selection (JP4).....	12
2.3.5 mSATA/ Mini-Card Operating VCC Selection (JP5).....	12
2.3.6 Touch Screen 4,5,8 Wire Selection (JP6).....	12
2.3.7 Auto Power Button Enable/Disable Selection (JP7).....	12
2.3.8 COM3 Pin8 Function Selection (JP8).....	13
2.3.9 COM2 Pin8 Function Selection (JP9).....	13
2.3.10 Front Panel Connector (JP10).....	13
2.3.11 COM4 Pin8 Function Selection (JP11).....	14
2.4 List of Connectors.....	15
2.4.1 Battery (CN1).....	16
2.4.2 LVDS Port Inverter / Backlight Connector (CN7).....	17
2.4.3 BIOS Debug Port (CN8).....	18
2.4.4 LAN (RJ-45) Port 1/ Port 2 (CN9/ CN10).....	19
2.4.5 Mini-Card Slot (Full-Mini Card) (CN11).....	19
2.4.6 Mini-Card Slot (Half-Size Mini Card) (CN13).....	21
2.4.7 SATA Port (CN14).....	24

2.4.8	+5V Output for SATA HDD (CN15)	24
2.4.9	USB 3.2 Gen 1 Port 0/ Port 1 (CN18)	25
2.4.10	USB 3.2 Gen 1 Port 2/ Port 3 (CN19)	26
2.4.11	USB 2.0 Port 7/ Port 8 (CN20/ CN21)	27
2.4.12	Audio I/O Port (CN22)	27
2.4.13	Touchscreen Connector (CN23)	28
2.4.14	Digital I/O Port (CN24)	30
2.4.15	COM Port 1 RS-232 (CN25)	31
2.4.16	COM Port 4 (CN26)/ Port 2 (CN27)/ Port 3 (CN28)	32
2.4.17	LPC Port (CN29)	35
2.4.18	External Power Input (CN30)	36
2.4.19	+5VSB Output w/SMBus (CN32)	36
2.4.20	External +5VSB Input (CN33)	37
2.4.21	BIO Connector (CN35)	37
2.4.22	HDMI Connector (CN37)	41
2.4.23	VGA Connector (CN42)	42
2.4.24	Speaker Left (CN70)	43
2.4.25	Speaker Right (CN71)	43
2.4.26	LVDS Port (CN72)	44
2.4.27	CPU FAN (CN73)	45
2.5	Thermal Solution	46
2.5.1	GENE-SKU6-HSK02	46
2.5.2	GENE-SKU6-HSK03	47
2.3.3	GENE-SKU6-FAN01	48
2.6	Assembly Options	49
Chapter 3 - AMI BIOS Setup		52
3.1	System Test and Initialization	53
3.2	AMI BIOS Setup	54

3.3	Setup submenu: Main	55
3.4	Setup submenu: Advanced	56
3.4.1	Advanced: CPU Management	57
3.4.2	Advanced: SATA Configuration	59
3.4.3	Advanced: USB Configuration	60
3.4.4	Advanced: SIO Configuration	61
3.4.4.1	SIO Configuration: Serial Port 1-4 Configuration	62
3.4.5	Advanced: Hardware Monitor	64
3.4.5.1	Hardware Monitor: Smart Fan Configuration	65
3.4.6	Advanced: CSM Configuration	67
3.4.7	Advanced: Power Management	69
3.4.8	Advanced: Digital IO Port Configuration	71
3.5	Setup submenu: Chipset	72
3.5.1	Chipset: System Agent (SA) Configuration	73
3.5.1.1	System Agent (SA) Configuration: Graphics Configuration ..	74
3.5.1.2	Graphics Configuration: LVDS Panel Configuration	75
3.5.2	Chipset: PCH-IO Configuration	77
3.6	Setup submenu: Security	79
3.6.1	Secure Boot	80
3.6.1.1	Key Management	81
3.7	Setup submenu: Boot	83
3.7.1	Boot: BBS Priorities	84
3.8	Setup submenu: Save & Exit	85
Chapter 4 – Drivers Installation		86
4.1	Driver Download/Installation	87
4.2	Note on EHCI	91
Appendix A - I/O Information		92
A.1	I/O Address Map	93

A.2	Memory Address Map	94
A.3	IRQ Mapping Chart.....	95
Appendix B – Electrical Specifications for I/O Ports		96
B.1	Electrical Specifications for I/O Ports.....	97
Appendix C – Mating Connectors and Cables.....		98
C.1	Mating Connectors and Cables.....	99

Chapter 1

Product Specifications

1.1 Specifications

SYSTEM

FORM FACTOR	3.5" SubCompact Board
CPU	Intel® 6th Generation Core™ /Celeron Processor : Intel® i7-6600U (2C/4T, 2.60GHz, up to 3.40GHz) Intel® i5-6300U (2C/4T, 2.40GHz, up to 3.00GHz) Intel® i3-6100U (2C/4T, 2.30GHz) Intel® Celeron 3955U (2C/2T, 2.00GHz)
CPU TDP	15W, TDP-up 25W : i7-6600U/i5-6300U 15W : i3-6100U/Celeron 3955U
CHIPSET	Integrated with Intel® SoC
MEMORY TYPE	DDR4 up to 2133MHz, SODIMM x 1, up to 16GB, Non-ECC
BIOS	UEFI
WAKE ON LAN	Yes
WATCHDOG TIMER	255 Levels
SECURITY	TPM 2.0 (Optional)
RTC Battery	Lithium Battery 3V/240mAh
DIMENSION (L X W)	5.75" x 4" (146mm x 101.7mm)

POWER

POWER REQUIREMENT	+9-36V (Optional: +12V)
POWER SUPPLY TYPE	AT/ATX
CONNECTOR	Phoenix 2-pin Connector
POWER CONSUMPTION	Intel® i7-6600U, 6600U, DDR4 2400MHz 16GB, 0.73A at +36V

DISPLAY

CONTROLLER	Intel® HD Graphics 520/610
LVDS/eDP	LVDS Dual Channel 18/24bit x 1
Display Interface	VGA x 1 HDMI 1.4 x 1
Multiple Display	Up to 3 Simultaneous Displays

AUDIO

CODEC	Realtek ALC892/897
AUDIO INTERFACE	Line-in/Line-out/MIC
Speaker	3W Amplifier (Optional)

EXTERNAL I/O

ETHERNET	Intel® i210, 10/100/1000Base-TX, RJ-45 x 2
USB	USB 3.2 Gen 1 x 4
SERIAL PORT	—
VIDEO	HDMI 1.4 x 1 VGA x 1

INTERNAL I/O

USB	USB 2.0 x 2
SERIAL PORT	COM1 (RS232) COM2, COM3, COM4 (RS232/422/485, support 5V/12V/R1)
VIDEO	LVDS x 1
SATA	SATA III x 1 +5V SATA Power Connector x 1
AUDIO	Audio Header x 1
DIO/GPIO	8-bit
SMBus/I2C	I2C/SMBus x 1 (Default: SMBus)
Touch	4/5/8-wire Touch Controller x 1 (optional)
FAN	DC Fan x 1 (optional: Smart Fan)
SIM	--
Front Panel	HDD LED, PWR LED, Power Button, Buzzer, Reset
Others	—

EXPANSION

Mini PCI-E/mSATA	Full-size mSATA/mPCIe x 1 (Default mPCIe, select by BIOS) Half size mSATA/mPCIe x 1 (Default mSATA, select by BIOS)
M.2	—
Others	BIO x 1

ENVIRONMENT

OPERATING TEMPERATURE	32°F ~ 140°F (0°C ~ 60°C)
STORAGE TEMPERATURE	-40°F ~ 176°F (-40°C ~ 80°C)
OPERATING HUMIDITY	0% ~ 90% relative humidity, non-condensing
MTBF (HOURS)	371,039
EMC	CE/FCC Class A

1.2 Block Diagram

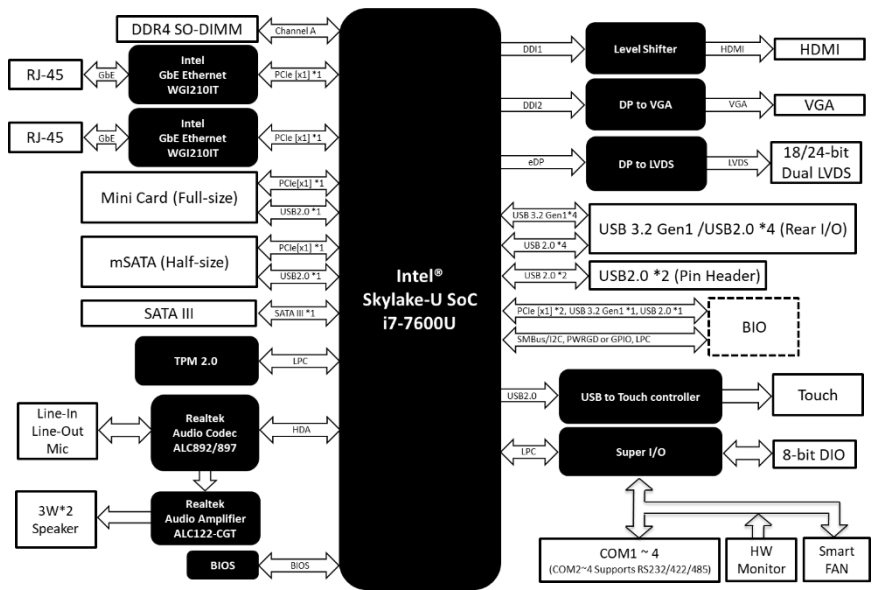

Chapter 2

Hardware Information

2.1 Dimensions

Component Side

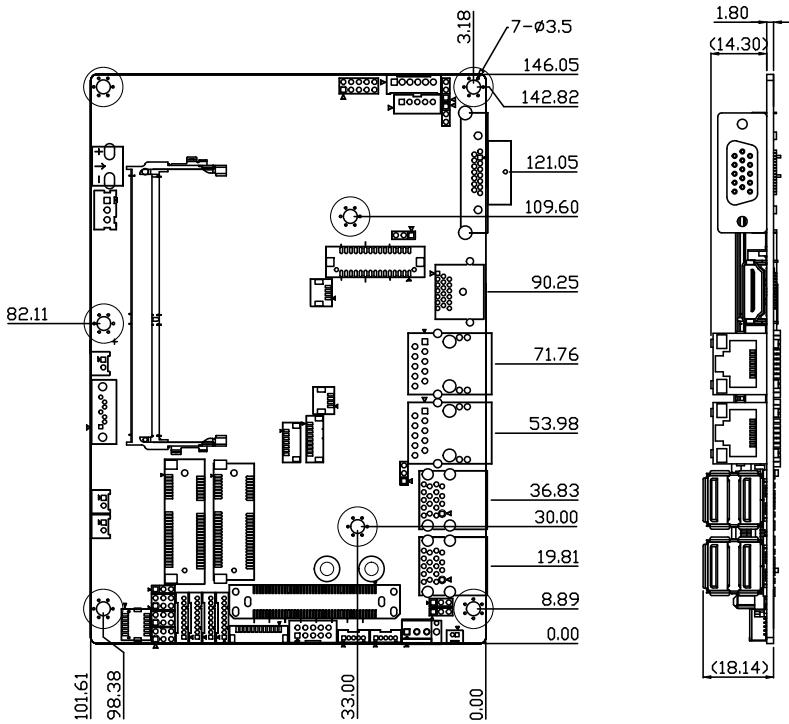

Solder Side

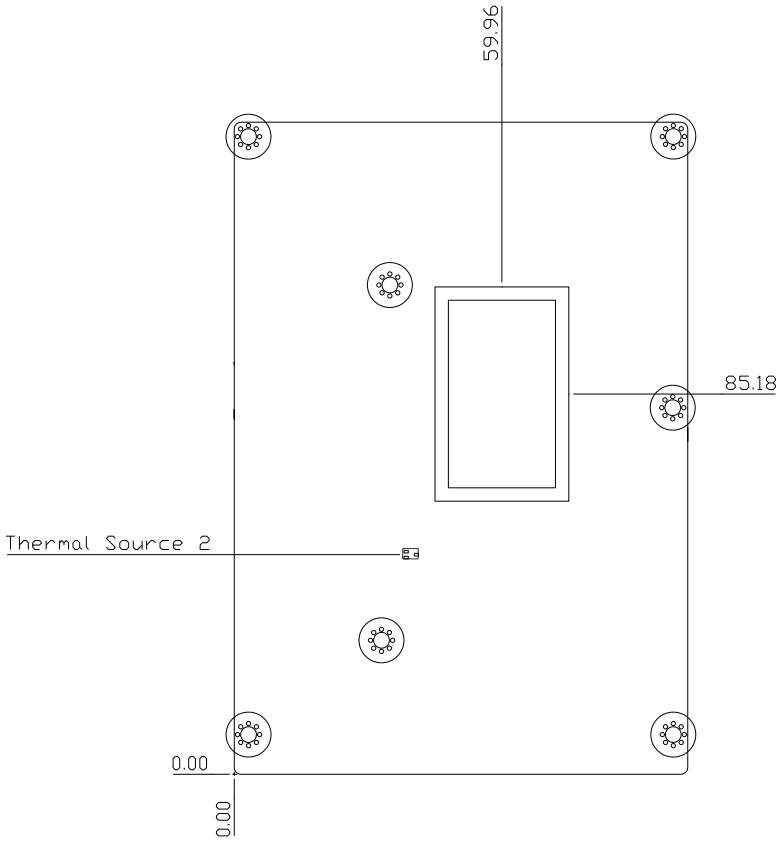

2.2 Jumpers and Connectors

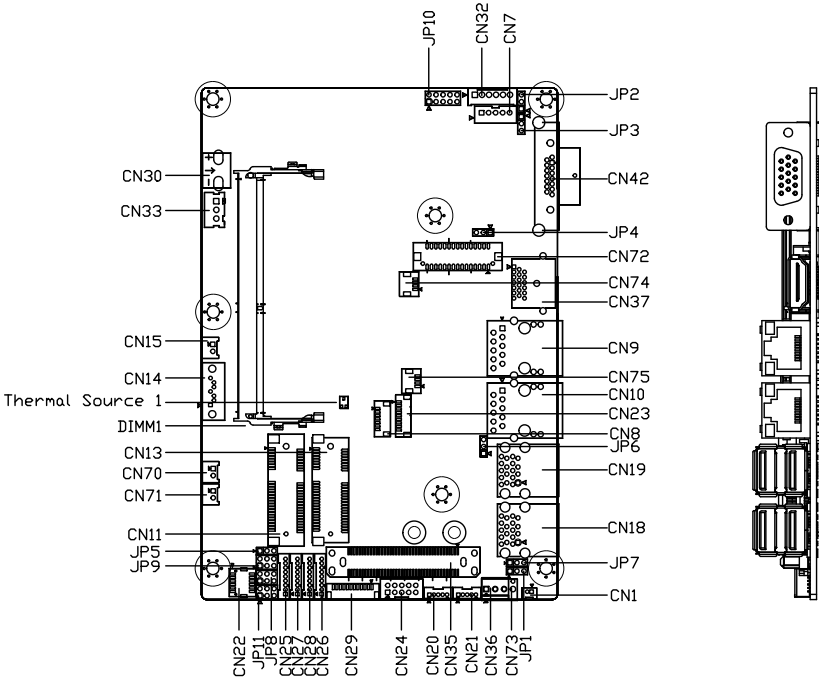

2.3 List of Jumpers

Please refer to the table below for all of the board's jumpers that you can configure for your application

Label	Function
JP1	Clear CMOS Jumper
JP2	LVDS Port Backlight Inverter VCC Selection
JP3	LVDS Port Backlight Lightness Control Mode Selection
JP4	LVDS Port Operating VDD Selection
JP5	mSATA/Mini-Card Operating VCC Selection
JP6	Touch Screen 4/5/8-wire Mode Selection
JP7	Auto Power Button Enable/Disable Selection
JP8	COM3 Pin8 Function Selection
JP9	COM2 Pin8 Function Selection
JP10	Front Panel Connector
JP11	COM4 Pin8 Function Selection

2.3.1 Clear CMOS Jumper (JP1)

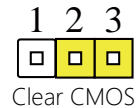
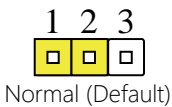

2.3.2 LVDS Port Backlight Inverter VCC Selection (JP2)

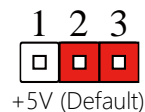
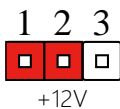

2.3.3 LVDS Port Backlight Lightness Control Mode Selection (JP3)

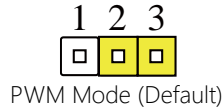
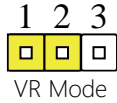

2.3.4 LVDS Port Operating VDD Selection (JP4)

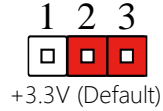
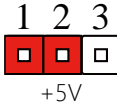

2.3.5 mSATA/ Mini-Card Operating VCC Selection (JP5)

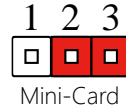
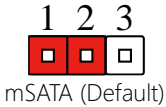

2.3.6 Touch Screen 4,5,8 Wire Selection (JP6)

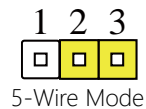
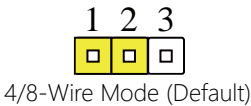

2.3.7 Auto Power Button Enable/Disable Selection (JP7)

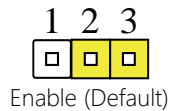
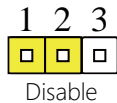

Note: When disabled, use power button JP10(1-2) to power on the system.

2.3.8 COM3 Pin8 Function Selection (JP8)

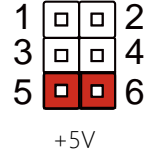
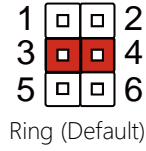
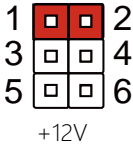

2.3.9 COM2 Pin8 Function Selection (JP9)

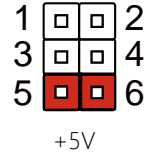
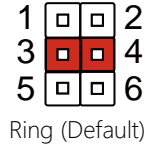
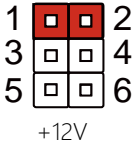

2.3.10 Front Panel Connector (JP10)

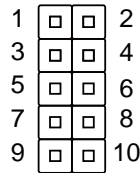

Pin	Pin Name	Pin	Pin Name
1	PWR_BTN-	2	PWR_BTN+
3	HDD_LED-	4	HDD_LED+
5	BUZZER-	6	BUZZER+
7	PWR_LED-	8	PWR_LED+
9	H/W RESET-	10	H/W RESET+

2.3.11 COM4 Pin8 Function Selection (JP11)

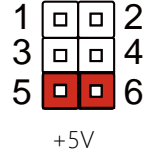
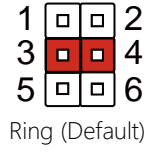
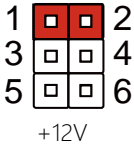

2.4 List of Connectors

Please refer to the table below for all of the board's connectors that you can configure for your application

Label	Function
CN1	RTC Battery Connector
CN7	LVDS Port Inverter / Backlight Connector
CN8	BIOS Debug Port
CN9	LAN (RJ-45) Port1
CN10	LAN (RJ-45) Port2
CN11	Mini-Card Slot (Full-size Mini Card)
CN13	Mini-Card Slot (Half-size Mini Card)
CN14	SATA Port
CN15	+5V Output for SATA HDD
CN18	USB 3.2 Gen 1 Port 0/Port 1
CN19	USB 3.2 Gen 1 Port 2/Port 3
CN20	USB 2.0 Port 7
CN21	USB 2.0 Port 8
CN22	Audio I/O Port
CN23	Touch Screen Connector
CN24	Digital IO Port
CN25	COM Port 1 RS-232
CN26	COM Port 4 RS-232/422/485
CN27	COM Port 2 RS-232/422/485
CN28	COM Port 3 RS-232/422/485
CN29	LPC Port
CN30	External Power Input
CN32	+5VSB Output w/SMBus

Label	Function
CN33	External +5VSB Input
CN35	BIO Connector
CN37	HDMI Connector
CN42	VGA Connector
CN70	Speaker Left
CN71	Speaker Right
CN72	LVDS Port
CN73	CPU FAN

2.4.1 Battery (CN1)

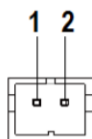

Pin	Pin Name	Signal Type	Signal Level
1	+3.3V	PWR	3.3V
2	GND	GND	

2.4.2 LVDS Port Inverter / Backlight Connector (CN7)

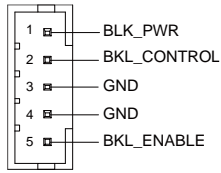

Pin	Pin Name	Signal Type	Signal Level
1	BKL_PWR	PWR	+5V / +12V
2	BKL_CONTROL	OUT	
3	GND	GND	
4	GND	GND	
5	BKL_ENABLE	OUT	+5V

Note: LVDS BKL_PWR (Pin 1) can be set by LVDS Port Backlight Inverter VCC Selection (JP2).

Note: LVDS BKL_CONTROL (Pin 2) can be set by LVDS Port Backlight Lightness Control Mode Selection (JP3)

2.4.3 BIOS Debug Port (CN8)

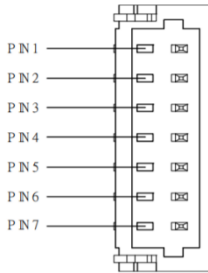

Pin	Pin Name	Signal Type	Signal Level
1	SPI_MISO	OUT	
2	GND	GND	
3	SPI_CLK	IN	
4	+3.3VSB	PWR	+3.3V
5	SPI_MOSI	IN	
6	SPI_CS	IN	
7	NC		

2.4.4 LAN (RJ-45) Port 1/ Port 2 (CN9/ CN10)

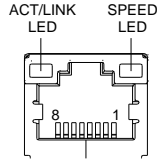

Pin	Pin Name	Signal Type	Signal Level
1	MDI0+	DIFF	
2	MDI0-	DIFF	
3	MDI1+	DIFF	
4	MDI2+	DIFF	
5	MDI2-	DIFF	
6	MDI1-	DIFF	
7	MDI3+	DIFF	
8	MDI3-	DIFF	

2.4.5 Mini-Card Slot (Full-Mini Card) (CN11)

Pin	Pin Name	Signal Type	Signal Level
1	PCIE_WAKE#	IN	
2	+3.3VSB	PWR	+3.3V
3	NC	NC	
4	GND	GND	
5	NC	NC	
6	+1.5V	PWR	+1.5V
7	PCIE_CLK_REQ#	IN	
8	NC	NC	
9	GND	GND	

Pin	Pin Name	Signal Type	Signal Level
10	NC	NC	
11	PCIE_REF_CLK-	DIFF	
12	NC	NC	
13	PCIE_REF_CLK+	DIFF	
14	NC	NC	
15	GND	GND	
16	NC	NC	
17	NC	NC	
18	GND	GND	
19	NC	NC	
20	W_DISABLE#	OUT	+3.3V
21	GND	GND	
22	PCIE_RST#	OUT	+3.3V
23	PCIE_RX-/mSATA_RX+	DIFF	
24	+3.3VSB	PWR	+3.3V
25	PCIE_RX+/mSATA_RX-	DIFF	
26	GND	GND	
27	GND	GND	
28	+1.5V	PWR	+1.5V
29	GND	GND	
30	SMB_CLK	I/O	+3.3V
31	PCIE_TX-/mSATA_TX-	DIFF	
32	SMB_DATA	I/O	+3.3V
33	PCIE_TX+/mSATA_TX+	DIFF	
34	GND	GND	
35	GND	GND	

Pin	Pin Name	Signal Type	Signal Level
36	USB_D-	DIFF	
37	GND	GND	
38	USB_D+	DIFF	
39	+3.3VSB	PWR	+3.3V
40	GND	GND	
41	+3.3VSB	PWR	+3.3V
42	NC	NC	
43	GND	GND	
44	NC	NC	
45	NC	NC	
46	NC	NC	
47	NC	NC	
48	+1.5V	PWR	+1.5V
49	NC	NC	
50	GND	GND	
51	NC	NC	
52	+3.3VSB	PWR	+3.3V

2.4.6 Mini-Card Slot (Half-Size Mini Card) (CN13)

Note: Mini-Card Slot (CN13) can be set to either Mini-Card or mSATA mode through BIOS settings.

Pin	Pin Name	Signal Type	Signal Level
1	PCIE_WAKE#	IN	
2	+3.3VSB	PWR	+3.3V
3	NC	NC	
4	GND	GND	

Pin	Pin Name	Signal Type	Signal Level
5	NC	NC	
6	+1.5V	PWR	+1.5V
7	PCIE_CLK_REQ#	IN	
8	NC	NC	
9	GND	GND	
10	NC	NC	
11	PCIE_REF_CLK-	DIFF	
12	NC	NC	
13	PCIE_REF_CLK+	DIFF	
14	NC	NC	
15	GND	GND	
16	NC	NC	
17	NC	NC	
18	GND	GND	
19	NC	NC	
20	W_DISABLE#	OUT	+3.3V
21	GND	GND	
22	PCIE_RST#	OUT	+3.3V
23	PCIE_RX-/mSATA_RX+	DIFF	
24	+3.3VSB	PWR	+3.3V
25	PCIE_RX+/mSATA_RX-	DIFF	
26	GND	GND	
27	GND	GND	
28	+1.5V	PWR	+1.5V
29	GND	GND	
30	SMB_CLK	I/O	+3.3V

Pin	Pin Name	Signal Type	Signal Level
31	PCIE_TX-/mSATA_TX-	DIFF	
32	SMB_DATA	I/O	+3.3V
33	PCIE_TX+/mSATA_TX+	DIFF	
34	GND	GND	
35	GND	GND	
36	USB_D-	DIFF	
37	GND	GND	
38	USB_D+	DIFF	
39	+3.3VSB	PWR	+3.3V
40	GND	GND	
41	+3.3VSB	PWR	+3.3V
42	NC	NC	
43	GND	GND	
44	NC	NC	
45	NC	NC	
46	NC	NC	
47	NC	NC	
48	+1.5V	PWR	+1.5V
49	NC	NC	
50	GND	GND	
51	NC	NC	
52	+3.3VSB	PWR	+3.3V

2.4.7 SATA Port (CN14)

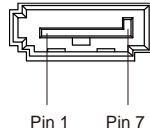

Pin	Pin Name	Signal Type	Signal Level
1	GND	GND	
2	SATA_TX+	DIFF	
3	SATA_TX-	DIFF	
4	GND	GND	
5	SATA_RX-	DIFF	
6	SATA_RX+	DIFF	
7	GND	GND	

2.4.8 +5V Output for SATA HDD (CN15)

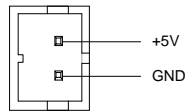

Pin	Pin Name	Signal Type	Signal Level
1	+5V	PWR	+5V
2	GND	GND	

2.4.9 USB 3.2 Gen 1 Port 0/ Port 1 (CN18)

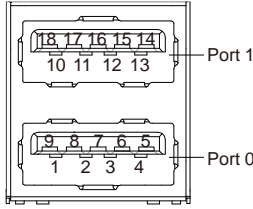

Pin	Pin Name	Signal Type	Signal Level
1	+5VSB	PWR	+5V
2	USB_D-	DIFF	
3	USB_D+	DIFF	
4	GND	GND	
5	USB_SSRX-	DIFF	
6	USB_SSRX+	DIFF	
7	GND	GND	
8	USB_SSTX-	DIFF	
9	USB_SSTX+	DIFF	
10	+5VSB	PWR	+5V
11	USB_D-	DIFF	
12	USB_D+	DIFF	
13	GND	GND	
14	USB_SSRX-	DIFF	
15	USB_SSRX+	DIFF	
16	GND	GND	
17	USB_SSTX-	DIFF	
18	USB_SSTX+	DIFF	

2.4.10 USB 3.2 Gen 1 Port 2/ Port 3 (CN19)

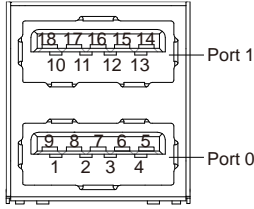

Pin	Pin Name	Signal Type	Signal Level
1	+5VSB	PWR	+5V
2	USB_D-	DIFF	
3	USB_D+	DIFF	
4	GND	GND	
5	USB_SSRX-	DIFF	
6	USB_SSRX+	DIFF	
7	GND	GND	
8	USB_SSTX-	DIFF	
9	USB_SSTX+	DIFF	
10	+5VSB	PWR	+5V
11	USB_D-	DIFF	
12	USB_D+	DIFF	
13	GND	GND	
14	USB_SSRX-	DIFF	
15	USB_SSRX+	DIFF	
16	GND	GND	
17	USB_SSTX-	DIFF	
18	USB_SSTX+	DIFF	

2.4.11 USB 2.0 Port 7/ Port 8 (CN20/ CN21)

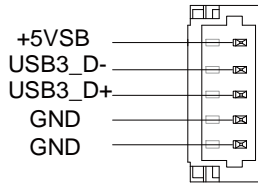

Pin	Pin Name	Signal Type	Signal Level
1	+5VSB	PWR	+5V
2	USB_D-	DIFF	
3	USB_D+	DIFF	
4	GND	GND	
5	GND	GND	

2.4.12 Audio I/O Port (CN22)

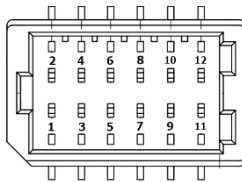

Pin	Pin Name	Signal Type	Signal Level
1	RIGHT_OUT	OUT	
2	MIC_R	IN	
3	LEFT_OUT	OUT	
4	MIC_L	IN	
5	JD_LOUT	IN	
6	JD_MIC	IN	

Pin	Pin Name	Signal Type	Signal Level
7	GND_AUDIO	GND	
8	GND_AUDIO	GND	
9	JD_LIN	IN	
10	LINE_R_IN	IN	
11	+5V_AUDIO	PWR	+5V
12	LINE_L_IN	IN	

2.4.13 Touchscreen Connector (CN23)

Note: Touch mode can be set by Touch Screen 4,5,8 Wire Selection (JP6).

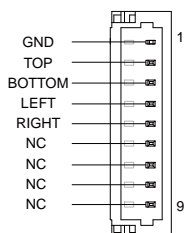

4-Wire			
Pin	Pin Name	Signal Type	Signal Level
1	GND	GND	
2	TOP	IN	
3	BOTTOM	IN	
4	LEFT	IN	
5	RIGHT	IN	
6	NC		
7	NC		
8	NC		
9	NC		

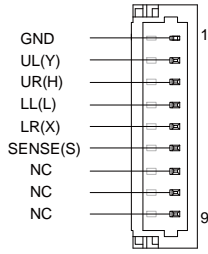

5-Wire

Pin	Pin Name	Signal Type	Signal Level
1	GND	GND	
2	UL(Y)	IN	
3	UR(H)	IN	
4	LL(L)	IN	
5	LR(X)	IN	
6	SENSE(S)	IN	
7	NC		
8	NC		
9	NC		

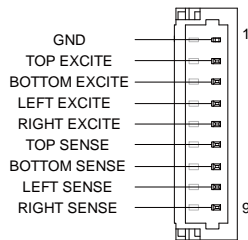

8-Wire

Pin	Pin Name	Signal Type	Signal Level
1	GND	GND	
2	TOP EXCITE	IN	

8-Wire			
Pin	Pin Name	Signal Type	Signal Level
3	BOTTOM EXCITE	IN	
4	LEFT EXCITE	IN	
5	RIGHT EXCITE	IN	
6	TOP SENSE	IN	
7	BOTTOM SENSE	IN	
8	LEFT SENSE	IN	
9	RIGHT SENSE	IN	

2.4.14 Digital I/O Port (CN24)

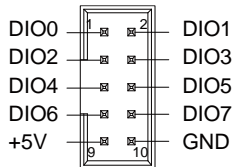

Pin	Pin Name	Signal Type	Signal Level
1	DIO0	I/O	+5V
2	DIO1	I/O	+5V
3	DIO2	I/O	+5V
4	DIO3	I/O	+5V
5	DIO4	I/O	+5V
6	DIO5	I/O	+5V
7	DIO6	I/O	+5V
8	DIO7	I/O	+5V
9	+5V	PWR	+5V
10	GND	GND	

2.4.15 COM Port 1 RS-232 (CN25)

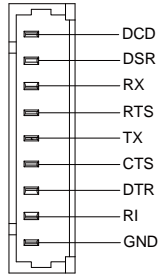

Pin	Pin Name	Signal Type	Signal Level
1	DCD	IN	
2	DSR	IN	
3	RX	IN	
4	RTS	OUT	±9V
5	TX	OUT	±9V
6	CTS	IN	
7	DTR	OUT	±9V
8	RI	IN	
9	GND	GND	

2.4.16 COM Port 4 (CN26)/ Port 2 (CN27)/ Port 3 (CN28)

COM Port RS-232/422/485 Pin Definitions

Note: COM Port 2, 3, and 4 can be set by BIOS. Default setting is RS-232.

Note: Pin 8 function can be set by Jumpers; Port 2 JP9, Port 3 JP8, Port 4 JP11.

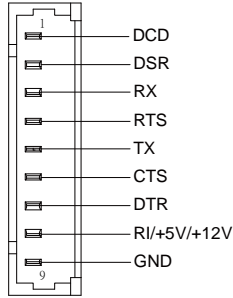

RS-232			
Pin	Pin Name	Signal Type	Signal Level
1	DCD	IN	
2	DSR	IN	
3	RX	IN	
4	RTS	OUT	±5V
5	TX	OUT	±5V
6	CTS	IN	
7	DTR	OUT	±5V
8	RI/+5V/+12V	IN/ PWR	+5V/+12V
9	GND	GND	

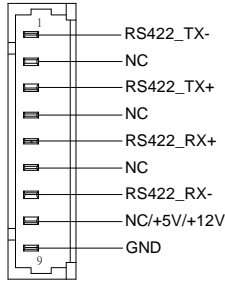

RS-422			
Pin	Pin Name	Signal Type	Signal Level
1	RS422_TX-	OUT	±5V
2	NC		
3	RS422_TX+	OUT	±5V
4	NC		
5	RS422_RX+	IN	
6	NC		
7	RS422_RX-	IN	
8	NC/+5V/+12V	PWR	+5V/+12V
9	GND	GND	

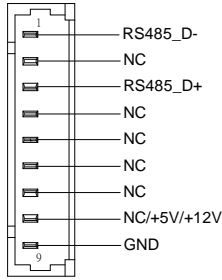

RS-485			
Pin	Pin Name	Signal Type	Signal Level
1	RS485_D-	I/O	±5V
2	NC		
3	RS485_D+	I/O	±5V
4	NC		
5	NC		
6	NC		
7	NC		
8	NC/+5V/+12V	PWR	+5V/+12V
9	GND	GND	

2.4.17 LPC Port (CN29)

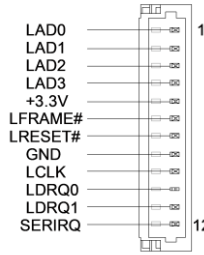

Pin	Pin Name	Signal Type	Signal Level
1	LAD0	I/O	+3.3V
2	LAD1	I/O	+3.3V
3	LAD2	I/O	+3.3V
4	LAD3	I/O	+3.3V
5	+3.3V	PWR	+3.3V
6	LFRAME#	IN	
7	LRESET#	OUT	+3.3V
8	GND	GND	
9	LCLK	OUT	
10	SMB_DATA/I2C_SDA	I/O	
11	SMB_CLK/I2C_SCL	I/O	
12	SMB_ALERT/SERIRQ	I/O	+3.3V

Note: I2C function can be set by BOM

2.4.18 External Power Input (CN30)

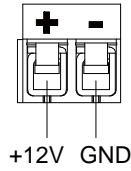

Pin	Pin Name	Signal Type	Signal Level
1	+12V	PWR	+9~+36V (or +12V)
2	GND	GND	

2.4.19 +5VSB Output w/SMBus (CN32)

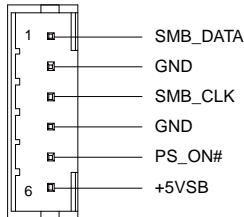

Pin	Pin Name	Signal Type	Signal Level
1	SMB_DATA	I/O	+3.3V
2	GND	GND	
3	SMB_CLK	I/O	+3.3V
4	GND	GND	
5	PS_ON#	OUT	+3.3V
6	+5VSB	PWR	+5V

2.4.20 External +5VSB Input (CN33)

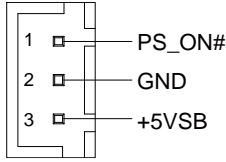

Pin	Pin Name	Signal Type	Signal Level
1	PS_ON#	OUT	+3.3V
2	GND	GND	
3	+5VSB	PWR	+5V

2.4.21 BIO Connector (CN35)

Pin	Pin Name	Signal Type	Signal Level
1	+12V_Dual	PWR	+12V
2	GND	GND	
3	GND	GND	
4	PCIE1_TX-	I/O	
5	PCIE1_RX-	I/O	
6	PCIE1_TX+	I/O	
7	PCIE1_RX+	I/O	
8	GND	GND	
9	GND	GND	
10	PCIE2_TX-	I/O	
11	PCIE2_RX-	I/O	
12	PCIE2_TX+	I/O	
13	PCIE2_RX+	I/O	
14	GND	GND	

Pin	Pin Name	Signal Type	Signal Level
15	GND	GND	
16	PS_ON#	OUT	
17	NC	NC	
18	NC	NC	
19	+5V_Dual	PWR	+5V
20	+5V_Dual	PWR	+5V
21	+5V_Dual	PWR	+5V
22	+5V_Dual	PWR	+5V
23	PCIE_CLK+	OUT	
24	PLT_RST#	OUT	
25	PCIE_CLK-	OUT	
26	GND	GND	
27	GND	GND	
28	NC	NC	
29	NC	NC	
30	NC	NC	
31	NC	NC	
32	GND	GND	
33	GND	GND	
34	NC	NC	
35	NC	NC	
36	NC	NC	
37	NC	NC	
38	GND	GND	
39	GND	GND	
40	NC	NC	

Pin	Pin Name	Signal Type	Signal Level
41	NC	NC	
42	GND	GND	
43	NC	NC	
44	USB 3.0_TX-	I/O	
45	GND	GND	
46	USB 3.0_TX+	I/O	
47	USB 2.0_D-	I/O	
48	GND	GND	
49	USB 2.0_D+	I/O	
50	USB 3.0_RX-	I/O	
51	GND	GND	
52	USB 3.0_RX+	I/O	
53	SMB_CLK	I/O	
54	GND	GND	
55	SMB_DATA	I/O	
56	PCIE_WAKE#	IN	
57	GND	GND	
58	USB 2.0_OC#	IN	
59	+5V	PWR	+5V
60	USB 2.0_OC#	IN	
61	+5V	PWR	+5V
62	+5V	PWR	+5V
63	+5V	PWR	+5V
64	+5V	PWR	+5V
65	LPC_AD0	I/O	
66	LPC_FRAME#	I/O	

Pin	Pin Name	Signal Type	Signal Level
67	LPC_AD1	I/O	
68	SERIRQ#	I/O	
69	LPC_AD2	I/O	
70	NC		
71	LPC_AD3	I/O	
72	GPIO/BIO_PWR_OK	I/O	
73	GND	GND	
74	Audio_GND	GND	
75	LPC_CLK	OUT	
76	Audio_OUT_L	OUT	
77	PME#	IN	
78	Audio_OUT_R	OUT	
79	GND	GND	
80	GND	GND	

2.4.22 HDMI Connector (CN37)

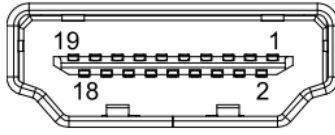

Pin	Pin Name	Signal Type	Signal Level
1	HDMI_TX2+	DIFF	
2	GND	GND	
3	HDMI_TX2-	DIFF	
4	HDMI_TX1+	DIFF	
5	GND	GND	
6	HDMI_TX1-	DIFF	
7	HDMI_TX0+	DIFF	
8	GND	GND	
9	HDMI_TX0-	DIFF	
10	HDMI_CLK+	DIFF	
11	GND	GND	
12	HDMI_CLK-	DIFF	
13	NC		
14	NC		
15	DDC_CLK	I/O	+5V
16	DDC_DATA	I/O	+5V
17	GND	GND	
18	+5V	PWR	+5V
19	HDMI_HPD		

2.4.23 VGA Connector (CN42)

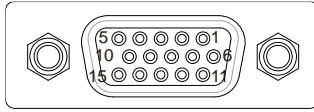

Pin	Pin Name	Signal Type	Signal Level
1	RED	OUT	
2	GREEN	OUT	
3	BLUE	OUT	
4	NC	NC	
5	GND	GND	
6	RED_GND_RTN	GND	
7	GREEN_GND_RTN	GND	
8	BLUE_GND_RTN	GND	
9	+5V	PWR	+5V
10	NC	NC	
11	NC	NC	
12	DDC_DATA	I/O	+5V
13	HSYNC	OUT	
14	VSYNC	OUT	
15	DDC_CLK	I/O	+5V

2.4.24 Speaker Left (CN70)

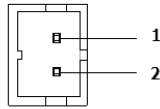

Pin	Pin Name	Signal Type	Signal Level
1	AMP_OUT_L+	O	
2	AMP_OUT_L-	O	

2.4.25 Speaker Right (CN71)

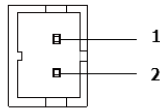

Pin	Pin Name	Signal Type	Signal Level
1	AMP_OUT_R+	O	
2	AMP_OUT_R-	O	

2.4.26 LVDS Port (CN72)

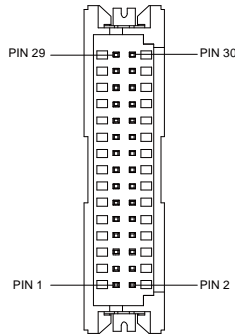

Pin	Pin Name	Signal Type	Signal Level
1	BKL_ENABLE	OUT	
2	BKL_CONTROL	OUT	
3	LCD_PWR	PWR	+3.3V/+5V
4	GND	GND	
5	LVDS_A_CLK-	DIFF	
6	LVDS_A_CLK+	DIFF	
7	LCD_PWR	PWR	+3.3V/+5V
8	GND	GND	
9	LVDS_DA0-	DIFF	
10	LVDS_DA0+	DIFF	
11	LVDS_DA1-	DIFF	
12	LVDS_DA1+	DIFF	
13	LVDS_DA2-	DIFF	
14	LVDS_DA2+	DIFF	
15	LVDS_DA3-	DIFF	
16	LVDS_DA3+	DIFF	
17	DDC_DATA	I/O	+3.3V

Pin	Pin Name	Signal Type	Signal Level
18	DDC_CLK	I/O	+3.3V
19	LVDS_DB0-		
20	LVDS_DB0+		
21	LVDS_DB1-		
22	LVDS_DB1+		
23	LVDS_DB2-		
24	LVDS_DB2+		
25	LVDS_DB3-		
26	LVDS_DB3+		
27	LCD_PWR	PWR	+3.3V/+5V
28	GND	GND	
29	LVDS_B_CLK-	DIFF	
30	LVDS_B_CLK+	DIFF	

2.4.27 CPU FAN (CN73)

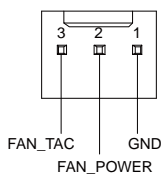

Pin	Pin Name	Signal Type	Signal Level
1	GND	GND	
2	FAN_POWER	PWR	+12V
3	FAN_TAC	IN	

2.5 Thermal Solution

2.5.1 GENE-SKU6-HSK02

One-shape heatsink, no need to use a heat spreader

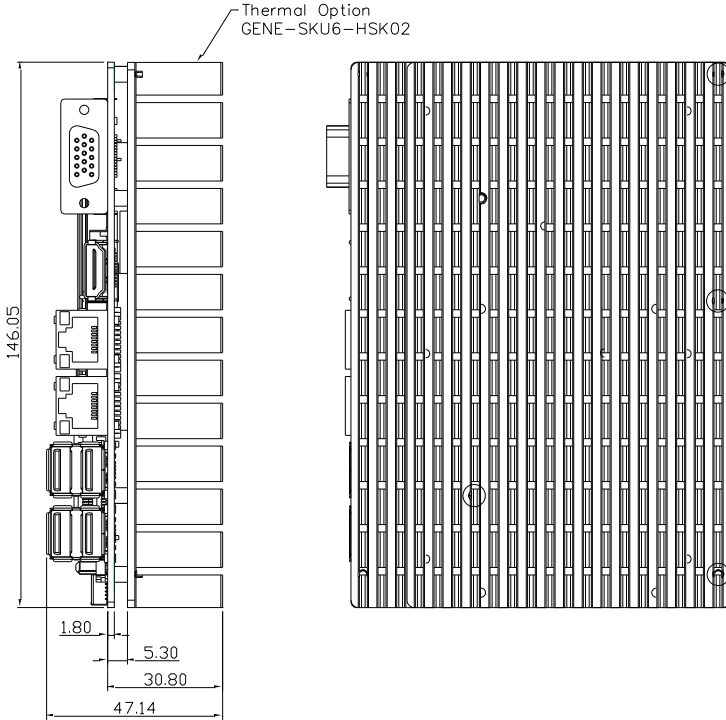

Note: It is recommended to use this configuration with a system cooler and air flow above 0.5 m/s.

2.5.2 GENE-SKU6-HSK03

Heatsink for DRAM

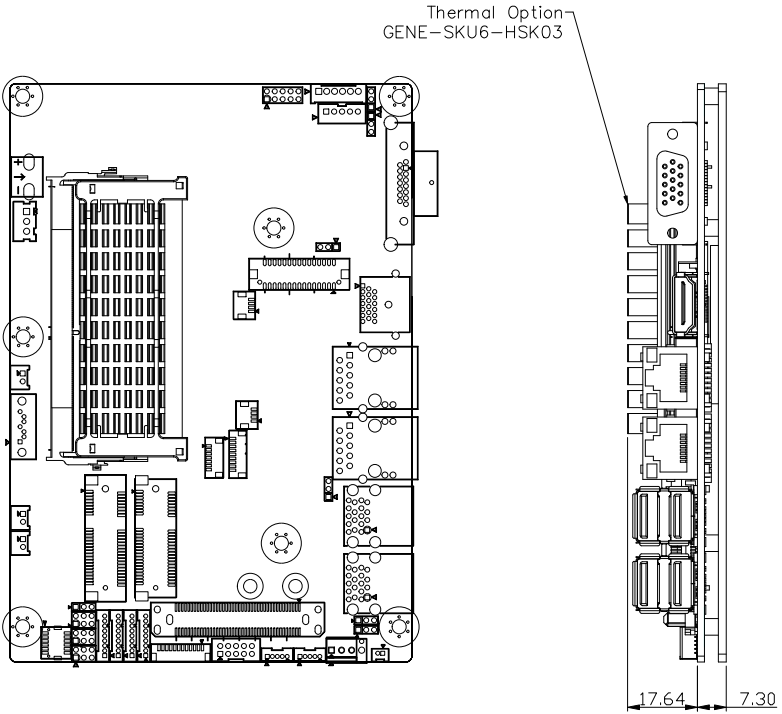

2.3.3 GENE-SKU6-FAN01

Cooler used with a heat spreader

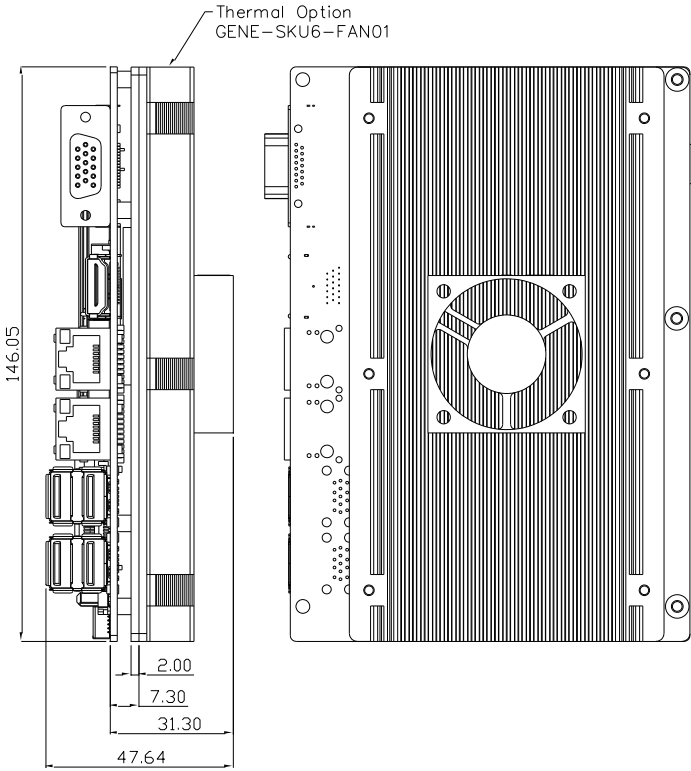

2.6 Assembly Options

Option 1

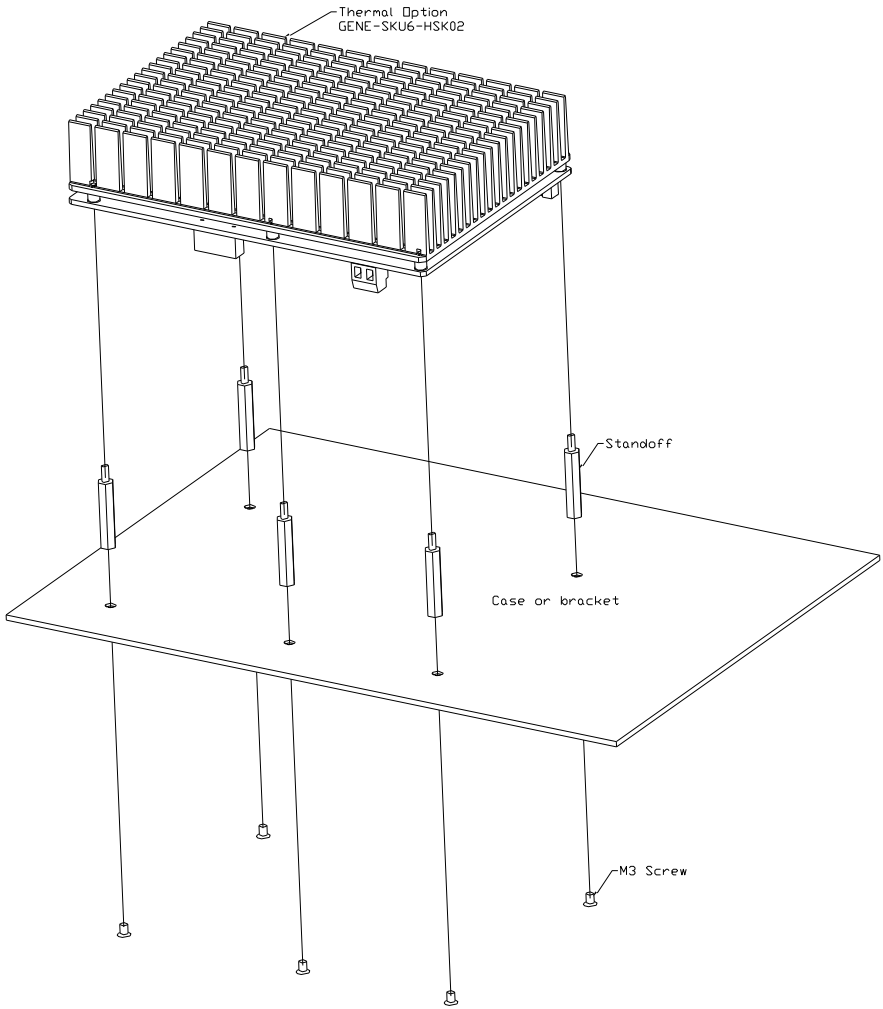

Option 2

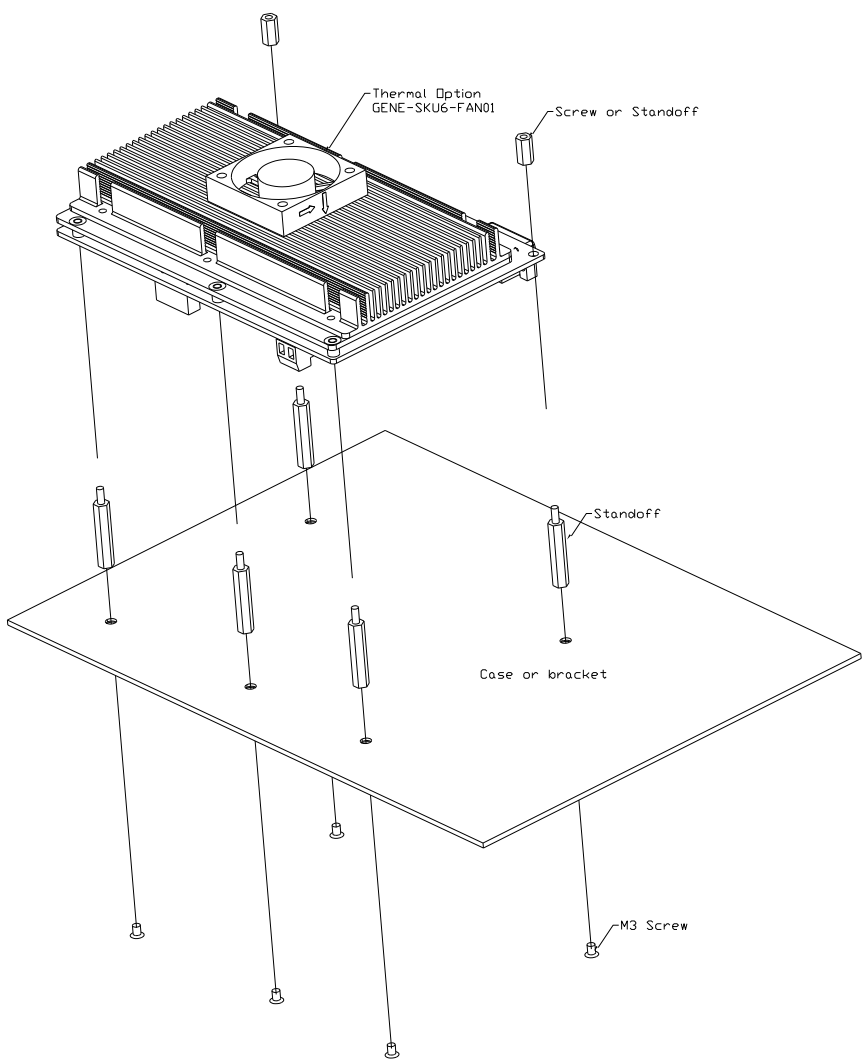

Option 3

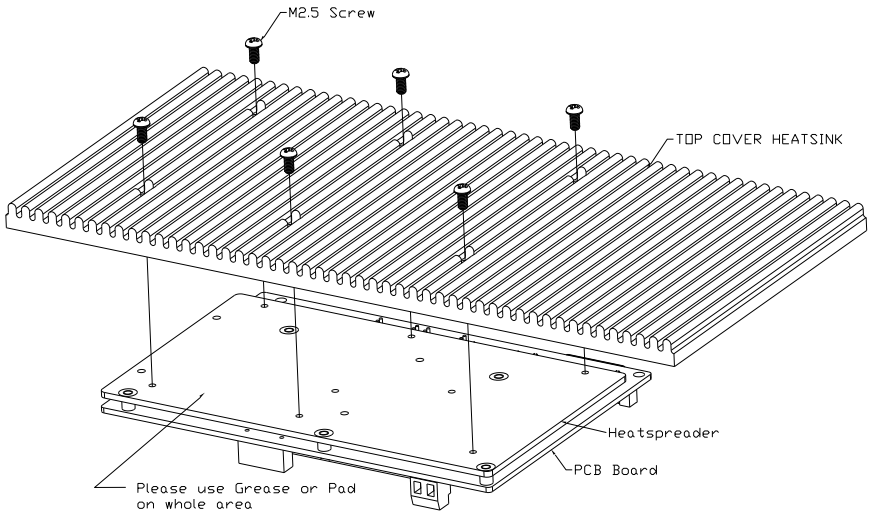

Chapter 3

AMI BIOS Setup

3.1 System Test and Initialization

The system uses certain routines to perform testing and initialization during the boot up sequence. If an error, fatal or non-fatal, is encountered, the system will output a few short beeps or an error message. The board can usually continue the boot up sequence with non-fatal errors.

The system configuration verification routines check the current system configuration against the values stored in the CMOS memory. If they do not match, an error message will be output, and the BIOS setup program will need to be run to set the configuration information in memory.

There are three situations in which the CMOS settings will need to be set or changed:

- Starting the system for the first time
- The system hardware has been changed
- The CMOS memory has lost power and the configuration information is erased

The system's CMOS memory uses a backup battery for data retention. The battery must be replaced when it runs down.

3.2 AMI BIOS Setup

The AMI BIOS ROM has a pre-installed Setup program that allows users to modify basic system configurations, which is stored in the battery-backed CMOS RAM and BIOS NVRAM so that the information is retained when the power is turned off.

To enter BIOS Setup, press or <F2> immediately while your computer is powering up.

The function for each interface can be found below.

Main – Date and time can be set here. Press <Tab> to switch between date elements

Advanced – System hardware configurations and settings

Chipset – For host bridge parameters

Security – The setup administrator password can be set here

Boot – Enable/ Disable Quiet Boot option

Save & Exit – Save your changes and exit the program

3.3 Setup submenu: Main

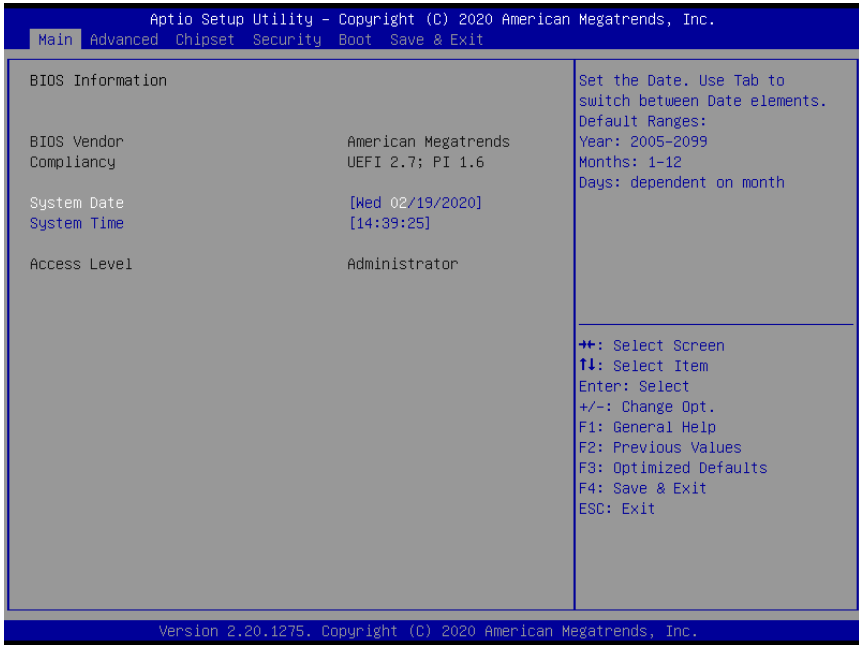

3.4 Setup submenu: Advanced

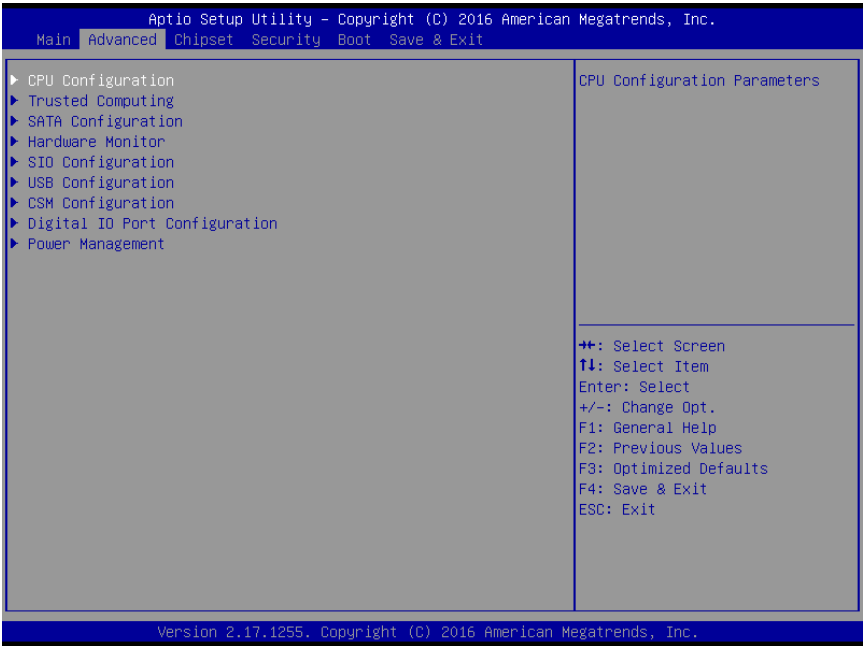

3.4.1 Advanced: CPU Management

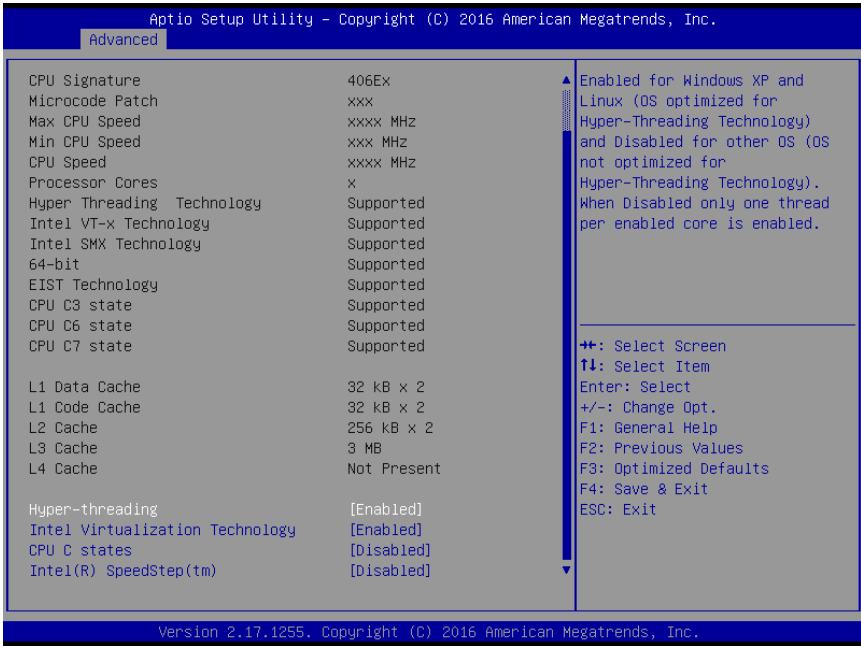

Options Summary		
Hyper-threading	Enabled	Optimal Default, Failsafe Default
	Disabled	
Enable/Disable Intel Hyper-threading (HT) feature.		
Intel Virtualization Technology	Enabled	Optimal Default, Failsafe Default
	Disabled	
When enabled, a VMM can utilize the additional hardware capabilities provide by Vanderpool Technology		
CPU C State Report	Enabled	Optimal Default, Failsafe Default
	Disabled	
Enable/Disable CPU C state report to OS		
Intel(R) SpeedStep(tm)	Enabled	Optimal Default, Failsafe Default
	Disabled	
Enable/Disable Intel SpeedStep feature.		

Options Summary

Turbo Mode	Enabled	Optimal Default, Failsafe Default
	Disabled	
Enable/Disable Turbo mode. This feature is only available when Intel SpeedStep enabled.		

3.4.2 Advanced: SATA Configuration

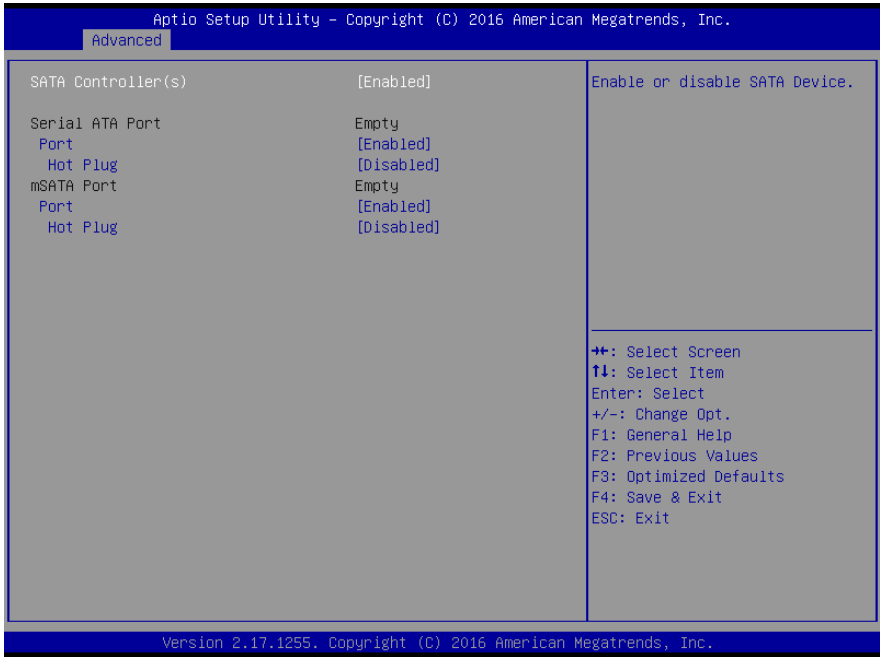

Options Summary		
SATA Speed Support	Enabled	Optimal Default, Failsafe Default
	Disabled	
Enable or disable SATA Device		
Serial ATA Port/mSATA Port	Enabled	Optimal Default, Failsafe Default
	Disabled	
Enabled/Disabled Serial ATA Port/mSATA Port		
Serial ATA Port/mSATA Port Hot Plug	Enabled	Optimal Default, Failsafe Default
	Disabled	
Designated specified port as Hot Pluggable.		

3.4.3 Advanced: USB Configuration

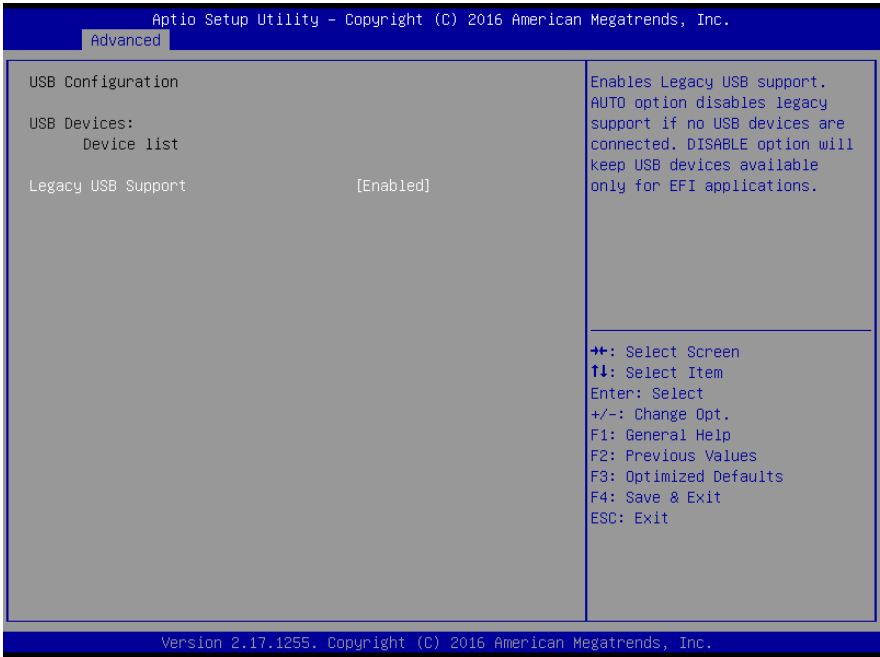

Options Summary		
Legacy USB Support	Enabled	Optimal Default, Failsafe Default
	Disabled	
	Auto	
Enables BIOS Support for Legacy USB Support. When enabled, USB can be functional in legacy environment like DOS. AUTO option disables legacy support if no USB devices are connected. DISABLE option will keep USB devices available only for EFI application.		

3.4.4 Advanced: SIO Configuration

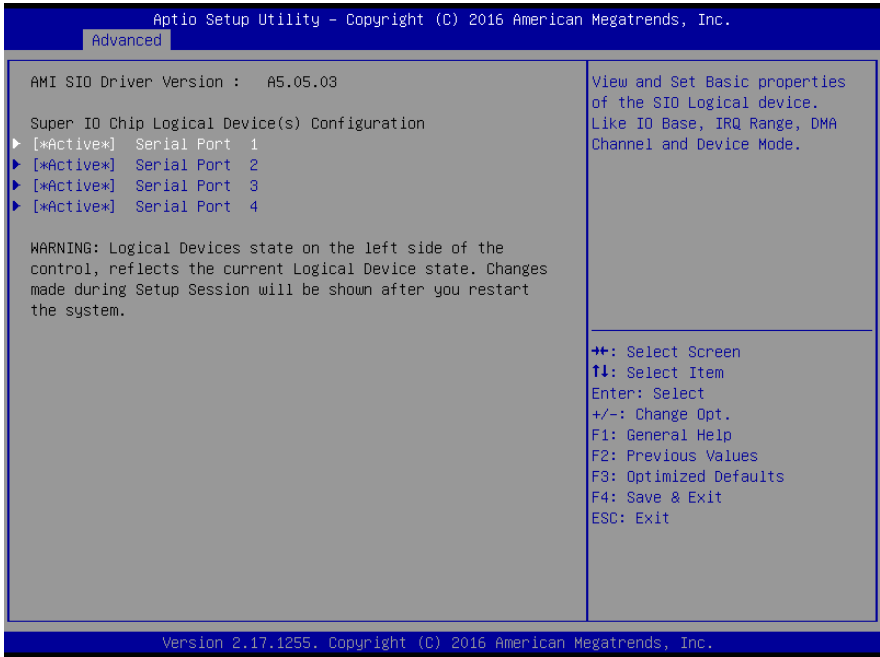

3.4.4.1 SIO Configuration: Serial Port 1-4 Configuration

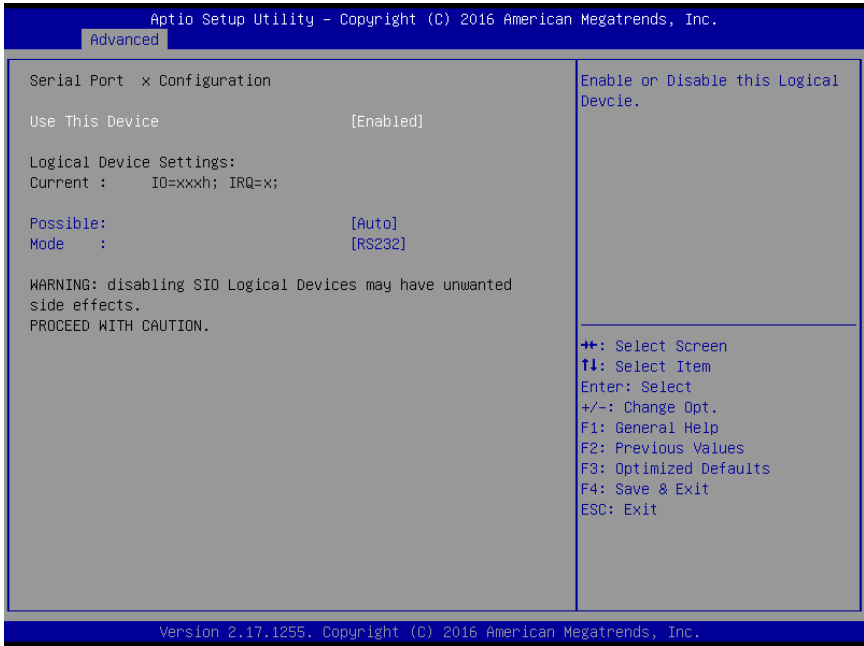

Options Summary		
Use This Device	Disabled	Optimal Default, Failsafe Default
	Enabled	
Enable/ Disable specified serial port.		
Change Settings (COM1)	Use Automatic Settings	Optimal Default, Failsafe Default
	IO=3F8h; IRQ=4;	
	IO=2F8h; IRQ=3;	
Change Settings (COM2)	Use Automatic Settings	Optimal Default, Failsafe Default
	IO=2F8h; IRQ=3;	
	IO=3F8h; IRQ=4;	
Change Settings (COM3)	Use Automatic Settings	Optimal Default, Failsafe Default
	IO=3E8h; IRQ=11;	
	IO=2E8h; IRQ=11;	
Change Settings (COM4)	Use Automatic Settings	Optimal Default, Failsafe Default
	IO=2E8h; IRQ=11;	
	IO=3E8h; IRQ=11;	

Options Summary

Select a resource setting for Super IO device.

Mode	RS232	Optimal Default, Failsafe Default
	RS422	
	RS485	

Configure COM operated as RS232, RS422 or RS485. Only COM3 and COM4 support this function.

3.4.5 Advanced: Hardware Monitor

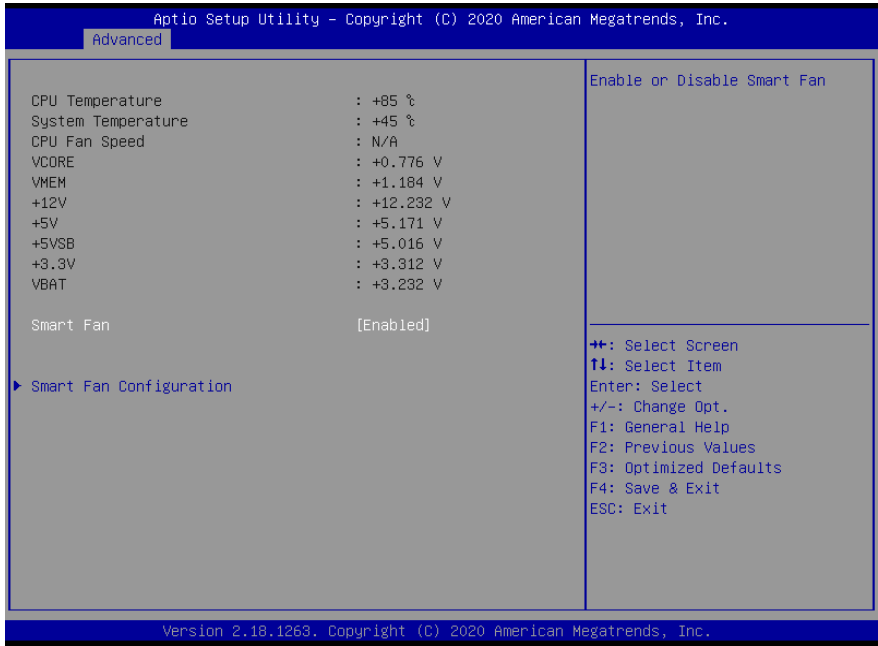

Options Summary		
Smart Fan	Enabled	Optimal Default, Failsafe Default
	Disabled	
Enable or Disable Smart Fan.		

3.4.5.1 Hardware Monitor: Smart Fan Configuration

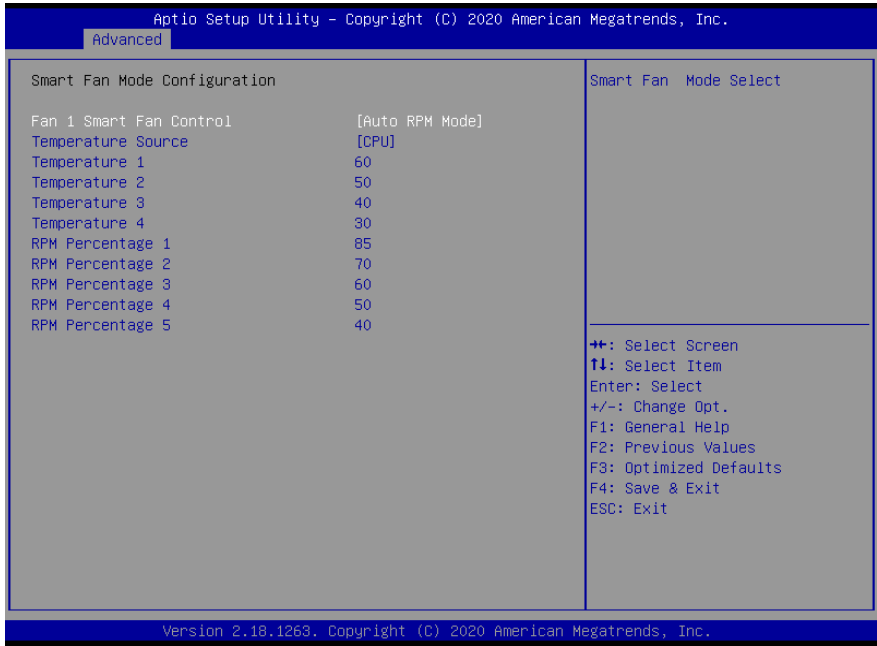

Options Summary – Auto RPM Mode		
Fan Mode	Manual RPM Mode	
	Auto RPM Mode	Optimal Default, Failsafe Default
Smart Fan Mode Select		
Temperature Source	CPU	Optimal Default, Failsafe Default
Select the monitored temperature source for this fan.		
PM Percentage	Auto fan speed control. Fan speed will follow different	
Temperature	temperature by different RPM 1-100	

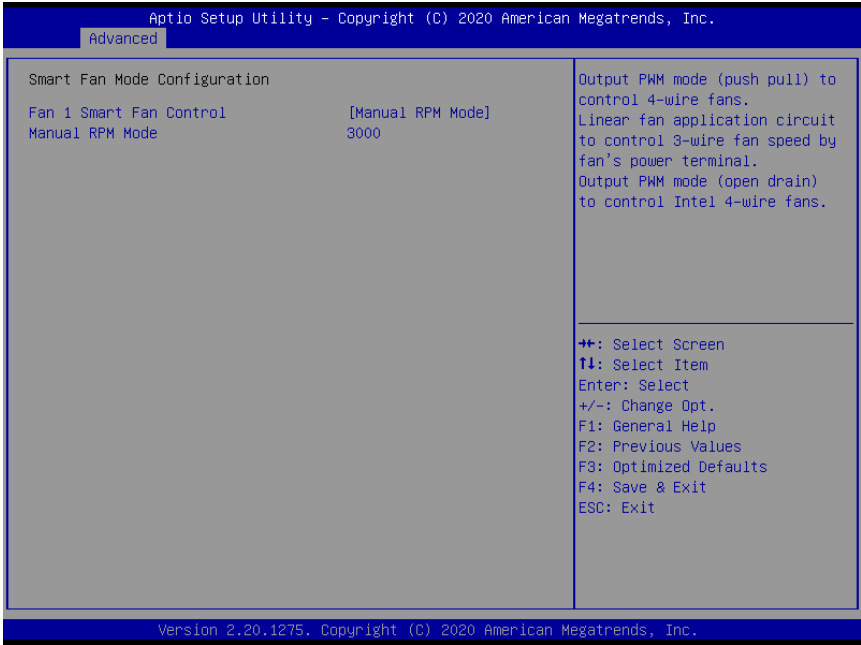

Options Summary – Manual RPM Mode

Manual RPM mode	3000	Optimal Default, Failsafe Default
RPM value		

3.4.6 Advanced: CSM Configuration

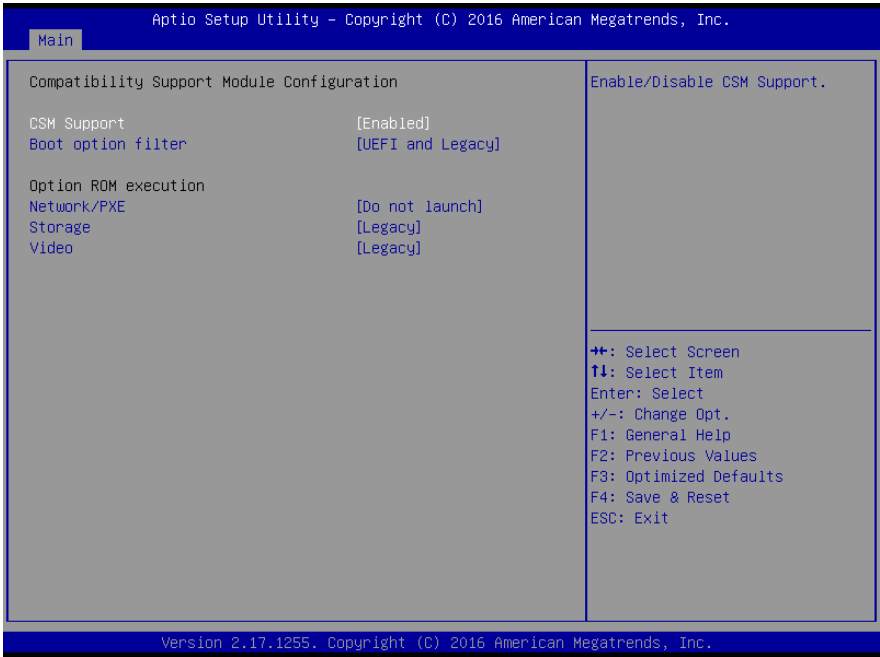

Options Summary		
CSM Support	Enabled	Optimal Default, Failsafe Default
	Disabled	
Enable/Disable for CSM Support		
Boot option filter	UEFI and Legacy	Optimal Default, Failsafe Default
	Legacy only	
	UEFI only	
This option controls Legacy/UEFI boot option priority		
Network/PXE	Do not launch	Optimal Default, Failsafe Default
	UEFI	
	Legacy	
Controls the execution of UEFI and Legacy PXE OpROM		
Storage	Do not launch	Optimal Default, Failsafe Default
	UEFI	
	Legacy	
Controls the execution of UEFI and Legacy Storage OpROM		

Options Summary		
Video	Do not launch	Optimal Default, Failsafe Default
	UEFI	
	Legacy	
Controls the execution of UEFI and Legacy Video OpROM		

3.4.7 Advanced: Power Management

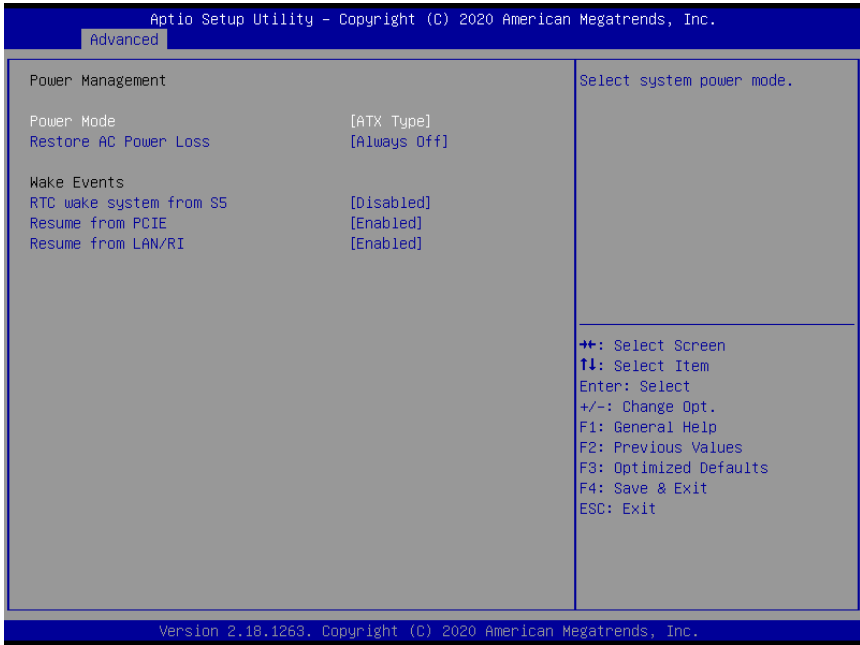

Options Summary		
Power Mode	ATX Type	Optimal Default, Failsafe Default
	AT Type	
Select system power mode		
Restore AC Power Loss	Power Off	Optimal Default, Failsafe Default
	Power on	
	Late State	
Select AC power state when power is re-applied after a power failure		
RTC wake system from S5	Disabled	Optimal Default, Failsafe Default
	Fixed Time	
	Dynamic Time	
Enable system to wake from S5 using RTC alarm.		
Wake up day	0-31	
Select 0 for daily system wake up 1-31 for which day of the month that you would like the system to wake up		

Options Summary		
Wake up hour	0-23	
Wake up minute	0-59	
Wake up second	0-59	
Wake up minute increase	1-5	
Resume from PCIE	Enabled	Optimal Default, Failsafe Default
	Disabled	
Enabled or disabled resume from PCIE WAKE#.		
Resume from LAN/RI	Enabled	Optimal Default, Failsafe Default
	Disabled	
Enabled or disabled resume from LAN/RI		

3.4.8 Advanced: Digital IO Port Configuration

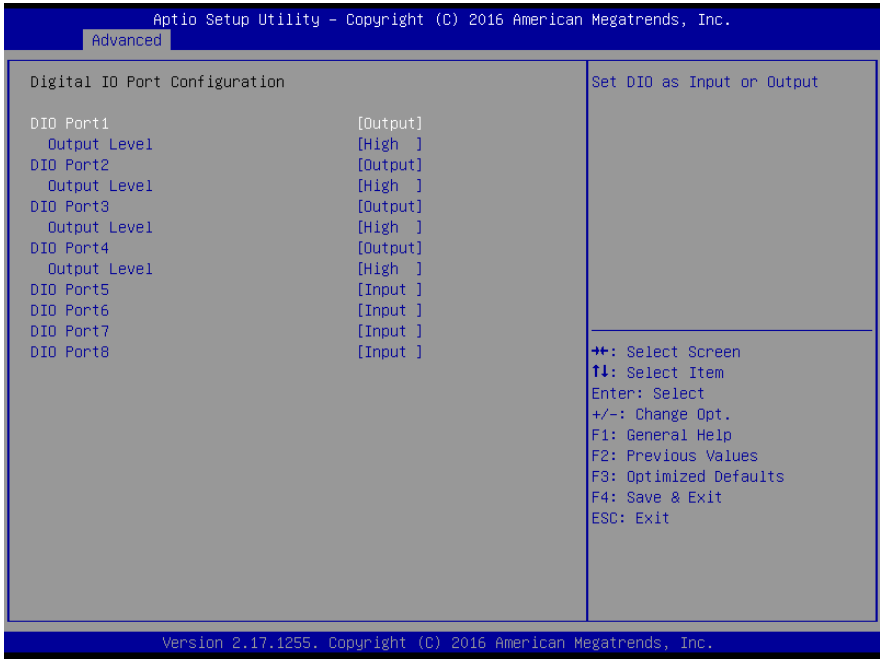

Options Summary		
DIO Port1/2/3/4	Input	Optimal Default, Failsafe Default
	Output	
Set DIO Port1/2/3/4 as Input or Output		
DIO Port5/6/7/8	Input	Optimal Default, Failsafe Default
	Output	
Set GPIO3/GPIO4 as Input or Output		
Output Level	Hi	Optimal Default, Failsafe Default
	Low	
Set GPIO Level when used as Output		

3.5 Setup submenu: Chipset

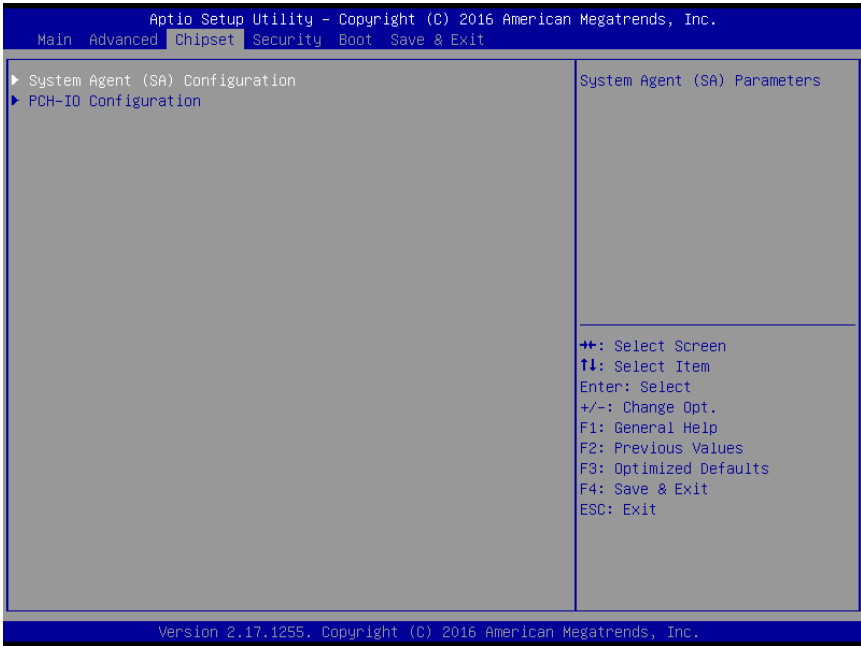

3.5.1 Chipset: System Agent (SA) Configuration

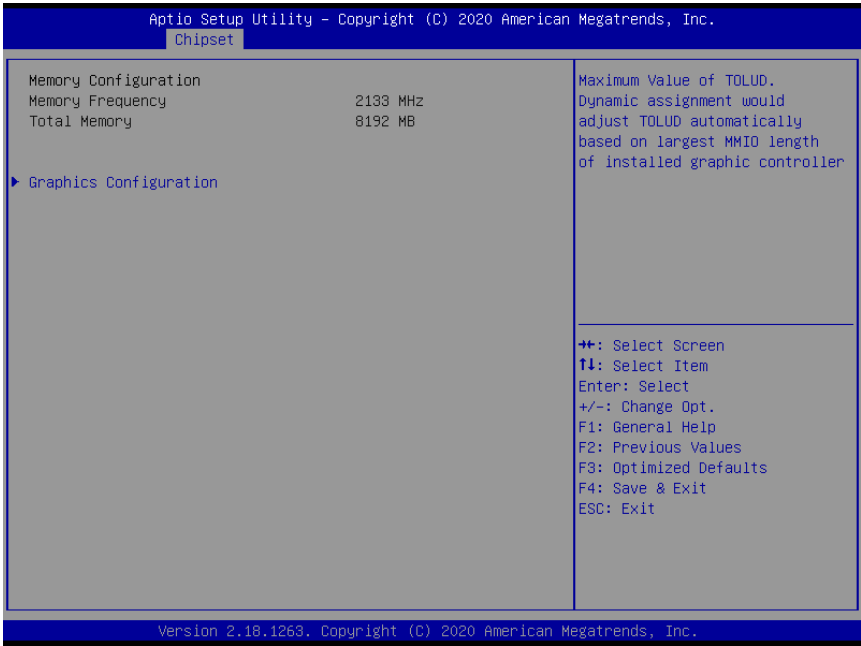

3.5.1.1 System Agent (SA) Configuration: Graphics Configuration

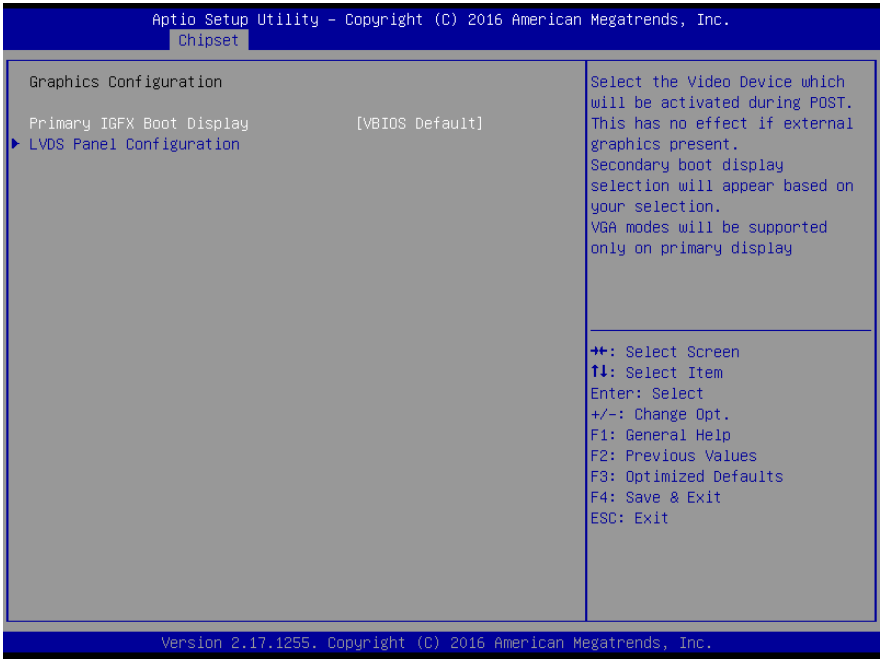

Options Summary		
Primary IGFX Boot Display	VBIOS Default	Optimal Default, Failsafe Default
	HDMI	
	CRT	
	LVDS	
Select Primary boot display device		
LVDS Panel Configuration		
Config LVDS panel parameters.		

3.5.1.2 Graphics Configuration: LVDS Panel Configuration

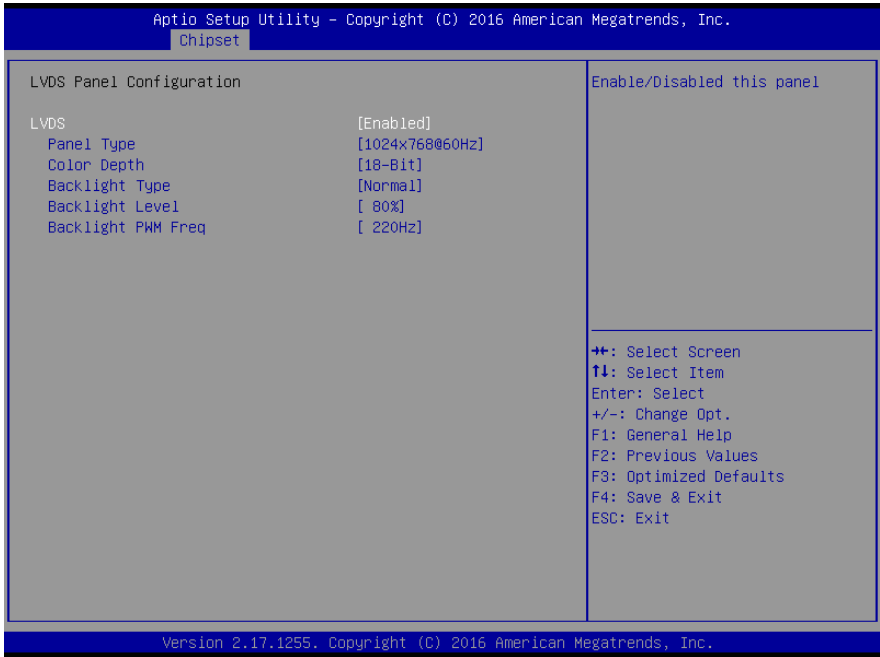

Options Summary		
LVDS	Disabled	Optimal Default, Failsafe Default
	Enabled	
Enable or Disable LVDS interface		
Panel Type	640x480@60Hz	
	800x480@60Hz	
	800x600@60Hz	
	1024x600@60Hz	
	1024x768@60Hz	Optimal Default, Failsafe Default
	1280x768@60Hz	
	1280x800@60Hz	
	1280x1024@60Hz	
	1366x768@60Hz	
	1440x900@60Hz	
1600x1200@60Hz		

Options Summary		
	1920x1080@60Hz	
	1920x1200@60Hz	
Select panel resolution.		
Color Depth	18-Bit	Optimal Default, Failsafe Default
	24-Bit	
	36-Bit	
	48-Bit	
Select color depth of the panel		
Backlight Type	Inverted	Optimal Default, Failsafe Default
	Normal	
Select Backlight control type. Inverted: Brightest for low PWM duty cycle and low voltage. Normal: Brightest for high PWM duty cycle and high voltage.		
Backlight Level	100%	
	90%	
	80%	Optimal Default, Failsafe Default
	70%	
	60%	
	50%	
	40%	
	30%	
	20%	
	10%	
0%		
Select Backlight Level		
Backlight PWM Freq	100Hz	
	200Hz	
	220Hz	Optimal Default, Failsafe Default
	500Hz	
	1KHz	
	2.2KHz	
	6.5KHz	
Select PWM frequency of backlight control signal.		

3.5.2 Chipset: PCH-IO Configuration

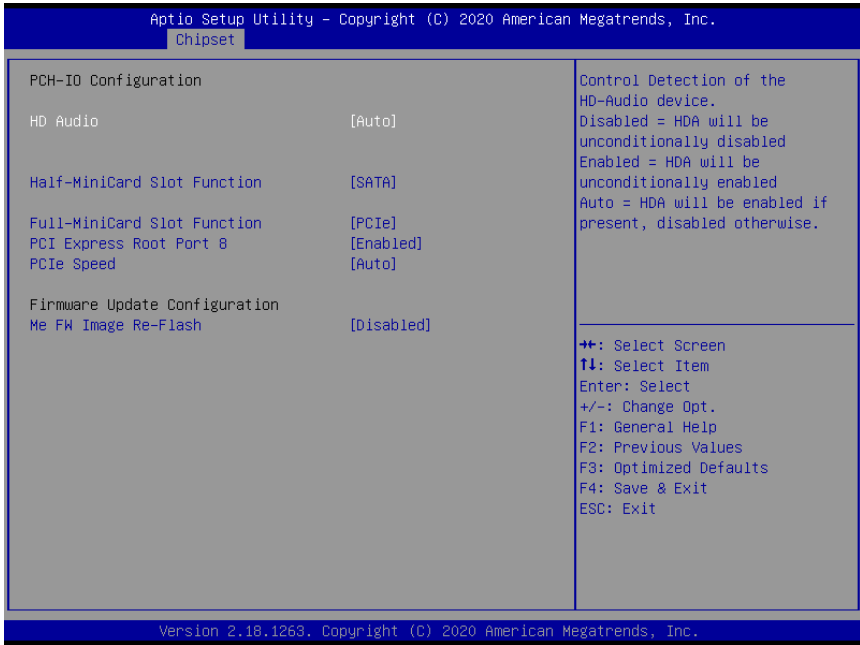

Options Summary		
HD Audio	Disabled	
	Enabled	
	Auto	Optimal Default, Failsafe Default
Enable/ Disable HD Audio		
Half-MiniCard Slot Function	SATA	Optimal Default, Failsafe Default
	PCIe	
Select function enabled for Half size MiniCard Slot		
Full-MiniCard Slot Function	SATA	
	PCIe	Optimal Default, Failsafe Default
Select function enabled for Full size MiniCard Slot		
PCI Express Root 8	Disabled	
	Enabled	Optimal Default, Failsafe Default
Enable/ Disable Full size MiniCard Slot PCIe		

Options Summary		
PCIe Speed	Auto	Optimal Default, Failsafe Default
	Gen1	
	Gen2	
	Gen3	
PCI Express Root 8 Gen Speed		
Me FW Image Re-Flash	Disabled	Optimal Default, Failsafe Default
	Enabled	
Enable/ Disable Me FW Image Re-Flash function		

3.6 Setup submenu: Security

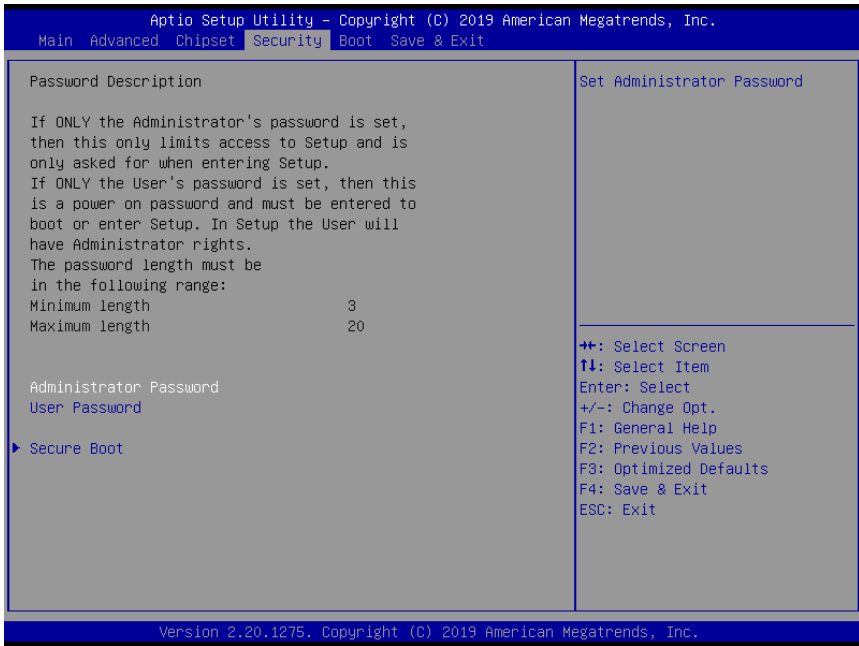

Change User/Administrator Password

You can set an Administrator Password or User Password. An Administrator Password must be set before you can set a User Password. The password will be required during boot up, or when the user enters the Setup utility. A User Password does not provide access to many of the features in the Setup utility.

Select the password you wish to set, and press Enter. In the dialog box, enter your password (must be between 3 and 20 letters or numbers). Press Enter and retype your password to confirm. Press Enter again to set the password.

Removing the Password

Select the password you want to remove and enter the current password. At the next dialog box press Enter to disable password protection.

3.6.1 Secure Boot

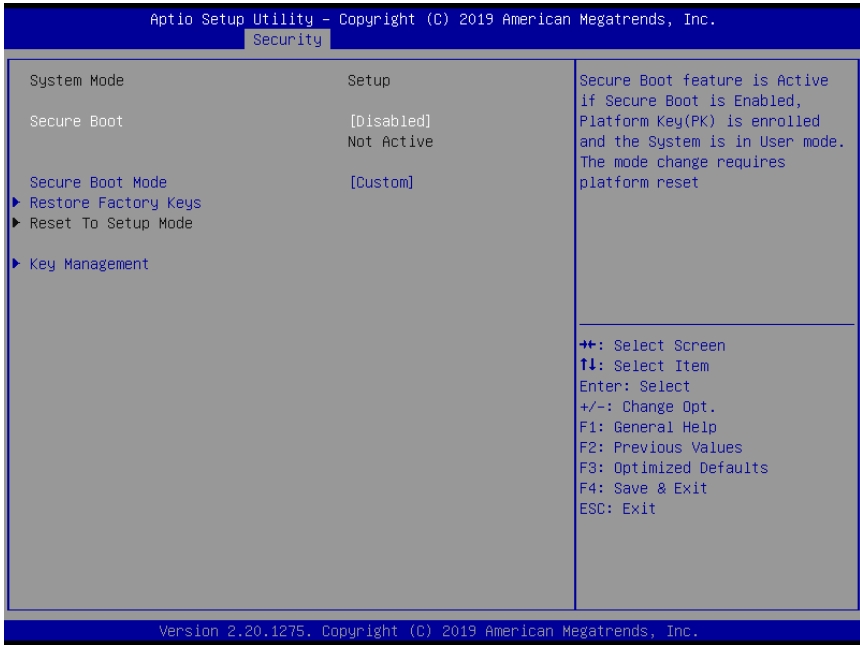

Options Summary		
Secure Boot	Disabled	Optimal Default, Failsafe Default
	Enabled	
Secure Boot feature is Active if Secure Boot is Enabled, Platform Key (PK) is enrolled and the System is in User mode. The mode change requires platform reset		
Secure Boot Mode	Custom	Optimal Default, Failsafe Default
	Standard	
Secure Boot mode options: Standard or Custom. In Custom mode, Secure Boot Policy variables can be configured by a physically present user without full authentication		
Restore Factory Keys		
Force System to User Mode. Install factory default Secure Boot key databases		
Reset To Setup Mode		
Delete all Secure Boot key databases from NVRAM		

3.6.1.1 Key Management

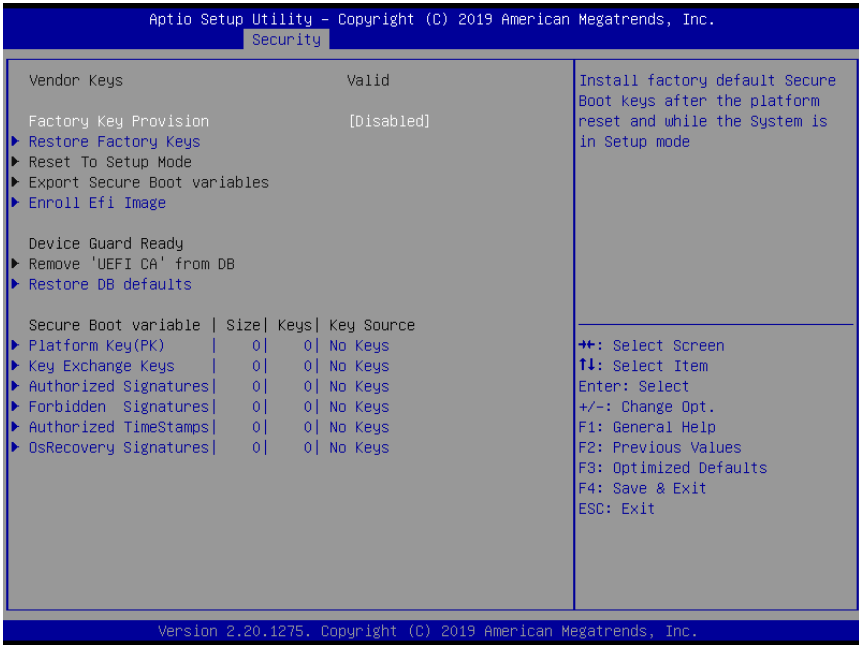

Options Summary		
Factory Key Provision	Disabled	Optimal Default, Failsafe Default
	Enabled	
Secure Boot feature is Active if Secure Boot is Enabled, Platform Key (PK) is enrolled and the System is in User mode. The mode change requires platform reset		
Restore Factory Keys		
Force System to User Mode. Install factory default Secure Boot key databases		
Reset To Setup Mode		
Delete all Secure Boot key databases from NVRAM		
Export Secure Boot variables		
Copy NVRAM content of Secure Boot variables to files in a root folder on a file system device		
Enroll Efi Image		
Allow the image to run in Secure Boot mode. Enroll SHA256 Hash certificate of a PE image into Authorized Signature Database (db)		

Options Summary		
Remove 'UEFI CA' from DB		
Device Guard ready system must not list 'Microsoft UEFI CA' Certificate in Authorized Signature database (db)		
Restore DB defaults		
Restore DB variable to factory defaults		
Platform Key (PK)	Details	
	Export	
	Update	
	Delete	
Key Exchange Keys	Details	
	Export	
	Update	
	Delete	
Authorized Signatures	Details	
	Export	
	Update	
	Delete	
Forbidden Signatures	Details	
	Export	
	Update	
	Delete	
Authorized TimeStamps	Update	
	Append	
OsRecovery Signatures	Update	
	Append	
Enroll Factory Defaults or load certificates from a file:		
1.Public Key Certificate:		
a)EFI_SIGNATURE_LIST		
b)EFI_CERT_X509 (DER)		
c)EFI_CERT_RSA2048 (bin)		
d)EFI_CERT_SHAXXX		
2.Authenticated UEFI Variable		
3.EFI PE/COFF Image(SHA256)		
Key Source: Factory,External,Mixed		

3.7 Setup submenu: Boot

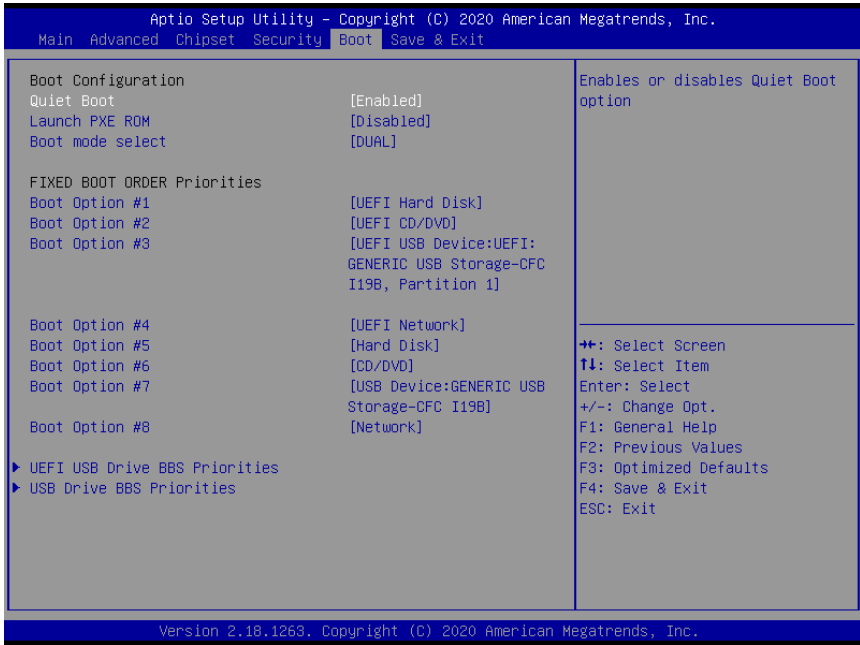

Options Summary		
Quiet Boot	Disabled	
	Enabled	Optimal Default, Failsafe Default
Enable or Disable showing boot logo.		
Lunch PXE ROM	Disabled	Optimal Default, Failsafe Default
	Enabled	
Controls the execution of UEFI and Legacy Network OpROM		
Boot mode select	LEGACY	
	UEFI	
	DUAL	Optimal Default, Failsafe Default
Select boot mode		

3.7.1 Boot: BBS Priorities

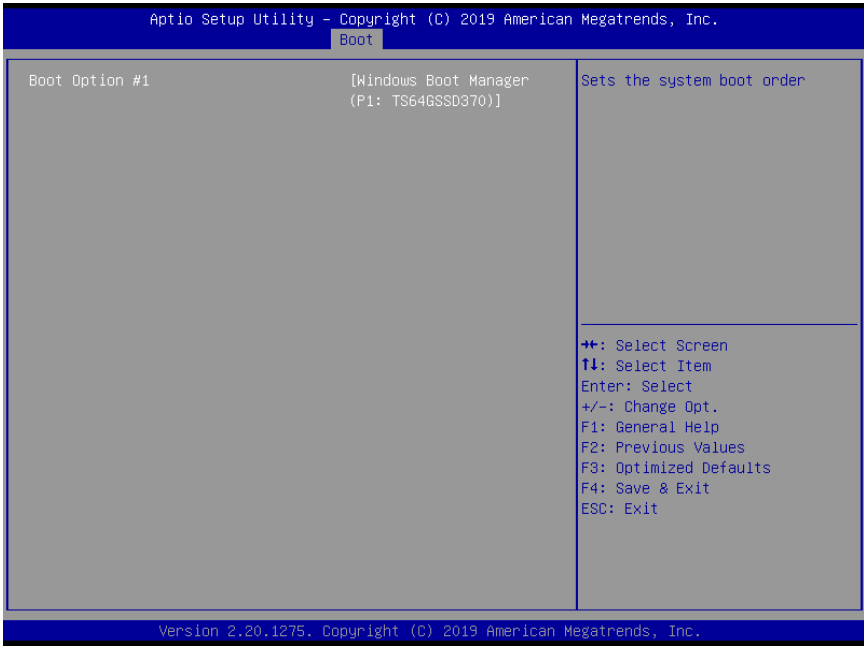

3.8 Setup submenu: Save & Exit

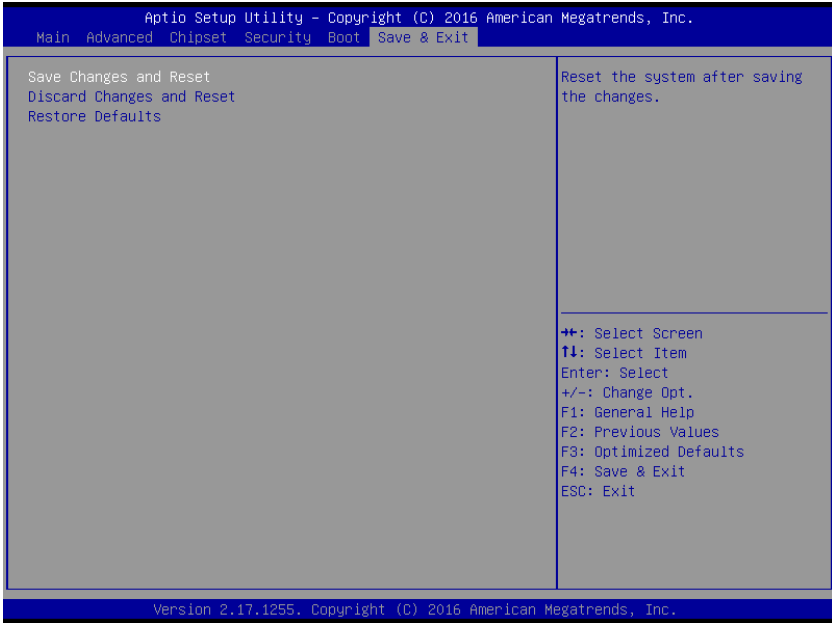

Chapter 4

Drivers Installation

4.1 Driver Download/Installation

Drivers for the GENE-SKU6 Rev. B can be downloaded from the product page on the AAEON website by following this link:

<https://www.aaeon.com/en/p/embedded-single-board-computers-gene-sku6-rev-b>

Download the driver(s) you need and follow the steps below to install them.

Step 1 – Install Chipset Drivers

1. Open the **Step1 - Chipset** folder followed by **SetupChipset.exe**
2. Follow the instructions
3. Drivers will be installed automatically

Step 2 – Install Graphics Drivers

1. Open the **Step2 - VGA** folder and select your OS
2. Open the **Setup.exe** file in the folder
3. Follow the instructions
4. Drivers will be installed automatically

Step 3 – Install LAN Drivers

1. Click on the **Step3 - LAN** folder and select your OS
2. Open the **.exe** file in the folder
3. Follow the instructions
4. Drivers will be installed automatically

Step 4 – Install Audio Drivers

1. Open the **Step4 - Audio** folder and select your OS
2. Open the **.exe** file in the folder
3. Follow the instructions
4. Drivers will be installed automatically

Step 5 – Install USB 3.0 Driver (Windows 7 only)

1. Open the **Step5 - USB3.0** folder followed by **Setup.exe**
2. Follow the instructions
3. Drivers will be installed automatically

Step 6 – Install TPM 2.0 Driver (Windows 7 only)

1. Open the **Step6 TPM 2.0** folder followed by the **.msu** file
2. Follow the instructions
3. Drivers will be installed automatically

Step 7 – Install Touch Driver

1. Open the **Step7 - PenMount Touch 6000** folder followed by **Setup.exe**
2. Follow the instructions
3. Drivers will be installed automatically

Step 8 – Install Serial Port Drivers

For Windows 7:

1. Change User Account Control settings to **Never notify**

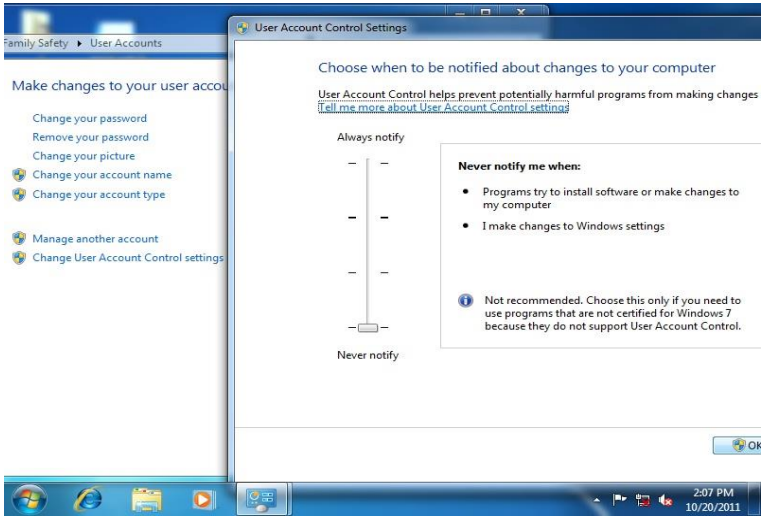

2. Reboot and log in as administrator

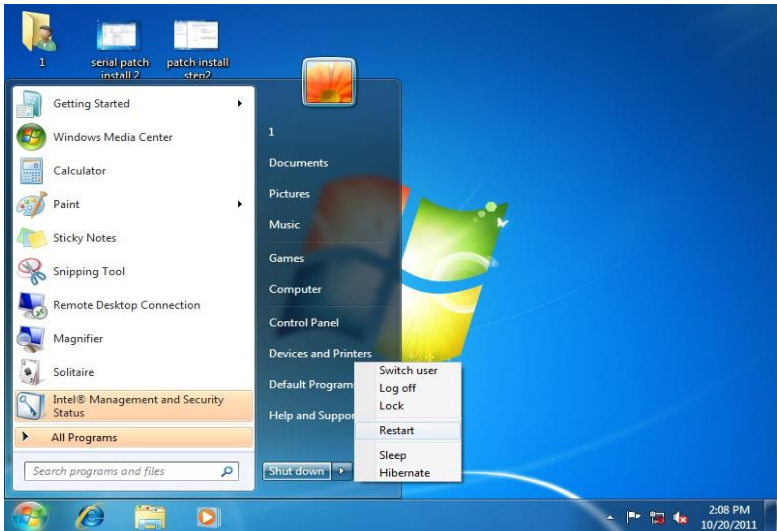

3. Run patch.bat as administrator

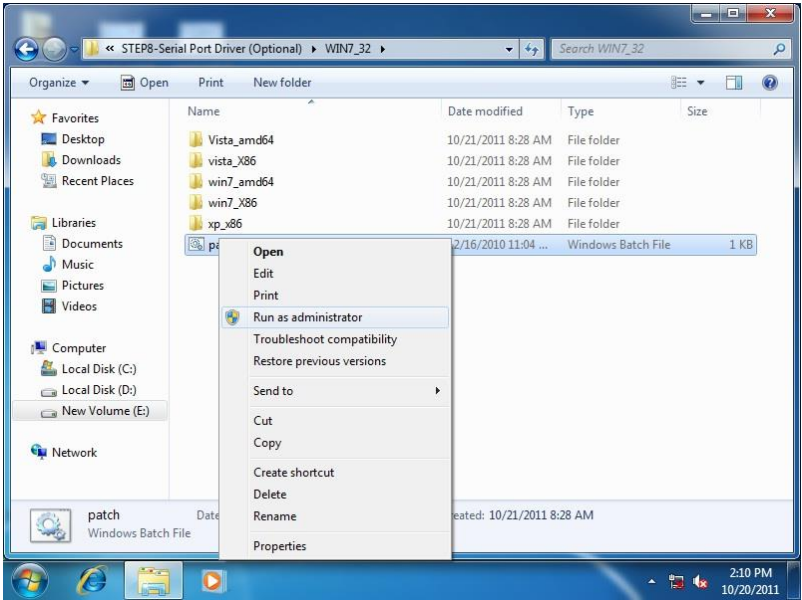

For Windows 8/10:

1. Click on the **Step8 - Serial Port Driver (Optional)** folder and select your OS
2. Open the **setup.exe** file in the folder
3. Follow the instructions
4. Drivers will be installed automatically

4.2 Note on EHCI

With the EHCI controller no longer available on the 6th Generation Intel® Core™ platforms, it is recommended to install Windows 7 through a SATA bus, e.g. SATA DVD-ROM, or patch the xHCI driver onto an installation media for Windows 7. More information can be found in the links below:

[Windows 7 USB 3.0 Creator Utility](#)

[Read me](#)

For input devices, please use an add-on standard EHCI controller expansion card, such as PCIe to USB 2.0 conversion card.

Appendix A

I/O Information

A.1 I/O Address Map





























Note: There are no PS/2 ports on the GENE-SKU6 Rev. B, hence the exclamation marks.

Input/output (I/O)	
[0000000000000000 - 0000000000000CF7]	PCI Express Root Complex
[0000000000000020 - 000000000000021]	Programmable interrupt controller
[0000000000000024 - 000000000000025]	Programmable interrupt controller
[0000000000000028 - 000000000000029]	Programmable interrupt controller
[000000000000002C - 00000000000002D]	Programmable interrupt controller
[000000000000002E - 00000000000002F]	Motherboard resources
[0000000000000030 - 000000000000031]	Programmable interrupt controller
[0000000000000034 - 000000000000035]	Programmable interrupt controller
[0000000000000038 - 000000000000039]	Programmable interrupt controller
[000000000000003C - 00000000000003D]	Programmable interrupt controller
[0000000000000040 - 000000000000043]	System timer
[000000000000004E - 00000000000004F]	Motherboard resources
[0000000000000050 - 000000000000053]	System timer
[0000000000000060 - 000000000000060]	Standard PS/2 Keyboard
[0000000000000061 - 000000000000061]	Motherboard resources
[0000000000000063 - 000000000000063]	Motherboard resources
[0000000000000064 - 000000000000064]	Standard PS/2 Keyboard
[0000000000000065 - 000000000000065]	Motherboard resources
[0000000000000067 - 000000000000067]	Motherboard resources
[0000000000000070 - 000000000000070]	Motherboard resources
[0000000000000070 - 000000000000077]	System CMOS/real time clock
[0000000000000080 - 000000000000080]	Motherboard resources
[0000000000000092 - 000000000000092]	Motherboard resources
[00000000000000A0 - 0000000000000A1]	Programmable interrupt controller
[00000000000000A4 - 0000000000000A5]	Programmable interrupt controller
[00000000000000A8 - 0000000000000A9]	Programmable interrupt controller
[00000000000000AC - 0000000000000AD]	Programmable interrupt controller
[00000000000000B0 - 0000000000000B1]	Programmable interrupt controller
[00000000000000B2 - 0000000000000B3]	Motherboard resources
[00000000000000B4 - 0000000000000B5]	Programmable interrupt controller
[00000000000000B8 - 0000000000000B9]	Programmable interrupt controller
[00000000000000BC - 0000000000000BD]	Programmable interrupt controller
[00000000000002E8 - 00000000000002EF]	Communications Port (COM4)
[00000000000002F8 - 00000000000002FF]	Communications Port (COM2)
[00000000000003B0 - 00000000000003BB]	Intel(R) HD Graphics 520
[00000000000003C0 - 00000000000003DF]	Intel(R) HD Graphics 520
[00000000000003E8 - 00000000000003EF]	Communications Port (COM3)
[00000000000003F8 - 00000000000003FF]	Communications Port (COM1)
[00000000000004D0 - 00000000000004D1]	Programmable interrupt controller
[0000000000000680 - 000000000000069F]	Motherboard resources
[0000000000000A00 - 0000000000000A0F]	Motherboard resources
[0000000000000A10 - 0000000000000A1F]	Motherboard resources
[0000000000000A20 - 0000000000000A2F]	Motherboard resources
[0000000000000D00 - 000000000000FFFF]	PCI Express Root Complex
[000000000000164E - 000000000000164F]	Motherboard resources
[0000000000001800 - 00000000000018FE]	Motherboard resources
[0000000000001854 - 0000000000001857]	Motherboard resources
[000000000000D000 - 000000000000DFFF]	Intel(R) 100 Series Chipset Family PCI Express Root Port #4 - 9D13
[000000000000E000 - 000000000000EFFF]	Intel(R) 100 Series Chipset Family PCI Express Root Port #3 - 9D12
[000000000000E000 - 000000000000EFFF]	Intel(R) 100 Series/C230 Series Chipset Family PCI Express Root Port #6 - A115
[000000000000F000 - 000000000000F03F]	Intel(R) HD Graphics 520
[000000000000F040 - 000000000000F05F]	Intel(R) 100 Series Chipset Family SMBUS - 9D23
[000000000000F060 - 000000000000F07F]	Standard SATA AHCI Controller
[000000000000F080 - 000000000000F083]	Standard SATA AHCI Controller
[000000000000F090 - 000000000000F097]	Standard SATA AHCI Controller
[000000000000FF00 - 000000000000FFFE]	Motherboard resources
[000000000000FFFF - 000000000000FFFF]	Motherboard resources
[000000000000FFFF - 000000000000FFFF]	Motherboard resources
[000000000000FFFF - 000000000000FFFF]	Motherboard resources

A.2 Memory Address Map

Memory	
[0000000000A0000 - 0000000000BFFFF]	Intel(R) HD Graphics 520
[0000000000A0000 - 0000000000BFFFF]	PCI Express Root Complex
[0000000090000000 - 00000000DFFFFFFF]	PCI Express Root Complex
[00000000C0000000 - 00000000CFFFFFFF]	Intel(R) HD Graphics 520
[00000000DE000000 - 00000000DEFFFFFF]	Intel(R) HD Graphics 520
[00000000DF000000 - 00000000DF01FFFF]	Intel(R) I210 Gigabit Network Connection #2
[00000000DF000000 - 00000000DF0FFFFF]	Intel(R) 100 Series Chipset Family PCI Express Root Port #4 - 9D13
[00000000DF020000 - 00000000DF023FFF]	Intel(R) I210 Gigabit Network Connection #2
[00000000DF100000 - 00000000DF11FFFF]	Intel(R) I210 Gigabit Network Connection
[00000000DF100000 - 00000000DF1FFFFF]	Intel(R) 100 Series Chipset Family PCI Express Root Port #3 - 9D12
[00000000DF120000 - 00000000DF123FFF]	Intel(R) I210 Gigabit Network Connection
[00000000DF200000 - 00000000DF20FFFF]	High Definition Audio Controller
[00000000DF210000 - 00000000DF21FFFF]	Intel(R) USB 3.0 Host Controller Adaptation Driver
[00000000DF220000 - 00000000DF223FFF]	High Definition Audio Controller
[00000000DF224000 - 00000000DF227FFF]	Intel(R) 100 Series Chipset Family PMC - 9D21
[00000000DF228000 - 00000000DF229FFF]	Standard SATA AHCI Controller
[00000000DF22A000 - 00000000DF22A0FF]	Intel(R) 100 Series Chipset Family SMBUS - 9D23
[00000000DF22B000 - 00000000DF22B7FF]	Standard SATA AHCI Controller
[00000000DF22C000 - 00000000DF22C0FF]	Standard SATA AHCI Controller
[00000000DF22E000 - 00000000DF22EFFF]	Intel(R) 100 Series Chipset Family Thermal subsystem - 9D31
[00000000DFFE0000 - 00000000DFFFFFFF]	Motherboard resources
[00000000E0000000 - 00000000EFFFFFFF]	Motherboard resources
[00000000FD000000 - 00000000FDABFFFF]	Motherboard resources
[00000000FD000000 - 00000000FE7FFFFF]	PCI Express Root Complex
[00000000FDAC0000 - 00000000FDACFFFF]	Motherboard resources
[00000000FDAD0000 - 00000000FDADFFFF]	Motherboard resources
[00000000FDAE0000 - 00000000FDAEFFFF]	Motherboard resources
[00000000FDAF0000 - 00000000FDAFFFFF]	Motherboard resources
[00000000FDB00000 - 00000000FDBFFFFF]	Motherboard resources
[00000000FE000000 - 00000000FE01FFFF]	Motherboard resources
[00000000FE028000 - 00000000FE028FFF]	Motherboard resources
[00000000FE029000 - 00000000FE029FFF]	Motherboard resources
[00000000FE036000 - 00000000FE03BFFF]	Motherboard resources
[00000000FE03D000 - 00000000FE03FFFF]	Motherboard resources
[00000000FE40F000 - 00000000FE40FFFF]	Intel(R) Management Engine Interface
[00000000FE410000 - 00000000FE7FFFFF]	Motherboard resources
[00000000FED00000 - 00000000FED003FF]	High precision event timer
[00000000FED10000 - 00000000FED17FFF]	Motherboard resources
[00000000FED18000 - 00000000FED18FFF]	Motherboard resources
[00000000FED19000 - 00000000FED19FFF]	Motherboard resources
[00000000FED20000 - 00000000FED3FFFF]	Motherboard resources
[00000000FED40000 - 00000000FED44FFF]	Trusted Platform Module 2.0
[00000000FED45000 - 00000000FED8FFFF]	Motherboard resources
[00000000FED90000 - 00000000FED93FFF]	Motherboard resources
[00000000FEE00000 - 00000000FEEFFFFFFF]	Motherboard resources
[00000000FF000000 - 00000000FFFFFFF]	Intel(R) 82802 Firmware Hub Device
[00000000FF000000 - 00000000FFFFFFF]	Motherboard resources

A.3 IRQ Mapping Chart

▲		Interrupt request (IRQ)	
		(ISA) 0x00000000 (00)	System timer
		(ISA) 0x00000003 (03)	Communications Port (COM2)
		(ISA) 0x00000004 (04)	Communications Port (COM1)
		(ISA) 0x00000008 (08)	System CMOS/real time clock
		(ISA) 0x0000000B (11)	Communications Port (COM3)
		(ISA) 0x0000000B (11)	Communications Port (COM4)
		(ISA) 0x0000000E (14)	Motherboard resources
		(PCI) 0x0000000B (11)	Intel(R) 100 Series Chipset Family SMBUS - 9D23
		(PCI) 0x00000010 (16)	High Definition Audio Controller
		(PCI) 0x00000010 (16)	Standard SATA AHCI Controller
		(PCI) 0xFFFFFDED (-19)	Intel(R) I210 Gigabit Network Connection #2
		(PCI) 0xFFFFFDEE (-18)	Intel(R) I210 Gigabit Network Connection #2
		(PCI) 0xFFFFFDEF (-17)	Intel(R) I210 Gigabit Network Connection #2
		(PCI) 0xFFFFFDF0 (-16)	Intel(R) I210 Gigabit Network Connection #2
		(PCI) 0xFFFFFDF1 (-15)	Intel(R) I210 Gigabit Network Connection #2
		(PCI) 0xFFFFFDF2 (-14)	Intel(R) I210 Gigabit Network Connection #2
		(PCI) 0xFFFFFDF3 (-13)	Intel(R) I210 Gigabit Network Connection
		(PCI) 0xFFFFFDF4 (-12)	Intel(R) I210 Gigabit Network Connection
		(PCI) 0xFFFFFDF5 (-11)	Intel(R) I210 Gigabit Network Connection
		(PCI) 0xFFFFFDF6 (-10)	Intel(R) I210 Gigabit Network Connection
		(PCI) 0xFFFFFDF7 (-9)	Intel(R) I210 Gigabit Network Connection
		(PCI) 0xFFFFFDF8 (-8)	Intel(R) I210 Gigabit Network Connection
		(PCI) 0xFFFFFDF9 (-7)	Intel(R) Management Engine Interface
		(PCI) 0xFFFFFDFA (-6)	Intel(R) USB 3.0 Host Controller Adaptation Driver
		(PCI) 0xFFFFDFB (-5)	Intel(R) HD Graphics 520
		(PCI) 0xFFFFDFC (-4)	Intel(R) 100 Series Chipset Family PCI Express Root Port #4 - 9D13
		(PCI) 0xFFFFDFD (-3)	Intel(R) 100 Series Chipset Family PCI Express Root Port #3 - 9D12
		(PCI) 0xFFFFDFE (-2)	Intel(R) 100 Series Chipset Family PCI Express Root Port #1 - 9D10

Appendix B

Electrical Specifications for I/O Ports

B.1 Electrical Specifications for I/O Ports

I/O	Reference	Signal Name	Rate Output
LVDS Port Inverter/ Backlight Connector	CN7	+5V/+12V	+5V/1.5A or +12V/1.5A
Mini-Card Slot (Full-Sized)	CN11	+3.3VSB +1.5V	+3.3V/1.1A +1.5V/0.375A
Mini-Card Slot (Half-Sized)	CN13	+3.3VSB +1.5V	+3.3V/1.1A +1.5V/0.375A
+5V Output for SATA HDD	CN15	+5V	+5V/1A
USB 3.2 Gen 1 Port 0/ Port 1	CN18	+5VSB	+5V/1A (per channel)
USB 3.2 Gen 1 Port 2/ Port 3	CN19	+5VSB	+5V/1A (per channel)
USB 2.0 Port 7	CN20	+5VSB	+5V/0.5A (per channel)
USB 2.0 Port 8	CN21	+5VSB	+5V/0.5A (per channel)
Audio I/O Port	CN22	+5V	+5V/1A
Digital IO Port	CN24	+5V	+5V/1A
COM Port 4 RS-232/422/485	CN26	+5V/+12V	+5V/0.5A or +12V/0.5A
COM Port 2 RS-232/422/485	CN27	+5V/+12V	+5V/0.5A or +12V/0.5A
COM Port 3 RS-232/422/485	CN28	+5V/+12V	+5V/0.5A or +12V/0.5A
LPC Port	CN29	+3.3V	+3.3V/0.5A
CPU FAN	CN73	+12V	+12V/0.5A

Appendix C

Mating Connectors and Cables

C.1 Mating Connectors and Cables

Connector Label	Function	Mating Connector		Available Cable	Cable P/N
		Vendor	Model no		
CN1	External RTC Connector	Molex	51021-0200	Battery Cable	175011301C
CN7	LVDS Inverter Connector	JST	PHR-5	N/A	N/A
CN9	LAN Connector	Molex	44915-0001	N/A	N/A
CN10	LAN Connector	Molex	44915-0001	N/A	N/A
CN14	SATA Port	Molex	887505318	N/A	N/A
CN15	+5V Output for SATA HDD	JST	PHR-2	SATA power Cable	1702150155
CN20	USB 2.0 Connector	Molex	51021-0500	USB Cable	1700050207
CN21	USB 2.0 Connector	Molex	51021-0500	USB Cable	1700050207
CN22	Audio Connector	ACES	50247-012H0H0-001	Audio Cable	170X000156
CN23	Touch Screen Connector	JST	SHR-9V-S-B	N/A	N/A
CN24	Digital IO Port	Neltron	2026B-10	N/A	N/A
CN25	COM Port1 Connector	Molex	51021-0900	Serial Cable	1701090150
CN27	COM Port2 Connector	Molex	51021-0900	Serial Cable	1701090150
CN28	COM Port3 Connector	Molex	51021-0900	Serial Cable	1701090150
CN26	COM Port4 Connector	Molex	51021-0900	Serial Cable	1701090150
CN29	LPC Port	JST	SHR-12V-S-B	LPC Port Cable	1703120130

Connector Label	Function	Mating Connector		Available Cable	Cable P/N
		Vendor	Model no		
CN30	+9~36V Vin Connector	N/A	N/A	Power Cable	1702002010
CN32	SMBus connector	Catch Electronics	2418HJ-06	N/A	N/A
CN33	External +5VSB Power Input and PS_ON#	JST	PHR-3	ATX Cable	170220020B
CN70	Left speaker Connector	JST	PHR-2	N/A	N/A
CN71	Right speaker Connector	JST	PHR-2	N/A	N/A
CN72	LVDS Connector	HIROSE	DF13-30DS-1.25C	N/A	N/A
CN73	CPU Fan Connector	Molex	22-01-2045	N/A	N/A